

# **GANGTOK SMART CITY DEVELOPMENT LIMITED**



## **REQUEST FOR PROPOSAL**

**For**

**IMPROVEMENT OF PEDESTRIAN WALKWAY/ FOOTPATH (12 KM APPROX.) FROM  
BALUWAKHANI (VAJRA CINEMA HALL) TO RANIPOOL, GANGTOK, EAST SIKKIM  
INCLUDING DEFECT LIABILITY PERIOD OF ONE YEAR**

**Single-Stage, Two-Envelope**

**Bidding Procedure**

**Volume I**

**Technical Bid**

Issued on :  
Invitation for Bids No. : 01/SPV/GSCDL/2018 Dt: 26.11.2018  
RFP No. : SIK-Gan\_010-IEF1  
Employer : GSCDL, Sokaythang, Gangtok

## TABLE OF CONTENT

<b>NOTICE INVITING TENDER (NIT) NO. GSCDL/ TENDER/ IEF (I)</b> .....	<b>III</b>
<b>Instructions to Bidders</b> .....	<b>IV</b>
<b>PART I BIDDING PROCEDURES</b> .....	<b>1</b>
Section 1 - Instructions to Bidders .....	1
GENERAL.....	1
Section 2 - Bid Data Sheet .....	17
Section 3 - Evaluation and Qualification Criteria .....	22
1. Evaluation.....	22
2. Qualification.....	23
Section 4 - Bidding Forms .....	29
LETTER OF TECHNICAL BID .....	29
LETTER OF PRICE BID .....	31
BID SECURITY.....	33
TECHNICAL PROPOSAL .....	34
BIDDER'S QUALIFICATION.....	39
Section 5 - SCHEDULES- BILL OF QUANTITY .....	47
<b>PART II REQUIREMENTS</b> .....	<b>64</b>
Section 6 - WORKS REQUIREMENTS .....	64
SCOPE OF WORK: .....	64
6A Standard Specifications .....	65
6B Special Specifications:.....	66
6C Drawings (Vol III).....	67
6D Supplementary Information.....	69
<b>PART III CONDITIONS OF CONTRACT AND CONTRACT FORMS</b> .....	<b>70</b>
Section 7 - GENERAL DIRECTIONS AND CONDITIONS OF CONTRACT .....	70
A. General.....	70
B. Time Control .....	77
C. Quality Control .....	79
D. Cost Control.....	80
E. Finishing the Contract .....	85
Section 8 - Particular Conditions of Contract .....	90

PARTICULAR CONDITIONS OF CONTRACT.....90  
Appendix-1 Environmental Monitoring Plan.....115  
Appendix-2 Environmental Management Plan .....116  
Section 9 - Contract Forms..... 124  
Letter of Acceptance .....125  
Contract Agreement.....127  
Unconditional Performance Security .....129  
Advance Payment Security (Unconditional) .....130  
Unconditional Bank Guarantee in Lieu of Retention Money .....132  
Appendix 1 .....137



**GANGTOK SMART CITY DEVELOPMENT LIMITED**

**SOKAYTHANG, GANGTOK**

**SIKKIM – 737102**

**CIN – U9309090WB2017SGC223807**

Ref No. : 01/SPV/GSCDL/2018

Date: 26.11.2018

**NOTICE INVITING TENDER (NIT) NO. GSCDL/ TENDER/ IEF (I)**

**Competitive Bidding (Manual Bidding)**

For and on behalf of Gangtok Smart City Development Limited, Chief Executive Officer, invites sealed tender under single envelope two bid system (1E2B) from the eligible contractors/ construction firm enlisted with the Government.

Sl. No.	Contract Package No.	Title of work	Estimated cost (Rs.)	Bid security 2.5% of the bid value (In Rs.)	Period of completion	Cost of Bid Document (Rs.)
1	2	3	4	5	6	7
1	(SIK-Gan_010-IEF1)	Improvement of Pedestrian Walkway/ Footpath (12 km approx.) from Baluwakhani (Vajra Cinema Hall) to Ranipool, Gangtok, East Sikkim	1872.18 Lakhs	46.08 Lakhs	18 months	1,00,000.00

## Instructions to Bidders

1. For complete eligibility and qualification requirement, criteria in the Bidding document as specified should be followed. Financial instruments: Bid Security will be deposited in separate envelope mentioning the amount and the name of Bank either in the form of Bank Guarantee or Bank Draft payable at chief Executive Officer, GSCDL, Gangtok in the main envelope. Offers for partial bids will not be considered and summarily rejected as non-responsive. Summary of criteria are below vide complete instructions/ bidding process/ submission shall be available to the intended bidders on the bidding documents.
2. Interested eligible bidders may go through the bidding documents and obtain further information if any needed, form the Office of the undersigned from 18.12.2018 to 20.12.2018 between 11:00 hrs 15:00 hrs.
3. A complete set of bidding documents in the ENGLISH language, may be purchased by the interested eligible bidders on submission of bidder application to Chief Executive Officer, GSCDL, Gangtok 737101, Sikkim (India) and on payment of the non-refundable cost of bidding document as specified in Column no. 7 of above during normal office hours and all working days from 21.12.2018 10:00 hrs to 29.12.2018 12:00 hrs.
4. A Pre-bid meeting will be held on 04.01.2019 at 14:00 hrs in the Office of the undersigned to clarify the issues and queries raised on the proposed bid. Bidders may seek clarification form the Office of the undersigned on the bid on or before 14:00 hrs of 04.01.2019, if required.
5. Sealed bid in duplicate duly signed by authorised signatory must be delivered to CEO, GSCDL, Gangtok 737101, Sikkim (India) on or before 14:00 hrs of 08.01.2019. All bids must be accompanied by a Bid Security as specified in the bidding document for an amount as specified above in Column no. 5. Late bid will not be accepted by tendering authority., Technical bid will be opened at 14:30 hrs on 08.01.2019 by tendering authority for GSCDL in the presence of bidders or bidders' representatives who chose to attend the process. Successful technical bidders will be called for attending opening of the Financial bidding at the Office of the undersigned at said time And date of the intimation on the notice board of GSCDL, Sokaythang. The details of bids can also be viewed through the website of [www.qmcsikkim.in](http://www.qmcsikkim.in) and [www.smartnet.niua.org](http://www.smartnet.niua.org)
6. The purchaser/ intending bidders will be responsible for all costs/ expenses incurred in connection with the preparation or delivery of the bids and site visits.
7. GSCDL reserves the right to change or postpone above schedule, reduce the scope of work and reject any non-responsive tenders/ bids without assigning any reason thereof.

Chief Executive Officer  
Gangtok Smart City Development Limited

# **PART I BIDDING PROCEDURES**

## **Section 1 - Instructions to Bidders**

### **GENERAL**

#### **1. SCOPE OF BIDS:**

- 1.1. In connection with the Invitation for Bids indicated in the Bid Data Sheet (BDS), the Employer/GSCDL, as indicated in the BDS, issues this Bidding Document for the procurement of Works as specified in Section 6 (Employer's Requirements). The name and identification, number of the contract of the Request for Proposal (RFP) are provided in the BDS.
- 1.2. Throughout this Bidding Document:
  - (a) the term "in writing" means communicated in written form and delivered against receipt;
  - (b) except where the context requires otherwise, words indicating the singular also include the plural and words indicating the plural also include the singular; and
  - (c) "day" means calendar day.

#### **2. SOURCE OF FUND:**

- 2.1. The Borrower or Recipient (hereinafter called "GSCDL") indicated in the BDS has applied for or received financing (hereinafter called "funds") from the Smart City Mission (SCM) towards the cost of the project named in the BDS. The Borrower intends to apply a portion of the funds to eligible payments under the contract(s) for which this Bidding Document is issued.
- 2.2. Deleted

#### **3. Fraud and Corruption**

- 3.1. The Anticorruption Policy applicable in state of Sikkim requires bidders, suppliers, subcontractors and contractors under GSCDL-financed contracts, observe the highest standard of ethics during the procurement and execution of such contracts. In pursuance of this policy, GSCDL.
  - (a) defines, for the purposes of this provision, the terms set forth below as follows:
    - i. "Corrupt practice" means the offering, giving, receiving, or soliciting, directly or indirectly, anything of value to influence improperly the actions of another party;
    - ii. "fraudulent practice" means any act or omission, including a misrepresentation, that knowingly or recklessly misleads, or attempts to mislead, a party to obtain a financial or other benefit or to avoid an obligation;
    - iii. "Coercive practice" means impairing or harming or threatening to harm, directly or indirectly, any party or the property of the party to influence improperly the actions of a party;
    - iv. "collusive practice" means an arrangement between two or more parties designed to achieve an improper purpose, including, influencing improperly the actions of another party;

- (b) will reject a proposal for award if it determines that the bidder recommended for award has, directly or through an agent, engaged in corrupt, fraudulent, collusive, or coercive practices in competing for the Contract;
- (c) will sanction a firm or an individual, at any time, in accordance with the Anti-Corruption Policy and integrity Principles and guidelines (both as amended from time to time), including declaring in-eligible, either indefinitely or a stated period of time, to participate in GSCDL financed or GSCDL administered activities or to benefit from an GSCDL-finance or GSCDL-administered contract, financially or otherwise, if it at any time determines that the firm or individual has, directly or through an agent, engaged in corrupt fraudulent, collusive or coercive or other prohibited practices.
- (d) Will have the right to require that a provision be included in Bidding Documents and in contracts financed by GSCDL, requiring bidders, suppliers and contractors and consultants to permit the GSCDL to inspect their accounts and records and other documents relating to the Bid Submission and Contract Performance and to have them audited by auditors appointed by GSCDL.
- (e) Will cancel the portion of the financing allotted to contract if it determines at any time that representatives of the contractor or of a beneficiary or GSCDL financing engaged in corrupt, fraudulent, collusive or coercive or other prohibited practice during the procurement or the execution of the contract, without the borrower having taken timely and appropriate actions satisfactory to GSCDL to remedy the situation

3.2. Furthermore, Bidders shall be aware of the provisions of GCC 22.2 and 56.2 (h).

#### **4. Eligible Bidders**

- 4.1. A Bidder may be a natural person, private entity, government-owned entity—subject to ITB 4.5—or any combination of them in the form of a Joint Venture (JV) under an existing agreement or with the intent to constitute a legally-enforceable joint venture, coming together to implement the Project. In the case of a JV:
  - a. The word Bidder, wherever applicable, shall include all the members of the Joint Venture. In that case, all the references to the Bidder in this document must construe to the reference to all the members of the Joint Venture also.
  - b. All partners shall be jointly and severally liable for the execution of the Contract in accordance with the Contract terms, and
  - c. The JV shall nominate a representative who shall have the authority to conduct all business for and on behalf of any and all the parties.
  - d. of the JV during the bidding process and, in the event the JV is awarded the Contract, during contract execution.
- 4.2. A Bidder, and all parties constituting the Bidder, shall have the Indian nationality. A Bidder shall be deemed to have the nationality of a country if the Bidder is a citizen or is constituted, or incorporated, and operates in conformity with the provisions of the laws of that country. This criterion shall also apply to the determination of the nationality of proposed subcontractors or suppliers for any part of the Contract including related services.

- 4.3. GSCDL considers a conflict of interest to be a situation in which a party has interests that could improperly influence that party's performance of official duties or responsibilities, contractual obligations, or compliance with applicable laws and regulations, and that such conflict of interest may contribute to or constitute a prohibited practice under GSCDL's Anticorruption Policy. In pursuance of GSCDL's Anticorruption Policy's requirement that bidders, suppliers, subcontractors and contractors under GSCDL-financed contracts, observe the highest standard of ethics, GSCDL will take appropriate actions, which include not financing of the contract, if it determines that a conflict of interest has flawed the integrity of any procurement process. Consequently, all Bidders found to have a conflict of interest shall be disqualified. A Bidder may be considered to be in a conflict of interest with one or more parties in this bidding process if, including but not limited to:
- a. they have controlling shareholders in common; or
  - b. they receive or have received any direct or indirect subsidy from any of them; or
  - c. they have the same legal representative for purposes of this bid; or
  - d. they have a relationship with each other, directly or through common third parties, that puts them in a position to have access to information about or influence on the Bid of another Bidder, or influence the decisions of the Employer regarding this bidding process; or
  - e. A Bidder participates in more than one bid in this bidding process. Participation by a Bidder in more than one Bid will result in the disqualification of all Bids in which the party is involved. However, this does not limit the inclusion of the same subcontractor in more than one bid; not otherwise participating as a Bidder.
  - f. A Bidder or any of its affiliates participated as a consultant in the preparation of the design or technical specifications of the contract that is the subject of the Bid; or
  - g. A Bidder or any of its affiliates has been hired (or is proposed to be hired) by the Employer as Engineer for the contract.
- 4.4. A firm that is under a declaration of ineligibility by the GSCDL in accordance with ITB 3, at the date of the deadline for bid submission or thereafter, shall be disqualified. A bid from a sanctioned or cross debarred firm by any government agencies of Employers country will be rejected. It is the duty of the Contractor/Bidder to notify employer if the Contractor/Bidder is being debarred by any agencies as mentioned above. The contractor bid will be summarily terminated even after contract has been awarded if it is found to in case of any such information comes to the notice of Employer in such an event the contractor will be liable for all losses and liabilities of Employers as well as of contractors firm.
- 4.5. Government-owned enterprises in the Employer's country shall be eligible only if they can establish that they are legally and financially autonomous and operate under commercial law, and that they are not a dependent agency of the employer.
- 4.6. Bidders shall provide such evidence of their continued eligibility satisfactory to the Employer, as the Employer shall reasonably request.



4.7. In case a prequalification process has been conducted prior to the bidding process, this bidding is open only for prequalified bidders.

## **5. Eligible Materials, Equipment and Services**

5.1. The materials, equipment and services to be supplied under the Contract shall have their origin in eligible source countries as defined in ITB 4.2 above and all expenditures under the Contract will be limited to such materials, equipment, and services. At the Employer's request, Bidders may be required to provide evidence of the origin of materials, equipment and services.

5.2. For purposes of ITB 5.1 above, "origin" means the place where the materials and equipment are mined, grown, produced or manufactured, and from which the services are provided. Materials and equipment are produced when, through manufacturing, processing, or substantial or major assembling of components, a commercially recognized product results that differs substantially in its basic characteristics or in purpose or utility from its components.

### **Contents of Bidding Documents**

## **6. Sections of Bidding Document**

6.1. The Bidding Document consist of Parts I, II, and III, which include all the Sections indicated below, and should be read in conjunction with any Addenda issued in accordance with ITB 8.

### **PART I Bidding Procedures**

Section 1 - Instructions to Bidders (ITB)

Section 2 - Bid Data Sheet (BDS)

Section 3 - Evaluation and Qualification Criteria (EQC)

Section 4 - Bidding Forms (BDF)

Section 5 - Schedules-Bill Of Quantity

### **PART II Requirements**

Section 6 - Works Requirements (WRQ)

### **PART III Conditions of Contract and Contract Forms**

Section 7 - General Conditions (GCC)

Section 8 - Particular Conditions (PCC)

Section 9 - Contract Forms (COF)

6.2. The Invitation for Bids issued by the Employer is not part of the Bidding Document.

6.3. The Employer is not responsible for the completeness of the Bidding Document and their Addenda, if they were not obtained directly from the source stated by the Employer in the Invitation for Bids.

6.4. The Bidder is expected to examine all instructions, forms, terms, and specifications in the Bidding Document. Failure to furnish all information or documentation required by the Bidding Document may result in the rejection of the bid.

## **7. Clarification of Bidding Document, Site Visit, Pre-Bid Meeting:**

7.1. A prospective Bidder requiring any clarification of the Bidding Document shall contact the Employer in writing at the Employer's address indicated in the BDS or raise his inquiries during the pre-bid meeting if provided for in accordance with ITB 7.4. The Employer will respond in writing to any request for clarification, provided that such request is received prior to the deadline for submission of bids, within a period given in the BDS. The Employer shall forward copies of its response to all Bidders who have acquired the Bidding Document in accordance with ITB 6.3, including a description of the inquiry but without identifying its source. Should the Employer

deem it necessary to amend the Bidding Document as a result of a request for clarification, it shall do so following the procedure under ITB 8 and ITB 22.2.

- 7.2. The Bidder is encouraged to visit and examine the Site of Works and its surroundings and obtain for itself on its own risk and responsibility all information that may be necessary for preparing the bid and entering into a contract for construction of the Works. The costs of visiting the Site shall be at the Bidder's own expense.
- 7.3. The Bidder and any of its personnel or agents will be granted permission by the Employer to enter upon its premises and lands for the purpose of such visit, but only upon the express condition that the Bidder, its personnel, and agents will release and indemnify the Employer and its personnel and agents from and against all liability in respect thereof, and will be responsible for death or personal injury, loss of or damage to property, and any other loss, damage, costs, and expenses incurred as a result of the inspection.
- 7.4. The Bidder's designated representative is invited to attend a pre-bid meeting, if provided for in the BDS. The purpose of the meeting will be to clarify issues and to answer questions on any matter that may be raised at that stage.
- 7.5. The Bidder is requested, as far as possible, to submit any questions in writing, to reach the Employer not later than three days before the meeting.
- 7.6. Minutes of the pre-bid meeting, including the text of the questions raised, without identifying the source, and the responses given, together with any responses prepared after the meeting, will be transmitted promptly to all Bidders who have acquired the Bidding Document in accordance with ITB 6.3. Any modification to the Bidding Document that may become necessary as a result of the pre-bid meeting shall be made by the Employer exclusively through the issue of an addendum pursuant to ITB 8 and not through the minutes of the pre-bid meeting.
- 7.7. Nonattendance at the pre-bid meeting will not be a cause for disqualification of a Bidder.

## **8. Amendment of Bidding Document**

- 8.1. At any time prior to the deadline for submission of bids, the Employer may amend the Bidding Document by issuing addenda.
- 8.2. Any addendum issued shall be part of the Bidding Document and shall be communicated in writing to all who have obtained the Bidding Document from the Employer in accordance with ITB 6.3.
- 8.3. To give prospective Bidders reasonable time in which to take an addendum into account in preparing their bids, the Employer may, at its discretion, extend the deadline for the submission of bids, pursuant to ITB 22.2.

### **Preparation of Bids**

## **9. Cost of Bidding**

- 9.1. The Bidder shall bear all costs associated with the preparation and submission of its Bid, and the Employer shall in no case be responsible or liable for those costs, regardless of the conduct or outcome of the bidding process.

## **10. Language of Bid**

- 10.1. The Bid, as well as all correspondence and documents relating to the bid exchanged by the Bidder and the Employer, shall be written in the language specified in the BDS. Supporting documents and printed literature that are part of the Bid may be in another language provided they are accompanied by an accurate translation of the relevant passages in the language

specified in the BDS, in which case, for purposes of interpretation of the Bid, such translation shall govern.

## **11. Documents Comprising the Bid**

- 11.1. The Bid shall comprise two envelopes submitted simultaneously, one called the Technical Bid containing the documents listed in ITB 11.2 and the other the Price Bid containing the documents listed in ITB 11.3, both envelopes enclosed together in an outer single envelope.
- 11.2. The Technical Bid shall comprise the following:
  - I. Letter of Technical Bid;
  - II. Bid Security, in accordance with ITB 19;
  - III. alternative bids, if permissible, in accordance with ITB 13;
  - IV. written confirmation authorizing the signatory of the Bid to commit the Bidder, in accordance with ITB 20.2;
  - V. documentary evidence in accordance with ITB 17 establishing the Bidder's qualifications to perform the contract;
  - VI. Technical Proposal in accordance with ITB 16;
  - VII. Any other document required in the BDS.
- 11.3. The Price Bid shall comprise the following.
  - (a) Letter of Price Bid;
  - (b) completed Price Schedules, in accordance with ITB 12 and 14, or as stipulated in the BDS;
  - (c) alternative price bids, at Bidder's option and if permissible, in accordance with ITB 13;
  - (d) Any other document required in the BDS.
- 11.4. In addition to the requirements under ITB 11.2, bids submitted by a JV shall include a copy of the Joint Venture Agreement entered into by all the partners. Alternatively, a letter of Intent to execute a Joint Venture Agreement in the event of a successful bid shall be signed by all partners and submitted with the bid, together with a copy of the proposed agreement

## **12. Letters of Bid, and Schedules**

- 12.1. The Letters of Technical bid and Price bid, and all documents listed under Clause 11, i.e. Schedules, including the Bill of Quantities etc., shall be prepared using the relevant forms furnished in Section 4 (Bidding Forms) if so provided. The forms must be completed without any alterations to the text, and no substitutes shall be accepted. All blank spaces shall be filled in with the information requested.

## **13. Alternative Bids**

- 13.1. Unless otherwise indicated in the BDS, alternative bids shall not be considered.
- 13.2. When alternative times for completion are explicitly invited, a statement to the effect will be included in the BDS, as will be the method of evaluating different times of completion.
- 13.3. When specified in the BDS pursuant to ITB 13.1, and subject to ITB 13.4 below, Bidders wishing to offer technical alternatives to the requirements of the Bidding Document must first price the Employer's design as described in the Bidding Document and shall further provide all information necessary for a complete evaluation of the alternative by the Employer, including drawings, design calculations technical specifications, breakdown of prices, and proposed construction methodology and other relevant details. Only the technical alternatives,

if any, of the lowest evaluated Bidder conforming to the basic technical requirements shall be considered by the Employer.

- 13.4. When specified in the BDS, Bidders are permitted to submit alternative technical solutions for specified parts of the Works. Such parts will be identified in the BDS and described in Section 6 (Works Requirements). The method for their evaluation will be stipulated in Section 3 (Evaluation and Qualification Criteria).

#### **14. Bid Prices and Discounts**

- 14.1. The prices and discounts quoted by the Bidder in the Letter of Price Bid and in the Bill of Quantities shall conform to the requirements specified below.
- 14.2. The Bidder shall submit a bid for whole of the works described in ITB 1.1 by filling in prices for all items of Works, as identified in Section 4 (Bidding forms). In case of admeasurements contracts, the bidder shall fill in rates and prices for all items of the Works described in the Bill of Quantities. Items against which no rate or price is entered by the Bidder will not be paid for by the Employer when executed and shall be deemed covered by the rates for other items and prices in the Bill of Quantities.
- 14.3. The price to be quoted in the Letter of Price Bid, in accordance with ITB 12.1 shall be the total price of the Bid, excluding any discounts offered.
- 14.4. The Bidder shall quote Unconditional discounts, if any, and the methodology for their application in the Letter of Price Bid, in accordance with ITB 14.1.
- 14.5. If so indicated in ITB 1.1, bids are invited for individual contracts or for any combination of contracts (packages), Bidders wishing to offer any price reduction for the award of more than one Contract shall specify in their bid the price reductions applicable to each package, or alternatively, to individual Contracts within the package. Price reductions or discounts shall be submitted in accordance with ITB 14.4, provided the bids for all contracts are submitted and opened at the same time.
- 14.6. Unless otherwise provided in the BDS and the Conditions of Contract, the prices quoted by the Bidder shall be fixed. If the prices quoted by the Bidder are subject to adjustment during the performance of the Contract in accordance with the provisions of the Conditions of Contract, the Bidder shall furnish the indices and weightings for the price adjustment formulae in the Schedule of Adjustment Data in Section 4 (Bidding Forms) and the Employer may require the Bidder to justify its proposed indices and weightings.
- 14.7. All duties, taxes, and other levies payable by the Contractor under the Contract, or for any other cause, as of the date 28 days prior to the deadline for submission of bids, shall be included in the rates and prices and the total Bid Price submitted by the Bidder.

#### **15. Currencies of Bid and Payment**

- 15.1. The currency(is) of the bid and payment shall be as specified in the BDS.

#### **16. Documents Comprising the Technical Proposal**

- 16.1. The Bidder shall furnish, as a part of the Technical bid, a Technical Proposal including a statement of work methods, equipment, personnel, schedule and any other information as stipulated in Section 4 (Bidding Forms), in sufficient detail to demonstrate the adequacy of the Bidders' proposal to meet the work requirements and the completion time.

#### **17. Documents Establishing the Qualifications of the Bidder**

- 17.1. To establish its qualifications to perform the Contract in accordance with Section 3 (Evaluation and Qualification Criteria) the Bidder shall provide the information requested in the corresponding information sheets included in Section 4 (Bidding Forms).
- 17.2. Domestic Bidders, individually or in joint ventures, applying for eligibility for domestic preference shall supply all information required to satisfy the criteria for eligibility as described in ITB 35.

#### **18. Period of Validity of Bids**

- 18.1. Bids shall remain valid for the period specified in the BDS after the bid submission deadline date prescribed by the Employer. A bid valid for a shorter period shall be rejected by the Employer as non-responsive.
- 18.2. In exceptional circumstances, prior to the expiration of the bid validity period, the Employer may request Bidders to extend the period of validity of their Bids. The request and the responses shall be made in writing. If a bid security is requested in accordance with ITB 19, it shall also be extended for a corresponding period. A Bidder may refuse the request without forfeiting its bid security. A Bidder granting the request shall not be required or permitted to modify its Bid.

#### **19. Bid Security**

- 19.1. Unless otherwise specified in the BDS, the Bidder shall furnish as part of its bid, in original form, either Bid Securing Declaration or a Bid Security as specified in the BDS. In case of Bid Security the amount shall be as specified in the BDS.
- 19.2. A Bid Securing Declaration shall use the form included in Section 4 (Bidding Forms).
- 19.3. If a bid security is specified pursuant to ITB 19.1, the bid security shall be, at the Bidder's option, in any of the following forms:
  - (a) an unconditional Bank Guarantee;  
In the case of a Bank Guarantee, the Bid Security shall be submitted either using the Bid Security Form included in Section 4 (Bidding Forms) or another form acceptable to the Employer. The form must include the complete name of the Bidder. The Bid Security shall be valid for twenty-eight days (28) beyond the original validity period of the bid, or beyond any period of extension if requested under ITB 18.2.
- 19.4. Any Bid not accompanied by to substantially compliant Bid Security, if required in accordance with ITB 19.3, or Bid Securing declaration in accordance with ITB 19.2, if required in accordance with ITB 19.1 shall be rejected by the Employer as non-responsive.
- 19.5. If a Bid Security is specified pursuant to ITB 19.1, the Bid Security of unsuccessful Bidders shall be returned as promptly as possible upon the successful Bidder's furnishing of the Performance Security pursuant to ITB 43.1.
- 19.6. If a Bid Security is specified pursuant to ITB 19.1, the Bid Security of the successful Bidder shall be returned as promptly as possible once the successful Bidder has signed the Contract and furnished the required Performance Security.
- 19.7. The Bid Security may be forfeited or the Bid Securing Declaration executed:
  - (a) if a Bidder withdraws its bid during the period of bid validity specified by the Bidder on the Letter of Bid, except as provided in ITB 18.2 or
  - (b) if the successful Bidder fails to:
    - i. sign the Contract in accordance with ITB 42;
    - ii. furnish a Performance Security in accordance with ITB 43.1.

- iii. accept the correction of its Bid price pursuant to ITB 33.2
- 19.8. The Bid Security or the Bid Securing Declaration of a JV shall be in the name of the JV that submits the bid. If the JV has not been legally constituted at the time of bidding, Bid Security or the Bid Securing Declaration shall be in the names of all future partners as named in the letter of intent mentioned in ITB 4.1.

## **20. Format and Signing of Bid**

- 20.1. The Bidder shall prepare one original of the documents comprising the bid as described in ITB 11 and clearly mark it "ORIGINAL-TECHNICAL BID AND ORIGINAL-PRICE BID". Alternative bids, if permitted in accordance with ITB 13, shall be clearly marked "ALTERNATIVE". In addition, the Bidder shall submit copies of the bid, in the number specified in the BDS, and clearly mark each of them "COPY". In the event of any discrepancy between the original and the copies, the original shall prevail.
- 20.2. The original and all copies of the Bid shall be typed or written in indelible ink and shall be signed by a person duly authorized to sign on behalf of the Bidder. This authorization shall consist of a written confirmation as specified in the BDS and shall be attached to the bid. The name and position held by each person signing the authorization must be typed or printed below the signature.
- 20.3. Any amendments such as interlineations, erasures, or overwriting shall be valid only if they are signed or initialed by the person signing the Bid.

### **Submission and Opening of Bids**

## **21. Sealing and Marking of Bids**

- 21.1. Bidders may always submit their bids by mail or by hand. When so specified in the BDS, bidders shall have the option of submitting their bids electronically. Procedures for submission, sealing and marking are as follows.
- (a) Bidder shall enclose the original of the Technical Bid, the original of the Price Bid, and each copy of the Technical Bid and each copy of the Price Bid, including alternative bids, if permitted in accordance with ITB 13, in separate sealed envelopes, duly marking the envelopes as "ORIGINAL - TECHNICAL BID", "ORIGINAL - PRICE BID" and "COPY NO... - TECHNICAL BID" and "COPY NO.... - PRICE BID." These envelopes, the first containing the originals and the others containing copies, shall then be enclosed in one single envelope per set.
  - (b) Bidders submitting bids electronically shall follow the electronic bid submission procedures specified in the BDS.
- 21.2. The inner and outer envelopes shall:
- (c) bear the name and address of the Bidder;
  - (d) be addressed to the Employer as provided in BDS 22.1;
  - (e) bear the specific identification of this bidding process indicated in the BDS 1.1; and
- 21.3. The outer envelopes and the inner envelopes containing the Technical Bid shall bear a warning not to open before the time and date for the opening of Technical Bid, in accordance with ITB Sub-Clause 25.1.
- 21.4. The inner envelopes containing the Price Bid shall bear a warning not to open until advised by the Employer in accordance with ITB Sub-Clause 25.1.

- 21.5. Alternative Bids, if permissible in accordance with ITB Clause 13, shall be prepared, sealed, marked, and delivered in accordance with the provisions of ITB Clauses 20 and 21, with the inner envelopes marked in addition "ALTERNATIVE NO...." as appropriate.
- 21.6. If all envelopes are not sealed and marked as required, the Employer will assume no responsibility for the misplacement or premature opening of the bid.

## **22. Deadline for Submission of Bids**

- 22.1. Bids must be received by the Employer at the address and no later than the date and time indicated in the BDS.
- 22.2. The Employer may, at its discretion, extend the deadline for the submission of bids by amending the Bidding Document in accordance with ITB 8, in which case all rights and obligations of the Employer and Bidders previously subject to the deadline shall thereafter be subject to the deadline as extended.

## **23. Late Bids**

- 23.1. The Employer shall not consider any bid that arrives after the deadline for submission of bids, in accordance with ITB 22. Any bid received by the Employer after the deadline for submission of bids shall be declared late, rejected, and returned unopened to the Bidder.

## **24. Withdrawal of Bids**

- 24.1. A Bidder may withdraw, substitute, or modify its Bid – Technical or Price – after it has been submitted by sending a written notice, duly signed by an authorized representative, and shall include a copy of the authorization in accordance with ITB 20.2, (except that withdrawal notices do not require copies). The corresponding substitution or modification of the bid must accompany the respective written notice. All notices must be:
- (a) prepared and submitted in accordance with ITB 20 and ITB 21 (except that withdrawal notices do not require copies), and in addition, the respective envelopes shall be clearly marked "WITHDRAWAL," "SUBSTITUTION," "MODIFICATION;" and
  - (b) received by the Employer prior to the deadline prescribed for submission of bids, in accordance with ITB 22.
- 24.2. Bids requested to be withdrawn in accordance with ITB 24.1 shall be returned unopened to the Bidders.
- 24.3. No bid may be withdrawn, substituted, or modified in the interval between the deadline for submission of bids and the expiration of the period of bid validity specified by the Bidder on the Letter of Bid or any extension thereof.

## **25. Bid Opening**

- 25.1. The Employer shall open the Technical bids in public at the address, date and time specified in the BDS in the presence of Bidder's designated representative and anyone who chose to attend. Any specific electronic bid opening procedures required if electronic bidding is permitted in accordance with ITB 21.1 shall be as specified in the BDS. The Price bids will remain unopened and will be held in the custody of the Employer until the specified time of their opening.
- 25.2. First, envelopes marked "WITHDRAWAL" shall be opened and read out and the envelope with the corresponding bid shall not be opened, but returned to the Bidder. No bid withdrawal shall be permitted unless the corresponding withdrawal notice contains a valid authorization to request the withdrawal and is read out at bid opening.

- 25.3. Second, outer envelopes marked "SUBSTITUTION" shall be opened. The inner envelopes containing the Substitution Technical Bid and/or Substitution Price Bids shall be exchanged for the corresponding envelopes being substituted, which are to be returned to the Bidder unopened. Only the substitution Technical Bid, if any, shall be opened, read out and recorded. Substitution Price Bid will remain unopened in accordance with ITB Sub-Clause 25.1. No envelope shall be substituted unless the corresponding Substitution Notice contains a valid authorization to request the substitution and is read out and recorded at bid opening.
- 25.4. Next, outer envelopes marked "MODIFICATION" shall be opened. No Technical Bid and/or Price Bid shall be modified unless the corresponding Modification Notice contains a valid authorization to request the modification and is read out and recorded at the opening of Technical Bids. Only the Technical Bids, both Original as well as Modification is to be opened, read out, and recorded at the opening. Price Bids, both Original and Modification, will remain unopened in accordance with ITB Sub-Clause 25.1.
- 25.5. All other envelopes holding the Technical Bids shall be opened one at a time, and the following read out and recorded:
- (a) the name of the Bidder;
  - (b) Whether there is a modification or substitution
  - (c) the presence of a Bid Security, if required; and
  - (d) any other details as the Employer may consider appropriate.
- Only Technical Bids and alternative Technical bids read out and recorded at bid opening shall be considered for evaluation. No Bid shall be rejected at the opening of Technical Bids except for late bids, in accordance with ITB Sub-Clause 23.1.
- 25.6. The Employer shall prepare a record of the opening of Technical Bids that shall include, as a minimum: the name of the Bidder and whether there is withdrawal, substitution or modification, alternative proposals and the presence or absence of a bid security, if one was required. The Bidders' representatives who are present shall be requested to sign the record. The omission of a Bidder's signature on the record shall not invalidate the contents and effect of the record. A copy of the record shall be distributed to all Bidders.
- 25.7. At the end of the evaluation of the Technical Bids, the Employer will invite bidders who have submitted substantially responsive Technical Bids and who have been determined as being qualified for award to attend the opening of the Price Bids. The date, time, and location of the opening of Price Bids will be advised in writing by the Employer. Bidders shall be given reasonable notice of the opening of Price Bids.
- 25.8. The Employer will notify Bidders in writing who have been rejected on the grounds of their Technical Bids being substantially non-responsive to the requirements of the Bidding Document and return their Price Bids unopened.
- 25.9. The Employer shall conduct the opening of Price Bids of all Bidders who submitted substantially responsive Technical Bids, in the presence of Bidders' representatives who choose to attend at the address, date and time specified by the Employer. The Bidder's representatives who are present shall be requested to sign a register evidencing their attendance.
- 25.10. All envelopes containing Price Bids shall be opened one at a time and the following read out and recorded:
- (a) the name of the Bidder;



- (b) Whether there is a modification or substitution,
- (c) the Bid Prices, including any discounts; and alternative offers, and
- (d) any other details as the Employer may consider appropriate.

Only Price Bids, discounts, and alternative offers read out and recorded during the opening of Price Bids shall be considered for evaluation. No Bid shall be rejected at the opening of Price Bids.

- 25.11. The Employer shall prepare a record of the opening of Price Bids that shall include, as a minimum: the name of the Bidder, the Bid Price (per lot if applicable), any discounts, and alternative offers. The Bidders' representatives who are present shall be requested to sign the record. The omission of a Bidder's signature on the record shall not invalidate the contents and effect of the record. A copy of the record shall be distributed to all Bidders.

### **Evaluation and Comparison of Bids**

#### **26. Confidentiality**

- 26.1. Information relating to the examination, evaluation, comparison, and post qualification of bids and recommendation of contract award, shall not be disclosed to Bidders or any other persons not officially concerned with such process until information on Contract award is communicated to all Bidders.
- 26.2. Any attempt by a Bidder to influence the Employer in the evaluation of the bids or Contract award decisions may result in the rejection of its Bid.
- 26.3. Notwithstanding ITB 26.2, from the time of bid opening to the time of Contract award, if any Bidder wishes to contact the Employer on any matter related to the bidding process, it may do so in writing.

#### **27. Clarification of Bids**

- 27.1. To assist in the examination, evaluation, and comparison of the Technical and Price bids, and qualification of the Bidders, the Employer may at its discretion ask any Bidder for a clarification of its bid. Any clarification submitted by a Bidder that is not in response to a request by the Employer shall not be considered. The Employer's request for clarification and the response shall be in writing. No change in substance of the Technical bid or prices in the price bid shall be sought, offered, or permitted, except to confirm the correction of arithmetic errors discovered by the Employer in the evaluation of the bids, in accordance with ITB 33.
- 27.2. If a Bidder does not provide clarifications of its bid by the date and time set in the Employer's request for clarification, its bid may be rejected.

#### **28. Deviations, Reservations, and Omissions**

- 28.1. During the evaluation of bids, the following definitions apply:
- (a) "Deviation" is a departure from the requirements specified in the Bidding Document;
  - (b) "Reservation" is the setting of limiting conditions or withholding from complete acceptance of the requirements specified in the Bidding Document; and
  - (c) "Omission" is the failure to submit part or all of the information or documentation required in the Bidding Document.

#### **29. Preliminary Examination of Technical Bids**

- 29.1. The Employer shall examine the Technical Bid to confirm that all documents and technical documentation requested in ITB Sub-Clause 11.2 have been provided, and to determine the completeness of each document submitted.

- 29.2. The Employer shall confirm that the following documents and information have been provided in the Technical Bid.
- (a) Letter of Technical Bid
  - (b) Written confirmation of authorization to commit the Bidder
  - (c) Bid Security, if applicable and
  - (d) Technical Proposal in accordance with ITB 16

**30. Responsiveness of Technical Bid**

- 30.1. The Employer's determination of a bid's responsiveness will be based on the contents of the bid itself, as defined in ITB11.
- 30.2. A substantially responsive Technical bid is one that meets the requirements of the Bidding Document without material deviation, reservation, or omission. A material deviation, reservation, or omission is one that,
- (a) if accepted, would:
    - i. Affect in any substantial way the scope, quality, or performance of the Works specified in the Contract; or
    - ii. Limit in any substantial way, inconsistent with the Bidding Document, the Employer's rights or the Bidder's obligations under the proposed Contract; or
  - (b) if rectified, would unfairly affect the competitive position of other Bidders presenting substantially responsive bids.
- 30.3. The Employer shall examine the technical aspects of the bid submitted in accordance with ITB 16, Technical Proposal, in particular, to confirm that all requirements of Section 6 (Works Requirements) have been met without any material deviation, reservation or omission.
- 30.4. If a bid is not substantially responsive to the requirements of the Bidding Document, it shall be rejected by the Employer and may not subsequently be made responsive by correction of the material deviation, reservation, or omission.

**31. Nonconformities, Errors, and Omissions**

- 31.1. Provided that a bid is substantially responsive, the Employer may waive any nonconformity in the bid that does not constitute a material deviation, reservation or omission.
- 31.2. Provided that a Technical bid is substantially responsive, the Employer may request that the Bidder submit the necessary information or documentation, within a reasonable period of time, to rectify nonmaterial nonconformities in the Technical bid related to documentation requirements. Requesting information or documentation on such nonconformities shall not be related to any aspect of the price of the bid. Failure of the Bidder to comply with the request may result in the rejection of its bid.
- 31.3. Provided that a Technical bid is substantially responsive, the Employer shall rectify quantifiable nonmaterial nonconformities related to the Bid Price. To this effect, the Bid Price may be adjusted, for comparison purposes only, to reflect the price of a missing or non-conforming item or component. The adjustment shall be made using the methods indicated in Section 3 (Evaluation and Qualification Criteria).

**32. Qualification of the Bidder**

- 32.1. The Employer shall determine to its satisfaction during the evaluation of Technical Bids whether Bidders meet the qualifying criteria specified in Section 3 (Evaluation and Qualification Criteria).

32.2. The determination shall be based upon an examination of the documentary evidence of the Bidder's qualifications submitted by the Bidder, pursuant to ITB 17.1.

32.3. An affirmative determination shall be a prerequisite for the opening and evaluation of a Bidder's Price Bid. A negative determination shall result into the disqualification of the Bid, in which event the Employer shall return the unopened Price Bid to the Bidder.

### **33. Correction of Arithmetical Errors**

33.1. During the evaluation of Price Bids, the Employer shall correct arithmetical errors on the following basis:

- (a) if there is a discrepancy between the unit price and the total price that is obtained by multiplying the unit price and quantity, the unit price shall prevail and the total price shall be corrected, unless in the opinion of the Employer there is an obvious misplacement of the decimal point in the unit price, in which case the total price as quoted shall govern and the unit price shall be corrected;
- (b) if there is an error in a total corresponding to the addition or subtraction of subtotals, the subtotals shall prevail and the total shall be corrected; and
- (c) if there is a discrepancy between words and figures, the amount in words shall prevail, unless the amount expressed in words is related to an arithmetic error, in which case the amount in figures shall prevail subject to (a) and (b) above.
- (d) If there is a discrepancy in the ORIGINAL and COPY, the figures given in ORIGINAL shall prevail.

33.2. If the Bidder that submitted the lowest evaluated bid does not accept the correction of errors, its Bid shall be disqualified and its bid security may be forfeited.

### **34. Conversion to Single Currency**

34.1. For evaluation and comparison purposes, the currency(ies) of the bid shall be converted into a single currency as specified in the BDS.

### **35. Margin of Preference**

35.1. Unless otherwise specified in the BDS, a margin of preference shall not apply.

### **36. Preliminary Examination of Price Bids**

Deleted

### **37. Evaluation of Price Bids**

37.1. The Employer shall use the criteria and methodologies listed in this Clause. No other evaluation criteria or methodologies shall be permitted.

37.2. To evaluate bid price, the Employer shall consider the following:

- (a) the bid price, excluding Provisional Sums and the provision, if any, for contingencies in the Summary Bill of Quantities for admeasurements contracts, or Schedule of Prices for lump sum contracts, but including Day work items, where priced competitively;
- (b) price adjustment for correction of arithmetic errors in accordance with ITB 33.1;
- (c) price adjustment due to discounts offered in accordance with ITB 14.4;
- (d) converting the amount resulting from applying (a) to (c) above, if relevant, to a single currency in accordance with ITB 34;
- (e) adjustment for nonconformities in accordance with ITB 31.3;
- (f) application of all the evaluation factors indicated in Section 3 (Evaluation and Qualification Criteria);

- 37.3. The estimated effect of the price adjustment provisions of the Conditions of Contract, applied over the period of execution of the Contract, shall not be taken into account in bid evaluation.
- 37.4. If this Bidding Document allows Bidders to quote separate prices for different contracts, and to award multiple contracts to a single Bidder, the methodology to determine the lowest evaluated price of the contract combinations, including any discounts offered in the Letter of Bid, is specified in Section 3 (Evaluation and Qualification Criteria).
- 37.5. If the Bid for an admeasurements contract, which results in the lowest Evaluated Bid Price is seriously unbalanced, front loaded or substantially below updated estimates in the opinion of the Employer, the Employer may require the Bidder to produce detailed price analyses for any or all items in the Bill of Quantities, to demonstrate the internal consistency of those prices with the construction methods and schedule proposed. After evaluation of the price analyses, taking into consideration the schedule of estimated Contract payments, the Employer may require that the amount of the Performance Security be increased at the expense of the Bidder to a level sufficient to protect the Employer against financial loss in the event of default of the successful Bidder under the Contract.

### **38. Comparison of Bids**

- 38.1. The Employer shall compare all substantially responsive bids to determine the lowest evaluated bid in accordance with ITB 37.2.

### **39. Employer's Right to Accept Any Bid, and to Reject Any or All Bids**

- 39.1. The Employer reserves the right to accept or reject any bid, and to annul the bidding process and reject all bids at any time prior to contract award, without thereby incurring any liability to Bidders. In case of annulment, all bids submitted and specifically, bid securities, shall be promptly returned to the Bidders.

## **Award of Contract**

### **40. Award Criteria**

- 40.1. The Employer shall award the Contract to the Bidder whose offer has been determined to be the lowest evaluated bid and is substantially responsive to the Bidding Document, provided further that the Bidder is determined to be qualified to perform the Contract satisfactorily.

### **41. Notification of Award**

- 41.1. Prior to the expiration of the period of bid validity, the Employer shall notify the successful Bidder, in writing, that its bid has been accepted. The Notification letter (hereinafter and in the conditions of contract and contract forms called "The Letter of Acceptance"), shall specify the sum that the Employer will pay the contractor in consideration of the execution and completion of the works. (Hereinafter and in the conditions of contract and contract forms called "The Contract Price").
- 41.2. Until a formal contract is prepared and executed, the notification of award shall constitute a binding Contract.
- 41.3. At the same time, the Employer shall also notify all other Bidders of the results of the bidding and shall publish in an English language newspaper or well-known freely accessible website the results identifying the bid and contract numbers and the following information: (i) name of each Bidder who submitted a Bid; (ii) bid prices as read out at Bid Opening; (iii) name and evaluated prices of each Bid that was evaluated; (iv) name of bidders whose bids were

rejected and the reasons for their rejection; and (v) name of the winning Bidder, and the Price it offered , as well as the duration and summary scope of the contract awarded. After publication of the award, unsuccessful bidders may request in writing to the Employer a debriefing seeking explanations on the grounds on which their bids were not selected. The Employer shall promptly respond in writing to any unsuccessful Bidder who, after publication of contract award, requests a debriefing.”

The Employer shall promptly respond in writing to any unsuccessful Bidder who requests in writing the grounds on which its bid was not selected.

#### **42. Signing of Contract**

- 42.1. Promptly after notification, the Employer shall send the successful Bidder the Contract Agreement.
- 42.2. Within fifteen (15) days of receipt of the Contract Agreement, the successful Bidder shall sign, date, and return it to the Employer.

#### **43. Performance Security**

- 43.1. Within fifteen (15) days of the receipt of notification of award from the Employer, the successful Bidder shall furnish the Performance Security in accordance with the Conditions Of Contract, subject to ITB 37.5, using for that purpose the Performance Security Form included in Section 9 (Contract Forms), or another form acceptable to the Employer. If the institution issuing the Performance Security is located outside the country of the Employer, it shall have a correspondent financial institution located in the country of the Employer to make it enforceable.
- 43.2. Failure of the successful Bidder to submit the above-mentioned Performance Security or to sign the Contract Agreement shall constitute sufficient grounds for the annulment of the award and forfeiture of the Bid Security. In that event the Employer may award the Contract to the next lowest evaluated Bidder whose offer is substantially responsive and is determined by the Employer to be qualified to perform the Contract satisfactorily.
- 43.3. The above provision shall apply for furnishing of a domestic preference security if so required.

## Section 2 - Bid Data Sheet

### A. Introduction

This Section Consists of Provisions that are Specific to each procurement and Supplement the information and requirements included in Section 1 – Instructions to Bidders.

ITB 1.1	The number of the Invitation for Bids is:
ITB 1.1	The Employer is: Gangtok Smart City Development Limited
ITB 1.1	<p>The name of the bidding process is: Request for Proposal (RFP)</p> <p>The name of the RFP is: <b>Improvement of Pedestrian Walkway/ Footpath from Baluwakhani (Vajra Cinema Hall) to Ranipool, Gangtok, East Sikkim including Defect Liability Period of One Year</b></p> <p>Identification no. of this bidding process is- <b>01/SPV/GSCDL/2018 Dt: 26.11.2018</b></p>
ITB 2.1	The Borrower is: GSCDL
ITB 2.1	The name of the Project: <b>Improvement of Pedestrian Walkway/ Footpath from Baluwakhani (Vajra Cinema Hall) to Ranipool, Gangtok, East Sikkim including Defect Liability Period of One Year.</b>
ITB 4.1 (a)	The individuals or firms in a JV is allowed and shall be jointly and severally liable.
ITB 4.1(c)	In support of the requirements for the Joint Venture, a Joint Venture Agreement and a Power of Attorney in favour the JV nominated representative should be submitted.

**B. Bidding Documents**

<b>ITB 7.1</b>	<p>For <u>clarification purposes</u> only, the Employer's address is:</p> <p>Attention: Chief Executive Officer</p> <p>Postal Address: Office of the CEO, GSCDL Office, Sokaythang, Gangtok.</p> <p>ZIP Code: 737101</p> <p>Country: India</p> <p>Telephone: : +91 9733224497</p> <p>Facsimile number: ..</p> <p>Electronic mail address: <a href="mailto:ceosmartcity.gangtok@gmail.com">ceosmartcity.gangtok@gmail.com</a></p> <p>Website : <a href="http://www.gmcsikkim.in">www.gmcsikkim.in</a> and <a href="http://www.smartnet.niua.org">www.smartnet.niua.org</a></p> <p>Requests for clarification should be received by the Employer not later than: 7 days before the closing date of the bid.</p>
<b>ITB 7.4</b>	<p>A Pre-Bid meeting will be held on 04.01.2019 at 14:00 hrs at the Employer's Office.</p>

### C. Preparation of Bids

<p><b>ITB 10.1</b></p> <p><b>ITB 11.2(g)</b></p> <p><b>ITB 11.3(d)</b></p>	<p>The language of the bid is English</p> <p>Bidder shall submit with its Technical Bid the following additional documents: NIL</p> <p>Bidder shall submit with its Price Bid the following additional documents :Rate Analysis of major items</p>
<p><b>ITB 13.1</b></p>	<p>Alternative bids shall not be permitted.</p>
<p><b>ITB 13.2</b></p>	<p>Alternative times for completion shall not be permitted.</p>
<p><b>ITB 13.4</b></p>	<p>Alternative technical solutions shall be permitted for the following parts of the Works: Nil</p>
<p><b>ITB 14</b></p>	<p>The Bidder shall be deemed to have been satisfied himself as to the correctness and sufficiency of the Bid and the rates and prices stated in the Bill of Quantities, all of which shall, except in so far as it is otherwise provided in the contract, cover all his obligations under the contract and all matters and things necessary for the proper execution and completion of the works and the remedying of any defects there in.</p>
<p><b>ITB 15.1</b></p>	<p>The prices shall be quoted by the bidder and shall be paid in: INR</p>
<p><b>ITB 18.1</b></p>	<p>The bid validity period shall be 120 days after the bid submission deadline date.</p>
<p><b>ITB 19.1</b></p>	<p>The Bidder shall furnish a Bid Security for an amount of INR 46.08 Lakhs (2.5% of bid value)</p>
<p><b>ITB 19.3</b></p>	<p>The Bid Security shall be in the form of an unconditional and irrevocable Bank Guarantee only from a Nationalized /Scheduled bank in India. The validity of Bid Security shall be 28 days beyond the original validity period of 120 days or beyond any of extension if requested.</p>
<p><b>ITB 20.1</b></p>	<p>In addition to the original of the bid, the number of copies is: <b>1 (one)</b></p>
<p><b>ITB 20.2</b></p>	<p>The written confirmation of authorization to sign on behalf of the Bidder shall consist of:</p> <p>(a) Power of Attorney from the authorized person to issue from the company.</p>



	<p>(b) In the case of Bids submitted by an existing or intended JV, an Joint Venture Agreement signed by all parties (i) stating that all parties shall be jointly and severally liable, and (ii) nominating a Representative who shall have the authority to conduct all business for and on behalf of any and all the parties of the JV during the bidding process and, in the event the JV is awarded the Contract, during contract execution.</p> <p>(c) All the pages of the bid shall be signed or initialed by a person signing the bid along with the seal.</p>
--	-------------------------------------------------------------------------------------------------------------------------------------------------------------------------------------------------------------------------------------------------------------------------------------------------------------------------------------------------------------------------------------------------------------------------------------------------------------------------------------------------------------------------------------------------------------------------

#### D. Submission and Opening of Bids

<b>ITB 21.1</b>	Bidder shall not have the option of submitting their bids electronically.
<b>ITB 21.1(a)</b>	The Bidder should use the bid documents in original and duplicate issued to him by the Employer for filling and submitting the price bid along with supporting information, if any. He should prepare and submit the technical bid in the formats given in the bid document and submit it separately.
<b>ITB 21.1(b)</b>	Electronic Bid Submission shall be not applicable.
<b>ITB 22.1</b>	<p>For <b><u>bid submission purposes</u></b> only, the Employer's address is:</p> <p>Attention: Chief Executing Officer, GSCDL.</p> <p>Postal Address: Office of the CEO, Sokaythang, Gangtok- 737102, East Sikkim.</p> <p>Floor/Room number:</p> <p>City: Gangtok</p> <p>ZIP Code: 737102</p> <p>Country: India</p> <p><b>The deadline for bid submission is:</b></p> <p>Date: 08.01.2019</p> <p>Time: 14:00 hrs IST</p>
<b>ITB 25.1</b>	<p>The opening of the Technical Bid shall take place at: Office of the CEO, Sokaythang</p> <p>Postal Address: Office of the CEO, Sokaythang, Gangtok- 737102, East Sikkim.</p>

	Floor/Room number:
	City: Gangtok
	Country: India
	Date 08.01.2019
	Time: 14:30 hrs IST

**E. Evaluation and Comparison of Bids**

<b>ITB 34.1</b>	The currency that shall be used for bid evaluation and comparison purposes to convert all bid prices expressed in various currencies into a single currency is: INR
<b>ITB 35</b>	A margin of preference shall not apply
<b>ITB 43.1</b>	Performance Security shall be from a nationalized bank/scheduled bank situated in India and shall be valid for a period of 28 days beyond the DLP (defects liability period)
<b>ITB 43.3</b>	Not applicable

## Section 3 - Evaluation and Qualification Criteria

### 1. Evaluation

In addition to the criteria listed in ITB 37.2 (a) – (f) the following criteria shall apply:

#### **1.1 Adequacy of Technical Proposal**

Evaluation of the Bidder's Technical Proposal will include an assessment of the Bidder's technical capacity to mobilize key equipment and personnel for the contract consistent with its proposal regarding work methods, scheduling, and material sourcing in sufficient detail and fully in accordance with the requirements stipulated in Section 6 (Works Requirements).

#### **1.2 Multiple Contracts**

Pursuant to ITB 36.4, if Works are grouped in multiple contracts, evaluation will be as follows: Not applicable.

#### **1.3 Completion Time**

An alternative Completion Time, if permitted under ITB 13.2, will be evaluated as follows:

Not applicable

#### **1.4 Alternative Technical Solutions**

Alternative technical solutions, if permitted under ITB 13.4, will be evaluated as follows:

Not applicable

#### **1.5 Margin of Preference (Applicable for ICB only):**

Not applicable

#### **1.6 Quantifiable Nonconformities, Errors and Omissions**

The evaluated cost of quantifiable nonconformities, errors and/or omissions are determined as follows:

"Pursuant to Sub-Clause 31.3 of Section 1: Instructions to Bidders, the cost of all quantifiable nonconformities, errors, or omissions in a Bidder's Bid Proposal shall be evaluated. The Employer shall make its assessment of the cost of any quantifiable nonmaterial nonconformities, errors, or omissions for the purpose of ensuring fair comparison of Bids, and for this purpose, the Employer shall base its assessment on the highest price quoted for the same item(s) or component(s) by the other responsive Bidders."

## 2. Qualification

### 2.1 Eligibility

Criteria	Compliance Requirements			Documents	
Requirement	Single Entity	Joint Venture			Submission Requirements
		All Partners Combined	Each Partner	One Partner	

#### 2.1.1 Nationality

Nationality in accordance with ITB Sub-Clause 4.2.	must meet requirement	existing or intended JV must meet requirement	must meet requirement	not applicable	Forms ELI -1; ELI -2 with attachments
----------------------------------------------------	-----------------------	-----------------------------------------------	-----------------------	----------------	---------------------------------------------

#### 2.1.2 Conflict of Interest

No conflicts of interest in accordance with ITB Sub-Clause 4.3.	must meet requirement	existing or intended JV must meet requirement	must meet requirement	not applicable	Letter of Technical Bid
-----------------------------------------------------------------	-----------------------	-----------------------------------------------	-----------------------	----------------	-------------------------

#### 2.1.3 GSCDL Eligibility

Not having been declared ineligible by GSCDL & any other agencies in India, as described in ITB Sub-Clause 4.4.	must meet requirement	existing or intended JV must meet requirement	must meet requirement	not applicable	Letter of Technical Bid
-----------------------------------------------------------------------------------------------------------------	-----------------------	-----------------------------------------------	-----------------------	----------------	-------------------------

#### 2.1.4 Government-owned Entity

Bidder required to meet conditions of ITB Clauses & Sub-Clause 4.5.	must meet requirement	existing or intended JV must meet requirement	must meet requirement	not applicable	Forms ELI -1, ELI - 2 with attachments
---------------------------------------------------------------------	-----------------------	-----------------------------------------------	-----------------------	----------------	----------------------------------------

**2.1.5 National Eligibility**

Not having been declared ineligible based on an Employer's country law, as described in ITB's Clauses & Sub-Clauses.	must meet requirement	existing or intended JV must meet requirement	must meet requirement	not applicable	Letter of Technical Bid
----------------------------------------------------------------------------------------------------------------------	-----------------------	-----------------------------------------------	-----------------------	----------------	-------------------------

**2.2 Pending Litigation**

Criteria	Compliance Requirements			Documents	
Requirement	Single Entity	Joint Venture			Submission Requirements
		All Partners Combined	Each Partner	One Partner	

**2.2.1 Pending Litigation**

All pending litigation shall be treated as resolved against the Bidder and so shall in total not represent more than 80 percent of the Bidder's net worth.	must meet requirement by itself or as partner to past or existing JV	not applicable	must meet requirement by itself or as partner to past or existing JV	not applicable	Form LIT - 1
------------------------------------------------------------------------------------------------------------------------------------------------------------	----------------------------------------------------------------------	----------------	----------------------------------------------------------------------	----------------	--------------

**2.3 Financial Situation**

Criteria	Compliance Requirements			Documents	
Requirement	Single Entity	Joint Venture			Submission Requirements
		All Partners Combined	Each Partner	One Partner	

### 2.3.1 Historical Financial Performance

Submission of audited balance sheets and income statements or, if not required by the law of the Bidder's country, other financial statements acceptable to the Employer, for the last 3 years to demonstrate the current soundness of the Bidder financial position. As a minimum, a Bidder's net worth calculated as the difference between total assets and total liabilities should be positive.	must meet requirement	not applicable	must meet requirement	not applicable	Form FIN - 1 with attachments
------------------------------------------------------------------------------------------------------------------------------------------------------------------------------------------------------------------------------------------------------------------------------------------------------------------------------------------------------------------------------------------------------	-----------------------	----------------	-----------------------	----------------	-------------------------------

### 2.3.2 Average Annual Construction Turnover

Minimum average annual construction turnover of <b>INR 6 Crores</b> , calculated as total certified payments received for contracts in progress or completed, within the last 3 years.	must meet requirement 100%	must meet requirement 100%	must meet 25% of the requirement	must meet 40% of the requirement	Form FIN - 2
----------------------------------------------------------------------------------------------------------------------------------------------------------------------------------------	-------------------------------	-------------------------------	----------------------------------	----------------------------------	--------------

**Note: Financial Turnover and cost of completed works of previous years shall be given weightage of 5% per year based on rupee value to bring them to a current price level.**

### 2.3.3 Financial Resources

Using the relevant Forms FIN -3 and FIN - 4 in Section 4 (Bidding Forms) the Bidder must demonstrate access to, or availability of, financial resources such as liquid assets, unencumbered real assets, lines of credit, and other financial means, other than any contractual advance payments, to meet the financial requirements of the contract in the amount of his Bid. As a minimum the Bidder must show that his resources, in terms of at least his latest year's working capital and lines of credit, will be adequate to cover his Bid Price and current work commitments. This will be calculated as follows:

$(5 \times \text{working capital} + \text{letter of credit}) - 40\% (\text{current contract commitments}) \text{ should be } \geq \text{the bid price.}$

### 2.4 Experience

Criteria	Compliance Requirements		Documents
Requirement	Single Entity	Joint Venture	

		All Partners Combined	Each Partner	One Partner	Submission Requirements
--	--	--------------------------	-----------------	----------------	----------------------------

**2.4.1 General Construction Experience**

Experience under construction contracts in the role of contractor, subcontractor, or management contractor for at least the last 5 years prior to the applications submission deadline.	must meet requirement	not applicable	must meet requirement	not applicable	Form EXP -1
-----------------------------------------------------------------------------------------------------------------------------------------------------------------------------------------	-----------------------	----------------	-----------------------	----------------	-------------

**2.4.2 Specific Construction Experience**

(a) Contracts of Similar Size and Nature

Participation as contractor, management contractor, subcontractor, within the last 5 years, 2 works of Similar nature each with a value of <b>INR 10 crores</b> that has been successfully or is substantially completed and that are similar to the proposed works (including earthwork, PCC, RCC, steel reinforcement, tile and paver block laying, kerb stones, bollard works, Steel	must meet requirement	must meet requirement	not applicable	not applicable	Form EXP -2(a)
-----------------------------------------------------------------------------------------------------------------------------------------------------------------------------------------------------------------------------------------------------------------------------------------------------------------------------------------------------------------------------------------	-----------------------	-----------------------	----------------	----------------	----------------

railing, utility ducting, road works, retaining structures, other utility works, etc. The similarity shall be based on the physical size, complexity, methods, technology or other characteristics as described in Section 6, Works Requirements.					
---------------------------------------------------------------------------------------------------------------------------------------------------------------------------------------------------------------------------------------------------	--	--	--	--	--

**Note: The bidder must fulfil the aggregate of the specific experience for qualifying in multiple lots**

**2.4.3. Eligible class of Contractor:**

Class IA Contractor registered under unified registration system in SK PWD with a valid UIN or Equivalent Registration in any state Govt. Dept. Central Govt. Dept., other Govt. Dept./ undertaking of state /Central Govt.

**2.5 Personnel**

The Bidder must demonstrate that it has the personnel for the key positions that meet the following requirements:

No.	Position	Total Work Experience [years]	Experience In Similar Works [years]
1	Project Manager – 1 no.	B.E. Civil Engineering with 20 years’ experience in relevant field	B.E. Civil Engineering with 2 years’ experience in relevant field
2	Civil Engineer-2 no.	B.E. Civil Engineering with 10 years’ experience in relevant field	B.E. Civil Engineering with 2 years’ experience in relevant field
3	Civil Engineer-3 no	8 years’ experience in relevant field	



4	Site supervisors-10 no.	Diploma in Civil Engineer with 5 years' experience in relevant field; or B.E. Civil Engineering with 2 years' experience in relevant field	Diploma in Civil Engineer with 2 years' experience in relevant field; or B.E. Civil Engineering with 1 years' experience in relevant field
---	-------------------------	--------------------------------------------------------------------------------------------------------------------------------------------	--------------------------------------------------------------------------------------------------------------------------------------------

**Note: The bidder shall furnish separate list of key personnel**

The Bidder shall provide details of the proposed personnel and their experience records in the relevant Information Forms included in Section 4 (Bidding Forms).

### **2.6 Equipment**

The Bidder must demonstrate that it has the key equipment listed hereafter:

<b>No.</b>	<b>Equipment Type and Characteristics</b>	<b>Min. Number Required</b>
1	Reversible Concrete Drum Mixer 21/14	4
2	Mini Batching Plant of Minimum Capacity of 8 Cum/Hour	1
3	Concrete Pump	1
4	Laboratory for testing fineness, consistency, setting time compressive & tensile strength of cement compressive & flexural strength of Cement concrete and proof stress, elongation, tensile strength, bending & re-bending of reinforcement steel. Fully equipped laboratory for testing of general materials located at project site or at authority approved nearby place.	1

The Bidder shall provide further details of proposed items of equipment using the relevant Form in Section 4 (Bidding Forms)

## Section 4 - Bidding Forms

### LETTER OF TECHNICAL BID

The Bidder must accomplish the Letter of Bid in its letterhead clearly showing the Bidder's complete name and address.

Date: .....

Bid No.: .....

Invitation for Bid No.: .....

To: CEO, GSCDL, Sokaythang, Gangtok.

We, the undersigned, declare that:

- (a) We have examined and have no reservations to the Bidding Documents, including Addenda No. \_\_\_\_\_;
- (b) We offer to execute in conformity with the Bidding Documents the following Works: **Improvement of Pedestrian Walkway/ Footpath 12.00 km (approx.) from Baluwakhani (Vajra Cinema Hall) to Ranipool, Gangtok, East Sikkim including Defect Liability Period of One Year**
- (c) Our bid shall be valid for a period of 120 days from the date fixed for the bid submission deadline in accordance with the Bidding Documents, and it shall remain binding upon us and may be accepted at any time before the expiration of that period;
- (d) If our Bid is accepted, we commit to obtain a Performance Security in the amount of 5 percent of the contract Price for the due performance of Contract.
- (e) Our firm, including any subcontractors or suppliers for any part of the Contract, have Indian nationalities;
- (f) We, including any subcontractors or suppliers for any part of the contract, do not have any conflict of interest in accordance with ITB<sup>1</sup>;
- (g) We are not participating, as a Bidder or as a subcontractor, in more than one bid in this bidding process in accordance with ITB,

---

<sup>1</sup> Include if price adjustment provisions apply in the Contract in accordance with PCC Sub-Clause 44.1.

- (h) Our firm, its affiliates or subsidiaries, including any Subcontractors or Suppliers for any part of the contract, has not been declared ineligible by the Employer & other agencies, under the Employer's country laws;
- (i) We understand that this Bid, together with your written acceptance thereof included in your notification of award, shall constitute a binding contract between us, until a formal Contract is prepared & executed.
- (j) We understand that you are not bound to accept the lowest evaluated bid or any other bid that you may receive.
- (k) We agree to permit GSCDL or its representative to inspect our accounts and records and other documents relating to the bid submission and to have them audited by auditors appointed by the GSCDL<sup>2</sup>.
- (l) The total price of our bid, excluding the discounts is INR ..... & ..... %  
(above / below)

Name .....

In the capacity of .....

Signed

.....  
 .....

Duly authorized to sign the Bid for and on behalf of .....

Date

.....  
 .....

---

<sup>2</sup> Use one of the two options as appropriate.

## LETTER OF PRICE BID

Date: .....

Bid No.: .....

Invitation for Bid No.: .....

To: CEO, GSCDL, Sokaythang, Gangtok.

We, the undersigned, declare that:

(a) We have examined and have no reservations to the Bidding Documents, including Addenda issued in accordance with Instructions to Bidders (ITB) 8;

(b) We offer to execute in conformity with the Bidding Documents the following Works:

**Improvement of Pedestrian Walkway/ Footpath 12.00 km (approx.) from Baluwakhani (Vajra Cinema Hall) to Ranipool, Gangtok, East Sikkim including Defect Liability Period of One Year**

(c) The total price of our Bid, excluding any discounts offered in item (d) below is: ..... % (above / below)

(d) The discounts offered and the methodology for their application are: INR .....

(e) Our Bid shall be valid for a period of 120 days from the date fixed for the bid submission deadline in accordance with the Bidding Documents, and it shall remain binding upon us and may be accepted at any time before the expiration of that period;

(f) If our Bid is accepted, we commit to obtain a performance security in accordance with the Bidding Documents;

(g) We have paid, or will pay the following commissions, gratuities, or fees with respect to the bidding process or execution of the Contract: \*\*

Name of Recipient	Address	Reason	Amount
.....	.....	.....	.....
.....	.....	.....	.....

(h) We understand that this bid, together with your written acceptance thereof included in your notification of award, shall constitute a binding contract between us, until a formal contract is prepared and executed; and

- (i) We understand that you are not bound to accept the lowest evaluated bid or any other bid that you may receive.
- (j) We agree to permit GSCDL or its representative to inspect our accounts and records and other documents relating to the bid submission and to have them audited by auditors appointed by the GSCDL.
- (k) If awarded the contract, the person named below shall act as Contractor's Representative.

Name .....

In the capacity of .....

Signed .....  
.....

Duly authorized to sign the Bid for and on behalf of .....

Date  
.....  
.....

**\*\*If none has been paid or is to be paid, indicate "none"**

**BID SECURITY**

**Bank Guarantee**

Bank's Name, and Address of Issuing Branch or Office

**Beneficiary:**

**Date:** .....

**Bid Security No.:** .....

We have been informed that . . . . . **name of the Bidder**. . . . . (hereinafter called "the Bidder") has submitted to you its bid dated . . . . . (Hereinafter called "the Bid") for the execution of . . . . . **name of Contract** . . . . . under Invitation for Bids No. . . . . ("the IFB").

Furthermore, we understand that, according to your conditions, bids must be supported by a bid guarantee.

At the request of the Bidder, we . . . . . **name of Bank**. . . . . hereby irrevocably undertake to pay you any sum or sums not exceeding in total an amount of . . . . . amount in figures . . . . . (**amount in words** . . . . . ) upon receipt by us of your first demand in writing accompanied by a written statement stating that the Bidder is in breach of its obligation(s) under the bid conditions, because the Bidder:

- (a) has withdrawn its Bid during the period of bid validity specified by the Bidder in the Form of Bid; or
- (b) does not accept the correction of errors in accordance with the Instructions to Bidders (hereinafter "the ITB"); or
- (c) having been notified of the acceptance of its Bid by the Employer during the period of bid validity, (i) fails or refuses to execute the Contract Agreement, or (ii) fails or refuses to furnish the performance security, in accordance with the ITB.

This guarantee will expire: (a) if the Bidder is the successful Bidder, upon our receipt of copies of the Contract Agreement signed by the Bidder and the Performance Security issued to you upon the instruction of the Bidder; and (b) if the Bidder is not the successful Bidder, upon the earlier of (i) our receipt of a copy your notification to the Bidder of the name of the successful Bidder; or (ii) twenty-eight days after the expiration of the Bidder's bid.

Consequently, any demand for payment under this guarantee must be received by us at the office on or before that date.

This guarantee is subject to the Uniform Rules for Demand Guarantees, ICC Publication No. 458.

..... **Bank's seal and authorized signature(s)** .....

## TECHNICAL PROPOSAL

*Form PER – 1: Proposed Personnel*

Bidders should provide the names of suitably qualified personnel to meet the specified requirements for each of the positions listed in Section 3 (Evaluation and Qualification Criteria). The data on their experience should be supplied using the Form below for each candidate.

1	Title of position
	Name
2	Title of position*
	Name
3	Title of position*
	Name
4	Title of position*
	Name
5	Title of position*
	Name

**\*As listed in section 3 (Evaluation and Qualification criteria)**

Form PER – 2: Resume of Proposed Personnel

The Bidder shall provide all the information requested below. Fields with asterisk (\*) shall be used for evaluation.

Position*		
Personnel information	Name	Date of birth
	Professional qualifications	
Present employment	Name of employer	
	Address of employer	
	Telephone	Contact (manager / personnel officer)
	Fax	E-mail
	Job title	Years with present employer



Summarize professional experience in reverse chronological order. Indicate particular technical and managerial experience relevant to the project.

<b>From*</b>	<b>To*</b>	<b>Company, Project, Position and Relevant Technical and Management Experience*</b>

*Equipment*

The Bidder shall provide adequate information to demonstrate clearly that it has the capability to meet the requirements for the key equipment listed in Section 3 (Evaluation and Qualification Criteria). A separate Form shall be prepared for each item of equipment listed, or for alternative equipment proposed by the Bidder. The Bidder shall provide all the information requested below, to the extent possible. Fields with asterisk (\*) shall be used for evaluation.

Form- E Q I

Type of Equipment*		
Equipment Information	Name of manufacturer	Model and power rating
	Capacity*	Year of manufactured
Current Status	Current location	
	Details of current commitments	
Source	Indicate source of the equipment <input type="checkbox"/> Owned <input type="checkbox"/> Rented <input type="checkbox"/> Leased <input type="checkbox"/> Specially manufactured	

The following information shall be provided only for equipment not owned by the Bidder.

Form-EQ-2

Owner	Name of owner	
	Address of owner	
	Telephone	Contact name and title
	Fax	Telex
Agreements	Details of rental / lease / manufactured agreements specific to the project	

## BIDDER'S QUALIFICATION

To establish its qualifications to perform the contract in accordance with Section 3 (Evaluation and Qualification Criteria) the Bidder shall provide the information requested in the corresponding Information Sheets included hereunder

Form ELL – 1: Bidder's Information Sheet

Bidder's Information	
Bidder's legal name	
In case of JV, legal name of each partner	
Bidder's country of constitution	
Bidder's year of constitution	
Bidder's legal address in country of constitution	
Bidder's authorized representative  (name, address, telephone numbers, fax numbers, e-mail address)	

Attached are copies of the following original documents.

1. In case of single entity, articles of incorporation or constitution of the legal entity named above, in accordance with ITB 4.1 and 4.2.
2. Authorization to represent the firm or JV named in above, in accordance with ITB 20.2.
3. In case of JV, JV agreement, in accordance with ITB 4.1.
4. In case of a government-owned entity, any additional documents not covered under 1 above required to comply with ITB 4.5.

Form ELI - 2: JV Information Sheet

Each member of a JV must fill in this form

JV / Specialist Subcontractor Information	
Bidder's legal name	
JV Partner's legal name	
JV Partner's country of constitution	
JV Partner's year of constitution	
JV Partner's legal address in country of constitution	
JV Partner's authorized representative information  (name, address, telephone numbers, fax numbers, e-mail address)	

Attached are copies of the following original documents.

1. Articles of incorporation or constitution of the legal entity named above, in accordance with ITB 4.1 and 4.2.
2. Authorization to represent the firm named above, in accordance with ITB 20.2.
3. In the case of government-owned entity, documents establishing legal and financial autonomy and compliance with commercial law, in accordance with ITB 4.5.

Form LIT - 1: Pending Litigation

Each Bidder or member of a JV must fill in this form

Pending Litigation			
No pending litigation in accordance with Criteria 2.2 of Section 3 (Evaluation and Qualification Criteria)			
Pending litigation in accordance with Criteria 2.2 of Section 3 (Evaluation and Qualification Criteria)			
Year	Matter in Dispute	Value of Pending Claim in INR	Value of Pending Claim as a Percentage of Net Worth



Form FIN - 1: Financial Situation

Each Bidder or member of a JV must fill in this form

Financial Data for Previous 5 Years [INR Equivalent]				
Year 1:	Year 2:	Year 3:	Year 4:	Year 5:

Information from Balance Sheet

Total Assets			
Total Liabilities			
Net Worth			
Current Assets			
Current Liabilities			

Information from Income Statement

Total Revenues			
Profits Before Taxes			
Profits After Taxes			

Attached are copies of financial statements (balance sheets including all related notes, and income statements) for the last five years, as indicated above, complying with the following conditions.

- All such documents reflect the financial situation of the Bidder or partner to a JV, and not sister or parent companies.
- Historic financial statements must be audited by a certified accountant.
- Historic financial statements must be complete, including all notes to the financial statements.
- Historic financial statements must correspond to accounting periods already completed and audited (no statements for partial periods shall be requested or accepted).

To:

Gentlemen:

1. We have seen the Section 6A: Standard Specifications and we have studied and understood all the Clauses of this Section. We accordingly offer to design, execute and complete the said Works and remedy any defects therein, fit for purpose in conformity with the relevant Clauses of this Section.
2. We further undertake to accept that these form a part of our bid and we agree to sign these at the time when the contract agreement is executed.

Dated this \_\_\_\_\_ day of \_\_\_\_\_ 2011\_\_.

Signed and Sealed by : \_\_\_\_\_

In the Capacity of : \_\_\_\_\_

Name and Address of Bidder : \_\_\_\_\_

(affix company seal)

## Section 5 - SCHEDULES- BILL OF QUANTITY

Sl. No	Ref. SOR-2012/ Rate analysis	Particulars	Unit	Rate (in INR)	Quantity	Amount (in INR)
	SOR Items					
1	2.1/P-1/SOR Page-7	Clearing jungle including uprooting of rank vegetation, grass, brush wood, trees and saplings of girth upto 30 cm measured at a height of 1 m above ground level and removal of rubbish upto a distance of 50 m outside the periphery of the area cleared.	Sqm		18143.70	
2	2.1/P-1/SOR Page-74	Cutting of Trees, including Cutting of Trunks, Branches and Removal (Cutting of trees, including cutting of trunks, branches and removal of stumps, roots, stacking of serviceable material with all lifts and up to a lead of 50 mtrs and earth filling in the depression/ pit.)				
		(i) Girth from 300 mm to 600 mm each	each		2.00	
		(ii) Girth from 600 mm to 900 mm each	each		4.00	
		(iii) Girth from 900 mm to 1800 mm each	each		4.00	
		(iv) Girth above 1800 mm	each			
3	2.4/P-1/SOR Page-75	Dismantling of Structures (Dismantling of existing structures like culverts, bridges, retaining walls and other structure comprising of masonry, cement concrete, wood work, steel work, including T&P and scaffolding wherever necessary, sorting				

SI. No	Ref. SOR-2012/ Rate analysis	Particulars	Unit	Rate (in INR)	Quantity	Amount (in INR)
		the dismantled material, disposal of unserviceable material and stacking the serviceable material with all lifts and lead of 1000 metres). Payment shall be made to the contractor as per actual quantity executed.				
	(i)	Lime /Cement Concrete				
	I	Manual Means				
	A	Lime Concrete, cement concrete grade M-10 and below				
	B	Cement Concrete Grade M-15 & M-20				
	C	Pre-stressed / Reinforced cement concrete grade M-20 & above				
	II	By Mechanical Means				
	A	Cement Concrete Grade M-15 & M-20	Cum			
	ii	Dismantling Brick / Tile work				
	B	In cement mortar	Cum			
4	SOR 2012, I.N. 2.7 Page 76	Dismantling MS Railing (Dismantling guard rails by manual/mechanical means and stacking of dismantled material at proper position as directed by engineer-in-charge with all lifts and up to a lead of 1000 metres, stacking serviceable materials and unserviceable materials	Metre		12928.50	

Sl. No	Ref. SOR-2012/ Rate analysis	Particulars	Unit	Rate (in INR)	Quantity	Amount (in INR)
		separately.) Payment shall be made to the contractor as per actual quantity executed.				
5	SOR 2012, I.N. 2.8 Page 76	Dismantling Kerb Stone (Dismantling kerb stone by manual means and disposal of dismantled material with all lifts and up to a lead of 1000 metre) Payment shall be made to the contractor as per actual quantity executed.	Metre		1200.00	
6	SOR 2012, I.N. 2.14 Page 77	Removal of Telephone / Electric Poles and Lines (Removal of telephone / Electric poles including excavation and dismantling of foundation concrete and lines under the supervision of concerned department, disposal with all lifts and up to a lead of 1000 metres and stacking the serviceable and unserviceable material separately) Payment shall be made to the contractor as per actual quantity executed.	Each		500.00	
7	SOR 2012, I.N. 3.1 a Page 77	Excavation in soil in hilly area by mechanical means including cutting and trimming of side slopes and disposing of excavated earth with all lifts and lead upto 1000 meters. Payment shall be made to the contractor as per actual quantity executed.	Cum		200.00	
8	SOR 2012, I.N. 3.2 a Page 77	Excavation in soil in hilly area by manual means including cutting and trimming of side slopes and disposing of	Cum		15469.32	

Sl. No	Ref. SOR-2012/ Rate analysis	Particulars	Unit	Rate (in INR)	Quantity	Amount (in INR)
		excavated earth with all lifts and lead upto 50 meters.				
9	SOR 2012, I.N. 3.3 a Page 78	Excavation in hilly area in ordinary rock not requiring blasting by mechanical means including cutting and trimming of slopes and disposal of cut material with all lift and lead upto 1000 meters. Payment shall be made to the contractor as per actual quantity executed.	Cum		200.00	
10	SOR 2012, I.N. 3.2 a Page 78	Excavation in hilly area in ordinary rock not requiring blasting by Manual means including cutting and trimming of slopes and disposal of cut material with all lift and lead upto 50 meters. Payment shall be made to the contractor as per actual quantity executed.	Cum		4670.19	
11	SOR 2012, I.N. 3.10 Page 79	Scarifying Existing Granular Surface to a Depth of 50 mm by Manual Means (Scarifying the existing granular road surface to a depth of 50 mm and disposal of scarified material within all lifts and leads upto 1000 metres. ) Payment shall be made to the contractor as per actual quantity executed.	Sqm		250.00	
12	SOR 2012, I.N. 3.15 Page 80	Compacting Original Ground				
	Case I	Compacting original ground supporting subgrade (Loosening of the ground upto a level of 500 mm below the	Cum		2128.86	

Sl. No	Ref. SOR-2012/ Rate analysis	Particulars	Unit	Rate (in INR)	Quantity	Amount (in INR)
		subgrade level, watered, graded and compacted in layers to meet requirement of table 300-2 for subgrade construction.)				
13	SOR 2012, I.N. 4.19 Page 86	Stone Soling for road works: Providing & laying hand packed stone soling of specified thickness with clean hard selected stones including hammer dressing of stone for laying as per required level and camber including packing with broken stones obtained from hammer dressing to fill the voids to give uniform surface as directed by the Engineer-in-Charge all complete but excluding carriage and consolidation using:				
	A	Manual means	Cum		1197.48	
	B	carriage	Cum		1197.48	
14	SOR 2012, I.N. 4.20 Page 86	Filling for road works Filling by supplying filling materials from outside in road works, in layers not exceeding 20 cm in depth excluding carriage of materials and including consolidation of each layer by ramming, watering etc all complete by manual/mechanical means.	Cum		350.00	
15	SOR 2012, I.N. 5.2 Page 9	Filling with available excavated earth in trenches, plinth and side of foundation in building works with layers not exceeding 20cm in depth including consolidation of each layer by ramming, watering etc, all complete.	Cum		500.00	



Sl. No	Ref. SOR-2012/ Rate analysis	Particulars	Unit	Rate (in INR)	Quantity	Amount (in INR)
16	SOR 2012, I.N. 12.3 Page 114	Sand Filling in Foundation Trenches as per Drawing & Technical Specification	Cum		1471.45	
17	SOR 2012, I.N. 12.8 Page 113	Plain/Reinforced cement concrete in sub-structure complete as per drawing and technical specifications				
	A	PCC Grade M15	Cum		2261.91	
	B	PCC Grade M20	Cum		226.19	
	D	PCC Grade M25				
		Case I: Using concrete mixer	Cum		29.70	
18	SOR 2012, I.N. 18.2 Page 34	Supplying, bending and placing in position tor- steel reinforcement in all R.C.C works including cost of binding wires, all complete.	Quintal		161.89	
19	SOR 2012, I.N. 14.2 Page 133	Providing, fixing & removing form work for casting R.C.C items as indicated below: with locally available timber)				
	14.2.3	Wall	Sqm		191.40	
20	SOR 2012, I.N. 8.1 Page 11	Providing and Laying in position specified grade of reinforced cement concrete excluding the cost of form work, finishing and reinforcements.				
	8.1.1	1:1:2 Mix (1cement, 2 coarse sand 2 graded stone aggregate 20mm and down nominal gauge)	Cum		30.80	
	8.1.2	1:1.5:3 Mix (1cement, 1.5 coarse sand 3 graded stone	Cum		107.81	

Sl. No	Ref. SOR-2012/ Rate analysis	Particulars	Unit	Rate (in INR)	Quantity	Amount (in INR)
		aggregate 20mm and down nominal gauge)				
21	SOR 2012, I.N. 14.11 Page 138	Reinforced cement concrete approach slab including reinforcement and formwork complete as per drawing and Technical specification	Cum			
22	SOR 2012, I.N. 13.1 Page 130	Brick masonry work in 1:3 in sub-structure complete excluding pointing and plastering, as per drawing and technical specifications	Cum		200.00	
23	SOR 2012, I.N. 13.2 Page 131	Pointing with cement mortar (1:3 ) on brick work in substructure as per Technical specifications	Sqm		2447.53	
24	SOR 2012, I.N. 9.3 Page 12	Providing and Laying 20 mm thick cement plaster of specified mix in single coat including finishing even and smooth and curing etc all complete.				
	9.3.2	1:4 mix.	Sqm		100.00	
25	SOR 2012, I.N. 8.1 Page 96	Cast in Situ Cement Concrete M20 kerb (Construction of cement concrete kerb with top and bottom width 115 and 165 mm respectively, 250 mm high in M 20 grade PCC on M-10 grade foundation 150 mm thick, foundation having 50 mm projection beyond kerb stone, kerb stone laid with kerb laying machine, foundation concrete laid manually, all complete as per clause 408)				
	A	Using Concrete Mixer	Metre		1000.00	
	B	Using Concrete Batching and Mixing Plant	Metre			

Sl. No	Ref. SOR-2012/ Rate analysis	Particulars	Unit	Rate (in INR)	Quantity	Amount (in INR)
26	SOR 2012, I.N. 8.8 Page 97	Painting Two Coats on New Concrete Surfaces: (Painting two coats after filling the surface with synthetic enamel paint in all shades on new plastered concrete surfaces) As directed by Engineer-in-Charge.	Sqm		4475.45	
27	SOR 2012, I.N. 11.32 Page 19	Providing and Laying Chequers tiles in on flooring over 12mm thick cement plaster (1cement, 3coarsed sand) 1:3 bare and jointed with white cement slurry.	Sqm		111.38	
28	SOR 2012, I.N. 16.21 Page 144	Repair of steel Railing (Repair of steel railing to bring it to the original shape)	Metre		2585.70	
29	SOR 2012, I.N. 22.1.2 Page 38	PRIMER: Providing and applying priming coat with ready mixed Red oxide, Zinc chromate primer on steel / galvanized Iron steel works including preparation of the surface complete.	Sqm		14559.95	
30	SOR 2012, I.N. 8.9 Page 97	Painting on Steel Surfaces (Providing and applying two coats of ready mix paint of approved brand on steel surface after thorough cleaning of surface to give an even shade)	Sqm		14559.95	
31	8.4/p-96/SOR	Retro- reflectorized Traffic signs (Providing and fixing of retro- reflectorized cautionary, mandatory and informatory sign as per IRC :67 made of encapsulated lens type reflective sheeting vide clause 801.3, fixed over aluminum sheeting, 1.5 mm thick				

Sl. No	Ref. SOR-2012/ Rate analysis	Particulars	Unit	Rate (in INR)	Quantity	Amount (in INR)
		supported on a mild steel angle iron post 75 mm x 75 mm x 6 mm firmly fixed to the ground by means of properly designed foundation with M15 grade cement concrete 45 cm x 45 cm x 60 cm, 60 cm below ground level as per approved drawing)				
		90 cm equilateral triangle	each		5.00	
		60 cm equilateral triangle	each		15.00	
		60 cm circular	each		12.00	
		80 mm x 60 mm rectangular	each		25.00	
		60 cm x 45 cm rectangular	each		15.00	
		60 cm x 60 cm square	each		15.00	
		90 cm high octagon	each			
32	SOR 2012, I.N. 8.27 Page 101	Street Lighting (Providing and erecting street light mounted on a steel circular hollow pole of standard specifications for street lighting, 9 m high spaced 40 m apart, 1.8 m overhang on one side if fixed on the footpath, fitted with sodium vapour lamp and fixed firmly in concrete foundation.) including design of foundations and required drawings.				
	(ii)	For fixing in Footpath	Each		404.00	
33	SOR 2012, I.N. 16.19 Page 144	Repair of crash barrier (Repair of concrete crash barrier with cement concrete of M-30 grade by cutting and trimming the damaged portion to a regular shape, cleaning the area to be repaired thoroughly,	Metre		24.00	

Sl. No	Ref. SOR-2012/ Rate analysis	Particulars	Unit	Rate (in INR)	Quantity	Amount (in INR)
		applying cement concrete after erection of proper form work.)				
34	SOR 2012, I.N. 23.3 Page 42	Providing, Fitting and fixing GI pipe of medium class, (excluding trenching, refilling, compacting and the cost of fittings) all complete				
	23.3.1	15 mm dia G I pipe	Rmt		900.00	
	23.3.2	20mm dia G I pipe	Rmt		900.00	
	23.3.3	25mm dia G I pipe	Rmt		900.00	
		Extra 20 % for cost of fittings				
35	SOR 2012, I.N. 25 Page 48	HEAD LOAD AND CARRIAGES:				
		Stock materials:				
	25.1	Head load for a distance beyond 30 m and within 100m distance.	qtls		7196.80	
	25.3	Head load for a distance beyond 100 m for every additional 1000m	qtls			
		Non-Stock materials:				
	25.2	Head load for a distance beyond 30 m and within 100 m distance	Cum		385.44	
	25.4	Head load for a distance beyond 100 m for every additional 1000m	Cum			
		Loading and Unloading:				

SI. No	Ref. SOR-2012/ Rate analysis	Particulars	Unit	Rate (in INR)	Quantity	Amount (in INR)
	25.5	Stone Boulder/Stone aggregates/Sand/Kanker/Moorum	Cum		2849.88	
	25.6	Boulders by Manual Means	Cum			
	25.7	Cement or Steel by Manual Means and Stacking.	MT		7196.80	
	25.8	Cost of Haulage Excluding Loading and Unloading:				
	25.8.1	Surfaced Road	MT/Km		1205081.01	
	25.8.2	Un-surfaced Graveled Road	MT/Km			
	25.8.3	Katcha Track and Track in River Bed/Nallah Bed	MT/Km			
36	SOR 2012, Basic rate Page 48	Providing Labour/Helper as directed.	Day		2000.00	
		Total for SOR Items (I)	I			
		Add GST @10% on (I)				
		<b>SOR Items amount (A)</b>	<b>A</b>			
	<b>Non-SOR Items</b>					
37		Providing and laying at or near ground level factory made kerb stone of M-25 grade cement concrete in position to the required line, level and curvature, jointed with cement mortar 1:3 (1 cement: 3 coarse	Cum		1150.05	

Sl. No	Ref. SOR-2012/ Rate analysis	Particulars	Unit	Rate (in INR)	Quantity	Amount (in INR)
		sand), including making joints with or without grooves (thickness of joints except at sharp curve shall not to more than 5mm), including making drainage opening wherever required complete etc. as per direction of Engineer-in-charge (length of finished kerb edging shall be measured for payment). (Precast C.C. kerb stone shall be approved by Engineer-in-charge).				
38		Providing, fitting and fixing mild steel railing complete as per drawing and Technical Specification	Kg		41119.37	
39		Taking out existing CC interlocking paver blocks from footpath/ central verge, including removal of rubbish etc., disposal of unserviceable material to the dumping ground, for which payment shall be made separately and stacking of serviceable material within 50 metre lead as per direction of Engineer-in-Charge.	Sqm		16615.73	
40		Laying old cement concrete interlocking paver blocks of any design/ shape laid in required line, level, curvature, colour and pattern over and including 50 mm thick compacted bed of coarse sand, filling the joints with fine sand etc. all complete as per the direction of Engineer-in-charge. (Old CC paver blocks shall be supplied by the department free of cost).	Sqm		7047.65	

Sl. No	Ref. SOR-2012/ Rate analysis	Particulars	Unit	Rate (in INR)	Quantity	Amount (in INR)
41		Providing and laying 60 mm thick factory made cement concrete interlocking paver block of M-30 grade made by block making machine with strong vibratory compaction, of approved size, design & shape, laid in required colour and pattern over and including 50mm thick compacted bed of coarse sand, filling the joints with line sand etc. all complete as per the direction of Engineer-in-charge.	Sqm		15881.51	
42		Providing and laying factory made chamfered edge Cement Concrete paver blocks in footpath, parks, lawns, drive ways or light traffic parking etc, of required strength, thickness & size/ shape, made by table vibratory method using PU mould, laid in required colour & pattern over 50mm thick compacted bed of sand, compacting and proper embedding/laying of inter locking paver blocks into the sand bedding layer through vibratory compaction by using plate vibrator, filling the joints with sand and cutting of paver blocks as per required size and pattern, finishing and sweeping extra sand. complete all as per direction of Engineer-in-Charge.				
		80 mm thick C.C. paver block of M-30 grade with approved color design and pattern.	Sqm		1400.93	
43		Raising manhole cover and frame slab to required level including dismantling existing				



Sl. No	Ref. SOR-2012/ Rate analysis	Particulars	Unit	Rate (in INR)	Quantity	Amount (in INR)
		slab and making good the damage as required (Raising depth of manhole to be paid separately) :				
		Rectangular manhole 90x80 cm with rectangular cover 600 x 450 mm of grade LD - 2.5	Each		7.00	
		Rectangular manhole 120x90 cm with circular cover 500 mm dia of grade MD - 10	Each		52.00	
		Rectangular manhole 120x90 cm with circular cover 560 mm dia of grade HD - 20	Each			
		Circular manhole 140 cm dia with circular cover 600 mm dia of grade EHD - 35	Each		8.00	
44		Providing & Fixing in position 100 mm dia SS Bollards (SS-304 grade) 1100 mm high, round top, mirror/matte finish of required shape including M.S. holdfast welded at the bottom of the bollard. including necessary excavation for the same in bitumen/ concrete pavement/cast in situ kerbstone at specified spacing. As directed complete	Each		300.30	
45		Erection of metallic pole of following length in cement concrete 1:3:6 (1 cement : 3 coarse sand : 6 graded stone aggregate 40 mm nominal size) foundation including excavation and refilling etc. as required.				
		Above 8.0 metre and upto 11.0 metre	No.		550.00	

Sl. No	Ref. SOR-2012/ Rate analysis	Particulars	Unit	Rate (in INR)	Quantity	Amount (in INR)
46		Providing and fixing in position pre-cast R.C.C. utility chamber cover and frame of required shape and approved quality				
		M D - 10				
		Rectangular shape 600x450 mm internal dimensions	No.		605.00	
47		Supplying and laying of following size DWC HDPE pipe ISI marked along with all accessories like socket, bend, couplers etc. conforming to IS 14930, Part II complete with fitting and cutting, jointing etc. direct in ground as per drawing including excavation and refilling the trench but excluding sand cushioning and protective covering etc. , complete as required.				
		63 mm dia (OD-63 mm & ID-51 mm nominal)	Metre		29700.00	
		238 mm dia (OD-238 mm & ID-200 mm nominal)	Metre		79832.28	
48		Shifting of Existing electric box, including coordination with respective department, shutting supply to avoid accident, excavation, shifting cables as required, foundation for new location, dismantling of existing structure, transportation of excavated material etc. under the supervision of representative of respective department complete as directed by Engineer-in-Charge. Payment against this item will be made	LS		1.00	

Sl. No	Ref. SOR-2012/ Rate analysis	Particulars	Unit	Rate (in INR)	Quantity	Amount (in INR)
		as per actual rate analysis at the time of execution.				
49		Shifting of Existing Telephone box, including coordination with respective department, excavation, shifting cables as required, foundation for new location, dismantling of existing structure, transportation of excavated material etc. under the supervision of representative of respective department, complete as directed by Engineer-in-Charge. Payment against this item will be made as per actual rate analysis at the time of execution.	LS		1.00	
50		Providing and fixing wooden or SS furniture, benches, sitting arrangements. Payment of this item will be as per actual rate analysis as per site condition at the time of execution. Contractor has to get approved all items, furniture from the authority before installing.	LS		1.00	
51		Shifting of 15 mm, 20 mm and 25 mm dia G.I. water supply pipelines complete with G.I. fittings including trenching and refilling etc.:				
		15 mm dia nominal bore	Metre		840.00	
		20 mm dia nominal bore	Metre		840.00	
		25 mm dia nominal bore	Metre		840.00	

SI. No	Ref. SOR-2012/ Rate analysis	Particulars	Unit	Rate (in INR)	Quantity	Amount (in INR)
		Total for Non-SOR Items	II			
		Add GST @ 12% on (II)				
		<b>Non-SOR Items Amount (B)</b>	<b>B</b>			
		TOTAL for all Items	C = A + B			
		Add Contingency @3% on C				
		<b>Grand Total Cost for all Items (incl. all taxes)</b>	<b>(in INR)</b>			

## **PART II REQUIREMENTS**

### **Section 6 - WORKS REQUIREMENTS**

#### **SCOPE OF WORK:**

IMPROVEMENT OF PEDESTRIAN WALKWAY/ FOOTPATH FROM BALUWAKHANI (VAJRA CINEMA HALL) TO RANIPOL, GANGTOK, EAST SIKKIM INCLUDING DEFECT LIABILITY PERIOD OF ONE YEAR

## 6A Standard Specifications

The standard specifications are available for reference, in the office of the employer.

**(The bidder is required to sign the declaration as given in Section IV [Bidding forms] and submit along with the bid)**

In addition to above declaration relevant National and International Standard specifications are to be referred:

## **6B Special Specifications:**

Provided as Volume IV of bidding documents

- (i) The works would be quoted for all lead and lift unless otherwise specified particularly in the document.
- (ii) The Employer does not undertake to construct or make available any approach road to the proposed worksite if not mentioned in the Bill of Quantities and the bidder shall get acquainted with available means of approaches to the proposed site and quote for various items. The Employer shall not be liable for any claim raised later on the plea of non-availability or non-access to the site.

### **1.1. General**

All the materials incorporated in the works shall be the most suitable for the duty concerned and shall be new and of first class commercial quality, free from imperfections and selected for long life and minimum maintenance. It shall be tested according to relevant IS Specifications in qualified labs and certificates produced to the satisfaction of the Project Manager.

If the specification for a particular item is not given, the Standard Specifications of Sikkim PWD or WSPHED or CPWD shall be followed.

The objective of the specifications given in this section is to specify the details pertaining to the design, drawing, and selection of equipment or product. The equipment or product supplied shall be of high standard of quality and best engineering practices and shall comply with all currently applicable standards, regulations and codes.

Except as otherwise specified in this technical specification, the Indian/International Standards and Codes of Practice in their latest version shall be adhered to for the design, manufacturing, inspection, calibration, installation, field testing, packing, handling and transportation of product.

Should any product be offered conforming to other standards, the equipment or products shall be equal to or superior to those specified and the documentary confirmation shall be submitted for the prior approval of the Employer.

**This section is further elaborated in the Special Specification Volume separately provided along with the bid.**

## 6C Drawings (Vol III)

1. **Employer's Drawings:-**The drawings listed in the Tender document are Employer's drawings and are provided by the Employer as a guideline of the specifications and work only. All data and information furnished in the drawings by the Employer is given in good faith but the Employer does not accept the responsibility for the completeness and accuracy thereof. The same shall be verified by the contractor promptly pointing out errors or discrepancies thereof to the Engineer. Drawings are provided as Volume 3 of the bid documents.
2. **Contractor's Drawings:-**All drawings provided by the Contractor shall be on standard size sheets, prepared on computer with Auto CAD Latest revision and shall show particulars in a title block located in the lower right hand corner, in addition to the name of Contractor and equipment manufacturer, date, scale, drawing, revision number (R0 for drawings submitted initially, R1, R2 etc. for drawings submitted subsequently). A blank space shall be provided for the Engineer's approval stamp and provision shall be made for detail of revisions to be recorded. All drawings submitted by the supplier shall use the English language. All drawings shall be clearly and fully cross-referenced to the other drawings as relevant.
3. **The Contractor's attention is drawn to the Special Specification (Volume IV) for more information on the drawing requirement.**

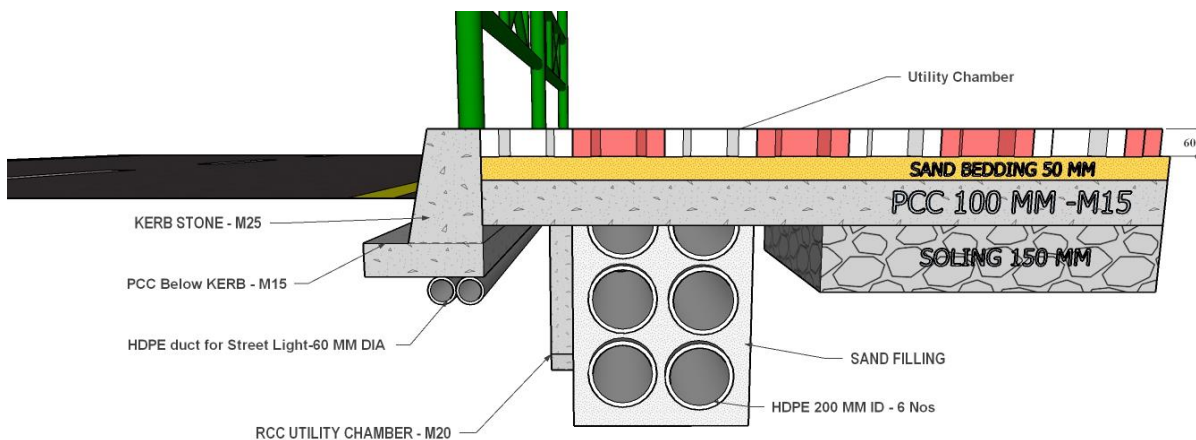
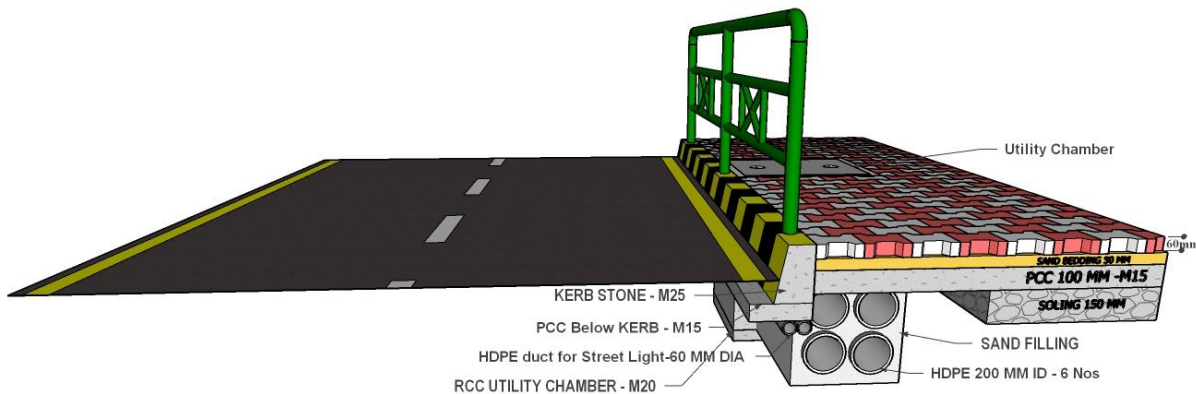

**CROSS-SECTION OF PROPOSED FOOTPATH**



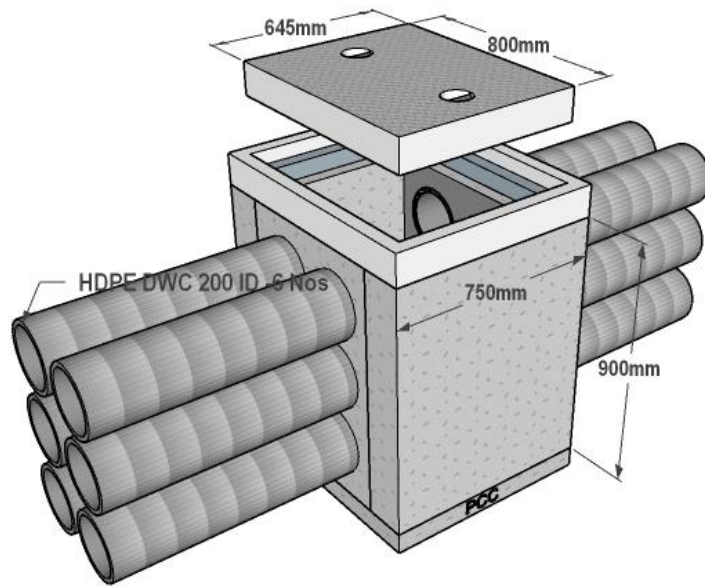

**UTILITY DUCT CHAMBER DETAILS**

## 6D Supplementary Information

1. Co-operation: The Contractor shall establish full co-ordination with the officials of Employer/GSCDL, extend co-operation to complete work.
2. Records procedures and reports: A work order book shall be maintained by the contractor at site/workshop for taking instructions from employer or his representative. The Contractor shall maintain records pertaining to the quality of installation / erection work and inspection, testing, compliance with all technical requirements in respect of all this works as described before. The Contractor shall submit such records to the Employer after the completion of any particular work before submitting the bill.
3. Personnel:-The contractor shall depute sufficient staff to carry out installation, the maintenance and repair work efficiently and satisfactorily. The Contractor shall undertake to comply with applicable legislation and the code of labour law on matters of health, hygiene and safety, and shall assume responsibility for works required in the event of any change in applicable regulations. The contractor shall provide all necessary superintendence during the execution of works and during maintenance. The Contractor's staff shall include adequate and competent persons with proven suitable, previous experience on similar contracts to supervise the works and sufficient skilled, semi-skilled and unskilled labour to ensure completion of works in time. The Contractor shall not remove any representative or skilled labour from the site without prior approval of the Employer's Representative for the proper fulfilling of the contractors obligations under the contract. The contractor or a competent and authorized agent or representative approved in writing by Employer on the basis of qualification and experience to be furnished by the contractor, which approval may at any time be withdrawn, is to be constantly on the works and shall give his whole time to the superintendence of the work.
4. Public Authorities: - The Contractor shall comply with all rules & regulations, bye laws and directives given from time to time by any local or public authority in connection with this work and shall himself pay fees or charges which are leviable on him without any extra cost.
5. Safety:-The Contractor will be responsible for safety of the material supplied and kept in joint custody of the employer and the contractor till completion of contract. The Contractor shall at his own expense arrange for the safety of his labour / supervisor staff employed by him directly or indirectly for performing the work, as per statutory requirement. The Contractor shall report any accident or unusual occurrence with the work at site that take place to employer immediately with the action, which he might have taken.
6. Acquaintance with Site and Work Conditions:-The Bidder shall study the site and general conditions in respect of approaches, labourers, climate and the data included in the tender documents and get it verified with actual inspections of the site, before submitting the tender. In case of doubt about any item or data included in the tender, the same shall be got clarified in pre-bid meeting. Once the tender is accepted, it shall be concluded that the Contractor has verified and made himself conversant with all the details required for completing the work as stipulated conditions and specifications.

# PART III CONDITIONS OF CONTRACT AND CONTRACT FORMS

## Section 7 - GENERAL DIRECTIONS AND CONDITIONS OF CONTRACT

### A. General

#### 1. Definitions

- 1.1. Boldface type is used to identify defined terms.
- (a) The **Accepted Contract Amount** means the amount accepted in the Letter of Acceptance for the execution and completion of the Works and the remedying of any defects.
  - (b) The **Activity Schedule** is a schedule of the activities comprising the construction, installation, testing, and commissioning of the Works in a lump sum contract. It includes a lump sum price for each activity, which is used for valuations and for assessing the effects of Variations and Compensation Events.
  - (c) The **Adjudicator** is the person appointed jointly by the Employer and the Contractor to resolve disputes in the first instance, as provided for in GCC 23.1 hereunder.
  - (d) **Bill of Quantities** means the priced and completed Bill of Quantities forming part of the Bid.
  - (e) **Compensation Events** are those defined in GCC 41.1 hereunder.
  - (f) The **Completion Date** is the date of completion of the Works as certified by the Project Manager, in accordance with GCC 52.1.
  - (g) The **Contract** is the Contract between the Employer and the Contractor to execute, complete, and maintain the Works. It consists of the documents listed in GCC 2.3 below.
  - (h) The **Contractor** is the party whose Bid to carry out the Works has been accepted by the Employer.
  - (i) The **Contractor's Bid** is the completed bidding document submitted by the Contractor to the Employer.
  - (j) The **Contract Price** is the Accepted Contract Amount stated in the Letter of Acceptance and thereafter as adjusted in accordance with the Contract.
  - (k) **Days** are calendar days; months are calendar months.
  - (l) **Day works** are varied work inputs subject to payment on a time basis for the Contractor's employees and Equipment, in addition to payments for associated Materials and Plant.
  - (m) A **Defect** is any part of the Works not completed in accordance with the Contract.

- (n) The **Defects Liability Certificate** is the certificate issued by Project Manager upon correction of defects by the Contractor.
- (o) The **Defects Liability Period** is the period calculated from the Completion Date where the Contractor remains responsible for remedying defects.
- (p) **Drawings** include calculations and other information provided or approved by the Project Manager for the execution of the Contract.
- (q) The **Employer** is the party who employs the Contractor to carry out the Works, as specified in the **PCC**.
- (r) **Equipment** is the Contractor's machinery and vehicles brought temporarily to the Site to construct the Works.
- (s) **Force Majeure** means an exceptional event or circumstance: which is beyond a Party's control; which such Party could not reasonably have provided against before entering into the Contract; which, having arisen, such Party could not reasonably have avoided or overcome; and, which is not substantially attributable to the other Party.
- (t) The **Initial Contract Price** is the Contract Price listed in the Employer's Letter of Acceptance.
- (u) The **Intended Completion Date** is the date on which it is intended that the Contractor shall complete the Works. The Intended Completion Date is specified in the **PCC**. The Intended Completion Date may be revised only by the Project Manager by issuing an extension of time or an acceleration order.
- (v) **Letter of Acceptance** means the formal acceptance by the Employer of the Bid and denotes the formation of the Contract at the date of acceptance.
- (w) **Materials** are all supplies, including consumables, used by the Contractor for incorporation in the Works.
- (x) "**Party**" means the Employer or the Contractor, as the context requires.
- (y) **PCC** means Particular Conditions of Contract
- (z) **Plant** is any integral part of the Works that shall have a mechanical, electrical, chemical, or biological function.
- (aa) The **Project Manager** is the person named in the **PCC** (or any other competent person appointed by the Employer and notified to the Contractor, to act in replacement of the Project Manager) who is responsible for supervising the execution of the Works and administering the Contract.

- (bb) **Retention Money** means the aggregate of all monies retained by the Employer pursuant to GCC 45.1.
- (cc) The **Site** is the area defined as such in the **PCC**.
- (dd) **Site Investigation Reports** are those that were included in the bidding documents and are factual and interpretative reports about the surface and subsurface conditions at the Site.
- (ee) **Specification** means the Specification of the Works included in the Contract and any modification or addition made or approved by the Project Manager.
- (ff) The **Start Date** is given in the **PCC**. It is the latest date when the Contractor shall commence execution of the Works. It does not necessarily coincide with any of the Site Possession Dates.
- (gg) A **Subcontractor** is a person or corporate body who has a Contract with the Contractor to carry out a part of the work in the Contract, which includes work on the Site.
- (hh) **Temporary Works** are works designed, constructed, installed, and removed by the Contractor that are needed for construction or installation of the Works.
- (ii) A **Variation** is an instruction given by the Project Manager which varies the Works.
- (jj) The **Works** are what the Contract requires the Contractor to construct, install, and turn over to the Employer, as defined in the **PCC**.

## 2. Interpretation

- 2.1. In interpreting these GCC, singular also means plural, male also means female or neuter, and the other way around. Headings have no significance. Words have their normal meaning under the language of the Contract unless specifically defined. The Project Manager shall provide instructions clarifying queries about these GCC.
- 2.2. If sectional completion is specified in the PCC, references in the GCC to the Works, the Completion Date, and the Intended Completion Date apply to any Section of the Works (other than references to the Completion Date and Intended Completion Date for the whole of the Works).
- 2.3. The documents forming the Contract shall be interpreted in the following order of priority:
  - a) Agreement,
  - b) Letter of Acceptance,
  - c) Particular Conditions of Contract,
  - d) General Conditions of Contract,
  - e) Specifications,
  - f) Drawings,
  - g) Bill of Quantities (or Schedules of Prices for lump sum contracts), and
  - h) Contractor's Bid,

- i) any other document listed in the PCC as forming part of the Contract.

### **3. Language and Law**

- 3.1. The language of the Contract and the law governing the Contract are stated in the PCC.

### **4. Project Manager's Decisions**

- 4.1. Except where otherwise specifically stated, the Project Manager shall decide contractual matters between the Employer and the Contractor in the role representing the Employer.

### **5. Delegation**

- 5.1. The Project Manager may delegate any of his duties and responsibilities to other people except to the Adjudicator, after notifying the Contractor, and may cancel any delegation after notifying the Contractor.

### **6. Communications**

- 6.1. Communications between parties that are referred to in the Conditions shall be effective only when in writing. A notice shall be effective only when it is delivered

### **7. Subcontracting**

- 7.1. The Contractor may subcontract with the approval of the Project Manager, but may not assign the Contract without the approval of the Employer in writing. Subcontracting shall not alter the Contractor's obligations.

### **8. Other Contractors**

- 8.1. The Contractor shall cooperate and share the Site with other contractors, public authorities, utilities, and the Employer between the dates given in the Schedule of Other Contractors, as referred to in the PCC. The Contractor shall also provide facilities and services for them as described in the Schedule. The Employer may modify the Schedule of other Contractors, and shall notify the Contractor of any such modification.

### **9. Personnel and Equipment**

- 9.1. The Contractor shall employ the key personnel and use the equipment identified in its Bid to carry out the Works, or other personnel and equipment approved by the Project Manager. The Project Manager shall approve any proposed replacement of key personnel and equipment only if their relevant qualifications or characteristics are substantially equal to or better than those proposed in the Bid.
- 9.2. If the Project Manager asks the Contractor to remove a person who is a member of the Contractor's staff or work force, stating the reasons, the Contractor shall ensure that the person leaves the Site within seven days and has no further connection with the work in the Contract.

## **10. Employer's and Contractor's Risks**

- 10.1. The Employer carries the risks which this Contract states are Employer's risks, and the Contractor carries the risks which this Contract states are Contractor's risks.

## **11. Employer's Risks**

- 11.1. From the Start Date until the Defects Liability Certificate has been issued, the following are Employer's risks:
- (a) The risk of personal injury, death, or loss of or damage to property (excluding the Works, Plant, Materials, and Equipment), which are due to
    - (i) use or occupation of the Site by the Works or for the purpose of the Works, which is the unavoidable result of the Works or
    - (ii) negligence, breach of statutory duty, or interference with any legal right by the Employer or by any person employed by or contracted to him except the Contractor.
  - (b) The risk of damage to the Works, Plant, Materials, and Equipment to the extent that it is due to a fault of the Employer or in the Employer's design, or due to war or radioactive contamination directly affecting the country where the Works are to be executed.
- 11.2. From the Completion Date until the Defects Liability Certificate has been issued, the risk of loss of or damage to the Works, Plant, and Materials is an Employer's risk except loss or damage due to
- (a) a Defect which existed on the Completion Date,
  - (b) an event occurring before the Completion Date, which was not itself an Employer's risk, or
  - (c) the activities of the Contractor on the Site after the Completion Date.

## **12. Contractor's Risks**

- 12.1. From the Starting Date until the Defects Liability Certificate has been issued, the risks of personal injury, death, and loss of or damage to property (including, without limitation, the Works, Plant, Materials, and Equipment) which are not Employer's risks are Contractor's risks.

## **13. Insurance**

- 13.1 The Contractor shall provide, in the joint names of the Employer and the Contractor, insurance cover from the Start Date to the end of the Defects Liability Period, in the amounts and deductibles stated in the PCC for the following events which are due to the Contractor's risks:
- (a) loss of or damage to the Works, Plant, and Materials;
  - (b) loss of or damage to Equipment;
  - (c) loss of or damage to property (except the Works, Plant, Materials, and Equipment) in connection with the Contract; and

- (d) personal injury or death.
- 13.2 Policies and certificates for insurance shall be delivered by the Contractor to the Project Manager for the Project Manager's approval before the Start Date. All such insurance shall provide for compensation to be payable in the types and proportions of currencies required to rectify the loss or damage incurred.
- 13.3 If the Contractor does not provide any of the policies and certificates required, the Employer may affect the insurance which the Contractor should have provided and recover the premiums the Employer has paid from payments otherwise due to the Contractor or, if no payment is due, the payment of the premiums shall be a debt due.
- 13.4 Alterations to the terms of insurance shall not be made without the approval of the Project Manager.
- 13.5 Both parties shall comply with any conditions of the insurance policies.

#### **14. Site Investigation Reports**

- 14.1. The Contractor, in preparing the Bid, shall rely on any Site Investigation Reports referred to in the PCC, supplemented by any information available to the Bidder.

#### **15. Contractor to Construct the Works**

- 15.1. The Contractor shall construct and install the Works in accordance with the Specifications and Drawings.

#### **16. The Works to Be Completed by the Intended Completion Date**

- 16.1. The Contractor may commence execution of the Works on the Start Date and shall carry out the Works in accordance with the Program submitted by the Contractor, as updated with the approval of the Project Manager, and complete them by the Intended Completion Date.

#### **17. Designs by Contractor and Approval by the Project Manager**

- 17.1. The Contractor shall carry out design to the extent specified in the PCC. The Contractor shall promptly submit to the Employer all designs prepared by him. Within 14 days of receipt, the Employer shall notify any comments. The Contractor shall not construct any element of the permanent work designed by him within 14 days after the design has been submitted to the Employer or where the design for that element has been rejected. Design that has been rejected shall be promptly amended and resubmitted. The Contractor shall resubmit all designs commented on taking these comments into account as necessary.
- 17.2. The Contractor shall be responsible for design of Temporary Works.
- 17.3. The Contractor shall submit Specifications and Drawings showing the proposed Temporary Works to the Project Manager, who is to approve them if they comply with the Specifications and Drawings.
- 17.4. The Project Manager's approval shall not alter the Contractor's responsibility for design of the Temporary Works.



- 17.5. The Contractor shall obtain approval of third parties to the design of the Temporary Works, where required.
- 17.6. All Drawings prepared by the Contractor for the execution of the temporary or permanent Works, are subject to prior approval by the Project Manager before this use.

## **18. Safety**

- 18.1. The Contractor shall be responsible for the safety of all activities on the Site.

## **19. Discoveries**

- 19.1. Anything of historical or other interest or of significant value unexpectedly discovered on the Site shall be the property of the Employer. The Contractor shall notify the Project Manager of such discoveries and carry out the Project Manager's instructions for dealing with them.

## **20. Possession of the Site**

- 20.1 The Employer shall give possession of all parts of the Site to the Contractor. If possession of a part is not given by the date stated in the PCC, the Employer shall be deemed to have delayed the start of the relevant activities, and this shall be a Compensation Event. The final authority on this matter shall lie with the GSCDL and decision in this matter taken by GSCDL will be binding on all parties to this contract.

## **21. Access to the Site**

- 21.1. The Contractor shall allow the Project Manager and any person authorized by the Project Manager access to the Site and to any place where work in connection with the Contract is being carried out or is intended to be carried out.

## **22. Instructions, Inspections and Audits**

- 22.1. The Contractor shall carry out all instructions of the Project Manager which comply with the applicable laws where the Site is located.
- 22.2. The Contractor shall permit the GSCDL to inspect the Contractor's accounts, records and other documents relating to the submission of bids and contract performance and to have them audited by auditors appointed by the GSCDL. The Contractor shall maintain all documents and records related to the Contract for a period of three (3) years after completion of the Works. The Contractor shall provide any documents necessary for the investigation of allegations of fraud, collusion, coercion, or corruption and require its employees or agents with knowledge of the Contract to respond to questions from the GSCDL.

## **23. Appointment of the Adjudicator**

- 23.1. The Adjudicator shall be appointed jointly by the Employer and the Contractor, at the time of the Employer's issuance of the Letter of Acceptance. If, in the Letter of

Acceptance, the Employer does not agree on the appointment of the Adjudicator, the Employer will request the Appointing Authority designated in the PCC, to appoint the Adjudicator within 14 days of receipt of such request.

- 23.2. Should the Adjudicator resign or die, or should the Employer and the Contractor agree that the Adjudicator is not functioning in accordance with the provisions of the Contract; a new Adjudicator shall be jointly appointed by the Employer and the Contractor. In case of disagreement between the Employer and the Contractor, within 30 days, the Adjudicator shall be designated by the Appointing Authority at the request of either party, within 14 days of receipt of such request.

#### **24. Procedure for Disputes**

- 24.1. If the Contractor believes that a decision taken by the Project Manager was either outside the authority given to the Project Manager by the Contract or that the decision was wrongly taken, the decision shall be referred to the Adjudicator within 14 days of the notification of the Project Manager's decision.
- 24.2. The Adjudicator shall give a decision in writing within 28 days of receipt of a notification of a dispute.
- 24.3. The Adjudicator shall be paid at the rate specified in the PCC, together with reimbursable expenses of the types specified in the Contract Data, and the cost shall be divided equally between the Employer and the Contractor, whatever decision is reached by the Adjudicator. Either party may refer a decision of the Adjudicator to an Arbitrator within 28 days of the Adjudicator's written decision. If neither party refers the dispute to arbitration within the above 28 days, the Adjudicator's decision shall be final and binding.
- 24.4. The arbitration shall be conducted in accordance with the arbitration procedures published by the institution named and in the place specified in the PCC.

#### **B. Time Control**

#### **25. Program**

- 25.1. Within the time stated in the PCC, after the date of the Letter of Acceptance, the Contractor shall submit to the Project Manager for approval a Program showing the general methods, arrangements, order, and timing for all the activities in the Works. In the case of a lump sum contract, the activities in the Program shall be consistent with those in the Activity Schedule.
- 25.2. An update of the Program shall be a program showing the actual progress achieved on each activity and the effect of the progress achieved on the timing of the remaining work, including any changes to the sequence of the activities.
- 25.3. The Contractor shall submit to the Project Manager for approval an updated Program at intervals no longer than the period stated in the PCC. If the Contractor does not submit an updated Program within this period, the Project Manager may withhold the amount stated in the PCC from the next payment certificate and continue to withhold this amount until the next payment after the date on which the overdue Program has been submitted.

In the case of a lump sum contract, the Contractor shall provide an updated Activity Schedule within 14 days of being instructed to by the Project Manager.

- 25.4. The Project Manager's approval of the Program shall not alter the Contractor's obligations. The Contractor may revise the Program and submit it to the Project Manager again at any time. A revised Program shall show the effect of Variations and Compensation Events.

## **26. Extension of the Intended Completion Date**

- 26.1. The Project Manager shall extend the Intended Completion Date if a Compensation Event occurs or a Variation is issued which makes it impossible for Completion to be achieved by the Intended Completion Date without the Contractor taking steps to accelerate the remaining work, which would cause the Contractor to incur additional cost.
- 26.2. The Project Manager shall decide whether and by how much to extend the Intended Completion Date within 21 days of the Contractor asking the Project Manager for a decision upon the effect of a Compensation Event or Variation and submitting full supporting information. If the Contractor has failed to give early warning of a delay or has failed to cooperate in dealing with a delay, the delay by this failure shall not be considered in assessing the new Intended Completion Date.

## **27. Acceleration**

- 27.1. When the Employer wants the Contractor to complete works before the Intended Completion Date, the Project Manager appointed by employer shall obtain priced proposals for achieving the necessary acceleration of works from the Contractor. If the Employer accepts these proposals, the Intended Completion Date shall be adjusted accordingly and confirmed by both the Employer and the Contractor.
- 27.2. If the Contractor's priced proposals for acceleration are accepted by the Employer, they are incorporated in the Contract Price and treated as a Variation.

## **28. Delays Ordered by the Project Manager**

- 28.1. The Project Manager may instruct the Contractor to delay the start or progress of any activity within the Works.

## **29. Management Meetings**

- 29.1. Either the Project Manager or the Contractor may require the other to attend a management meeting. The business of a management meeting shall be to review the plans for remaining work and to deal with matters raised in accordance with the early warning procedure.
- 29.2. The Project Manager shall record the business of management meetings and provide copies of the record to those attending the meeting and to the Employer. The responsibility of the parties for actions to be taken shall be decided by the Project

Manager either at the management meeting or after the management meeting and stated in writing to all who attended the meeting.

### **30. Early Warning**

- 30.1. The Contractor shall warn the Project Manager at the earliest opportunity of specific likely future events or circumstances that may adversely affect the quality of the work, increase the Contract Price, or delay the execution of the Works. The Project Manager may require the Contractor to provide an estimate of the expected effect of the future event or circumstance on the Contract Price and Completion Date. The estimate shall be provided by the Contractor as soon as reasonably possible.
- 30.2. The Contractor shall cooperate with the Project Manager in making and considering proposals for how the effect of such an event or circumstance can be avoided or reduced by anyone involved in the work and in carrying out any resulting instruction of the Project Manager.

## **C. Quality Control**

### **31. Identifying Defects**

- 31.1. The Project Manager and PDMC appointed by GSCDL shall check the Contractor's work and notify the Contractor of any Defects that are found. Such checking shall not affect the Contractor's responsibilities. The Project Manager may instruct the Contractor to search for a Defect and to uncover and test any work that the Project Manager considers may have a Defect.

### **32. Tests**

- 32.1. If the Project Manager instructs the Contractor to carry out a test not specified in the Specification to check whether any work has a Defect and the test shows that it does, the Contractor shall pay for the test and any samples. If there is no Defect, the test shall be a Compensation Event.

### **33. Correction of Defects**

- 33.1. The Project Manager shall give notice to the Contractor of any Defects before the end of the Defects Liability Period, which begins at Completion, and is defined in the PCC. The Defects Liability Period shall be extended for as long as Defects remain to be corrected.
- 33.2. Every time notice of a Defect is given, the Contractor shall correct the notified Defect within the length of time specified by the Project Manager's notice.

### **34. Uncorrected Defects**

- 34.1. If the Contractor has not corrected a Defect within the time specified in the Project Manager's notice, the Project Manager shall assess the cost of having the Defect corrected, and the Contractor shall pay this amount.

### **D. Cost Control**

### **35. Contract Price**

- 35.1. In the case of an admeasurements contract, the Bill of Quantities shall contain priced items for the Works to be performed by the Contractor. The Bill of Quantities is used to calculate the Contract Price. The Contractor will be paid for the quantity of the work accomplished at the rate in the Bill of Quantities for each item.
- 35.2. In the case of a lump sum contract, the Activity Schedule shall contain the priced activities for the Works to be performed by the Contractor. The Activity Schedule is used to monitor and control the performance of activities on which basis the Contractor will be paid. If payment for Materials on Site shall be made separately, the Contractor shall show delivery of Materials to the Site separately on the Activity Schedule.

### **36. Changes in the Contract Price**

- 36.1. In the case of an admeasurements contract:
  - (a) If the final quantity of the work done differs from the quantity in the Bill of Quantities for the particular item by more than 25 percent, provided the change exceeds 1 percent of the Initial Contract Price, the Project Manager shall adjust the rate to allow for the change.
  - (b) The Project Manager shall not adjust rates from changes in quantities if thereby the Initial Contract Price is exceeded by more than 15 percent, except with the prior approval of the Employer.
  - (c) If requested by the Project Manager, the Contractor shall provide the Project Manager with a detailed cost breakdown of any rate in the Bill of Quantities.
- 36.2. In the case of a lump sum contract, the Activity Schedule shall be amended by the Contractor to accommodate changes of Program or method of working made at the Contractor's own discretion. Prices in the Activity Schedule shall not be altered when the Contractor makes such changes to the Activity Schedule.

### **37. Variations**

- 37.1. All Variations shall be included in updated Programs, produced by the Contractor.
- 37.2. The Contractor shall provide the Project Manager with a quotation for carrying out the Variation when requested to do so by the Project Manager. The Project Manager shall assess the quotation, which shall be given within seven (7) days of the request or within any longer period stated by the Project Manager and before the Variation is ordered.

- 37.3. If the Contractor's quotation is unreasonable, the Project Manager may order the Variation and make a change to the Contract Price, which shall be based on the Project Manager's own forecast of the effects of the Variation on the Contractor's costs.
- 37.4. If the Project Manager decides that the urgency of varying the work would prevent a quotation being given and considered without delaying the work, no quotation shall be given and the Variation shall be treated as a Compensation Event.
- 37.5. The Contractor shall not be entitled to additional payment for costs that could have been avoided by giving early warning.
- 37.6. In the case of an admeasurements contract, if the work in the Variation corresponds to an item description in the Bill of Quantities and if, in the opinion of the Project Manager, the quantity of work above the limit stated in GCC 36.1 or the timing of its execution do not cause the cost per unit of quantity to change, the rate in the Bill of Quantities shall be used to calculate the value of the Variation. If the cost per unit of quantity changes, or if the nature or timing of the work in the Variation does not correspond with items in the Bill of Quantities, the quotation by the Contractor shall be in the form of new rates for the relevant items of work.

### **38. Cash Flow Forecasts**

- 38.1. When the Program, or, in the case of a lump sum contract, the Activity Schedule, is updated, the Contractor shall provide the Project Manager with an updated cash flow forecast. The cash flow forecast shall include different currencies, as defined in the Contract, converted as necessary using the Contract exchange rates.

### **39. Payment Certificates**

- 39.1. The Contractor shall submit to the Project Manager monthly statements of the estimated value of the work executed less the cumulative amount certified previously.
- 39.2. The Project Manager shall check the Contractor's monthly statement and certify the amount to be paid to the Contractor.
- 39.3. The value of work executed shall be determined by the Project Manager.
- 39.4. The value of work executed shall comprise:
  - (a) In the case of an admeasurements contract, the value of the quantities of work in the Bill of Quantities that have been completed; or
  - (b) In the case of a lump sum contract, the value of work executed shall comprise the value of completed activities in the Activity Schedule.
- 39.5. The value of work executed shall include the valuation of Variations and Compensation Events.
- 39.6. The Project Manager may exclude any item certified in a previous certificate or reduce the proportion of any item previously certified in any certificate in the light of later information.

#### **40. Payments**

- 40.1. Payments shall be adjusted for deductions for advance payments & its interests and retention. The Employer shall pay the Contractor the amounts certified by the Project Manager according to each certificate.
- 40.2. If an amount certified is increased in a later certificate or as a result of an award by the Adjudicator or an Arbitrator same shall be paid to contractor.
- 40.3. Unless otherwise stated, all payments and deductions shall be paid or charged in the proportions of currencies comprising the Contract Price.
- 40.4. Items of the Works for which no rate or price has been entered in shall not be paid for by the Employer and shall be deemed covered by other rates and prices in the Contract.

#### **41. Compensation Events**

- 41.1. The following shall be Compensation Events:
  - (a) The Employer does not give access to a part of the Site by the Site Possession Date pursuant to GCC 20.1.
  - (b) The Employer modifies the Schedule of Other Contractors in a way that affects the work of the Contractor under the Contract.
  - (c) The Project Manager orders a delay or does not issue Drawings, Specifications required for execution of the Works on time.
  - (d) The Project Manager instructs the Contractor to uncover or to carry out additional tests upon work, which is then found to have no Defects.
  - (e) Ground conditions are substantially more adverse than could reasonably have been assumed before issuance of the Letter of Acceptance from the information issued to bidders (including the Site Investigation Reports), from information available publicly and from a visual inspection of the Site.
  - (f) The Project Manager gives an instruction for dealing with an unforeseen condition, caused by the Employer, or additional work required for safety or other reasons.
  - (g) Other contractors, public authorities, utilities, or the Employer does not work within the dates and other constraints stated in the Contract, and they cause delay or extra cost to the Contractor.
  - (h) The advance payment is delayed.
  - (i) The effects on the Contractor of any of the Employer's Risks.
  - (j) The Project Manager unreasonably delays issuing a Certificate of Completion.
- 41.2. If a Compensation Event would cause additional cost or would prevent the work being completed before the Intended Completion Date, the Contract Price shall be increased and/or the Intended Completion Date shall be extended. The Project Manager shall decide whether and by how much the Contract Price shall be increased and whether and by how much the Intended Completion Date shall be extended.
- 41.3. As soon as information demonstrating the effect of each Compensation Event upon the Contractor's forecast cost has been provided by the Contractor, it shall be assessed by the Project Manager, and the Contract Price shall be adjusted accordingly. If the

Contractor's forecast is deemed unreasonable, the Project Manager shall adjust the Contract Price based on the Project Manager's own forecast. The Project Manager shall assume that the Contractor shall react competently and promptly to the event.

- 41.4. The Contractor shall not be entitled to compensation to the extent that the Employer's interests are adversely affected by the Contractor's not having given early warning or not having cooperated with the Project Manager.

#### **42. Tax**

- 42.1. The rates quoted by the Contractor shall be deemed to be inclusive of all the taxes, levies, etc. including GST including their variations as notified by the concerned authority from time to time, and also of all the new taxes and levies that may be imposed that the Contractor will have to pay for the performance of this Contract. The Employer on behalf of the Employer will perform such duties in regard to the deduction of such taxes at source as per applicable law.
- 42.2. The Contractor shall comply with the proper bye-laws and legal orders of the local body or public authority under the jurisdiction of which the work is executed and pay all fees and charges for which he may be liable. Nothing extra shall be payable on this account.

#### **43. Currencies**

- 43.1. Where payments are made in currencies other than the currency of the Employer's country specified in the PCC, the exchange rates used for calculating the amounts to be paid shall be the exchange rates stated in the Contractor's Bid.

#### **44. Price Adjustment**

- 44.1. Prices shall be adjusted for fluctuations in the cost of inputs only if provided for in the PCC. If so provided, the amounts certified in each payment certificate, before deducting for Advance Payment, shall be adjusted by applying the respective price adjustment factor to the payment amounts due in each currency. A separate formula of the type indicated below applies to each Contract currency:

$$P_c = A_c + B_c \frac{I_{mc}}{I_{oc}}$$

where:

$P_c$  is the adjustment factor for the portion of the Contract Price payable in a specific currency "c."

$A_c$  and  $B_c$  are coefficients specified in the PCC, representing the nonadjustable and adjustable portions, respectively, of the Contract Price payable in that specific currency "c;" and  $I_{mc}$  is a consolidated index prevailing at the end of the month being invoiced and  $I_{oc}$  is the same consolidated index prevailing 28 days before Bid opening for inputs payable; both in the specific currency "c."

- 44.2. If the value of the index is changed after it has been used in a calculation, the calculation shall be corrected and an adjustment made in the next payment certificate. The index value shall be deemed to take account of all changes in cost due to fluctuations in costs.



#### **45. Retention**

- 45.1. The Employer shall retain from each payment due to the Contractor the proportion stated in the PCC until Completion of the whole of the Works.
- 45.2. Upon the issue of a Certificate of Completion of the Works by the Project Manager, in accordance with GCC 52.1, half the total amount retained shall be repaid to the Contractor and half when the Defects Liability Period has passed and the Project Manager has certified that all Defects notified by the Project Manager to the Contractor before the end of this period have been corrected. The Contractor may substitute retention money with an “on demand” bank guarantee.

#### **46. Liquidated Damages**

- 46.1. The Contractor shall pay liquidated damages to the Employer as compensation for delay at the rate per day stated in the PCC for each day that the Completion Date is later than the Intended Completion Date. The total amount of liquidated damages shall not exceed the amount defined in the PCC. The Employer may deduct liquidated damages from payments due to the Contractor. Payment of liquidated damages shall not affect the Contractor's liabilities.
- 46.2. If the Intended Completion Date is extended after liquidated damages have been paid, the Project Manager shall correct any overpayment of liquidated damages by the Contractor by adjusting the next payment certificate. The Contractor shall be paid interest on the overpayment, calculated from the date of payment to the date of repayment, at the rates specified in GCC 40.1.

#### **47. Bonus**

- 47.1. The Contractor shall be paid a Bonus calculated at the rate per calendar day stated in the PCC for each day (less any days for which the Contractor is paid for acceleration) that the Completion is earlier than the Intended Completion Date. The Project Manager shall certify that the Works are complete, although they may not be due to be complete.

#### **48. Advance Payment**

- 48.1. The Employer shall make advance payment of not more five percent of the estimated cost put to tender or five percent of tender value whichever is more may be given with the approval of the competent authority, if requested by the contractor in writing within one month of the order to commence the work as stated in the PCC by the date stated in the PCC, against provision by the Contractor of an unconditional bank guarantee bond in a form and by a bank acceptable to the Employer in amounts and currencies equal to 110% to the advance payment amount. The bank guarantee shall remain effective until the advance payment has been repaid, but the amount of the bank guarantee shall be progressively reduced by the amounts repaid by the Contractor. Interest on mobilization advance shall be levied as per the Government Notification and as amended prior to conclusion of this contract. The amount of mobilization advance, if paid to the contractor,

shall be recovered from each monthly bill / running account bill payable to the contractor for the work done so that the entire amount is recovered before completion of 60% of the Contract value. In case of any difficulty in recovering the advance, it shall be recovered from the bank guarantee given by the Contractor. The Contractor may, at his option, can repay the advance earlier by increasing the percentage rate of deductions from invoice raised.

- 48.2. The Contractor is to use the advance payment only to pay for Equipment, Plant, Materials, and mobilization expenses required specifically for execution of the Contract. The Contractor shall demonstrate that advance payment has been used in this way by supplying copies of invoices or other documents to the Project Manager.

#### **49. Securities**

- 49.1. The Performance Security shall be provided to the Employer no later than the date specified in the Letter of Acceptance and shall be issued in an amount specified in the PCC, by a bank acceptable to the Employer, and denominated in the types and proportions of the currencies in which the Contract Price is payable. The Performance Security shall be valid until a date 28 days from the date of issue of the Certificate of Completion in the case of a bank guarantee.

#### **50. Day works**

- 50.1. If applicable, the Day works rates in the Contractor's Bid shall be used for small additional amounts of work only when the Project Manager has given written instructions in advance for additional work to be paid for in that way.
- 50.2. All work to be paid for as Day works shall be recorded by the Contractor on forms approved by the Project Manager. Each completed form shall be verified and signed by the Project Manager within two days of the work being done.
- 50.3. The Contractor shall be paid for Day works subject to obtaining signed Day works forms.

#### **51. Cost of Repairs**

- 51.1. Loss or damage to the Works or Materials to be incorporated in the Works between the Start Date and the end of the Defects Correction periods shall be remedied by the Contractor at the Contractor's cost if the loss or damage arises from the Contractor's acts or omissions.

### **E. Finishing the Contract**

#### **52. Completion**

- 52.1. The Contractor shall request the Project Manager to issue a certificate of Completion of the Works, and the Project Manager shall do so upon deciding that the work is completed.

### **53. Taking Over**

- 53.1. The Employer shall take over the Site and the Works within seven days of the Project Manager's issuing a certificate of Completion.

### **54. Final Account**

- 54.1. The Contractor shall supply the Project Manager with a detailed account of the total amount that the Contractor considers payable under the Contract before the end of the Defects Liability Period. The Project Manager shall issue a Defects Liability Certificate and certify any final payment that is due to the Contractor within 56 days of receiving the Contractor's account if it is correct and complete. If it is not, the Project Manager shall issue within 56 days a schedule that states the scope of the corrections or additions that are necessary. If the Final Account is still unsatisfactory after it has been resubmitted, the Project Manager shall decide on the amount payable to the Contractor and issue a payment certificate.

### **55. Operating and Maintenance Manuals**

- 55.1. If "as built" Drawings and/or operating and maintenance manuals are required, the Contractor shall supply them by the dates stated in the PCC.
- 55.2. If the Contractor does not supply the Drawings and/or manuals by the dates stated in the PCC pursuant to GCC 55.1, or they do not receive the Project Manager's approval, the Project Manager shall withhold the amount stated in the PCC from payments due to the Contractor.

### **56. Termination**

- 56.1. The Employer or the Contractor may terminate the Contract if the other party causes a fundamental breach of the Contract.
- 56.2. Fundamental breaches of Contract shall include, but shall not be limited to, the following:
  - (a) the Contractor stops work for 28 days when no stoppage of work is shown on the current Program and the stoppage has not been authorized by the Project Manager;
  - (b) the Project Manager instructs the Contractor to delay the progress of the Works, and the instruction is not withdrawn within 28 days;
  - (c) the Employer or the Contractor is made bankrupt or goes into liquidation other than for a reconstruction or amalgamation;
  - (d) a payment certified by the Project Manager is not paid by the Employer to the Contractor within 84 days of the date of the Project Manager's certificate;
  - (e) the Project Manager gives Notice that failure to correct a particular Defect is a fundamental breach of Contract and the Contractor fails to correct it within a reasonable period of time determined by the Project Manager;
  - (f) the Contractor does not maintain a Security, which is required; and

- (g) the Contractor has delayed the completion of the Works by the number of days for which the maximum amount of liquidated damages can be paid, as defined in the PCC.
  - (h) if the Contractor, in the judgment of the Employer has engaged in corrupt or fraudulent practices in competing for or in executing the Contract, pursuant to GCC 57.1.
- 56.3. When either party to the Contract gives notice of a breach of Contract to the Project Manager for a cause other than those listed under GCC 56.2 above, the Project Manager shall decide whether the breach is fundamental or not.
- 56.4. Notwithstanding the above, the Employer may terminate the Contract for convenience.
- 56.5. If the Contract is terminated, the Contractor shall stop work immediately, make the Site safe and secure, and leave the Site as soon as reasonably possible.

### **57. Fraud and Corruption**

- 57.1. GSCDL requires Contractors, Subcontractors, manufacturers & Suppliers, observe the highest standard of ethics during the procurement and execution of contract(s). In pursuit of this policy, the GSCDL:
- (a) defines, for the purposes of this provision, the terms set forth below as follows:
    - (i) “corrupt practice” means the offering, giving, receiving, or soliciting, directly or indirectly, anything of value to influence improperly the actions of another party;
    - (ii) “fraudulent practice” means any act or omission, including a misrepresentation, that knowingly or recklessly misleads, or attempts to mislead, a party to obtain a financial or other benefit or to avoid an obligation;
    - (iii) “coercive practice” means impairing or harming, or threatening to impair or harm, directly or indirectly, any party or the property of the party to influence improperly the actions of a party;
    - (iv) “collusive practice” means an arrangement between two or more parties designed to achieve an improper purpose, including influencing improperly the actions of another party.
  - (b) will cancel the allocated contract if GSCDL determines at any time that representatives of the Contractor or sub-contractors if permitted under this contract are found to be engaged in corrupt, fraudulent, collusive or coercive practices during the procurement or the execution of that contract, without the Contractor having taken timely and appropriate action satisfactory to the GSCDL and or competent authority to remedy the situation the said contract would be terminated; and
  - (c) will sanction a firm or individual, including declaring them ineligible, either indefinitely or for a stated period of time, to be awarded a GSCDL financed contract if it at any time determines that they have, directly or through an agent, engaged in corrupt, fraudulent, collusive or coercive practices in competing for, or in executing, a GSCDL-financed contract.

## **58. Payment upon Termination**

- 58.1. If the Contract is terminated because of a fundamental breach of Contract by the Contractor, the Project Manager shall issue a certificate for the value of the work done and Materials ordered less advance payments received up to the date of the issue of the certificate and less the percentage to apply to the value of the work not completed, as indicated in the PCC. Additional Liquidated Damages shall not apply. If the total amount due to the Employer exceeds any payment due to the Contractor, the difference shall be a debt payable to the Employer.
- 58.2. If the Contract is terminated for the Employer's convenience or because of a fundamental breach of Contract by the Employer, the Project Manager shall issue a certificate for the value of the work done, Materials ordered, the reasonable cost of removal of Equipment, repatriation of the Contractor's personnel employed solely on the Works, and the Contractor's costs of protecting and securing the Works, and less advance payments received up to the date of the certificate.

## **59. Property**

- 59.1. All Materials on the Site, Plant, Equipment, Temporary Works, and Works shall be deemed to be the property of the Employer if the Contract is terminated because of the Contractor's default.

## **60. Release from Performance**

- 60.1. If the Contract is frustrated by the outbreak of war or by any other event entirely outside the control of either the Employer or the Contractor, the Project Manager shall certify that the Contract has been frustrated. The Contractor shall make the Site safe and stop work as quickly as possible after receiving this certificate and shall be paid for all work carried out before receiving it and for any work carried out afterwards to which a commitment was made.

## **61. Suspension of Loan or Credit**

- 61.1. deleted

## **62. Eligibility**

- 62.1. The Contractor shall have the Indian nationality. The Contractor shall be deemed to have the nationality of a country if the Contractor is a citizen or is constituted, or incorporated, and operates in conformity with the provisions of the laws of that country. This criterion shall also apply to the determination of the nationality of proposed subcontractors or suppliers for any part of the Contract including related services.
- 62.2. The materials, equipment and services to be supplied under the Contract shall have their origin in India and all expenditures under the Contract will be limited to such materials, equipment, and services. At the Employer's request, the Contractor may be required to provide evidence of the origin of materials, equipment and services.

- 62.3. For purposes of GCC 62.2, “origin” means the place where the materials and equipment are mined, grown, produced or manufactured, and from which the services are provided. Materials and equipment are produced when, through manufacturing, processing, or substantial or major assembling of components, a commercially recognized product results that differs substantially in its basic characteristics or in purpose or utility from its components.

## Section 8 - Particular Conditions of Contract

The following Particular Conditions of Contract shall supplement the GCC. Whenever there is a conflict, the provisions herein shall prevail over those in the GCC.

### PARTICULAR CONDITIONS OF CONTRACT

A. General	
GCC 1.1 (q)	The Employer is CEO, GSCDL, Sokaythang-737102, Gangtok.
GCC 1.1 (u)	The Intended Completion Date for the whole of the Works shall be 8 months including Monsoon and adverse climatic condition from the date of signing the Agreement.
GCCs 1.1 (aa) & 4.1	The Project Manager is General Manager, GSCDL, Sokaythang.
GCC 1.1 (cc)	The Sites are located at Baluwakhani (Vajra Cinema Hall) to Ranipool, Gangtok, East Sikkim, India
GCC 1.1 (ff)	The Start Date shall be 7 days from the date of signing the Agreement.
GCC 1.1 (jj)	The Works consist of <b>“Improvement of Pedestrian Walkway/ Footpath (12 km approx.) from Baluwakhani (Vajra Cinema Hall) to Ranipool, Gangtok, East Sikkim including Defect liability period of one year”</b>
GCC 2.2	Sectional Completions are: No sectional completions
GCC 2.3(i)	Any other written agreement reached between the employer and contractor further to the award of contract shall be in line with the original bidding document only, there will be no contradiction with respect to the clauses, terms and conditions of the original conditions of the contract. The Environment Plan attached hereto as Appendix I shall also form part of the agreement  The following documents also form part of the Contract: Environmental Management Plan, attached hereto as Appendix 1.
GCC 3.1	The language of the contract is English.

	The law that applies to the Contract is the law of Union of India and State of Sikkim. Where there is a conflict between the two, the laws of The Union of India shall prevail.
GCC 8.1	Schedule of other contractors: Nil.
GCC 13.1	<p>13.1.1 Insurance of work and contractor's equipment: The Contractor shall, without limiting his or the Employer's obligations and responsibilities under clause GCC 11, insure:</p> <ul style="list-style-type: none"> <li>(a) the Works, together with materials and Plant for incorporation therein to the full replacement cost</li> <li>(b) an additional sum of 15 per cent of such replacement cost, to cover any additional costs of and incidental to the rectification of loss or damage including professional fees and the cost of demolishing and removing any part of the Works and of removing debris of whatsoever nature "it being understood that such insurance shall provide for compensation to be payable to rectify the loss or damage incurred"</li> <li>(c) the Contractor's Equipment and other things brought onto the Site by the Contractor, for a sum sufficient to provide for their replacement at the Site.</li> </ul> <p>13.1.2 Scope of cover: The insurance in paragraphs (a) and (b) of Sub-Clause 13.1.1 shall be in the joint names of the Contractor and the Employer and shall cover:</p> <ul style="list-style-type: none"> <li>(a) the Employer and the Contractor against all loss or damage from whatsoever cause arising, other than as provided Sub-Clause 13.1.4, from the first working day after the commencement date until the date of issue of the relevant Taking-Over Certificate in respect of the Works or any Section or part thereof as the case may be, and</li> <li>(b) the Contractor for his liability; <ul style="list-style-type: none"> <li>(i) during the Defects Liability Period for loss or damage arising from a cause occurring prior to the commencement of the Defects Liability Period, and</li> <li>(ii) for loss or damage occasioned by the Contractor in the course of any operations carried out by him for the purpose of complying with his obligations under Clause GCC 33.</li> </ul> </li> </ul>



13.1.3	<p>Responsibility for Amount not Recovered: Any amounts not insured or not recovered from the insurers shall be borne by the Employer or the Contractor in accordance with their responsibilities Clause GCC 11 &amp; 12.</p>
13.1.4	<p>Exclusions: There shall be no obligation for the insurance in Sub-Clause 13.1.1 to include loss or damage caused by</p> <ul style="list-style-type: none"> <li>(a) war, hostilities, invasion, and act of foreign enemies.</li> <li>(b) Rebellion, revolution, insurrection or military or usurped power, or civil war.</li> </ul>
13.1.5	<p>Third Party Insurance: The Contractor shall, without limiting his or the Employer's obligations and responsibilities under Clause GCC 63, insure, in the joint names of the Contractor and the Employer, against liabilities for death of or injury to any person (other than as provided in sub-clause 13.1.6 and 13.1.7) or loss or damage to any property (other than the Works) arising out of the performance of the Contract, other than the exception defined in paragraphs (a), (b) and(c) of clause GCC 63.3</p> <p>Such insurance shall be for at least 1 % (one percent of the contract amount) subject to a minimum of Rs.20,00,000/- (Rs. 2 million) per occurrence with number of occurrences unlimited.</p> <p>The insurance policy shall include a cross liability clause such that the insurance shall apply to the Contractor and to the Employer as separate insured.</p>
13.1.6	<p>Insurance for Employers Staff: The Contractor shall also, without limiting his or the employer's obligations insure in the Joint names of the contractor and the Employer, the Employer's staff to extent of 5 numbers and their staff engaged on the works at the site against liabilities for death or injury. The amount for the insurance cover for each of the employer's staff so engaged shall be limited to a minimum of Rs. 3,00,000/- per person or as per the laws governing in state whichever is more. The insurance shall continue until the taking over certificate for the whole of the works is issued. Notwithstanding the amount mentioned above, insurance obtained should satisfy the prevailing rules in this regard.</p>
13.1.7	<p>Accident or Injury to Workmen: The Employer or its representatives shall not be liable for or in respect of any damages or compensation payable to any workman or other person in the employment of the</p>

	<p>Contractor or any subcontractor, other than death or injury resulting from any act or default of the Employer, his agents or servants. The Contractor shall indemnify and keep indemnified the Employer against all such damages and compensation, other than those for which the Employer is liable as aforesaid, and against all claims, proceedings, damages, costs, charges, and expenses whatsoever in respect thereof or in relation thereto.</p> <p>The Contractor shall insure against such liability and shall continue such insurance during the whole time that any person is employed by him on the Works. Provided that, in respect of any persons employed by any Subcontractor, the Contractor's obligations to insure as aforesaid under the Sub-Clause shall be satisfied if the Subcontractor shall have insured against the liability in respect of such persons in such manner that the Employer is indemnified under the policy, but the Contractor shall require such Subcontractor to produce to the Employer, when required, such policy of insurance and the receipt for the payment of the current premium.</p> <p>13.1.8 Personal Accident Insurance: In addition to any other insurance required to be taken out by statutory requirements (e.g. Workmen's Compensation Act 1923), the Contractor shall take out a Personal Accident Insurance in favour of each workman employed by him on the Works. Provided that, in respect of any persons employed by any Sub-Contractor, the Contractor's obligations to insure as aforesaid under this Sub-Clause shall be satisfied if the Sub-Contractor shall have taken out Personal Accident Insurance in respect of his workmen employed on the works and the Contractor shall require such Sub-Contractor to produce to the Employer, when required, such policy of Personal Accident Insurance and the receipt for the payment of the current premium.</p> <p>13.1.9 Evidence and Terms of Insurances: The Contractor shall provide evidence to the Employer as soon as practicable after the respective insurance have been taken out but in any case prior to the start of work at the Site that the insurances required under the Contract have been effected and shall, within 84 days of the Commencement Date, provide the insurance policies to the Employer. When providing such evidence and such policies to the Employer, the Contractor shall notify the Project Manager of so doing. Such insurance policies shall be consistent with the general terms agreed prior to the issue of the Letter of Acceptance. The Contractor shall effect all insurances for which he is responsible with insurers and in terms approved by the Employer.</p>
--	--------------------------------------------------------------------------------------------------------------------------------------------------------------------------------------------------------------------------------------------------------------------------------------------------------------------------------------------------------------------------------------------------------------------------------------------------------------------------------------------------------------------------------------------------------------------------------------------------------------------------------------------------------------------------------------------------------------------------------------------------------------------------------------------------------------------------------------------------------------------------------------------------------------------------------------------------------------------------------------------------------------------------------------------------------------------------------------------------------------------------------------------------------------------------------------------------------------------------------------------------------------------------------------------------------------------------------------------------------------------------------------------------------------------------------------------------------------------------------------------------------------------------------------------------------------------------------------------------------------------------------------------------------------------------------------------------------------------------------------------------------------------------------------------------------------------------------------------------------------------------------------------------------------------------------------------------------------------------------------------------------------------------------------------------------------------------------------------------------------------------------------------------------------------------------------------------------------------------------------------------------------------------------------------------------------------------------------------------------------------------------------------------------------------------------------------------------------------------------------------------------------------------------------------------------------------------------------------------------------------------------------------------------------------------------------------------------------------------------------------

	<p>13.1.10 Adequacy of Insurance: The Contractor shall notify the insurers of changes in the nature, extent or programme for the execution of the Works and ensure the adequacy of the insurances at all times in accordance with the terms of the Contract and shall, when required, produce to the Employer the insurance policies in force and the receipts for payment of the current premium.</p> <p>13.1.11 Remedy on Contractor's failure to Insure: If the Contractor fails to effect and to keep in force any of the insurances required under the Contract, or fails to provide the policies to the Employer within the period required by Clause 13.1.9, then and in any such case the Employer may effect and keep in force any such insurances and pay any premium as may be necessary for that purpose and from time to time and deduct premium amount so paid from any monies due or to become due to the Contractor, or recover the same as a debt due from the Contractor.</p>
GCC 15.1	The Contractor shall construct and install the works in accordance with the specification and drawings.
GCC 17.1	The following shall be designed by the Contractor: Nil
GCC 19.1	<p>Please add the following after the last sentence of GCC 19.1</p> <p>All old curiosities, relic coins, minerals etc., found in the excavation or pulling down shall be the property of the Government. Should any ancient masonry or other old work of interest be opened up, or any religious edifice or relic be involved in removal or destruction, in the execution of a work, a clear report on the matter should be sent to Government through the Employer and orders obtained before the demolition or removal of such works or relics. Similarly, regarding old curiosities etc., obtained during excavation, the Project Manager should consult the District Collector through appropriate channel regarding disposal of the same.</p>
GCC 20.1	The Site Possession Date(s) shall be: 75% of the site free from encroachment and impediment shall be handed over to the contractor within 3 days from the date of issue of instruction of work commencement. Remaining Site shall be handed over to the contractor in accordance with the progress of work.
GCC 23.1	Appointing Authority for the Adjudicator: President, Institution of Engineers- Sikkim chapter. India.

GCC 24.1	Amicable settlement at Project Manager level.
GCC 24.3	Rs. 7500 per day for site visit and as well as for hearing.
GCC 24.4	Published by the Govt. of India arbitration procedure and shall be held at Gangtok, Sikkim. Procedure shall be either by a sole Arbitrator or a three member Arbitrator individually and jointly.
B. Time Control	
GCC 25.1	The Contractor shall submit for approval a Program for the Works within 14 days from the date of the Letter of Acceptance.
GCC 25.3	The period between Program updates is 30 days.  The amount to be withheld for late submission of an updated Program is an amount equal to 5 % of the next interim payments
GCC 29.1	Modified as, The Project Manager or on the request of the Contractor, the Project Manager may convene a management meeting and the Project Manager may require the Contractor to attend the management meeting.
C. Quality Control	
GCC 66	The contractor shall ensure that the raw materials, goods & related services procured/deployed under this contract/project should comply with the technical specifications and other provisions of Contract.  The contractor shall be supply and use and will be held responsible for raw materials, goods & related services under this contract/project shall conform to the standards mentioned in the Sikkim SOR and when no applicable standard is mentioned, the standard shall be equivalent or superior to the official standards whose application is appropriate to the superior quality in reference to as mentioned in description in BoQ.
GCC 33.1	The Defects Liability Period is: 365 days.
D. Cost Control	

<p>GCC 36.1</p>	<p>In the case of an admeasurements contract:</p> <p>Delete Sub Clause 36.1 and replace it with the following:</p> <p>If the final quantity of the work done differs or is expected to differ from the quantity in the Bill of Quantities, no change in the rate or price for that item contained in the Contract shall be considered unless such item accounts for an amount more than 5 percent of the Contract Price and the actual quantity of work executed under that item exceeds the quantity set out in the Bill of Quantities by more than 25 percent. For items satisfying the above conditions,</p> <ul style="list-style-type: none"> <li>i. The data rate based on schedule of rate of the year of execution or market rate (when Schedule of Rate is not available)</li> <p style="text-align: center;">or</p> <li>ii. 1.5 times the quoted rate for that item in the contract whichever is less will be the rate for payment for the variation quantity. However for the variation to become applicable, the variation shall be above 125% of the BOQ for civil works.</li> <li>iii. For equipments like pump sets, motor, generators etc. the variation will be based only on the number of units in excess of 125% of the quantity given in BOQ and subjected to a minimum of additional 1 unit or more rounded upwards.</li> <li>iv. Request by the Contractor for variation of rates in the Bill of Quantities will be considered only after the expiry of the Bid validity period or 4 months after the commencement of work whichever comes later.</li> </ul>
<p>GCC 37.6</p>	<p>Modified as:</p> <p>New Items / Extra Items</p> <p>If the work in the variation corresponds with an item description in the Bill of Quantities and if, in the opinion of the Engineer, the quantity of work to be executed is an extra item and the rates in the bill of quantities shall be used for calculate the value of variation. If the cost per unit of quantity changes, or if the nature or timing of the work in the variation does not correspond with item in the BoQ, the procedure explained in the above Para i.e., 36.1 (i), the data rate based on schedule of rate of the year of execution or market rate. (when Schedule of Rate is not available) shall be followed for arriving the rate for the new item.</p>

GCC 39.2	The Project Manager shall within 28 days after receiving a statement and supporting documents from the Contractor, issue to the employer, an Interim Payment Certificate.
GCC 40.1	Payments shall be adjusted for deductions for advance payments and retention.
GCC 42	<p>Add GCC 42.2</p> <p>(i) The rates quoted by the Contractor shall be deemed to be inclusive of all the prevailing taxes/octroi that the Contractor has to pay for performance of this contract. The Employer shall perform such duties in regard to the deduction of such taxes as per statutory deduction requirements at the source of payment as per applicable rules.</p> <p>GCC 42.3</p> <p>(i) Exemptions: If any exemptions are available on Excise Duty and Customs Duty approved by Government of India and implemented by the Sikkim Government then the following conditions shall be applied.</p> <p>The bidder shall refer such notifications/circulars/orders of the Government of India issued from time to time and shall quote his rates accordingly considering the exemptions available. The Employer will give the necessary certificates to the selected bidders to claim the exemption on specific requests made by the Contractor. Any conditional bids in this regard will not be accepted. The quoted rates should be based on the exemptions available and it will be responsibility of the Contractor to avail the exemptions, as per the contents of the notifications/circulars/orders, the Employers responsibility being limited to the issue of necessary certificates and will not take any responsibility of any kind in this regard.</p> <p>(ii) It may also be noted that if the Government of India announces any exemptions on any statutory levies in future also during the tenure of the Contract, all the benefits accruing in view of such further exemptions of any kind on the taxes, Excise Duty, Customs Duty on the Goods used for this Project, shall be passed on to the Employer.</p> <p>(iii) A declaration (as shown in Sec 9 Contract Forms) to the effect should be submitted by the Contractor for the required quantities of Goods/Materials as per BOQ at the time of submission of bid.</p>

GCC 43.1	The currency of the Employer's country is: INR.
GCC 44.1	<p>Price Adjustment Clause is not Applicable for this Contract Package as the intended contract period is less than 18 months. Prices payable to the Contractor, in accordance with the Contract, shall be subject to adjustment during performance of the Contract to reflect changes in the cost of labor and material components, in accordance with the following formula:</p> $P_1 = P_0 \times \left( a + b \frac{L_1}{L_0} + c \frac{M_1}{M_0} \right) - P_0$ <p>in which:</p> <p>P1 = adjustment amount payable to the Contractor</p> <p>P0 = Contract price (base price)</p> <p>a = percentage of fixed element in Contract price (a =25 %)</p> <p>b = percentage of labor component in Contract price (b = % as given table below)</p> <p>c = percentage of material and equipment component in Contract price (c = % as given in table below)</p> <p>L0, L1 = labor indices applicable i.e. consumer price index for industrial workers provided by Guwahati Centre of Labour Bureau Of Government of India on the base date and the date for adjustment, respectively labour</p> <p>M0, M1= For material and equipment index will be wholesale price index of all commodities published by RBI on the base date and the date for adjustment, respectively.</p> <p>The following conditions shall apply:</p> <p>(a) No price increase will be allowed beyond the original completion date unless covered by an extension of time awarded by the Employer under the terms of the Contract. No price increase will be allowed for periods of delay for which the Contractor is responsible. The Employer will, however, be entitled to any price decrease occurring during such periods of delay.</p> <p>(b) If the currency in which the Contract price, P0, is expressed is different from the currency of the country of origin of the labor and/or materials indices, a correction factor will be applied to avoid incorrect adjustments of the Contract price. The</p>

correction factor shall correspond to the ratio of exchange rates between the two currencies on the base date and the date for adjustment as defined above.

(c) No price adjustment shall be payable on the portion of the Contract price paid to the Contractor as an advance payment.

Base, Current and Provisional Indices: the base cost and indices or prices shall be those prevailing on the day 28 days prior to the latest date for submission of Bid. Current indices or prices shall be those prevailing on the quarter for which a particular interim Payment Certificate is related. If at any time the current indices are not available, no provisional escalation will be payable on the basis of indices of the previous quarter in absence of non-publication of indices for concerned quarter by

the RBI. Escalation amount will be payable to the Contractor when the current indices become available.

Weighting and Adjustment Factors: The weightings for each of the factor of cost, unless otherwise provided by the Employer in the Bid Document, shall be proposed by the Contractor in the Bid. The weightings shall be adjusted, if in the opinion of the Employer's Representative, the weightings are

rendered unreasonable, unbalanced or inapplicable as the result of changes in the methods of work, or as a result of varied or additional work already executed or ordered or for any other reason. The decision of the Employer's Representative shall be final and binding to the Contractor.

Adjustable amount: The adjustable amount of each Interim Payment Certificate shall be the difference between (i) the amount which, in the opinion of the Employer's

Representative, shall be due to the contractor including the amount at base rates and prices of the schedule works carried out but excluding provisional sums and the value of materials on the site, and (ii) the amount as calculated in (i) above and included in the last preceding interim payment certificate issued by the Employer's Representative. The adjustable amount shall exclude payments to nominated sub-contractors and any other amounts based upon actual cost or current prices.

Adjusted Amount: The adjusted amount of each payment certificate shall be determined by applying the price adjustment factor to the adjustable amount, and shall become payable to the contractor subject to any deductions there from for retention money, liquidated damages and any other monies due to the Employer from the Contractor including the recovery of advance mobilization, loan if any.

If the Contractor fails to complete the Works within the Time for Completion, adjustments of prices thereafter shall be made using either each index or price applicable on the date 49 days prior to the expiry of the Time for Completion, or the



	<p>current index or price, whichever is more favourable to the Employer, provided that, if an extension of time is granted in accordance with the relevant Sub-Clause the above provision shall apply to the extended time for completion.</p> <p>Table showing percentage of material and labour component</p> <p>☐For Supply of Materials, Equipment and Instrumentation Materials PM = 67.5% and Labor PL = 7.5%</p> <p>For Installation and other services No Adjustment . Factor 0%</p> <p>For General Civil Works Labor PL = 22.5% and Materials PM = 52.5%</p> <p>For Operation and Maintenance of the Facilities if any Labor PL = 67.5% and Materials PM = 7.5%</p>
GCC 45.1 &	The proportion of payments retained from each payment shall be 10% (ten percent) of the payment amount, up to a maximum of 5 % (five percent) of the Contract Price. No interest will be paid for the retention money.
GCC 45.2	50% of retention money will be paid upon issue of completion certificate and remaining 50% upon certification of completion of defect liability period. The Contractor may substitute retention money with an “on demand” bank guarantee.
GCC 46.1	In the event that the contractor fails to comply with the Intended Time of completion for the whole of the Works, or, if applicable, any section within the relevant time, then the Contractor shall pay liquidated damage to the Employer at the rate of 1% (one percent) per day. The maximum amount of liquidated damages for the whole of the works is 10% (ten percent) of the final contract price. Whether the asset is put to use or not the Liquidated Damages will be levied for any delay in completion of works as a part of commitment on the part of the contractor.
GCC 47	Bonus : Not Applicable
GCC 48.1	The Advance Payments shall be: 5 % of the Contract Amount and shall be paid to the Contractor no later than 21 days after the submission of the required Bank Guarantee issued by a Nationalized Bank/Scheduled Bank. The mobilization advance cannot be claimed after the expiry of 4 months from the date of agreement of this contract.
GCC 48.3	The advance payment shall be recovered at a rate of minimum of 10 % (ten percent) of the amount of advance payment from the first and every subsequent bills until the full advance paid has been recovered. However the Project Manager has the

	liberty to recover more than 10 % amount if he feels the pattern of submission of bills of the contractor warrants deduction of more amount for recovery of advance amount. If the advance amount is not recovered fully before the intended time of completion, penalty interest @ 8% will be recovered for the outstanding amount.
GCC 49.1	The Performance Security in the form unconditional and irrevocable bank guarantee issued by a Nationalized Bank/Scheduled Bank located in India for an amount of 10 % of the Contract price. The performance security shall be valid up to 28 days beyond completion of defect liability period.
E. Finishing the Contract	
GCC 55.1	The date by which operating and maintenance manuals are required is within 14 days after completion of the component / milestone  The date by which "As Built" drawings are required is within 14 days after completion of the component / milestone.
GCC 55.2	The amount to be withheld for failing to produce "as built" drawings and/or operating and maintenance manuals by the date required in GCC 55.1 is 5 % of the next interim payment.
GCC 56.2(b)	The contractor has to approach the Project Manager at least 5 days before the expiry of time period of 28 days to get the revised instructions.
GCC 56.2(d)	At least 15 days before the expiry of 84 days' time period, the contractor should address a letter informing the same and requesting for early release of payment.
GCC 56.2 (g)	The maximum number of days is: 100 days.
GCC 58.1	The percentage to apply to the value of the work not completed, representing the Employer's additional cost for completing the Works, is 20%.
	The Contractor shall comply with all applicable national and local environmental laws and regulations.  The Contractor shall (a) establish an operational system for managing environmental impacts, (b) carry out all the monitoring and mitigating measures as set forth in Project's Environmental Management Plan (EMP), attached here to as Appendix 1 (the actual costs for the implementation of such measures shall be

	reimbursed by the Employer from provision sums). The contractor shall submit to the Employer quarterly report on the carrying out of such measures.
	The Contractor Shall :(a) comply with all applicable labor laws, and (b) provide equal pay for men and women for work of equal value or type.
	The Contractor shall not employ child labor, as defined in national legislation for construction and maintenance activities.
	The Contractor shall give priority to the employment of local people, who meet the job and efficiency requirements, for the Contract works.
	The Contractor shall not employ for the contract works (a) any person that has relationship with any of the officials of the Contractor (i.e., spouses or first blood relations), and (b) any person who retired, within the last two years, as a gazette officer from any department of the government of Sikkim.
F. Additional Conditions	
63. Indemnities	<p>63.1 Each party shall be liable for and indemnify the other Party against losses, expenses and claims for loss or damage to physical property, personal injury, and death caused by his own acts or omissions, subject to the exception defined in Clause 63.3.</p> <p>63.2 Notwithstanding Clause 63.1 above, the Contractor shall be solely responsible for and shall indemnify and hold harmless the Employer from and against all claims, liabilities and costs of action in respect of injury to or both of any person in the employment of the Contractor or any of his Subcontractors subject to exceptions defined in clause 63.3.</p> <p>63.3 The “exceptions” referred to in Clause 63.2 are:</p> <ul style="list-style-type: none"> <li>a. the permanent use or occupation of land by the Works, or any part thereof,</li> <li>b. the right of the Employer to execute the Works, or any part thereof, on, over, under, in or through any land</li> <li>c. damage to property which is the unavoidable result of the execution and completion of the Works, or the remedying of any defects therein, in accordance with the Contract, and</li> </ul>

	<p>d. death or injury to persons or loss of or damage to property resulting from any act or neglect of the Employer, or his agents, servants or other contractors, not being employed by the Contractor, or in respect of any claims, proceedings, damages, costs, charges and expenses in respect thereof or in relation thereto or, whether the injury or damage was contributed to by the Contractor, his servants or agents, such part of the said injury or damage as may be just and equitable having regard to the extent of the responsibility of the Employer, his servants or agents or other contractors for the injury or damage.</p>
64	Deleted
65 Royalties	<p>65.1 Except otherwise stated, the Contractor shall pay all tonnage and other royalty charges and other payments or compensation, if any for getting stone, sand, gravel, clay or other materials required for the works.</p>
66 Third Party Inspection and Testing	<p>66.1 The representative of the concerned independent consultant appointed by the Employer will undertake independent third party inspections and testing for supply and installation pipes and valves used for water supply and sewerage, pumps and motors and all works and any civil structure or material or work as may be applicable and as desired by the Project Manager. The Contractor shall be wholly responsible to make his own arrangements with the approved third party inspection agencies for carrying out the required tests. The Contractor shall be responsible to obtain permission for and provide all facilities to such agency for carrying out such inspections or testing as may be required. The Third Party Inspection charges of the agency only will be paid by the employer and all the other costs for such independent inspection and testing shall be borne by the contractor.</p> <p>66.2 A mutually agreed quality assurance plan with minimum requirements as per Indian Standards will be developed which provides for inspection and certification by the third party inspection agency at specified times.</p> <p>66.3 No material shall be delivered to the site without formal inspection or testing unless otherwise waived in writing by the Project Manager with a certificate issued by the contractor, which is endorsed by the Engineer that the item confirms to the requirement of contract in all respects.</p> <p>66.4 The Employer or his authorized representative may make inspections at any of the manufacturing or shipping points at any time in addition to the schedule provided in this specification at the cost of Employer. However, during such inspection, if it is found that any of the items are not being supplied, manufactured or transported in accordance with the specifications, the contractor shall bear all expenses including fees incurred by the employer in respect of such inspection.</p>

	<p>66.5 The contractor shall perform or make arrangements for all tests when requested by the Employer.</p> <p>66.6 The Contractor shall agree with the Project Manager on the time and place for the inspection of any materials or plant. The Project Manager shall give the contractor not less than 24 hours' notice of his intention to carry out inspection or to attend the tests. If the Project Manager or his duly authorized representative does not attend on the date agreed, the Contractor may, unless otherwise instructed by the Project Manager, proceed with the test reports.</p> <p>66.7 If at the time and place agreed in accordance with as mentioned in the clause 66.4 and 66.6, the materials or Plant if, as a result of the inspection or testing referred to in this Clause, the Project Manger determines that the materials or plant are defective or otherwise not in accordance with the contract, he may reject the materials or plant and shall notify the contractor there of immediately. The notice shall state the Project Manager's observations with reasons. The Contractor shall then promptly make good the defect or replace the same. It the Project Manager so requests, the tests of such material or plant shall be made or repeated under the same terms and conditions. All costs incurred by the Project Manager or the Third Party inspection agency for the inspection of the tests shall be determined by the Project Manager and shall be recoverable from the contractor and may be deducted from any money's due that the Contractor and the Project Manager shall notify the Contractor accordingly.</p> <p>66.8 Any inspection carried out by the Project Manager shall not relieve the contractor of his obligations under the contract.</p>
67 Licenses for Explosives	67.1 The Contractor should take necessary licenses under the current explosive rules to enable him to manufacture and process the quantity of gunpowder / explosive and perform the blasting as necessary according to prevailing rules.
68	Deleted
69 Incomplete or unattended defective works or delays	<p>The Employer has the right to get the uncompleted works done by other competent contractors at the risk and cost of the contractor in the following circumstances:</p> <ul style="list-style-type: none"> <li>a) If the contract is terminated for the reasons attributable to the contractor</li> <li>b) If the Contractor has delayed the work as per the schedule with no justifiable reasons.</li> <li>c) If the Contractor fails to correct any defects in the work within the period stated in the defects notice sent by the Project Manager to the Contractor.</li> </ul>

	<p>d) If the Contractor does not meet any of its obligations within the time frame of the contract specified in section 7 GCC or section 8 PCC.</p>
<p>70 Contractor's General Responsibilities</p>	<p>70.1 The Contractor shall, with due care and diligence, execute and complete the Works and remedy any defects therein accordance with the provisions of the Contract. The Contractor shall provide all superintendence, labour, materials, Plant, Contractor's Equipment and all other things, whether of a temporary or permanent nature, execution, completion and remedying of any defects, so far as the necessity for providing the same is specified in or is reasonably to be inferred from the Contract.</p> <p>The Contractor shall promptly notify the Employer, of any error, omission, fault or other defect in the design of or Specification for the Works which he discovers when reviewing the Contract or executing the Works.</p> <p>70.2 The Contractor shall take full responsibility for the adequacy, stability and safety of all Site operations and methods of construction. Provided that the Contractor shall not be responsible (except as stated hereunder or as may be otherwise agreed) for the design or specification of Permanent Works, not prepared by the Contractor. Where the Contract expressly provides that part of the Permanent Works shall be designed by the Contractor, he shall be fully responsible for that part of such Works, notwithstanding any approval by the Employer.</p> <p>70.3 The Contractor shall provide all necessary superintendence during the execution of the Works and as long as thereafter as the Project Manager may consider necessary for the proper fulfilling of the Contractor's obligations under the Contract. The Contractor, or a competent and authorized representative approved of by the Project Manager, which approval may at any time be withdrawn, shall give his whole time to the superintendence of the Works. Such authorized representative shall receive, on behalf of the Contractor, instructions from the Engineer. If the approval of the representative is withdrawn by the Project Manager, the Contractor shall, as soon as is practicable, having regard to the requirement of replacing him as hereinafter mentioned, after receiving notice of such withdrawal, remove the representative from the Works and shall not thereafter employ him again on the Works in any capacity and shall replace him by another representative approved by the Project Manager.</p> <p>70.4 The Contractor shall be responsible for:</p> <p>(a) the accurate setting-out of the Works in relation to original points, lines and levels of reference given by the Engineer in writing,</p> <p>(b) the correctness, subject as above mentioned, of the position, levels, dimensions and alignment of all parts of the Works, and</p>

	<p>(c) The provision of all necessary instruments, appliances and labour in connection with the foregoing responsibilities.</p> <p>If, any time during the execution of the Works, any error appears in the position, levels, dimensions or alignment of any part of the Works, the Contractor, on being required so to do by the Project Manager, shall, at his own cost, rectify such error to the satisfaction of the Project Manager, unless such error is based on incorrect data supplied in writing by the Project Manager, in which case the Project Manager shall determine an addition to the Contract Price as per the relevant provisions of the contract and shall notify the Contractor accordingly.</p> <p>The checking of any setting-out or of any line by the Project Manager shall not in any way relieve the Contractor of his responsibility for the accuracy thereof and the Contractor shall carefully protect and preserve all bench-marks, sight-rails, pegs and other things used in setting-out the Works.</p>
<p>71 Water for works and workforce</p>	<p>71.1 The contractor at his own expenses should provide water from municipal mains or other sources for the use of work and workmen.</p>
<p>72 Project Manager and Project Manager's representative:</p>	<p>72.1 The Project Manager is the representative of the Employer and the contractor is bound to take all his instructions as that of the employer. The Project Manager shall represent the employer in all dealings with the Contractor concerning the work, including administering contract, certifying payments due to the contractor, issuing and valuing variations, awarding extension of times and valuing compensation events as per the powers delegated to him by the employer and after taking necessary approvals.</p> <p>72.2 The Project Manager's representative who would be appointed to assist the Project Manager would be notified to the Contractor. The Employer / Project Manager may employ any other additional representative for managing this contract.</p> <p>72.3 The Project Manager may from time to time delegate any of his duties and authorities, to his representative, and he may at any time revoke such delegation. Any such delegation or revocation shall be in writing and shall not take effect until copy thereof has been delivered to the Employer and the Contractor.</p> <p>72.4 The Project Manger's representative may appoint any number of persons to assist the Project Manager's representative in carrying out his duties. He shall notify to the Contractor the names, duties and scope of authority of such persons.</p>

<p>73. Alterations, Additions and Omissions</p>	<p>73.1 The Project Manager shall make any variation of the form, quality or quantity of the Works or any part thereof that may, in his opinion, be necessary and for that purpose, or if for any reason it shall, in his opinion appropriate he shall have the authority to instruct the Contractor to do and the Contractor shall do any of the following:</p> <ul style="list-style-type: none"> <li>(a) increase or decrease the quantity of any work included in the Contract,</li> <li>(b) omit any such work</li> <li>(c) change the character or quality or kind of any such work,</li> <li>(d) change the levels, lines, position and dimensions of any part of the Works,</li> <li>(e) execute additional work of any kind necessary for the completion of the Works, or</li> <li>(f) change any specified sequence or timing of construction of any part of the Works.</li> </ul> <p>No such variation shall in any way vitiate or invalidate the Contract, but the effect, if any, of all such variations shall be valued in accordance with relevant provisions of the Contract. Provided that where the issue of an instruction to vary the Works is necessitated by some default of or breach of contract by the Contractor or for which he is responsible, any additional cost attributable to such default shall be borne by the Contractor.</p>
<p>74</p>	<p>Deleted</p>
<p>75. Site Order Book:</p>	<p>75.1 A site order book is to be maintained at site by the contractor for issue of necessary instructions during the site visits. It is binding on the contractor to enforce such instructions and if the compliance of such instructions would have financial implications, the contractor need to inform the Project Manager on the financial implications on executing the instruction, obtain his permission, and sanction before executing such works. No additional payment would be made on the basis of the instructions of the site order alone. The site in charge of the Employer and the Contractor should sign both while issuing the order and after compliance. The site order book needs to be serially numbered. The site order should be maintained by the contractor throughout the work and submitted to the Project Manager before the payment of the final bill.</p>



76. Measurement Book:	76.1 All measurements should be recorded directly in the Measurement Book as per the instructions printed in the Measurement Book.
77. Sikkim State Building & Other Construction Workers Welfare Fund:	77.1 The contractor for this work shall be bound to remit an amount equal to 1 % (one percent) of the value of the work to be done on account of this contract, excluding cost of departmental materials, towards the employer's (Contractor) contribution to Sikkim State Building & Other Construction Workers Welfare Fund as provided in Sikkim Construction Workers Fund. The amount shall be recovered proportionately from the part bills and the final bill for the work and the contractor shall abide by such recoveries.
78. Safety, Security and Protection of the Environment	<p>78.1 Accidents – Hoarding – Lighting – Observations – Watchmen:</p> <p>The contractor shall be responsible for the safety of the labour employed by him and he shall be liable for payment of necessary compensation in the case of accidents as per workers compensation act.</p> <ol style="list-style-type: none"> <li>a) When excavations have been made or obstacles have been put in public through-fares or in places where there is likelihood of accidents, the contractor shall comply with any requirement of law on the subject and shall provide suitable Hoarding- Lighting, watchmen when and where necessary or required by the Project Manager or by any duly constituted authority, for protection of works and safety and convenience of the public or others. In case of excavations on roads, a traffic diversion plan should be made and got approved by the concerned authorities.</li> <li>b) It shall be the contractor's sole responsibility to protect the public and its employees against the accident from any cause and he shall indemnify the Government against any claims for damages for injury to person or property, resulting from any such accidents and he shall, where the provisions of the Workmen's Compensation Act apply, take steps to properly insure against any claims thereafter.</li> <li>c) On the occurrence of an accident which results in the death of any of the workmen employed by the contractor or which is so serious as to be likely to result in the death of any such workmen, the contractor shall within 24 hours of the happening of such accidents, intimate the employer in writing, the fact of such accident. The contractor shall indemnify Government against all loss or damage sustained by the Government resulting directly or indirectly from his failure to give intimation in the manner aforesaid including the penalties or fines if any payable by the Government as a consequence of Government's failure to give notice under the Workmen's</li> </ol>

Compensation Act or otherwise confirm to said Act in regard to such accident.

- d) In the event of an accident in respect of which compensation may become payable under the workmen's Compensation Act VIII of 1923 whether by the Contractor or by the Government as principal it shall be lawful for the Project Manger to retain out of moneys due and payable to the contractor such sum or sums of money as may, the opinion of the Project Manager shall be final in regard or all matters arising under this clause.

78.2. Noise, Disturbance and Pollution:

Works shall be carried out without unreasonable noise and disturbance. The Contractor shall indemnify the Employer from and against any liability for damages on account of noise or other disturbances created while executing the Works and from against all claims, demands, proceedings, damages, costs, charges and expenses whatsoever in regard or in relation to such liability. Necessary permissions as may be required from Pollution Control Board or any other regulatory authority shall have to be obtained by the Contractor for erecting and operating any plant or machinery and for other operations required for the execution of the Works in the Contract.

78.3 Site Sanitation:

The contractor should provide and erect prior to commencement of the work sufficient latrines for the use of workmen, both males and females and should keep the same disinfected and clean all times during the progress of the work and remove the same and restore to original ground on completion of the works.

78.4 HIV/AIDS awareness and prevention program:

It is obligatory as a part of the Contractor to carryout HIV / AIDS awareness and prevention program, and dissemination of information on worksites on risks of sexually transmitted diseases and HIV/AIDS as a part of health and safety measures for those employed under the Contract.

78.5 The Contractor shall comply with all applicable environmental laws and regulations and the Contractor shall

- (a) establish an operational system for managing environmental impacts,
- (b) carry out all of the monitoring and mitigation measures set forth in the Initial Environmental Assessment (IEE) or Environmental Impact Assessment (EIA) and Environment Management Plan (EMP) attached hereto as Appendix 1 (c) allocate the budget required to ensure that such measures are carried out, and the actual costs for the implementation of such measures shall be reimbursed by the Employer

	to the Contractor from Provisional Sum. The Contractor shall submit to the Employer quarterly reports of the carrying out of such measures.
79. Labour	<p>79.1 The contractor shall, unless otherwise provided in the Contract, make his own arrangements for the engagement of all staff and labour, local or other, and for their payment, housing, feeding and transport.</p> <p>79.2 It is mandatory to the contractor to register all the labours he is engaging at site with the concerned authorities.</p> <p>79.3 The Contractor shall, if required by the Project Manager, deliver to the Project Manager a return in detail, in such form and at such intervals as the Project Manager may prescribe, showing the staff and the numbers of the several classes of labour from time to time employed by the Contractor on the Site and such other information as the Project Manager may require.</p>
80. Compliance with Labour Regulations	<p>80.1 During continuance of the contract, the Contractor and his sub-contractors shall abide at all times by all existing labour enactments and rules made there under, regulations, notifications and bye laws of the State or Central government or local authority and any other labour law (including rules), regulations, bye laws that may be passed or notification that may be issued under any labour law in future either by the State or the Central Government or the local authority. Salient features of some of the major labour law that are applicable to construction industry are given below. The contractor shall keep the Employer indemnified in case any action is taken against the Employer by the competent authority on account of contravention of any of the provisions of any Act or Rules made there under, regulations or notifications including amendments. If the Employer is caused to pay or reimburse, such amounts as may be necessary to cause or observe, or for non-observance of the provisions stipulated in the notifications/ bye laws/ Acts/ Rules/ Regulations including amendments, if any, on the part of the Contractor, the Engineer/Employer shall have the right to deduct any money due to the Contractor including his amount of performance security. The Employer/Engineer shall also have right to recover from the Contractor any sum required or estimated to be required for making good the loss or damage suffered by the Employer.</p> <p>80.2 The employees of the Contractor and the Sub Contractor in no case shall be treated as the Employees of the Employer at any point of time.</p> <p>80.3 Salient features of some major labor laws applicable to establishments engaged in building and other construction work:</p> <p>a) Workmen Compensation Act 1923: The Act provides for compensation in case of injury by accident arising out of and during the course of employment.</p>

	<p>b) Payment of Gratuity Act 1972: Gratuity is payable to an employee under the Act on satisfaction of certain conditions on separation if an employee has completed 5 years' service or more or on death the rate of 15 days wages for every completed year of service The Act is applicable to all establishments employing 10 or more employees.</p> <p>c) Employees P.F and Miscellaneous Provision Act 1952: The Act Provides for monthly contributions by the employer plus workers @ 10% or 8.33%. The benefits payable under the Act are:</p> <ul style="list-style-type: none"> <li>• Pension or family pension on retirement or death, as the case maybe</li> <li>• Deposit linked insurance on the death in harness of the worker.</li> <li>• Payment of P.F accumulation on retirement/death etc.</li> </ul> <p>d) Maternity Benefit Act 1951: The Act provides for leave and some other benefits to women employees in case of confinement or miscarriage etc.</p> <p>e) Contract labour (Regulation and Abolition) Act 1970: The Act provides for certain welfare measures to be provided by the Contractor to contract labour and in case the Contractor fails to provide, the same are required to be provided, by the Principal Employer by Law. the Principal Employer is required to take Certificate of Registration and the Contractor is required to take license from the designated officer. The Act is applicable to the establishments or Contractor of Principal Employer if they employ 20 or more contract labour.</p> <p>f) Minimum Wages Act 1948: The Employer is supposed to pay not less than the Minimum Wages fixed by appropriate Government as per provisions of the Act if the employment is a scheduled employment as per the act.</p> <p>g) Payment of Wages Act 1936: It lays down as to by what date the wages are to be paid, when it will be paid and what deductions can be made from the wages of the workers.</p> <p>h) Equal Remuneration Act 1979: The Act provides for payment of equal wages for work of equal nature to male and Female workers and for not making discrimination against Female Employees in the matters of transfers, training and promotions etc.</p> <p>i) Payment of Bonus Act 1965: The Act is applicable to all establishments employing 20 or more employees. The Act provides for payments of annual bonus subject to a minimum of 8.33% of wages and maximum of 20% of wages to employees drawing Rs.3500/ per month or less. The bonus to be paid to employees getting Rs.2500/- per month or above upto Rs.3500/- per month shall be worked out by taking wages as Rs.2500/- per month only. The Act does not apply to certain establishments. The newly set-up establishments are exempted for five years in certain circumstances. Some of the State Governments have reduced the employment size from 20 to 10 for the purpose of applicability of this Act.</p>
--	-------------------------------------------------------------------------------------------------------------------------------------------------------------------------------------------------------------------------------------------------------------------------------------------------------------------------------------------------------------------------------------------------------------------------------------------------------------------------------------------------------------------------------------------------------------------------------------------------------------------------------------------------------------------------------------------------------------------------------------------------------------------------------------------------------------------------------------------------------------------------------------------------------------------------------------------------------------------------------------------------------------------------------------------------------------------------------------------------------------------------------------------------------------------------------------------------------------------------------------------------------------------------------------------------------------------------------------------------------------------------------------------------------------------------------------------------------------------------------------------------------------------------------------------------------------------------------------------------------------------------------------------------------------------------------------------------------------------------------------------------------------------------------------------------------------------------------------------------------------------------------------------------------------------------------------------------------------------------------------------------------------------------------------------------------------------------------------------------------------------------------------------------------------------------------------------------------------------------------------------------------------------------------------------------------------------------------------------------------------------------------------------------------------------------------------------------------------------------------------------------------------------------------------------------------------------------------------------------------------------------------------------------------------------------------------------------------------------------------------------------------------------------------------------------------------------------------------------------------------------------------------------------------------------------------------------------------

- j) Industrial Disputes Act 1947: The Act lays down the machinery and procedure for resolution of Industrial disputes, in what situations a strike or lock – out becomes illegal and what are the requirements for laying off or retrenching the employees or closing down the establishment.
- k) Industrial Employment (Standing Orders) Act 1946: It is applicable to all establishments employing 100 or more workmen (employment size reduced by some of the States and Central Government to 50) The Act provided for laying down rules governing the conditions of employment by the Employer on matters provided in the Act and get the same certified by the designated Authority.
- l) Trade Unions Act 1926: The Act lays down the procedure for registration of trade unions of workmen and employers. The Trade Unions registered under the Act have been given certain immunities from civil and criminal liabilities.
- m) Child Labour (Prohibition and Regulation) Act 1986: The Act prohibits employment of children below 14 years of age in certain occupations and processes and provides for regulation of employment of children in all other occupations and processes. Employment of Child Labour is prohibited in Building and Construction Industry.
- n) Inter-State Migrant Workmen’s (Regulation of Employment and Conditions of Service) Act 1979: The Act is applicable to an establishment which employs 5 or more inter-state migrant workmen through an intermediary (who has recruited workmen in one state for employment in the establishment situated in another state). The Inter-State migrant workmen, in an establishment to which this Act becomes applicable, are required to be provided certain facilities such as housing, medical aid, traveling expenses from home upto establishment and back, etc.
- o) The Building and Other Construction Workers (Regulation of Employment and Conditions of Service) Act 1996 and the Cess Act of 1996: All the Establishments who carry on any building or other construction work and employs 10 or more workers are covered under this Act. All such establishments are required to pay cess at the rate not exceeding 2% of the cost of construction as may be modified by the Government. The Employer of the establishment is required to provide safety measures at the Building or construction work and other welfare measures, such as Canteens, First Aid facilities, Ambulance, housing accommodations for workers near the work place etc. The employer to whom the Act applies has to obtain a registration certificate from the Registering Officer appointed by the Government.
- p) Factories Act 1948: The Act lays down the procedure for approval at plans before setting up a factory, health and safety provisions, welfare provisions, working hours, annual earned leave and rendering information regarding accidents or dangerous occurrences to designated authorities. It is applicable to premises employing 10 persons or more with aide of power or

	<p>20 or more persons without the aid of power engaged in manufacturing process.</p> <p>80.4 Notwithstanding what is given in the above the acts as amended latest shall apply from time to time.</p>
<p>81. Fair Wage Clause:</p>	<p>81.1 The following should be followed in respect of payment of wages to the labour.</p> <ul style="list-style-type: none"> <li>a) The contractor shall pay not less than fair wages to labourers engaged by him on the work. “ Fair Wages” means wage whether for time or piece work notified at the time of inviting Bids for the work and where such wages have not been so notified the wage prescribed by the Central PWD for the District in which the work is done”.</li> <li>b) The contractors shall not withstanding the provisions of any contract to the contrary cause to be paid a fair wage to labourers indirectly engaged on the work including any labour engaged by his subcontractor in connection with the said work as if he labourers had been immediately employed by him.</li> <li>c) In respect of all labour directly or indirectly employed in the works for the performance of the Contractor’s part of this agreement, the contractor shall comply with or cause to be complied with (the Central P W D Contractor’s labour) regulations made by Government in regard to payment of wages, wage period deduction from wages, recovery of wages not paid and deductions unauthorized made, maintenance of wages register, other terms of employment, inspection and submission of periodical returns and all wages cards, publication of scale of wages and returns and all other matters of a like nature.</li> <li>d) The Deputy Programme Director or Subdivision Officer concerned shall have the right to deduct from the moneys due to the contractor and any sum required or estimated to be required for making good the loss suffered by a worker or workers by reasons of non-fulfilment of the conditions of the contract for the benefit of works, non-payment of wages or deductions made from his or their wages which are not justified by their terms of contract or non-observance of the regulations.</li> <li>e) Vis – a Vis the Central Government the Contractor shall be primary liable for all payment to be made under the observance of the regulations aforesaid without prejudice to his right to claim from this subcontractors.</li> <li>f) The regulation aforesaid shall be deemed to be a part of this contract and breach there shall, be a breach of this contract.</li> </ul>
<p>82. Recovery of compensation</p>	<p>In every case in which by virtue of the provisions sub section(1) of section 12, of the workmen’s compensation act 1923, Employer is obliged to pay compensation to a</p>

<p>paid to workmen:</p>	<p>workman employed by the contractor, in execution of the works Employer will recover from the contractor, the amount of compensation so paid ; and without prejudice to the right of the Employer under sub section 2 of section 12 , of the said act Employer shall be at liberty to recover such amount or any part thereof by deducting it from the security deposit or any sum due to the Employer to the contract whether under this contract or otherwise. Employer shall not be bound to contest any claim made against it under sub section (1) Section 12 of the said act except on the written request of the contractor and upon his giving to Employer full security for all costs for which Employer become liable in consequence of contesting such claim.</p>
<p>83. Ensuring Sikkim Labour Protection Act 2005:</p>	<p>In every case in which by virtue of the provisions of Sikkim Labour Protection Act Employer shall be at liberty or to recover such amount or any part thereof by deducting it from the Security Deposit or any sum due by Employer to the contractor under this contract or otherwise.</p> <ol style="list-style-type: none"> <li>1. The contractor must employ local people whose nationality is not in doubt for execution of works in Sikkim.</li> <li>2. The labourers employed by the contractor should be of Indian origin only.</li> <li>3. The Contractor shall obtain a valid certificate of Registration under Sikkim Labour Protection Act 2005 (20 to 2005) and the rules made there under and contractor should abide by all provisions of the act and Rules aforesaid as may be required from time to time regarding wages and other working conditions.</li> <li>4. No labour below the age of 14 years shall be employed on the work and the contractor shall pay not less than fair wages to labourer engaged by him on the work.</li> <li>5. The contractor shall comply with the provisions of the payment of wages act 1936 Minimum Wages Act 1948 Employees Labour (Regulation and Abolition) Act 1970 or the modifications thereof or any other laws relating thereto and the rules made there under from time to time by the state Government.</li> </ol>

## Appendix-1 Environmental Monitoring Plan

(Deleted)



## Appendix-2 Environmental Management Plan

Field	Anticipated Impact	Mitigation Measures	Responsible for Mitigation	Monitoring of Mitigation
Sources of Materials	Extraction of rocks and material may cause ground instability	(i) Use quarry sites and sources permitted by government;  (ii) Verify suitability of all material sources and obtain approval of GSCDL  (iii) Submit to GSCDL on a monthly basis documentation of sources of materials.	Construction Contractor	Construction Contractor documentation
Air Quality	Emissions from construction vehicles, equipment, and machinery used for excavation and construction resulting to dusts and increase in concentration of vehicle-related pollutants such as carbon monoxide, sulfur oxides, particulate matter, nitrous oxides, and hydrocarbons)	(i) Consult with GSCDL on the designated areas for stockpiling of clay, soils, gravel, and other construction materials;  (ii) Damp down exposed soil and any stockpiled on site by spraying with water when necessary during dry weather;  (iii) Bring materials (aggregates) as and when required;  (iv) Use tarpaulins to cover sand and other loose material when transported by vehicles;  (v) Fit all heavy equipment and machinery with air pollution control devices which are operating correctly; and  (vi) Clean wheels and undercarriage of vehicles	Construction Contractor	(i) Location of stockpiles;  (ii) Complaints from sensitive receptors;  (iii) Heavy equipment and machinery with air pollution control devices;  (iv) Ambient air for Respirable particulate matter (RPM) and suspended particulate matter (SPM);  (v) Vehicular emissions such as Sulphur dioxide (SO <sub>2</sub> ), nitrous oxides (NO <sub>x</sub> ), carbon monoxide (CO),

Field	Anticipated Impact	Mitigation Measures	Responsible for Mitigation	Monitoring of Mitigation
		prior to leaving construction site.		and hydrocarbons
Surface water quality	Mobilization of settled silt materials, run-off from stockpiled materials, and chemical contamination from fuels and lubricants during construction works can contaminate nearby surface water quality.	<p>(i) Avoid stockpiling of earth fill especially during the monsoon season unless covered by tarpaulins or plastic sheets;</p> <p>(ii) Prioritize re-use of excess spoils and materials in the construction works. If spoils will be disposed, consult with GSCDL on designated disposal areas;</p> <p>(iii) Install temporary silt traps or sedimentation basins along the drainage leading to the water bodies;</p> <p>(iv) Place storage areas for fuels and lubricants away from any drainage leading to water bodies;</p> <p>(v) Dispose any wastes generated by construction activities in designated sites; and</p> <p>(vi) Conduct surface quality inspection according to the Environmental Management Plan (EMP).</p>	Construction Contractor	<p>(i) Areas for stockpiles, storage of fuels and lubricants and waste materials;</p> <p>(ii) Number of silt traps installed along drainages leading to water bodies;</p> <p>(iii) Records of surface water quality inspection;</p> <p>(iv) Effectiveness of water management measures;</p> <p>(v) For inland water: suspended solids, oil and grease, biological oxygen demand (BOD), and coliforms.</p>
Noise Levels	Increase in noise level due to earth-moving and excavation equipment, and the transportation of	(i) Plan activities in consultation with GSCDL so that activities with the greatest potential to generate noise are	Construction Contractor	(i) Complaints from sensitive receptors;

Field	Anticipated Impact	Mitigation Measures	Responsible for Mitigation	Monitoring of Mitigation
	equipment, materials, and people	<p>conducted during periods of the day which will result in least disturbance;</p> <p>(ii) Provide prior information to the local public about the work schedule;</p> <p>(iii) Require horns not be used unless it is necessary to warn other road users or animals of the vehicle's approach;</p> <p>(iv) Minimize noise from construction equipment by using vehicle silencers, fitting jackhammers with noise-reducing mufflers, and portable street barriers the sound impact to surrounding sensitive receptor; and</p> <p>(vi) Maintain maximum sound levels not exceeding 80 decibels (dB) when measured at a distance of 10 m or more from the vehicle/s.</p>		<p>(ii) Use of silencers in noise-producing equipment and sound barriers;</p> <p>(iii) Equivalent day and night time noise levels</p>
Socio-Economic – Employment and income	Generation of contractual employment and increase in local revenue	<p>(i) Employ at least 50% of the labour force, or to the maximum extent, local persons within the 2-km immediate area if manpower is available; and</p> <p>(ii) Secure construction materials from local market.</p>	Construction Contractor	<p>(i) Employment records;</p> <p>(ii) records of sources of materials</p>
Occupational Health and Safety	Occupational hazards which can arise during work	(i) Develop and implement site-specific Health and Safety (H and S) Plan which will include measures such	Construction Contractor	(i) Site-specific Health and

Field	Anticipated Impact	Mitigation Measures	Responsible for Mitigation	Monitoring of Mitigation
		<p>as: (a) excluding public from the site; (b) ensuring all workers are provided with and use Personal Protective Equipment; (c) H and S Training for all site personnel; (d) documented procedures to be followed for all site activities; and (e) documentation of work-related accidents;</p> <p>(ii) Ensure that qualified first-aid can be provided at all times. Equipped first-aid stations shall be easily accessible throughout the site;</p> <p>(iii) Provide medical insurance coverage for workers;</p> <p>(iv) Secure all installations from unauthorized intrusion and accident risks;</p> <p>(v) Provide supplies of potable drinking water;</p> <p>(vi) Provide clean eating areas where workers are not exposed to hazardous or noxious substances;</p> <p>(vii) Provide H and S orientation training to all new workers to ensure that they are apprised of the basic site rules of work at the site, personal protective protection, and preventing injuring to fellow workers;</p>		<p>Safety (H and S) Plan;</p> <p>(ii) Equipped first-aid stations;</p> <p>(iii) Medical insurance coverage for workers;</p> <p>(iv) Number of accidents;</p> <p>(v) Supplies of potable drinking water;</p> <p>(vi) Clean eating areas where workers are not exposed to hazardous or noxious substances;</p> <p>(vii) record of H and S orientation trainings</p> <p>(viii) personal protective equipments;</p> <p>(ix) % of moving equipment outfitted with audible back-up alarms;</p> <p>(xi) sign boards for hazardous areas such as energized electrical</p>

Field	Anticipated Impact	Mitigation Measures	Responsible for Mitigation	Monitoring of Mitigation
		<p>(viii) Provide visitor orientation if visitors to the site can gain access to areas where hazardous conditions or substances may be present. Ensure also that visitor/s do not enter hazard areas unescorted;</p> <p>(ix) Ensure the visibility of workers through their use of high visibility vests when working in or walking through heavy equipment operating areas;</p> <p>(x) Ensure moving equipment is outfitted with audible back-up alarms;</p> <p>(xi) Mark and provide sign boards for hazardous areas such as energized electrical devices and lines, service rooms housing high voltage equipment, and areas for storage and disposal. Signage shall be in accordance with international standards and be well known to, and easily understood by workers, visitors, and the general public as appropriate; and</p> <p>(xii) Disallow worker exposure to noise level greater than 85 dBA for a duration of more than 8 hours per day without hearing protection. The use of hearing protection shall be enforced actively.</p>		<p>devices and lines, service rooms housing high voltage equipment, and areas for storage and disposal.</p>

Field	Anticipated Impact	Mitigation Measures	Responsible for Mitigation	Monitoring of Mitigation
Quarry Sites and Borrow Pits	Extraction of approximately 8575 m3 of clay, 476.4 m3 of sand, 22282 m3 of stones, 952.8 m3 of coarse aggregates, and loose materials other than stones can cause disruption of natural land contours and vegetation resulting in accelerated erosion, landslides, disturbance in natural drainage patterns, sedimentation/siltation of surface waters, and water pollution.	<p>(i) Verify suitability of all material sources and obtain approval of GSCDL;</p> <p>(ii) Prioritize government-approved quarries and borrow pits;</p> <p>(iii) Obtain approval of GSCDL if new quarries and borrow sites are necessary;</p> <p>(iv) Obtain approval of GSCDL if extracting rocks, gravel, and sand from small rivers or streams is necessary. The extraction points shall be spread out along the length of the river to minimize disruption in river flow and to prevent instability to embankments. Local residents and water users shall be consulted to ensure that irrigation intakes, bunds, and local fishing are not adversely impacted; and</p> <p>(v) Request GSCDL to report in writing that the necessary environmental restoration work has been adequately performed before acceptance of work.</p>	Construction contractor	<p>(i) List of approved quarry sites and borrow pits;</p> <p>(ii) GSCDL/PDMC report in writing that all necessary environmental restoration work has been adequately performed before acceptance of work.</p>
Work Camps	Temporary air and noise pollution from machine operation, water pollution from storage and use of fuels, oils, solvents, and lubricants	(i) Consult with GSCDL before locating project offices, sheds, and construction plants;	Construction Contractor	<p>(i) Complaints from sensitive receptors;</p> <p>(ii) Water and sanitation</p>

Field	Anticipated Impact	Mitigation Measures	Responsible for Mitigation	Monitoring of Mitigation
		<p>(ii) Minimize removal of vegetation and disallow cutting of trees;</p> <p>(iii) Provide water and sanitation facilities for employees;</p> <p>(iv) Prohibit employees from poaching wildlife and cutting of trees for firewood;</p> <p>(v) Train employees in the storage and handling of materials which can potentially cause soil contamination;</p> <p>(vi) Recover used oil and lubricants and reuse or remove from the site;</p> <p>(vii) Manage solid waste according to the following preference hierarchy: reuse, recycling and disposal to designated areas;</p> <p>(viii) Remove all wreckage, rubbish, or temporary structures which are no longer required; and</p> <p>(ix) Request GSCDL to report in writing that the camp has been vacated and restored to pre-project conditions before acceptance of work.</p>		<p>facilities for employees; and</p> <p>(iii) GSCDL/PDMC report in writing that the camp has been vacated and restored to pre-project conditions</p>
Social and Cultural Resources –	Risk of archaeological chance finds	(i) Strictly follow the protocol for chance finds in any excavation work;	Construction Contractor	Records of chance finds

Field	Anticipated Impact	Mitigation Measures	Responsible for Mitigation	Monitoring of Mitigation
Chance Finds		<p>(ii) Request GSCDL or any authorized person with archaeological/historical field training to observe excavation;</p> <p>(iii) Stop work immediately to allow further investigation if any finds are suspected; and</p> <p>(iv) Inform GSCDL if a find is suspected, and take any action they require ensuring its removal or protection in situ.</p>		



## Section 9 - Contract Forms

This Section contains forms which, once completed, will form part of the Contract. The forms for Performance Security and Advance Payment Security, when required, shall only be completed by the successful Bidder after contract award.

**Letter of Acceptance**

**---- on letterhead paper of the Employer ----**

..... **date.** .....

To: ..... **name and address of the Contractor** .....

Subject:..... **Notification of Award Contract No.** .....

Dear Sirs

This is to notify you that your Bid dated . . . . **date** . . . . for  
.....  
Gangtok, Sikkim or the Contract Price of Rupees .....  
....., **amount in numbers and words** as corrected and modified in accordance with the  
Instructions to Bidders\* is hereby accepted by our Agency.

We accept/ do not accept that .....be appointed as  
the Adjudicator \*\*.

We note that as per bid, you do not intend to subcontract any component of work.

OR

We note that as per bid, you propose to employ M/s ..... as sub-contractor  
for executing .....

*[delete whichever is not applicable]*

You are hereby requested to furnish the Performance Security, plus additional security for unbalance bids in terms of ITB clause 43.1, in the form detailed in Para 37.5 of ITB for an amount of INR. . . . .  
. . . . . within 15 days of the receipt of this letter of acceptance valid up to 28 days from the date of expiry of Defects Liability Period i.e.: unto . . . . . and sign the contract, failing which action as stated in Para 43.2 of ITB will be taken.

We have reviewed the construction methodology submitted by you along with the bid in response to section IV and our comments are given in the attachment. You are requested to submit a revised Program including environmental management plan as per Clause 25 of General Conditions of Contract within 14 days of receipt of this letter.

Yours Faithfully

Authorized Signature:

Name and Title of Signatory:

Name of Agency:

---

\* - delete "corrected and" or "and modified" if only one of these actions applies. Delete "as corrected and modified in accordance with the Instructions to Bidders" if corrections or modifications have not been effected.

\*\* - to be used only if the Contractor disagrees in his Bid with the Adjudicator proposed by the Employer".

## Contract Agreement

THIS AGREEMENT made the . . . . .day of . . . . ., . . . . ., between Chief Executing Officer, GSCDL, Sokaythang, Gangtok-737101, Sikkim (India) (here in after “the Employer”), of the one part, and . . . . . name of the Contractor. . . . .(hereinafter “the Contractor”), of the other part:

WHEREAS the Employer desires that the Works known as “**Improvement of 12 KM (approx.) Pedestrian Walkway/ Footpath from Baluwakhani (Vajra Cinema Hall) to Ranipool, Gangtok, East Sikkim including Defect Liability Period of One Year**”, should be executed by the Contractor, and has accepted a Bid by the Contractor for the execution and completion of these Works and the remedying of any defects therein,

The Employer and the Contractor agree as follows:

1. ***In this Agreement words and expressions shall have the same meanings as are respectively assigned to them in the Contract documents referred to.***
2. ***The following documents shall be deemed to form and be read and construed as part of this Agreement. This Agreement shall prevail over all other Contract documents.***
  - a) the Letter of Acceptance
  - b) Letters of Technical Bid and Price Bid
  - c) The Addenda Nos . . . . . *insert addenda numbers if any.* . . . . .
  - d) the Particular Conditions
  - e) the General Conditions;
  - f) the Specification
  - g) the Drawings; and
  - h) the completed Schedules,
3. ***In consideration of the payments to be made by the Employer to the Contractor as indicated in this Agreement, the Contractor hereby covenants with the Employer to execute the Works and to remedy defects therein in conformity in all respects with the provisions of the Contract.***
4. ***The Employer hereby covenants to pay the Contractor in consideration of the execution and completion of the Works and the remedying of defects therein, the Contract Price or such other sum as may become payable under the provisions of the Contract at the times and in the manner prescribed by the Contract.***

***IN WITNESS*** whereof the parties hereto have caused this Agreement to be executed in accordance with the laws of Sikkim . . . . .on the day, month and year indicated above.

Signed by .....

for and on behalf of the Employer

in the presence of:

Witness, Name, Signature, Address, Date

Signed by .....

for and on behalf the Contractor

in the presence of:

Witness, Name, Signature, Address, Date

## Unconditional Performance Security

*Bank's Name, and Address of Issuing Branch or Office*

**Beneficiary:**

**Name of the Employer: Gangtok Smart City Development Limited represented by the Chief Executing Officer, Sokaythang, Gangtok-737102, Sikkim (India)**

**Date:**

**Performance Guarantee No.:**

We have been informed that . . . . . name of the Contractor. . . . . (here in after called "the Contractor") has entered into Contract No. . . . . reference number of the Contract. . . . . dated . . . . . . .with you, for the **"Improvement of 12 KM (approx.) Pedestrian Walkway/ Footpath from Baluwakhani (Vajra Cinema Hall) to Ranipool, Gangtok, East Sikkim including Defect Liability Period of One Year"**, (hereinafter called "the Contract").

Furthermore, we understand that, according to the conditions of the Contract, an irrevocable and unconditional performance guarantee is required.

At the request of the Contractor, we . . . . . *name of the Bank*. . . . . hereby unconditionally and irrevocably undertake to pay you any sum or sums not exceeding in total an amount of . . . . . *name of the currency and amount in figures*. . . . . (*amount in words*. . . . . ) such sum being payable in the types and proportions of currencies in which the Contract Price is payable, upon receipt by us of your first demand in writing accompanied by a written statement stating that the Contractor is in breach of its obligation(s) under the Contract, and without cavil & arguments without your needing to prove or to show grounds for your demand or the sum specified therein.

This guarantee shall expire, no later than the . . . . . Day of . . . . . *Insert the date twenty-eight days after the defect liability period*. . . . . , . . . . . , and any demand for payment under it must be received by us at this office on or before that date.

*The Guarantor agrees to a one-time extension of this guarantee for a period not to exceed [one year], in response to the Employer's written request for such extension, such request to be presented to the Guarantor before the expiry of the guarantee*

.....  
**Seal of Bank and Signature(s)**

## Advance Payment Security (Unconditional)

*Bank's Name, and Address of Issuing Branch or Office*

**Beneficiary:**

**Name of the Employer: Gangtok Smart City Development Limited represented by the Chief Executing Officer, Sokaythang, Gangtok-737102, Sikkim (India)**

**Date:**

**Advance Payment Guarantee No.:**

We have been informed that . . . . . name of the Contractor. . . . . (hereinafter called "the Contractor") has entered into Contract No. . . . . reference number of the Contract. . . . . dated . . . . . . with you, for the **"Improvement of 12 KM (approx.) Pedestrian Walkway/ Footpath from Baluwakhani (Vajra Cinema Hall) to Ranipool, Gangtok, East Sikkim including Defect Liability Period of One Year"**, (hereinafter called "the Contract").

Furthermore, we understand that, according to the Conditions of the Contract, an advance payment in the sum . . . . . **name of the currency and amount in figures. . . . . ( . . . . . amount in words. . . . . )** is to be made against an advance payment guarantee.

At the request of the Contractor, we . . . . . **name of the Bank. . . . .** hereby unconditionally and irrevocably undertake to pay you any sum or sums not exceeding in total an amount of . . . . . **name of the currency and amount in figures\*. . . . . ( . . . . . amount in words. . . . . )** upon receipt by us of your first demand in writing accompanied by a written statement stating that the Contractor is in breach of its obligation under the Contract because the Contractor used the advance payment for purposes other than the costs of mobilization in respect of the Works.

It is a condition for any claim and payment under this guarantee to be made that the advance payment referred to above must have been received by the Contractor on its account number . . . . . **Contractor's account number. . . . . at . . . . . name and address of the Bank. . . . .**

The maximum amount of this guarantee shall be progressively reduced by the amount of the advance payment repaid by the Contractor as indicated in copies of interim statements or payment certificates which shall be presented to us. This guarantee shall expire upon our receipt of a copy of the payment certificate indicating that hundred (100) percent mobilization advance has been recovered. This guarantee will not be subjected to any cavil or arguments.

*The Guarantor agrees to a one-time extension of this guarantee for a period not to exceed [one year], in response to the Employer's written request for such extension, such request to be presented to the Guarantor before the expiry of the guarantee*

..... **Seal of Bank and Signature(s)** .....



## Unconditional Bank Guarantee in Lieu of Retention Money

**To: Gangtok Smart City Development Limited represented by the Chief Executing Officer, Sokaythang, Gangtok-737102, Sikkim (India)**

WHEREAS \_\_\_\_\_ [name and address of contractor] (hereinafter called the "Contractor") has undertaken, in pursuance of Contract No. \_\_\_\_\_ dated \_\_\_\_\_ for **Improvement of 12 KM (approx.) Pedestrian Walkway/ Footpath from Baluwakhani (Vajra Cinema Hall) to Ranipool, Gangtok, East Sikkim including Defect Liability Period of One Year**, (herein after called the "Contract".);

AND WHEREAS IT HAS BEEN AGREED BY YOU IN THE SAID contract that the Contractor has option to replace the Retention Money with an irrevocable and unconditional Bank Guarantee, in instalments of \_\_\_\_\_ (*indicate the value*) from a Bank acceptable to you as security for compliance with contractor's obligations in accordance with the contract (Sub-clause 45.2 of Particular Conditions of Contract).

AND WHEREAS the Contractor has opted to replace the retention money with an irrevocable and unconditional Bank Guarantee;

NOW THEREFORE we hereby affirm that we are the Guarantor and responsible to you, on behalf of the Contractor, up to a total of \_\_\_\_\_ [*amount of Guarantee in figures*], \_\_\_\_\_ [*amount in words*], # such sum being payable in the types and proportions of currencies in which the Contract Price is payable, and we undertake to pay you, upon your first written demand and without cavil or argument, any sum or sums within the limits of \_\_\_\_\_ [amount of Guarantee] as aforesaid without your needing to prove or to show grounds or reasons for your demand for the sum specified therein.

We hereby waive the necessity of your demanding the said debt from the Contractor before presenting us with the demand.

We further agree that no change or addition to or other modification of the terms of the Contract or of the Works to be performed there under or of any of the Contract documents which may be made between

you and the Contractor shall in any way release us from any liability under this guarantee, and we hereby waive notice of any such change, addition or modification.

This guarantee shall be valid till the 'Project Manager' certifies repayment of retention money in accordance with Sub-clause 45.2 of Particular Conditions of Contract i.e., upto .....

SIGNATURE AND SEAL OF THE GUARANTOR

Name of the Bank: \_\_\_\_\_

Address: \_\_\_\_\_

Date: \_\_\_\_\_

---

# *An amount is to be inserted by the Guarantor, representing the amount specified in the Contract, and denominated either in the currency(ies) of the Contract or in a freely convertible currency acceptable to the Employer.*

**(Name of the Project): Improvement of 12 KM (approx.) Pedestrian Walkway/ Footpath from Baluwakhani (Vajra Cinema Hall) to Ranipool, Gangtok, East Sikkim including Defect Liability Period of One Year**

(Declaration regarding customs/excise duty exemption for materials/ goods)

(Bidder's Name and Address)

To:

Chief Executing Officer,

GSCDL,

Sokaythang,

Gangtok-737102,

Sikkim (India).

Dear Sir:

Re: Improvement of 12 KM (approx.) Pedestrian Walkway/ Footpath from Baluwakhani (Vajra Cinema Hall) to Ranipool, Gangtok, East Sikkim including Defect Liability Period of One Year,

Certificate for Procurement of Materials/ Goods

1. We confirm that we are solely responsible for obtaining customs/excise duty waivers which we have considered in our bid and in case of failure to receive such waivers for reasons whatsoever, the Employer will not compensate us.
2. We are furnishing below the information required by the Employer for issue of the necessary certificates in terms of the Government of India Central Excise Notification No. ----- and Customs Notification No.-----.
3. The materials/goods for which certificates are required are as under:

Items	Quantity	Value	State whether it will be procured locally or imported [if so from which country]	Remarks regarding justification for the quantity and their usage in works
Materials/Goods				
[a] Bitumen				
[b] Others				
[a]				
[b]				
[c]				
[d]				

4. We agree that no modification to the above list is permitted after bids are opened.
5. We agree that the certificate will be issued only to the extent considered reasonable by the Employer for the work, based on the Bill of Quantities and the construction programme and methodology as furnished by us along with the bid.
6. We confirm that the above goods will be exclusively used for the construction of the above work.

7. Any delay in procurement of the goods/materials as a result of the above shall not be a cause for granting any extension of time.

Date: \_\_\_\_\_

(Signature) \_\_\_\_\_

Place: \_\_\_\_\_

(Printed Name)

(Designation) \_\_\_\_\_

(Common Seal) \_\_\_\_\_

### Appendix 1

Field	Anticipated Impact	Mitigation Measures	Responsible for Mitigation	Monitoring of Mitigation
Sources of Materials	Extraction of rocks and material may cause ground instability	(i) Use quarry sites and sources permitted by government;; (ii) Verify suitability of all material sources and obtain approval of Gangtok Smart City Development Limited (GSCDL)and (iii) Submit to GSCDL on a monthly basis documentation of sources of materials.	Construction Contractor	Construction Contractor documentation
Air Quality	Emissions from construction vehicles, equipment, and machinery used for excavation and construction resulting to dusts and increase in concentration of vehicle-related pollutants such as carbon monoxide, sulfur oxides, particulate matter, nitrous oxides, and hydrocarbons)	(i) Consult with GSCDL on the designated areas for stockpiling of clay, soils, gravel, and other construction materials; (ii) Excavate the SRs foundations at the same time as the access roads (if needed) are built so that dug material is used immediately, avoiding the need to stockpile on site; (iii) Damp down exposed soil and any stockpiled on site by spraying with water when necessary during dry weather; (iv) Bring materials (aggregates) as and when required; (v) Use tarpaulins to cover sand and other loose material when transported by vehicles; (vi) Fit all heavy equipment and machinery with air pollution control	Construction Contractor	(i) Location of stockpiles; (ii) Complaints from sensitive receptors; (iii) Heavy equipment and machinery with air pollution control devices; (iv) Ambient air for respirable particulate matter (RPM) and suspended particulate

Field	Anticipated Impact	Mitigation Measures	Responsible for Mitigation	Monitoring of Mitigation
		<p>devices which are operating correctly; and</p> <p>(vii) Clean wheels and undercarriage of vehicles prior to leaving construction site.</p>		<p>matter (SPM);</p> <p>(v) Vehicular emissions such as Sulphur dioxide (SO<sub>2</sub>), nitrous oxides (NO<sub>x</sub>), carbon monoxide (CO), and hydrocarbons</p>
Surface water quality	<p>Mobilization of settled silt materials, run-off from stockpiled materials, and chemical contamination from fuels and lubricants during construction works can contaminate nearby surface water quality.</p>	<p>(i) Avoid stockpiling of earth fill especially during the monsoon season unless covered by tarpaulins or plastic sheets;</p> <p>(ii) Prioritize re-use of excess spoils and materials in the construction works. If spoils will be disposed, consult with GSCDL on designated disposal areas;</p> <p>(iii) Install temporary silt traps or sedimentation basins along the drainage leading to the water bodies;</p> <p>(iv) Place storage areas for fuels and lubricants away from any drainage leading to water bodies;</p> <p>(v) Dispose any wastes generated by construction activities in designated sites; and</p>	Construction Contractor	<p>(i) Areas for stockpiles, storage of fuels and lubricants and waste materials;</p> <p>(ii) Number of silt traps installed along drainages leading to water bodies;</p> <p>(iii) Records of surface water quality inspection;</p> <p>(iv) Effectiveness of water</p>

Field	Anticipated Impact	Mitigation Measures	Responsible for Mitigation	Monitoring of Mitigation
		(vi) Conduct surface quality inspection according to the Environmental Management Plan (EMP).		management measures;  (v) For inland water: suspended solids, oil and grease, biological oxygen demand (BOD), and coliforms.
Noise Levels	Increase in noise level due to earth-moving and excavation equipment, and the transportation of equipment, materials, and people	<p>(i) Plan activities in consultation with GSCDL so that activities with the greatest potential to generate noise are conducted during periods of the day which will result in least disturbance;</p> <p>(ii) Provide prior information to the local public about the work schedule;</p> <p>(iii) Require horns not be used unless it is necessary to warn other road users or animals of the vehicle's approach;</p> <p>(iv) Ensure that there are no old and sensitive buildings that may come under risk due to the use of pneumatic drills; if there is risk, cut the rocks manually by chiseling;</p> <p>(v) Minimize noise from construction equipment by using vehicle silencers, fitting jackhammers with noise-reducing</p>	Construction Contractor	<p>(i) Complaints from sensitive receptors;</p> <p>(ii) Use of silencers in noise-producing equipment and sound barriers;</p>



Field	Anticipated Impact	Mitigation Measures	Responsible for Mitigation	Monitoring of Mitigation
		<p>mufflers, and portable street barriers the sound impact to surrounding sensitive receptor; and</p> <p>(vi) Maintain maximum sound levels not exceeding 80 decibels (dB) when measured at a distance of 10 m or more from the vehicle/s.</p>		
Landscape and Aesthetics	Solid wastes as well as excess construction materials	<p>(i) Avoid stockpiling of excess excavated soils;</p> <p>(ii) Avoid disposal of any debris and waste soils in the forest areas and in or near water bodies/rivers;</p> <p>(iii) Coordinate with GMC for beneficial uses of excess excavated soils or immediately dispose to designated areas;</p> <p>(iv) Manage solid waste according to the following preference hierarchy: reuse, recycling and disposal to designated areas; and (v) Request GSCDL/PDMC to report in writing that the necessary environmental restoration work has been adequately performed before acceptance of work.</p>	Construction Contractor	<p>(i) Complaints from sensitive receptors;</p> <p>(ii) GSCDL/PDMC to report in writing that the necessary environmental restoration work has been adequately performed before acceptance of work.</p>
Accessibility	Traffic problems and conflicts near project locations and haul road	<p>(i) Plan pipeline work in consultation with the traffic police;</p> <p>(ii) Conduct work during light traffic;</p>	Construction Contractor	<p>(i) Traffic Management measures;</p> <p>(ii) Complaints</p>

Field	Anticipated Impact	Mitigation Measures	Responsible for Mitigation	Monitoring of Mitigation
		<p>(iii) Plan work such that trench excavation, pipe laying, and refilling including compacting, at a stretch is completed in a minimum possible time;</p> <p>(iv) Provide for immediate consolidation of backfilling material to desired compaction to avoid future settlement risk - this will allow immediate road restoration and therefore will minimize disturbance to the traffic movement;</p> <p>(v) Do not close the road completely, ensure that work is conducted onto edge of the road; allow traffic to move on one line;</p> <p>(vi) In unavoidable circumstances of road closure, provide alternative routes, and ensure that public is informed about such traffic diversions;</p> <p>(vii) In case of closure of main roads, provide information to the public through media – daily newspapers and local cable television (TV) services, about the need and schedule of road closure, and alternative routes;</p> <p>(viii) At all work sites public information/caution boards shall be provided – information shall inter-alia include: project name, cost and schedule; executing agency and contractor details; nature and schedule of work at that</p>		<p>from sensitive receptors;</p> <p>(iii) Number of signages placed at subproject location.</p>

Field	Anticipated Impact	Mitigation Measures	Responsible for Mitigation	Monitoring of Mitigation
		road/locality; traffic diversion details, if any; entry restriction information; competent official's name and contact for public complaints.		
Socio-Economic – Income.	Impede the access of residents and customers to nearby shops	<p>(i) Leave space for access between mounds of excavated soil;</p> <p>(ii) Provide wooden planks/footbridges for pedestrians and metal sheets for vehicles to allow access across trenches to premises where required;</p> <p>(iii) Consult affected businesspeople to inform them in advance when work will occur;</p> <p>(iv) Provide prior public information about the work schedule in particular locality and the traffic diversions/changes in any – information shall disseminated through local papers and cable television services;</p> <p>(v) Provide sign/caution/warning boards at work site indicating work schedule and traffic information; prevent public entry into work sites through barricading and security; and</p> <p>(vi) Provide sign boards for pedestrians to inform nature and duration of construction works and contact numbers for concerns/complaints.</p>	Construction Contractor	<p>(i) Complaints from sensitive receptors;</p> <p>(ii) Number of walkways, signages, and metal sheets placed at subproject location.</p>

Field	Anticipated Impact	Mitigation Measures	Responsible for Mitigation	Monitoring of Mitigation
Socio-Economic - Employment	Generation of contractual employment and increase in local revenue	(i) Employ at least 50% of the labour force, or to the maximum extent, local persons if manpower is available; and  (ii) Secure construction materials from local market.	Construction Contractor	(i) Employment records;  (ii) records of sources of materials
Occupational Health and Safety	Occupational hazards which can arise during work	(i) Implement measures such as: (a) excluding public from the site; (b) ensuring all workers are provided with and use Personal Protective Equipment; (c) H and S Training for all site personnel; (d) documented procedures to be followed for all site activities; and (e) documentation of work-related accidents;  (ii) Ensure that qualified first-aid can be provided at all times. Equipped first-aid stations shall be easily accessible throughout the site;  (iii) Secure all installations from unauthorized intrusion and accident risks;  (iv) Provide supplies of potable drinking water;  (v) Provide clean eating areas where workers are not exposed to hazardous or noxious substances;  (vi) Provide H and S orientation training to all new workers to ensure	Construction Contractor	(i) Site-specific Health and Safety (H and S) Plan;  (ii) Equipped first-aid stations;  (iii) Number of accidents;  (iv) Supplies of potable drinking water;  (vi) Clean eating areas where workers are not exposed to hazardous or noxious substances;  (vii) record of H and S

Field	Anticipated Impact	Mitigation Measures	Responsible for Mitigation	Monitoring of Mitigation
		<p>that they are apprised of the basic site rules of work at the site, personal protective protection, and preventing injuring to fellow workers;</p> <p>(vii) Provide visitor orientation if visitors to the site can gain access to areas where hazardous conditions or substances may be present. Ensure also that visitor/s do not enter hazard areas unescorted;</p> <p>(viii) Ensure the visibility of workers through their use of high visibility vests when working in or walking through heavy equipment operating areas;</p> <p>(ix) Ensure moving equipment is outfitted with audible back-up alarms;</p> <p>(x) Mark and provide sign boards for hazardous areas such as energized electrical devices and lines, service rooms housing high voltage equipment, and areas for storage and disposal. Signage shall be in accordance with international standards and be well known to, and easily understood by workers, visitors, and the general public as appropriate; and</p> <p>(xi) Disallow worker exposure to noise level greater than 85 dB for a duration of more than 8 hours per day without hearing protection. The</p>		<p>orientation trainings</p> <p>(viii) personal protective equipments;</p> <p>(ix) % of moving equipment outfitted with audible back-up alarms;</p> <p>(x) sign boards for hazardous areas such as energized electrical devices and lines, service rooms housing high voltage equipment, and areas for storage and disposal.</p>

Field	Anticipated Impact	Mitigation Measures	Responsible for Mitigation	Monitoring of Mitigation
		use of hearing protection shall be enforced actively.		
Community Health and Safety.	Traffic accidents and vehicle collision with pedestrians during material and waste transportation	<p>The construction contractor will be required to:</p> <ul style="list-style-type: none"> <li>(i) Plan routes to avoid times of peak-pedestrian activities.</li> <li>(ii) Liaise with GSCDL in identifying risk areas on route cards/maps.</li> <li>(iii) Maintain regularly the vehicles and use of manufacturer-approved parts to minimize potentially serious accidents caused by equipment malfunction or premature failure.</li> <li>(iv) Provide road signs and flag persons to warn of dangerous conditions, in case of location near the road.</li> </ul>	Construction Contractor	<ul style="list-style-type: none"> <li>(i) Traffic Management Measures;</li> <li>(ii) Complaints from sensitive receptors</li> </ul>
Work Camps	Temporary air and noise pollution from machine operation, water pollution from storage and use of fuels, oils, solvents, and lubricants	<ul style="list-style-type: none"> <li>(i) Consult with GSCDL before locating project offices, sheds, and construction plants;</li> <li>(ii) Minimize removal of vegetation and disallow cutting of trees;</li> <li>(iii) Provide water and sanitation facilities for employees;</li> <li>(iv) Prohibit employees from poaching wildlife and cutting of trees for firewood;</li> </ul>	Construction Contractor	<ul style="list-style-type: none"> <li>(i) Complaints from sensitive receptors;</li> <li>(ii) Water and sanitation facilities for employees; and</li> <li>(iii) GSCDL/PDM C report in writing that the camp has</li> </ul>

Field	Anticipated Impact	Mitigation Measures	Responsible for Mitigation	Monitoring of Mitigation
		<p>(v) Train employees in the storage and handling of materials which can potentially cause soil contamination;</p> <p>(vi) Recover used oil and lubricants and reuse or remove from the site;</p> <p>(vii) Manage solid waste according to the following preference hierarchy: reuse, recycling and disposal to designated areas;</p> <p>(viii) Remove all wreckage, rubbish, or temporary structures which are no longer required; and</p> <p>(ix) Request GSCDL to report in writing that the camp has been vacated and restored to pre-project conditions before acceptance of work.</p>		been vacated and restored to pre-project conditions
Social and Cultural Resources –	Disturbance/inc onvenience/ damage due to construction	<p>(i) Consult the city authorities to identify any buildings at risk from vibration damage and avoiding any use of pneumatic drills or heavy vehicles in the vicinity;</p> <p>(ii) Complete work in these areas quickly;</p> <p>(iii) Consult municipal authorities, custodians of important buildings, cultural and tourism authorities and local communities in advance of the work to identify and address key issues, and avoid</p>	Construction Contractor	<p>(i) Work Schedule</p> <p>(ii) Complaints from sensitive receptors</p>

Field	Anticipated Impact	Mitigation Measures	Responsible for Mitigation	Monitoring of Mitigation
		working at sensitive times, such as religious and cultural festivals.		