



REQUEST FOR PROPOSAL

For

CONSTRUCTION / UPGRADATION OF ROADS NETWORKS (PHASE 1 & 2), LAYING OF CIVIC INFRASTRUCTURE, UNDERGROUND CABLING OF HT/LT TRANSFORMERS, STREET LIGHTING, LANDSCAPING WORKS ETC. IN ABD FARIDABAD SMART CITY WITH DEFECT LIABILITY PERIOD OF TWO YEARS AND OPERATION & MAINTENANCE OF 5 YEARS.

IN FARIDABAD CITY

Under

SMART CITY MISSION (SCM)

in

FARIDABAD CITY

(HARYANA, INDIA)

Ref No: FSCL/2018/466

Issued on 19/09/2018

DNIT Amount: Rs. 231.316 Crores.

Employer: Faridabad Smart City Limited
Nain Sadan, 3rd Floor, Plot No. 35
Sector 20A, Behind EF3 Mall
Near Old Faridabad Metro Station
Faridabad - 121001
(Haryana)
Email : faridabadsmartcitylimited@gmail.com

DISCLAIMER

The information contained in this Request for Proposal document (“RFP”) or subsequently provided to bidders, verbally or in documentary or any other form by or on behalf of the Faridabad Smart City Limited (here forth referred to as FSCL in this document) or any of its employees or advisers, is provided to bidders on the terms and conditions set out in this RFP and such other terms and conditions subject to which such information is provided.

This RFP is not an agreement and is not an invitation by the Employer to the prospective Consultants or any other person. The purpose of this RFP is to provide interested bidders with information that may be useful to them in the formulation of their Proposals pursuant to this RFP. This RFP includes statements, which reflect various assumptions and assessments arrived at by the Employer in relation to the Consultancy. Such assumptions, assessments and statements do not purport to contain all the information that each bidder may require. This RFP may not be appropriate for all persons, and it is not possible for the Employer, its employees or advisers to consider the objectives, technical expertise and particular needs of each party who reads or uses this RFP. The assumptions, assessments, statements and information contained in this RFP, may not be complete, accurate, adequate or correct. Each bidder should, therefore, conduct its own investigations and analysis and should check the accuracy, adequacy, correctness, reliability and completeness of the assumptions, assessments and information contained in this RFP and obtain independent advice from appropriate sources.

Information provided in this RFP to the bidder (consultant/contractor/developer/Manufacturer/Supplier etc) is on a wide range of matters, some of which depends upon interpretation of law. The information given is not an exhaustive account of statutory requirements and should not be regarded as a complete or authoritative statement of law. The Employer accepts no responsibility for the accuracy or otherwise for any interpretation or opinion on the law expressed herein.

The FSCL and its employees and advisers make no representation or warranty and shall have no liability to any person including any bidder under any law, statute, rules or regulations or tort, principles of restitution or unjust enrichment or otherwise for any loss, damages, cost or expense which may arise from or be incurred or suffered on account of anything contained in this RFP or otherwise, including the accuracy, adequacy, correctness, reliability or completeness of the RFP and any assessment, assumption, statement or information contained therein or deemed to form part of this RFP or arising in any way in this Selection Process.

The FSCL also accepts no liability of any nature whether resulting from negligence or otherwise however caused arising from reliance of any bidder upon the statements contained in this RFP.

The FSCL may in its absolute discretion, but without being under any obligation to do so, update, amend or supplement the information, assessment or assumption contained in this RFP.

The issue of this RFP does not imply that the Employer is bound to select a bidder or to appoint the selected bidder, as the case may be, for the Consultancy and the FSCL reserves the right to reject all or any of the Proposals without assigning any reasons whatsoever.

The bidder shall bear all its costs associated with or relating to the preparation and submission of its Proposal including but not limited to preparation, copying, postage, delivery fees, expenses associated with any demonstrations or presentations which may be required by the FSCL or any other costs incurred in connection with or relating to its Proposal. All such costs and expenses will remain with the bidder and the FSCL shall not be liable in any manner whatsoever for the same or for any other costs or other expenses incurred by a bidder in preparation or submission of the Proposal, regardless of the conduct or outcome of the Selection Process.

Sd/
Chief Executive Officer
Faridabad Smart City Limited

TENDER DOCUMENT FOR THE WORK OF

Name of the Work: Construction / Upgradation of Roads Networks (Phase 1 & 2), Laying of Civic Infrastructure, Underground Cabling of HT/LT Transformers, Street Lighting, Landscaping Works etc. in ABD Faridabad Smart City with Defect Liability Period of Two Years and Operation & Maintenance of 5 Years.

INSTRUCTIONS TO BIDDERS AND QUALIFICATION INFORMATION

“FORM-B”

NIT No: Dated 19.09.2018

OFFICE OF THE FARIDABAD SMART CITY LIMITED

No.FSCL/2018/466

DATED: 19/09/2018

E-TENDER NOTICE

Faridabad Smart City Limited (FSCL) invites online tenders for the work mentioned below:-

Sr. No	T No	Name of Work	Estimated Cost of Works	EMD to be deposited by bidder (INR)	Tender Document Fee Plus Service Fee in INR	Bid Release time and Date	Last date for online Submission of bids	Tender Open Date
1	99324	Construction / Upgradation of Roads Networks (Phase 1 & 2), Laying of Civic Infrastructure, Underground Cabling of HT/ LT Transformers, Street Lighting, Landscaping Works etc. in ABD Faridabad Smart City with Defect Liability Period of Two Years and Operation & Maintenance of 5 Years.	231.316 Crores	462.632 Lakhs	1000+1000	19/09//2018 @17:30 hrs	17/10/2018 @17:30 hrs	23/10/2018 @11:00Hrs

1. Tender will be opened on 23/10/2018 @11:00 Hrs
2. The detail tender notice and Tender Document can be seen on website: <https://haryanaeprocurement.gov.in> and downloaded online from the Portal: <https://haryanaeprocurement.gov.in> by the Firms / Individual registered on the Portal.
3. Possession of Digital Signature Certificate (DSC) and registration of the contractors on the portal i.e. <http://haryanaeprocurement.gov.in> is a prerequisite for e-tendering.
4. For any other queries, please contact Deputy General Manager, Faridabad Smart City Limited, Faridabad phone no. 91-129-2410086. For further details and e-tendering schedule, visit website <https://haryanaeprocurement.gov.in/>
5. As the Bids are to be submitted online and are required to be encrypted and digitally signed, the Bidders are advised to obtain Digital Signature Certificate (DSC) at the earliest. For obtaining Digital Certificate, the Bidders should follow Section 1. Letter of Invitation-“General Terms and Conditions for e tendering ”.

Deputy General Manager
Faridabad Smart City Limited
Faridabad

**Chief Executive Officer
Faridabad Smart City Limited
Faridabad [HR]**

Name of the work	Construction / Upgradation of Roads Networks (Phase 1 & 2), Laying of Civic Infrastructure, Underground Cabling of HT/LT Transformers, Street Lighting, Landscaping Works etc. in ABD Faridabad Smart City with Defect Liability Period of Two Years and Operation & Maintenance of 5 Years.
Probable Amt. of Contract	Rs. 231.316 Crores
Amount of earnest money	Rs. 462.632 Lakhs (EMD to be submitted 50% Online payment using Net Banking/RTGS/NEFT/ and 50% in the form of Bank Guarantee. The Online receipt and Original Bank Guarantee shall be submitted along with the Technical Proposal (Envelope A) as per the time and location specified in the Data Sheet.
Application Processing Fee (Payable to FSCL)	1,000 + 1000 (Non Refundable). Document can be downloaded from the web site https://haryanaeprocurement.gov.in
Time allowed for completion of work	24 (Twenty Four) Months including rainy season.
Date of Tender Release (Online)	From 5:30 PM on 19.09.2018,
Last Date of ONLINE Bid	Up to 05:30 PM on 17.10.2018
Last date of Physical Document	UP TO 4:00 PM ON Date: 22.10.2018
Date of opening of Envelope 'A' & 'B' of tender document	Date:23.10.2018 @ 11.00 AM onwards at Office of The Chief Executive Officer, Faridabad Smart City Limited.
Online Financial Bid (Envelope C) opening.	To be intimated later.
Type of Bidder	The bidder / all partner of Consortium must be eligible bidders as per eligibility criteria laid down in RFP.
Type of Tender	Open
Vender Class	Other
Type of contract	Unit Rate Contract
Engineer-in charge	Any Officer Not below the rank of Deputy General Manager Appointed by CEO, Faridabad Smart City Limited.
Bid Validity Period	180 days

CONTENTS

Section No.	Description	Page No.
1	Invitation for Tenders (IFT)	8
2	Instructions to Bidders/Tenderers (ITB/ITT)	20
3	Qualification Information	29
4	Financial Offer : FORM 'B'	30
5	General Conditions of Contract	135
6	Special Conditions of Contract	162
7	Designs and Specifications	167
8	Annexures Part A: Annexures A to O Part B: Annexures 1 to 9	618
9	Pre Contract Integrity Pact	663

SECTION 1: INVITATION FOR TENDERS [IFT]

Faridabad Smart City Limited (FSCL) invites **Unit Rate tenders in “Form B”** from eligible bidders. **The bidder / all partner of Consortium must meet the eligibility criteria laid down in RFP and the bidder/any one firm in case of Consortium must have valid license for carrying out 11KV or above works from the Chief Electrical Inspector (CEI) of any state in India. However, before starting work, he shall seek CEI Haryana license also** and eligible under the Pre-qualification Criteria as detailed in the tender Document. The tender documents can be downloaded from <https://haryanaeprocurement.gov.in> from 19.09.2018, 5.30PM onwards. The last date of tender online submission is on 17.10.2018 up to 5: 30 PM.

A. Work Details:

Sr. No.	Name of Construction Work	Completion period	Amount of EMD	Cost of tender document (Transaction Fee)
1.	Construction / Upgradation of Roads Networks (Phase 1 & 2), Laying of Civic Infrastructure, Underground Cabling of HT/LT Transformers, Street Lighting, Landscaping Works etc. in ABD Faridabad Smart City with Defect Liability Period of Two Years and Operation & Maintenance of 5 Years.	24 (Twenty Four) Months including rainy season	Rs. 462.632 Lakhs	Rs. 1,000/- + Rs. 1000/- as online bid submission fee

B. Key Dates:

S. No.	Stages	Start Date and Time
1	Online Tender Release	19.09.2018 @5:30 PM
2	Pre Bid Meeting at FSCL Office	27.09.2018 @ 12:00 PM
3	Last Date of Receipt of Queries	28.09.2018 @ 5.30 PM
4	Last Date of Online Bid Submission	17.10.2018 @5:30 PM
5	Last Date of Physical document submission at FSCL office	22.10.2018 @4:00 PM
6	Date & time of Opening of Envelope A & B at FSCL office	23.10.2018 @11:00 AM
7	Online financial bid opening	To be intimated later

- The proposal is available online on <https://haryanaeprocurement.gov.in> from **19/09/2018 (17:30 hrs onward) to 17/10/2018 (up to 17:30 hrs)** for a non-refundable fee as indicated in the Data Sheet as scheduled in General Terms and Condition for E-tendering. Bidders will be required to register on the website, which is free of cost. The bidders would be responsible for ensuring that any addenda available on the website is also downloaded and incorporated.
- For submission of the bid, the bidder is required to have Digital Signature Certificate (DSC). Possession of Digital Signature Certificate (DSC) and registration of the contractors on the portal i.e. <https://haryanaeprocurement.gov.in> is a prerequisite for e-tendering.
- Proposal must be submitted online on <https://haryanaeprocurement.gov.in> on or before **17.30 hours on 17/10/2018** and the “Technical proposal” will be **opened online on the 23/10/2018 at 11:00 AM**. The “Financial proposal” shall remain unopened in the e-procurement system until the second public Bid opening for the financial proposal. Any proposal or modifications to proposal received outside e-procurement system will not be considered. If the office happens to be closed on the date of opening of the Proposal as specified, the Proposal will be opened on the next working day at the same time. The electronic bidding system would not allow any late submission of Proposal.
- The bidder shall also submit the Technical proposal in hard bound.
- For any other queries, please contact Deputy General Manager, Faridabad Smart City Limited, Faridabad on phone No.0129 2410086
- For further details and e-tendering schedule, visit website <https://haryanaeprocurement.gov.in>.

Yours sincerely,
 Address: Faridabad Smart City Limited,
 Nain Sadan, 3rd Floor, Plot No. 35
 Sector 20A, Behind EF3 Mall
 Near Old Faridabad Metro Station
 Faridabad - 121001(Haryana)
 Ph No. 0129 2410086
Email: faridabadsmartcitylimited@gmail.com

Eligibility Criteria:

- 1 This Invitation for Bids is open to all eligible bidders.**
- 2 All bidders shall provide a statement that the Bidder is neither associated, nor has been associated, directly or indirectly, with the Consultant or any other entity that has prepared the design, specifications, and other documents for the Project or being proposed as Project Manager for the Contract. A firm that has been engaged by the Employer to provide consulting services for the preparation or supervision of the works, and any of its affiliates, shall not be eligible to bid.**

I General Instructions to the Bidder

1. No Bidder shall submit more than one Bid for the Project. A Bidder bidding individually or as a member of a Consortium shall not be entitled to submit another BID either individually or as a member of any Consortium, as the case may be.
2. A Bidder bidding individually or as a member of a Consortium shall ensure that Power of Attorney is legalized / apostille by appropriate authority notarized in the jurisdiction where the Power of Attorney is being issued and requirement of Indian Stamp Act is duly fulfilled.
3. The Bidder should submit a Power of Attorney as per the format provided in Annexure - I, authorizing the signatory of the Bid to commit the Bidder.
4. In case the Bidder is a Consortium, the Members thereof should furnish a Power of Attorney in favor of any Member, which Member shall thereafter be identified as the Lead Member, in the format at Annexure - K. In case the Bidder is a Consortium, the Bidder shall submit Joint Bidding Agreement in the format at Annexure - J.
5. The Bid should include a brief description of the roles and responsibilities of individual members, particularly with reference to financial, technical and O&M obligations;
6. Unless otherwise indicated, the bidder means single entity or the consortium formed by the firms.

II Guidelines for participation of Consortium :

- (a) Where consortium bids are allowed, leader and members of consortium should themselves meet the experience criteria covering the respective activities of work to be performed by them on their own and not through any other arrangement like through Supporting Company, Parent / Subsidiary / Sister Subsidiary / Co-Subsidiary / Technical Collaboration / Sub-contracting. Necessary documentary evidence to this effect should be submitted with techno-commercial bid.
- (b) The members of consortium shall decide the Leader of consortium. The leader of consortium shall have minimum 26% stake in terms of bid value, as reflected in the MOU executed by consortium members. Each member of consortium shall remain jointly and severally liable to FSCL.
- (c) For this purpose the role and scope of work to be performed by the respective consortium members expressed as a percentage of bid value should be indicated in the Memorandum of Understanding (MOU) submitted along with techno-commercial bid as per format provided in the tender.
- (d) The leader of the consortium should confirm unconditional acceptance of primary responsibility of executing the 'Scope of work' of this tender. This confirmation should be submitted along with the techno-commercial bid.
- (e) The Leader of the Consortium can submit the bid on behalf of the Consortium. Memorandum of Understanding (MoU) (as per format enclosed in tender) between the Consortium members duly signed by the authority (ies) as per the note in the MOU format, must accompany the techno-commercial bid.
- (f) The MoU should clearly define the role / scope of work to be performed by each constituent and should clearly define the leader of the Consortium. All the members of the Consortium must resolve and affirm in the MoU that each party shall be jointly and severally liable to FSCL for any and all obligations and responsibility arising out of the Contract and for discharging all obligations under the Contract. MoU signed between the members of the Consortium shall form part of the contract. In case of award of contract, the MoU shall be kept valid through the entire contract period, including extensions, if any. After award of contract, no alterations / modifications would be permitted in the MoU.

- (g) Only that consortium member who has undertaken a particular activity in execution of a contract shall be considered as having technical experience of that particular activity.
- (h) In view of the complexity of nature of work involved as covered by the Bidding Documents, it is anticipated that some of the intending bidders may pool their resources and experiences to form Consortium. In their own interest, the bidders are advised to investigate the capabilities, availability of expertise and resources such as construction equipment, experienced personnel, financial soundness, past experience and concurrent engagements of constituting partners/members of the consortium.
- (i) In the event that the successful bidders is a consortium formed of two or more companies, the Company requires that the parties to the consortium accept joint and several liability for discharging all obligations under the Contract.
- (j) The tender document can be purchased in the name of Lead member of the consortium.
- (k) The bid shall be signed by all the constituents of the Consortium. Alternatively, the Leader of the Consortium may sign the bid provided a Power of Attorney from each member authorizing the Leader for signing and submission of bid on behalf of individual member must accompany the techno-commercial bid. Other members of the Consortium may participate in techno-contractual discussions and also sign the minutes of such discussions / meetings along with the Leader of the Consortium.
- (l) Leader of the Consortium on behalf of the Consortium shall co-ordinate with FSCL during the period the bid is under evaluation and also during the execution of the contract, if the same is awarded. FSCL shall correspond / communicate only with the leader of a Consortium and like-wise, the leader of the Consortium only should communicate with FSCL on behalf of the Consortium. No cognizance shall be given to communication received directly from other consortium members. The Leader of the Consortium shall also be responsible for resolving dispute / misunderstanding / undefined activities, if any, amongst all the constituents of the Consortium.
- (m) Any correspondence exchanged between FSCL and the Leader of Consortium shall be binding on all the constituents of the Consortium. The Leader of the Consortium should confirm unconditional acceptance of primary responsibility of executing the 'Scope of Work' of the tender. This confirmation should be submitted along with the techno-commercial bid.
- (n) Contract, if awarded, shall be in the name of the Consortium clearly specifying the names of all the constituents and also mentioning that the Consortium is led by which constituent. Accordingly, EMD/Bid Bond and SD/PBG shall be submitted in the name of the Consortium clearly specifying the names of all the constituents along with that of the leader.
- (o) In the event of award of contract to the Consortium, the contract shall be signed by each constituent of the Consortium. Alternatively, the Leader of the Consortium may sign the contract subject to submission of a Power of Attorney (duly notarized) from each constituent authorizing the Leader of the Consortium to sign the contract on behalf of the individual member of the Consortium. Irrespective of whether the Contract is signed by all the constituents of the Consortium or by the Leader of the Consortium, all the constituents of the Consortium shall be jointly and severally responsible for satisfactory execution of the contract.
- (p) Payment for work done under the contract shall be made by FSCL only to the Leader of the Consortium. However, in case payment is to be made directly to each constituent corresponding to their part of the scope of work, the same shall be clearly indicated in the bid along with the constituent-wise details of the price break-up.
- (q) No alteration or modification in the constituents or composition of a Consortium shall be permitted after submission of bid and also after award of the Contract during currency of the contract. A constituent of the Consortium shall be allowed to undertake and carry out only that activity for which that constituent has been evaluated and qualified technically.
- (r) Before forming a Consortium, the individual constituents of the Consortium are advised to investigate the capabilities, availability of expertise and resources such as construction equipment, experienced personnel, financial soundness, past experience and concurrent engagements of the companies with whom they propose to form a Consortium.
- (s) A constituent of the Consortium shall not be permitted to participate either in an individual capacity as a bidder or as a member of another Consortium in the same tender.
- (t) Documents/details pertaining to qualification of bidder as per proforma of document attached with the bidding documents must be furnished by each partner/member of consortium complete in all

respects along with the bid clearly bringing up their experience especially in the form of work in their scope.

- (u) In case of award to the consortium, only the leader of the Consortium shall submit the PBG for the entire requisite amount of the PBG on behalf of the Consortium.

III Pre-qualification Criteria:

- (a) All Contractors/ Bidders shall provide the requisite information accurately and with sufficient details as required in **Section-3: Qualification information**. The bid is open to all Bidders who fulfill the criteria laid down in the NIT.
- (b) **Consortium of Bidders is permitted but should be limited to maximum 3 numbers**. The Main Objective of the Consortium is to allow firms to technically collaborate for executing the various types of works defined in this tender.
- (c) **One of the CONSORTIUM firm shall have a valid license for carrying out 11 kV or above voltage works from the Chief Electrical Inspector (CEI) of any state in India. However, before starting the work, he shall seek CEI Haryana license also.**
- (d) **One of the members of CONSORTIUM shall be nominated as Lead member.**
- (e) To become eligible, bidder must satisfy the following: Criteria : The financial criteria and the value for similar works are based on the total estimated cost of work **Rs. 231.316 Crores**.
- (i) Achieved during the last Three (3) financial years (2017-18, 2016-17, 2015-16), an average annual financial turnover of at least Rs. **185.05 Crores**. In case of CONSORTIUM only the **financial reports/information of the lead member will be considered for evaluation. The Consortium Firm's financial information will NOT be considered for evaluation.**
- (ii) Satisfactorily completed similar works during last 5 years as per criteria mentioned below:
- a.** Satisfactorily completed at least one similar work of value not less than Rs. 185.05 Crores as on date of submission of financial offer, **OR**
- b.** Satisfactorily completed at least two similar works each of a value not less than Rs. 115.66 Crores as on date of submission of financial offer, **OR**
- c.** Satisfactorily completed at least three similar works each of a value not less than Rs. 92.52 Crores as on date of submission of financial offer.
- i. **Similar works means** experience in all of the below listed works in the **Category A, B and C**.

Category	Similar Works	One Similar Work	Two Similar Work	Three Similar Work
A	Construction of Urban Roads or the Highways.	51.50 Crores	32.19 Crores	25.75 Crores
B	i) Construction of underground concrete utility ducts or Supplying and Laying of R.C.C. Pipe NP3 or NP4 upto 900 mm dia with Chambers/ Manholes for Storm water system Or ii) Supplying and laying of D.I. Pipe of dia. Minimum 150 mm for Water supply including with Chambers/ Manholes Or iii) Supplying and laying of HDPE and R.C.C. NP3 Pipe of minimum dia of 300 mm for sewerage with inspection chambers/ manholes	54.28 Crores	33.93 Crores	27.14 Crores

Category	Similar Works	One Similar Work	Two Similar Work	Three Similar Work
C	Supply, Installation, Testing and Commissioning of 11KV or above, underground HT cabling, 11 KV sub station with Ring Main Unit (RMU), Ring facility of 11 kV Network	79.27 Crores	49.54 Crores	39.63 Crores
	Total	185.05 Crores	115.66 Crores	92.52 Crores

Combination of similar works indicated under the category A, B and C are permissible. However, the bidder must match the value and number of works (projects) indicated against each category in the above table. The total value of all such works will be based on the sum of the value of all the similar works considered under each category. In case of Consortium Firm, the Lead member must have experience atleast in in one of the category of similar works mentioned above.

One combination for example may be the bidder can submit one project from category A of value of Rs. 51.50 Crores, two projects of value of Rs. 33.93 Crores each from category B and three projects of value Rs. 39.63 Crores each from category C". Such similar combinations are permissible.

Necessary supporting documents duly signed under seal, by a Chartered Accountant/ or officer not below rank of Executive Engineer in original shall be enclosed while submitting the bid.

a. Note:

- i. The turnover shall be indexed at the compounded rate of 10 % (Ten percent) for each earlier year.
- ii. The value of completed work shall be updated to the value of current financial year @ compounded rate of 10 % (Ten percent).
- iii. Proof of having successfully completed similar works must be submitted in the form of a completion certificate issued by an officer not below the rank of an executive engineer. This certificate must be in the format appearing in Annexure 4. The completion certificate should clearly indicate the amount of above similar work as a part of completed projects
- iv. The indexing factors for updating the value of works completed in previous years to the current financial year are mentioned as below:

Financial Year	Indexing Factor
FY 2017-2018	1.0
FY 2016-2017	1.1
FY 2015-2016	1.21
FY 2014-2015	1.33
FY 2013-2014	1.46
FY 2012-2013	1.61

In addition to the pre-qualification criteria mentioned above the following criteria shall also be satisfied for eligibility of the Bidder:

1. The bidder / Lead member in case of Consortium should have a bank solvency of **Rs. 46.2632 Crores** issued by any scheduled Bank. The solvency certificate should not be more than twelve months old. The solvency certificate shall be on Banks Letter Head and duly signed by the Banks Designated Authority in Original. The solvency Certificate shall be as per the prescribed format provided in the Annexure 2
2. It is necessary that the bidder should have executed the above work as either main Bidder or

CONSORTIUM partner firm.

3. The bidder should not have incurred any loss in more than three years during the last five consecutive financial years. **A certificate to this effect from a Chartered Accountant shall be provided with Technical bid.**
4. The bidder should not have applied or are now part of Corporate Debt Restructuring (CDR). The bidder / Lead member in case of consortium shall submit the affidavit on their letter head.
5. Bidders should submit all requisite and necessary details/documents with respect to the eligibility criteria. The said details to be submitted in prescribed forms appended with this tender document. The details of the requisite forms are as under:
 - (i) Qualification Information (For all firms) Annexure- 1
 - (ii) Banker's Certificate (Solvency Certificate of the Lead Member only) Annexure-2
 - (iii) Details of Similar Works executed (For all firms) Annexure-3
 - (iv) Details of All works executed during last 5 (Five) years (For all firms) Annexure-4
 - (v) Existing commitments and on-going works (For all firms) Annexure-5
 - (vi) Information regarding current claims, arbitration & litigation, if any(For all firms)Annexure-6
 - (vii) Affidavit of having provided all correct information (For all firms) Annexure-7
 - (viii) List of Plant & Equipment to be deployed Annexure- 8
 - (ix) List of Technical person to be deployed Annexure-9

Note: All aforesaid Annexure must bear the seal and signature of the Bidder or a duly authorized person.

1. Bidder must ensure providing complete information in Annexures mentioned above along with their signatures [under seal] wherever required, before submission of tender.
2. Each Bidder must enclose
 - a) Certified Copies of Income Tax Returns for the last 5 (Five) years duly audited by Chartered Accountant including his audit report. CA shall certify the true copy in original.
 - b) Turnover certificate of Last 5 Years certified by Chartered Accountant in Original.
 - c) An affidavit that all the information furnished with the pre-qualification document is correct in all respects (Draft format of Affidavit is provided in the tender document).
3. The Lead Member who meets the minimum qualification criteria will be qualified only if their available bid capacity for construction work is equal to or more than the probable amount of estimated cost. The available bid capacity will be calculated as under:

$$\text{Assessed Available Bid capacity} = (A * N * M - B)$$

Where,

A = Maximum value of all works executed in “ any one financial year” during the last Five years [updated to the price level at the current financial year at the compounded rate of 10% (Ten per cent) a year taking into account the completed as well as work in progress]. This has to be certified by a Chartered Accountant.

N = Number of years prescribed for completion of the works for which tender is invited (period up to 6 months to be taken as half-year and more than 6 months as one year). Any period beyond 12 months, the period actually mentioned in the NIT shall be considered.

M = 2.5

B = Value of existing commitments and on-going works to be completed during the period of completion of the work for which tender is invited.

4. The Bidder should have valid GST. Copies of latest GST returns filed with Sales Tax Dept. along with a certificate of the Bidder that these returns have been filed with the Sales Tax Dept.
5. The bidder should have valid ESIC registration Certificate. A self certified copy must be submitted.
6. The bidder should be registered with the Commissioner, Provident Fund if he has 10 or more than 10 persons in his employment and should submit copy of the registration along with the Technical bid.. If registration is applicable and bidder is not registered then bidder will submit affidavit to get registered with the Commissioner , Provident Fund before signing the agreement. If the bidder fails to submit the PF registration certificate before signing the agreement, FSCL reserve the right to cancel the bid. In case the bidder has less than 10 persons in his employment, he shall submit an affidavit to this effect in lieu of such registration.
7. Submit the Pre Integrity Pact on Rs. 100 Stamp paper as indicated in Section 9.
8. Submit an undertaking that the bidder will be able to invest minimum up to 25% of contract value of work, during implementation of work.
9. Even though the Bidder meets the above qualifying criteria, he is subject to be disqualified if he has;
 - a) Made a misleading or false representation[s] in the Forms, Statements and Attachments submitted in Proof of the Qualification Requirements.And/ Or
 - b) A record of poor performance such as Abandoning a work, Poor quality of work, Claim, Litigation History, or Financial failures etc. in any State Govt. organization/services/corporations/local body etc. (by whatever names these are called).

Chief Executive Officer
Faridabad Smart City
Limited
Faridabad HR

General Terms and Conditions for E-tendering:

1. The detail tender notice and Tender Document can be seen on website: <https://haryanaeprocurement.gov.in> and downloaded online from the Portal: <https://haryanaeprocurement.gov.in> by the Firms / Individual registered on the Portal.
2. As the proposals are to be submitted online and are required to be encrypted and digitally signed, the Bidders are advised to obtain Digital Signature Certificate (DSC) at the earliest.
3. The payment for Tender Document Fee and e-service Fee shall be made by eligible bidders online directly through Debit Cards & Internet Banking Accounts and the payment for EMD can be made online directly through RTGS/NEFT or OTC Please refer to „Online Payment Guideline“ available at the Single e-Procurement portal of GoH (Govt. of Haryana) and also mentioned under the Tender Document.
4. Intending bidders will be mandatorily required to online sign-up (create user account) on the website <https://haryanaeprocurement.gov.in> to be eligible to participate in the e-Tender. He/ She will be required to make online payment towards EMD fee in due course of time i.e. **between 19/09/2018 (from 18:00 Hours) to 16/10/2018 (up to 16:00 Hours)**. The intended bidder fails to pay EMD fee under the stipulated time frame shall not be allow to submit his / her Proposal for the respective event / tenders.
5. The interested bidders must remit the funds at least T+1 working day (Transaction + One working Day) in advance i.e. on or before 16/10/2018 (up to 16:00 Hours); and make payment via RTGS /NEFT or OTC to the beneficiary account number specified under the online generated challan. The intended bidder / Agency thereafter will be able to successfully verify their payment online, and submit their Proposal on or before the expiry date & time of the respective events/Tenders at <https://haryanaeprocurement.gov.in>.
6. The undersigned reserves the right to reject any or all the tenders without assigning any reason what so ever and no conditional and postal tenders will be accepted.
7. If the date on which the tenders are to be received is declared a public holiday, the tender will be received on the next working day.
8. The offer will remain valid up to 180 days from the due date of submission of tenders.
9. Any amendment to a tender after opening of tender made by the tenderer according to his own will is liable to be ignored altogether and such tenderer will be debarred from tendering for a period of six months

Check List for online submission of Documents

Envelop A (Mandatory documents) :

1. Letter of EMD
2. Online deposit receipt of EMD and Scan copy of Bank Guarantee
3. Scanned Copy of Pre Contract Integrity Pact duly Signed (On Rs. 100 Non judicial stamp Paper, duly Notarized)

Envelop B:

4. Letter of Technical Bid
5. Power of Attorney on Rs. 100 Stamp Paper authorizing for signing the bid documents
6. Qualification Information (Annexure 1)
7. Copy of ESIC Certificate
8. Copies of latest GST.
9. Copy of registration with Commissioner PF.
10. Affidavit of having provided all correct information (Annexure-7)
11. Information regarding current claims, arbitration & litigation, if any (Annexure-6)
12. Existing commitments and on-going works (Annexure-5)
13. Details of all works executed during last 5 (Five) years (Annexure-4)
14. Details of similar works executed (Annexure-3)
15. Income Tax returns for last 5(Five) Years
16. Bankers Certificate in original on Banks Letter head (Solvency Certificate) (Annexure-2)
17. List of Plant & Equipment to be deployed (Annexure -8)
18. List of Technical person to be deployed (Annexure -9)
19. Affidavit of not have applied or are now part of CDR.
20. Duly signed RFP including all corrigendum's and Pre bid responses (if any)

Section 1a:

Letter of EMD – Envelop – ‘A’

To,

**Chief Executive Officer,
Faridabad Smart City Limited
Nain Sadan, 3rd Floor, Plot No. 35
Sector 20A, Behind EF3 Mall
Near Old Faridabad Metro Station
Faridabad – 121001
(Haryana).**

Sub: Construction / Upgradation of Roads Networks (Phase 1 & 2), Laying of Civic Infrastructure, Underground Cabling of HT/LT Transformers, Street Lighting, Landscaping Works etc. in ABD Faridabad Smart City with Defect Liability Period of Two Years and Operation & Maintenance of 5 Years.

.

Dear Sir,

Enclosed please find online deposite receipt favour of **Faridabad Smart City Limited** against Earnest Money Deposit for the work mentioned.

Thanking You

Yours Faithfully

For and on behalf

(Seal and Signature of the Authorized Signatory)

Enclosure:

Letter of Technical Bid Envelop –‘B’

To,

**Chief Executive Officer,
Faridabad Smart City Limited
Nain Sadan, 3rd Floor, Plot No. 35
Sector 20A, Behind EF3 Mall
Near Old Faridabad Metro Station
Faridabad – 121001
(Haryana).**

For Bid Invitation No.:

Date:

We, the undersigned, declare that:

- (a) We have examined and have no reservations to the Bidding Documents, including Addenda issued in accordance with Instruction to Bidders (ITB);
- (b) We offer to execute in conformity with the bidding Documents the following Work/s: **Construction / Upgradation of Roads Networks (Phase 1 & 2), Laying of Civic Infrastructure, Underground Cabling of HT/LT Transformers, Street Lighting, Landscaping Works etc. in ABD Faridabad Smart City with Defect Liability Period of Two Years and Operation & Maintenance of 5 Years.**
- (c) Our bid shall be valid for a period of **180 days** from the bid submission due date in accordance with the bidding documents, and it shall remain binding up on us and may be accepted at any time before the expiration of that period;
- (d) **If our bid is accepted, we commit to obtain a performance security in accordance with the Bidding Documents;**
- (e) We, including any sub-Bidders or suppliers for any part of the contract, do not have any conflict of interest in accordance with ITT;
- (f) We are not participating, as a Bidder in more than one bid in this bidding process in accordance with the ITT,
- (g) Our firm, its affiliates or subsidiaries including any Sub-Bidders or suppliers for any part of the contract, has not been declared ineligible by Government of Haryana (GoH)/ Government of India (GoI) or any of its undertakings/Other Departments any State Government, any public sector unit or any Local Body.
- (h) We understand that this bid, together with your written acceptance thereof included in your notification of award, shall constitute a binding contract between us, until a formal Contract is prepared and executed.
- (i) We understand that you are not bound to accept the lowest evaluated bid or any other bid that you may receive.
- (j) We are not a Government owned entity / we are a Government owned entity, meeting all the requirements of the ITT.

Seal and Signature:

Name.....

Signed in the capacity of.....

Duly authorized to sign the Bid for and on behalf of..... Date:
.....

SECTION 2: INSTRUCTIONS TO BIDDERS/TENDERERS (ITB/ITT)

Table of Clauses

A. Introduction

B. General

1. Scope of Tender
2. Eligible Bidders
3. Qualification of the Bidder
4. One Tender per Bidder
5. Cost of Tendering
6. Site Visit

C. Tender Documents

7. Content of Tender documents
8. Clarification of Tender Document
9. Amendment of Tender documents

D. Preparation of Tenders

10. Documents Comprising the Tender
11. Tender Prices
12. Tender Validity
13. Earnest Money Deposit
14. Format and Signing of Tender

E. Submission of Tenders

15. Procurement of Tender
16. Deadline for Submission of Tenders
17. Late Tenders

F. Tender Opening and Evaluation

18. Opening of Envelope A & B of All Bidders and Evaluation to Determine Qualified Bidders
19. Qualified Bidders and Evaluation
20. Process to be Confidential
21. Clarification of Tenders
22. Examination of Tenders and Determination of Responsiveness
23. Correction of Errors
24. Evaluation and Comparison of Tenders

G. Award of Contract

25. Award Criteria
26. Employer's Right to accept any Tender and to reject any or all Tenders
27. Notification of Award and Signing of Agreement

A. Introduction:

With a view to improve urban centers of India and make them citizen friendly and sustainable, the Government of India through the Union Ministry of Urban Development (MoUD) has initiated the Smart Cities Mission. The program is oriented around urban renewal and retrofitting of 100 cities in India in collaboration with the State Governments and the respective City Authorities.

The method of selection of the cities is through competition wherein the following two stages are already complete:

Stage I: Shortlisting of cities by States,

Stage II: The Challenge round for selection

After completion of Stage II, 20 selected Smart Cities were declared in Round 1. Subsequently, 13 cities were selected in Fast Track Round, which included the City of Faridabad.

The Ministry of Urban Development, Government of India vide its memo no. K-15016/.157/2015-SC-1 (vol.II) dated 26th May, 2016 directed Government of Haryana to constitute Special Purpose Vehicle (SPV) for Faridabad Smart City Limited. The Special Purpose Vehicle will implement the smart City Proposals prepared by Municipal Corporation, Faridabad and duly approved by MoUD under the smart City Mission of Government of India. Faridabad Smart City Limited was incorporated on Twentieth day of September Two Thousand sixteen under the Companies Act, 2013 and the company is limited by shares.

The Special Purpose Vehicle is constituted for Faridabad Smart City Limited under:

B. Constitution of Board of Directors:

The Board of Directors of Faridabad Smart City Limited shall comprise of the following members

1	Principal Secretary to Govt. of Haryana, Urban Local Bodies Department	Chairman
2	Mission Director, Urban Local Bodies Department	Director
3	Chief Administrator, HUDA	Director
4	Representative of Govt of India	Director
5	Chief Executive Officer of SPV	Commissioner, Municipal Corporation, Faridabad
6	Independent Directors (3 Nos.)	Director

After selection of Faridabad in the Fast Track Round, the process of implementation has been initiated with the setting up of the SPV – Faridabad Smart City Limited (FSCL). FSCL has appointed (PMC) to Design, Develop, Manage and Implement the Smart City Project under the Smart City Mission.

In order to achieve the vision set out in the Smart City Proposal, the city has identified projects under the two categories of Area Based Development and Pan City Solutions as follows:

Area Based Development: 3 Modules, 8 Sub Modules consisting of 59 sub-projects with an estimated cost of Rs. 1916 crores.

Pan City Solution: 1 Module and 09 Sub-projects with an estimated cost of Rs. 425 crores.

FSCL is interested in taking up the construction of smart road years on priority basis. As per the Smart City Proposal, the funding for this project is being sourced from Smart City Mission of Government of India.

Although FSCL is envisaging constructing many more roads at various places within ABD, it is interested in taking up works at selected location on pilot basis. The location of the Smart Road is enclosed at the end of this document.

FSCL is now inviting eligible bidders for the works “**Construction / Upgradation of Roads Networks (Phase 1 & 2), Laying of Civic Infrastructure, Underground Cabling of HT/LT Transformers, Street Lighting, Landscaping Works etc. in ABD Faridabad Smart City with Defect Liability Period of Two Years and Operation & Maintenance of 5 Years**”.

The Defect Liability Period (DLP) shall be for a period of two years from the date of actual completion of the work. The completion of work shall be reckoned from the date of issue of completion certificate by the FSCL. The Bidder shall not claim the cost of works/items covered under the DLP.

FSCL reserves the right to add/ reduce or delete items at its discretion without providing any reasons. All the additional items shall be paid as per prevailing HSR rate. (In case the rates are not available in the HSR then rates shall be taken either from other states SOR rates or as decided by Engineer-In-Charge.

Further, the following smart features would be likely added to the proposed Smart Road

CCTV

WiFi

Smart LED Poles

E-Toilet

Vending Zone

Smart Furnitures

Information Kiosks

Digital Signage and markings

Laying OFC which will be connected to temporary data center which in turn be connected to Control and Command Centre.

All the above features will **NOT** be a part of this tender. The works will be taken up under different tender/contract.

In case, different works are to undertaken simultaneously, the bidders shall coordinate the works with other contractor who will be working simultaneously on same site.

General

1. Broad Scope of Tender

The Faridabad Smart City Limited (abbreviated as ‘FSCL’ and Referred to as the ‘Employer’ in these documents) invites Unit Rate Tenders from eligible Bidders for the Works as defined as “**Construction / Upgradation of Roads Networks (Phase 1 & 2), Laying of Civic Infrastructure, Underground Cabling of HT/LT Transformers, Street Lighting, Landscaping Works etc. in ABD Faridabad Smart City with Defect Liability Period of Two Years and Operation & Maintenance of 5 Years**” in this document and referred to as "the Works").

The detailed Scope of Works and the Drawings can be referred at Section 7 and Annexure F of this document.

2. **Eligible Bidders:** shall be as defined in Section 1.

3. **Qualification of the Bidder:** shall be as defined in Section 1.

4. One Tender per Bidder: Each Bidder shall submit only one Tender for the Project. A Bidder who submits or participates in more than one Tender (other than as a Sub Bidder or in cases of alternatives that have been permitted or requested) will cause all the Proposals with the Bidder’s Participation to be disqualified.

5. **Cost of Tendering:** The Bidder shall bear all Costs associated with the Preparation and Submission of his Tender and the Employer will in no case be Responsible and Liable for those Costs.
6. **Site Visit:** The Bidder, at his own Responsibility and Risk, is encouraged to visit and examine the Site of Works and its surroundings and obtain all Information that may be necessary for preparing the Tender and entering into a Contract for construction and execution of the Works. The cost of visiting the site shall be at the Bidder's own expense.

C. Tender Documents

7. Content of Tender Documents

The Set of Tender Documents shall have all the Sections given in 'Contents' of this document.

8. Clarification of Tender Documents

A prospective Bidder requiring any clarification of the Tender Documents may present himself with his queries in the pre-bid meeting as detailed in the N.I.T. or send the same at the address/email indicated in the bid document so that these may reach the Authority before the date and time mentioned under KEY DATES.

9. Amendment of Tender Document

9.1. Before the Deadline for Submission of Tenders, the Employer may modify the Tender Document by issuing Addenda.

9.2. Any Addendum thus issued shall be part of the Tender Documents and shall be updated on the website and **NOT** communicated in writing to any purchaser of the Tender Document. To give Prospective Bidders reasonable time in which to take an Addendum into account in preparing their Tenders, the Employer may extend, as necessary, the Deadline for **Submission of Tenders, in accordance with S. No. 16 below.**

D. Preparation of Tenders

10. Documents Comprising the Tender

Only Technical Proposal shall be submitted both physically (hard Copy) as well as online. **FINANCIAL PROPOSAL SHALL BE SUBMITTED ONLINE ONLY.** The hard Copy of the Tender shall be submitted by the Bidder with Two sealed envelope and shall contain the Documents as follows.

Envelope A:

Online **Earnest Money Deposit Receipt: Rs. 462.632 Lakhs** (50% i.e. **Rs. 231.316 Lakhs** through online payment using Debit Card/Net Banking/RTGS/NEFT and balance 50% i.e. **Rs. 231.316 Lakhs** in the form of bank guarantee in favour of Chief Executive Officer, Faridabad Smart City Limited as per the format provided . the bidder shall upload the scan copy of Bank Guarantee in the E-Procurement Portal along with Technical Bid and Original copy along with physical submission in a separate, sealed envelope).

Letter of EMD (Envelope A)

Pre Contract Integrity Pact duly signed (On Rs. 100 Non judicial stamp Paper, duly Notarized)

Envelope B:

Letter of Technical Bid (Envelop B- as per format given in Page 14.)

Pre-Qualification Information as per Formats given in Section-1: Pre-qualification document.

Any other information required for completing and submitting the tender by Bidders in accordance with these Instructions.

The Documents Listed under Sections - 1 shall be filled and submitted in without exception.

11. Tender Prices

11.1. The Contract shall be for the Whole Works as described in General Scope of Works clause 1.0 and its Sub Clause 1.1.

11.2. The Unit Rate Price shall be inclusive of all taxes including Goods and Service Tax (GST) as applicable by the law. The Unit rates quoted by the bidders shall include Goods and Service tax. The quoted rate shall therefore be including the Goods and Service tax and other taxes & Duties, such as Labour Cess, Royalties, etc. imposed by the Government (State or Central)] and other Levies payable by the Bidder under the contract or for any other cause. FSCL will not be responsible for changes in any of the tax rates.

11.3. The Lump sum Price quoted by the Bidder shall be subject to adjustment during the Performance of the Contract in Accordance with the Provisions of the General Conditions of Contract.

12. Tender Validity

12.1. Tenders shall remain valid for a period not **less than 180 days** after the Deadline Date for Tender Submission specified in Clause - 16. A Tender valid for a Shorter Period shall be rejected by the Employer as Non Responsive. In Exceptional Circumstances, prior to expiry of the Original Time Limit, the Employer may request that the Bidders may extend the Period of Validity for a specified additional period. The request and the Bidders' responses shall be made in writing. A Bidder may refuse the request without forfeiting his Earnest Money Deposit. A Bidder agreeing to the request will not be required or permitted to modify his Tender, but will be required to extend the Validity of his Earnest Money Deposit for a period of the extension, and in compliance with Clause - 13 in all respects.

13. Earnest Money Deposit

13.1. The Bidder shall make the Earnest Money **Deposit Rs. 462.632 Lakhs** (50% i.e. **Rs. 231.316 Lakhs** through online payment using Debit Card/Net Banking/RTGS/NEFT and balance 50% i.e. **Rs. 231.316 Lakhs** in the form of bank guarantee in favour of Chief Executive Officer, Faridabad Smart City Limited as per the format provided. the bidder shall upload the scan copy of Bank Guarantee in the E-Procurement Portal along with Technical Bid and Original copy along with physical submission in a separate, sealed envelope).

13.2. Any Tender not accompanied by an acceptable Earnest Money Deposit as indicated in Sub Clause 13.1 above shall be rejected by the Employer as Non Responsive.

13.3. The Earnest Money Deposit of unsuccessful Bidders shall be returned within 30 days of the end of the Tender Validity Period specified in Sub Clause 12.1

13.4. The Earnest Money Deposit of successful Bidders shall be returned after production of Performance Security and signing of Agreement

13.5. The Earnest Money Deposit made by a Bidder may be forfeited:

- (a) If the Bidder withdraws the Tender after Tender Opening or during the Period of Tender Validity;
- (b) If the Bidder does not accept the Correction of the Tender Price, pursuant to Clause 23; or
- (c) In the case of a successful Bidder, if the Bidder fails within the specified time limit to execute the Agreement with the FSCL for works under this bid.

14. Format and signing of Tender:

14.1. The tendering system for the work comprises three stages

- (i) EMD
- (ii) Technical Bid [Eligibility qualification]
- (iii) Online Financial Bid.

The Bidders are required to submit the online tender and submit hard copy with all required documents in Three Sealed Envelopes – A & B, as detailed above, manually within specified time and date at the address given below.

**Chief Executive Officer,
Faridabad Smart City Limited
Nain Sadan, 3rd Floor, Plot No. 35
Sector 20A, Behind EF3 Mall
Near Old Faridabad Metro Station
Faridabad – 121001
(Haryana).**

14.2. In Stage II [Technical Bid] the Bidder shall prepare the Documents comprising the Tender as described in Clause - 10 of these Instructions to Bidders. Bidders shall attach all Copies of Certificates pertaining to their Eligibility Criteria, Qualification Information Documents and Credit lines / Letter of Credit / Certificates from Scheduled Banks, failing which the Bid shall not be considered.

14.3. Stage III - SUBMISSION OF ONLINE FINANCIAL BID. (DO NOT SUBMIT FINANCIAL PROPOSAL PHYSICALLY).

14.4. The Tender shall contain no Alterations or Additions, except those to comply with instructions issued by the Employer.

E. Submission of Tenders

15. Procurement of Tenders

Tender Documents may be downloaded from the e procurement portal <https://haryanaeprocurement.gov.in> as indicated in the NIT

Bidders shall submit signed, complete Proposal comprising the documents and forms in accordance with Clause 10 (Documents Comprising Proposal). The submission shall be physically (hard Copy) as well as online.

Only the authorized representative of the Bidder shall sign the original submission letters in the required format for the Qualification Documents, Technical Proposal and the Financial Proposal and shall initial all pages as required. The authorization shall be in the form of a written power of attorney attached to the Qualification Documents Proposal.

Any modifications, revisions, interlineations, erasures, or overwriting shall be valid only if they are signed or initialed by the person signing the Proposal.

The signed Proposal shall be marked "Original". The scanned Copy shall be made from the signed original and submitted online. If there are discrepancies between the original and the scanned copies submitted online, the tender committee at FSCL shall decide the one prevails.

If the envelopes and packages with the Proposal are not sealed and marked as required, the Client will assume no responsibility for the misplacement, loss, or premature opening of the Proposal.

16. Deadline for Submission of the Tenders

16.1. As per KEY DATES given in tender notice.

16.2. The Employer may extend the Deadline for Submission of Tenders by issuing an Amendment in accordance with Clause - 9, in which case all Rights and Obligations of the Employer and the Bidders previously subject to the original deadline will then be subject to the new deadline.

17. Late Tenders

17.1. Envelopes 'A & B' received by the Employer after the Deadline prescribed As per **KEY DATES** given in tender notice will **not** be accepted.

F. Tender Opening and Evaluation

18. Opening of Envelope ‘A’ [EMD] and Envelope ‘B’ of all Tenders and Evaluation to determine Qualified Bidders:-

- 18.1. The Employer shall open Envelope ‘A’ of all the Tenders received (except those received late), in the presence of the Bidders or their representatives who choose to attend such opening of Envelope ‘A’ of the Tender at 11.00 HOURS **ON 23.10.2018** at the office of the Chief Executive Officer, Faridabad Smart City Limited. In the event of the Specified Date of Tender Opening being declared a holiday for the Employer, the Tenders will be opened at the appointed time and location on the next working day.
- 18.2. The Bidders’ Names, the Presence or Absence of Earnest Money Deposit (Amount, Format and Validity), will be announced by the Employer at the opening. Late Submission of EMD will be rejected, unopened (wherever Applicable).
- 18.3. Envelope ‘B’ [Qualification Information] only of those Bidders who have submitted all the documents prescribed in Envelope A and are found in order in all respects shall be opened for technical evaluation.
- 18.4. The Employer shall prepare Minutes of the Tender Opening, including the information disclosed to those present in accordance with Sub Clause - 18.3 (Wherever Applicable).
- 18.5. **Online tender of other bidders shall be kept unopened.**
- 18.6. The Employer will evaluate and determine whether each Tender (a) meets the Eligibility Criteria defined in ITT Clause - 2; (b) is accompanied by the Required Earnest Money Deposit as per stipulations in ITT Clause 10 and (c) meets the Minimum Qualification Criteria stipulated in ITT Clause – 3 (Section1). The Employer will draw out a List of Qualified Bidders and will intimate these Qualified Bidders.

19. Opening of online tender of Qualified Bidders and Evaluation.

- 19.1. The Employer will inform all the qualified Bidders the Time, Date and Venue fixed for the opening of online tender containing the Unit Rate financial offer. The Employer will open the online tender of Qualified Bidders at the Appointed Time and Date in the presence of the Bidders or their Representatives who choose to attend. In the event of the Specified Date of online Tender opening being declared a holiday for the Employer, Online Tender shall be opened at the appointed Time and Location on the next working day.
- 19.2. The Bidders names, the Tender Prices, any discounts, and such other details as the Employer may consider appropriate, will be announced by the Employer at the time of opening.
- 19.3. The Employer shall prepare Minutes of the Online Tender Opening, including the Information disclosed to those present in accordance with Sub Clause - 19.2.

20. Process to be Confidential

- 20.1. Information relating to the Examination, Clarification, Evaluation, and Comparison of Tenders and recommendations for the Award of a Contract will not be disclosed to Bidders or any other persons not officially concerned with such process until the Award to the successful Bidder has been announced. Any effort by a Bidder to influence the Employer’s processing of Tenders or award decisions may result in the rejection of his Tender.

21. Clarification of Tenders Clarification of Tenders

- 21.1. To assist in the Examination, Evaluation and Comparison of Tenders, the Employer may, at his discretion, ask any Bidder for clarification of his Tender. The request for clarification and the response shall be in writing, but no change in the price or substance of the Tender shall be sought, offered or permitted except as required to confirm the Correction of Arithmetic Errors discovered by the Employer in the evaluation of the Tenders in accordance with Clause - 24.

21.2. Subject to Sub Clause 21.1, no Bidder shall contact the Employer on any matter relating to its Tender from the time of the Tender opening to the time the Contract is awarded. If the Bidder wishes to bring additional information to the notice of the Employer, he should do so in writing.

21.3. Any effort by the Bidder to influence the Employer in the employer's Tender Evaluation, Tender Comparison or contract award decisions may result in the rejection of the Bidders' Tender.

22. Examination of Tenders and Determination of Responsiveness

22.1. Prior to the Detailed Evaluation of Tenders, the Employer will determine whether each Tender; (a) has been properly signed; and (b) is substantially responsive to the requirements of the Tender Documents.

22.2. A Substantially responsive Tender is one which

- Confirms to all the conditions or criteria set in the pre-qualification criteria
- submission of all supporting documents indicated in Section 1,
- EMD, Transaction (Document Fee), Processing Fee, Pre Contract Integrity Pact (in prescribed format) are enclosed,
- All forms and annexures are enclosed.
- Bid Capacity is achieved.
- Terms Conditions and Specifications of the Tender Documents, without material deviation or reservation. A material deviation or reservation is one (a) which affects in any substantial way the Scope, Quality or Performance of the Works; (b) which limits in any substantial way, inconsistent with the Tender Documents, the Employer's Rights or the Bidder's obligations under the Contract; or (c) whose rectification would affect unfairly the competitive position of other Bidders presenting substantially responsive Tenders.

22.3. If a Tender is not substantially responsive, it will be rejected by the Employer, and may not subsequently be made responsive by correction or withdrawal of the non-conforming deviation or reservation.

23. Correction of Errors

23.1. Tenders determined to be substantially responsive will be checked by the Employer for any arithmetic errors.

23.2. The amount stated in the Tender will be adjusted by the Employer for the correction of errors and with the concurrence of the Bidder, shall be considered as binding upon the Bidder. If the Bidder does not accept the corrected amount, the Tender will be rejected, and the earnest money deposit may be forfeited in accordance with Sub-Clause 13.4 (b).

24. Evaluation and Comparison of Tenders

24.1. The Employer will evaluate and compare only the Tenders determined to be Substantially Responsive in accordance with Clause - 22.

24.2. In evaluating the Tenders, the Employer will determine for each Tender the evaluated Tender Price by adjusting the Tender Price as follows:

(a) Making any Correction for Errors pursuant to Clause - 23.

24.3. The Employer reserves the right to accept or reject any variation, deviation or alternative offer. Variations, deviations and alternative offers and other factors, which are in excess of the requirements of the Tender documents or otherwise result in unsolicited benefits for the Employer, shall not be taken into account in Tender Evaluation.

After Evaluation of the Price Analysis, the Employer may require that the amount of the Performance Security be increased at the expense of the Successful Bidder to a level sufficient to protect the Employer against financial loss in the event of default of the successful Bidder under the contract.

G. Award of Contract

25. Award Criteria

25.1. Subject to Clause-26, the Employer will award the Contract to the Bidder whose Tender has been determined to be substantially responsive to the Tender Documents and who has offered the Lowest Evaluated Lump sum Tender Price, provided that such Bidder has been determined to be (a) Eligible in accordance with the Provisions of Clause - 2, and (b) Qualified in accordance with the Provisions of Clause - 3.

26. Employer's Right to accept any Tender and to reject any or All Tenders

26.1. Notwithstanding Clause - 25, the Employer reserves the right to accept or reject any Tender, and to cancel the Tender process and reject all Tenders, at any time prior to the Award of Contract, without thereby incurring any liability to the affected Bidder or Bidders or any obligation to inform the affected Bidder or Bidders of the grounds for the Employer's action.

27. Notification of Award and Signing of Agreement

27.1. The Bidder whose Tender has been accepted will be notified in writing of the award by the Chief Executive Officer prior to expiration of the Tender validity period. This written communication from the employer to the successful Bidder shall be termed as the "Letter of Acceptance". This Letter (hereinafter called the "Letter of Acceptance") will state the sum that the Chief Executive Officer will pay the Bidder in consideration of the execution and completion of the Works by the Bidder as prescribed by the Contract (herein after and in the Contract called the "Contract Price").

27.2. The Notification of award will constitute the formation of the Contract.

27.3. The Agreement will incorporate all Agreements between the Chief Executive Officer from FSCL and the successful Bidder. It will be kept ready for signature of the successful Bidder in the office of the Chief Executive Officer within 21 days following the notification of award along with the Letter of Acceptance. Within 7 days of Receipt, the successful Bidder will sign the Agreement and deliver it to the Chief Executive Officer, FSCL. The duration of the project will be considered from the date of issue of work order or date stipulated in the work order. The format of agreement as per Annexure -M

SECTION 3: QUALIFICATION INFORMATION

- 1.1. The Bidder shall meet the Pre-qualification Criteria indicated in Section 1.
- 1.2. The Bidder performance for each work completed in the last 3 years and those in hand should be certified by an officer not below the rank of Engineer-In-Charge or equivalent. Details should be furnished in **Annexure-4**.
- 1.3. The Bidder should furnish a legal document in the form of an Affidavit in the Performa appearing in **Annexure-7** guaranteeing the truth and accuracy of all statements and information furnished by the bidder as part of this Tender. The Affidavit shall also authorize FSCL to approach any authority/person to verify the accuracy of the information furnished or enquire about the Bidder competence and his Reputation in general.
- 1.4. Tender submitted by a Bidder, who has been debarred from undertaking any work or has been black-listed by any organization/agency in India as on the date of submission of this tender, shall be summarily rejected.
- 1.5. Bidder should have its own in-house electrical wing fulfilling all the terms & conditions given in the electrical sub heads or can associate any electrical contractor who fulfils the requisite criteria given in the electrical sub heads in the tender document.

Note: The Bidder is required to furnish all information in all the FORMS and their appurtenant formats included herein, (duly signed with seal) failing which the tender is liable to be rejected.

**FORM B - TENDER FOR UNIT RATE CONTRACT
(TO BE SUBMITTED ONLINE WITH DIGITAL SIGNATURE)**

I/we hereby tender to execute the whole of the works as described in the scope of services indicated in called works:

- a) **Name of the Work:** “Construction / Upgradation of Roads Networks (Phase 1 & 2), Laying of Civic Infrastructure, Underground Cabling of HT/LT Transformers, Street Lighting, Landscaping Works etc. in ABD Faridabad Smart City with Defect Liability Period of Two Years and Operation & Maintenance of 5 Years”
- b) **Location Plan and Specifications:** The location plan and specifications as detailed in Section 7: Designs and Specifications and appearing in Annexure F.
- c) **Scope as defined in ITT clause 1 under “General”**

S. No.	Description of the Item	Total Rate (Rs.) (in figure)	Total Rate (Rs.) (In words)
1	Construction / Upgradation of Roads Networks (Phase 1 & 2), Laying of Civic Infrastructure, Underground Cabling of HT/LT Transformers, Street Lighting, Landscaping Works etc. in ABD Faridabad Smart City with Defect Liability Period of Two Years as per the total detailed BOQ S.No.1-532 which is mentioned below. Total “A”(Value of A from table)		
2	Operation & Maintenance for 5 years as per detailed BOQ S.No. 533-552 (Total of 1 st year to 5 th Year), Total “ B ”		
3	Grand Total “C” (Inclusive of GST and other Taxes)		

Note: No escalation of Price shall be considered during the contract period.

The bids will be evaluated on the basis of amount quoted against “C “: **Grand Total (C) in INR**

(Lump sum Inclusive of all taxes including Goods and Service Tax (GST)

Total sum of (In Figures as in “C”) Rs..... (In Words) Rupees

.....
.....

And should this tender be accepted, I/we do here by agree and bind myself/ ourselves to abide by and fulfil all the conditions of this Tender Document, in default thereof to forfeit and pay to the **Chief Executive Officer, Faridabad Smart City Limited** the penalties of sums of money mentioned in the said condition.

Dated:

Bidder’s Signature

Address Seal

Witness:

Address:

The above tender is hereby accepted by me on behalf of the Faridabad Smart City Limited.

(Designation)

SIGNATURE OF AUTHORITY BY WHOM the TENDER IS ACCEPTED

BILL OF QUANTITIES

Preamble

1. The Bill of quantities shall be read in conjunction with the instructions to Bidders, Conditions of contract, Technical Specifications and Drawings. Wherever applicable, the interpretation of Items mentioned in the BOQ shall be as per HSR.
2. The quantities given in the Bill of Quantities are estimated and provisional, and are given to provide a common basis for bidding. The basis of payment will be the actual quantities of work ordered and carried out, as measured by the Contractor and verified by the Engineer and valued at the rates and process tendered in the priced Bill of Quantities, where applicable, and otherwise at such rates as the Engineer may fix within the terms of the Contract.
3. The rates and prices tendered in the Bill of Quantities shall, except in so far as it is otherwise provided under the Contract, include all constructional plant, labour, supervision, materials, erection, maintenance, insurance, profit, taxes and duties, together with all general risks, liabilities and obligations set out of implied in the Contract.
4. The rates and prices shall be quoted entirely in Indian Currency.
5. A rate or price shall be entered against each item in the Bill of Quantities, whether quantities are stated or not. The cost of Item against which the contractor has failed to enter a rate or price shall be deemed to be covered by other rates and prices entered in the Bill of Quantities.
6. The whole cost of complying with the provisions of the Contract shall be included in the items provided in the Bill of Quantities, and where no Items are provided the cost shall be deemed to be distributed among the rates and prices entered for the related Item of work.
7. General directions and descriptions of work and materials are not necessarily repeated or summarized in the Bill of Quantities. References to the relevant sections of the contract documentation shall be made before entering rates of prices against each item in the Bill of Quantities.
8. The method of measurement of completed work for payment shall be in accordance with the HSR or as specified in the BOQ.

Errors will be corrected by the Employer for any arithmetic errors

Note : Where ever applicable, the interpretation of Items mentioned in the BOQ shall be as per HSR.

Construction / Upgradation of Roads Networks (Phase 1 & 2), Laying of Civic Infrastructure, Underground Cabling of HT/LT Transformers, Street Lighting, Landscaping Works etc. in ABD Faridabad Smart City with Defect Liability Period of Two Years and Operation & Maintenance of 5 Years.

Sno.	Ref.	Nos..	Description of Item	Unit	Quantity	Rate (Rs)	Amount (Rs)
			SITE CLEARANCE AND DISMANTLING				
1	Non SOR		Clearing and grubbing road land, embankment slope, Clearing jungle including uprooting of rank vegetation, grass, brush wood, trees and saplings of girth up to 30 cm measured at a height of 1 m above ground level and removal of rubbish up to a distance of 500m outside the periphery of the area cleared. as per Technical Specifications Clause 201of MoRTH.	Hect.	12.05		
2	HSR	8.5 B	Dismantling of Brick Masonry(In Cement)	Cum	2311.75		
3	HSR	8.2B	Dismantling of Stone Pitching/Stone Masonry	Cum	133.98		
4	Non SOR		Dismantling of Guide/Hand rails / Fencing /	Rmt	875.00		
5	HSR	8.6 d	Dismantling of Plain Cement Concrete (kerb)	Cum	578.08		
6	HSR	8.6 d	Dismantling of Plain Cement Concrete	Cum	60.23		
7	HSR	8.6e	Dismantling of Reinforced Cement Concrete including reinforcement	Cum	376.63		
8	Non SOR		Dismantling of Sub base / Base Course	Cum	9807.50		
9	Non SOR		Dismantling of Hume pipes of any dia.	Rmt	415.00		
10	Non SOR		Fencing/Railing of any type/material	Rmt	505.00		
11	Non SOR		Dismantling of Sign boards/bill boards (Small upto 2mx 2m)	Nos.	200.00		
12	Non SOR		Dismantling of Removal of electrical/telephone poles and lines	Nos.	185.00		
13	Non SOR		Dismantling of any type of flooring including footpath	Sqm	1803.00		
14	Non SOR		Dismantling of flexible pavement (bituminous courses) by mechanical means and disposal of dismantled material as per direction of Engineer-in-charge.	Cum	2676.80		
15	Non SOR		Disposal of building rubbish / malba / similar unserviceable, dismantled or waste materials by mechanical means, including loading, transporting, unloading to approved municipal dumping ground for lead up to 10 Km for all lifts,or as approved by Engineer-in-charge,	Cum	4760.09		

Sno .	Ref.	Nos..	Description of Item	Unit	Quantity	Rate (Rs)	Amount (Rs)
16	Non SOR		Taking out C.I. cover with frame from R.C.C. top slab of manholes of various sizes including demolishing of R.C.C. work manually/ by mechanical means and stacking of useful materials near the site and disposal of unserviceable materials within 500 Meters lead as per direction of Engineer-in-charge.	Nos.	116.00		
17	Non SOR		Taking out C.I. cover with frame from R.C.C. top slab of inspection chambers of various sizes including demolishing of R.C.C. work manually/ by mechanical means and stacking of useful materials near the site and disposal of unserviceable materials within 500 Meters lead as per direction of Engineer-in-charge.	Nos.	106.00		
			EARTHWORKS				
18	HSR	6.6	Earth work in excavation in foundations, trenches, etc.in all kinds of soils, Nos.t exceeding 2 Meters depth including dressing of bottom and sides of trenches, stacking the excavated soil, clear from the edge of excavation and subsequent filling around masonry, in 15 cm layers with compaction, including disposal of all surplus soil, as directed within a lead of 30 Meters	Cum	25413.19		
19	Non SOR		Earth work in excavation by mechanical means (Hydraulic excavator) / manual means over areas (exceeding 30cm in depth, 1.5m in width as well as 10 sqm on plan) including getting out and disposal of excavated earth, lead up to 5 km. and lift up to 1.5m,as directed by Engineer-in-Charge. -All kinds of soil	Cum	15107.89		
20	Non SOR		Earth work in excavation by mechanical means (Hydraulic excavator) / manual means over areas (exceeding 30 cm in depth, 1.5m in width as well as 10 sqm on plan) including- Ordinary Rock	Cum	1505.90		
21	Non SOR		Providing and Construction of embankment with approved materials obtained from roadway and drain excavation as per Technical Specifications Clause 305. MoRTH	Cum	535.00		
22	Non SOR		Providing and Construction of subgrade with approved materials from borrow areas as per Technical Specifications Clause 305 & 403 including all leads and lifts. Selected Earth (CBR Nos.t less than 8%)	Cum	15863.00		
23	Non SOR		Earthwork in filling of median/island area with selected earth as per Technical	Cum	6286.15		

Sno	Ref.	Nos..	Description of Item	Unit	Quantity	Rate (Rs)	Amount (Rs)
			Specifications Clause 407 of MoRTH - including all leads and lifts.				
			SUBBASE AND BASE COURSES				
24	Non SOR		Providing and laying Granular Sub Base (drainage layer) conforming to Grading V of Table 400.1 (MORT&H Rev 5th 2013 specification) of compacted thickness of 200 mm with specified graded stone metal and sand mixed in pugmill and laid with mechanical means spreading with motor grader and compacting with vibratory roller having minimum 80-100KN static weight to achieve desired density of 98% of MDD.	Cum	15668.30		
25	Non SOR		Providing and laying Wet Mix Macadam with paver finisher in specified thickness, each layer Nos.t exceeding 200 mm compacted thickness including premixing in pugmill/plant well graded crushed stone aggregate, with watering and spreading by mechanical means to required profile and compacting by vibratory roller of minimum 80 - 100 KN static weight to achieve desired density of 98% of MDD including all material, labour, machinery with all leads and lifts etc. complete as per Technical Specifications Clause 406 of MoRTH.	Cum	3911.00		
			Concrete Road				
26	Non SOR		Providing & laying dry lean concrete sub-base including coarse and fine aggregate to the specified gradation with all leads and lifts etc.(minimum cement 150 kg/cum) complete as per MORT&H specifications clause 601.	Cum	4507.50		
27	Non SOR		Providing & laying Pavement Quality Concrete of M-40 grade including 125micron thick impermeable plastic sheet membrane and fixing dowels, tie bars, seals for joints and finishing, with all leads and lifts complete as per MORT&H specifications clause 602.	Cum	9165.00		
			BITUMINOUS COURSES				
28	Non SOR		Providing and applying Prime Coat with bitumen emulsion RS-I bitumen emulsion confirming to IS 8887 for application of tack coat before application of binder course at rate of 0.7 kg per sq.m area as per Technical Specifications Clause 502 of MoRTH..	Sqm	49528.00		
29	Non SOR		Providing and applying Tack Coat with bitumen emulsion RS-I bitumen emulsion confirming to IS 8887 for	Sqm	76798.00		

Sno.	Ref.	Nos..	Description of Item	Unit	Quantity	Rate (Rs)	Amount (Rs)
			application of tack coat before application of binder course at rate of 0.27 kg per sq.m area as per Technical Specifications Clause 502 of MoRTH..				
30	Non SOR		Providing and laying Dense Graded Bituminous Macadam (DBM) course provided Grade II by wt of total mix as binder using VG-30, 4.5% for batch mix type hotmix plant and laying by sensor paver finisher including consolidation by roller as specified including providing and operating plant sensor paver and machinery, as per drawings and Technical Specifications Clause 507 of MoRTH..	Cum	3381.20		
31	Non SOR		Providing and laying of Bituminous concrete using aggregates as per gradation and percentage of bitumen for mixing shall be as arrived from mix design, provided in Nos. case bitumen percentage shall be less than 5.4% for Grade II by wt of total mix as binder using CRMB-55 by batch mix type hot mix plant and laying by sensor paver finisher including consolidation by rollers as specified including providing and operating plant, sensor paver and machinery, cost of fuel, oil, lubricant and labour charges including cost of aggregate and filler as per mix design etc. complete excluding applying tack coat emulsion) as per drawings and Technical Specifications Clause 507 of MoRTH.	Cum	3118.72		
			Cycle Track/Footpath/Kerb				
32	HSR	10.63	Design mix cement concrete of grade M-10 with minimum cement contents 220 Kg./cum in foundation and plinth.	Cum	237.50		
33	HSR	10.64	Design mix cement concrete of grade M-15 with minimum cement contents 315 Kg./cum in foundation and plinth.	Cum	2543.00		
34	HSR	10.65	Design mix cement concrete of grade M-20 with minimum cement contents 405 Kg./cum in foundation and plinth.	Cum	232.64		
35	HSR	10.66	Design mix cement concrete of grade M-25 with minimum cement contents 410 Kg./cum in foundation and plinth.	Cum	437.18		
36	HSR	10.67	Design mix cement concrete of grade M-30 with minimum cement contents 420 Kg./cum in foundation and plinth.	Cum	2022.50		
37	HSR	10.68	Design mix cement concrete of grade M-35 with minimum cement contents 430 Kg./cum in foundation and plinth.	Cum	56.00		

Sno .	Ref.	Nos..	Description of Item	Unit	Quantity	Rat e (Rs)	Amoun t (Rs)
38	HSR	18.22	Fe- 500 EQR TMT Steel bars RCC, works, where Nos.t including in the complete rate of RCC including bending, binding and placing in position complete.	Quinta l	215.55		
39	HSR	9.5	Centring and shuttering for faces of walls, partitions, retaining walls,well steining and the like (vertical or battering)including attached pilasters etc.	sqm	2773.33		
40	Non SOR		Design mix cement concrete of grade M-25 with minimum cement contents 410 Kg./cum in foundation and plinth. For Precast Slab of Drain work	Cum	33.75		
41	HSR	11.4	First class brick laid in cement sand mortar 1:4 in foundation and plinth.	Cum	82.25		
42	HSR	15.7	12 mm thick cement plaster 1:4	Sqm	750.00		
43	HSR	10.77	Precast cement concrete 1:2:4 with stone aggregate 20 mm Nominal size in Kerbs and the like items, finished smooth with 6 mm thick cement plaster 1:3 on exposed surface including from work, placing and fixing in position, complete at the ground level	Cum	1726.24		
44	HSR	16.24	Preparation of plastered or concrete surfaces for painting, including sand papering the surface, applying one coat of linseed oil and filling with approved quality filler, consisting of white lead, linseed oil, varnish and chalk mitti including finishing surface to the required finish, complete.	Sqm	18744.00		
45	HSR	16.25	Applying priming coat with cement primer in all shades on newly plastered or concrete exterior surfaces.	Sqm	18744.00		
46	HSR	16.26	Painting two coats with ready-mixed exterior paint in all shades on newly plastered or concrete surface of walls.	Sqm	18744.00		
47	Non SOR		Providing, Applying and finishing the top surface of concrete, in accordance with broadcasting of Bomanite Colour Hardener at the rate of 2.7 kgs/sq mtr. Floating the surface with different types of floaters, application of Release Agent at the rate of 0.113 kg/sq.mtr stamping the concrete with stamping tools, cleaning the surface with water and application of acrylic based Sealer for finishing. Our color hardeners and release agents have been tested for abrasion resistance and should have a depth of wear Nos.t greater than 0.05mm under BS 8204.	Sqm	14770.25		
48	Non SOR		Providing and Construction of subgrade with approved materials from borrow	Cum	1976.80		

Sno .	Ref.	Nos..	Description of Item	Unit	Quantity	Rat e (Rs)	Amoun t (Rs)
			areas as per Technical Specifications Clause 305 & 403 including all leads and lifts. Selected Earth (CBR Nos.t less than 8%)				
49	Non SOR		Providing and laying Granular Sub Base (drainage layer) conforming to Grading V of Table 400.1 (MORT&H Rev 5th 2013 specification) of compacted thickness of 200 mm with specified graded stone metal and sand mixed in pugmill and laid with mechanical means spreading with motor grader and compacting with vibratory roller having minimum 80-100KN static weight to achieve desired density of 98% of MDD.	Cum	1976.80		
			CONCRETE WORK				
50	HSR	10.64	Design mix cement concrete of grade M-15 with minimum cement contents 315 Kg./cum in foundation and plinth.	Cum	1975.49		
51	HSR	10.65	Design mix cement concrete of grade M-20 with minimum cement contents 410 Kg./cum in foundation and plinth.	Cum	19.50		
52	HSR	10.67	Design mix cement concrete of grade M-30 with minimum cement contents 420 Kg./cum in foundation and plinth.	Cum	1066.85		
53	HSR	9.5	Centring and shuttering for faces of walls, partitions, retaining walls,well steining and the like (vertical or battering)including attached pilasters etc.	Sqm	700.00		
54	HSR	18.22	Fe- 500 EQR TMT Steel bars RCC, works, where Not including in the complete rate of RCC including bending, binding and placing in position complete.	Quinta 1	231.82		
			INTERLOCKING BLOCKS				
55	HSR	10.158	Providing and laying 60mm thick interlocking paver blocks of all shapes and colours in design mix cement M-35 over a bed of 25mm thick fine sand complete in all respect.	Sqm	95269.90		
56	Non SOR		Providing and laying factory made chamfered edge 80 mm thick Cement Concrete grass paver blocks In foot path, park & lawns driveway or light & traffic parking etc. of required strength, thickness & size/ shape, made bytable vibratory method using PU mould, laid in required colour & pattern over 50mm thick compacted bed of course sand, compacting and proper embedding/laying of inter locking paver blocks into the sand bedding layer through vibratory compaction by using plate vibrator, filling the joints with sand	Sqm	2000.00		

Sno .	Ref.	Nos..	Description of Item	Unit	Quantity	Rate (Rs)	Amount (Rs)
			and cutting of paver blocks as per required size and pattern, finishing and sweeping extra sand, all complete as per manufacturer's specifications & direction of Engineer in-Charge.				
57	Non SOR		Providing, Applying and finishing the top surface of concrete, in accordance with broadcasting of Bomanite Color Hardener at the rate of 2.7 kgs/sq Meter Floating the surface with different types of floaters, application of Release Agent at the rate of 0.113 kg/sq.mtr stamping the concrete with stamping tools, cleaning the surface with water and application of acrylic based Sealer for finishing. Our color hardeners and release agents have been tested for abrasion resistance and should have a depth of wear Nos.t greater than 0.05mm under BS 8204.	Sqm	20498.00		
58	Non SOR		Providing and laying matt finished vitrified tile of size 300x300x9.8mm having with water absorption less than 0.5% and conforming to IS: 15622 of approved make in all colours and shades in for outdoor floors such as footpath, court yard, multi modals location etc., laid on 20mm thick base of cement mortar 1:4 (1cement : 4 coarse sand) in all shapes & patterns including grouting the joints with white cement mixed with matching pigments etc. complete as per direction of Engineer-in-Charge	Sqm	18117.00		
			OFC cable duct				
59	Non SOR		Cable Duct Across the Road -Providing and laying of a reinforced cement concrete pipe duct, 300 mm dia, NP2 across the road (new construction), extending from drain to drain in cuts and toe of slope to toe of slope in fills, constructing head walls at both ends, providing excavation & Backfillig a minimum fill of granular material over top and sides of RCC pipe as per IRC:98-1997, bedded on a 0.3 m thick layer of granular material free of rock pieces, outer to outer distance of pipe at least half dia of pipe subject to minimum 450 mm in case of double and triple row ducts, joints to be made leak proof, invert level of duct to be above higher than ground level to prevent entry of water and dirt, all as per IRC: 98 - 1997	Meter	747.00		

Sno.	Ref.	Nos..	Description of Item	Unit	Quantity	Rate (Rs)	Amount (Rs)
			and approved drawings.- Single Row for one utility service				
60	Non SOR		Cable Duct Across the Road -Providing and laying of a reinforced cement concrete pipe duct, 300 mm dia,NP2 across the road (new construction), extending from drain to drain in cuts and toe of slope to toe of slope in fills, constructing head walls at both ends,providing excavation & Backfillig a minimum fill of granular material over top and sides of RCC pipe as per IRC:98-1997, bedded on a 0.3 m thick layer of granular material free of rock pieces, outer to outer distance of pipe at least half dia of pipe subject to minimum 450 mm in case of double and triple row ducts, joints to be made leak proof, invert level of duct to be above higher than ground level to prevent entry of water and dirt, all as per IRC: 98 - 1997 and approved drawings- Double Row for two utility services	Meter	812.00		
			TRAFFIC SIGNS,MARKING & ROAD APPURTENANCES				
61	Non SOR		Providing and fixing of retro-reflectorised cautionary, mandatory and informatory sign as per IRC :67 made of encapsulated lens type reflective sheeting vide clause 801.3, fixed over aluminium sheeting, 1.5 mm thick supported on a mild steel angle iron post 75 mm x 75 mm x 6 mm firmly fixed to the ground by means of properly designed foundation with M15 grade cement concrete 45 cm x 45 cm x 60 cm, 60 cm below ground level as per approved drawing- Circular sign 600 dia.	Nos.	90.00		
62	Non SOR		Providing and fixing of retro-reflectorised cautionary, mandatory and informatory sign as per IRC :67 made of encapsulated lens type reflective sheeting vide clause 801.3, fixed over aluminium sheeting, 1.5 mm thick supported on a mild steel angle iron post 75 mm x 75 mm x 6 mm firmly fixed to the ground by means of properly designed foundation with M15 grade cement concrete 45 cm x 45 cm x 60 cm, 60 cm below ground level as per approved drawing- Circular sign 900 dia.	Nos.	11.00		

Sno .	Ref.	Nos..	Description of Item	Unit	Quantity	Rat e (Rs)	Amoun t (Rs)
63	Non SOR		Providing and fixing of retro-reflectoris ed cautionary, mandatory and informatory sign as per IRC :67 made of encapsulated lens type reflective sheeting vide clause 801.3, -Triangular sign 900 side.	Nos.	44.00		
64	PWD-HR.6.4		Providing and fixing of shoulder mounted sign boards of various sizes using Non- metallic micro prismatic retro reflective sheet conformin! to IRC: 67 -2012type IV HIP specification fixed on 3 mm thick Aluminium Composite Panel, having 0.5 mm thick Aluminium on both sides supported on Mild Steel Pipe leg post 80mm NB, 1.6 mm thick duly painted in alternative color of black and white embedded M -20 Grade concrete foundation of size 450 mm x 450 mm x 600 mm, complete as per drawings, Technical Specifications and as directed by Engineer-in-Charge.- Cautionary WARNING SIGNS:- 600 mm Equilateral Triangle	Nos.	135.00		
65	PWD-HR.6.6		Providing and fixing of shoulder mounted sign boards of various sizes using Non- metallic micro prismatic retro reflective sheet conformin! to IRC: 67 -2012type IV HIP specification fixed on 3 mm thick Aluminium Composite Panel, having 0.5 mm thick Aluminium on both sides supported on Mild Steel Pipe leg post 80mm NB, 1.6 mm thick duly painted in alternative color of black and white embedded M -20 Grade concrete foundation of size 450 mm x 450 mm x 600 mm, complete as per drawings, Technical Specifications and as directed by Engineer-in-Charge. MANDATORY/REGULATORY SIGN:- 600 mm High Octagon--STOP SIGN	Nos.	35.00		

Sno .	Ref.	Nos..	Description of Item	Unit	Quantity	Rate (Rs)	Amount (Rs)
66	Non SOR		Providing and fixing of retro-reflectorised cautionary, mandatory and informatory sign as per IRC :67 made of encapsulated lens type reflective sheeting vide clause 801.3, fixed over aluminium sheeting, 1.5 mm thick supported on a mild steel angle iron post 75 mm x 75 mm x 6 mm firmly fixed to the ground by means of properly designed foundation with M15 grade cement concrete 45 cm x 45 cm x 60 cm, 60 cm below ground level as per approved drawing- Facility Information signs 600mm x 450mm	Nos.	11.00		
67	Non SOR		Providing and fixing of retro-reflectorised cautionary, mandatory and informatory sign as per IRC :67 made of encapsulated lens type reflective sheeting vide clause 801.3, fixed over aluminium sheeting, 1.5 mm thick supported on a mild steel angle iron post 75 mm x 75 mm x 6 mm firmly fixed to the ground by means of properly designed foundation with M15 grade cement concrete 45 cm x 45 cm x 60 cm, 60 cm below ground level as per approved drawing- Information signs-square-600 x 600	Nos.	14.00		
68	Non SOR		Providing and fixing of retro-reflectorised cautionary, mandatory and informatory sign as per IRC :67 made of encapsulated lens type reflective sheeting vide clause 801.3, fixed over aluminium sheeting, 1.5 mm thick supported on a mild steel angle iron post 75 mm x 75 mm x 6 mm firmly fixed to the ground by means of properly designed foundation with M15 grade cement concrete 45 cm x 45 cm x 60 cm, 60 cm below ground level as per approved drawing- Facility Information signs-600 x 900 rectangle	Nos.	45.00		

Sno .	Ref.	Nos..	Description of Item	Unit	Quantity	Rate (Rs)	Amount (Rs)
69	Non SOR		Providing and fixing of retro-reflectorised cautionary, mandatory and informatory sign as per IRC :67 made of encapsulated lens type reflective sheeting vide clause 801.3, fixed over aluminium sheeting, 1.5 mm thick supported on a mild steel angle iron post 75 mm x 75 mm x 6 mm firmly fixed to the ground by means of properly designed foundation with M15 grade cement concrete 45 cm x 45 cm x 60 cm, 60 cm below ground level as per approved drawing- Facility Information signs900 x 300-rectangle	Nos.	110.00		
70	Non SOR		Providing and fixing of retro-reflectorised cautionary, mandatory and informatory sign as per IRC :67 made of encapsulated lens type reflective sheeting vide clause 801.3, fixed over aluminium sheeting, 1.5 mm thick supported on a mild steel angle iron post 75 mm x 75 mm x 6 mm firmly fixed to the ground by means of properly designed foundation with M15 grade cement concrete 45 cm x 45 cm x 60 cm, 60 cm below ground level as per approved drawing- Information signs--rectangle-1200x900	Nos.	42.00		
71	Non SOR		Providing and fixing of retro-reflectorised cautionary, mandatory and informatory sign as per IRC :67 made of encapsulated lens type reflective sheeting vide clause 801.3, fixed over aluminium sheeting, 1.5 mm thick supported on a mild steel angle iron post 75 mm x 75 mm x 6 mm firmly fixed to the ground by means of properly designed foundation with M15 grade cement concrete 45 cm x 45 cm x 60 cm, 60 cm below ground level as per approved drawing- Octogonal stop sign 900mm size	Nos.	30.00		

Sno.	Ref.	Nos..	Description of Item	Unit	Quantity	Rate (Rs)	Amount (Rs)
72	Non SOR		Providing and laying pavement marking with hot applied thermoplastic paints with Reflectorising Glass Beads on Bituminous Surface (Providing and laying of hot applied thermoplastic compound 2.5 mm thick including reflectorising glass beads @ 250 gms per sqm area, thickness of 2.5 mm is exclusive of surface applied glass beads as per IRC:35 .The finished surface to be level, uniform and free from streaks and holes.)(TYPE-2)conforming to ASTM D-36 / BS 3262 (Part-1) complete as per drawing and Technical Lane / centreline / edge marking / transverse and any other marking,Directional arrows, lettering etc. as per Drawing Nos.. 61 of MORT&H Type Design & Intersection	Sqm	20871.61		
73	Non SOR		Supplying and fixing Median Marker made through high intensity grade, injection-moulded, thermoplastic body with an isosceles trapezoidal structure of length, width and height Nos.t less than 15cm, 10 cm and 10cm respectively The Median Marker shall have fluorescent yellow colour retro-reflective sheeting of size Nos.t less than 8.5cm*8.5cm and with fully reflective micro prismatic cube corners as its retro-reflective elements and meets A STMD 4956 type IX specifications The retro-reflective sheeting shall be one or both sides of the Median Marker. The Median Markers shall be fixed by a combination of epoxy adhesive and grouting	Nos.	1071.00		
74	Non SOR		Pavement Marker (Cat Eyes) Moulded shank raised pavement markers made of polycarbonate and ABS moulded body and reflective panels with micro prismatic lens capable of providing internal reflection of the light entering the lens face and shall support a load of 16000 KG tested in accordance to ASTM D 4280 Type H and complying to specifications of Category A of MORTH Circular Nos. W/NH/33023/10-97-DO III dt. 11.06.1997. The height width and length shall Nos.t be exceed 50mm, 100mm and 100 mm and with minimum reflective area of 13 Sqcm. On each side and the slope to the base shall be 35+/- degree. The strength of detachment of the integrated cylindrical shanks, (of	Nos.	5310.00		

Sno .	Ref.	Nos..	Description of Item	Unit	Quantity	Rate (Rs)	Amount (Rs)
			diameter Nos.t less than 19+/-2 mm and height Nos.t less than 30+/- mm) from the body is to be a minimum value of 500 Kg. Fixing will be by drilling holes on the road for the shanks to go inside, without nails and using epoxy resin based adhesive as per manufacturer's recommendation and complete as directed by the engineer (of reputed make such as Avery Dennison/3M/etc.)				
75	Non SOR		Solar Stud: Supplying of Solar Raised Pavement Markers made of polycarbonate molded body with circular shape, solar powered, LED self illumination in active mode, 360 degree illumination and reflective panels with micro prismatic lens capable of providing total internal reflection of the light entering the lens face in passive mode. The marker shall support a load of 20000 kg tested in accordance to ASTM D 4280. The marker should be resistant to dust and water ingress according to IP 65 standards and should withstand temperatures in the range of 0 C to 70 C. Color of lighting could be provided in red or yellow (amber) as per requirement and typical frequency of blinking is 1 Hz. There should be current losses of less than 20 micro-amperes at 2.4 V in sleep-charging mode to enhance the life of the marker and a full charge should provide for a minimum autoNos.my of 50 hours. The height, width and length of the marker shall Nos.t be less than 10 mm x 100 mm x 100 mm. Also, the surface diameter of the marker shall Nos.t be less than 100 mm respectively. The weight of the marker shall Nos.t exceed 0.5 Kilograms. Pavement: Fixing will be by anchorage on the road surface for the shanks to go inside (or) as per manufacturer's recommended methodology without any damage to the road surface and strength, without nails and using epoxy resin based adhesive as per manufacturer's recommendation and complete as directed by the engineer. The Clause 804 of "Specifications for Roads And Bridge Works" (Fifth Revision) by the Ministry of Road Transport & Highways (MoRTH) and ASTM 4280-04 shall be referred.	Nos.	1473.00		

Sno	Ref.	Nos..	Description of Item	Unit	Quantity	Rate (Rs)	Amount (Rs)
76	Non SOR		Providing & fixing retro-reflective light bollards 1500 mm high as per site requirements, using Non-metallic micro prismatic retro reflective sheets conforming to IRC : 67-2012 type 4, HIP specification fixed on 3 mm thick aluminium composite material sheet as base having 0.5 mm thick aluminium on both sides having circular board of size 450mm dia, sheeting of blue back ground and white arrow. The order board will be of size 600 mm x 400 mm made up of high intensity retro-reflective sheeting type 4 fixed over aluminium composite panel sheet 3 mm thick both of the boards fixed on 80 mm NBdia 16 gauge M.S. pipe duly printed. The board to be fixed in CC 1:2:4 block of size 300x300x450mm.	Nos.	86.00		
77	Non SOR		Providing, fixing and erecting 50 mm dia(post) MS steel pipe railing duly painted on medium weight steel pipe 1.2 Meters high above ground with concrete foundation, 1.5 m centre to centre, with 25 mm vertical pipe 150 mm center to center as railing, complete as per approved drawings	Rmt	8760.00		
78	Non SOR		Vertical Graphics Ambient Signs Single sided duly fixed on RCC foundation approximately 3cum. The Single sided Vertical Graphics Ambient board shall be made out of internal structure by using SHS duly powder coated and clad with 4mm Aluminium Composite Panel. The top portion of circle of the Ambient sign logo shall be thermoformed from PET-G Sheet & rest of the front facilities shall be made out of plain Acrylic sheet/PET-G Sheet/Poly carbonate. The messages will be on digital printed on Type – XI Retro Reflective Sheeting which will be dimond grade and special translucent sheet and the same shall be pasted on front & back of the sign (printing standard should be ultra chrome GS-3 ink for outdoor application). Outdoor durability of ink should be minimum five years certified by OEM on reflective material.	Nos.	7.00		

Sno .	Ref.	Nos..	Description of Item	Unit	Quantity	Rat e (Rs)	Amoun t (Rs)
79	Non SOR		OVERHEAD SIGNS:- Providing and erecting overhead signs including gantry using Nos..n-metallic micro prismatic retro reflective sheet conforming toIRC:67-2012 Type IV Specification fixed on 4 mm thick Aluminium composite panels as base board with pressure –sensitive adhesive having 0.5 mm thick Aluminium on both sides Supported by MS pipe structure complete as per drawing ,Technical specifications and as directed by Engineer-in-charge.-Cantilever overhead sign (single Side) including gantry – sheet on one face (T/L Shaped) Size (5000x1500)	Nos.	15.00		
80	Non SOR		OVERHEAD SIGNS:- Providing and erecting overhead signs including gantry using Nos..n-metallic micro prismatic retro reflective sheet conforming toIRC:67-2012 Type IV Specification fixed on 4 mm thick Aluminium composite panels as base board with pressure –sensitive adhesive having 0.5 mm thick Aluminium on both sides Supported by MS pipe structure complete as per drawing ,Technical specifications and as directed by Engineer-in-charge.-Overhead sign Gantry (single sided) size (12000x1500)	Nos.	28.00		
81	Non SOR		Providing and fixing of retro-reflectorised cautionary, mandatory and informatory sign as per IRC :67 made of encapsulated lens type reflective sheeting vide clause 801.3, fixed over aluminium sheeting, 1.5 mm thick supported on a mild steel angle iron post 75 mm x 75 mm x 6 mm firmly fixed to the ground by means of properly designed foundation with M15 grade cement concrete 45 cm x 45 cm x 60 cm, 60 cm below ground level as per approved drawing- Information signs-- rectangle-1200x1800	Nos.	11.00		
			MISCELLANEOUS ITEMS				
82	Non SOR		Supply of Colour Record Photographs : soft copy in CD and two Colour Prints thereof mounted in album complete as per Technical Specifications Clause 125.	Nos.	3340.00		

Sno	Ref.	Nos..	Description of Item	Unit	Quantity	Rate (Rs)	Amount (Rs)
83	Non SOR		Supplying colour video CD ROM records during construction consisting of each set of edited master cassettes & CD with 4 copies each of cassetters & CD ROMs complete as per Technical Specifications Clause 126.	Set	60.00		
			STORM WATER SYSTEM				
84	Non SOR		Providing and laying Non-pressure NP2 class (light duty) R.C.C. pipes with collars jointed with stiff mixture of cement mortar in the proportion of 1:2 (1 cement : 2 fine sand) including testing of joints etc. complete: 150 mm dia. R.C.C. pipe	Rmt	5950.00		
85	Non SOR		Providing and laying Non Pressure NP-3 class (Medium duty) R.C.C.pipes including collars/spigot jointed with stiff mixture of cement mortar in the proportion of 1:2 (1 cement : 2 fine sand) including testing of joints etc. complete 600 mm dia RCC pipes. (Laying by manual/ machanical means)	Rmt	6360.00		
86	Non SOR		Providing and laying Non Pressure NP-3 class (Medium duty) R.C.C.pipes including collars/spigot jointed with stiff mixture of cement mortar in the proportion of 1:2 (1 cement : 2 fine sand) including testing of joints etc. complete 900 mm dia RCC pipes. (Laying by mannual/ machanical means)	Rmt	2380		
87	Non SOR		Providing and fixing factory made precast RCC perforated drain covers, having concrete of strength Not less than M-25, of size 1000 x 450x50 mm, reinforced with 8 mm dia four Nos. longitudinal & 9 Nos.cross sectional T.M.T. hoop bars, including providing 50 mm dia perforations @ 100 to 125 mm c/c, including providing edge binding with M.S. flats of size 50 mm x 1.6 mm complete, all as per direction of Engineer- in-charge.	Each	1752.00		
88	HSR	29.94	Providing and fixing SFRC MANHOLE COVERS AND FRAMES MARKED WITH IS:12592 including setting the same to correct lines and levels in 1:2 cement sand mortar over manhole including Carriage loading, unloading stacking handling rehandling etc. Complete in all respects to the satisfaction of Engineer-In-charge.- Type: Extra heavy Duty Set (EHD-35) 560 MM Clear opening	Each	1624.00		

Sno .	Ref.	Nos..	Description of Item	Unit	Quantity	Rat e (Rs)	Amoun t (Rs)
89	Non SOR		Extra depth for circular type manhole 1.22 m internal dia (at bottom) beyond 1.68 m to 2.29 m : With common burnt clay F.P.S. (Non modular) bricks of class designation 7.5	Rmt	456.00		
90	HSR	15.7	12 mm thick cement plaster 1:4	Sqm	297.17		
91	Non SOR		Providing orange colour safety foot rest of minimum 6 mm thick plastic encapsulated as per IS : 10910, on 12 mm dia steel bar conforming to IS: 1786, having minimum cross section as 23 mmx25 mm and over all minimum length 263 mm and width as 165 mm with minimum 112 mm space between protruded legs having 2 mm tread on top surface by ribbing or chequering besides necessary and adequate anchoring projections on tail length on 138 mm as per standard drawing and suitable to with stand the bend test and chemical resistance test as per specifications and having manufacture's permanent identification mark to be visible even after fixing, including fixing in manholes with 30x20x15 cm cement concrete block 1:3:6 (1 cement : 3 coarse sand : 6 graded stone aggregate 20 mm Nominal size) complete as per design.	Each	6618.00		
92	HSR	6.7	EARTH WORK IN EXCAVATION IN FOUNDATIONS, TRENCHES, OF UNDER GROUND STRUCTURES. SULLAGE DRAINS,ETC., AND OTHER SIMILAR WORKS IN ORDINARY SOIL INCLLUDING DRESSING of bottom and sides, to correct levels and templates, cutting of trees and bushes, dewatering of rain water, diversion of traffic, fixing and maintenance of caution boards, and night signals, cressing over trenches for access to houses, watching, stacking of excavated soil, clear from the edge of excavation, and subsequent filling, where required around masonry, in 15 cm layers, with compaction AND DISPOSAL OF SURPLUS SOIL AS DIRECTED WITHIN A LEAD OF 30 MeterS FOR DEPTH UPTO 2 MeterS BELOW NATURAL GROND LEVEL	cum	149315.0 2		

Sno .	Ref.	Nos..	Description of Item	Unit	Quantity	Rat e (Rs)	Amoun t (Rs)
93	HSR	6.9/(b)/(ii)	Excavation for pipeline running under pressure in tranchege and pits,in streets & lanes including trimming and dressing sides, leveling of beds of trenches to correct grade, cutting joint holes, cutting trees and bushes, etc., refilling consolidation and watering of refill, in 15 cm layers AND RESTORATION OF UNMETALLED OR UNPAVED SURFACE TO ITS ORIGINAL OR UNPAVED the cost of dewatering of rain water, diversion of traffic, night signals, fixing caution boards, crossing over trenches for access to the houses, watching, fencing, etc., AND DISPOSAL OF SURPLUS SOIL OUTSIDE AND INSIDE THE TOWN, INVOLVING LEAD UPTO ONE KM IN ORDINARY SOIL with timbering and shoring exceeding 1.5 Meterss depth, but upto 2.5 Meterss depth	cum	27922.44		
94	HSR	6.9/ (b)/ (iii)	Excavation for pipeline running under pressure in tranchege and pits,in streets & lanes including trimming and dressing sides, leveling of beds of trenches to correct grade, cutting joint holes, cutting trees and bushes, etc., refilling consolidation and watering of refill, in 15 cm layers AND RESTORATION OF UNMETALLED OR UNPAVED SURFACE TO ITS ORIGINAL OR UNPAVED the cost of dewatering of rain water, diversion of traffic, night signals, fixing caution boards, crossing over trenches for access to the houses, watching, fencing, etc., AND DISPOSAL OF SURPLUS SOIL OUTSIDE AND INSIDE THE TOWN, INVOLVING LEAD UPTO ONE KM IN ORDINARY SOIL with timbering and shoring exceeding 2.5 Meterss depth, but upto 3.00 Meterss depth	cum	13207.09		
95	HSR	6.10/ (b)	EXCAVATION, OF TRENCHES IN STREETS, LANES OR IN OPEN AREAS FOR STROM SEWER, SEWERS RUNNING BY GRAVITY AND MANHOLES TO FULL DEPTHS AS SHOWN IN DRAWINGS INCLUDING SHORING, TIMBERING OF POLING BOARDS,FRAME SYSTEM TYPE, dressing to correct sections and dimensions, according to	cum	7614.19		

Sno .	Ref.	Nos..	Description of Item	Unit	Quantity	Rat e (Rs)	Amoun t (Rs)
			templates and levels, dewatering, provision for diversion of traffic, cutting trees and bushes, etc. night signals, profiles, pegs, sight rails, boning roads, crossing over trenches for access to the houses, watching, fencing etc., fixing and maintenance of caution boards, refilling of trenches, watering of refill, in 15 cm layers, ramming and restoration of unmetalled or unpaved surface to original condition AND REMOVAL OF SURPLUS SOIL, FROM SITE OF WORK, UPTO A LEAD OF 1 KM IN ORDINARY SOIL for depths of excaution exceeding 3 meters, but Nos. t exceeding 4.5 Meters.				
96	HSR	18.22	Fe- 500 EQR TMT Steel bars RCC, works, where Not including in the complete rate of RCC including bending, binding and placing in position complete.	Quinta l	50528.70		
97	HSR	10.63	Design mix cement concrete of grade M-10 with minimum cement contents 220 Kg./cum in foundation and plinth. - PCC below pipe	Cum	297.90		
98	HSR	10.64	Design mix cement concrete of grade M-15 with minimum cement contents 315 Kg./cum in foundation and plinth. For Storm water Duct.	Cum	5192.38		
99	HSR	10.66	Design mix cement concrete of grade M-25 with minimum cement contents 410 Kg./cum in foundation and plinth. For Storm water Duct.	Cum	34882.64		
100	HSR	9.7	Centring and shuttering for sides and soffits of beams haunchings, griders, bressumers and lintels.-Slab shuttering Soffit For Storm water Duct.	Sqm	118310.26		
101	HSR	9.6	Centring and shuttering for faces of walls, partitions, retaining walls, well steining and the like (vertical or battering) including attached pilasters etc. when curved -Wall .shuttring both side - for Storm water Duct	Sqm	105268.57		
102	Non SOR		providing and fixing Kerb Inlet in storm water drain 450mm wide X 150mm height	Nos.	264.00		
			SEWERAGE SYSTEM				
103	Non SOR		Providing and laying Non-pressure NP2 class (light duty) R.C.C. pipes with collars jointed with stiff mixture of cement mortar in the proportion of 1:2 (1 cement : 2 fine sand) including testing of joints etc. complete: 150 mm dia. R.C.C. pipe	Rmt	100.00		

Sno .	Ref.	Nos..	Description of Item	Unit	Quantity	Rat e (Rs)	Amoun t (Rs)
104	Non SOR		Supplying,fixing and laying Non-pressure NP2 class (Medium duty) R.C.C. pipes with collars jointed with stiff mixture of cement mortar in the proportion of 1:2 (1 cement : 2 fine sand) including testing of joints etc. complete -: 250 mm Dia. R.C.C. PIPE	Rmt	1830.00		
105	Non SOR		Providing and laying S&S Centrifugally Cast (Spun) / Ductile Iron Pipes conforming to IS : 8329 : 450 mm dia Ductile Iron Class K-9 pipes	Rmt	700.00		
106	Non SOR		Supplying,fixing and laying Non-pressure NP3 class (Medium duty) R.C.C. pipes with collars jointed with stiff mixture of cement mortar in the proportion of 1:2 (1 cement : 2 fine sand) including testing of joints etc. complete -: 450 mm Dia. R.C.C. pipe,	Meter	1400.00		
107	HSR	29.95	Providing salt glazed stoneware pipes grade A in standard Length of 600 mm each pipe Marked with IS :651 and their lowering cutting , jointing & testing including the Cost of Jointing Material as well as carriage ,loading ,unloading ,stacking ,handling , rehandling etc Complete inall respects to the Satisfaction to the Engineer in Charge . (300 Mm internal diameter)	Rmt	500.00		
108	Non SOR		Supplying,fixing and laying Non-pressure NP3 class (Medium duty) R.C.C. pipes with collars jointed with stiff mixture of cement mortar in the proportion of 1:2 (1 cement : 2 fine sand) including testing of joints etc. complete -: 600 mm Dia. R.C.C. pipe,	Rmt	500.00		
109	Non SOR		Supplying,fixing and laying Non-pressure NP3 class (Medium duty) R.C.C. pipes with collars jointed with stiff mixture of cement mortar in the proportion of 1:2 (1 cement : 2 fine sand) including testing of joints etc. complete -: 600 mm Dia. R.C.C. pipe,Including excavation, PCC construction of chamber and all relevant work complete of shifting of Sewerage system.	Rmt	1970.00		
110	HSR	30.114 (c)	Providing and fixing position gully traps fixedin cement concrete 1:4:8 complete WITH H.C.I.GRATING 150 MM X 150 MM Cast Iron cover weight approximate 7.26 K.G. and frame clear opening 300 MM x 300 MM and outside size 330 MM x 330 MM AND chamber includes cost of all brick work in CEMENT MORTAR 1:5 CEMENT CONCRETE	each	20.00		

Sno .	Ref.	Nos..	Description of Item	Unit	Quantity	Rate (Rs)	Amount (Rs)
			1:8:16 IN FOUNDATIONS, AND CEMENT CONCRETE 1:2:4 IN COPING around C.I. cover and frame etc. with three coats of black bitumastic superior PAINT of approved manufacture on all C.I. work AS PER STANDARD DESIGN, minimum depth of water should be 150mm with a minimum seal 50mm. 150 mm internal diameter S.W. gully trap				
111	HSR	29.84	CONSTRUCTION BRICK MASONRY INSPECTION CHAMBER SIZES AS GIVEN BELOW UPTO 0.60 Meter AVERAGE DEPTH in cement mortar 1:5 LIME CONCRETE with 40 percent lime mortar 2:3 in foundation cement concrete 1:2:4 BENCHING 12mm THICK CEMENT PLASTER 1:2 with a floating coat of 1mm thick of neat cement R.C.C.1:2:4 SLAB 100mm THICK /C.C.TOPPING 50 mm THICK WITH 455 MMx455MM/455MMx610MM INSIDE LIGHT DUTY C.I.INSPECTION CHAMBER COVER AND FRAME weight as per I.S.I. specification painted WITH 3 COATS OF black bitumastic superior paint complete as per standard design. (b) Size 450 mm X 600 mm inside (with 455 mm x 610 mm cover and frame single seal pattern I weighing 38 kg with C.C. topping)	each	200.00		
112	HSR	29.94	Providing and fixing SFRC MANHOLE COVERS AND FRAMES MARKED WITH IS:12592 including setting the same to correct lines and levels in 1:2 cement sand mortar over manhole including Carriage loading, unloading stacking handling rehandling etc. Complete in all respects to the satisfaction of Engineer-In-charge.- Type: Extra heavy Duty Set (EHD-35) 560 MM Clear opening	each	198.00		
113	Non SOR		Providing orange colour safety foot rest of minimum 6 mm thick plastic encapsulated as per IS : 10910, on 12 mm dia steel bar conforming to IS: 1786, having minimum cross section as 23 mmx25 mm and over all minimum length 263 mm and width as 165 mm with minimum 112 mm space between protruded legs having 2 mm tread on top	each	1852.00		

Sno .	Ref.	Nos..	Description of Item	Unit	Quantity	Rate (Rs)	Amount (Rs)
			surface by ribbing or chequering besides necessary and adequate anchoring projections on tail length on 138 mm as per standard drawing and suitable to withstand the bend test and chemical resistance test as per specifications and having manufacture's permanent identification mark to be visible even after fixing, including fixing in manholes with 30x20x15 cm cement concrete block 1:3:6 (1 cement : 3 coarse sand : 6 graded stone aggregate 20 mm Nos. minimal size) complete as per design.				
114	HSR	6.7	EARTH WORK IN EXCAVATION IN FOUNDATIONS, TRENCHES, OF UNDER GROUND STRUCTURES. SULLAGE DRAINS, ETC., AND OTHER SIMILAR WORKS IN ORDINARY SOIL INCLUDING DRESSING of bottom and sides, to correct levels and templates, cutting of trees and bushes, dewatering of rain water, diversion of traffic, fixing and maintenance of caution boards, and night signals, crossing over trenches for access to houses, watching, stacking of excavated soil, clear from the edge of excavation, and subsequent filling, where required around masonry, in 15 cm layers, with compaction AND DISPOSAL OF SURPLUS SOIL AS DIRECTED WITHIN A LEAD OF 30 MeterS FOR DEPTH UPTO 2 MeterS BELOW NATURAL GROND LEVEL upto 1.5 Meterss depth	cum	12761.17		
115	HSR	6.7	EXCAVATION FOR PIPELINES RUNNING UNDER PRESSURE IN TRENCHES AND PITS, IN STREETS & LANES including trimming and dressing sides, leveling of beds of trenches to correct grade, cutting joint holes, cutting trees and bushes, etc., refilling consolidation and watering of refill, in 15 cm layers AND RESTORATION OF UNMETALLED OR UNPAVED SURFACE TO ITS ORIGINAL OR UNPAVED the cost of dewatering of rain water, diversion of traffic, night signals, fixing caution boards, crossing over trenches for access to the houses, watching, fencing, etc., AND DISPOSAL OF SURPLUS SOIL OUTSIDE AND INSIDE THE TOWN,	cum	5485.71		

Sno .	Ref.	Nos..	Description of Item	Unit	Quantity	Rate (Rs)	Amount (Rs)
			INVOLVING LEAD UPTO ONE KM IN ORDINARY SOIL with timbering and shoring exceeding 1.5 Meters depth, but upto 2.25 Meters depth				
116	HSR	6.9/ (b)/ (iii)	Excavation for pipeline running under pressure in tranchege and pits,,in streets & lanes including trimming and dressing sides, leveling of beds of trenches to correct grade, cutting joint holes, cutting trees and bushes, etc., refilling consolidation and watering of refill, in 15 cm layers AND RESTORATION OF UNMETALLED OR UNPAVED SURFACE TO ITS ORIGINAL OR UNPAVED the cost of dewatering of rain water, diversion of traffic, night signals, fixing caution boards, crossing over trenches for access to the houses, watching, fencing, etc., AND DISPOSAL OF SURPLUS SOIL OUTSIDE AND INSIDE THE TOWN, INVOLVING LEAD UPTO ONE KM IN ORDINARY SOIL with timbering and shoring exceeding 2.5 Meters depth, but upto 3.00 Meters depth	cum	3024.92		
117	Non SOR		Making connection of drain or sewer line with existing manhole including breaking into and making good the walls, floors with cement concrete 1:2:4 mix (1 cement : 2 coarse sand : 4 graded stone aggregate 20 mm Nos.minal size) cement plastered on both sides with cement mortar 1:3 (1 cement : 3 coarse sand), finished with a floating coat of neat cement and making necessary channels for the drain etc. complete : For pipes 250 to 300 mm diameter	each	80.00		
118	Non SOR		Constructing brick masonry circular manhole 1.52 m internal dia at bottom and 0.56 m dia at top in cement mortar 1:4 (1 cement : 4 coarse sand) inside cement plaster 12 mm thick with cement mortar 1:3 (1cement : 3 coarse sand) finished with a floating coat of neat cement, foundation concrete 1:3:6 (1 cement : 3 coarse sand : 6 graded stone aggregate 40 mm Nominal size) and making necessary channel in cement concrete 1:2:4 (1 cement : 2 coarse sand : 4 graded stone aggregate 20 mm Nominal size) finished with a floating coat of neat cement, all complete as per	Each	124.00		

Sno.	Ref.	Nos..	Description of Item	Unit	Quantity	Rate (Rs)	Amount (Rs)
			standard design : 2.30 m deep with SFRC Cover and frame (heavy duty HD-20 grade designation) 560 mm internal diameter conforming to I.S. 12592, total weight of cover and frame to be Nos.t less than 182 kg. fixed in cement concrete 1:2:4 (1 cement : 2 coarse sand : 4 graded stone aggregate 20 mm Nominal size) including centering, shuttering all complete.(Excavation, foot rests and 12 mm thick cement plaster at the external surface shall be paid for separately) : With common burnt clay F.P.S. (Non modular) bricks of class designation 7.5				
119	Non SOR		Extra depth for circular type manhole 1.52 m internal dia (at bottom) beyond 2.30 m- : With common burnt clay F.P.S. (Non modular) bricks of class designation 7.5	Rmt.	315.00		
120	HSR	15.76	12 mm thick cement plaster damp proof course 1:3 with 2 coats of bitumen at 1.65 kg per sqm laid hot and sanded.	Sqm	1723.86		
121	HSR	10.63	Design mix cement concrete of grade M-10 with minimum cement contents 220 Kg./cum in foundation and plinth. - PCC below pipe	Cum	323.00		
122	Non SOR		Supply, installation, testing and commissioning of continuous duty submersible centrifugal Non-clogging drainage pumps complete with 3 phase motor, level sensor, control panel , Valves , NRV & Y-strainers with all necessary protection and mechanical seal etc with Cabling upto Control Panel etc complete accessories .Vendor to submit proposed pump model with duty curve,Flow:6250 LPM,Head : 50 Meter,Solid Handling : 40 MM,Purpose : Sewage Pump from Sector 21 - A.MOC : CI body / impeller & shaft (2Working +1 Standby)	Nos.	3.00		
			WATER SUPPLY SYSTEM				
123	Non SOR		Providing and laying S&S Centrifugally Cast (Spun) / Ductile Iron Pipes conforming to IS : 8329 : 100 mm dia Ductile Iron Class K-7 pipes	Meter	2160.00		
124	Non SOR		Providing and laying S&S Centrifugally Cast (Spun) / Ductile Iron Pipes conforming to IS : 8329 : 150 mm dia Ductile Iron Class K-7 pipes	Meter	2070.00		

Sno	Ref.	Nos..	Description of Item	Unit	Quantity	Rate (Rs)	Amount (Rs)
125	Non SOR		Providing and laying S&S Centrifugally Cast (Spun) / Ductile Iron Pipes conforming to IS : 8329 : 200 mm dia Ductile Iron Class K-7 pipes	Meter	2385.00		
126	Non SOR		Providing and laying S&S Centrifugally Cast (Spun) / Ductile Iron Pipes conforming to IS : 8329 : 250 mm dia Ductile Iron Class K-7 pipes	Meter	370.00		
127	Non SOR		Providing and laying S&S Centrifugally Cast (Spun) / Ductile Iron Pipes conforming to IS : 8329 : 300 mm dia Ductile Iron Class K-7 pipes	Meter	1105.00		
128	Non SOR		Providing and laying S&S Centrifugally Cast (Spun) / Ductile Iron Pipes conforming to IS : 8329 : 450 mm dia Ductile Iron Class K-7 pipes	Meter	230.00		
129	Non SOR		Providing and fixing C.I. sluice valves (with cap) complete with bolts, nuts, rubber insertions etc. (the tail pieces if required will be paid separately) : 100 mm diameter ,Class II	Nos.	13.00		
130	Non SOR		Providing and fixing C.I. sluice valves (with cap) complete with bolts, nuts, rubber insertions etc. (the tail pieces if required will be paid separately) : 150 mm diameter ,Class II	Nos.	11.00		
131	Non SOR		Providing and fixing C.I. sluice valves (with cap) complete with bolts, nuts, rubber insertions etc. (the tail pieces if required will be paid separately) : 200 mm diameter ,Class II	Meter	4.00		
132	Non SOR		Providing and fixing C.I. sluice valves (with cap) complete with bolts, nuts, rubber insertions etc. (the tail pieces if required will be paid separately) : 250 mm diameter ,Class II	Meter	1.00		
133	Non SOR		Providing and fixing C.I. sluice valves (with cap) complete with bolts, nuts, rubber insertions etc. (the tail pieces if required will be paid separately) : 300 mm diameter ,Class II	Nos.	8.00		
134	Non SOR		Providing and laying Double Flanged (Screwed/ Welded) Centrifugally (Spun) Ductile Iron Pipes of Class K - 9 conforming to IS : 8329 : 250 mm dia Ductile Iron Double Flanged	Meter	2974.00		

Sno .	Ref.	Nos..	Description of Item	Unit	Quantity	Rate (Rs)	Amount (Rs)
135	HSR	28.10	Providing and fixing Cast Iron double flanged swing check type reflux (Non return) valves PN-1.6 marked with IS:5312 including nuts and bolt marked with IS:1363, Rubber sheet marked with IS :638 etc. carriage loading , unloading stacking handling, re-handling etc. complete in all respect to the satisfaction of Engineer in-Charge(Makes AARKO, VENUS, LEADER, BIR, PANJA, UPADHAY).- 250 mm diameter	each	15.00		
136	Non SOR		Constructing masonry Chamber 90x90x100 cm inside, in brick work in cement mortar 1:4 (1 cement : 4 coarse sand) for sluice valve, with C.I. surface box 100 mm top diameter, 160 mm bottom diameter and 180 mm deep (inside) with chained lid and RCC top slab 1:2:4 mix (1 cement : 2 coarse sand : 4 graded stone aggregate 20 mm Nos.minal size), i/c necessary excavation, foundation concrete 1:5:10 (1 cement : 5 fine sand : 10 graded stone aggregate 40 mm Nominal size) and inside plastering with cement mortar 1:3 (1 cement : 3 coarse sand) 12 mm thick, finished with a floating coat of neat cement complete as per standard design :With common burnt clay F.P.S.(Non modular) bricks of class designation 7.5	each	28.00		
137	HSR	6.7	EARTH WORK IN EXCAVATION IN FOUNDATIONS, TRENCHES, OF UNDER GROUND STRUCTURES. SULLAGE DRAINS,ETC., AND OTHER SIMILAR WORKS IN ORDINARY SOIL INCLLUDING DRESSING of bottom and sides, to correct levels and templates, cutting of trees and bushes, dewatering of rain water, diversion of traffic, fixing and maintenance of caution boards, and night signals, cressing over trenches for access to houses, watching, stacking of excavated soil, clear from the edge of excavation, and subsequent filling, where required around masonry, in 15 cm layers, with compaction AND DISPOSAL OF SURPLUS SOIL AS DIRECTED WITHIN A LEAD OF 30 MeterS FOR DEPTH UPTO 2 MeterS BELOW NATURAL GROND LEVEL	Cum	8386.10		

Sno .	Ref.	Nos..	Description of Item	Unit	Quantity	Rat e (Rs)	Amoun t (Rs)
138	HSR	29.94	Providing and fixing SFRC MANHOLE COVERS AND FRAMES MARKED WITH IS:12592 including setting the same to correct lines and levels in 1:2 cement sand mortar over manhole including Carriage loading, unloading stacking handling rehandling etc. Complete in all respects to the satisfaction of Engineer-In-charge.- Type: Extra heavy Duty Set (EHD-35) 560 MM Clear opening	each	28.00		
139	HSR	10.64	Design mix cement concrete of grade M-15 with minimum cement contents 315 Kg./cum in foundation and plinth.	Cum	20.70		
			UTILITY DUCT LINE				
140	HSR	6.7	EARTH WORK IN EXCAVATION IN FOUNDATIONS, TRENCHES, OF UNDER GROUND STRUCTURES. SULLAGE DRAINS,ETC., AND OTHER SIMILAR WORKS IN ORDINARY SOIL INCLLUDING DRESSING of bottom and sides, to correct levels and templates, cutting of trees and bushes, dewatering of rain water, diversion of traffic, fixing and maintenance of caution boards, and night signals, cressing over trenches for access to houses, watching, stacking of excavated soil, clear from the edge of excavation, and subsequent filling, where required around masonry, in 15 cm layers, with compaction AND DISPOSAL OF SURPLUS SOIL AS DIRECTED WITHIN A LEAD OF 30 MeterS FOR DEPTH UPTO 2 MeterS BELOW NATURAL GROND LEVEL	cum	17336.60		
141	HSR	29.93	Providing, lowering, laying, cutting (cut surface to be uniformity finished) jointing with rubber rings marked with – IS: 5382 and testing of SPIGOT AND SOCKETED RCC NP2 MARKED WITH IS:458-1988 and specials into trenches for all depths including carriage, loading, unloading, staking, handling, rehandling,etc. complete in all respects to the satisfaction to the Engineer-in-charge. 300 mm dia. R.C.C. pipe	per Meter	23130.00		
142	Non SOR		Constructing brick masonry manhole in cement mortar 1:4 (1 cement : 4 coarse sand) with R.C.C. top slab with 1:2:4 mix (1 cement : 2 coarse sand : 4 graded stone aggregate 20 mm Nominal size),foundation concrete 1:4:8 mix (1	each	560.00		

Sno .	Ref.	Nos..	Description of Item	Unit	Quantity	Rat e (Rs)	Amoun t (Rs)
			<p>cement : 4 coarse sand : 8 graded stone aggregate 40 mm Nominal size), inside plastering 12 mm thick with cement mortar 1:3 (1 cement : 3 coarse sand) finished with floating coat of neat cement and making channels in cement concrete 1:2:4 (1cement : 2 coarse sand : 4 graded stone aggregate 20 mm Nominal size) finished with a floating coat of neat cement complete as per standard design : Inside size 90x80 cm and 45 cm deep including C.I. cover with frame (light duty) 455x610 mm internal dimensions, total weight of cover and frame to be Nos.t less than 38 kg (weight of cover 23 kg and weight of frame 15 kg) : -With common burnt clay F.P.S. (Non modular) bricks of class designation 7.5</p>				
143	HSR	29.94	<p>Providing and fixing SFRC MANHOLE COVERS AND FRAMES MARKED WITH IS:12592 including setting the same to correct lines and levels in 1:2 cement sand mortar over manhole including Carriage loading, unloading stacking handling rehandling etc. Complete in all respects to the satisfaction of Engineer-In-charge.- Type: Extra heavy Duty Set (EHD-35) 560 MM Clear opening</p>	each	560.00		
			DISMANTLING				
144	HSR	8.6 d	Dismantling of Plain Cement Concrete	Cum	1007.60		
145	HSR	8.6e	Dismantling of Reinforced Cement Concrete including reinforcement	Cum	5991.60		
146	Non SOR		Disposal of building rubbish / malba / similar unserviceable, dismantled or waste materials by mechanical means, including loading, transporting, unloading to approved municipal dumping ground or as approved by Engineer-in-charge, beyond 50 m initial lead, for all leads including all lifts involved.	Cum	6999.20		
147	Non SOR		Disposal of building rubbish / malba / similar unserviceable, dismantled or waste materials by mechanical means, including loading, transporting, unloading to approved municipal dumping ground for lead up to 10 Km for all lifts, or as approved by Engineer-in-charge,	Cum	6501.00		

Sno	Ref.	Nos..	Description of Item	Unit	Quantity	Rate (Rs)	Amount (Rs)
			ELECTRICAL WORKS				
			Under Ground Cabling & Electrical works(HT & LT)				
148	DHBVN (Gurgaon)	B 10	Supply, Installation, Testing and commissioning of Outdoor type, 11kV SF6 type, extensible and motorized , 3 way smart Ring Main Unit (RMU) complete 1 VCB and 2 LBS and Auxillary transformer, FPI but without FRTU as per Nigam's technical specification Nos.. CSC-117/R-1/DH/UH/P&D/2016-17 with latest amendments. The RMU shall have complete wiring and capability to connect /integrate the FRTU in future for enabling the SCADA functionality	Nos.	105.00		
149	DHBVN (Gurgaon)	B 11	Supply, Installation, Testing and commissioning of Outdoor type, 11kV SF6 type, extensible and motorized, 2 way smart Ring Main Unit (RMU) complete 2 LBS and Auxillary transformer, FPI but without FRTU as per Nigam's technical specification Nos.. CSC-117/R-1/DH/UH/P&D/2016-17 with latest amendments. The RMU shall have complete wiring and capability to connect /integrate the FRTU in future for enabling the SCADA functionality	Nos.	12.00		
150	DHBVN (Gurgaon)	B 13	Supply, Installation, Testing and commissioning of Outdoor type, 11kV SF6 type, extensible and motorized, 1 way smart Ring Main Unit (RMU) complete LBS and Auxillary transformer, FPI but without FRTU as per Nigam's technical specification Nos.. CSC-117/R-1/DH/UH/P&D/2016-17 with latest amendments. The RMU shall have complete wiring and capability to connect /integrate the FRTU in future for enabling the SCADA functionality	Nos.	12.00		
151	Non SOR		Supply, Installation, Testing and commissioning of 11kV, 630A, 20kA/3-sec Nos.n extensible 2 module set (Direct Cable Incoming Module and Load Break Switch Module for outgoing cable) as per IEC standard, compact switchgear suitable for Outdoor installation with IP67 SF6 tank, interlocking in Isolator switch and Earth switch, Fault pasage Indicator, Capacitive voltage indications, cable bushing and Terminal Protector Boots for covering cable termination.	Nos.	30.00		

Sno .	Ref.	Nos..	Description of Item	Unit	Quantity	Rate (Rs)	Amount (Rs)
			Outdoor Transformer				
152	DHBVN	8.3	630KVA, 3 phase, 11kV/433-250V oil immerse, Naturally cooled copper wound outdoor type distribution transformer as per latest Nigam technical specification with ammendment relavent ISS with latest ammendments. (including 1 Nos.. spare)	Nos.	71.00		
153	DHBVN	8.4	990KVA, 3 phase, 11kV/433-250V oil immerse, Naturally cooled copper wound outdoor type distribution transformer as per latest Nigam technical specification with ammendment relavent ISS with latest ammendments. (including 1 Nos.. spare)	Nos.	52.00		
154	DHBVN	C 7	Erection of Transformer on Plinth above 500KVA to 1000KVA 11/0.4 complete in all respect including placing of transformer on plinth, Earthing of Transformer- 2 Nos., Making connection to transformer.	Nos.	105.00		
155	DHBVN	C 5	Erection of cable box with fitting	Each	210.00		
			Outdoor LT Feeder Pillar				
156	DHBVN (Gurgaon)	4 a	Supply, Installation, Testing and commissioning of 6 way distribution feeder pillar with 1 Nos.. ACB, 4 pole, 3 ph, 415V, 1600A for incoming and 5 Nos.. outgoing MCCB 4 pole , 3 phase, 415V, 400A rating type, metering arrangement on incomer suitable for outdoor installation, in accordance with technical specification.	Nos.	43.00		
157	DHBVN (Gurgaon)	4 b	Supply, Installation, Testing and commissioning of 5 way distribution feeder pillar with 1 Nos.. ACB, 4 pole, 3 ph, 415V, 1250A for incoming and 4 Nos.. outgoing MCCB 4 pole , 3 phase, 415V, 400A rating type, metering arrangement on incomer suitable for outdoor installation, in accordance with technical specification	Nos.	62.00		
158	Non SOR		Supply, Installation, Testing and commissioning of outdoor type distribution feeder pillar with Al busbar, IEC 60947 compliant breakers, '1 Nos.. 400A 35kA TPN MCCB, 3 ph, 415 V' as incomer and '5 Nos. 80A 35kA TPN MCCB' as outgoing feeders, with all interconnections and in accordance with technical spec of DHBVN.	Nos.	33.00		

Sno.	Ref.	Nos..	Description of Item	Unit	Quantity	Rate (Rs)	Amount (Rs)
159	Non SOR		Supply, Installation, Testing and commissioning of outdoor type distribution feeder pillar with Al busbar, IEC 60947 compliant breakers, '1 Nos.. 400A 35kA TPN MCCB, 3 ph, 415 V' as incomer and '10 Nos. 40A 35kA TPN MCCB' as outgoing feeders, with all interconnections and in accordance with technical spec of DHBVN.	Nos.	42.00		
160	Non SOR		Supply, Installation, Testing and commissioning of outdoor type distribution feeder pillar with Al busbar, IEC 60947 compliant breakers, '1 Nos.. 400A 35kA TPN MCCB, 3 ph, 415 V' as incomer and '3 Nos. 80A 35kA TPN MCCB' and '4 Nos. 40A 35kA TPN MCCB' as outgoing feeders, with all interconnections and in accordance with technical spec of DHBVN.	Nos.	40.00		
161	Non SOR		Supply, Installation, Testing and commissioning of outdoor type distribution feeder pillar with Al busbar, IEC 60947 compliant breakers, '1 Nos.. 400A 35kA TPN MCCB, 3 ph, 415 V' as incomer and '5 Nos. 40A 35kA TPN MCCB & 15 Nos.. (5 Nos./ph) 40A 10kA SPN MCB' as outgoing feeders, with all interconnections and in accordance with technical spec of DHBVN.	Nos.	39.00		
162	Non SOR		Supply, Installation, Testing and commissioning of outdoor type distribution feeder pillar with Al busbar, IEC 60947 compliant breakers, '1 Nos.. 400A 35kA TPN MCCB, 3 ph, 415 V' as incomer and '8 Nos. 40A 35kA TPN MCCB & 6 Nos.. (2 Nos./ph) 40A 10kA SPN MCB' as outgoing feeders, with all interconnections and in accordance with technical spec of DHBVN.	Nos.	38.00		
163	Non SOR		Supply, Installation, Testing and commissioning of outdoor type distribution feeder pillar with Al busbar, IEC 60947 compliant breakers, '1 Nos.. 400A 35kA TPN MCCB, 3 ph, 415 V' as incomer and '30 Nos.. (10 Nos./ph) 40A 10kA SPN MCB' as outgoing feeders, with all interconnections and in accordance with technical spec of DHBVN.	Nos.	47.00		

Sno	Ref.	Nos..	Description of Item	Unit	Quantity	Rate (Rs)	Amount (Rs)
164	Non SOR		Supply, Installation, Testing and commissioning of 7 way distribution feeder pillar with 2 Nos.. MCCB 4 pole, 3 ph, 415 V, 400A for incoming and 5 Nos. outgoing MCCB 4 pole, 415V, 3 phase, 100 A rating type, suitable for outdoor installation, in accordance with technical specification.	Nos.	31.00		
165	Non SOR		Supply, Installation, Testing and commissioning of 3 ph, 415V distribution service pillar for LT, 100A incoming, 2 Nos. 32A TPN, 10Nos. 16A SPN rating feeder type distribution service pillar suitable for outdoor installation, in accordance with technical specification.	Nos.	19.00		
166	Non SOR		Supply, installation, testing and commissioning of outdoor type Street Light Control Panel conform with IS: 2147. Floor / wall/ structure mounted, free standing, suitable for cable entry from bottom side, dust proof, vermin proof, 3 phase and neutral, bus bar aluminium, neutral bus shall be of same size as phase bus bars, Short circuit capacity for the bus bars and MCB shall be 10 kA with incomer of 32A FP MCB and outgoing of 6 Nos.16A FP MCB	Nos.	34.00		
			HT Electrical Cable				
167	DHBVN (Gurgaon)	1 A	Supply of 3C 400 mm ² 11 kV XLPE Armoured cable	Meter	35865.00		
168	DHBVN	32.4	Supply, Erection of 11kV XLPE cable 3C 95 sqmm	km	1.05		
			HT Cable Termination Kits				
169	DHBVN (Gurgaon)	3 d	Supply and erection of ID Termination kit for 11kV 3/C 400 mm ² cable	Nos.	276.00		
170	DHBVN (Gurgaon)	3 g	Supply and erection of OD Termination kit for 11kV 3/C 400 mm ² cable	Nos.	61.00		
171	DHBVN (Gurgaon)	3 a	Supply and erection of Straight Jointing kit for 3/C 400 mm ² 11 kV XLPE cable	Nos.	47.00		
172	DHBVN	37.2	Supply and erection of HT 11kV XLPE UG indoor Heat Shrinkable Termination Kit 3/C 120 mm ²	Nos.	6.00		
173	DHBVN	37.3	Supply and erection of HT 11kV XLPE UG indoor Heat Shrinkable Termination Kit 3/C 185 mm ²	Nos.	10.00		

Sno	Ref.	Nos..	Description of Item	Unit	Quantity	Rate (Rs)	Amount (Rs)
174	DHBVN	37.4	Supply and erection of HT 11kV XLPE UG indoor Heat Shrinkable Termination Kit 3/C 300 mm ²	Nos.	10.00		
175	DHBVN	38.2	Supply and erection of HT 11kV XLPE U/G indoor heat shrinkable termination kit 3C x 95 sqmm	Nos.	210.00		
176	DHBVN	37.1	Supply and erection of HT 11kV XLPE U/G outdoor heat shrinkable termination kit 3C x 95 sqmm	Nos.	46.00		
177	DHBVN	F 8 i	Making of HT cable joints	Nos.	561.0		
			HT cable laying				
178	Non SOR		Laying of one number PVC insulated and PVC sheathed / XLPE power cable of 11 kV grade of following size in the existing RCC/HUME/ METAL/HDPE pipe as required. Above 120 sq. mm and upto 400 sq. mm	Meter	30877.50		
179	Non SOR		Laying and fixing of following sizes one number power cable of 11 KV grade on surface/ existing cable tray as required. Size exceeding 185 sq. mm. but Nos.t exceeding 400 sq. mm	Meter	4892.50		
			Bill of Quantity Electrical works (Phase I Road) for LT works				
			LT Electrical Cable				
180	Non SOR		Supply of LT XLPE Armoured 3.5 core, 185 sqmm AL cable	Meter	26714.00		
181	Non SOR		Supply of LT XLPE Armoured 3.5 core, 50 sqmm AL cable	Meter	4738.00		
182	Non SOR		Supply of LT XLPE Armoured 3.5 core, 35 sqmm AL cable	Meter	4763.00		
183	Non SOR		Supply of LT XLPE Armoured 3.5 core, 25 sqmm AL cable	Meter	7321.00		
184	Non SOR		Supply of LT XLPE Armoured 4 core, 25 sqmm AL cable	Meter	8259.00		
185	Non SOR		Supply of LT XLPE Armoured 4 core, 16 sqmm AL cable	Meter	39258.00		
186	Non SOR		Supply of LT XLPE Armoured 2 core, 25 sqmm AL cable	Meter	6969.00		
187	Non SOR		Supply of LT XLPE Armoured 2 core, 16 sqmm AL cable	Meter	4845.00		
188	Non SOR		Supply of LT XLPE Armoured 2 core, 10 sqmm AL cable	Meter	4129.00		
189	DHBVN	33.1	Supplying and erection of Unarmoured copper control cable 2C X 4 sqmm	Km	2.00		
			LT Cable Termination Kits				
190	Non SOR		Supplying and making end termination with brass compression gland and aluminium lugs for following size of PVC insulated and PVC sheathed / XLPE aluminium conductor cable of 1.1 kV grade as required.-3½ X 185 sq. mm (57mm)	Each	2272.00		

Sno .	Ref.	Nos..	Description of Item	Unit	Quantity	Rate (Rs)	Amount (Rs)
191	Non SOR		Supplying and making outdoor end termination with cast resin compound including aluminium lugs and other jointing materials for following size of PVC insulated and PVC sheathed / XLPE aluminium conductor cable of 1.1 kV grade as required..-3½ X 185 sq. mm	Each	218.00		
192	Non SOR		Supplying and making end termination with brass compression gland and aluminium lugs for following size of PVC insulated and PVC sheathed / XLPE aluminium conductor cable of 1.1 kV grade as required.-3½ X 50 sq. mm (35 mm)	Each	374.00		
193	Non SOR		Supplying and making end termination with brass compression gland and aluminium lugs for following size of PVC insulated and PVC sheathed / XLPE aluminium conductor cable of 1.1 kV grade as required.-3½ X 35 sq. mm (32mm)	Each	388.00		
194	Non SOR		Supplying and making end termination with brass compression gland and aluminium lugs for following size of PVC insulated and PVC sheathed / XLPE aluminium conductor cable of 1.1 kV grade as required.-3½ X 25 sq. mm (28mm)	Each	570.00		
195	Non SOR		Supplying and making end termination with brass compression gland and aluminium lugs for following size of PVC insulated and PVC sheathed / XLPE aluminium conductor cable of 1.1 kV grade as required.-4 X 25 sq. mm (28mm)	Each	566.00		
196	Non SOR		Supplying and making end termination with brass compression gland and aluminium lugs for following size of PVC insulated and PVC sheathed / XLPE aluminium conductor cable of 1.1 kV grade as required.-4 X 16 sq. mm (28mm)	Each	3542.00		
197	Non SOR		Supplying and making end termination with brass compression gland and aluminium lugs for following size of PVC insulated and PVC sheathed / XLPE aluminium conductor cable of 1.1 kV grade as required.-3 X 25 sq. mm (19mm)	Each	610.00		

Sno	Ref.	Nos..	Description of Item	Unit	Quantity	Rate (Rs)	Amount (Rs)
198	Non SOR		Supplying and making end termination with brass compression gland and aluminium lugs for following size of PVC insulated and PVC sheathed / XLPE aluminium conductor cable of 1.1 kV grade as required.-3 X 16 sq. mm (22mm)	Each	474.00		
199	Non SOR		Supplying and making end termination with brass compression gland and aluminium lugs for following size of PVC insulated and PVC sheathed / XLPE aluminium conductor cable of 1.1 kV grade as required.-3 X 10 sq. mm (22mm)	Each	472.00		
200	DHBVN	F 8 ii	Making of LT joints	Each	9486.00		
			LT Electrical Cable				
201	Non SOR		Laying of one number PVC insulated and PVC sheathed / XLPE power cable of 11 kV grade of following size in the existing RCC/HUME/ METAL/HDPE pipe as required. Above 120 sq. mm and upto 400 sq. mm	Meter	58990.15		
202	Non SOR		Laying and fixing of following sizes one number power cable of 11 KV grade on surface/ existing cable tray as required. Size exceeding 185 sq. mm. but Nos.t exceeding 400 sq. mm	Meter	3440.75		
203	Non SOR		Supply of LT XLPE Armoured 3.5 core, 185 sqmm AL cable	Meter	20270.00		
204	Non SOR		Supply of LT XLPE Armoured 3.5 core, 50 sqmm AL cable	Meter	16553.85		
205	Non SOR		Supply of LT XLPE Armoured 3.5 core, 35 sqmm AL cable	Meter	1297.25		
206	Non SOR		Supply of LT XLPE Armoured 3.5 core, 25 sqmm AL cable	Meter	6444.00		
			H Pole				
207	DHBVN	1.2	Supplying of PCC Pole 11 Meter Long	Nos.	116.00		
208	DHBVN	A 6	Erection of HT concrete poles (11 Meter Long)	Each	116.00		
209	DHBVN	23 ii)	Muffing of 11 meter long PCC pole (1.8 m below the ground and 0.3 m above the ground)	per pole	116.00		
210	DHBVN	A 7	Erection of Earthing of HT poles with road	Nos.	116.00		
211	DHBVN	4.3	Supplying of Dead end fitting for 11kV Disc insulator 45kN (T&C type)	Nos.	174.00		
212	DHBVN	K 4.2	Erection of 11kV Disc insulator 45kN (T&C type)	Nos.	174.00		
213	DHBVN	4.11	Supplying of Disc fitting (T&C type)	Nos.	174.00		
214	DHBVN	K 4.10	Erection of Disc fitting (T&C type)	Nos.	174.00		
215	DHBVN	11.1	Supplying of Lightning Arrester(9 kV)	Nos.	174.00		
216	DHBVN	C 3	Erection of 11kV lightning arrester set	SET	174.00		

Sno	Ref.	Nos..	Description of Item	Unit	Quantity	Rate (Rs)	Amount (Rs)
217	DHBVN	5.4	Supplying of ACSR conductor 100 sqmm (Dog) insulated	Km	1.39		
218	DHBVN	D 1 iv	Stringing and sagging of conductor of single wire including jointing and binding with insulators at supports: ACSR conductor 100 sqmm	km	0.87		
219	DHBVN	12.1	Supplying of 11kV 400A GO switch complete with handle, pipe and supporting channel as per Nigam's technical specification. Relavant ISS and latest ammendments 11 Meter	Nos.	58.00		
220	DHBVN	J 3	Erection of GO switch complete in all respect	Each	58.00		
221	DHBVN	2.3	Supplying of MS Channel (X Arm) 100 X 50 X 6 mm2200 mm (for H pole) wt 21 kg	Nos.	174.00		
222	DHBVN	K 1.3	Erection of MS Channel (X Arm) 100 X 50 X 6 mm2200 mm(for H pole)	Nos.	174.00		
223	DHBVN	2.11	Supplying MS Angle 50X50X6 mm - 2200 mm (Belting for H pole) wt 9.90 kg	Nos.	58.00		
224	DHBVN	K 1.9	Erection of MS Angle 50X50X6 mm - 2200 mm (Belting for H pole)	Nos.	58.00		
225	DHBVN	3.1	Supplying of PG clamp for 30/50/80/100 mm2	Nos.	348.00		
226	DHBVN	K 3.1	Erection of PG clamp for 30/50/80/100 mm2	Nos.	348.00		
227	DHBVN	3.2	Supplying of Half clamps Wt. 1.47 kg	Nos.	1062.00		
228	DHBVN	K 3.2	Erection of Half clamps Wt. 1.47 kg	Nos.	1062.00		
229	DHBVN	6.1	Supplying of GI stray wire 7/8 SWG	MT	1.67		
230	DHBVN	6.3	Supplying of GI Barbed wire	MT	0.42		
231	DHBVN	A 1	Erection of stray set complete with barbed wire	One Nos..	116.00		
232	DHBVN	4.14	Supplying of Guy Insulator	Nos.	232.00		
233	DHBVN	K 4.13	Erection of Guy Insulator	Nos.	232.00		
			LT Pole				
234	DHBVN	1.1	Supplying of PCC Pole 9 Meter Long	Nos.	238.00		
235	DHBVN	B 5	Erection of PCC 9 Meter LT pole	Each	238.00		
236	DHBVN	B 5	Muffing of 9 mtr long PCC pole (1.5 mtr below the ground 0.3 mtr above the ground)	per pole	238.00		
237	DHBVN	B 4	Erection of Earthing of LT poles with rod	One Nos..	238.00		
238	DHBVN	4.13	Supply of LT Insulator	Nos.	952.00		
239	DHBVN	k 4.12	Erection of LT Insulator	Nos.	952.00		
240	DHBVN	G 2 X	Installation of 3 phase meters in Urban area	Nos.	219.00		
241	DHBVN	G 2 Xii	Installation of single phase meters in Urban area	Nos.	291.00		
242	DHBVN	22.4	Supply and Erection of Polycarbonate weather proof outdoor type meter cover boxes sizes 315*265*130mm for single phase meter along with zinc plated clamps as per Nigam's tech. specs	Nos.	146.00		

Sno	Ref.	Nos..	Description of Item	Unit	Quantity	Rate (Rs)	Amount (Rs)
243	DHBVN	22.5	Supply and Erection of Polycarbonate weather proof outdoor type meter cover boxes for Three phase meter sizes 445mm*345mm*170mm along with zinc plated clamps as per Nigam's tech. specs	Nos.	208.00		
			Cable trays				
244	Non SOR		supply, installation, testing and commissioning of 600mm (W) X 75mm (H) X 2 mm (Thk.) GI ladder tray with all require accessories like angles, screws etc to finish the job.	Meter	16600.00		
245	Non SOR		Supply and installation of Jointing coupler plate with all require accessories to finish the job	Nos.	11068.00		
			HDPE Pipes				
246	Non SOR		Supplying and laying of HDPE Pipes 125mm Dia	Meter	179910.00		
247	DHBVN	56.18	Supplying and laying of HDPE Pipes 160mm Dia	Meter	60820.00		
248	Non SOR		Supplying and laying of HDPE Pipes 63mm Dia	Meter	32906.25		
			Earthing Work				
249	Non SOR		Supplying and installation of maintenance free Earthing with all allied materials	Nos.	1638.00		
250	DHBVN	6.4	GI strip 25*6 mtr 9 mtr for earthing wt 10.80kg (TATA/SAIL make)	Nos.	3276.00		
251	DHBVN	A 8	Earth boarding	Feet	16380.00		
252	DHBVN	K 5.3	Erection of GI strip 25 X 6 mm, 9 Meter For earthing	Nos.	1638.00		
253	DHBVN	56.7	Danger Plate Enameled with clamp	Nos.	452.00		
254	DHBVN	K 23.4	Erection of Danger Plate Enameled with clamp	Nos.	452.00		
255	DHBVN	56.6	Phase plate for each phase set of 3 (for H pole)	Set	58.00		
256	DHBVN	K 23.3	Erection of Phase plate for each phase set of 3 (for H pole)	Set	58.00		
257	DHBVN	56.8	Number Plate with clamp	Nos.	452.00		
258	DHBVN	K 23.5	Erection of Number Plate Enameled with clamp	Nos.	452.00		
			Dismantling				
259	Non SOR		Dismantling of pole/ street light standard/ strut embedded in cement concrete foundation etc. as required.	Each	344.00		
260	DHBVN (Aspects)	2 a- A6	Dismantling of Existing material of HT/LT network along with Distribution transformer and allied material and transportation to Nigam store- HT concrete poles	Each	1654.00		

Sno	Ref.	Nos..	Description of Item	Unit	Quantity	Rate (Rs)	Amount (Rs)
261	DHBVN (Aspects)	2 a- C2	Dismantling of Existing material of HT/LT network along with Distribution transformer and allied material and transportation to Nigam store- 25 to 63 KVA T/F with pole mounted substation	Each	9.00		
262	DHBVN (Aspects)	2 a- C1	Dismantling of Existing material of HT/LT network along with Distribution transformer and allied material and transportation to Nigam store- 100 to 200 KVA T/F with pole mounted substation	Each	145.00		
263	DHBVN (Aspects)	2 a- C6	Dismantling of Existing material of HT/LT network along with Distribution transformer and allied material and transportation to Nigam store- Transformer on plinth from 200KVA to 500KVA 11/4 complete in all respect	Each	3.00		
264	DHBVN (Aspects)	2 a- D1 iv	Dismantling of Existing material of HT/LT network along with Distribution transformer and allied material and transportation to Nigam store- ACSR conductor (100 sqmm)	km	41.65		
265	DHBVN (Aspects)	2 a- D1 ii	Dismantling of Existing material of HT/LT network along with Distribution transformer and allied material and transportation to Nigam store- ACSR conductor (50 sqmm)	km	15.08		
266	DHBVN (Aspects)	2 a- D1 i	Dismantling of Existing material of HT/LT network along with Distribution transformer and allied material and transportation to Nigam store- ACSR conductor (30 sqmm)	km	7.20		
267	DHBVN (Aspects)	2 a- 12 i)	Dismantling of Fuse box -SMC with pole clamp 30inch*18inch*8inch	Each	157.00		
268	DHBVN (Aspects)	2 a- K 4.12	Dismantling of LT insulator	Each	465.00		
269	DHBVN (Aspects)	2 a- G2 x	Dismantling of 3 phase meters in Urban area	Each	220.00		
270	DHBVN (Aspects)	2 a- G2 Xii	Dismantling of single phase meters in Urban area	Each	277.00		
271	DHBVN (Aspects)	2 a- 5 Vi	Dismantling of Existing material of HT/LT network along with Distribution transformer and allied material and transportation to Nigam store-HT Arial Bunched Cable 3C X 150sqmm + 120mm ² .	100 Mtr	20.50		

Sno	Ref.	Nos..	Description of Item	Unit	Quantity	Rate (Rs)	Amount (Rs)
272	DHBVN (Aspects)	2 a- 5 Vii	Dismantling of Existing material of HT/LT network along with Distribution transformer and allied material and transportation to Nigam store-HT Arial Bunched Cable 3C X 185sqmm + 150mm2.	100 Mtr	9.80		
273	DHBVN (Aspects)	2 a- 5 Viii	Dismantling of Existing material of HT/LT network along with Distribution transformer and allied material and transportation to Nigam store-HT Arial Bunched Cable 3C X 185sqmm + 240mm2	100 Mtr	3.65		
			Civil work for Electrical worl & Duct				
274	HSR	6.8 (i)	EXCAVATIONFOR PIPELINES RUNNING UNDER RESSURE IN TRENCHES AND PITS, IN OPEN AREAS, WHERE DISPOSAL OF SURPLUS EARTH IS DONE ALONGWITH THE ALIGNMENT including trimming & dressing sides, leveling of beds of trenches to correct grade, cutting joint holes, cutting trees and bushes, etc., refilling consolidation and entering of refill, in 15 cm layers AND RESTORATION OF UNMETALLED OR UNPAVED SURFACE TO ITS ORIGINAL CONDITION, including the cost of dewatering of rain water, diversion of traffic, night signals, fixing caution boards, watching, fenching etc., and outside the town in ORDINARY SOIL :-upto 1.5 Meterss depth	Cum	30569.23		
275	HSR	6.8 (ii)	EXCAVATIONFOR PIPELINES RUNNING UNDER RESSURE IN TRENCHES AND PITS, IN OPEN AREAS, WHERE DISPOSAL OF SURPLUS EARTH IS DONE ALONGWITH THE ALIGNMENT including trimming & dressing sides, leveling of beds of trenches to correct grade, cutting joint holes, cutting trees and bushes, etc., refilling consolidation and entering of refill, in 15 cm layers AND RESTORATION OF UNMETALLED OR UNPAVED SURFACE TO ITS ORIGINAL CONDITION, including the cost of dewatering of rain water, diversion of traffic, night signals, fixing caution boards, watching, fenching etc., and outside the town in ORDINARY SOIL :-exceeding 1.5 Meterss depth, but upto 2.25 Meterss depth	Cum	10473.97		

Sno .	Ref.	Nos..	Description of Item	Unit	Quantity	Rate (Rs)	Amount (Rs)
276	HSR	6.8 (iii)	EXCAVATION FOR PIPELINES RUNNING UNDER PRESSURE IN TRENCHES AND PITS, IN OPEN AREAS, WHERE DISPOSAL OF SURPLUS EARTH IS DONE ALONG WITH THE ALIGNMENT including trimming & dressing sides, leveling of beds of trenches to correct grade, cutting joint holes, cutting trees and bushes, etc., refilling consolidation and entering of refill, in 15 cm layers AND RESTORATION OF UNMETALLED OR UNPAVED SURFACE TO ITS ORIGINAL CONDITION, including the cost of dewatering of rain water, diversion of traffic, night signals, fixing caution boards, watching, fencing etc., and outside the town in ORDINARY SOIL :-exceeding 2.25 Meters depth, but upto 3.00 Meters depth	Cum	6218.40		
277	HSR	10.64	Design mix cement concrete of grade M-15 with minimum cement contents 315 Kg./Cum in foundation and plinth.	Cum	930.99		
278	HSR	10.67	Design mix cement concrete of grade M-25 with minimum cement contents 405 Kg./cum in foundation and plinth.	Cum	1904.00		
279	HSR	10.68	Design mix cement concrete of grade M-30 with minimum cement contents 420 Kg./cum in foundation and plinth. -for Precast Slab	Cum	480.00		
280	HSR	9.5	Centring and shuttering for faces of walls, partitions, retaining walls, well steining and the like (vertical or battering) including attached pilasters etc.	Sqm	76200.24		
281	HSR	9.2	Centring and shuttering for flat surfaces such as suspended floors, roofs, landings, chhajjas, shelves etc. inclination Nos. t exceeding 25 degree with horizontal-Centring and shuttering for reinforced	Sqm	9008.04		
282	HSR	10.67	Design mix cement concrete of grade M-30 with minimum cement contents 420 Kg./cum in foundation and plinth.	Cum	1964.17		
283	HSR	18.22	Fe- 500 EQR TMT Steel bars RCC, works, where Not including in the complete rate of RCC including bending, binding and placing in position complete.	Quintal	5217.81		
284	Non SOR		Providing and fixing in position pre-cast R.C.C. manhole cover and frame of required shape and approved quality L D - 2.5 Rectangular shape 600x450 mm internal dimensions	each	100.00		

Sno .	Ref.	Nos..	Description of Item	Unit	Quantity	Rate (Rs)	Amount (Rs)
			Cable Bridge				
285	HSR	6.6	Earth work in excavation in foundations, trenches, etc.in all kinds of soils, Not exceeding 2 Meters depth including dressing of bottom and sides of trenches, stacking the excavated soil, clear from the edge of excavation and subsequent filling around masonry, in 15 cm layers with compaction, including disposal of all surplus soil, as directed within a lead of 30 Meters	cum	41955.76		
286	HSR	10.4	Cement Concrete 1:3:6 with stone aggregate 20mm Nominal size in foundation and plinth.	Cum	2.75		
287	HSR	10.32	Design mix cement concrete of grade M-15 with minimum cement contents 315 Kg./Cum in foundation and plinth.	Cum	100.92		
288	HSR	10.66	Design mix cement concrete of grade M-25 with minimum cement contents 405 Kg./cum in foundation and plinth.	Cum	230.57		
289	HSR	9.13	Shuttering for faces of concrete foundations and foundation beams (vertical or battering)	Sqm	7695.00		
290	HSR	18.7	Structural steel work in angles, tees and flats, welded including cutting fixing all gusset plates, bolts, nuts, welding rod, etc., with hoisting and erecting in position:-For roof trusses, well kerbs, plates and trussed girders, etc., of any span for buildings and bridges	Quintal	51.78		
291	HSR	16.1	Applying priming coat on steel work consisting of genuine red lead mixed with linseed oil and turpentine oil in equal proportions.	Sqm	320.00		
292	HSR	16.17	Painting two coats excluding priming coat with ready-mixed paint for metallic surfaces in all shades on new steel or iron work.	Sqm	320.00		
293	Non SOR		Providing and supplying aluminium extruded tubular and other aluminium sections as per the architectural drawings and approved shop drawings, the aluminium quality as per grade 6063 T5 or T6 as per BS 1474,including super durable powder coating of 60-80 microns conforming to AAMA 2604 of required colour and shade as approved by the Engineer-in-Charge. (The item includes cost of material such as cleats, sleeves, screws etc. necessary for fabrication of extruded aluminium frame work. Nothing extra shall be paid on this account).	Kg	995.33		

Sno .	Ref.	Nos..	Description of Item	Unit	Quantity	Rate (Rs)	Amount (Rs)
			PLINTH OF TRANSFORMER				
294	HSR	6.6	Earth work in excavation in foundations, trenches, etc.in all kinds of soils, Not exceeding 2 Meters depth including dressing of bottom and sides of trenches, stacking the excavated soil, clear from the edge of excavation and subsequent filling around masonry, in 15 cm layers with compaction, including disposal of all surplus soil, as directed within a lead of 30 Meters	Cum	1210.10		
295	HSR	10.64	Design mix cement concrete of grade M-15 with minimum cement contents 315 Kg./cum in foundation and plinth.	Cum	119.95		
296	HSR	11.4	First class brick laid in cement sand mortar 1:4 in foundation and plinth.	Cum	402.19		
297	HSR	15.7	12 mm thick cement plaster damp proof course 1:3 with 2 coats of bitumen at 1.65 kg per sqm laid hot and sanded.	Sqm	2646.00		
298	Non SOR		Supplying and filling in plinth with sand under floors, including watering, ramming, consolidating and dressing complete.	Cum	921.38		
299	HSR	10.65	Design mix cement concrete of grade M-20 with minimum cement contents 405 Kg./Cum in foundation and plinth.	Cum	61.43		
300	Non SOR		Providing and spreading of 20 mm aggregate near transfer plinth on the floors, including levelling, consolidating and dressing complete. Thickness as per drawing	Cum	588.00		
301	Non SOR		Providing chain link fencing 50mm size of 8 guage properly stretched between rectangular poles and fixed with suitable bolts & nuts, the free ends shall be welded to the pole and block pipe at top and bottom as required including cost of all materials, labour, lead and lifts and as per the directions of the Engineer-in-charge of work including two coats of approved quality paint over one coat of shop paint	Sqm	17173.80		
			POLE FOUNDATION				
302	HSR	6.6	Earth work in excavation in foundations, trenches, etc.in all kinds of soils, Not exceeding 2 Meters depth including dressing of bottom and sides of trenches, stacking the excavated soil, clear from the edge of excavation and subsequent filling around masonry, in 15 cm layers with compaction, including disposal of all surplus soil, as directed within a lead of 30 Meters -For POLE FOUNDATION	Cum	85.50		

Sno .	Ref.	Nos..	Description of Item	Unit	Quantity	Rate (Rs)	Amount (Rs)
303	HSR	10.64	Design mix cement concrete of grade M-15 with minimum cement contents 315 Kg./Cum in foundation and plinth. For POLE FOUNDATION	Cum	52.48		
304	Non SOR		Shuttering for faces of concrete foundations and foundation beams (vertical or battering- For POLE FOUNDATION	Sqm	87.48		
			Street & Landscape Lighting				
305	Non SOR		Designing, Supply, Install, Testing and commissioning of Single arm light pole with LED luminaires (IP 66) with 7 Nos. feeder pillars for proper distribution of power to lights along the road. Provision for dimming solution of each pole and controlled from Command Control Centre with LORA gateway. Pole should be made of GI of minimum 200 mm inner diameter at bottom and height of 7 Meter with powder coating minimum thickness of 50 μ of colour with toughened glass of thickness 12mm and fixing with a symbol as per Engineer -in-Charge. The shape of pole shall be tubular consisting of 200mm, 100mm, 75mm and 50mm or as per the drawings.	Nos.	307.00		
306	Non SOR		Designing, Supply, Install, Testing and commissioning of Single arm light pole with LED luminaires (IP 66) with 7 Nos. feeder pillars for proper distribution of power to lights along the road. Provision for dimming solution of each pole and controlled from Command Control Centre with LORA gateway. Pole should be made of GI of minimum 200 mm inner diameter at bottom and height of 9 Meter with powder coating minimum thickness of 50 μ of colour with toughened glass of thickness 12mm and fixing with a symbol as per Engineer -in-Charge. The shape of pole shall be tubular consisting of 200mm, 100mm, 75mm and 50mm or as per the drawings.	Nos.	60.00		
307	Non SOR		Designing, Supply, Install, Testing and commissioning of Single arm light pole with LED luminaires (IP 66) with 7 Nos. feeder pillars for proper distribution of power to lights along the road. Provision for dimming solution of each pole and controlled from Command Control Centre with LORA gateway. Pole should be made of GI of minimum 200 mm inner diameter at bottom and height of 6 Meter with powder coating minimum	Nos.	200.00		

Sno .	Ref.	Nos..	Description of Item	Unit	Quantity	Rat e (Rs)	Amoun t (Rs)
			thickness of 50 µ of colour with toughened glass of thickness 12mm and fixing with a symbol as per Engineer -in-Charge. The shape of pole shall be tubular consisting of 200mm, 100mm, 75mm and 50mm or as per the drawings.				
308	Non SOR		Designing, Supply, Install, Testing and commissioning of symmetrical double arm light pole with LED luminaire (IP 66) with 2 Nos. feeder pillars for proper distribution of power to lights along the road. Provision for dimming solution of each pole and controlled from Command Control Centre with LORA gateway. Pole shall be made of GI of minimum 150 mm inner diameter and height of 9 Meter with powder coating of colour with toughened glass of thickness 12mm as per Engineer -in-Charge. The shape of pole shall be tubular consisting of 200mm, 100mm, 75mm and 50mm or as per the drawings.	Nos.	144.00		
309	Non SOR		Designing, Supply, Install, Testing and commissioning of asymmetrical double arm light pole with LED luminaire (IP 66) with 2 Nos. feeder pillars for proper distribution of power to lights along the road. Provision for dimming solution of each pole and controlled from Command Control Centre with LORA gateway. Pole shall be made of GI of minimum 150 mm inner diameter and height of 9 Meter with powder coating of colour with toughened glass of thickness 12mm as per Engineer -in-Charge. The shape of pole shall be tubular consisting of 200mm, 100mm, 75mm and 50mm or as per the drawings.	Nos.	236.00		
310	Non SOR		Designing, Supply, Install, Testing and commissioning of Columnar light with LED luminaire (IP 65) with 1 Nos. feeder pillars for proper distribution of power to lights along the road. Pole shall be made of GI of minimum 150 mm inner diameter and height of 4.2 Meter with powder coating of colour with toughened glass of thickness 12mm as per Engineer -in-Charge. The shape of pole shall be tubular consisting of 100mm, 75mm and 50mm or as per the drawings.	Nos.	35.00		

Sno.	Ref.	Nos..	Description of Item	Unit	Quantity	Rate (Rs)	Amount (Rs)
311	Non SOR		Designing, Supply, Install, Testing and commissioning of double arm light pole with LED luminaire (IP 66) with 2 Nos. feeder pillars for proper distribution of power to lights along the road. Provision for dimming solution of each pole and controlled from Command Control Centre with LORA gateway. Pole shall be made of GI of minimum 150 mm inner diameter and height of 9 Meter with powder coating of colour with toughened glass of thickness 12mm as per Engineer -in-Charge. The shape of pole shall be tubular consisting of 200mm, 100mm, 75mm and 50mm or as per the drawings.	Nos.	133.00		
312	Non SOR		Designing, Supply, Install, Testing and commissioning of Columnar light with LED luminaire (IP 65) with 1 Nos. feeder pillars for proper distribution of power to lights along the road. Pole shall be made of GI of minimum 150 mm inner diameter and height of 4.2 Meter with powder coating of colour with toughened glass of thickness 12mm as per Engineer -in-Charge. The shape of pole shall be tubular consisting of 200mm, 100mm, 75mm and 50mm or as per the drawings.	Nos.	230.00		
313	Non SOR		Designing, Supply, Install, Testing and commissioning of single arm light pole with LED luminaire (IP 66) with 6 Nos. feeder pillars consist of IEC rated switchgears as require for proper distribution of power to lights along the road. Provision for dimming solution of each pole and controlled from Command Control Centre with LORA gateway. Pole shall be made of GI of minimum 200 mm inner diameter at bottom and height of 9 Meter with powder coating of colour as per Engineer -in-Charge. The shape of pole shall be as per the drawings.	Nos.	204.00		
314	Non SOR		Providing and fixing of drive over light. Luminaire made up of die-casting dark grey powder coated aluminium, corrosion resistance with low copper content. Hard chromeplated stainless steel 316 grade front ring. Silicone seal gasket. Stainless steel screws. Step tempered glass of 7mm thickness with static load resistance of ≥ 2000 kgs. Luminaire hard wired with 3 x 1.0mm ²	Nos.	95.00		

Sno.	Ref.	Nos..	Description of Item	Unit	Quantity	Rate (Rs)	Amount (Rs)
			cable of 0.5mts length. Supplied with mounting sleeve for preparing recessed opening in ground. Integral power supply. Earth connection. Safety class I. Protection class IP67 Mechanical resistance IK10. Conformity mark. Suitable for operation on 240V, 50Hz single phase ac supply. Dimension : 55 mm dia x 86 mm integrated with 3w LED and 2 way connector. Fixture Specifications to be approved by Consultant before Procurement.				
315	Non SOR		Providing and fixing of In ground luminaire with symmetrical beam angle of 20 degree.Luminaire made up of die-casting dark grey powder coated aluminium, corrosion resistance with low copper content. Hard chromeplated stainless steel 316 grade front ring. Silicone seal gasket. Stainless steel screws. Step tempered glass of 7mm thickness with static load resistance of 1704 kgs. Optical reactor efficiency $\geq 85\%$ Luminaire hard wired with 3 x 1.0mm ² cable of 0.5mts length. Supplied with mounting sleeve for preparing recessed opening in ground. Integral power supply. Earth connection. Safety class. Protection class IP67. Mechanical resistance IK08. Conformity mark. Suitable for operation on 240V, 50Hz single phase ac supply. Dimension 55mm dia x 80mm integrated with 3W LED and 2 way connector. Fixture Specifications to be approved by Consultant before Procurement.	Nos.	2000.00		
316	Non SOR		Supply of LED Linear Lighting giving homogeneous light output, made of combination of special plastic material resistant to saltwater and UV radiation and 316L grade of stainless steel having robust design with vandal resistance rating of IK10 and ingress protection rating of IP67, fixture should have wattage of 9.6W/mtr having color of LED in 3000K/4000K /Amber or as per consultant request, fixture should have dimensions width 18mm, height 35mm and length 1000mm, should have cable outlet at the back thus giving seamless, shadow-free illumination. Fixture to have high-quality LED 24VDC, With integrated driver electronics fixture to have service life > 50,000 h. Fixture's	Nos.	40.00		

Sno .	Ref.	Nos..	Description of Item	Unit	Quantity	Rate (Rs)	Amount (Rs)
			temperature range from - 25°C to + 50°C. Fixture's mounting clamp made of stainless steel 316L grade for mounting. Should be CE certified.				
317	Non SOR		<p>Providing and fixing of In ground luminaire with asymmetrical beam angle of 35 degree. Luminaire made up of die-casting grey powder coated aluminium, corrosion resistance with low copper content. Hard chromeplated stainless steel 316 grade front ring. Molding shaped seal gasket. Stainless steel screws. Step tempered glass of 10mm thickness with static load resistance. Optical rector efficiency = 90%</p> <ul style="list-style-type: none"> • Luminaire hard wired with 3 x 1.0mm² cable of 0.5mts length. Supplied with mounting sleeve for preparing recessed opening in ground. Integral power supply. Earth connection. Safety class I. Protection class IP67. Mechanical resistance IK09 & IK10. Conformity mark. Suitable for operation on 240V, 50Hz single phase ac supply. Dimension : 173 mm dia x 128mm integrated with 14 w LED 	Nos.	400.00		
			Land scaping and Street scape Civil works				
318	HSR	6.6	Earth work in excavation in foundations, trenches, etc.in all kinds of soils, Nos.t exceeding 2 Meters depth including dressing of bottom and sides of trenches, stacking the excavated soil, clear from the edge of excavation and subsequent filling around masonry, in 15 cm layers with compaction, including disposal of all surplus soil, as directed within a lead of 30 Meters	Cum	10778.68		
319	Non SOR		Providing and Construction of subgrade with approved materials from borrow areas as per Technical Specifications Clause 305 & 403 including all leads and lifts. Selected Earth (CBR Nos.t less than 8%)	Cum	9880.00		
320	Non SOR		Providing and laying Granular Sub Base (drainage layer) conforming to Grading V of Table 400.1 (MORT&H Rev 5th 2013 specification) of compacted thickness of 200 mm with specified graded stone metal and sand mixed in pugmill and laid with mechanical means spreading with motor grader and compacting with vibratory roller having	Cum	9432.85		

Sno .	Ref.	Nos..	Description of Item	Unit	Quantity	Rate (Rs)	Amount (Rs)
			minimum 80-100KN static weight to achieve desired density of 98% of MDD.				
			CONCRETE WORK				
321	HSR	10.64	Design mix cement concrete of grade M-15 with minimum cement contents 315 Kg./cum in foundation and plinth.	Cum	2260.79		
322	HSR	10.65	Design mix cement concrete of grade M-20 with minimum cement contents 410 Kg./cum in foundation and plinth.	Cum	71.28		
323	HSR	10.67	Design mix cement concrete of grade M-30 with minimum cement contents 420 Kg./cum in foundation and plinth.	Cum	24.81		
324	HSR	9.5	Centring and shuttering for faces of walls, partitions, retaining walls, well steining and the like (vertical or battering) including attached pilasters etc.	Sqm	1233.32		
325	HSR	18.22	Fe- 500 EQR TMT Steel bars RCC, works, where Not including in the complete rate of RCC including bending, binding and placing in position complete.	Quintal	20.84		
			BRICK WORK				
326	HSR	11.4	First class brick laid in cement sand mortar 1:4 in foundation and plinth.	Cum	5519.51		
327	HSR	11.9	First class brickwork laid in cement sand mortar 1:4 in first storey upto 4 meters above plinth level.	Cum	42.30		
328	HSR	11.51	11.43 cm thick brick wall with every fourth course reinforced with hoop-iron laid in 1:4 cement stone dust (from crusher) mortar in superstructure.	Sqm	350.00		
			PLASTERING				
329	HSR	15.7	12 mm thick cement plaster 1:6	Sqm	2892.96		
330	HSR	15.19	Pebbles dash exterior plaster on walls with a mixture of washed pebble or crushed stone graded from 6 mm to 12 mm Nominal size dashed over and including fresh cement plaster in 2 coats, first coat 10 mm thick cement plaster 1:4, (1 cement, 4 sand) and finishing coat 10 mm cement plaster 1:3, mixed with 10% finely ground hydrated lime by volume of cement including arises, chamfers and/or rounded angles Not exceeding 80 mm in grith.	Sqm	160.00		

Sno .	Ref.	Nos..	Description of Item	Unit	Quantity	Rate (Rs)	Amount (Rs)
			PAINTING				
331	HSR	16.24	Preparation of plastered or concrete surfaces for painting, including sand papering the surface, applying one coat of linseed oil and filling with approved quality filler, consisting of white lead, linseed oil, varnish and chalk mitti including finishing surface to the required finish, complete.	Sqm	2810.34		
332	HSR	16.25	Applying priming coat with cement primer in all shades on newly plastered or concrete exterior surfaces.	Sqm	2810.34		
333	HSR	16.26	Painting two coats with ready-mixed exterior paint in all shades on newly plastered or concrete surface of walls.	Sqm	2810.34		
334	HSR	16.9	Applying priming coat with metal primer on new steel or iron work including preparation of surface.	Sqm	5191.54		
335	HSR	16.17	Painting two coats excluding priming coat with ready-mixed paint for metallic surfaces in all shades on new steel or iron work.	Sqm	5339.24		
			FLOORING				
336	HSR	14.54(d)	Rough red sand stone (from Agra) 40 mm thick set in 12 mm thick cement coarse sand mortar in cement coarse sand mortar 1:3 including pointing with cement mortar 1:2 with an admixture of pigment to match the shade of stone	Sqm	8644.48		
337	HSR	14.55(d)	Fine dressed and rubbed red sand stone (from Agra) 40 mm thick, set in 12 mm thick cement coarse sand mortar -in cement coarse sand mortar 1:3 including pointing with cement mortar 1:2 with an admixture of pigment to match the shade of stone	Sqm	620.00		
338	HSR	14.62	Kota stone flooring 34 mm to 40 mm thick in any pattern as specified over 12 mm thick base of cement coarse sand mortar 1:3 laid and jointed with neat cement slurry mixed with pigment to match the shade of stone including rubbing and polishing.	Sqm	1420.00		
339	HSR	14.63	Kota stone rough dressed 40 mm to 50 mm thick slabs, set to pattern in pavements over 20 mm thick base of cement coarse sand mortar 1:3 laid and jointed with neat cement slurry mixed with pigment to match the shade of stone	Sqm	675.00		

Sno.	Ref.	Nos..	Description of Item	Unit	Quantity	Rate (Rs)	Amount (Rs)
340	Non SOR		Providing and laying gang saw cut 18 mm thick, mirror polished pre moulded and pre polished machine cut granite stone of required size and shape of approved shade, colour and texture in footpath, flooring cut granite stone of required size and shape of approved shade, colour and texture in footpath, flooring in road side plazas and similar locations, laid over 20mm thick base of cement mortar 1:4 (1cement : 4 coarse sand) including grouting the joints with white cement mixed with matching pigment, epoxy touch ups etc. complete as per direction of Engineer-in-Charge.	Sqm	6953.80		
341	Non SOR		Providing and fixing 10x10x7.50 cm Granite stone block hand cut and chisel dressed on top, for paving in floors, drains etc. laid over 20mm thick base mortar 1:4 (1cement:4 coarse sand) with joints 10mm wide filled with same mortar including ruled pointing etc. complete as per direction of engineer-in charge.	Sqm	5200.00		
342	Non SOR		Providing and fixing 15x15x90 cm boundary stone of hard stone with top 30cm chisel dressed on all four sides including top (cost of excavation,refilling and concrete etc. to be paid for separately). Item for Bollard Stone	Each	983.33		
			INTERLOCKING BLOCKS				
343	HSR	10.158	Providing and laying 60mm thick interlocking paver blocks of all shapes and colours in design mix cement M-35 over a bed of 25mm thick fine sand complete in all respect.	Sqm	700.00		
344	Non SOR		Providing and laying tactile tile (for vision impaired persons as per standards) of size 300x300x9.8mm having with water absorption less than 0.5% and conforming to IS: 15622 of approved make in all colours and shades in for outdoor floors such as footpath, court yard, multi modals location etc., laid on 20mm thick base of cement mortar 1:4 (1cement : 4 coarse sand) in all shapes & patterns including grouting the joints with white cement mixed with matching pigments etc. complete as per direction of Engineer-in-Charge.	Sqm	6376.50		
345	Non SOR		Providing and laying Saucer Drain 300x300x100 mm	Meter	17560.00		

Sno .	Ref.	Nos..	Description of Item	Unit	Quantity	Rate (Rs)	Amount (Rs)
346	Non SOR		Providing and laying of Tree grate surround consists of 4 Nos. panels of each tree Overall dimensions 1500mmx1500mmx40/100mm(thickness , • Manufactured with M-30 grade of concrete using vibro-compaction process using jointless FRP moulds so as to achieve shuttering finish on five faces and gurmala finish on the top surface.choice of standard colors and unlimited custom colors will match any natural stone finish or interlock pavers in the surrounding,top surface of the tree grates can also be polished on request.	Each	3722.38		
347	Non SOR		Providing and laying factory made chamfered edge 80 mm thick Cement Concrete paver blocks In foot path, park & lawns driveway or light & traffic parking etc. of required strength, thickness & size/ shape, made bytable vibratory method using PU mould, laid in required colour & pattern over 50mm thick compacted bed of course sand, compacting and proper embedding/laying of inter locking paver blocks into the sand bedding layer through vibratory compaction by using plate vibrator, filling the joints with sand and cutting of paver blocks as per required size and pattern, finishing and sweeping extra sand, allcomplete as per manufacturer's specifications & direction of Engineer in-Charge.	SQM	17080.00		
			CLADDING				
348	HSR	14.59	Fine dressed and machine rubbed red sand stone (from Agra) 25 mm to 30 mm thick on wall facing (lining) on wall, pillars, skirting, dado and riser of step laid in any pattern as specified on 12 mm thick cement coarse sand mortar 1:3 with neat cement with an admixture of pigment to match the shade of stone including labour for fixing cramps, dowels and pins etc.	Sqm	1966.23		
349	HSR	14.66	Kota stone 20 mm thick in skirting risers of steps, dados and wall facing (lining) and pillars laid on 12 mm thick cement coarse sand plaster 1:3 laid and jointed with neat cement slurry, mixed with pigment to match the shade of stone including rubbing and polishing including labour for fixing cramps, dowels and pins etc.	Sqm	160.00		

Sno.	Ref.	Nos..	Description of Item	Unit	Quantity	Rate (Rs)	Amount (Rs)
350	Non SOR		Providing and fixing dry cladding upto 10 Meter heights with 30 mm thick gang saw cut Granite stone with (machine cut edges) of uniform colour and size upto 1mx1m, fixed to structural steel frame work and/ or with the help of cramps, pins etc. and sealing the joints with approved weather sealant as per Architectural drawing and direction of Engineer-in-charge.(The steel frame work, stainless steel cramps and pins etc. shall be paid for separately).	Sqm	42.44		
351	Non SOR		Providing and fixing adjustable stainless steel cramps of approved quality,required shape and size, adjustable with stainless steel nuts, bolts and washer (total weight Nos.t less than 260 gms), for dry stone cladding fixed on frame work at suitable location, including making necessary recesses in stone slab, drilling required holes etc complete as per direction of the Engineer-in-charge.	Each	150.00		
352	Non SOR		Providing and Fixing Stainless Steel Box of Grade SS304 of Approximate Size 1800 X1800 X450mm with laser/ CNC cutting of Approved Design as directed by the Engineer-in- Charge.	Nos.	20.00		
			COPING				
353	HSR	14.55(d)	Fine dressed and rubbed red sand stone (from Agra) 40 mm thick, set in 12 mm thick cement coarse sand mortar -in cement coarse sand mortar 1:3 including pointing with cement mortar 1:2 with an admixture of pigment to match the shade of stone	Sqm	855.89		
354	HSR	14.58	Extra for Nosing in steps and treads of red fine dressed sand stone. (for Coping)	Meter	120.59		
355	HSR	14.62	Kota stone flooring 34 mm to 40 mm thick in any pattern as specified over 12 mm thick base of cement coarse sand mortar 1:3 laid and jointed with neat cement slurry mixed with pigment to match the shade of stone including rubbing and polishing.	Sqm	80.00		
356	Non SOR		Providing and fixing 18mm thick gang saw cut mirror polished premoulded and prepolished, machine cut for kitchen platforms, vanity counters, window sills , facias and similar locations of required size, approved shade, colour and texture laid over 20mm thick base cement	Sqm	136.08		

Sno .	Ref.	Nos..	Description of Item	Unit	Quantity	Rat e (Rs)	Amoun t (Rs)
			mortar 1:4 (1 cement : 4 coarse sand) joints treated with white cement, mixed with matching pigment, epoxy touch ups, including rubbing, curing, moulding and polishing to edges to give high gloss finish etc. complete at all levels.- Area of slab over 0.50 sqm. - Granite of any colour & shade on Stone Benches				
357	Non SOR		Concrete Bollards- Provision of bollards at minor junctions, plot entry points and pedestrian crossing with a min spacing of 1.2m c/c or as directed by Engineer In-charge. Providing and fixing of Concrete Bollards of M-30 grade and size 1000 mm (ht) x 250mm (dia), purchased from SMC's approved vendor, manufactured of reinforced concrete by vibro compaction method using FRP/ steel moulds as per the direction of Engineer in charge, complete incl. all consumables , Tand P and Labours required for the job	Nos.	4818.87		
358	Non SOR		Precast Concrete Reinforced Trash Bin. The Bin consists of grey cement color of thickness, manufactured by using M-40 Grade of Concrete & reinforced suitable to prevent damage during handling, transportation, erection & long use. Bin stands on one upright and has a bottom opening MS hatch that allows garabge to be emptied from it underside. rate includes cartage and fixing with foundation. Colour painted - varies per road- Trash Bin	Each	1195.64		
			STAINLESS STEEL WORK				
359	Non SOR		Providing and fixing as per drawing /image STAINLESS STEEL DUSTBIN SERIES : ,600MM DIA X900MM HEIGHT with post hight-1200 and pipe dia 40mm SS-Grade-304 (2 NOS. FORM A ONE SET) with provision of opening at the bottom of the bin.	ONE SET	28.00		
			MILD STEEL WORK				
360	Non SOR		Suplying and placing in position 116 mm dia, 900 mm high of Stainless Steel Bollard 150x6mm M.S. plate welded at bottom and embedded 150 mm in cement concrete 1:3:6 (1 Cement : 3 coarse sand : 6 graded stone aggregate 20 mm Nominal size), including necessary excavation of size 250 x 250 x 450 mm deep for the same in bitumen/concrete pavement at specified spacing.	Nos.	100.00		

Sno .	Ref.	Nos..	Description of Item	Unit	Quantity	Rat e (Rs)	Amoun t (Rs)
361	Non SOR		Steel work welded in built up sections/ framed work, including cutting,hoisting, fixing in position and applying a priming coat of approved steelprimer using structural steel etc. as required.In gratings, frames, guard bar, ladder, railings, brackets, gates and similar works as directed by Engineer-in-charge. -For Seating Bench weight-75 kg(image attached)	Kg	10500.00		
362	Non SOR		Steel work welded in built up sections/ framed work, including cutting,hoisting, fixing in position and applying a priming coat of approved steelprimer using structural steel etc. as required.In gratings, frames, guard bar, ladder, railings, brackets, gates and similar works as directed by Engineer-in-charge. For Tree Guard weight-50 kg(image attached)	Kg	10000.00		
363	Non SOR		Steel work welded in built up sections/ framed work, including cutting,hoisting, fixing in position and applying a priming coat of approved steelprimer using structural steel etc. as required.In gratings, frames, guard bar, ladder, railings, brackets, gates and similar works as directed by Engineer-in-charge. For Railing weight-20 kg/meter (image attached)	Kg	188000.00		
364	Non SOR		Designing, Supply and fixing of Steel work welded in built up sections/ framed work, including cutting,hoisting, fixing in position and applying a priming coat of approved steelprimer using structural steel etc. as required.In gratings, frames, guard bar, ladder, railings, brackets, gates and similar works as directed by Engineer-in-charge. For Tree Guard weight-15 kg	Each	3543.00		
365	Non SOR		Designing, Supply and fixing of Steel work welded in built up sections/ framed work, including cutting,hoisting, fixing in position and applying a priming coat of approved steelprimer using structural steel etc. as required.In gratings, frames, guard bar, ladder, railings, brackets, gates and similar works as directed by Engineer-in-charge. For Railing weight-30 kg/meter (image attached)	Kg	84348.00		

Sno	Ref.	Nos..	Description of Item	Unit	Quantity	Rate (Rs)	Amount (Rs)
			BENCHES				
366	Non SOR		Precast Concrete Reinforced Bench. The Bench consists of grey cement color of thickness - 100mm, back light - 1000mm & front height - 450mm, base width - 620mm, manufactured by using M-40 Grade of Concrete & reinforced suitable to prevent damage during handling, transportation, erection & long use.	Nos.	120.00		
367	Non SOR		Precast Concrete Reinforced straight bench with back of size - 60"x24", front height-18" and thickness-4", Colour- red, manufactured by using M-40 Grade of Concrete & reinforced suitable to prevent damage during handling, transportation, erection & long use. All parts are joined together with galvanized nuts & bolts of suitable size.		42.00		
368	Non SOR		Precast Concrete Reinforced straight bench without back of size - 66"x18" and weight 140 kg,Color- white , manufactured by using M-40 Grade of Concrete & reinforced suitable to prevent damage during handling,transportation, erection & long use.	Nos.	75.60		
369	Non SOR		Precast Concrete Reinforced straight bench with back of size - 18"x32"x48" and weight 215 kg,Color- yellow, manufactured by using M-40 Grade of Concrete & reinforced suitable to prevent damage during handling, transportation, erection & long use. All parts are joined together with galvanized nuts & bolts of suitable size.	Nos.	92.00		
370	Non SOR		Precast Concrete Reinforced straight bench without back of size - 60"x18"x18" ,Color- wood brown with white legs, manufactured by using M-40 Grade of Concrete & reinforced suitable to prevent damage during handling,transportation, erection & long use.	Nos.	44.00		
371	Non SOR		Precast Concrete Reinforced straight bench with back of Size - 72"x16" and 18" high ,Color- grey, manufactured by using M-40 Grade of Concrete & reinforced suitable to prevent damage during handling,transportation, erection & long use. All parts are joined together with galvanized nuts & bolts of suitable size.	Nos.	149.40		

Sno.	Ref.	Nos..	Description of Item	Unit	Quantity	Rate (Rs)	Amount (Rs)
372	Non SOR		Precast Concrete Reinforced Bench-Dimensions: Sitting Platform size - 2825mm length X 400 mm width X 50mm Thickness; Leg size - 400mm Height X 400mm Width X 80/55mm thickness; Sitting height is 450 mm.Sitting Platform is in Red colour while the legs are in grey colour.Manufactured by using M-30 grade of Concrete.Suitably reinforced to promote long use and to prevent damage during handling, transportation & erection.Treated with special anti-corrosive, water proof coating so as to make the surface glossy and water proof	Nos.	44.80		
373	Non SOR		Precast Concrete Reinforced straight bench without back of size - 60"x18"x18" ,Color- white, manufactured by using M-40 Grade of Concrete & reinforced suitable to prevent damage during handling,transportation, erection & long use.	Nos.	128.00		
374	Non SOR		Precast Concrete Reinforced Bench around pillars with size:1200 mm X 1000 mm X 50 mm Reinforced suitably to promote long use to (Thickness) height: 450mm.Prevent damage during handling. Manufactured by using an M-30 grade of transportation erection long use. Bench top is treated with a special anti-corrosive waterproof coating as to make surfaces glossy or terrazzo finish.	Nos.	32.00		
375	Non SOR		Precast Concrete Reinforced straight bench without back of size - 66"x18", height-18", thickness-4" and weight 140 kg, Color- red ,with 3 Nos.'s of reinforced concrete planks in red color of size 66" X 6"mm X 4",manufactured by using M-40 Grade of Concrete & reinforced suitable to prevent damage during handling, transportation, erection & long use. All parts are joined together with galvanized nuts & bolts of suitable size.	Nos.	28.00		
376	Non SOR		Precast Concrete Reinforced curved bench without back of size - 60"x18"x18" ,Color- grey, manufactured by using M-40 Grade of Concrete & reinforced suitable to prevent damage during handling ,transportation, erection & long use.	Nos.	120.00		

Sno .	Ref.	Nos..	Description of Item	Unit	Quantity	Rate (Rs)	Amount (Rs)
			WOOD WORK				
377	Non SOR		Providing and fixing WPC cladding (1800 X 135 X 22) mm covering over steel frame Work of aluminium tube of Size 2" X 1" with clip system , complete with necessary fixing arrangement and screws etc. complete as per approved design and as directed by the Engineer-in- charge.	Sqm	229.50		
			HORTICULTURE				
378	HSR	33.7	Fine dressing the ground	Sqm	66143.94		
379	Non SOR		Uprooting rank vegetation and weeds by digging the area to a depth of 300mm removing all weeds and other growth with roots by forking repeatedly, breaking clods, rough dressing, flooding with water, uprooting fresh growths after 10 to 15 days and then dressing, including disposal of all rubbish with all leads and lifts.	Sqm	73508.20		
380	Non SOR		Supply & mixing FYM - Cow dung manure -- 50 kg/ tree	Nos.	3756.00		
381	Non SOR		Supply & mixing Vermicompost @10kg/1cum	Nos.	4410.49		
382	Non SOR		Supply & mixing Neemkhali @4kg/1cum	Nos.	176.42		
383	Non SOR		Supply & mixing Gypsum @ 10kg/sqm of site prep. Area	Nos.	14701.64		
			GRASS				
384	HSR	33.9	Mixing earth and sludge or farm yard manure in proportion specified or as directed.	Cum	2047.06		
385	HSR	33.8	Spreading of sludge, farm-yard manure or/and good earth in required thickness (Cost of sludge, farm-yard manure or /and good earth to be paid for separately) (MIN 200 MM LAYER)	Cum	2047.06		
386	Non SOR		Providing and laying Neelgiri/Mexican grass turf with earth 50mm to 60mm Thickness of existing ground prepared with proper level and ramming with tools wooden (Dhurmos) and then rolling the surface with light roller make the surface smoothen and light watering with sprinkler and maintenance for 30 days or more till the grass establish properly, as per direction of Officer-in-charge	Sqm	4200.00		

Sno .	Ref.	Nos..	Description of Item	Unit	Quantity	Rate (Rs)	Amount (Rs)
387	Non SOR		Providing & laying Selection Nos.. 1 grass turf with earth 50mm to 60mm thickness on existing ground prepared with proper level and ramming with required tools wooden and than rolling the surface with light roller make the surface smoothen and light watering the same, as per direction of Officer-in-charge.	Sqm	10050.00		
388	Non SOR		Supply & Install Pusa Selection - 1 Specification for Lawn trenching in ordinary soil upto a depth of 30 cms. Inc. removal & stacking of serviceable materialsRough dressing the trenched ground up-rooting weeds & flooding.Supply & Stacking of good earth & manure mixing & spreading as specified or directed,Fine dressing the ground.Grassing with specified grass inc. watering untill establishment of the lawn.Grassing with specified grass inc. watering untill establishment of the lawn. Final levelling by spreading sand & good earth mixture, manure as & when required..	Sqm	16828.00		
			TREES/PALMS				
389	HSR	33.9	Mixing earth and sludge or farm yard manure in proportion specified or as directed.	Cum	910.36		
390	HSR	33.21(i)	Digging holes in all kinds of soil, and refilling the same, with the excavated earth, mixed with well decayed farm-yard manure (cost of well decayed farm yard manure to be paid separately)- in the ratio of 2:1 by volume (2 parts of stacked volume of earth after reduction by 20% : 1part of stacked volume of manure after reduction by 8%) flooding with water, dressing including removal of rubbish and surplus earth, if any with all leads and liftsHoles 1.2 m dia and 1.2 m deep.(TALL PALMS, TALL , ACCENT AND MEDIUM TREES)	Nos.	6257.00		

Sno .	Ref.	Nos..	Description of Item	Unit	Quantity	Rate (Rs)	Amount (Rs)
391	HSR	33.21(ii)	Digging holes in all kinds of soil, and refilling the same, with the excavated earth, mixed with well decayed farm-yard manure (cost of well decayed farm yard manure to be paid separately)- in the ratio of 2:1 by volume (2 parts of stacked volume of earth after reduction by 20% : 1part of stacked volume of manure after reduction by 8%) flooding with water, dressing including removal of rubbish and surplus earth, if any with all leads and lifts Holes 60 cm dia, and 60 cm deep.	Nos.	53764.00		
392	Non SOR		Providing Circular Cement Concrete pots of specified size, cast with cement concrete of Nominal mix 1:2:4 (1 cement: 2 coarse sand: 4 graded stone aggregate 6 mm Nominal size), reinforced with 7 Nos. (3 Nos horizontal & 4 Nos. vertical “ U “ shape) M.S. wires of 3.5 mm dia as per design, including required form work, finishing with cement punning on exposed surface, curing for specified period and stacking in required rows & height, all complete as per direction of engineer-in-charge -- Top inside dia 35 cm, outer bottom dia 25 cm, total height 35 cm with wall thickness of 25.4 mm	Nos.	100.00		
393	Non SOR		Filling of the following size empty pots with mixture of good earth & manure in the ratio of 2:1 (Two part of Good earth & one port of manure) and placing them on appropriate place i/c carriage of earth, manure and pots up to 50 mtr, as per direction of engineer incharge. (The cost of good earth, earthen pots & manure will be paid separately.) Size of Empty Pots 35cm Top dia, 25cm Bottom Dia & 35cm Perpendicular height	Nos.	100.00		
			TREES/ PALMS				
394	Non SOR		Supply & Install Trees/ Palms inclusive of: i).Removal of rubbish/ all construction debris /site trash, and surplus earth inclusive with all leads and lift. ii). Treat the pit with Chloropyriphos solution of 0.5% concentration(5 ml/liter water) as required iv). Flooding the pit with water after making kiaries where required vi). Fertilise the pit by adding DAP 50gm, MOP 25 gm, 50gm neem oil cake and 50 gm stearamel per pit at the time of planting.- ARECA PALM-	Nos.	100.00		

Sno	Ref.	Nos..	Description of Item	Unit	Quantity	Rate (Rs)	Amount (Rs)
			SUPARI ,2.5.0M TO 3.M HT, Minimum 5 canes per palm				
395	Non SOR		Supply & Install Trees/ Palms inclusive of: i).Removal of rubbish/ all construction debris /site trash, and surplus earth inclusive with all leads and lift. ii). Treat the pit with Chloropyriphos solution of 0.5% concentration(5 ml/liter water) as required iv). Flooding the pit with water after making kiaries where required vi). Fertilise the pit by adding DAP 50gm, MOP 25 gm, 50gm neem oil cake and 50 gm stearammeal per pit at the time of planting. JACARANDA MIMOSIFOLIA Minimum 3.0/3.5m overall height,Minimum 20-30mm caliper,Multibranching at 2.0m from collar.	Nos.	76.00		
396	Non SOR		Supply & Install Trees/ Palms inclusive of: i).Removal of rubbish/ all construction debris /site trash, and surplus earth inclusive with all leads and lift. ii). Treat the pit with Chloropyriphos solution of 0.5% concentration(5 ml/liter water) as required iv). Flooding the pit with water after making kiaries where required vi). Fertilise the pit by adding DAP 50gm, MOP 25 gm, 50gm neem oil cake and 50 gm stearammeal per pit at the time of planting- BAHUNIA PURPUREA , Minimum 2.4M -3.0M STEM height,Minimum 30/ 40 mm caliper.	Nos.	220.00		
397	Non SOR		Supply & Install Trees/ Palms inclusive of: i).Removal of rubbish/ all construction debris /site trash, and surplus earth inclusive with all leads and lift. ii). Treat the pit with Chloropyriphos solution of 0.5% concentration(5 ml/liter water) as required iv). Flooding the pit with water after making kiaries where required vi). Fertilise the pit by adding DAP 50gm, MOP 25 gm, 50gm neem oil cake and 50 gm stearammeal per pit at the time of planting- BAHUNIA PURPUREA , Minimum 2.4M -3.0M STEM height,Minimum 30/ 40 mm caliper.	Nos.	240.00		
398	Non SOR		Supply & Install Trees/ Palms inclusive of: i).Removal of rubbish/ all construction debris /site trash, and surplus earth inclusive with all leads and lift. ii). Treat the pit with	Nos.	700.00		

Sno	Ref.	Nos..	Description of Item	Unit	Quantity	Rate (Rs)	Amount (Rs)
			Chloropyriphos solution of 0.5% concentration(5 ml/liter water) as required iv). Flooding the pit with water after making kiaries where required vi). Fertilise the pit by adding DAP 50gm, MOP 25 gm, 50gm neem oil cake and 50 gm stearammeal per pit at the time of planting- TERMINALIA ARJUNA ,Minimum 3.0/3.5m overall height,Minimum 100mm caliper,Multibranching at 40/50mm caliper				
399	Non SOR		Supply & Install Trees/ Palms inclusive of: i).Removal of rubbish/ all construction debris /site trash, and surplus earth inclusive with all leads and lift. ii). Treat the pit with Chloropyriphos solution of 0.5% concentration(5 ml/liter water) as required iv). Flooding the pit with water after making kiaries where required vi). Fertilise the pit by adding DAP 50gm, MOP 25 gm, 50gm neem oil cake and 50 gm stearammeal per pit at the time of planting- MIMOSOPS ELENGI ,Minimum 2.0/2.5m overall height,Minimum 40/50mm caliper,Multibranching at 2.0m from collar	Nos.	125.00		
400	Non SOR		Supply & Install Trees/ Palms inclusive of: i).Removal of rubbish/ all construction debris /site trash, and surplus earth inclusive with all leads and lift. ii). Treat the pit with Chloropyriphos solution of 0.5% concentration(5 ml/liter water) as required iv). Flooding the pit with water after making kiaries where required vi). Fertilise the pit by adding DAP 50gm, MOP 25 gm, 50gm neem oil cake and 50 gm stearammeal per pit at the time of planting- LAGESTROEMIA SPECIOSA ,Minimum 2.0/2.5m overall height,Minimum 40/50mm caliper,Multibranching at 2.0m from collar.	Nos.	339.00		
401	Non SOR		Supply & Install Trees/ Palms inclusive of: i).Removal of rubbish/ all construction debris /site trash, and surplus earth inclusive with all leads and lift. ii). Treat the pit with Chloropyriphos solution of 0.5% concentration(5 ml/liter water) as required iv). Flooding the pit with water	Nos.	215.00		

Sno .	Ref.	Nos..	Description of Item	Unit	Quantity	Rat e (Rs)	Amoun t (Rs)
			after making kiaries where required vi). Fertilise the pit by adding DAP 50gm, MOP 25 gm, 50gm neem oil cake and 50 gm stearammeal per pit at the time of planting- ANTHOCEPHALUS KADAMB Minimum 3.0/2.5m overall height, 40-50MM CALIPER, Multibranching at 2.5m from collar				
402	Non SOR		Supply & Install Trees/ Palms inclusive of: i).Removal of rubbish/ all construction debris /site trash, and surplus earth inclusive with all leads and lift. ii). Treat the pit with Chloropyriphos solution of 0.5% concentration(5 ml/liter water) as required iv). Flooding the pit with water after making kiaries where required vi). Fertilise the pit by adding DAP 50gm, MOP 25 gm, 50gm neem oil cake and 50 gm stearammeal per pit at the time of planting- ANTHOCEPHALUS KADAMB Minimum 3.0/3.5m overall height, 100MM CALIPER, Multibranching at 2.5m from collar	Nos.	141		
403	Non SOR		Supply & Install Trees/ Palms inclusive of: i).Removal of rubbish/ all construction debris /site trash, and surplus earth inclusive with all leads and lift. ii). Treat the pit with Chloropyriphos solution of 0.5% concentration(5 ml/liter water) as required iv). Flooding the pit with water after making kiaries where required vi). Fertilise the pit by adding DAP 50gm, MOP 25 gm, 50gm neem oil cake and 50 gm stearammeal per pit at the time of planting- KUSUM (Schleichera trijuga) , Minimum 3.0/3.5m overall height,Minimum 40-50mm caliper,Multibranching at 2.0m from collar	Nos.	125.00		
404	Non SOR		Supply & Install Trees/ Palms inclusive of: i).Removal of rubbish/ all construction debris /site trash, and surplus earth inclusive with all leads and lift. ii). Treat the pit with Chloropyriphos solution of 0.5% concentration(5 ml/liter water) as required iv). Flooding the pit with water after making kiaries where required vi). Fertilise the pit by adding DAP 50gm, MOP 25 gm, 50gm neem oil cake and 50 gm stearammeal per pit at the time of planting- PLUMERIA PIXIE ,Minimum	Nos.	47.00		

Sno .	Ref.	Nos..	Description of Item	Unit	Quantity	Rat e (Rs)	Amoun t (Rs)
			3.0/3.5m overall height,Minimum 40-50mm caliper, Multibranching at 2.0m from collar				
405	Non SOR		Supply & Install Trees/ Palms inclusive of: i).Removal of rubbish/ all construction debris /site trash, and surplus earth inclusive with all leads and lift. ii). Treat the pit with Chloropyriphos solution of 0.5% concentration(5 ml/liter water) as required iv). Flooding the pit with water after making kiaries where required vi). Fertilise the pit by adding DAP 50gm, MOP 25 gm, 50gm neem oil cake and 50 gm stearammeal per pit at the time of planting- CHORISIA SPECICOSA ,Minimum 3.0/3.5m overall height,Minimum 40-50mm caliper,Multibranching at 2.0m from collar	Nos.	184.00		
406	Non SOR		Supply & Install Trees/ Palms inclusive of: i).Removal of rubbish/ all construction debris /site trash, and surplus earth inclusive with all leads and lift. ii). Treat the pit with Chloropyriphos solution of 0.5% concentration(5 ml/liter water) as required iv). Flooding the pit with water after making kiaries where required vi). Fertilise the pit by adding DAP 50gm, MOP 25 gm, 50gm neem oil cake and 50 gm stearammeal per pit at the time of planting- TABEBUIA ARGENTIA ,Minimum 3.0/3.5m overall height,Minimum 40-50mm caliper, Multibranching at 2.0m from collar	Nos.	168.50		
407	Non SOR		Supply & Install Trees/ Palms inclusive of: i).Removal of rubbish/ all construction debris /site trash, and surplus earth inclusive with all leads and lift. ii). Treat the pit with Chloropyriphos solution of 0.5% concentration(5 ml/liter water) as required iv). Flooding the pit with water after making kiaries where required vi). Fertilise the pit by adding DAP 50gm, MOP 25 gm, 50gm neem oil cake and 50 gm stearammeal per pit at the time of planting- TAMARINDUS INDICA(IMLI) , Minimum 3.0M STEM height,Minimum 100 mm caliper.	Nos.	190.00		

Sno .	Ref.	Nos..	Description of Item	Unit	Quantity	Rate (Rs)	Amount (Rs)
408	Non SOR		Supply & Install Trees/ Palms inclusive of: i).Removal of rubbish/ all construction debris /site trash, and surplus earth inclusive with all leads and lift. ii). Treat the pit with Chloropyriphos solution of 0.5% concentration(5 ml/liter water) as required iv). Flooding the pit with water after making kiaries where required vi). Fertilise the pit by adding DAP 50gm, MOP 25 gm, 50gm neem oil cake and 50 gm stearammeal per pit at the time of planting- AZARDICTA INDICA ,Minimum 2.0/2.5m overall height,Minimum 40-50mm caliper,Multibranching at 2.0m from collar	Nos.	10.00		
409	Non SOR		Supply & Install Trees/ Palms inclusive of: i).Removal of rubbish/ all construction debris /site trash, and surplus earth inclusive with all leads and lift. ii). Treat the pit with Chloropyriphos solution of 0.5% concentration(5 ml/liter water) as required iv). Flooding the pit with water after making kiaries where required vi). Fertilise the pit by adding DAP 50gm, MOP 25 gm, 50gm neem oil cake and 50 gm stearammeal per pit at the time of planting- AZARDICTA INDICA ,Minimum 3.0/3.5m overall height,Minimum 100mm caliper,Multibranching at 2.0m from collar	Nos.	288.00		
410	Non SOR		Supply & Install Trees/ Palms inclusive of: i).Removal of rubbish/ all construction debris /site trash, and surplus earth inclusive with all leads and lift. ii). Treat the pit with Chloropyriphos solution of 0.5% concentration(5 ml/liter water) as required iv). Flooding the pit with water after making kiaries where required vi). Fertilise the pit by adding DAP 50gm, MOP 25 gm, 50gm neem oil cake and 50 gm stearammeal per pit at the time of planting- SPATHODEA CAMPANULATA ,Minimum 3.0/3.5m overall height,Minimum 100mm caliper,Multibranching at 1.5m from collar	Nos.	40.00		

Sno .	Ref.	Nos..	Description of Item	Unit	Quantity	Rat e (Rs)	Amoun t (Rs)
411	Non SOR		Supply & Install Trees/ Palms inclusive of: i).Removal of rubbish/ all construction debris /site trash, and surplus earth inclusive with all leads and lift. ii). Treat the pit with Chloropyriphos solution of 0.5% concentration(5 ml/liter water) as required iv). Flooding the pit with water after making kiaries where required vi). Fertilise the pit by adding DAP 50gm, MOP 25 gm, 50gm neem oil cake and 50 gm stearammeal per pit at the time of planting- STERCULIA ALATA ,Minimum 3.-3.5m overall height,Minimum 100mm caliper,Multibranching at 2.0m from collar	Nos.	510.00		
412	Non SOR		Supply & Install Trees/ Palms inclusive of: i).Removal of rubbish/ all construction debris /site trash, and surplus earth inclusive with all leads and lift. ii). Treat the pit with Chloropyriphos solution of 0.5% concentration(5 ml/liter water) as required iv). Flooding the pit with water after making kiaries where required vi). Fertilise the pit by adding DAP 50gm, MOP 25 gm, 50gm neem oil cake and 50 gm stearammeal per pit at the time of planting- TABEBUIA IMPETIGIN Nos.A-pink ,Minimum 3.0/3.5m overall height,Minimum 100mm caliper, Multibranching at 2.0m from collar	Nos.	150.00		
413	Non SOR		Supply & Install Trees/ Palms inclusive of: i).Removal of rubbish/ all construction debris /site trash, and surplus earth inclusive with all leads and lift. ii). Treat the pit with Chloropyriphos solution of 0.5% concentration(5 ml/liter water) as required iv). Flooding the pit with water after making kiaries where required vi). Fertilise the pit by adding DAP 50gm, MOP 25 gm, 50gm neem oil cake and 50 gm stearammeal per pit at the time of planting- ALBEZZIA LABBEK ,Minimum 3.0/3.5m overall height,Minimum 40-50mm caliper,Multibranching at 2.0m from collar	Nos.	170.00		

Sno .	Ref.	Nos..	Description of Item	Unit	Quantity	Rat e (Rs)	Amoun t (Rs)
414	Non SOR		Supply & Install Trees/ Palms inclusive of: i).Removal of rubbish/ all construction debris /site trash, and surplus earth inclusive with all leads and lift. ii). Treat the pit with Chloropyriphos solution of 0.5% concentration(5 ml/liter water) as required iv). Flooding the pit with water after making kiaries where required vi). Fertilise the pit by adding DAP 50gm, MOP 25 gm, 50gm neem oil cake and 50 gm stearammeal per pit at the time of planting- FICUS INFECTORIA ,Minimum 2.5m overall height,Minimum 40-50mm caliper,min. 8 fronds	Nos.	160.00		
415	Non SOR		Supply & Install Trees/ Palms inclusive of: i).Removal of rubbish/ all construction debris /site trash, and surplus earth inclusive with all leads and lift. ii). Treat the pit with Chloropyriphos solution of 0.5% concentration(5 ml/liter water) as required iv). Flooding the pit with water after making kiaries where required vi). Fertilise the pit by adding DAP 50gm, MOP 25 gm, 50gm neem oil cake and 50 gm stearammeal per pit at the time of planting- PLUMERIA ALBA ,FRANGIPANI,Minimum 3.0/3.5m overall height,Minimum 40-50mm caliper,Multibranching at 1.5m from collar	Nos.	45.00		
416	Non SOR		Supply & Install Trees/ Palms inclusive of: i).Removal of rubbish/ all construction debris /site trash, and surplus earth inclusive with all leads and lift. ii). Treat the pit with Chloropyriphos solution of 0.5% concentration(5 ml/liter water) as required iv). Flooding the pit with water after making kiaries where required vi). Fertilise the pit by adding DAP 50gm, MOP 25 gm, 50gm neem oil cake and 50 gm stearammeal per pit at the time of planting- PLUMERIA RUBRA ,RED Champa,Minimum 3.0/3.5m overall height,Minimum 40-50mm caliper,Multibranching at 1.5m from collar	Nos.	20.00		

Sno .	Ref.	Nos..	Description of Item	Unit	Quantity	Rat e (Rs)	Amoun t (Rs)
417	Non SOR		Supply & Install Trees/ Palms inclusive of: i).Removal of rubbish/ all construction debris /site trash, and surplus earth inclusive with all leads and lift. ii). Treat the pit with Chloropyriphos solution of 0.5% concentration(5 ml/liter water) as required iv). Flooding the pit with water after making kiaries where required vi). Fertilise the pit by adding DAP 50gm, MOP 25 gm, 50gm neem oil cake and 50 gm stearammeal per pit at the time of planting- Phoenix Sylvestris ,Minimum 2.5/3.0m overall height,Minimum 100mm caliper,Multibranching at 2.0m from collar	Nos.	400.00		
418	Non SOR		Supply & Install Trees/ Palms inclusive of: i).Removal of rubbish/ all construction debris /site trash, and surplus earth inclusive with all leads and lift. ii). Treat the pit with Chloropyriphos solution of 0.5% concentration(5 ml/liter water) as required iv). Flooding the pit with water after making kiaries where required vi). Fertilise the pit by adding DAP 50gm, MOP 25 gm, 50gm neem oil cake and 50 gm stearammeal per pit at the time of planting- DELONIX REGIA ,Minimum 2.0/2.5m overall height,Minimum 40-50mm caliper,Multibranching at 2.0m from collar	Nos.	10.00		
419	Non SOR		Supply & Install Trees/ Palms inclusive of: i).Removal of rubbish/ all construction debris /site trash, and surplus earth inclusive with all leads and lift. ii). Treat the pit with Chloropyriphos solution of 0.5% concentration(5 ml/liter water) as required iv). Flooding the pit with water after making kiaries where required vi). Fertilise the pit by adding DAP 50gm, MOP 25 gm, 50gm neem oil cake and 50 gm stearammeal per pit at the time of planting- DELONIX REGIA ,Minimum 3.0/3.5m overall height,Minimum 100mm caliper,Multibranching at 2.0m from collar	Nos.	272.80		

Sno .	Ref.	Nos..	Description of Item	Unit	Quantity	Rat e (Rs)	Amoun t (Rs)
420	Non SOR		Supply & Install Trees/ Palms inclusive of: i).Removal of rubbish/ all construction debris /site trash, and surplus earth inclusive with all leads and lift. ii). Treat the pit with Chloropyriphos solution of 0.5% concentration(5 ml/liter water) as required iv). Flooding the pit with water after making kiaries where required vi). Fertilise the pit by adding DAP 50gm, MOP 25 gm, 50gm neem oil cake and 50 gm stearammeal per pit at the time of planting- ERYTHRINA INDICA ,Minimum 2.0/2.5m overall height,Minimum 40-50mm caliper,Multibranching at 2.0m from collar	Nos.	10.00		
421	Non SOR		Supply & Install Trees/ Palms inclusive of: i).Removal of rubbish/ all construction debris /site trash, and surplus earth inclusive with all leads and lift. ii). Treat the pit with Chloropyriphos solution of 0.5% concentration(5 ml/liter water) as required iv). Flooding the pit with water after making kiaries where required vi). Fertilise the pit by adding DAP 50gm, MOP 25 gm, 50gm neem oil cake and 50 gm stearammeal per pit at the time of planting- CASSIA FISTULA ,Minimum 2.0/2.5m overall height,Minimum 40-50mm caliper,Multibranching at 2.0m from collar	Nos.	75.00		
422	Non SOR		Supply & Install Trees/ Palms inclusive of: i).Removal of rubbish/ all construction debris /site trash, and surplus earth inclusive with all leads and lift. ii). Treat the pit with Chloropyriphos solution of 0.5% concentration(5 ml/liter water) as required iv). Flooding the pit with water after making kiaries where required vi). Fertilise the pit by adding DAP 50gm, MOP 25 gm, 50gm neem oil cake and 50 gm stearammeal per pit at the time of planting- CASSIA JAVANICA ,Minimum 2.5m overall height,Minimum 40-50mm caliper	Nos.	50.00		

Sno .	Ref.	Nos..	Description of Item	Unit	Quantity	Rat e (Rs)	Amoun t (Rs)
423	Non SOR		Supply & Install Trees/ Palms inclusive of: i).Removal of rubbish/ all construction debris /site trash, and surplus earth inclusive with all leads and lift. ii). Treat the pit with Chloropyriphos solution of 0.5% concentration(5 ml/liter water) as required iv). Flooding the pit with water after making kiaries where required vi). Fertilise the pit by adding DAP 50gm, MOP 25 gm, 50gm neem oil cake and 50 gm stearammeal per pit at the time of planting- BUAHINIA VAREIGAETA ,Minimum 3.0/3.5m overall height,Minimum 40-50mm caliper,Multibranching at 1.5m from collar	Nos.	10.00		
424	Non SOR		Supply & Install Trees/ Palms inclusive of: i).Removal of rubbish/ all construction debris /site trash, and surplus earth inclusive with all leads and lift. ii). Treat the pit with Chloropyriphos solution of 0.5% concentration(5 ml/liter water) as required iv). Flooding the pit with water after making kiaries where required vi). Fertilise the pit by adding DAP 50gm, MOP 25 gm, 50gm neem oil cake and 50 gm stearammeal per pit at the time of planting- BOMBAX CEIBA ,Minimum 2.0/2.5m overall height,Minimum 40-50mm caliper,Multibranching at 2.0m from collar	Nos.	285.00		
425	Non SOR		Supply & Install Trees/ Palms inclusive of: i).Removal of rubbish/ all construction debris /site trash, and surplus earth inclusive with all leads and lift. ii). Treat the pit with Chloropyriphos solution of 0.5% concentration(5 ml/liter water) as required iv). Flooding the pit with water after making kiaries where required vi). Fertilise the pit by adding DAP 50gm, MOP 25 gm, 50gm neem oil cake and 50 gm stearammeal per pit at the time of planting- PHOENIX DACTYLIFERA ,Minimum 2.0/2.5m overall height,Minimum 100mm caliper,Multibranching at 2.0m from collar	Nos.	50.00		

Sno .	Ref.	Nos..	Description of Item	Unit	Quantity	Rate (Rs)	Amount (Rs)
426	Non SOR		Supply & Install Trees/ Palms inclusive of: i).Removal of rubbish/ all construction debris /site trash, and surplus earth inclusive with all leads and lift. ii). Treat the pit with Chloropyriphos solution of 0.5% concentration(5 ml/liter water) as required iv). Flooding the pit with water after making kiaries where required vi). Fertilise the pit by adding DAP 50gm, MOP 25 gm, 50gm neem oil cake and 50 gm stearammeal per pit at the time of planting- SYZYGIVM CUMINI ,Minimum 3.0/3.5m overall height,Minimum 100mm caliper,Multibranching at 2.0m from collar	Nos.	415.00		
			SHRUBS /PALMS				
427	Non SOR		Supply & Install Trees/ Palms inclusive of: i).Removal of rubbish/ all construction debris /site trash, and surplus earth inclusive with all leads and lift. ii). Treat the pit with Chloropyriphos solution of 0.5% concentration(5 ml/liter water) as required iv). Flooding the pit with water after making kiaries where required vi). Fertilise the pit by adding DAP 50gm, MOP 25 gm, 50gm neem oil cake and 50 gm stearammeal per pit at the time of planting- Cycus Revoluta (Cycus Palm) ,Minimum 0.3 M trunk height,Minimum 3 whorls with 10 leaves each.	Nos.	50.00		
428	Non SOR		Supply & Install Trees/ Palms inclusive of: i).Removal of rubbish/ all construction debris /site trash, and surplus earth inclusive with all leads and lift. ii). Treat the pit with Chloropyriphos solution of 0.5% concentration(5 ml/liter water) as required iv). Flooding the pit with water after making kiaries where required vi). Fertilise the pit by adding DAP 50gm, MOP 25 gm, 50gm neem oil cake and 50 gm stearammeal per pit at the time of planting- Hyophorbe Lagenicaulis (Bottle Palm) ,Minimum 0.75 M trunk height,Minimum 2 whorls with 05 leaves each.	Nos.	25.00		

Sno	Ref.	Nos..	Description of Item	Unit	Quantity	Rate (Rs)	Amount (Rs)
429	Non SOR		Supply & Install Shrubs / Palms inclusive of: i).Removal of rubbish/ all construction debris /site trash, and surplus earth inclusive with all leads and lift. ii). Treat the pit with Chloropyriphos solution of 0.5% oncentration(5 ml/liter water) as required iv). Flooding the pit with water after making kiaries where required vi). Fertilise the pit by adding DAP 50gm, MOP 25 gm, 50gm neem oil cake and 50 gm stearammeal per pit at the time of planting- ACALYPHA TRICOLUR ,Minimum 600mm height@600mmc/c,Bushy, Multibranching	Nos.	50.00		
430	Non SOR		Supply & Install Shrubs / Palms inclusive of: i).Removal of rubbish/ all construction debris /site trash, and surplus earth inclusive with all leads and lift. ii). Treat the pit with Chloropyriphos solution of 0.5% oncentration(5 ml/liter water) as required iv). Flooding the pit with water after making kiaries where required vi). Fertilise the pit by adding DAP 50gm, MOP 25 gm, 50gm neem oil cake and 50 gm stearammeal per pit at the time of planting- CALLIANDRA BREVIPES , Minimum 900mm height@900mmc/c,Bushy, Multibranching, Flowering.	Nos.	1000.00		
431	Non SOR		Supply & Install Shrubs / Palms inclusive of: i).Removal of rubbish/ all construction debris /site trash, and surplus earth inclusive with all leads and lift. ii). Treat the pit with Chloropyriphos solution of 0.5% oncentration(5 ml/liter water) as required iv). Flooding the pit with water after making kiaries where required vi). Fertilise the pit by adding DAP 50gm, MOP 25 gm, 50gm neem oil cake and 50 gm stearammeal per pit at the time of planting- ALLAMANDA NERIFOLIA ,Minimum 900mm height@900mmc/c,Bushy, Multibranching, Flowering	Nos.	50.00		
432	Non SOR		Supply & Install Shrubs / Palms inclusive of: i).Removal of rubbish/ all construction debris /site trash, and surplus earth inclusive with all leads and lift. ii). Treat the pit with Chloropyriphos solution of 0.5%	Nos.	2170.00		

Sno	Ref.	Nos..	Description of Item	Unit	Quantity	Rate (Rs)	Amount (Rs)
			oncentration(5 ml/liter water) as required iv). Flooding the pit with water after making kiaries where required vi). Fertilise the pit by adding DAP 50gm, MOP 25 gm, 50gm neem oil cake and 50 gm stearammeal per pit at the time of planting- LAGERSTROEMEA INDICA (Species Muve, white, Pink Red) CANDIDA ,Minimum 900mm height@900mmc/c,Bushy, Multibranching, Flowering				
433	Non SOR		Supply & Install Shrubs / Palms inclusive of: i).Removal of rubbish/ all construction debris /site trash, and surplus earth inclusive with all leads and lift. ii). Treat the pit with Chloropyriphos solution of 0.5% oncentration(5 ml/liter water) as required iv). Flooding the pit with water after making kiaries where required vi). Fertilise the pit by adding DAP 50gm, MOP 25 gm, 50gm neem oil cake and 50 gm stearammeal per pit at the time of planting- CALLIANDRA HAEMATOCEPHALLA ,Minimum 900mm height@900mmc/c,Bushy, Multibranching, Flowering.	Nos.	1000.00		
434	Non SOR		Supply & Install Shrubs / Palms inclusive of: i).Removal of rubbish/ all construction debris /site trash, and surplus earth inclusive with all leads and lift. ii). Treat the pit with Chloropyriphos solution of 0.5% oncentration(5 ml/liter water) as required iv). Flooding the pit with water after making kiaries where required vi). Fertilise the pit by adding DAP 50gm, MOP 25 gm, 50gm neem oil cake and 50 gm stearammeal per pit at the time of planting- Nerium oleander 'Petite Pink' Dwarf Pink , Minimum 900mm height@750mmc/c,Bushy, Multibranching, Flowering	Nos.	1450.00		
435	Non SOR		Supply & Install Shrubs / Palms inclusive of: i).Removal of rubbish/ all construction debris /site trash, and surplus earth inclusive with all leads and lift. ii). Treat the pit with Chloropyriphos solution of 0.5% oncentration(5 ml/liter water) as required iv). Flooding the pit with water after making kiaries where required vi). Fertilise the pit by adding DAP 50gm, MOP 25 gm, 50gm neem oil cake and 50	Nos.	8950.12		

Sno .	Ref.	Nos..	Description of Item	Unit	Quantity	Rat e (Rs)	Amoun t (Rs)
			gm stearammeal per pit at the time of planting- Nerium oleander 'Petite Pink' Dwarf Pink , Minimum 600mm height@450mmc/c,Bushy, Multibranching, Flowering				
436	Non SOR		Supply & Install Shrubs / Palms inclusive of: i).Removal of rubbish/ all construction debris /site trash, and surplus earth inclusive with all leads and lift. ii). Treat the pit with Chloropyriphos solution of 0.5% oncentration(5 ml/liter water) as required iv). Flooding the pit with water after making kiaries where required vi). Fertilise the pit by adding DAP 50gm, MOP 25 gm, 50gm neem oil cake and 50 gm stearammeal per pit at the time of planting- CASSIA BIFLORA ,Minimum 900mm height@900mmc/c,Bushy, Multibranching, Flowering	Nos.	80.00		
437	Non SOR		Supply & Install Shrubs / Palms inclusive of: i).Removal of rubbish/ all construction debris /site trash, and surplus earth inclusive with all leads and lift. ii). Treat the pit with Chloropyriphos solution of 0.5% oncentration(5 ml/liter water) as required iv). Flooding the pit with water after making kiaries where required vi). Fertilise the pit by adding DAP 50gm, MOP 25 gm, 50gm neem oil cake and 50 gm stearammeal per pit at the time of planting- CASSIA BIFLORA ,Minimum 1500mm height@2000mmc/c,Bushy, Multibranching, Flowering	Nos.	1663.00		
438	Non SOR		Supply & Install Shrubs / Palms inclusive of: i).Removal of rubbish/ all construction debris /site trash, and surplus earth inclusive with all leads and lift. ii). Treat the pit with Chloropyriphos solution of 0.5% oncentration(5 ml/liter water) as required iv). Flooding the pit with water after making kiaries where required vi). Fertilise the pit by adding DAP 50gm, MOP 25 gm, 50gm neem oil cake and 50 gm stearammeal per pit at the time of planting- CESTRUM ELEGANS ,Minimum 600mm height@600mmc/c,Bushy, Multibranching, Flowering	Nos.	25.00		

Sno	Ref.	Nos..	Description of Item	Unit	Quantity	Rate (Rs)	Amount (Rs)
439	Non SOR		Supply & Install Shrubs / Palms inclusive of: i).Removal of rubbish/ all construction debris /site trash, and surplus earth inclusive with all leads and lift. ii). Treat the pit with Chloropyriphos solution of 0.5% oncentration(5 ml/liter water) as required iv). Flooding the pit with water after making kiaries where required vi). Fertilise the pit by adding DAP 50gm, MOP 25 gm, 50gm neem oil cake and 50 gm stearammeal per pit at the time of planting- HAMELIA PATTENS ,Minimum 1500mm height@900mmc/c,Bushy, Multibranching	Nos.	2800.00		
440	Non SOR		Supply & Install Shrubs / Palms inclusive of: i).Removal of rubbish/ all construction debris /site trash, and surplus earth inclusive with all leads and lift. ii). Treat the pit with Chloropyriphos solution of 0.5% oncentration(5 ml/liter water) as required iv). Flooding the pit with water after making kiaries where required vi). Fertilise the pit by adding DAP 50gm, MOP 25 gm, 50gm neem oil cake and 50 gm stearammeal per pit at the time of planting- HAMELIA PATTENS ,Minimum 1500mm height@2000mmc/c,Bushy, Multibranching	Nos.	1663.00		
441	Non SOR		Supply & Install Shrubs / Palms inclusive of: i).Removal of rubbish/ all construction debris /site trash, and surplus earth inclusive with all leads and lift. ii). Treat the pit with Chloropyriphos solution of 0.5% oncentration(5 ml/liter water) as required iv). Flooding the pit with water after making kiaries where required vi). Fertilise the pit by adding DAP 50gm, MOP 25 gm, 50gm neem oil cake and 50 gm stearammeal per pit at the time of planting- GARDENIA JASMIN os. IDES ,Minimum 900mm height@900mmc/c,Bushy, Multibranching, Flowering	Nos.	920.00		
442	Non SOR		Supply & Install Shrubs / Palms inclusive of: i).Removal of rubbish/ all construction debris /site trash, and surplus earth inclusive with all leads and lift. ii). Treat the pit with Chloropyriphos solution of 0.5%	Nos.	1440.00		

Sno	Ref.	Nos..	Description of Item	Unit	Quantity	Rate (Rs)	Amount (Rs)
			oncentration(5 ml/liter water) as required iv). Flooding the pit with water after making kiaries where required vi). Fertilise the pit by adding DAP 50gm, MOP 25 gm, 50gm neem oil cake and 50 gm stearammeal per pit at the time of planting- HIBISCUS ROSA PROLIFIC ,Minimum 600mm height@600mmc/c, Bushy, Multibranching				
443	Non SOR		Supply & Install Shrubs / Palms inclusive of: i).Removal of rubbish/ all construction debris /site trash, and surplus earth inclusive with all leads and lift. ii). Treat the pit with Chloropyriphos solution of 0.5% oncentration(5 ml/liter water) as required iv). Flooding the pit with water after making kiaries where required vi). Fertilise the pit by adding DAP 50gm, MOP 25 gm, 50gm neem oil cake and 50 gm stearammeal per pit at the time of planting- HIBISCUS ALIPORE BEAUTY ,Minimum 600mm height@600mmc/c,Bushy, Multibranching, Flowering	Nos.	1440.00		
444	Non SOR		Supply & Install Shrubs / Palms inclusive of: i).Removal of rubbish/ all construction debris /site trash, and surplus earth inclusive with all leads and lift. ii). Treat the pit with Chloropyriphos solution of 0.5% oncentration(5 ml/liter water) as required iv). Flooding the pit with water after making kiaries where required vi). Fertilise the pit by adding DAP 50gm, MOP 25 gm, 50gm neem oil cake and 50 gm stearammeal per pit at the time of planting- HIBISCUS DAFFODIL YELLOW ,Minimum 600mm height@600mmc/c,Bushy, Multibranching, Flowering	Nos.	1440.00		
445	Non SOR		Supply & Install Shrubs / Palms inclusive of: i).Removal of rubbish/ all construction debris /site trash, and surplus earth inclusive with all leads and lift. ii). Treat the pit with Chloropyriphos solution of 0.5% oncentration(5 ml/liter water) as required iv). Flooding the pit with water after making kiaries where required vi). Fertilise the pit by adding DAP 50gm, MOP 25 gm, 50gm neem oil cake and 50 gm stearammeal per pit at the time of	Nos.	500.00		

Sno .	Ref.	Nos..	Description of Item	Unit	Quantity	Rate (Rs)	Amount (Rs)
			planting- HIBISCUS ORANGE GLORY ,Minimum 600mm height@600mmc/c,Bushy, Multibranching, Flowering				
446	Non SOR		Supply & Install Shrubs / Palms inclusive of: i).Removal of rubbish/ all construction debris /site trash, and surplus earth inclusive with all leads and lift. ii). Treat the pit with Chloropyriphos solution of 0.5% oncentration(5 ml/liter water) as required iv). Flooding the pit with water after making kiaries where required vi). Fertilise the pit by adding DAP 50gm, MOP 25 gm, 50gm neem oil cake and 50 gm stearammeal per pit at the time of planting- HIBISCUS HAWAIN WHITE ,Minimum 600mm height@600mmc/c,Bushy, Multibranching, Flowering	Nos.	550.00		
447	Non SOR		Supply & Install Shrubs / Palms inclusive of: i).Removal of rubbish/ all construction debris /site trash, and surplus earth inclusive with all leads and lift. ii). Treat the pit with Chloropyriphos solution of 0.5% oncentration(5 ml/liter water) as required iv). Flooding the pit with water after making kiaries where required vi). Fertilise the pit by adding DAP 50gm, MOP 25 gm, 50gm neem oil cake and 50 gm stearammeal per pit at the time of planting- HIBISCUS ROSA SINENSIS (RED SATIN) ,Minimum 600mm height@600mmc/c,Bushy, Multibranching, Flowering	Nos.	500.00		
448	Non SOR		Supply & Install Shrubs / Palms inclusive of: i).Removal of rubbish/ all construction debris /site trash, and surplus earth inclusive with all leads and lift. ii). Treat the pit with Chloropyriphos solution of 0.5% oncentration(5 ml/liter water) as required iv). Flooding the pit with water after making kiaries where required vi). Fertilise the pit by adding DAP 50gm, MOP 25 gm, 50gm neem oil cake and 50 gm stearammeal per pit at the time of planting- HIBISCUS SNos.WFLAKE ,Minimum 600mm height@600mmc/c, Bushy, Multibranching, Flowering	Nos.	1320.00		

Sno	Ref.	Nos..	Description of Item	Unit	Quantity	Rate (Rs)	Amount (Rs)
449	Non SOR		Supply & Install Shrubs / Palms inclusive of: i).Removal of rubbish/ all construction debris /site trash, and surplus earth inclusive with all leads and lift. ii). Treat the pit with Chloropyriphos solution of 0.5% oncentration(5 ml/liter water) as required iv). Flooding the pit with water after making kiaries where required vi). Fertilise the pit by adding DAP 50gm, MOP 25 gm, 50gm neem oil cake and 50 gm stearammeal per pit at the time of planting- IXORA CHENENSIS ,Minimum 600mm height@600mmc/c,Bushy, Multibranching, Flowering	Nos.	50.00		
450	Non SOR		Supply & Install Shrubs / Palms inclusive of: i).Removal of rubbish/ all construction debris /site trash, and surplus earth inclusive with all leads and lift. ii). Treat the pit with Chloropyriphos solution of 0.5% oncentration(5 ml/liter water) as required iv). Flooding the pit with water after making kiaries where required vi). Fertilise the pit by adding DAP 50gm, MOP 25 gm, 50gm neem oil cake and 50 gm stearammeal per pit at the time of planting- JASMINUM HUMILE ,Minimum 600mm height@600mmc/c,Bushy, Multibranching, Flowering	Nos.	25.00		
451	Non SOR		Supply & Install Shrubs / Palms inclusive of: i).Removal of rubbish/ all construction debris /site trash, and surplus earth inclusive with all leads and lift. ii). Treat the pit with Chloropyriphos solution of 0.5% oncentration(5 ml/liter water) as required iv). Flooding the pit with water after making kiaries where required vi). Fertilise the pit by adding DAP 50gm, MOP 25 gm, 50gm neem oil cake and 50 gm stearammeal per pit at the time of planting- JASMINUM PUBSCENS ,Minimum 600mm height@600mmc/c, Bushy, Multibranching, Flowering	Nos.	25.00		
452	Non SOR		Supply & Install Shrubs / Palms inclusive of: i).Removal of rubbish/ all construction debris /site trash, and surplus earth inclusive with all leads and lift. ii). Treat the pit with Chloropyriphos solution of 0.5% oncentration(5 ml/liter water) as required	Nos.	920.00		

Sno .	Ref.	Nos..	Description of Item	Unit	Quantity	Rat e (Rs)	Amoun t (Rs)
			iv). Flooding the pit with water after making kiaries where required vi). Fertilise the pit by adding DAP 50gm, MOP 25 gm, 50gm neem oil cake and 50 gm stearammeal per pit at the time of planting- LAGERSTROEMIA LANCESTERII ,Minimum 600mm height@600mmc/c,Bushy, Multibranching, Flowering				
453	Non SOR		Supply & Install Shrubs / Palms inclusive of: i).Removal of rubbish/ all construction debris /site trash, and surplus earth inclusive with all leads and lift. ii). Treat the pit with Chloropyriphos solution of 0.5% oncentration(5 ml/liter water) as required iv). Flooding the pit with water after making kiaries where required vi). Fertilise the pit by adding DAP 50gm, MOP 25 gm, 50gm neem oil cake and 50 gm stearammeal per pit at the time of planting- NERIUM OLEANDER ,Minimum 900mm height@900mmc/c,Bushy, Multibranching, Flowering	Nos.	820.00		
454	Non SOR		Supply & Install Shrubs / Palms inclusive of: i).Removal of rubbish/ all construction debris /site trash, and surplus earth inclusive with all leads and lift. ii). Treat the pit with Chloropyriphos solution of 0.5% oncentration(5 ml/liter water) as required iv). Flooding the pit with water after making kiaries where required vi). Fertilise the pit by adding DAP 50gm, MOP 25 gm, 50gm neem oil cake and 50 gm stearammeal per pit at the time of planting- TABERNAEMONTANA CORONERIA ,Minimum 600mm height@600mmc/c,Bushy, Multibranching, Flowering	Nos.	3100.00		
455	Non SOR		Supply & Install Shrubs / Palms inclusive of: i).Removal of rubbish/ all construction debris /site trash, and surplus earth inclusive with all leads and lift. ii). Treat the pit with Chloropyriphos solution of 0.5% oncentration(5 ml/liter water) as required iv). Flooding the pit with water after making kiaries where required vi). Fertilise the pit by adding DAP 50gm, MOP 25 gm, 50gm neem oil cake and 50 gm stearammeal per pit at the time of planting- LAGERSTROEMEA	Nos.	330.00		

Sno.	Ref.	Nos..	Description of Item	Unit	Quantity	Rate (Rs)	Amount (Rs)
			INDICA -ALIPORENSIS ,Minimum 2.5 height,Bushy, Multibranching, Flowering				
456	Non SOR		Supply & Install Trees/ Palms inclusive of: i).Removal of rubbish/ all construction debris /site trash, and surplus earth inclusive with all leads and lift. ii). Treat the pit with Chloropyriphos solution of 0.5% concentration(5 ml/liter water) as required iv). Flooding the pit with water after making kiaries where required vi). Fertilise the pit by adding DAP 50gm, MOP 25 gm, 50gm neem oil cake and 50 gm stearammeal per pit at the time of planting- CAESALPINIA PULCHERRIMA ,Minimum 0.3 M trunk height,Minimum 3 whorls with 10 leaves each.	Nos.	472.50		
457	Non SOR		Supply & Install Trees/ Palms inclusive of: i).Removal of rubbish/ all construction debris /site trash, and surplus earth inclusive with all leads and lift. ii). Treat the pit with Chloropyriphos solution of 0.5% concentration(5 ml/liter water) as required iv). Flooding the pit with water after making kiaries where required vi). Fertilise the pit by adding DAP 50gm, MOP 25 gm, 50gm neem oil cake and 50 gm stearammeal per pit at the time of planting- ROSES SUMMER S Nos.W ,Minimum 0.45 M trunk height@450 mm c/c,Minimum 2 whorls with 05 leaves each.	Nos.	1312.50		
458	Non SOR		Supply & Install Shrubs / Palms inclusive of: i).Removal of rubbish/ all construction debris /site trash, and surplus earth inclusive with all leads and lift. ii). Treat the pit with Chloropyriphos solution of 0.5% oncentration(5 ml/liter water) as required iv). Flooding the pit with water after making kiaries where required vi). Fertilise the pit by adding DAP 50gm, MOP 25 gm, 50gm neem oil cake and 50 gm stearammeal per pit at the time of planting- BAUHINIA TOMENTOSA ,Minimum 1500mm height@2000mmc/c,Bushy, Multibranching	Nos.	472.50		

Sno	Ref.	Nos..	Description of Item	Unit	Quantity	Rate (Rs)	Amount (Rs)
459	Non SOR		Supply & Install Shrubs / Palms inclusive of: i).Removal of rubbish/ all construction debris /site trash, and surplus earth inclusive with all leads and lift. ii). Treat the pit with Chloropyriphos solution of 0.5% oncentration(5 ml/liter water) as required iv). Flooding the pit with water after making kiaries where required vi). Fertilise the pit by adding DAP 50gm, MOP 25 gm, 50gm neem oil cake and 50 gm stearammeal per pit at the time of planting- CALLIANDRA EMARGINATA , Minimum 900mm height@900mmc/c,Bushy, Multibranching, Flowering.	Nos.	525.00		
460	Non SOR		Supply & Install Shrubs / Palms inclusive of: i).Removal of rubbish/ all construction debris /site trash, and surplus earth inclusive with all leads and lift. ii). Treat the pit with Chloropyriphos solution of 0.5% oncentration(5 ml/liter water) as required iv). Flooding the pit with water after making kiaries where required vi). Fertilise the pit by adding DAP 50gm, MOP 25 gm, 50gm neem oil cake and 50 gm stearammeal per pit at the time of planting- PLUMBAGO AURICULATA ,Minimum 900mm height@900mmc/c,Bushy, Multibranching, Flowering	Nos.	11550.00		
461	Non SOR		Supply & Install Shrubs / Palms inclusive of: i).Removal of rubbish/ all construction debris /site trash, and surplus earth inclusive with all leads and lift. ii). Treat the pit with Chloropyriphos solution of 0.5% oncentration(5 ml/liter water) as required iv). Flooding the pit with water after making kiaries where required vi). Fertilise the pit by adding DAP 50gm, MOP 25 gm, 50gm neem oil cake and 50 gm stearammeal per pit at the time of planting- LAGERSTROEMIA ROSEA ,Minimum 1500mm height@2000mmc/c,Bushy, Multibranching, Flowering	Nos.	282.20		
462	Non SOR		Supply & Install Shrubs / Palms inclusive of: i).Removal of rubbish/ all construction debris /site trash, and surplus earth inclusive with all leads and lift. ii). Treat the pit with Chloropyriphos solution of 0.5%	Nos.	550.00		

Sno	Ref.	Nos..	Description of Item	Unit	Quantity	Rate (Rs)	Amount (Rs)
			<p>oncentration(5 ml/liter water) as required iv). Flooding the pit with water after making kiaries where required vi). Fertilise the pit by adding DAP 50gm, MOP 25 gm, 50gm neem oil cake and 50 gm stearammeal per pit at the time of planting-LAGERSTROEMIA LANCASTERI, Minimum 1500mm height@2000mmc/c,Bushy, Multibranching, Flowering</p>				
463	Non SOR		<p>Supply & Install Shrubs / Palms inclusive of: i).Removal of rubbish/ all construction debris /site trash, and surplus earth inclusive with all leads and lift. ii). Treat the pit with Chloropyriphos solution of 0.5% oncentration(5 ml/liter water) as required iv). Flooding the pit with water after making kiaries where required vi). Fertilise the pit by adding DAP 50gm, MOP 25 gm, 50gm neem oil cake and 50 gm stearammeal per pit at the time of planting-HIBISCUS COOPERII, Minimum 900mm height@1000mmc/c,Bushy, Multibranching, Flowering</p>	Nos.	1380.00		
464	Non SOR		<p>Supply & Install Shrubs / Palms inclusive of: i).Removal of rubbish/ all construction debris /site trash, and surplus earth inclusive with all leads and lift. ii). Treat the pit with Chloropyriphos solution of 0.5% oncentration(5 ml/liter water) as required iv). Flooding the pit with water after making kiaries where required vi). Fertilise the pit by adding DAP 50gm, MOP 25 gm, 50gm neem oil cake and 50 gm stearammeal per pit at the time of planting-TABERNAEMONTANA VARIEGATED, Minimum 600mm height@600mmc/c,Bushy, Multibranching, Flowering</p>	Nos.	100.00		
465	Non SOR		<p>Supply & Install Shrubs / Palms inclusive of: i).Removal of rubbish/ all construction debris /site trash, and surplus earth inclusive with all leads and lift. ii). Treat the pit with Chloropyriphos solution of 0.5% oncentration(5 ml/liter water) as required iv). Flooding the pit with water after making kiaries where required vi). Fertilise the pit by adding DAP 50gm, MOP 25 gm, 50gm neem oil cake and 50 gm stearammeal per pit at the time of</p>	Nos.	820.00		

Sno.	Ref.	Nos..	Description of Item	Unit	Quantity	Rate (Rs)	Amount (Rs)
			planting- THEVETIA RED ,Minimum 900mm height@900mmc/c,Bushy, Multibranching, Flowering				
466	Non SOR		Supply &Install Shrubs inclusive of: i).Removal of rubbish/ all construction debris /site trash, and surplus earth inclusive with all leads and lift. ii). Treat the pit with Chloropyriphos solution of 0.5% concentration(5 ml/liter water) as required iv). Flooding the pit with water after making kiaries where required vi). Fertilise the pit by adding DAP 50gm, MOP 25 gm, 50gm neem oil cake and 50 gm stearammeal per pit at the time of planting.- SCHEFLERA ARBORICOLA ,Minimum 450mm height @450mmc/c,Minimum 3 runners per plant	Nos.	200.00		
467	Non SOR		Supply &Install ground covers/ Shade plants inclusive of: i).Removal of rubbish/ all construction debris /site trash, and surplus earth inclusive with all leads and lift. ii). Treat the pit with Chloropyriphos solution of 0.5% concentration(5 ml/liter water) as required iv). Flooding the pit with water after making kiaries where required vi). Fertilise the pit by adding DAP 50gm, MOP 25 gm, 50gm neem oil cake and 50 gm stearammeal per pit at the time of planting.- PHILODENRON BLACK CARDINAL ,Minimum 300mm height @450mmc/c,Minimum 3 runners per plant.	Nos.	100.00		
468	Non SOR		Supply & Install plants to form hedge, inclusive of: i).Removal of rubbish/ all construction debris /site trash, and surplus earth inclusive with all leads and lift. ii). Treat the pit with Chloropyriphos solution of 0.5% concentration(5 ml/liter water) as required iv). Flooding the pit with water after making kiaries where required vi). Fertilise the pit by adding DAP 50gm, MOP 25 gm, 50gm neem oil cake and 50 gm stearammeal per pit at the time of planting.- Hibiscus Roselle Ju Nos. Minimum 600mm height @600mmc/c,Bushy	Nos.	778.00		

Sno .	Ref.	Nos..	Description of Item	Unit	Quantity	Rat e (Rs)	Amoun t (Rs)
469	Non SOR		Supply & Install plants to form hedge, inclusive of: i).Removal of rubbish/ all construction debris /site trash, and surplus earth inclusive with all leads and lift. ii). Treat the pit with Chloropyriphos solution of 0.5% oncentration(5 ml/liter water) as required iv). Flooding the pit with water after making kiaries where required vi). Fertilise the pit by adding DAP 50gm, MOP 25 gm, 50gm neem oil cake and 50 gm stearammeal per pit at the time of planting.- Hibiscus Rosasinium Cooperii Minimum 600mm height @600mmc/c,Bushy	Nos.	1068.00		
470	Non SOR		Supply & Install plants to form hedge, inclusive of: i).Removal of rubbish/ all construction debris /site trash, and surplus earth inclusive with all leads and lift. ii). Treat the pit with Chloropyriphos solution of 0.5% oncentration(5 ml/liter water) as required iv). Flooding the pit with water after making kiaries where required vi). Fertilise the pit by adding DAP 50gm, MOP 25 gm, 50gm neem oil cake and 50 gm stearammeal per pit at the time of planting.- Hibiscus Mutabilis Minimum 600mm height @600mmc/c,Bushy	Nos.	778.00		
471	Non SOR		Supply & Install plants to form hedge, inclusive of: i).Removal of rubbish/ all construction debris /site trash, and surplus earth inclusive with all leads and lift. ii). Treat the pit with Chloropyriphos solution of 0.5% oncentration(5 ml/liter water) as required iv). Flooding the pit with water after making kiaries where required vi). Fertilise the pit by adding DAP 50gm, MOP 25 gm, 50gm neem oil cake and 50 gm stearammeal per pit at the time of planting.- Hibiscus Australian Rose Minimum 600mm height @600mmc/c,Bushy	Nos.	778.00		
472	Non SOR		Supply & Install plants to form hedge, inclusive of: i).Removal of rubbish/ all construction debris /site trash, and surplus earth inclusive with all leads and lift. ii). Treat the pit with Chloropyriphos solution of 0.5% oncentration(5 ml/liter water) as required iv). Flooding the pit with water after making kiaries where required vi). Fertilise the pit by adding DAP 50gm,	Nos.	778.00		

Sno .	Ref.	Nos..	Description of Item	Unit	Quantity	Rat e (Rs)	Amoun t (Rs)
			MOP 25 gm, 50gm neem oil cake and 50 gm stearamel per pit at the time of planting.- Hibiscus R.S. Kalijaba 600mm height @600mmc/c,Bushy				
473	Non SOR		Supply & Install Shrubs / Palms inclusive of: i).Removal of rubbish/ all construction debris /site trash, and surplus earth inclusive with all leads and lift. ii). Treat the pit with Chloropyriphos solution of 0.5% oncentration(5 ml/liter water) as required iv). Flooding the pit with water after making kiaries where required vi). Fertilise the pit by adding DAP 50gm, MOP 25 gm, 50gm neem oil cake and 50 gm stearamel per pit at the time of planting- BAUHINIA VARIEGATED ,Minimum 2.0m height@2m c/c,Bushy, Multibranching	Nos.	264.00		
474	Non SOR		Supply & Install Shrubs / Palms inclusive of: i).Removal of rubbish/ all construction debris /site trash, and surplus earth inclusive with all leads and lift. ii). Treat the pit with Chloropyriphos solution of 0.5% oncentration(5 ml/liter water) as required iv). Flooding the pit with water after making kiaries where required vi). Fertilise the pit by adding DAP 50gm, MOP 25 gm, 50gm neem oil cake and 50 gm stearamel per pit at the time of planting- HIBISCUS ALIPORENSIS ,Minimum 1500mm height@1000mmc/c,Bushy, Multibranching, Flowering.	Nos.	1380.00		
			GROUND COVERS				
475	Non SOR		Supply &Install ground covers/ Shade plants inclusive of: i).Removal of rubbish/ all construction debris /site trash, and surplus earth inclusive with all leads and lift. ii). Treat the pit with Chloropyriphos solution of 0.5% oncentration(5 ml/liter water) as required iv). Flooding the pit with water after making kiaries where required vi). Fertilise the pit by adding DAP 50gm, MOP 25 gm, 50gm neem oil cake and 50 gm stearamel per pit at the time of planting.- SPIDER LILY ,Minimum 200mm height @230mmc/c,Minimum 3 runners per plant	Sq m	264047.3 3		

Sno .	Ref.	Nos..	Description of Item	Unit	Quantity	Rat e (Rs)	Amoun t (Rs)
476	Non SOR		Supply &Install ground covers/ Shade plants inclusive of: i).Removal of rubbish/ all construction debris /site trash, and surplus earth inclusive with all leads and lift. ii). Treat the pit with Chloropyriphos solution of 0.5% oncentration(5 ml/liter water) as required iv). Flooding the pit with water after making kiaries where required vi). Fertilise the pit by adding DAP 50gm, MOP 25 gm, 50gm neem oil cake and 50 gm stearammeal per pit at the time of planting.- CESTRUM Nos.CTURNUM,Minimum 450mm height @300mmc/c,Minimum 3 runners per plant	Sq m	2625.00		
477	Non SOR		Supply &Install ground covers/ Shade plants inclusive of: i).Removal of rubbish/ all construction debris /site trash, and surplus earth inclusive with all leads and lift. ii). Treat the pit with Chloropyriphos solution of 0.5% oncentration(5 ml/liter water) as required iv). Flooding the pit with water after making kiaries where required vi). Fertilise the pit by adding DAP 50gm, MOP 25 gm, 50gm neem oil cake and 50 gm stearammeal per pit at the time of planting.- JASMINUM SAMBAC ,Minimum 300mm height @300mmc/c,Minimum 3 runners per plant	Sq m	1312.50		
478	Non SOR		Supply &Install ground covers/ Shade plants inclusive of: i).Removal of rubbish/ all construction debris /site trash, and surplus earth inclusive with all leads and lift. ii). Treat the pit with Chloropyriphos solution of 0.5% oncentration(5 ml/liter water) as required iv). Flooding the pit with water after making kiaries where required vi). Fertilise the pit by adding DAP 50gm, MOP 25 gm, 50gm neem oil cake and 50 gm stearammeal per pit at the time of planting.- VARIEGATED CHANDANI ,Minimum 300mm height @300mmc/c,Minimum 3 runners per plant	Sq m	1312.50		

Sno	Ref.	Nos..	Description of Item	Unit	Quantity	Rate (Rs)	Amount (Rs)
479	Non SOR		Supply &Install ground covers/ Shade plants inclusive of: i).Removal of rubbish/ all construction debris /site trash, and surplus earth inclusive with all leads and lift. ii). Treat the pit with Chloropyriphos solution of 0.5% concentration(5 ml/liter water) as required iv). Flooding the pit with water after making kiaries where required vi). Fertilise the pit by adding DAP 50gm, MOP 25 gm, 50gm neem oil cake and 50 gm stearammeal per pit at the time of planting.- DIANELLA ,Minimum 200mm height @230mmc/c,Minimum 3 runners per plant	Sq m	19366.20		
480	Non SOR		Supply &Install ground covers/ Shade plants inclusive of: i).Removal of rubbish/ all construction debris /site trash, and surplus earth inclusive with all leads and lift. ii). Treat the pit with Chloropyriphos solution of 0.5% concentration(5 ml/liter water) as required iv). Flooding the pit with water after making kiaries where required vi). Fertilise the pit by adding DAP 50gm, MOP 25 gm, 50gm neem oil cake and 50 gm stearammeal per pit at the time of planting.- WIDELIA ,Minimum 200mm height @150mmc/c,Minimum 3 runners per plant	Sq m	142657.60		
481	Non SOR		Supply &Install ground covers/ Shade plants inclusive of: i).Removal of rubbish/ all construction debris /site trash, and surplus earth inclusive with all leads and lift. ii). Treat the pit with Chloropyriphos solution of 0.5% concentration(5 ml/liter water) as required iv). Flooding the pit with water after making kiaries where required vi). Fertilise the pit by adding DAP 50gm, MOP 25 gm, 50gm neem oil cake and 50 gm stearammeal per pit at the time of planting.- PHALARIS ARUNDINACEA PICTA ,Minimum 200mm height @200mmc/c,Minimum 3 runners per plant	Sq m	48316.20		

Sno .	Ref.	Nos..	Description of Item	Unit	Quantity	Rat e (Rs)	Amoun t (Rs)
482	Non SOR		Supply &Install ground covers/ Shade plants inclusive of: i).Removal of rubbish/ all construction debris /site trash, and surplus earth inclusive with all leads and lift. ii). Treat the pit with Chloropyriphos solution of 0.5% oncentration(5 ml/liter water) as required iv). Flooding the pit with water after making kiaries where required vi). Fertilise the pit by adding DAP 50gm, MOP 25 gm, 50gm neem oil cake and 50 gm stearammeal per pit at the time of planting. -EUPHORBIA MILLI ,Minimum 450mm height @450mmc/c,Minimum 3 runners per plant	Sq m	20950.00		
483	HSR	33.9	Mixing earth and sludge or farm yard manure in proportion specified or as directed.	Cum	3334.53		
484	Non SOR		Supply & Install gound covers/ Shade plants inclusive of: i).Removal of rubbish/ all construction debris /site trash, and surplus earth inclusive with all leads and lift. ii). Treat the pit with Chloropyriphos solution of 0.5% oncentration(5 ml/liter water) as required iv). Flooding the pit with water after making kiaries where required vi). Fertilise the pit by adding DAP 50gm, MOP 25 gm, 50gm neem oil cake and 50 gm stearammeal per pit at the time of planting. -ALTERNENTHERA RED ,Minimum 150mm height @200mmc/c,Bushy	Sqm.	400.00		
485	Non SOR		Supply &Install ground covers/ Shade plants inclusive of: i).Removal of rubbish/ all construction debris /site trash, and surplus earth inclusive with all leads and lift. ii). Treat the pit with Chloropyriphos solution of 0.5% oncentration(5 ml/liter water) as required iv). Flooding the pit with water after making kiaries where required vi). Fertilise the pit by adding DAP 50gm, MOP 25 gm, 50gm neem oil cake and 50 gm stearammeal per pit at the time of planting. -ALTERNENTHERA SNos.W TOP ,Minimum 150mm height @200mmc/c,Bushy	Sqm.	400.00		

Sno .	Ref.	Nos..	Description of Item	Unit	Quantity	Rate (Rs)	Amount (Rs)
486	Non SOR		Supply &Install ground covers/ Shade plants inclusive of: i).Removal of rubbish/ all construction debris /site trash, and surplus earth inclusive with all leads and lift. ii). Treat the pit with Chloropyriphos solution of 0.5% concentration(5 ml/liter water) as required iv). Flooding the pit with water after making kiaries where required vi). Fertilise the pit by adding DAP 50gm, MOP 25 gm, 50gm neem oil cake and 50 gm stearammeal per pit at the time of planting.-ASPARAGUS DENSIFLORUS,Minimum 150mm height @200mmc/c,	Sqm.	400.00		
487	Non SOR		Supply &Install ground covers/ Shade plants inclusive of: i).Removal of rubbish/ all construction debris /site trash, and surplus earth inclusive with all leads and lift. ii). Treat the pit with Chloropyriphos solution of 0.5% concentration(5 ml/liter water) as required iv). Flooding the pit with water after making kiaries where required vi). Fertilise the pit by adding DAP 50gm, MOP 25 gm, 50gm neem oil cake and 50 gm stearammeal per pit at the time of planting.-ASPARAGUS SPRENGERI,Minimum 300mm height @200mmc/c,Minimum 3 runners per plant	Sqm.	400.00		
488	Non SOR		Supply &Install ground covers/ Shade plants inclusive of: i).Removal of rubbish/ all construction debris /site trash, and surplus earth inclusive with all leads and lift. ii). Treat the pit with Chloropyriphos solution of 0.5% concentration(5 ml/liter water) as required iv). Flooding the pit with water after making kiaries where required vi). Fertilise the pit by adding DAP 50gm, MOP 25 gm, 50gm neem oil cake and 50 gm stearammeal per pit at the time of planting.-CALADIUM HORTULANUM SPP MIX,Minimum 150mm height @200mmc/c,Minimum 3 runners per plant	Sqm.	400.00		

Sno .	Ref.	Nos..	Description of Item	Unit	Quantity	Rat e (Rs)	Amoun t (Rs)
489	Non SOR		Supply &Install ground covers/ Shade plants inclusive of: i).Removal of rubbish/ all construction debris /site trash, and surplus earth inclusive with all leads and lift. ii). Treat the pit with Chloropyriphos solution of 0.5% oncentration(5 ml/liter water) as required iv). Flooding the pit with water after making kiaries where required vi). Fertilise the pit by adding DAP 50gm, MOP 25 gm, 50gm neem oil cake and 50 gm stearammeal per pit at the time of planting.-CHLOROPHYTUM COSMOSUM,Minimum 150mm height @200mmc/c,Minimum 3 runners per plant	Sqm.	400.00		
490	Non SOR		Supply &Install ground covers/ Shade plants inclusive of: i).Removal of rubbish/ all construction debris /site trash, and surplus earth inclusive with all leads and lift. ii). Treat the pit with Chloropyriphos solution of 0.5% oncentration(5 ml/liter water) as required iv). Flooding the pit with water after making kiaries where required vi). Fertilise the pit by adding DAP 50gm, MOP 25 gm, 50gm neem oil cake and 50 gm stearammeal per pit at the time of planting.-CUPHEA HYYSOFOLIA,Minimum 150mm height @200mmc/c,	Sqm.	200.00		
491	Non SOR		Supply &Install ground covers/ Shade plants inclusive of: i).Removal of rubbish/ all construction debris /site trash, and surplus earth inclusive with all leads and lift. ii). Treat the pit with Chloropyriphos solution of 0.5% oncentration(5 ml/liter water) as required iv). Flooding the pit with water after making kiaries where required vi). Fertilise the pit by adding DAP 50gm, MOP 25 gm, 50gm neem oil cake and 50 gm stearammeal per pit at the time of planting.-IRESINE,Minimum 150mm height @200mmc/c,Minimum 3 runners per plant	Sqm.	200.00		
492	Non SOR		Supply &Install ground covers/ Shade plants inclusive of: i).Removal of rubbish/ all construction debris /site trash, and surplus earth inclusive with all leads and lift. ii). Treat the pit with Chloropyriphos solution of 0.5% oncentration(5 ml/liter water) as required iv). Flooding the pit with water after	Sqm.	700.00		

Sno .	Ref.	Nos..	Description of Item	Unit	Quantity	Rat e (Rs)	Amoun t (Rs)
			making kiaries where required vi). Fertilise the pit by adding DAP 50gm, MOP 25 gm, 50gm neem oil cake and 50 gm stearammeal per pit at the time of planting.- IPOMEA GOLDEANA ,Minimum 300mm height @200mmc/c,Minimum 3 runners per plant				
493	Non SOR		Supply &Install ground covers/ Shade plants inclusive of: i).Removal of rubbish/ all construction debris /site trash, and surplus earth inclusive with all leads and lift. ii). Treat the pit with Chloropyriphos solution of 0.5% oncentration(5 ml/liter water) as required iv). Flooding the pit with water after making kiaries where required vi). Fertilise the pit by adding DAP 50gm, MOP 25 gm, 50gm neem oil cake and 50 gm stearammeal per pit at the time of planting.- OPHIPOGON BLACK GRASS Minimum 200mm height @200mmc/c,Minimum 3 runners per plant	Sqm.	400.00		
494	Non SOR		Supply &Install ground covers/ Shade plants inclusive of: i).Removal of rubbish/ all construction debris /site trash, and surplus earth inclusive with all leads and lift. ii). Treat the pit with Chloropyriphos solution of 0.5% oncentration(5 ml/liter water) as required iv). Flooding the pit with water after making kiaries where required vi). Fertilise the pit by adding DAP 50gm, MOP 25 gm, 50gm neem oil cake and 50 gm stearammeal per pit at the time of planting.- SYNGONIUM EMERALD GREEN ,Minimum 150mm height @200mmc/cMinimum 3 runners per plant	Sqm.	400.00		
495	Non SOR		Supply &Install ground covers/ Shade Minimum 150mm height @200mmc/cplants inclusive of: i).Removal of rubbish/ all construction debris /site trash, and surplus earth inclusive with all leads and lift. ii). Treat the pit with Chloropyriphos solution of 0.5% oncentration(5 ml/liter water) as required iv). Flooding the pit with water after making kiaries where required vi). Fertilise the pit by adding DAP 50gm, MOP 25 gm, 50gm neem oil cake and 50 gm stearammeal per pit at the time of planting.- SYNGONIUM	Sqm.	400.00		

Sno .	Ref.	Nos..	Description of Item	Unit	Quantity	Rat e (Rs)	Amoun t (Rs)
			VAR,Minimum 150mm - 300mm height Minimum 3 runners per plant,				
496	Non SOR		Supply &Install ground covers/ Shade plants inclusive of: i).Removal of rubbish/ all construction debris /site trash, and surplus earth inclusive with all leads and lift. ii). Treat the pit with Chloropyriphos solution of 0.5% oncentration(5 ml/liter water) as required iv). Flooding the pit with water after making kiaries where required vi). Fertilise the pit by adding DAP 50gm, MOP 25 gm, 50gm neem oil cake and 50 gm stearammeal per pit at the time of planting.- TRADESCANTIA PALLIDA ,Minimum 150mm height @200mmc/c,Minimum 3 runners per plant	Sqm.	2510.00		
497	Non SOR		Supply &Install ground covers/ Shade plants inclusive of: i).Removal of rubbish/ all construction debris /site trash, and surplus earth inclusive with all leads and lift. ii). Treat the pit with Chloropyriphos solution of 0.5% oncentration(5 ml/liter water) as required iv). Flooding the pit with water after making kiaries where required vi). Fertilise the pit by adding DAP 50gm, MOP 25 gm, 50gm neem oil cake and 50 gm stearammeal per pit at the time of planting.- WEDELIA TRILOBATA ,Minimum 3 runners per plant,Minimum 150mm height @200mmc/c	Sqm.	4830.00		
498	Non SOR		Supply &Install ground covers/ Shade plants inclusive of: i).Removal of rubbish/ all construction debris /site trash, and surplus earth inclusive with all leads and lift. ii). Treat the pit with Chloropyriphos solution of 0.5% oncentration(5 ml/liter water) as required iv). Flooding the pit with water after making kiaries where required vi). Fertilise the pit by adding DAP 50gm, MOP 25 gm, 50gm neem oil cake and 50 gm stearammeal per pit at the time of planting.- ZEBRINA PENDULA ,Minimum 300mm height @250mmc/c,Minimum 3 runners per plant	Sqm.	2350.00		

Sno .	Ref.	Nos..	Description of Item	Unit	Quantity	Rate (Rs)	Amount (Rs)
499	Non SOR		Supply &Install ground covers/ Shade plants inclusive of: i).Removal of rubbish/ all construction debris /site trash, and surplus earth inclusive with all leads and lift. ii). Treat the pit with Chloropyriphos solution of 0.5% concentration(5 ml/liter water) as required iv). Flooding the pit with water after making kiaries where required vi). Fertilise the pit by adding DAP 50gm, MOP 25 gm, 50gm neem oil cake and 50 gm stearammeal per pit at the time of planting.-DRACENA MARGINATA TRICOLOUR,Minimum 300mm height @600mmc/c,Minimum 3 runners per plant	Sqm.	100.00		
500	Non SOR		Supply &Install ground covers/ Shade plants inclusive of: i).Removal of rubbish/ all construction debris /site trash, and surplus earth inclusive with all leads and lift. ii). Treat the pit with Chloropyriphos solution of 0.5% concentration(5 ml/liter water) as required iv). Flooding the pit with water after making kiaries where required vi). Fertilise the pit by adding DAP 50gm, MOP 25 gm, 50gm neem oil cake and 50 gm stearammeal per pit at the time of planting.-DRACENA SANDEREANA LUTEA,Minimum 300mm height @600mmc/c,Minimum 3 runners per plant	Sqm.	50.00		
501	Non SOR		Supply &Install ground covers/ Shade plants inclusive of: i).Removal of rubbish/ all construction debris /site trash, and surplus earth inclusive with all leads and lift. ii). Treat the pit with Chloropyriphos solution of 0.5% concentration(5 ml/liter water) as required iv). Flooding the pit with water after making kiaries where required vi). Fertilise the pit by adding DAP 50gm, MOP 25 gm, 50gm neem oil cake and 50 gm stearammeal per pit at the time of planting.-MARANTA ARUNDINACEA,Minimum 250mm height @300mmc/c	Sqm.	50.00		
502	Non SOR		Supply &Install ground covers/ Shade plants inclusive of: i).Removal of rubbish/ all construction debris /site trash, and surplus earth inclusive with all leads and lift. ii). Treat the pit with Chloropyriphos solution of 0.5% concentration(5 ml/liter water) as required	Sqm.	100.00		

Sno .	Ref.	Nos..	Description of Item	Unit	Quantity	Rat e (Rs)	Amoun t (Rs)
			iv). Flooding the pit with water after making kiaries where required vi). Fertilise the pit by adding DAP 50gm, MOP 25 gm, 50gm neem oil cake and 50 gm stearammeal per pit at the time of planting.- OPHIOPOGON GREEN VAR, Minimum 200mm height @200mmc/c,Minimum 3 runners per plant				
503	Non SOR		Supply &Install ground covers/ Shade plants inclusive of: i).Removal of rubbish/ all construction debris /site trash, and surplus earth inclusive with all leads and lift. ii). Treat the pit with Chloropyriphos solution of 0.5% oncentration(5 ml/liter water) as required iv). Flooding the pit with water after making kiaries where required vi). Fertilise the pit by adding DAP 50gm, MOP 25 gm, 50gm neem oil cake and 50 gm stearammeal per pit at the time of planting.- SPATHEPHYLUM CLEVELANDI ,Minimum 200mm height @200mmc/c,Minimum 3 runners per plant	Sqm.	50.00		
504	Non SOR		Supply &Install ground covers/ Shade plants inclusive of: i).Removal of rubbish/ all construction debris /site trash, and surplus earth inclusive with all leads and lift. ii). Treat the pit with Chloropyriphos solution of 0.5% oncentration(5 ml/liter water) as required iv). Flooding the pit with water after making kiaries where required vi). Fertilise the pit by adding DAP 50gm, MOP 25 gm, 50gm neem oil cake and 50 gm stearammeal per pit at the time of planting.- SYNGONIUM BUTTERFLY ,Minimum 200mm height @200mmc/c,Minimum 3 runners per plant	Sqm.	380.00		
505	Non SOR		Supply &Install ground covers/ Shade plants inclusive of: i).Removal of rubbish/ all construction debris /site trash, and surplus earth inclusive with all leads and lift. ii). Treat the pit with Chloropyriphos solution of 0.5% oncentration(5 ml/liter water) as required iv). Flooding the pit with water after making kiaries where required vi). Fertilise the pit by adding DAP 50gm, MOP 25 gm, 50gm neem oil cake and 50 gm stearammeal per pit at the time of planting.- SYNGONIUM RED ,Minimum	Sqm.	400.00		

Sno .	Ref.	Nos..	Description of Item	Unit	Quantity	Rate (Rs)	Amount (Rs)
			200mm height @200mmc/c,Minimum 3 runners per plant				
506	Non SOR		Supply &Install ground covers/ Shade plants inclusive of: i).Removal of rubbish/ all construction debris /site trash, and surplus earth inclusive with all leads and lift. ii). Treat the pit with Chloropyriphos solution of 0.5% oncentration(5 ml/liter water) as required iv). Flooding the pit with water after making kiaries where required vi). Fertilise the pit by adding DAP 50gm, MOP 25 gm, 50gm neem oil cake and 50 gm stearammeal per pit at the time of planting.-SYNGONIUM GOLDEN/WHITE,Minimum 200mm height @200mmc/c,Minimum 3 runners per plant	Sqm.	400.00		
507	Non SOR		Supply &Install ground covers/ Shade plants inclusive of: i).Removal of rubbish/ all construction debris /site trash, and surplus earth inclusive with all leads and lift. ii). Treat the pit with Chloropyriphos solution of 0.5% oncentration(5 ml/liter water) as required iv). Flooding the pit with water after making kiaries where required vi). Fertilise the pit by adding DAP 50gm, MOP 25 gm, 50gm neem oil cake and 50 gm stearammeal per pit at the time of planting.-Spathiphyllum wallisii. (Peace Lily),Minimum 200mm height @200mmc/c,Minimum 3 runners per plant	Sqm.	50.00		
			HEDGES				
508	Non SOR		Supply & Install plants to form hedge, inclusive of: i).Removal of rubbish/ all construction debris /site trash, and surplus earth inclusive with all leads and lift. ii). Treat the pit with Chloropyriphos solution of 0.5% oncentration(5 ml/liter water) as required iv). Flooding the pit with water after making kiaries where required vi). Fertilise the pit by adding DAP 50gm, MOP 25 gm, 50gm neem oil cake and 50 gm stearammeal per pit at the time of planting.- DWARF CHANDNI Minimum 450mm height @450mmc/c,Bushy	Rmt	1890.00		

Sno .	Ref.	Nos..	Description of Item	Unit	Quantity	Rat e (Rs)	Amoun t (Rs)
509	Non SOR		Supply & Install plants to form hedge, inclusive of: i).Removal of rubbish/ all construction debris /site trash, and surplus earth inclusive with all leads and lift. ii). Treat the pit with Chloropyriphos solution of 0.5% concentration(5 ml/liter water) as required iv). Flooding the pit with water after making kiaries where required vi). Fertilise the pit by adding DAP 50gm, MOP 25 gm, 50gm neem oil cake and 50 gm stearammeal per pit at the time of planting.- FICUS RETUSA Minimum 450mm height @450mmc/c,Bushy	Rmt	2494.50		
510	Non SOR		Supply & Install plants to form hedge, inclusive of: i).Removal of rubbish/ all construction debris /site trash, and surplus earth inclusive with all leads and lift. ii). Treat the pit with Chloropyriphos solution of 0.5% concentration(5 ml/liter water) as required iv). Flooding the pit with water after making kiaries where required vi). Fertilise the pit by adding DAP 50gm, MOP 25 gm, 50gm neem oil cake and 50 gm stearammeal per pit at the time of planting.- FICUS BENJAMINA Minimum 450mm height @450mmc/c,Bushy	Rmt	2494.50		
511	Non SOR		Supply & Install plants to form hedge, inclusive of: i).Removal of rubbish/ all construction debris /site trash, and surplus earth inclusive with all leads and lift. ii). Treat the pit with Chloropyriphos solution of 0.5% concentration(5 ml/liter water) as required iv). Flooding the pit with water after making kiaries where required vi). Fertilise the pit by adding DAP 50gm, MOP 25 gm, 50gm neem oil cake and 50 gm stearammeal per pit at the time of planting.- FURCRAEA Minimum 450mm height @900mmc/c,Bushy	Rmt	6728.00		
512	Non SOR		Supply & Install plants to form hedge , inclusive of: i).Removal of rubbish/ all construction debris /site trash, and surplus earth inclusive with all leads and lift. ii). Treat the pit with Chloropyriphos solution of 0.5% concentration(5 ml/liter water) as required iv). Flooding the pit with water after making kiaries where required vi). Fertilise the pit by adding DAP 50gm, MOP 25 gm, 50gm neem oil cake and 50	Rmt	1922.00		

Sno	Ref.	Nos..	Description of Item	Unit	Quantity	Rate (Rs)	Amount (Rs)
			gm stearammeal per pit at the time of planting.- MURRAYA EXOTICA ,Minimum 300mm height @300mmc/c,Bushy/ Compact				
513	Non SOR		Supply & Install plants to form hedge inclusive of: i).Removal of rubbish/ all construction debris /site trash, and surplus earth inclusive with all leads and lift. ii). Treat the pit with Chloropyriphos solution of 0.5% oncentration(5 ml/liter water) as required iv). Flooding the pit with water after making kiaries where required vi). Fertilise the pit by adding DAP 50gm, MOP 25 gm, 50gm neem oil cake and 50 gm stearammeal per pit at the time of planting.- CLERODENRON MACROSIPHON ,Minimum 450mm height @200mmc/c,Bushy	Rmt	200.00		
514	Non SOR		Supply & Install plants to form hedge, inclusive of: i).Removal of rubbish/ all construction debris /site trash, and surplus earth inclusive with all leads and lift. ii). Treat the pit with Chloropyriphos solution of 0.5% oncentration(5 ml/liter water) as required iv). Flooding the pit with water after making kiaries where required vi). Fertilise the pit by adding DAP 50gm, MOP 25 gm, 50gm neem oil cake and 50 gm stearammeal per pit at the time of planting.- BOUGANVILLA PINK ,Minimum 300 mm height @300mmc/c,Bushy	Rmt	960.00		
515	Non SOR		Supply & Install plants to form hedge, inclusive of: i).Removal of rubbish/ all construction debris /site trash, and surplus earth inclusive with all leads and lift. ii). Treat the pit with Chloropyriphos solution of 0.5% oncentration(5 ml/liter water) as required iv). Flooding the pit with water after making kiaries where required vi). Fertilise the pit by adding DAP 50gm, MOP 25 gm, 50gm neem oil cake and 50 gm stearammeal per pit at the time of planting.- CLERODENDRON INERME ,Minimum 300 mm height @200mmc/c,Bushy	Rmt	250.00		
516	Non SOR		Supply & Install plants to form hedge, inclusive of: i).Removal of rubbish/ all construction debris /site trash, and surplus earth inclusive with all leads and lift. ii). Treat the pit with	Rmt	1038.00		

Sno .	Ref.	Nos..	Description of Item	Unit	Quantity	Rat e (Rs)	Amoun t (Rs)
			Chloropyriphos solution of 0.5% oncentration(5 ml/liter water) as required iv). Flooding the pit with water after making kiaries where required vi). Fertilise the pit by adding DAP 50gm, MOP 25 gm, 50gm neem oil cake and 50 gm stearammeal per pit at the time of planting.- DURANTA GOLDEN PLUMERI Minimum 300mm height @200mmc/c,Bushy				
517	Non SOR		Supply & Install plants to form hedge, inclusive of: i).Removal of rubbish/ all construction debris /site trash, and surplus earth inclusive with all leads and lift. ii). Treat the pit with Chloropyriphos solution of 0.5% oncentration(5 ml/liter water) as required iv). Flooding the pit with water after making kiaries where required vi). Fertilise the pit by adding DAP 50gm, MOP 25 gm, 50gm neem oil cake and 50 gm stearammeal per pit at the time of planting.- FICUS PANDA Minimum 450 mm height @450mmc/c,Bushy	RMT	920.00		
518	Non SOR		Supply & Install plants to form hedge, inclusive of: i).Removal of rubbish/ all construction debris /site trash, and surplus earth inclusive with all leads and lift. ii). Treat the pit with Chloropyriphos solution of 0.5% oncentration(5 ml/liter water) as required iv). Flooding the pit with water after making kiaries where required vi). Fertilise the pit by adding DAP 50gm, MOP 25 gm, 50gm neem oil cake and 50 gm stearammeal per pit at the time of planting.- HEMELIA PATENS Minimum 450mm height @450mmc/c,Bushy	Rmt	920.00		
519	Non SOR		Supply & Install plants to form hedge, inclusive of: i).Removal of rubbish/ all construction debris /site trash, and surplus earth inclusive with all leads and lift. ii). Treat the pit with Chloropyriphos solution of 0.5% oncentration(5 ml/liter water) as required iv). Flooding the pit with water after making kiaries where required vi). Fertilise the pit by adding DAP 50gm, MOP 25 gm, 50gm neem oil cake and 50 gm stearammeal per pit at the time of planting.- FICUS PANDA VAREIGATED Minimum 450mm height @450mmc/c,Bushy	Rmt	100.00		

Sno	Ref.	Nos..	Description of Item	Unit	Quantity	Rate (Rs)	Amount (Rs)
520	Non SOR		Supply & Install plants to form hedge, inclusive of: i).Removal of rubbish/ all construction debris /site trash, and surplus earth inclusive with all leads and lift. ii). Treat the pit with Chloropyriphos solution of 0.5% concentration(5 ml/liter water) as required iv). Flooding the pit with water after making kiaries where required vi). Fertilise the pit by adding DAP 50gm, MOP 25 gm, 50gm neem oil cake and 50 gm stearammeal per pit at the time of planting.- ACALYPHA WILKENSIANA RED Minimum 300mm height @300mmc/c,Bushy	Rmt	1410.00		
521	Non SOR		Supply & Install plants to form hedge, inclusive of: i).Removal of rubbish/ all construction debris /site trash, and surplus earth inclusive with all leads and lift. ii). Treat the pit with Chloropyriphos solution of 0.5% concentration(5 ml/liter water) as required iv). Flooding the pit with water after making kiaries where required vi). Fertilise the pit by adding DAP 50gm, MOP 25 gm, 50gm neem oil cake and 50 gm stearammeal per pit at the time of planting.- IXORA DWARF YELLOW Minimum 300mm height @300mmc/c,Bushy	Rmt	700.00		
522	Non SOR		Supply & Install plants to form hedge, inclusive of: i).Removal of rubbish/ all construction debris /site trash, and surplus earth inclusive with all leads and lift. ii). Treat the pit with Chloropyriphos solution of 0.5% concentration(5 ml/liter water) as required iv). Flooding the pit with water after making kiaries where required vi). Fertilise the pit by adding DAP 50gm, MOP 25 gm, 50gm neem oil cake and 50 gm stearammeal per pit at the time of planting.- TABERNAEMONTANA CORONERIA VARIEGATED Minimum 450 mm height @450mmc/c,Bushy	Rmt	50.00		
523	Non SOR		Supply & Install plants to form hedge, inclusive of: i).Removal of rubbish/ all construction debris /site trash, and surplus earth inclusive with all leads and lift. ii). Treat the pit with Chloropyriphos solution of 0.5% concentration(5 ml/liter water) as required iv). Flooding the pit with water after	Rmt	50.00		

Sno .	Ref.	Nos..	Description of Item	Unit	Quantity	Rat e (Rs)	Amoun t (Rs)
			making kiaries where required vi). Fertilise the pit by adding DAP 50gm, MOP 25 gm, 50gm neem oil cake and 50 gm stearammeal per pit at the time of planting.- ACALYPHA WILKENSIANA GREEN Minimum 300mm height @300mmc/c,Bushy				
524	Non SOR		Supply & Install plants to form hedge, inclusive of: i).Removal of rubbish/ all construction debris /site trash, and surplus earth inclusive with all leads and lift. ii). Treat the pit with Chloropyriphos solution of 0.5% oncentration(5 ml/liter water) as required iv). Flooding the pit with water after making kiaries where required vi). Fertilise the pit by adding DAP 50gm, MOP 25 gm, 50gm neem oil cake and 50 gm stearammeal per pit at the time of planting.- RAPHIS EXELSA Minimum450 mm height @450mmc/c,Bushy	Rmt	50.00		
525	Non SOR		Supply & Install plants to form hedge, inclusive of: i).Removal of rubbish/ all construction debris /site trash, and surplus earth inclusive with all leads and lift. ii). Treat the pit with Chloropyriphos solution of 0.5% oncentration(5 ml/liter water) as required iv). Flooding the pit with water after making kiaries where required vi). Fertilise the pit by adding DAP 50gm, MOP 25 gm, 50gm neem oil cake and 50 gm stearammeal per pit at the time of planting.- Russelia juncea Minimum 300 mm height @200mmc/c,Bushy	Rmt	50.00		
526	Non SOR		Supply & Install plants to form hedge, inclusive of: i).Removal of rubbish/ all construction debris /site trash, and surplus earth inclusive with all leads and lift. ii). Treat the pit with Chloropyriphos solution of 0.5% oncentration(5 ml/liter water) as required iv). Flooding the pit with water after making kiaries where required vi). Fertilise the pit by adding DAP 50gm, MOP 25 gm, 50gm neem oil cake and 50 gm stearammeal per pit at the time of planting.- ERANTHEMUM BICOLOUR Minimum 450mm height @450mmc/c,Bushy	Rmt	500.00		

Sno.	Ref.	Nos..	Description of Item	Unit	Quantity	Rate (Rs)	Amount (Rs)
527	Non SOR		Supply & Install plants to form hedge, inclusive of: i).Removal of rubbish/ all construction debris /site trash, and surplus earth inclusive with all leads and lift. ii). Treat the pit with Chloropyriphos solution of 0.5% concentration(5 ml/liter water) as required iv). Flooding the pit with water after making kiaries where required vi). Fertilise the pit by adding DAP 50gm, MOP 25 gm, 50gm neem oil cake and 50 gm stearamel per pit at the time of planting.- JASMINUM SAMBAC MOTIA Minimum 450 mm height @450mmc/c,Bushy	Rmt	50.00		
528	Non SOR		Supply & Install plants to form hedge, inclusive of: i).Removal of rubbish/ all construction debris /site trash, and surplus earth inclusive with all leads and lift. ii). Treat the pit with Chloropyriphos solution of 0.5% concentration(5 ml/liter water) as required iv). Flooding the pit with water after making kiaries where required vi). Fertilise the pit by adding DAP 50gm, MOP 25 gm, 50gm neem oil cake and 50 gm stearamel per pit at the time of planting.- MURRAYA PANICULATA Minimum 300 mm height @300mmc/c,Bushy	Rmt	50.00		
			TOPIARY				
529	Non SOR		Supply and install topiary of various shapes such as deer with shoulder height minimum 850 mm as per given specifications in RFP.	Nos.	30.00		
			MANURE				
530	HSR	33.1	Supplying at site of work well-decayed farm-yard manure, from any available source, approved by the Engineer-in-charge including screening and stacking.	Cum	4563.38		
531	HSR	33.2	Supplying site of work-Deoiled Neem-Cake duly packed in used bags	Quintal	244.07		
532	HSR	33.3	Supplying at site of work sludge duly stacked at site.	Cum	1369.01		
			OPERATION AND MAINTENANCE				
			MAINTENANCE OF ROAD				
533	Non SOR		Routine Maintenance in carrying out repair of potholes / patches, repair of shoulders, cleaning of drains / clearing of roadway, clearing / removal of vegetation / fallen tree on carriageway /dead animals etc. complete as per technical specifications -for 1st year	year	1.00		

Sno	Ref.	Nos..	Description of Item	Unit	Quantity	Rate (Rs)	Amount (Rs)
534	Non SOR		O & M Scope of Road as mentioned in S.Nos. 533 -for 2 nd year	year	1.00		
535	Non SOR		O & M Scope of Road as mentioned in S.Nos.. 533 -for 3rd year	year	1.00		
536	Non SOR		O & M Scope of Road as mentioned in S.Nos.. 533 -for 4th year	year	1.00		
537	Non SOR		O & M Scope of Road as mentioned in S.Nos..533 -for 5th year	year	1.00		
			MAINTENANCE OF UTILITY				
538	Non SOR		Routine Maintenance in carrying out repair of Storm Water System,Sewerage System,Water Supply System, Utility Duct complete as per Ttechnical specifications or as approved by Engineer-in-charge,-for 1st year	year	1.00		
539	Non SOR		O & M Scope of Utility on Road as mentioned in S.Nos..538 -for 2 nd year	year	1.00		
540	Non SOR		O & M Scope of Utility on Road as mentioned in S.Nos.538-for 3rd year	year	1.00		
541	Non SOR		O & M Scope of Utility on Road as mentioned in S.Nos.538 -for 4 th year	year	1.00		
542	Non SOR		O & M Scope of Utility on Road as mentioned in S.Nos.538 -for 5th year	year	1.00		
			MAINTENANCE OF ELECTRICAL WORKS				
543	Non SOR		Providing O & M service as indicated in the scope of work for O & M. This includes but Not limited to the supply of Man power, Labour, Equipmets, tools & tackles etc for mainting reliable power network. Contractor has to do contract for 5 years including DLP (Defect Liability Period). Scope includes all routin maintaince, attending the fault and restore power supply immidiately, making alternate power supply arrangement during the maintance, replacement of faulty componant, maintain daily/weekly and monthly report and submit to DHBVN. Working with DHBVN with close coordination. - for 1st year	year	1.00		
544	Non SOR		O & M Scope of Electrical works on Road as mentioned in S.Nos..543 -for 2 nd year	year	1.00		
545	Non SOR		O & M Scope of Electrical works on Road as mentioned in S.Nos.543 -for 3rd year	year	1.00		
546	Non SOR		O & M Scope of Electrical works as mentioned in S.Nos..543 -for 4 th year	year	1.00		
547	Non SOR		O & M Scope of Electrical works as mentioned in S.Nos..543-for 5th year	year	1.00		

Sno .	Ref.	Nos..	Description of Item	Unit	Quantity	Rate (Rs)	Amount (Rs)
			MAINTENANCE OF LANDSCAPE WORKS				
548	Non SOR		Providing O& M service as indicated in the scope of work, This includes but Not limited to the supply of Manpower, Labour, Equipments, Tools & Tackles, water, Pumps, Security, Spares of Installed Equipments, Complete maintenance of the entire Park features having as per yard stick in the Park area i.e. lawn trees, shrubs, hedge, flower beds, foliage, creepers etc. including hoeing, weeding pruning replacement of plants, gap filling, watering, mowing of lawn, grass cutting by lawn mover and brush cutter , removal of Park waste, applying insecticide, pesticide & fertilizers(whenever required) top dressing of lawn with good earth and manure and maintenance of other park related works as directed by office-in-charge (Cost of Good Earth, water Manure, Fertilizer, Insecticide,Pesticide , lawn mover and brush cutter with fuel will be calculated as per actuals & other T & P material/articles shall be provided by the contractor.)-)-Contractor shall maintained as per scope of work for maintenance discribed in RFP and maintained as direction of the Engineer-in-charge - for 1st Year.	year	1.00		
549	Non SOR		O & M Scope of Landscaping works on Road as mentioned in S.Nos..548 -for 2nd year	year	1.00		
550	Non SOR		O & M Scope of Landscaping works on Road as mentioned in S.Nos...548-for 3rd year	year	1.00		
551	Non SOR		O & M Scope of Landscaping works as mentioned in S.Nos.548 -for 4th year	year	1.00		
552	Non SOR		O & M Scope of Landscaping works as mentioned in S.Nos..548 -for 5th year	year	1.00		

SECTION 5: GENERAL CONDITIONS OF CONTRACT (GCC).

The GCC applies for entire duration of the contract period (Construction, Operation and Maintenance Period)

1 Security /Retention Money

a. Performance Security

The Performance Security equal to 5% of the contract price shall be provided to the Employer not later than the date specified in the Letter of Acceptance and shall be issued in an amount and form by a bank or surety acceptable to the Employer, and denominated in Indian Rupees. In case the time of completion is extended, the validity of performance security shall be correspondingly extended. It carries no interest and is returned to the contractor after the date specified in the contract. The EMD shall be returned at the signing of the agreement only upon receiving upon the Performance Security and signing of the Agreement.

a) An amount equal to 50 % value of the Performance security deposit in the form of Bank Guarantee as above shall be released on successful completion of one calendar year of the Defects Liability Period.

b) Balance amount equal to 50 % value of the Performance security deposit in the form of Bank Guarantee as above shall be released on successful completion of Two Calendar Years of the Defects Liability Period and providing another additional Performance Security in the form of BG of 10% of value of the balance Operation and Maintenance cost.

The BG submitted in lieu of O & M shall be released upon issue of certificate for successful completion of O& M period.

b. Additional Performance Security:

If the rate quoted by the lowest Bidder (L1) considered to be unbalanced in relation to the Authority's estimated of cost of work to be performed under the contract, the Chief Executive Officer then may require giving the Bidder notice to submit detailed price/ rate analysis of major items of the work. The bidder shall submit the rate analysis within 7 days of such notice so as to demonstrate the internal consistency of these price(s)/rate(s) with his quoted price(s)/rate(s). After revaluation by tender sanctioning authority, Chief Executive Officer may require the Bidder to submit 5 % additional Security over the performance security in the form of B.G., which shall be refunded along with the Second instalment of the normal Security Deposit (After four months of completion of successful operation period of works). In the event, contractor fails to complete the work to the satisfaction of the authority or abandoned the work incomplete, the authority may forfeit this 5 % additional Performance Security Deposit along with performance security and Security deposit & the agreement shall be terminated and action shall be taken accordingly. In case if the lowest Bidder, whose rates quoted, is considered to be unbalanced, does not agree to deposit additional 5 % Security Deposit then his bid may be rejected by the sanctioning authority and earnest money shall be forfeited

c. Retention Money

The Employer shall retain 5 % (Five Percent) from the payment made to the contractor in the running bills until completion of the whole of the Works up to maximum 5% of the contract value. On completion of the whole of the Works half the total amount retained is repaid to the Contractor and balance half when the Defects Liability Period has passed and the Engineer has certified that all Defects notified by the Engineer to the Contractor before the end of defect liability period have been corrected. On completion of the whole works, the contractor may substitute the balance half retention money with an "on demand" Bank guarantee.

2. The Bidders is /are to provide everything of every sort and kind (with the exception noted in the schedule attached) which may be necessary and requisite for the due and proper execution of the several works included in the contract according to the true intent and meaning of the drawings and specifications taken together, which are to be signed by the Engineer in Charge designated by the

FSCL (herein after called the Engineer-In-Charge) and the Bidder whether the same may not be particularly described in the specifications or shown on the drawings, provided that the same are reasonably and obviously to be inferred there from and in case of any discrepancy between the drawings and the specifications the Engineer-In-Charge which shall prevail.

3. The Bidder (s) is/are to set out the whole of the works in conjunction with an officer to be deputed by the Engineer-in-charge and during the progress of the works, to amend on the requisition of the Engineer-in-charge any errors that may arise therein and provide all the necessary labours, and materials for so doing. The Bidder(s) is/are to provide all plant, labour and materials (with the exceptions noted in the schedule attached) which may be necessary and requisite for the works. All the materials and workmanship are to be the best of their respective kinds. The Bidder(s) is/are to leave the works in all aspects clean and perfect at the completion thereof.
4. The Bidder must extensively coordinate with FSCL and its Technical Consultant during all stage of the contract. The successful bidder shall obtain written approvals from FSCL at all stages, before commencing work on any particular stage of work. During the construction phase, after completion of any particular stage/phase of works and before commencing work on the next stage/phase of work, the successful bidder shall obtain written approval on the completed works/phase from FSCL, before commencing work on the next stage/phase of works
5. **CONTRACTOR TO SUPPLY PLANT, LADDERS, SCAFFOLDING, ETC.:** The contractor shall supply at his own cost materials (except such special materials if any, as may in accordance with the contractor be supplied from the Engineer – in – charge’s Stores) plants, tool, appliances, implements, ladders, cordage, tackle, Scaffolding and temporary work requisite for the proper execution the work whether original, or altered or substituted, and whether included in the specification or other documents forming part of the contract referred to in these condition or not or which may be necessary for the purpose of satisfying or complying with the requirement of the Engineer – in – charge as to any matter as to which under these conditions he is entitled to be satisfied, or which he is entitled to require together with carriage there for to and from the work . The contractor shall also supply without charge requisite number of persons with the means and materials necessary for the purpose of setting out works, and counting, weighing & assisting in the measurement or examination at any time and from time to time of the work, or materials. Failing his so doing the same may be provided by the Engineer -in charge at the expenses of the contractor and the expenses may be deducted from any money due to the contractor under the contract, or from his security deposit or the proceeds of sale thereof, or of a sufficient portion thereof.
6. During the entire contract period (Construction and Operation and Maintenance); the Contractor is liable for damages arising from non-provision of lights fencing etc. The contractor shall also provide at his own cost except when the contract specifically provides otherwise and except for payments due under clause all necessary fencing and lights required to protect the public from accident and shall be bound to bear the expenses of defense of every suit, action or proceedings at law that may be brought by any person for injury sustained owing to neglect of the above precautions & to pay any damage and costs which may be awarded in any such suit, action or proceedings to any such person or which may with the consent of the contractor be paid to compromise any claim by any such person.
7. The location of the existing features is provided for bidding purpose only. It is the responsibility of the bidder to gather relevant approved drawings and approvals from the concerned department and agencies, prior taking up the works defined in the scope of services of this tender.
8. If the contractor finds that the data provided to him is not accurate or require more information, in such cases the contractor shall conduct all relevant survey’s, studies, investigations at his own cost.

9. Prior bidding the project, the contractors shall visit the site and have his own assessment of the accuracy of the information provided in this document.
10. The contractor should submit the construction plan and have it approved by FSCL before starting of work including shifting of utilities.
11. The Contractor shall have approvals including design mix concrete from FSCL prior to the commencement of the tasks/activities.
12. **Drawings:** All the Drawings received from FSCL for construction work has to be returned to FSCL after completion of work.
13. All machine and equipment foundation design shall be as per the Manufacture. Prior commencing the works, the Manufacturer's design details shall be submitted to FSCL for approval.
14. **Electrical Works:**
 - a) The Supply, Construction, Testing and Commissioning, Operation and Maintenance of the electrical works indicated in the scope of works shall be under the supervision of the Dakshin Haryana Bijli Vitran Nigam (DHBVN).
 - b) Regardless of the reasons for the fault, the bidder shall rectify the fault in coordination with the DHBVN staff immediately.
 - c) With the exception for the items covered in the Defect Liability Period, the payment for both Construction and Operation and Maintenance period of five years (05) shall be done by the FSCL to the Bidder.
 - d) Before starting the Electrical works, the contractor shall take relevant approval from DHBVN. However the payment to all administrative/ supervision charge shall be made by FSCL to DHBVN.
 - e) FSCL shall provide the source for the power. The bidder shall at his own cost make all arrangement to supply power to its Equipment(s)/Tools (if required) which shall be used for construction and O & M purpose only. The cost shall include all metering connection, cable and necessary accessories etc.
 - f) At no point of time the contractor shall deny the instruction of FSCL/DHBVN during execution and O&M period.
 - g) There is a MOU signed between FSCL & DHBVN about Electrical works indicated in the scope of work.
15. All works indicated in the scope of Services of this tender (Backfilling, Concreting, steel work, civil works, Utility shifting, utility laying, landscaping, Electrical work, etc) Quality, Testing, Sampling, shall be done in accordance with BIS and specifications.
16. The contractor has to liaison with the various departments for seeking approvals including dismantling and shifting of existing utilities. The Administration cost shall be borne by the FSCL.
17. Utilities: The cost of shifting of the utilities like OFC and Gas shall borne by the relevant service provider.
18. Dismantling:
 - a. Prior to commencing dismantling work, the contractor shall discuss the dismantling plan and have it approved.
 - b. The dismantling plan shall clearly indicate the materials that would be reused or disposed.
 - c. The reusable materials shall be returned to the FSCL in such a way that it can be used again or sold.

- d. The reusable material shall be segregated and stacked at designated location as indicated by the Engineer-In-Charge.
 - e. In case the reusable material is damaged, the contractor will repay the cost of reusable material to FSCL. The decision of the E in C shall be final in assessing the damaged material.
19. All disposable (waste) material shall be disposed at place identified by the Engineer –In-Charge (E in C) or Construction & Debris (C & D) Plant in case of such notification issued by the relevant agencies.
 20. The contractor shall also ensure that the streets (beyond the site premises) on which his equipment traverses/ply are not damaged. If they are damaged or spread with construction material, the contractor shall restore it to the satisfaction of the E in C at his own cost.
 21. From the Commencement of the work to the completion of the contract, the site and the works thereupon are to be under the Bidder(s) charge. The Bidder (s) is/are to be held responsible for and to make good all injuries, damages and repairs occasioned or rendered necessary to the same by fire or other causes and they are to hold the FSCL harmless from any claims for injuries to persons or for structural damage to property happening from any neglect, default, want of proper care or misconduct on the part of the Bidder(s) or of any one in his/their employment during the execution of the works.
 22. The Bidder shall execute the work as per detailed specifications as incorporated in the tender document and in accordance with the approved drawings and special conditions incorporated in the tender documents or BIS.
 23. **Transport of materials is Bidder responsibility:** The Bidder shall make his own arrangement for transport of all materials. FSCL is not bound to arrange for priorities for getting wagons or any other materials though all possible assistance by way of recommendation will be given, if it is found necessary in the opinion of the Engineer–in–Charge. If the efforts of the Engineer-in charge prove ineffective, the Bidder shall have no claim for any compensation on this account.
 24. Contractor should submit the procurement plan prior to procuring the material and same should be approved by FSCL before procurement. If any materials whose make is not specified in the approved make list, then before procurement of same it is to be approved by FSCL.
 25. Contractor shall submit the monthly progress report and expedite the Project as per the instruction provided by the FSCL.
 26. Debris cleaning in the work area /site has to be done by contractor at their own cost. The debris needs to be disposed at the designated place as instructed by E in C.
 27. FSCL shall **NOT** provide any space or place for storage of construction materials or Equipment(s). The bidder shall arrange the same at their own cost.
 28. The contractor has to stack the excavated, debris and vegetation material at a location designated by the Engineer In Charge (E in C- FSCL official) at his own cost.
 29. The works shall be undertaken in a phased manner so that operation of Road and existing traffic should not get disturbed.
 30. The Bidder is to set out the whole of the works in conjunction with an officer to be deputed by the Engineer-in-charge and during the progress of the works, to amend on the requisition of the Engineer-in-charge any errors which may arise therein and provide all the necessary labours, and materials for so doing. The Bidder(s) is/are to provide all plant, labour and materials (with the exceptions noted in the schedule attached) which may be necessary and requisite for the works. All the materials and workmanship are to be the best of their respective kinds. The Bidder(s) is/are to leave the works in all aspects clean and perfect at the completion thereof.
 31. **COMPLETION TIME :**

- a) The works are to be commenced immediately upon receipt of order of commencement given in writing by the Engineer-in-charge. The whole work, including all such addition and variations as aforesaid (but excluding such, if any, as may have been postponed by an order from the Engineer-in charge) shall be completed in every respect within **24 (Twenty Four)** months including rainy season from the reckoned date. The work shall throughout the stipulated period of contract be proceeded with all due diligence, keeping in view that time is the essence of the contract.

32. CHANGE IN SCOPE :

- (i) As a part of the approval process, the bidder shall, when the Authority [The FSCL] demands changes, the bidder shall obtain the written approval before commencing the work for such changes. All such revisions shall be to the complete satisfaction of FSCL and on which mandatory written approvals obtained from the FSCL before commencing work related to the requested approval. No work under the scope of works under this bid/contract shall be commenced before obtaining the said written approval from the Authority.
- (ii) If at any time before or after the commencement of the work, Engineer-in-charge shall for any reason whatsoever: -
- (a) Cause alterations, omissions or variations in the drawings and specifications involving any curtailment of works as originally contemplated; or
- (b) Not requiring the whole of the work as specified in the tender to be carried out, The Bidder(s) shall have no claim to any payment or compensation whatsoever on account of any profit or advantage which he/they might have derived from the execution of the work in full as specified in the tender but which he/they did not derive in consequence of the curtailment of the works by reasons of alterations, omissions or variations or in consequence of the full amount of the work not having been carried out. But the Bidder(s) shall be entitled to compensation for any loss sustained by him/them by reason of his/their having purchased or procured any materials or entered in to any engagements or made any advance to labour or taken any other preliminary or incidental measures on account of or with a view to the execution of the works or the performance of the contract.
- (iii) In case any item/work is not executed as per the drawings, designs, estimates and /or specifications (as per the agreement executed) the same shall be deducted and recovered from the Bidder at (prevailing market rates or at par with FSCL/ HSR whichever is more at the time of execution in force Plus 15 % of total value as extra. No compensation shall be paid for any change in quantities occurring due to site and / or requirements of design.
- (iv) **Addition Alterations In Specifications & Designs:** The Chief Executive Officer shall have power to make any alteration in, omissions, from additions to, or substitutions for, the original specifications, drawings & instructions that may appear to him to be necessary or advisable during the progress of the works, and the contractor shall bound to carry out the work in accordance with any instructions which may be given to him to writing signed by the Engineer in Charge such alternations omissions additions or substitutions shall not invalidate the contract and any altered, additional of substituted work which the contractor may be directed to do in the manner above specified as part of the work shall be carried out contractor on the same conditions in all respects on which he agree to do the main work & at the same rates as are specified in the tender for the main work, provided total value of such increased or altered or substituted work does not exceed 25% of the amount put on tender inclusive of contractor's percentage. If such value exceeds 25%, it shall be open to the contractor either to determine the contract or apply for extension.

33. BILL OF QUANTITIES

- (i) The Bill of Quantities shall contain items for the construction, installation, testing, and commissioning works to be done by the Contractor.
- (ii) The Bill of Quantities is used to calculate the Contract Price. The Contractor is paid for the quantity of the work done at the rates in the Bill of Quantities for each item

34. CHANGE IN QUANTITIES

(i) If the final quantity of the work done differs from the quantity in the Bill of Quantities for the particular item by more than 25 per cent provided the change exceeds 1% of initial Contract Price, the Engineer shall

adjust the rate to allow for the change, duly considering

- (a) justification for rate adjustment as furnished by the contractor,
- (b) economies resulting from increase in quantities by way of reduced plant, equipment and overhead costs,
- (c) entitlement of the contractor to compensation events where such events are caused by any additional work

The Engineer shall not adjust rates from changes in quantities if thereby the Initial Contract Price is exceeded by more than 15 per cent, except with the Prior approval of the Employer. If requested by the Engineer, the Contractor shall provide the Engineer with a detailed cost breakdown of any rate in the Bill of Quantities

35. PAYMENT FOR CHANGE IN QUANTITIES

(i) The Contractor shall provide the Engineer with a quotation (with breakdown of unit rates) for carrying out the Variation when requested to do so by the Engineer. The Engineer shall assess the quotation, which shall be given within seven days of the request or within any longer period stated by the Engineer and before the Variation is ordered.

(ii) If the work in the Variation corresponds with an item description in the Bill of Quantities and if, in the opinion of the Engineer, the quantity of work is above the limit stated in Sub Clause 35 (i) or the timing of its execution do not cause the cost per unit of quantity to change, the rate in the Bill of Quantities shall be used to

calculate the value of the Variation. If the cost per unit of quantity changes, or if the nature or timing of the work

in the Variation does not correspond with items in the Bill of Quantities, the quotation by the Contractor shall be

in the form of new rates for the relevant items of work.

(iii) If the Contractor's quotation is unreasonable, the Engineer may order the Variation and make a change

to the Contract Price which shall be based on Engineer's own forecast of the effects of the Variation on the Contractor's costs

(iv) If the Engineer decides that the urgency of varying the work would prevent a quotation being given and

considered without delaying the work, no quotation shall be given and the Variation shall be treated as a Compensation Event.

(v) The Contractor shall not be entitled to additional payment for costs which could have been avoided by giving early warning

36. DAMAGES TO THE EXISTING INFRASTRUCTURE:

- a) During the contract period (Construction and Operation and Maintenance), the bidder shall be responsible for any damage caused to existing infrastructure like, trees, sewerage line, water pipelines, telephone lines, OFC cables, Gas lines or any utility lines etc. Upon request from FSCL or by himself, the bidder shall restore the damaged works immediately at his own cost to the satisfaction of the FSCL.
- b) During the Construction and O& M period, in case the bidder fails to repair the damages caused to existing infrastructure indicated in the above clause, the E in C shall have the damages repaired by other contractor or its staff or by any other means and deduct the actual amount incurred as per market rate plus 15 % extra for undertaking such works from the contractors bills. The delays caused due to inaction of the bidder on the above damages will be considered for penalty equivalent to the sum indicated in the “Penalty clause” in the GCC of this document.
- c) The contractor will inform in writing if any Heritage Structure/Tree is found in the work area. After receipt of written confirmation or instruction from FSCL the contractor will take suitable action.
- d) In case of shifting or cutting of trees, prior permission has to obtain in writing from FSCL and all other relevant authorities. If the tree is cutted then it shall be the property of FSCL . The contractor shall deposit the same at the designated place shown by Engineer-In-Charge.
- e) If any utilities lines which are affecting the construction of Road then contractor shall inform in writing to FSCL. As per the instructions of E in C the contractor will shift the lines accordingly at their own cost.

37. OBLIGATION OF EMPLOYER :

- (i) Upon request from the contractor, whatever relevant data available with the FSCL will be shared with the contractor.
- (ii) All the approved construction drawings shall be provided by FSCL. No work shall be started without approved construction drawings.
- (iii) Acquisition of land or removal of encroachment in the work area shall be the responsibility of FSCL. The bidder/contractor shall mobilize their team only after getting the clearance from FSCL.

38. EXECUTION OF WORK ACCORDING TO TIME SCHEDULE:

The work shall be done by the Bidder according to the time schedule (working hours, weekdays etc) fixed by the Engineer-In-Charge, FSCL. Work schedule should be planned in such a way that the operation of existing establishment like schools, hospitals, shopping malls, shops etc should not get affected. The inconvenience to the commutator passing through this road should be minimum due to this construction. In case of any complaints, the contractor shall inform the FSCL and as per instruction shall cease the works until further instructions from FSCL

39. DESIGN AND CONSTRUCTION :

- (i) The Bidder (s) cannot vary or deviate from the drawings or specifications or execute any extra work of any kind whatsoever unless upon the authority of Engineer-in-charge to be sufficiently shown by any order in writing by any plan or drawings expressly given and signed by him as extra or variation or by any subsequent written approval signed by him.
- (ii) In cases of daily labor all vouchers for the same are to be delivered to the Engineer-in-charge or the officers-in-charge at least during the week following that in which the workmen have been engaged and only such day work is to be allowed for as such as may have been authorized by the

Engineer-in-charge to be so done unless the work cannot from its character be properly measured and valued.

(iii) **Applicable Specifications:** As indicated in the Tender document, I.S.I. codes for buildings or special specifications whenever enclosed separately shall apply in the case of any variance the following order of precedence shall prevail.

a) Specifications as per NIT.

b) Specifications as per S.O.R.

c) MORTH/IRC specifications for road.

d) Mode of measurements of work shall be as provided in the S.O.R. applicable to the contract. Where such mode of measurement is not specified in the S.O.R. it shall be done as per I.S.I. Code of building measurement. However if any mode of measurement is specifically mentioned in the N.I.T. (Tender-document) the same will get precedence over all the above.

(iv) **WORK TO BE EXECUTED IN ACCORDANCE WITH SPECIFICATION, DRAWING, ORDER, ETC.:** The contractor shall execute the whole and every part of work in the most substantial and workman like manner, and both as regards materials and otherwise in every respect in strict accordance with the specifications. The contractor shall also conform exactly fully and faithfully to the designs, drawings and instructions in writing relating to the work signed by the Engineer – in – charge and lodged in his office and to which the contractor shall be entitled to have access at such office or on the site of the work for the purpose of inspection during office hours and the contractor shall if he so requires be entitled at his own expense to take or cause to be made copies of the specifications, and of all such designs, drawings and instructions as aforesaid.

(v) In the case of any class of work for which there is no specification as is mentioned in Rule such work shall be carried out in accordance with the specification approved by CEO, FSCL for application to work.

(vi) The Engineer-in-charge has full power to require the removal from the premises of all materials which, in his opinion, are not in accordance with the specification and in case of default, the Engineer-in-charge is to be at liberty to employ other persons to remove the same without being answerable or accountable for any loss or damage that may happen or arise to such materials. The Engineer-in-charge is also to have full power to substitute other improper materials to be substituted and in case of default, the Engineer-in-charge may cause the same to be supplied and all costs which may arise due to such removal and substitution are to be borne by the Bidder (s).

40. QUALITY ASSURANCE, MONITORING AND SUPERVISION :

(i) The Engineer-in-charge is to have at all times access to the works which are to be entirely under his control. He may require the Bidder(s) to dismiss any person in the Bidder (s) employ upon the works that may be incompetent or misconduct him and the Bidder (s) is/are forthwith to comply with such requirements.

(ii) Cubes shall be casted and tested for all concrete pour as per the relevant IS Standards.

(iii) Contractor shall submit mock samples and product literature of all materials (Material used in construction of Smart Road) & it have to be approved by FSCL before procuring the materials.

(iv) All the materials have to be tested & necessary reports/ test certificated has to be submitted to FSCL before start of work.

(v) The cost of conducting all the tests which is required during the execution of contract or as instructed by E in C shall be borne by the contractor. All the required test has to be carried as per

relevant IS Standard.

- (vi) The Contractor has to strictly adhere to the instructions provided by the FSCL officials from time to time. The contractor shall rectify bad workmanship works within the stipulated time provided by the E in C. The E in C has the right to dismantle the works which according to him is not complying with the drawings and standards. The Contractor upon receiving such instruction shall either rectify the defect or dismantle the structure at his own cost.
- (vii) The bidder has to arrange accredited 3rd party testing agency to meet the quality standard at his own cost. The frequency of Testing shall be as per the BIS or as indicated by the E in C.
- (viii) The E in C has the right to reject the concrete or all other works that according to him is not complying the standards and specifications. The contractor upon receiving such instruction with no time shall stop concreting and discard the concrete at his own cost.
- (ix) At any point of the contract period, In case the contractor does not obey the instructions of the E in C, the E In C has the authority to get the work/dismantled/ rectified by other contractors/workers. The cost of such work on actual amount incurred as per market rate plus 15 % extra amount will be deducted from the contractor's bill.
- (x) **Inspection and Technical audit by the Authority :** The FSCL shall have the right to cause Audit and Technical Examination of the work and the final bills of the Bidder including all supporting voucher, abstract, etc. to be made as per payment of the final bill and if as a result of such Audit and Technical Examination the sum is found to have been overpaid in respect of any work done by the Bidder under contract or not to have been executed, the Bidder shall be liable for refund of the amount of over payment and it shall be lawful for the FSCL to recover the same from the security deposit of the Bidder or from any other dues payable to the Bidder. If it is found that the Bidder was paid lesser than what was due to him under the contract the amount of such under payment shall be duly paid by the FSCL, to the Bidder. In the case of any audit examination and recovery consequent on the same, the Bidder shall be given an opportunity to explain his case and the decision of the Chief Executive Officer- FSCL shall be final. In the case of Technical Audit, consequent on which there is a recovery from the Bidder no recovery should be made without orders of the Chief Executive Officer- FSCL whose decision shall be final. All action(s) under this clause should be initiated and intimated to the Bidder within a period of Twelve months from the date of completion.
- (xi) **Work to be open for inspection-contractor or responsible agent to be present:** All work under or in course of execution or executed in pursuance of the contract shall at all time be open to the inspection and supervision of the Engineer-in-Charge and his subordinates and the contractor shall at all time during the usual working hours, and at all other times at which reasonable notice of the intention of the Engineer-in-charge or his subordinate to visit the work shall have been given to the contractor, either himself be present to receive orders and instruction or have a responsible agent duly accredited in writing present for that purpose. Orders given to the contractor's agent shall be considered to have the same force as if they had been given to the contractor himself.
- (xii) Further, the Contractor shall ensure of having a knowledgeable Technical Engineer at site all times. The Engineer will be responsible for coordinating with the FSCL officials and his firm. The Contractor shall replace the Technical Staff if he/she is found to incompetent by the FSCL officials.
- (xiii) All works to be executed under the contract shall be executed under the direction and subject to the approval in all respect of the CEO, FSCL for the time being who shall be entitled to direct at what point or points and in what manner they are to commenced and from time to time carried on.
- (xiv) Contractor should provide a Quality Assurance Plan (QAP) and have it approved by the FSCL

.The cost of all material inspection within and outside the site shall be borne by the contractor. This includes cost of travel and accommodation of FSCL officials/Consultants for inspection outside the Site Premises.

- (xv) FSCL reserve the rights to reject any materials which contractor shall procure without prior approval from FSCL. The cost of such rejected materials shall be bourn by Contractor

41. INSURANCE :

(i) The Contractor shall provide, in the joint names of the Employer and the Contractor, insurance cover from the Start Date to the end of the Defects Liability Period.for the following events which are due to the Contractor/s risks:

a)loss of or damage to the Works, Plant and Materials;

b) loss of or damage to Equipment;

c)loss of or damage of property (except the Works, Plant, Materials and Equipment) in connection with the Contract; and

d) Personal injury or death.

e)The minimum insurance cover for physical property, injury and death is Rs.5.00 Lacs per occurrence with the number of occurrences limited to four. After each occurrence, Contractor will pay additional premium necessary to make insurance valid for four occurrences always.

(ii) Policies and certificates for insurance shall be delivered by the Contractor to the Engineer for the Engineer's approval before the Start Date. All such insurance shall provide for compensation to be payable in the types and proportions of currencies required to rectify the loss or damage incurred.

(iii) If the Contractor does not provide any of the policies and certificates required, the Employer may effect the insurance which the Contractor should have provided and recover the premiums the Employer has paid from payments otherwise due to the Contractor or, if no payment is due, the payment of the premiums shall be a debt due

(iv) If the Contractor shall fail to effect and keep in force any of the insurances referred to in or any other insurance which he may be required to effect under the terms of the Contract, the Employer may in any such case effect and keep in force any such insurance and pay such premium as may be necessary for that purpose and from time to time deduct the amount so paid by the Employer as aforesaid from any monies due or which may become due to the Contractor, or recover the same as a debt due from the Contractor

(v) Alterations to the terms of insurance shall not be made without the approval of the Employer.Both parties shall comply with any conditions of the insurance policies.

42. DEFECTS LIABILITY PERIOD: The contractor shall be responsible for all the defects except usual wear and tear of this project for the period of two years from the date of issue of Completion certificate.

43. COST OF REMEDYING DEFECTS :

(i) At any point of the contract period, If in the opinion of the Engineer-in-charge any of the works, are executed with improper/Inferior materials or defective workmanship, the Bidder(s) is/are, when required by the Engineer-in-charge to re-execute the same forthwith and to substitute proper materials and workmanship, and in case of default of the Bidder(s) in doing so within a week, the Engineer-in-charge shall have full powers to employ other persons/agency to re-execute the work and the cost there of the actual amount incurred as per market rate plus 15 % extra amount shall be borne by the Bidder(s).

- (ii) Any Defects, defects in bituminous layers like pot holes, rutting, cracks, leakage in utility lines, or other faults which may appear within the contract period arising out of defective or improper materials or workmanship or due to any other reason are, upon the direction of the Engineer-in-charge, to be amended and made good by the Bidder at his / their own cost unless the Engineer-in-charge decides that he/they ought to be paid for the same and in case of default the Engineer-in-charge may recover from the Bidder (s) the cost of making good the works as per prevailing norms and specifications.

44. PENALTY CLAUSE FOR DELAY IN COMPLETION :

The Engineer-In-Charge have full power to recover penalty for Delay Period during both construction and operation and maintenance. The Penalty will be calculated @ 0.5% Per Week or Part thereof of value of works not completed. Total Penalty shall be limited to maximum to 5% of Agreement Amount for construction period and 5 % of amount of the operation and maintenance for the O & M period. Engineer-In-Charge will be fully responsible for recovery of Penalty. The timeline for completion and delays of maintenance shall be determined by the E In C.

45. TERMINATION :

- (i) The Engineer-in-charge may terminate the contract if the Bidder causes a fundamental breach of the contract.. The fundamental breach of contract shall include, but not be limited to, the following: -
 - a) The Bidder stops work for four weeks, when no stoppage of work is shown on the current programme or the stoppage has not been authorized as by the Engineer-in-charge.
 - b) If serious rectification of bad / poor quality work is not done by the Bidder within 15 days from 1st notice issued to him by Engineer-in-charge might attract termination of the agreement and whole performance guarantee will be forfeited.
 - c) If the Bidder fails to appoint the technical staff and if appointed do not function properly for 4 weeks even after due written notice by the Engineer-in charge.
 - d) If he violates labour laws.
 - e) Any other deficiency which goes to the root of the contract Performance
- (ii) If the contract is terminated, the Bidder shall stop work immediately, make the site safe and secure and leave the site as soon as reasonably possible.
- (iii) The Engineer - in - charge shall cause recording and checking of measurements of all items of work done (taking in to account quality and quantity of items actually executed) and prepare the final bill after adjusting all previous outstanding dues. Such recording of measurements shall be done after due notice regarding time and date of recording measurement and directing the Bidder to either remain present himself or his authorized representative so as to satisfy himself that the recording of measurement is just and proper. Failure on his parts either to attend and or refusing to acknowledge the measurement so recorded in the department measurement book, shall be at his sole risk and responsibility.
- (iv) **Payment upon Termination :**
 - (a) If the Contract is terminated because of a fundamental breach of Contract by the Contractor, the Engineer shall issue a certificate for the value of the work done less advance payments received upto the date of the issue of the certificate, less other recoveries due in terms of the contract, less taxes due to be deducted at source as per applicable law and less the cost of the work not completed plus 15% of actual cost incurred. Additional Liquidated Damages shall not apply. If the total amount due to the Employer exceeds any payment due to the Contractor the difference shall be a debt payable to the Employer. The Employer shall also be free to recover the amount

from any other due payments to the contractor against this contract.

- (b) If the Contract is terminated at the Employer's convenience or because of a fundamental breach of Contract by the Employer, the Engineer shall issue a certificate for the value of the work done, the cost of balance material brought by the Contractor and available at site, the reasonable cost of removal of Equipment, repatriation of the Contractor's personnel employed solely on the Works, and the Contractor's costs of protecting and securing the Works and less advance payments received up to the date of the certificate, less other recoveries due in terms of the contract and less taxes due to be deducted at source as per applicable law

46. SUBMISSION OF BILL :

- (i) **Bill To Be Submitted Monthly:** "A bill shall be submitted by the contractor by 3rd day of each month for all works executed by him till the end of previous month less the gross amount received by him till the last previous month. This bill must be supported by records of detail measurement of quantities of all executed item of work along with true copies of record and result of all test conducted in the previous month (date wise). The C.E.O shall take or cause to be taken the requisite measurement for purpose of having the same verified/checked by the his authorized Engineer/Representative concern (if any) for quantity, quality and specification and examining all the "test results" and record the same in the Departmental measurement book. Based on above record measurement bill shall be corrected /prepared afresh. The contractor shall sign the measurement and the bill.

If the contractor fails to submit, the bill on or before the day prescribed, the Engineer in Charge after waiting for another 15 days shall depute a subordinate to measure the said work in the presence of contractor and or his authorized Engineer/Representative, whose counter signature to the measurement recorded with quantity and quality remark will be sufficient proof for acceptance of the same and shall be binding on the contractor.

All such running bill payments are by way of "Advances" and shall be subject to final adjustment.

Bills to be submitted for Maintenance: The Bidder shall submit the maintenance running bill every three months (quarter). The bill amount would be the amount quoted by the bidder for that year and interpolated for the quarter.

Payment for the O & M shall be made upon issue of satisfactory completion certificate for that period by the E in C.

- (ii) **Bill To Be On Printed Forms:** The contractor shall submit all bills on printed forms to FSCL account, and the charges in the bills shall always be entered at the rates specified in the tender or in the case of any extra work ordered in pursuance of these conditions, and not mentioned or provided for in the tender at the rates hereinafter provided for such work. The deduction or addition as the case may be of the percentage will be calculated on the amount of the bill for the work done, after deducting the cost of materials supplied departmentally at rates specified in the agreement.

47. PAYMENT :

- (i) The Bidder(s) shall be paid as per the payment schedule.
- (ii) A certificate of the Engineer - in - charge or Authorised person by FSCL as the case may be, showing the final balance due or payable for the Bidder(s) is to be conclusive evidence of the works / having been duly completed and that the Bidder(s) is/are entitled to receive payment of the final balance but without prejudice to the liability of the Bidder(s) under provisions of clause.
- (iii) **Mobilization Advance :** An interest bearing mobilization advance up to the extent of 5% of contract

value against unconditional and irrecoverable bank guarantees of 110% of mobilization Advance to be furnished by the contractor. Interest @Prime Lending Rate (PLR) of SBI prevalent at the time of tender per annum shall be charged against the mobilization advance given to the contractor. The recovery of the mobilization advance together with interest shall be done through percentage deductions from interim/running payments, in the manner prescribed in the contract. It shall be desirable to recover the total amount of mobilization advance alongwith interest within 80% of the time stipulated for completion. The mobilization bank guarantee shall be released after the recovery of full mobilization advance, including interest thereon. In case, of slow progress of work, the Engineer-In-Charge comes to a conclusion that the total amount of mobilization advance with interest cannot be recovered by the time 80% of stipulated time is over, the bank guarantee(s) furnished by the contractor may be encashed . The Mobilization advance shall be paid after agreement is signed and upon submission of performance security bank guarantee of specified value.

- (iv) **Bank Commission Charges:** Bank commission charges in all payments by demand drafts shall be borne by Bidder.
- (v) **Payment Of Intermediate Certificate To Be Regarded As Advances:** Intermediate payment during the course of execution of works if considered desirable in the interest of work, can be made on monthly basis, on the recommendation of Engineer In charge, in such a way that in his opinion, it reflects the amounts due to the Contractor in accordance with the contract, after deduction of any sums which may have become due and payable by the contractor to the employer. In cases where there is a difference of opinion as to the value of any item, the Engineer's view shall prevail. Within the 14th day of the receipt of the monthly bill, the Engineer shall determine the amounts due to the contractor and shall deliver to the Employer and the contractor an Interim Payment Certificate, certifying the amounts due to the contractor.
- (vi) But all such intermediate payments shall be regarded as payments by way of advance against the final payment for works actually done and completed and shall not preclude the requiring of bad unsound and imperfect or unskillful work to be removed and taken away and reconstructed or erected or be considered as admission of the due performance of the contract or any such part thereof, in any respect, or the accruing of any claim, nor shall it conclude determine, or affect in any way the powers of the employer under these conditions or any of them as to the final settlement and adjustment of the accounts or otherwise or in any other way vary or affect the contract. The final bill shall be submitted by the contractor within one month of the date fixed for completion of the work; otherwise the Engineer-in charge's certificate of the measurement and of the total amount payable for work accordingly shall be final and binding on all parties.
- (vii) Receipts for payments made on account of a work when executed by a firm must also be signed by the several partners, except where the contractors are described in their tender as a firm/ proprietor in which case the receipt must be signed in the name of-the firm by one of the partners, or by some other person having authority to give effectual receipt for the firm.

48. ARBITRATION CLAUSE:

Except as otherwise provided in this contract all question and dispute relating to the meaning of the specification, designs, drawings and instruction herein before mentioned as to thing whatsoever in any way arising out of or relating to the contract designs, drawings, specification, estimate, concerning the works, or the execution or failure to execute the same, whether arising during the progress of the work, or a after the abandonment there of shall be referred to the TA -FSCL for his/her decision, within a period of 30 (thirty) days of such an occurrence (s). There upon the TA-FSCL shall give his written instructions and/or decisions, after hearing the contractor and Engineer in Charge within a period of 15 (fifteen) days of such request. This period can be extended by mutual consent of parties. Upon

receipt of written instructions or decisions, of TA -FSCL the parties shall promptly proceed without delay to comply such instructions or decisions. If the TA-FSCL fails to give his instruction or decisions in writing within a period of 15 (fifteen) days or mutually agreed time after being requested and/or, if the party (es) is/are aggrieved against the decision of TA-FSCL, the aggrieved party may within 30 days prefer an appeal to the Chief Executive Officer -FSCL, who shall afford an opportunity to the parties of being heard and to offer evidence in support of his appeal. The, Chief Executive Officer, will give his decision within 30 (thirty) days, or such, mutually agreed period. If any party is not satisfied with the decision of the Chief Executive Officer, he can , he can request for an arbitration for resolving the dispute as per THE ARBITRATION AND CONCILIATION ACT, 1996 and THE ARBITRATION AND CONCILIATION (AMENDMENT) ACT, 2015 A reference to Arbitration Tribunal shall be no ground for not continuing the work on the part of the Contractor. Payment as per original terms and condition of the agreement shall be continued by the Engineer in Charge.

- 49. DEATH OR PERMANENT INVALIDITY OF BIDDER:** - if the Bidder is an individual or a proprietary concern or a partnership concern, dies during the currency of the contract or becomes permanently incapacitated, and where the surviving partners are only minors, the contract shall be closed without levying any damages/ compensation as provided in the contract agreement. However, if competent authority is satisfied about the competence of the surviving Partner[s], then the competent authority Engineer - in - charge shall enter into a fresh agreement for the remaining work strictly on the same terms and condition under which the contract was awarded.
- 50.** FSCL reserves the right to accept or reject any Tenders or all tender at any time prior to the Award of Contract, without thereby incurring any liability to the affected Bidder or Bidders or any obligation to inform the affected Bidder or Bidders of the grounds for the FSCL action.

51. SUBLETTING OF WORKS:

The contract may be rescinded & security deposit forfeited, for subletting, bribing or if contractor become insolvent.

The contract shall not be assigned or sublet without the written approval of the Engineer in Charge, & if the contractor shall assign or sublet his contract, or attempt, so to do, or become insolvent commence any insolvency proceeding for make any composition with his creditors, or attempt so to do or if any bribe, gratuity, gift, loan, perquisite , regard of advantage pecuniary or otherwise shall either directly or indirectly be given, promised or offered by the contractor, or any of his servants, or agents to any public office or person in the employ of Authority in any way relating to his office or employment, or if any such officer or person shall become in any way directly or indirectly interested in shall contract, the Engineer in Charge may there up by notice in writing record the contract, & the S.D. of the contractor shall be there upon stand forfeited & be absolutely at the disposal of Authority, & the same consequence shall ensure as if the contract had been rescinded under clause 6 hereof , & in addition the contract shall not be entitled to recovered or be paid for any work there to fore actually per firmed under the contract.

If the contractor gets item/items of work accepted on a task rate basis with or without materials, this shall not amount to sub-letting of the contract.

Sum payable by way for compensation to be considered as reasonable compensation without reference to actual loss.

All sums payable by way of compensation under any of these conditions shall be considered as reasonable compensation to be applied to the use of FSCL without reference to the actual loss or damage sustained, and whether or not any damage shall have been sustained.

52. TAXES, ROYALTY, ETC.:

[a] Taxes: The rate quoted by the Bidder shall include Goods and Service Tax component. The quoted rate shall therefore be including the Goods and Service Tax and other taxes such as sales and other levies, duties, royalties, cess, toll, taxes of Central and State Governments, local bodies and authorities that the Bidder will have to pay for the performance of this Contract. The FSCL will perform such duties in regard to the deduction of such taxes at source as per applicable law. Any payment claimed by the Bidder due to any change[s] in the existing tax structure shall not be entertained by the FSCL Deposit/remittance of Goods and Service Tax in government treasury within stipulated time shall be sole responsibility of the contractor and failing to which FSCL may recover the due amount from any other payable dues with FSCL. The decision of competent authority shall be final and binding on the contractor in this regard.

[b] Royalty on Minor Minerals: The Bidder shall pay all quarries, Royalty charges etc. If the Bidder fails to produce the royalty clearance certificate from concerned department then the Executive Engineer shall deduct the royalty charges from his bills and keep in deposit head, which shall be refunded to the Bidder on production of royalty clearance certificate from the concerned department. If he fails to produce the royalty clearance certificate within 30 days of submission of final bill, then royalty charges which were kept under deposit head by the Executive Engineer shall be deposited to the concerned department and his final bill payment shall be released.

In all cases where change[s] in the royalty rates of minor minerals are notified by the state government after the date of submission of financial offer by the bidder/ Bidder the same shall be not reimbursed.

[c] Income tax at the rate of 2% or such other percentage as may be fixed by income tax department from time to time from any sum payable to the Bidder shall, at the time of credit of such sum or at the time of payment to the Bidder by cash, cheque or draft or any other mode, shall be deducted at the source from the running, final or any type of payment for this contract as per section 194 of income tax Act. 1961.

[d] Labour Welfare Cess at the rate of 1% or such other percentage as may be fixed by Labour department Government of Haryana from time to time from any sum payable to the Bidder shall, at the time of credit of such sum or at the time of payment to the Bidder by cash / cheque or draft or any other mode, shall be deducted at the source from the running, final or any type of payment for this contract as per Labour Act.

[e] It is open to the Bidder, as the case may be; to make an application to the Income Tax officer concerned and obtain from him a certificate authorizing the payer to deduct tax at such lower rate or deduct no tax as may be appropriate to his case. Such certificate will be valid for the period specified therein unless it is cancelled by the income Tax Officer earlier.

53. MODEL RULES FOR WATER SUPPLY, SANITATION IN LABOUR CAMPS:

The Bidder will be bound to follow the Haryana model rules relating to layout of water supply and sanitation in labour camps (Vide Annexure-A).

54. FAIR WAGES TO LABOURERS:

The Bidder shall pay not less than minimum wages as described in the Labour Acts & Laws to labourers engaged by him on the work. (Copy of rules enclosed vide Annexure-B).

55. RIGHT TO TAKE UP WORK DEPARTMENTALLY OR TO AWARD ON CONTRACT:

The Chief Executive Officer, FSCL reserves the right to take up departmental work or to award works on contract in the vicinity without prejudice to the terms of contract.

56. ISSUE OF MATERIALS BY THE DEPARTMENT:

No Materials shall be supplied by the FSCL. So far as supply of cement and steel (TMT Bars) and other materials is concerned these has to be arranged by the Bidder himself at his own cost and the conditions given in the Annexure-E shall prevail.

57. REMOVAL OF UNSUITABLE OR UNDESIRABLE EMPLOYEES OF BIDDER:

The Bidder shall, on receipt of the requisition form the Engineer-in-charge at once remove any person employed by him on the work who in the opinion of Engineer-in-charge is unsuitable or undesirable.

58. RECOVERY OF AMOUNT BY FSCL FROM BIDDER:

Any amount due to FSCL from the Bidder on any account, concerning work may be recovered from him as arrear of land revenue and/or from payment due to him in any of the Govt. / Semi Government Department.

59. MISCELLANEOUS :

- (i) FSCL shall provide the source of water. The contractor has to make his own arrangement for distribution of water Like Hose Pipe, water tanker etc at their own cost.
- (ii) The Electric charges for running the construction equipment(s) during the contract including O & M period shall be bourn by contractor. FSCL shall provide only the source of Power. In case power failure, Contractor shall make alternate arrangement for supply of Power at their own cost.
- (iii) The bidder shall arrange at his own cost tools and plants required for proper execution of work during the Contract period which includes construction and operation and Maintenance period.
- (iv) The contractor should submit the Site Layout plan indicating the location of the Labour Camp, Store House, Site Laboratory if any etc and have it approved by FSCL.
- (v) All work materials brought and left upon the ground by the Bidder(s) or his/their orders for the purpose of forming part of the works are to be considered to be the property of the FSCL and the same are not to be removed or taken away by the Bidder's or any other person without the special license and consent in writing of the Engineer-in-charge but the FSCL is not to be in any way answerable for any loss or damage which may happen to or in respect of any such work or materials either by the same being lost or stolen or injured by weather or otherwise.
- (vi) From the Commencement of the work to the completion of the contract, the site there upon are to be under the Bidder(s) charge. The Bidder (s) is/are to be held responsible for and to make good all injuries, damages and repairs occasioned or rendered necessary to the same by fire or other causes and they are to hold the FSCL harmless from any claims for injuries to persons or for structural damage to property happening from any neglect, default, want of proper care or misconduct on the part of the Bidder(s) or of any one in his/their employment during the execution of the works.
- (vii) The Bidders is / are to provide everything of every sort and kind (with the exception noted in the schedule attached) which may be necessary and requisite for the due and proper execution of the several works included in the contract according to the true intent and meaning of the drawings and specifications taken together, which are to be signed by the Engineer in Charge, FSCL, (herein after called the Engineer-In-Charge) and the Bidder whether the same may not be particularly described in the specifications or shown on the drawings, provided that the same are reasonably and obviously to be inferred there from and in case of any discrepancy between the drawings and the specifications the Engineer-In-Charge which shall prevail.
- (viii) The authority competent to accept a tender reserves the right of accepting the tender for the whole work or for distinct part of it or of distributing the work between one or more Bidders.

- (ix) If the total duration of suspension of the work is more than the six months, then this suspension of the work will be considered as permanent stoppage of the work, and the contractor can determine the contract, if he so desires.
- 60. Increase or Decrease of work specified:** The competent authority reserves the right to increase or decrease any work specified within lump sum during the currency of the contract and Bidder will be bound to comply with the order of the competent authority.
- 61. Canvassing or support for acceptance of tender:** Canvassing or support in any form for the acceptance of any tender is strictly prohibited. Any Bidder doing so will render him liable to penalties which may include removal of his name from the register of approved Bidders.
- 62. List of persons employed by Bidder:** Bidder shall not be permitted to tender for works in the FSCL who's near relative is posted as Assistant Engineer or above capacity. A list showing the names of the persons who are working with the Bidder and are near relatives to any officer in the FSCL should also be appended to the tender. The Bidder should also intimate to the Engineer-In-Charge the names of subsequently employed persons who are near relatives of any officer in FSCL. Any breach of this condition by the Bidder would render him liable to be removed from the bidding process.
- 63. Validity of Offer:** Tenders shall remain open up to **180 days** from the prescribed date of opening of tenders. However, In the event of the Bidder withdrawing the offer before the aforesaid dates for any reason whatsoever, Earnest money deposited with the tender shall be forfeited.

In the event of Bidder withdrawing his/her offer before the expiry of the period of validity of offer or failing to execute the contract agreement he/she not be entitled to tender for this work in the case of recall of tenders in addition to forfeiture of his/her earnest money as may be applicable for the work. If the Bidder has committed a similar default on an earlier occasion as well, his/her registration in the department may be suspended temporarily for a period of 6 months from such date as may be ordered by the authority which had registered him/her.

- 64. FORCE MAJEURE:** Should failure in performance of any part of this contract arise from war, insurrection, restraint imposed by FSCL, act of Legislature or other authority, stoppage of hindrance in the supply of raw materials, or fuel, explosion, accident, strike, riot, lockout, or other disorganization, of labour or transport, breakdown of machine, flood, fire act of God, or any inevitable or unforeseen event beyond human control directly or indirectly interfering with the supply of stores or from any cause which may be a reasonable ground for an extension of time, the competent authority will allow such additional time as he considers to be justified in the circumstances of the case. No compensation will be payable to the Bidder for any loss incurred by him due to these reasons.
- 65.** Each Bidder shall supply the name, residence and place of business of the person or persons submitting the tender and shall be signed by the Bidder with his usual signature. When tender is submitted by partnerships the full names of all partners shall be furnished. An attested copy of the constitution of the firm and the registration number of the firm shall be furnished. In such a case, the tender must be signed separately by each partner thereof or in the event of the absence of any partner it must signed on his behalf by a person holding a power of attorney authorizing him to do so. Tenders by a company /corporation shall be signed with the legal name of the company/corporation followed by the name of the state of incorporation and by signature and by designation of the president, secretary or other persons authorized to bind it in the matter.
- 66. TECHNICAL KNOWLEDGE AND STAFF:** The tender shall be submitted with an Information that the Bidder has successfully carried out similar works of this nature and has adequate organization, machinery and experienced personnel to handle jobs of this type and magnitude.

67. A brief description of similar works previously executed by Bidder: After the tender has been opened any Bidder may be required to submit detailed particulars of such works along with manner of their execution and any other information that will satisfy the officer receiving the tender that the Bidder has adequate organization, including experienced personnel to execute vigorously the work to be carried out as per these specifications.

(a) The Bidder shall employ adequate Construction Managers, Graduate Engineers & Diploma Engineers as Technical Staff during the execution of the work.

(b) The Technical Staff should be available at site and take instructions from the Engineer-in-Charge or other supervisory staff including PMC.

(c) In case the Bidder fails to employ the technical staff as aforesaid, the Engineer-In-Charge shall have the right to take suitable remedial measures.

(d) The Bidder shall give the names and other details of the graduate engineer / diploma engineer to whom he intends to employ or who is under employment with him, at the time of agreement and also give his curriculum vita.

(e) The Bidder shall give a certificate to the effect that the graduate engineer / diploma engineer is exclusively in his employment.

(f) A Retired Assistant Engineer who is holding a diploma may be treated at par with a Graduate Engineer for the operation of the above clause.

Note: - Such Degree or Diploma engineer must always be available on works site on day to day basis and actively supervise, instruct and guide the Bidder's works force and also receive instruction from the Departmental Engineers / Sub engineers. In case the Bidder fails to employ the required technical staff or fails to employ technical staff / personnel as submitted by the Bidder in Prequalification documents and or the technical staff/personnel so employed are generally not available on work site and or do not receive or comply the instructions of the Departmental Engineers, the Engineer-In-Charge shall recover / deduct from his bills as directed by the Engineer – In charge.

68. The tender documents have to be completed and submitted with all the documents required in the tender notice. Following is the summary of the documents required to be submitted with the completed tender form.

[a] Name, residence and place of business etc.

[b] Details of contracts already held by the Bidder.

[c] Attested copy of the constitution of firm and power of attorney.

[d] A declaration that there has been no conviction imprisonment for an offence involving moral turpitude.

[e] Declaration and description.

69. **Registration with Labor Department:** As per rule 1976 rule-21 (Form-4) or applicable laws, the successful Bidder shall submit the Labor registration Certificate after issuing the work order and prior to the Commencement of work.

70. **INDEMNIFY:** The bidder shall indemnify the FSCL and its Project Management Consultant staff on all accounts from all aspects while performing the scope of services of this project.

71. **EXTENSION OF TIME**

(i) If the contractor shall desire an extensions of time for completions of work on the ground of his having been "UNAVOIDABLY" hindered or on compensation event(s) or on any other ground(s), he must

apply giving all and complete details of such hindrances and/or compensation event(s) and/or other cause(s) in writing, to the Chief Executive Officer, through Engineer In charge positively within 15 (Fifteen) days of occurrence of such hindrance(s)/compensation event(s)/other cause(s) and seek specific extension of time (period from..... to.....).

If in the opinion of Engineer in Charge, such reasonable grounds are shown, the Engineer-in-charge shall himself grant extension of time, if the extension of time sought by the contractor is for one month or 10% (ten percent) of the stipulated period of completion, whichever is more. If the extension of time sought is more than above period mentioned, then the Engineer in Charge shall refer the case to the CEO, FSCL with his recommendation and only after his decision in this regard, the Engineer in Charge shall sanction extension of such time as decided by the CEO, FSCL.

Once the Chief Executive Officer, FSCL has decided the case of extension of time with reference to the particular application of the contractor, it will not be competent for them to review/change such a decision later on. However, the Chief Executive Officer, FSCL shall give the contractor an opportunity to be heard (orally and or in writing), before taking any final decision either of granting extension of time or permitting the contractor to complete the work by the delayed date or before refusing both.

Provided further where the Engineer In charge has recommended grant of extension of particular time contract or has refused to recommend extension of time but has recommended permitting the contractor for delayed completion, the contractor shall continue with the work till the final decision by Chief Executive Officer, FSCL.

Failure on the part of the contractor for not applying extension of time even within 30 days of the cause of such an hindrance, it shall be deemed that the contractor does not desire extension of time and that he has “Waived” his right if any to claim extension of time for such cause of hindrance.

(ii) **EXTENSION OF TIME IN CONSEQUENCE OF ALTERATIONS:** The time for the completion of the work shall be extended in the proportion that the altered, additional or substituted work bear to the original contractor’s work and certificate of the Engineer in Charge shall be conclusive as to such proportion.

(iii) **Compensation Events for consideration of extension of time without penalty:**

The following mutually agreed Compensation Events unless they are caused by the contractor would be applicable;

- a) The Chief Executive Officer FSCL does not give access to a part of the site.
- b) The Chief Executive Officer FSCL modifies the schedule of other contractor in a way, which affects the work of the contractor under the contract.
- c) The Chief Executive Officer FSCL orders a delay or does not issue drawings, specification or instructions / decisions/approval required for execution of works on time.
- d) The Chief Executive Officer, FSCL instructs the contractor to uncover or to carry out additional tests upon work, which is then found to have no defects.
- e) The Chief Executive Officer FSCL gives an instruction for additional work required for safety or other reasons.
- f) The advance payment and or payment of running bills (complete in all respect) are delayed.
- g) The Chief Executive Officer, FSCL unreasonably delays issuing a Certificate of Completion.
- h) Other compensation events mentioned- in contract if any.

72. FINAL CERTIFICATE:

On completion of the work the contractor shall be furnished with a certificate by the C.E.O, FSCL as per completion-report of the Engineer-in-charge, of such completion in the form appended at the end, but no such certificate shall be given, nor shall the work be considered to be complete until the contractor shall have removed from the premises on which the works shall be executed, all scaffolding surplus materials and rubbish, and cleaned off the dirt from all wood-work, doors windows walls, floors or other parts of any building in upon or about which the work is to be executed or of which he may have had possession for the purpose of the execution there of nor until the work; shall have been measured by the Engineer-in-charge whose measurement shall be binding and conclusive against the contractor. If the contractor shall fail to comply with the requirements of this clause as to removal of scaffolding surplus materials and rubbish and cleaning of dirt on or before the date fixed for the completion of the work, the Engineer-in-charge may, at the expense of the contractor remove such scaffolding, surplus materials and rubbish and dispose of the same as he thinks fit and clean off such dirt as aforesaid and the contractor shall forthwith pay the amount of all expenses so incurred, and shall have no claim in respect of any such scaffolding or surplus materials as aforesaid, except for any sum actually realized by the sale thereof.

73. Price Adjustment :

- (i) Contract price shall be adjusted for increase or decrease in rates and prices of cement, reinforcement steel and bitumen in accordance with the principles and procedures and as per formula given.
- (ii) To the extent that full compensation for any rise or fall in cost to the contractor is not covered by the provision of this or other clauses in the contract, the unit rates and prices included in the contract shall be deemed to include amounts to cover the contingency of such other rise or fall in costs

The formula for price adjustment of prices are:

Adjustment of price for bitumen:

Price adjustment for increase or decrease in the cost of bitumen shall be paid as follows:

That the rate of bitumen/ emulsion at the refinery on the date of close for financial bidding shall be considered as base rate if during execution of the works, the rate of bitumen/ emulsion increase or decrease at refinery, the difference in cost shall be paid/ recouped from the contractor in the bill, subject to the following conditions:-

The contractor shall submit original bill/ voucher of the refinery while claiming the payment for the work done. The bill/ voucher should pertain to the period of original contractual time limit and should correspond with the progress of work. No extra payment due to increase in rate of bitumen / emulsion will be paid if the original bill/ voucher are not submitted by the agency.

No increase in prices of the bitumen / emulsion shall be reimbursed to the contractor beyond the original time period allowed for construction as per contract agreement irrespective of extension of time limit granted to the agency for any reason, whatsoever. However, decrease in price of bitumen/emulsion shall be recouped from the contractor even beyond the original time period allowed for construction.

After approval of tender, the contractor shall submit the work programme for execution of work and get it approved from the Engineer-in-Charge in the time limit prescribed in the tender

document. The increase in rates of bitumen, emulsion shall only be paid if the bitumen work is carried out within the prescribed period as per approved work programme.

Only actual difference of rates of Bitumen will be payable / deductible to the contractor. No overhead charges and contractor profit etc. are to be added / deleted, no tender premium is to be added / deleted.”

The contractor can arrange the bitumen from any of the refinery or import the same subject to the condition that the quality of bitumen is as per the requirement of contract and specifications. Regarding payment of price variation of bitumen as per the agreement, that the escalation de-escalation will be paid on the basis of lesser cost implication to Department / Government on consideration of the difference in rates as given below subject to financial regularity and other terms and conditions of agreement :-

- (a) Prevailing rates of **IOC refineries at Mathura at the time of tender** and at the time of purchase of bitumen.
- (b) Prevailing rates at the source from which the bitumen is purchased by the contractual agency at the time of tender.

It is further clarified that:-

When recovery is due on account of decrease in rates of bitumen, higher of the difference in rates of IOC Mathura and that of private refinery / Sector, shall be considered.

When escalation is due to increase in rates of bitumen is due to agency, then lesser of the difference in rates of IOC Mathura and that of private refinery / Sector, from whom bitumen was purchased, shall be considered.

Adjustment for grey cement :

Price adjustment for increase or decrease in the cost of grey cement shall be paid as follows:

If after submission of the, the price of grey cement incorporated in the works (not being a material supplied from the Engineer-in-Charge's Store) increase (s) beyond the price (s) prevailing at the time of the last stipulated date for financial bid closing of tenders (including extensions, if any) for the work, then the amount of the contract shall accordingly be varied and provided further that any such increase shall not be payable if such increase has become operative after the stipulated date of completion of work in question.

If after submission of the, the price of grey cement / or steel reinforcement bars incorporated in the works (not being a material supplied from the Engineer-in-Charge's Store) is decreased, Govt. shall in respect of these materials incorporated in the works (not being materials supplied from the Engineer-in-Stores) be entitled to deduct from the dues of the contractor such amount as shall be equivalent to the difference between the prices of grey cement as prevailed at the time of last stipulated date for receipt of tenders including extensions if any for the work and the prices of these materials on the coming into force of such base price of grey cement and issued under authority of Engineer-in-Chief, Haryana PWD B&R, Chandigarh.

It is further clarified that the decrease in the prices of grey cement and shall be deducted from the dues of the contractor if such decrease has become operative after the stipulated date of completion of work in question and increase shall not be payable if such increase shall not be payable if such increase has become operative after the stipulated date of completion of work in question.

The increase/ decrease in prices shall be determined by the All India Wholesale Prices Indices for grey cement as published by the Economic Advisor to Government of India, Ministry of Commerce and Industry) and base price for grey cement as issued under authority of Engineer-in-Chief, Haryana PWD B&R, Br. Chandigarh as valid on the last stipulated date of receipt of tender, including extension if any and for the period under consideration.

The amount of the contract shall accordingly be carried for grey cement will be worked out as per the formula given below:-

Adjustment for component of “Grey Cement”

$$V_c = P_c \times Q_c \times \frac{CI - CI_0}{CI_0}$$

CI_0

Where,

V_c = Variation in grey cement cost i.e. increase or decrease in the amount in rupees to be paid or recovered.

P_c = Base price of grey cement as issued under authority of Engineer-in-Chief, Haryana PWD B&R, Br. Chandigarh valid at the time of the last stipulated of receipt of tender including extension if any.

Q_c = Quantity of grey cement used in the works since previous bill.

CI_0 = All India wholesale price index for grey cement as published by the Economic Advisor to Government of India, Ministry of Industry and Commerce as valid on the last stipulated date of receipt of tenders including extensions if any.

CI = All India wholesale price index for grey cement for period consideration as published by the Economic Advisor to Government of India, Ministry of Industry and Commerce

Adjustment for

steel/Rebars

$$V_s = P_s \times Q_s \times \frac{SI -$$

SI_0

SI_0

V_s = Variation in cost of steel reinforcement rebars i.e. increase or decrease in the amount in rupees in the amount in rupees to be paid or recovered.

Ps = Base price of steel reinforcement bars, as issued under authority of Engineer-in-Chief, Haryana PWD B&R Br., Chandigarh at the time of the last stipulated date of receipt of tender including extensions, if any.

Qs= Quantity of steel paid either by way of secured advance or used in the works since previous bill (Whichever is earlier).

S1o= All India wholesale Price Index for Steel (rebars) for the period under consideration as published by Economic Advisor to Government of India, Ministry of Industry and Commerce as valid on the last stipulated date of receipt of tenders including extensions, if any.

S1= All India Wholesale Price Index for Steel (rebars) for the period under consideration as published by Economic Advisor to Government of India, Ministry of Industry and Commerce.

74. RATES FOR WORKS NOT IN SCHEDULE OF RATES:

And if the altered, additional or substituted work includes any class of work, for which no rate is specified in this contract, then such classes of the work shall be carried out at the rates entered in the applicable schedule of rates which was in force on the date of tender provided that when the tender for the original work as a percentage below/above the schedule of rates, the altered, additional or substituted work required as aforesaid shall be chargeable at the said schedule of rate minus/plus the same percentage deduction, addition and such class of work is not entered in & arrange to carry in out in such manner as may be considered advisable provided always & if the contractor shall commence work or incur any expenditure in regard thereto before the rates shall have been determined as lastly herein before mentioned than & In such case he shall only be entitled to the paid in respect of the work carried to such rate or rates be fixed by the Chief Executive Officer in the event of a dispute the decision of the Chief Executive Officer, shall be final.

If the contractor commence non-schedule work or incur expenditure in regard there to before the rates shall have been determined by the Chief Executive Officer than he shall be entitled for payment for the work done as may be finally decided by the Chief Executive Officer. In the event of dispute, the decision of the Chief Executive Officer shall be final.

75. CLAIM OR COMPENSATION :

- (i) **Claims for compensation for delay in starting the work** :No compensation shall be allowed for any delay caused in the starting on the work on account of acquisition of land, or in the case of clearance work, on account of any delay in according sanction to estimates.
- (ii) Quantities shown in the tender are approximate and no claim shall be entertained for quantities of work executed being either more or less than those entered in the tender of estimate.
- (iii) **No claim to any payment or compensation for alteration in or restriction of works:** If at any time after the execution of the contract documents, the Engineer – in – Charge shall for any reason whatsoever require the whole or any part of the work as specified in the tender to be stopped for any period or shall not require the whole or part of the work to be carried out at all or to be carried out by the contractor he shall give notice in writing of the fact to the contractor who shall thereupon suspend or stop the work totally or partially, as the case may be.

If any such case, except as provided hereunder, the contractor shall have no claim to any payment or compensation what so ever on account of any profit or advantage which he might have derived from the execution of the work in full, but which he did not so derive in consequence of the full amount of the work not having been carried out, or on account of any loss that he may be put to on account of materials purchased or for unemployment of labor recruited by him. He shall not

also have any claim for compensation by reason of any alteration having been made in the original specifications, drawing, designs and instructions, which may involve any curtailment of the work as originally contemplated. Where, however, materials have already been purchased or agreed to be purchased by the contractor shall be paid for such materials at the rates determined by the Engineer-in-charge, provided they are not in excess of requirement and of approved quality and / or shall be compensated for the loss, if any that he may be put to, in respect of materials agreed to be purchased by him, the amount of such compensation to be determined by the CEO whose decision shall be final. If the contractor suffers any loss on account of his having to pay labor charges during the period during which the stoppage of work has been ordered under this clause, the contractor shall, on application be entitled to such compensation on account of labor charges as the CEO, whose decision shall be final, may consider reasonable provided that the contractor shall not be entitled to any compensation on account of labor charges, if in the opinion of the Engineer – in – charge, the labor could have been employed by the contractor elsewhere for the whole or part of the period during which the stoppage of the work has been ordered as aforesaid.

76. ACTION AND COMPENSATION :

- (i) **Action and compensation payable in case of bad work :** If at any time before the security deposit is refunded to the contractor, it shall appear to the Engineer – in – charge or his subordinate in charge of the work, that any work has been executed with unsound, imperfect or unskillful workmanship or with material of inferior quality or that any materials or articles provided by him for the execution of the work are unsound, or of a quality inferior to that contracted for, or are otherwise not in accordance with the contract, it shall be lawful for the Engineer – in – charge to intimate this fact in writing to the contractor and then notwithstanding the work, materials or articles complained of may have been Inadvertently passed, certified and paid for contractor shall be bound forthwith to rectify, or remove and reconstruct the work so specified in whole or in part, as the case may require, or if so required, shall remove the materials or articles so specified and provide other proper and suitable materials or articles at his own proper charge and cost, and in the event of his failing to do so with in a period to be specified by the Engineer – in – charge in the written intimation aforesaid ,the contractor shall be liable to pay compensation at the rate of one percent on the amount of contract put to tender every day not exceeding ten percent, during which the failure so, continues and in the case of any such failure the Engineer – in – charge may rectify or remove and, re-execute the work or remove and replace the materials or articles complained of as the case may be at the risk and expense in all respects of the contractor. Should the Engineer-in-charge consider that any such inferior work or materials as described above may be accepted or made use of it shall be within his discretion to accept to the same at such reduced rates as he may fix therefore. This shall be exclusive of, and will be in addition to any action being taken under other clause of the contract.
- (ii) **Compensation for damage of electrical items:** During the Defect Liability Period and Operatton & Mentainance Period, if any damge of Electrical items which is not attributable to Contractor and damage has been caused due to DHBVN, the cost of same shall be bourn by DHBVN. If the damage will be occurred due to contractor's fault then cost of same shall be bourn by Contractor. The decision of FSCL in this regards shall be final and binding to both the parties.
- (iii) In any case in which under any clause or this contract the Bidder shall have renders himself liable to pay compensation amounting to the whole of the security deposit (whether paid in one sum or deducted by installments) or committed a breach of any terms in Fair Wages or in the case of delays beyond three months or in case of abandonment of the work owing to the serious illness or death of the Bidder or any other cause, Engineer-In-Charge on behalf of the FSCL shall have power to adopt anyone of the following courses, as he may deem best suited to the interest of the Board.
 - (a) The rescind of contract, (of which recession notice in writing to the Bidder under the hand of the Engineer-In-Charge shall be conclusive evidence) and in which case the security deposit of the Bidder shall stand forfeited and be absolutely at the disposal of the Board.
 - (b) To employ labour paid by the FSCL or by employing FSCL machinery and to supply materials to

carry out work, or any part of the work, debiting the Bidder with the cost of the labour or hire charge of FSCL machinery and the price of the materials (of the amount of which cost and price, a certificate of the Engineer-In-Charge shall be final and conclusive against the Bidder) and crediting him with the value of the work done, in all respects in the same manner and the same rates as it had been carried out by the Bidder under the terms of this contract or the cost of the labour and the price of the materials as certified by the Engineer-In-Charge whichever is less the certificate of the Engineer-In-Charge as to the value of the work done shall be final and conclusive against the Bidder. This does not qualify the Bidder to any refund if the work is carried out at lower rates than the rates quoted by the Bidder. Saving, if any, will go to the Board.

- (c) To measure up the work of Bidder and to take such part thereof as shall be unexecuted out of his hands and to give it to another Bidder to complete in which case any expenses which may be incurred in excess of the sum which would have been paid to the original Bidder if the whole work had been executed by him (of the amount of which excess certificate in writing or the Engineer-In-Charge shall be final and conclusive) shall be borne and paid by the original Bidder and may be deducted from any money due to him by FSCL under the contract or otherwise or from his security deposit or the proceeds of sale thereof or a sufficient part thereof. The same provision of recovery of the difference amount will apply in case of failure in compliance on part of the Bidder to execute the work or part of the work as per work and time schedule. Engineer-In-Charge will have the right to decide as to which work or which part of work / item is to be put in fresh tender in case of failure in execution as the part of the Bidder.
- (d) In the event of any of the above courses being adopted by the Engineer-In-Charge, the Bidder shall have no claim to compensation for any loss sustained by him by reason of his having purchased or procured any materials or entered into any agreement or made advances on account of or with a view to the execution of the work or the performance of the contract. And in case the contract shall be rescind under the provisions aforesaid, the Bidder shall not be entitled to recover or to be paid any sum for any work thereof actually performed under this contract, unless and until the Engineer-In-Charge will have certified in writing the performance of such work and the value payable in respect thereof and he shall only be entitled to be paid the value so certified.
- (iv) **Notice to be given before work is covered up:**The contractor shall give not less than five day notice in writing to the Engineer-in-charge or his subordinate in charge of the work before covering tip or otherwise placing beyond the reach of measurement any work in order that the same may be measured, and correct dimensions thereof be taken before the same is so covered up or placed beyond the reach of measurement, any work without the consent in writing of the Engineer-in charge or his subordinate in charge of the work and if any work shall be covered up or placed beyond the reach of measurement without such notice having been given or consent obtained, the same shall be uncovered at the contractors expenses, or in default thereof, no payment or allowance shall be made for such work or the materials with which the same was executed.

77. LIABILITY AND INDEMNITY :

- (i) **Contractor Liable For Damage Done And For Imperfections After Certificate Of Completion**
:If the contractor or his work people or servants shall break, deface injure or destroy any part of infrastructure in which they may be working or any building, road, road curbs, fences, enclosures, water pipes, cables drains, electric or telephone posts or Wires trees grass or grassland or cultivated ground continuous to the premises on which the work or any part of it is being executed, or if any damage shall happen to the work while in progress, from any cause whatever, or any imperfections become apparent ,the contractor shall make good the same at his own expense or in default, the CEO may cause the same to be made good by other workmen and deduct the expense of which certificate of the Engineer-in charge shall be final) from any sums that may be then or at any time thereafter, may become due to the contractor or from his security deposits, or the proceeds of sale thereof or of a sufficient portion thereof.

78. COMPENSATION UNDER SECTION 12 SUB-SECTION (1) OF THE WORKMAN'S COMPENSATION ACT 1923:

In every case in which by virtue of the provisions of section 12 sub-section (1) of the workman's compensation Act 1923 FSCL is obliged to pay compensation to a workman employed by the contractor in execution of the works, CEO, FSCL will recover from the contractor the amount of compensation so paid and without prejudice to the rights of FSCL under section (1) sub-section (2) of the said Act. CEO, FSCL shall be at liberty to recover the amount or any part thereof by deducting it from the security deposit or from any sum due by FSCL to the contractor whether under this contract or otherwise. FSCL may not be bound, to contest any claim made against them under section - 12 subsections (1) of the said Act except on the written request of the contractor and upon his giving to FSCL full security for all cases for which FSCL might become liable in consequence contesting such claim.

79. CHANGE IN THE CONSTITUTION OF FIRM:

In the case of tender by partners any change in the constitution of the firm shall be forthwith notified by the contractor to the CEO for his information, and contractor shall initiate steps for fresh & new registration which shall be assessed & decided by the competent authority for fresh registration.

80. EMPLOYMENT OF SCARCITY LABOUR:

If FSCL declare a state of Scarcity or famine to exist in any village situated within sixteen kilometers of the work the contractor, shall employ upon such parts of the work as are suitable for unskilled labor, any person certified to him by the CEO FSCL or by any person to whom the CEO FSCL may have delegated this duty in writing to be in need of relief and shall be bound to pay to such persons wages not below the minimum which FSCL may have fixed in this behalf. Any dispute, which may arise in connection with the implementation of this clause, shall be decided by the FSCL whose decision shall be final and binding on the contractor

81. PENALTY FOR BREACH OF CONTRACT:

On the breach of any term or condition of this contract by the contractor the said CEO, FSCL shall be entitled to forfeit the Security deposit or the balance thereof that may at the time be remaining, and to realize and retain the same as damages and compensation for the said breach but without prejudice to the right of the CEO to recover further sums as damages from any sums due or which may become due to the contractor By FSCL or otherwise howsoever.

82. JURISDICTION : All disputes or claim arising out of this contract shall be subject to the jurisdiction of courts in Faridabad, Haryana.

83. INTERPRETATION:

84.1 In interpreting these conditions of Contract, singular also means plural, male also means female or neuter, and the other way around. Headings have no significance. Words have their normal meaning under the language of the Contract unless specifically, defined. The Engineer will provide instructions clarifying queries about the conditions of Contract.

84.2 If sectional completion is specified in the contract Data; references in the conditions of Contract to the Works, the Completion Date, and the Intended Completion Date apply to any Section of the Works (other than references to the Completion Date and Intended completion date for the whole of the Works).

84.3 The documents forming the Contract shall be interpreted in the following order of priority:

- (1) Agreement
- (2) Letter of Acceptance, notice to proceed with the works
- (3) Contractor's Bid

- (4) Conditions of Contract including General Conditions of Contract and Special Conditions of Contract
- (5) Specifications
- (6) Drawings, if any.
- (7) Bill of quantities and all Annexures, Appendices and Forms
- (8) any other document listed in the **Special Conditions of Contract** as forming part of the Contract.

84. Video photography of the works.:

The contractor shall do video photography of the site firstly before the start of the work, secondly mid-way in the execution of different stages of work and lastly after the completion of the work. Video photography of all items which will be subsequently covered and difficult to be measured afterwards shall be done for record. No separate payment will be made to the contractor for this. VCD before start of work will be submitted to the Engineer and copy of the same to the employer for record within one month from start of work. VCD after completion of work will also be submitted to the Engineer and the employer within one month after completion of work.

85. Operating and Maintenance Manuals “As built” Drawings and operating and maintenance manuals shall be supplied the Contractor within one month of issue of completion certificate. If the Contractor does not supply the Drawings and/or manuals by the stipulated date or they do not receive the Engineer’s approval, the Engineer shall withhold INR 2 lakhs from payments due to the Contractor.

SECTION 6: SPECIAL CONDITIONS OF CONTRACT

- 6.1 **General:** The special conditions are supplementary instructions to the tenders and shall form part of the contract.
- 6.2 **Drawing:** All Drawings/Layout plans given in Section 7 are for reference or guidance purpose only. The Bidder will submit the detailed construction plan of construction of Smart Road within 15 days from date of issuing work order or Agreement whichever is earlier. The same shall be reviewed and approved by Engineer – In charge of FSCL or through other agency approved by FSCL. This 15 days period is included in stipulated time for construction. Construction of Smart Road shall be carried out as per the approved drawings provided by FSCL.
- 6.3 **Data to be furnished by the Bidder:** The Bidder shall submit the following information to the Engineer-in-charge.
- 6.4 Proposed constructions Programme and time schedule showing sequence of operations within **15 days** of receipt of notice to proceed with the work in pursuance of the conditions of contract.
- 6.5 **Action when the progress of any item of work is unsatisfactory:** If the progress of a item of work during construction, which is important for timely completion of work is unsatisfactory, the Engineer-in-charge shall not withstanding that the general progress of work is satisfactory, after giving the Bidder **15 days'** notice in writing get the said work executed by employing other means including other labour / Bidder etc. and the Bidder will have no claim for compensation for any loss sustained by him owing to such action.
- 6.6 In case if any of the works under this contract are found unsatisfactorily by the Engineer in charge, the E in C shall either request the bidder to rectify the defect immediately or at his discretion may have it done by others (vendor or contractor) and deduct the actual amount incurred as per market rate plus 15 % extra incurred in such works from the bidders.
- 6.7 **Inspection and Tests:** Except as otherwise provided in here of all material and workmanship if not otherwise designated by the specifications shall be subject to inspection, examination and test by the Engineer-in-Charge at any and all times during manufacture and/or construction and at any/all places where such manufacture or constructions are carried on. The Engineer-in charge shall have the right to reject defective materials and workmanship or require its corrections. Rejected workmanship shall be satisfactorily replaced with the proper material without charge thereof and the Bidder shall properly segregate and remove the rejected material from the premises. If the Bidder fails to proceed at once with the replacement of the rejected material and/or the construction of defective workmanship the Engineer-in charge may replace such material and/or correct such workmanship and charge the cost thereof to the Bidder.
- The Bidder shall be liable for replacement of defective work up to the time of completion of DLP in accordance with the conditions of contract of all work to be done under the contract. The Bidder shall furnish promptly without additional charge all facilities, labour and material necessary for the safe and convenient inspection and tests that may be required by the Engineer-in-Charge. All inspections and tests by the departments shall be performed in such a manner as to not unnecessarily delay the work. Special full size and performance test shall be charged with any additional cost of inspection when materials and workmanship are not kept ready by the Bidder at the time of inspection.
- 6.8 **Removal of temporary work, Plant & Surplus materials:** Prior to final acceptance of the completed work, but excepting as otherwise expressly directed or permitted in writing, the Bidder shall, at his own expenses remove from the site and dispose of all the temporary structures including buildings, all plant and surplus materials, and all rubbish and debris for which he is responsible to the satisfaction of Engineer-in-Charge.
- 6.9 **Possession prior to completion:** The Engineer-in-Charge shall have the right to take possession of or use any completed part of the work. Such possession or use shall not be deemed as an

acceptance of any work not completed in accordance with the contract.

- 6.10 **Damage to works:** The works whether fully completed or incomplete, all the materials, machinery, plants, tools, temporary building and other things connected there with shall remain at the risk and in the sole charge of the Bidder until the completed work has been delivered to the Engineer-in- Charge and till completion certificate has been obtained from the Engineer in-charge. Until such delivery of the completed work, the Bidder shall at his own cost take all precautions reasonably to keep all the aforesaid works, materials, machinery, plants, temporary buildings and other things connected there with free from any loss, damages and in the event of the same or any part there of being lost or damaged, he shall forthwith reinstate and make good such loss or damages at his own cost.
- 6.11 **Examination and tests on completions:** On the completion of the work and not later than three months thereafter, the Engineer-in-charge shall make such examination and tests of the work as may then seem to him to be possible, necessary or desirable, and the Bidder shall furnish free of cost any materials and labour which may be necessary thereof and shall facilitate in every way all operations required by the Engineer-in-Charge, in making examination and tests.
- 6.12 **Climatic Conditions:** The Engineer-in-Charge may order the Bidder to suspend any work that may be subject to damage by climatic conditions and no claims of the Bidder will be entertained by the department on this account.
- 6.13 As per the Ministry of Environment and Forest Guidelines 2010 and Ministry of Urban Development notifications, the Site area shall be protected from dust by fixing Green Fencing around the Construction site area.
The Contractor is instructed to strictly adhere to the following at his own cost.
- a) Supply and Fixing Green barriers and wind breaking walls around their sites.
 - b) Cover tarpaulin on scaffolding around area of construction,
 - c) Do not store construction material, particularly sand, on any part of the street, roads in any colony,
 - d) Cordon the work area with proper fencing by other means with due consideration of safety of workers, public, etc.
 - e) Dust emissions from construction site are controlled.
 - f) Sprinklers should be compulsorily used at the site and Wet jets in grinding and stone cutting must be used.
 - g) The work area shall be well illuminated during nights.
- 6.14 **Safety regulations:** During the entire contract period, while carrying out this works indicated in this tender, the Bidder will ensure compliance of all safety regulations as provided in the Safety Code (Annexure - D). The bidder will be responsible for safety of the works.
- 6.15 **The Bidder will make his own arrangement:** for supply of Water, Light & Power for his works and labour camps etc.: The Bidder will make his own arrangement for supply of water, light and power for his works and labour camps etc. The department will not entertain any claim what so ever for any failure or break down etc. in supply of to the Bidder. The Bidder will supply and fix his own tested meter of the approved make but the meter will be kept in the custody of the department.
- 6.16 **Interference with other Bidders:** The Bidder must not interfere with other Bidders who may be employed simultaneously or otherwise by the department at the Site. He will at no time engage departmental labour or that of other Bidders without the written permission of the Engineer-in-Charge. **Bidder is fully responsible for cause of damages of the adjoining works of different works at site and the same cost of rectification of damages shall be recovered from the Bidder as per Engineer In-charge instructions.**

- 6.17 **Regulations and bye laws:** The Bidder shall conform to the regulations, bye-laws any other statutory rules made by any local authorities or by the Government and shall protect and indemnify FSCL, against any claim or liability arising from or based on the violation of any such laws, safety, theft, ordinance, regulation, orders, decrees etc.
- 6.18 **Site Order Book:** A site order book shall be kept in the departmental office at the site of the work. As far as possible all orders regarding the works are to be entered in this book. All entries therein shall be signed by the departmental officers in direct charge of the work and the Bidder or his representatives. In the important cases the CEO or TA/GM/DGM of FSCL will countersign the entries which shall except with the written permission of the TA and the Bidders or his representative shall be bound to take note of all instructions meant for the Bidder as entered in the site order book without having to be called for separately to note them. The Engineer-in-charge shall submit periodically copies of the remarks of the site order book to the CEO, FSCL for record and to the Bidder for compliance and report.
- 6.19 **Conversion of units:** Whenever in the contract agreement dimensions and units have been expressed in F.P.S. system, the same will be converted in to metric system units by applying the standard conversion table of Indian Standard Institution so as to derive the corresponding figure arithmetically and the Bidder will have to accept the figures so derived without any claim or compensation whatsoever.
- 6.20 **Rights of other Bidders and persons:** If, during the progress of the work covered by this contract, it is necessary for other Bidders or persons to do work in or about the site of work, the Bidder shall afford such facilities, as the Engineer-in-charge may require.
- 6.21 **Employment of technical persons:** The Bidder shall employ or produce evidence of having in his employment a qualified technical person not below the rank of a Graduate Engineer from an Institution recognized by the Government of Haryana / Govt. of Other State / Govt. of India.
- 6.22 The above is the minimum requirement of Manpower. However contractor shall access the actual requirement and deploy the necessary manpower. The bidder shall include the cost of extra manpower if required in the Operation & Maintenance cost. No extra cost will be paid for deployment of extra manpower if required.
- 6.23 The technical staff shall be got approved in writing from the Engineer (whose approval may be withdrawn any time) for supervision of works and to receive direction from the Engineer of the work on behalf of the contractor. The supervisory staff of the contractor will not be changed without the approval of the Engineer.
- 6.24 FSCL holds the right to generate the revenue and collect from the Smart Road. Contractor shall not claim any revenue generated from the Smart Road.
- 6.25 ADVANCES TO BIDDERS:**
No Advance either Mobilization or Secured amount will be paid to the bidder.
- 6.26 Escalation: No escalation whatsoever shall be paid.
- 6.27 **Scope of Unit rate Contract:** The unit rate contract shall comprise of construction of Smart Road which includes provision of all labour, materials, constructional plants, tools and tackles, transport and all works of a temporary or permanent nature required for such works as indicated above in so far as is necessary for providing the same and is specified in the contract.
- 6.28 Ground water level variation: It is liable to vary. No claim due to variation of low water level shall be entertained.

DETAILED PAYMENT SCHEDULE:

- 6.29 Schedule of running payment:

1. The Contractor shall submit running bills by 3rd of the every month. The payment will be based on the works billed in the Monthly running bills.
2. The Contractor representative and the FSCL staff shall collectively measure the quantities claimed in the Monthly bill.. The Monthly bill will be paid upon approval of the measurement from the FSCL.

Notes: [For 6.29]

1. The payments as indicated above are for complete works.
2. The Engineer in Charge may provide Adhoc payments to the contractor. However, the Adhoc payments shall be in proportion to the works executed and in no case shall it be more than the percentage stipulated for each phase in the payment schedule. The Engineer in Charge shall estimate the work done as per the milestones provided in the payment schedule and decide upon the proportion of executed works.
3. The milestones indicated above are for payment purpose and may therefore not indicate all items that have to be executed as part of the works under this tender. The payments for all such items, even though not explicitly mentioned above, shall therefore be deemed to have been included in the schedule mentioned above and no separate or additional payments whatsoever shall be made.
4. The Engineer in Charge shall verify the sum of all Adhoc payments made to the contractors and deduct the excess amount if paid over the stipulated percentage for milestones as provided in the payment schedule.
5. The Engineer- In-Charge, FSCL may require the Bidder to extend the validity period of the Bank Guarantee(s) for such period which he considers it proper and the Bidder shall extend the validity period of such Bank Guarantee accordingly, if the Bidder fails to extend the period accordingly, the Engineer-In-Charge, FSCL may encash the B.G. before the expiry of the validity period.
6. The Bidder shall carryout all necessary rectifications of defects noticed, caused due to any reasons at his own cost within such reasonable period as mentioned in such communication notice from the Engineer-in-Charge, FSCL to him.
7. Failure of Bidder to rectify the defects properly in the given period, it shall be open for the Engineer-In-Charge, FSCL to get the defect(s) rectified either departmentally or through other agency (Without calling any tender / Quotation) and recover the actual amount incurred as per market rate plus 15 % (Fifteen per cent) of such cost from the Bidder from any sum, in any form available with the department.
8. During the Constuction and O & M period, If the Bidder or his work people shall break, deface, injure or destroy any part of building in which they may be working or any building road curbs, fences, enclosures, water pipes, cable\s, drains, electric or telephone posts or wires, trees, grassland cultivated ground continuous to the premises on which the work or any part of it is being executed or if any damage shall happen to the work while in progress from any cause whatever, or any imperfections become apparent in it within three months(Six month in the case of road works) after a certificate final or otherwise or its completion shall have been given by the Engin eer-In-Charge as aforesaid the Bidder shall make good the same at his own expense or in default the Engineer-In-Charge may cause the same to be made good by other work men and deduct the expense of which certificate of the Engineer-In-Charge shall be final) from any sum that may be then or at any time thereafter, may become, due to the Bidder or from his security deposits, or the proceeds of sale thereof or of a sufficient portion thereof.
9. The Bidder hereby also covenants that it shall be his responsibility to see that the Smart Road constructed under this contract do/ does not leak during the rainy seasons period of DLP after

- its completion and if any defects are pointed out to him by the Engineer-In-Charge during the said period the same shall be removed by him own expenses or in default the Engineer-In-Charge. The Bidder needs to provide 10 years warrantee period from water proofing.
10. Proportional part payment may be made for incomplete items of work. These part payments shall be at the sole discretion of the Engineer-In-Charge of the Project.
 11. The Bidder/Bidder shall give in advance authority letters(s) in favour of the Engineer-In-Charge of the Project authorizing him to get all Banks' Fixed deposit security, Bank Guarantees (either normal security deposit and or for performance security) to get these Bank Receipts and Guarantee deeds verified and confirmed from the concerned Bank. It will be only after getting such confirmation that the Engineer-In-Charge of the Project shall pay any amount accordingly or refund the equal amount for which BG submitted has been duly verified and confirmed.
 12. The Bidder shall not remove minor mineral from borrow areas/ Quarries without prior payment of Royalty charges.
 13. Extra work and rebate: Extra /Rebate work arising out of this contract shall be valued at HSR rate. If the rates are not available at HSR then the rate for such items shall be worked out by the Bidder in consultation with the Engineer-in-charge and approved by the Chief Executive Officer, FSCL. Such approval of rate[s] must invariably be obtained before taking-up of execution of such item[s] of work. This approved rate shall be final and binding on the Bidder.
 14. **This is a unit rate contract where time is of utmost importance. No claims of any sort with regard to escalation shall be admissible and therefore no payment what so ever in this regard shall be made.**

Project Management Consultancy:

OBJECTIVE The objective of this Consultancy (the "Objective") is to assist the FSCL in implementation of the Project till the successful completion and handing over of all works to the FSCL and comprehensively supervise the works and activities carried out by the Bidder(s) as "Engineer's Representative" under the respective contract(s) in a manner that would ensure:

- a. Total compliance of technical specifications and various other requirements contained in the respective contracts by the Bidder(s);
- b. High standards of quality assurance system in the Consultancy as well as the works and activities of the Bidder(s);
- c. Comprehensive and documented reporting to the FSCL of Consultant's own activities, progress of the Project(s) and compliances/ non-compliances by the Bidder(s);
- e. Proper verification of measurements and bills submitted by the Bidder(s) so that payments made by the FSCL against these bills truly reflect the actual work done at site complying with the requirements of the respective contract(s);
- f. proper interface and coordination among the FSCL, Bidder(s), other Bidders/ Bidders and local bodies/ state government; and
- g. Full documentation of the completed works including applications for various approvals.

The objectives of the PMC is not limited to the above, CEO of FSCL have discretion implement other objectives or the completion of the project.

SECTION 7:

DESIGNS AND SPECIFICATIONS

This section has to be read along with the information provided in Scope of Tender in ITT Section 2

7.1. Drawings & Design:

FSCL will provide the following Drawings & these drawings are enclosed in NIT:

1. Existing layout plan of wet utilities.
2. Proposed layout plan of wet utilities.
3. Proposed X section of different roads(Phase I&II)
4. Typical manhole section for sewers
5. Typical valve chamber section for water supply

List of Drawings		
Sl.No.	Drawing Title	Drawing No.
1	PROPOSED SECTION (AMBEDKAR ROAD)	FSCL/PMC/SR/AR/SEC-01
2	PROPOSED SECTION (TALAB ROAD)	FSCL/PMC/SR/AR/SEC-02
3	PROPOSED SECTION (TALAB ROAD)	FSCL/PMC/SR/AR/SEC-03
4	PROPOSED SECTION (LINK ROAD)	FSCL/PMC/SR/AR/SEC-04
5	PROPOSED SECTION (SECTOR 19 INTERNAL ROADS)	FSCL/PMC/SR/AR/SEC-05
6	PROPOSED SECTION (SECTOR 19 INTERNAL ROADS)	FSCL/PMC/SR/AR/SEC-06
7	PROPOSED SECTION (BADKHAL ROADS)	FSCL/PMC/SR/AR/SEC-07
8	DETAILS OF INTERSECTION AT CH. 00+000 (AMBEDKAR MARG AT GRADE INTERSECTION)	FSCL/PMC/SR/RD/INT./01
9	DETAILS OF INTERSECTION AT CH. 00+700 (AMBEDKAR MARG AT GRADE INTERSECTION)	FSCL/PMC/SR/RD/INT./02
10	DETAILS OF INTERSECTION AT CH. 01+994 (AMBEDKAR ROAD BYEPASS)	FSCL/PMC/SR/RD/INT./03
11	DETAILS OF INTERSECTION AT CH. 00+320 (TALAB ROAD AND SECTOR 19 AT GRADE INTERSECTION)	FSCL/PMC/SR/RD/INT./04
12	DETAILS OF INTERSECTION AT CH. 00+790 (TALAB ROAD AT GRADE INTERSECTION)	FSCL/PMC/SR/RD/INT./05
13	DETAILS OF INTERSECTION AT CH. 01+300 (TALAB ROAD AT GRADE INTERSECTION)	FSCL/PMC/SR/RD/INT./06
14	DETAILS OF INTERSECTION AT CH. 01+550 (ANKHEER CHOWK AT GRADE INTERSECTION)	FSCL/PMC/SR/RD/INT./07
15	DETAILS OF INTERSECTION AT CH. 00+000 (BADKHAL CHOWK AT GRADE INTERSECTION)	FSCL/PMC/SR/RD/INT./08
16	STA:0+000 TO 0+500 PLAN/PROFILE TALAB ROAD	FSCL/PMC/SR/RD/PP/05
17	STA:0+500 TO 1+000 PLAN/PROFILE TALAB ROAD	FSCL/PMC/SR/RD/PP/06
18	STA:1+000 TO 1+467PLAN/PROFILE TALAB ROAD	FSCL/PMC/SR/RD/PP/07
19	STA:0+000 TO 0+500 PLAN/PROFILE LINK ROAD	FSCL/PMC/SR/RD/PP/08
20	STA:0+500 TO 0+700 PLAN/PROFILE LINK ROAD	FSCL/PMC/SR/RD/PP/09
21	STA:0+500 TO 0+387 PLAN/PROFILE SECTOR-19 ROAD 1-1	FSCL/PMC/SR/RD/PP/10
22	STA:0+000 TO 0+500 PLAN/PROFILE SECTOR-19 ROAD 1-1	FSCL/PMC/SR/RD/PP/11
23	STA:0+500 TO 0+603 PLAN/PROFILE SECTOR-19 ROAD 1-2	FSCL/PMC/SR/RD/PP/12
24	STA:0+000 TO 0+500 PLAN/PROFILE SECTOR-19 ROAD-2	FSCL/PMC/SR/RD/PP/13
25	STA:0+500 TO 1+000 PLAN/PROFILE SECTOR-19 ROAD-2	FSCL/PMC/SR/RD/PP/14
26	STA:1+000 TO 1+082 PLAN/PROFILE SECTOR-19 ROAD-2	FSCL/PMC/SR/RD/PP/15
27	STA:0+000 TO 0+500 PLAN/PROFILE BADKHAL ROAD	FSCL/PMC/SR/RD/PP/16
28	STA:0+500 TO 1+000 PLAN/PROFILE BADKHAL ROAD	FSCL/PMC/SR/RD/PP/17
29	STA:1+000 TO 1+500 PLAN/PROFILE BADKHAL ROAD	FSCL/PMC/SR/RD/PP/18
30	STA:1+500 TO 2+000 PLAN/PROFILE BADKHAL ROAD	FSCL/PMC/SR/RD/PP/19
31	STA:2+000 TO 2+500 PLAN/PROFILE BADKHAL ROAD	FSCL/PMC/SR/RD/PP/20
32	STA:2+500 TO 3+000 PLAN/PROFILE BADKHAL ROAD	FSCL/PMC/SR/RD/PP/21
33	STA:3+000 TO 3+350 PLAN/PROFILE BADKHAL ROAD	FSCL/PMC/SR/RD/PP/22
34	STA: 0+000 TO 0+500 AMBEDKAR MARG	FSCL/PMC/SR/RD/PP/23

List of Drawings		
Sl.No.	Drawing Title	Drawing No.
35	STA: 0+500 TO 1+000 AMBEDKAR MARG	FSCL/PMC/SR/RD/PP/24
36	STA: 1+000 TO 1+500 AMBEDKAR MARG	FSCL/PMC/SR/RD/PP/25
37	STA: 1+500 TO 1+950 AMBEDKAR MARG	FSCL/PMC/SR/RD/PP/26
38	PROPOSED UTILITY PLAN (AMBEDKAR ROAD)	FSCL/PMC/SR/UT-01
39	PROPOSED UTILITY PLAN (BADKHAL CHOWK-ANKHEER CHOWK-BADKHAL MOR CHOWK)	FSCL/PMC/SR/UT-02
40	UTILITY PLAN LAYOUT (INTERNAL ROAD SEC 19, TALAB ROAD AND LINK ROAD)	FSCL/PMC/SR/UT-03
41	PROPOSED ELECTRICAL PLAN (TALAB ROAD)	FSCL/PMC/SR/RD/EL-04
42	PROPOSED ELECTRICAL PLAN (TALAB ROAD)	FSCL/PMC/SR/RD/EL-05
43	PROPOSED ELECTRICAL PLAN (TALAB ROAD)(SECTOR 19 INTERNAL ROAD 1-1)	FSCL/PMC/SR/RD/EL-06
44	PROPOSED ELECTRICAL PLAN (TALAB ROAD)(SECTOR 19 INTERNAL ROAD 1-2)	FSCL/PMC/SR/RD/EL-07
45	PROPOSED ELECTRICAL PLAN (TALAB ROAD)(SECTOR 19 INTERNAL ROAD 1-2)	FSCL/PMC/SR/RD/EL-08
46	PROPOSED ELECTRICAL PLAN (TALAB ROAD)(SECTOR 19 INTERNAL ROAD 2)	FSCL/PMC/SR/RD/EL-09
47	PROPOSED ELECTRICAL PLAN (TALAB ROAD)(SECTOR 19 INTERNAL ROAD 2)	FSCL/PMC/SR/RD/EL-10
48	PROPOSED ELECTRICAL PLAN (TALAB ROAD)(SECTOR 19 INTERNAL ROAD 2)	FSCL/PMC/SR/RD/EL-11
49	SIGNAGE PLAN STA: 0+000 TO 0+300 AMBEDKAR MARG	FSCL/PMC/SR/RD/SG/-01
50	SIGNAGE PLAN STA: 0+300 TO 0+700 AMBEDKAR MARG	FSCL/PMC/SR/RD/SG/-02
51	SIGNAGE PLAN STA: 0+700 TO 1+100 AMBEDKAR MARG	FSCL/PMC/SR/RD/SG/-03
52	SIGNAGE PLAN STA: 1+100 TO 1+500 AMBEDKAR MARG	FSCL/PMC/SR/RD/SG/-04
53	SIGNAGE PLAN STA: 1+500 TO 1+995 AMBEDKAR MARG	FSCL/PMC/SR/RD/SG/-05
54	SIGNAGE PLAN STA: 0+000 TO 0+300 BADKHAL ROAD	FSCL/PMC/SR/RD/SG/-16
55	SIGNAGE PLAN STA: 0+300 TO 0+700 BADKHAL ROAD	FSCL/PMC/SR/RD/SG/-17
56	SIGNAGE PLAN STA: 0+700 TO 1+100 BADKHAL ROAD	FSCL/PMC/SR/RD/SG/-18
57	SIGNAGE PLAN STA: 1+100 TO 1+500 BADKHAL ROAD	FSCL/PMC/SR/RD/SG/-19
58	SIGNAGE PLAN STA: 1+500 TO 1+900 BADKHAL ROAD	FSCL/PMC/SR/RD/SG/-20
59	SIGNAGE PLAN STA: 1+900 TO 2+300 BADKHAL ROAD	FSCL/PMC/SR/RD/SG/-21
60	SIGNAGE PLAN STA: 2+300 TO 2+700 BADKHAL ROAD	FSCL/PMC/SR/RD/SG/-22
61	SIGNAGE PLAN STA: 2+700 TO 3+100 BADKHAL ROAD	FSCL/PMC/SR/RD/SG/-23
62	SIGNAGE PLAN STA: 3+100 TO 3+345 BADKHAL ROAD	FSCL/PMC/SR/RD/SG/-24
63	SIGNAGE PLAN STA: 0+000 TO 0+380 TALAB ROAD	FSCL/PMC/SR/RD/SG/-06
64	SIGNAGE PLAN STA: 0+380 TO 0+780 TALAB ROAD	FSCL/PMC/SR/RD/SG/-07
65	SIGNAGE PLAN STA: 0+780 TO 1+180 TALAB ROAD, SIGNAGE PLAN STA: 0+000 TO 0+500 LINK ROAD	FSCL/PMC/SR/RD/SG/-08
66	SIGNAGE PLAN STA: 1+180 TO 1+450 TALAB ROAD, SIGNAGE PLAN STA: 0+500 TO 0+700 LINK ROAD	FSCL/PMC/SR/RD/SG/-09
67	SIGNAGE PLAN STA: 0+000 TO 0+387 SECTOR-19 INTERNAL ROAD 1-1	FSCL/PMC/SR/RD/SG/-10
68	SIGNAGE PLAN STA: 0+000 TO 0+400 SECTOR-19 INTERNAL ROAD 1-2	FSCL/PMC/SR/RD/SG/-11
69	SIGNAGE PLAN STA: 0+000 TO 0+603 SECTOR-19 INTERNAL ROAD 1-2	FSCL/PMC/SR/RD/SG/-12
70	SIGNAGE PLAN STA: 0+000 TO 0+375 SECTOR-19 INTERNAL ROAD 2	FSCL/PMC/SR/RD/SG/-13
71	SIGNAGE PLAN STA: 0+375 TO 0+675 SECTOR-19 INTERNAL ROAD 2	FSCL/PMC/SR/RD/SG/-14
72	SIGNAGE PLAN STA: 0+375 TO 0+675 SECTOR-19 INTERNAL ROAD 2	FSCL/PMC/SR/RD/SG/-15
73	EXISTING AND PROPOSED CROSS SECTION (ROAD 1)	FSCL/PMC/SR/CS-01
74	EXISTING AND PROPOSED CROSS SECTION (SECTOR 21 D ROAD)	FSCL/PMC/SR/CS-02

List of Drawings		
Sl.No.	Drawing Title	Drawing No.
75	EXISTING AND PROPOSED CROSS SECTION (SECTOR 21 D ROAD)	FSCL/PMC/SR/CS-03
76	EXISTING AND PROPOSED CROSS SECTION (SECTOR 21 B ROAD)	FSCL/PMC/SR/CS-04
77	EXISTING AND PROPOSED CROSS SECTION (ITI ROAD)	FSCL/PMC/SR/CS-05
78	EXISTING AND PROPOSED CROSS SECTION (ITI ROAD)	FSCL/PMC/SR/CS-06
79	EXISTING AND PROPOSED CROSS SECTION (MAIN BANDH ROAD)	FSCL/PMC/SR/CS-07
80	EXISTING AND PROPOSED CROSS SECTION (MAIN BANDH ROAD)	FSCL/PMC/SR/CS-08
81	EXISTING AND PROPOSED CROSS SECTION (ROAD NO 2)	FSCL/PMC/SR/CS-09
82	EXISTING AND PROPOSED CROSS SECTION (JIVA MARG)	FSCL/PMC/SR/CS-10
83	EXISTING AND PROPOSED CROSS SECTION (RAILWAY ROAD)	FSCL/PMC/SR/CS-11
84	EXISTING AND PROPOSED CROSS SECTION (SHAHEED BHAGAT SINGH ROAD)	FSCL/PMC/SR/CS-12
85	EXISTING AND PROPOSED CROSS SECTION (BARAHI TALAB)	FSCL/PMC/SR/CS-13
86	EXISTING AND PROPOSED CROSS SECTION (MAIN BANDH ROAD)	FSCL/PMC/SR/CS-14
87	EXISTING AND PROPOSED CROSS SECTION (NH 44 SERVICE ROAD)	FSCL/PMC/SR/CS-15
88	EXISTING AND PROPOSED CROSS SECTION (NH 44 SERVICE ROAD)	FSCL/PMC/SR/CS-16
89	EXISTING AND PROPOSED CROSS SECTION (STATION ROAD)	FSCL/PMC/SR/CS-17
90	EXISTING AND PROPOSED CROSS SECTION (20 A STATION ROAD)	FSCL/PMC/SR/CS-18
91	DETAILS OF INTERSECTION AT CH. 00+000 (ROAD 21 D AT GRADE INTERSECTION)	FSCL/PMC/SR/RD/INT.-01
92	DETAILS OF INTERSECTION AT CH. 00+000 (ROAD 1 AT GRADE INTERSECTION)	FSCL/PMC/SR/RD/INT.-02
93	DETAILS OF INTERSECTION AT CH. 00+000 (ROAD 2 AT GRADE INTERSECTION)	FSCL/PMC/SR/RD/INT.-03
94	DETAILS OF INTERSECTION AT CH. 00+000 (JIVA ROAD AT GRADE INTERSECTION)	FSCL/PMC/SR/RD/INT.-04
95	DETAILS OF INTERSECTION AT CH. 01+636 (ROAD 21 D AT GRADE INTERSECTION)	FSCL/PMC/SR/RD/INT.-05
96	DETAILS OF INTERSECTION AT CH. 01+636 (RAILWAY ROAD 20 A AT GRADE INTERSECTION)	FSCL/PMC/SR/RD/INT.-06
97	DETAILS OF INTERSECTION AT CH. 00+680 (ROAD 21 D AT GRADE INTERSECTION)	FSCL/PMC/SR/RD/INT.-07
98	DETAILS OF INTERSECTION AT CH. 00+000 (NEELAM CHOWK AT GRADE INTERSECTION)	FSCL/PMC/SR/RD/INT.-08
99	DETAILS OF INTERSECTION AT CH. 00+000 (SBS CHOWK AT GRADE INTERSECTION)	FSCL/PMC/SR/RD/INT.-09
100	STA:00+000 TO 00+500 PLAN/PROFILE SERVICE ROAD (LHS)	FSCL/PMC/SR/RD/PP/-01
101	STA:00+500 TO 01+000 PLAN/PROFILE SERVICE ROAD (LHS)	FSCL/PMC/SR/RD/PP/-02
102	STA:01+000 TO 01+500 PLAN/PROFILE SERVICE ROAD (LHS)	FSCL/PMC/SR/RD/PP/-03
103	STA:01+500 TO 01+640 PLAN/PROFILE SERVICE ROAD (LHS)	FSCL/PMC/SR/RD/PP/-04
104	STA:00+000 TO 00+500 PLAN/PROFILE SERVICE ROAD (RHS)	FSCL/PMC/SR/RD/PP/-01
105	STA:00+500 TO 01+000 PLAN/PROFILE SERVICE ROAD (RHS)	FSCL/PMC/SR/RD/PP/-02
106	STA:01+000 TO 01+500 PLAN/PROFILE SERVICE ROAD (RHS)	FSCL/PMC/SR/RD/PP/-03
107	STA:01+500 TO 01+840 PLAN/PROFILE SERVICE ROAD (RHS)	FSCL/PMC/SR/RD/PP/-04
108	STA:00+075 TO 00+400 PLAN/PROFILE SERVICE ROAD (RHS)	FSCL/PMC/SR/RD/PP/-01
109	STA: 00+000 TO 01+000 PLAN/PROFILE ITI & SHAHEED BHAGAT SINGH	FSCL/PMC/SR/RD/PP/-01
110	STA: 01+000 TO 02+000 PLAN/PROFILE ITI & SHAHEED BHAGAT SINGH	FSCL/PMC/SR/RD/PP/-02

List of Drawings		
Sl.No.	Drawing Title	Drawing No.
111	STA: 02+000 TO 03+000 PLAN/PROFILE ITI & SHAHEED BHAGAT SINGH	FSCL/PMC/SR/RD/PP/-03
112	STA: 03+000 TO 03+500 PLAN/PROFILE ITI & SHAHEED BHAGAT SINGH	FSCL/PMC/SR/RD/PP/-04
113	STA:0+000 TO 0+500 PLAN/PROFILE JIVA ROAD	FSCL/PMC/SR/RD/PP/-01
114	STA:0+500 TO 01+000 PLAN/PROFILE JIVA ROAD	FSCL/PMC/SR/RD/PP/-02
115	STA:01+000 TO 01+150 PLAN/PROFILE JIVA ROAD	FSCL/PMC/SR/RD/PP/-03
116	STA:0+000 TO 0+500 PLAN/PROFILE MAIN BANDH ROAD	FSCL/PMC/SR/RD/PP/-01
117	STA:0+500 TO 01+000 PLAN/PROFILE MAIN BANDH ROAD	FSCL/PMC/SR/RD/PP/-02
118	STA:01+000 TO 01+250 PLAN/PROFILE MAIN BANDH ROAD	FSCL/PMC/SR/RD/PP/-03
119	STA: 00+000 TO 00+500 PLAN/PROFILE NH 44 SERVICE ROAD	FSCL/PMC/SR/RD/PP/-01
120	STA: 0+500 TO 1+000 PLAN/PROFILE NH 44 SERVICE ROAD	FSCL/PMC/SR/RD/PP/-02
121	STA: 1+000 TO 1+500 PLAN/PROFILE NH 44 SERVICE ROAD	FSCL/PMC/SR/RD/PP/-03
122	STA: 1+500 TO 2+000 PLAN/PROFILE NH 44 SERVICE ROAD	FSCL/PMC/SR/RD/PP/-04
123	STA: 2+000 TO 2+500 PLAN/PROFILE NH 44 SERVICE ROAD	FSCL/PMC/SR/RD/PP/-05
124	STA: 2+500 TO 3+000 PLAN/PROFILE NH 44 SERVICE ROAD	FSCL/PMC/SR/RD/PP/-06
125	STA: 3+000 TO 3+340 PLAN/PROFILE NH 44 SERVICE ROAD	FSCL/PMC/SR/RD/PP/-07
126	STA:0+000 TO 0+500 PLAN/PROFILE RAILWAY ROAD	FSCL/PMC/SR/RD/PP/-01
127	STA:00+500 TO 00+950 PLAN/PROFILE RAILWAY ROAD	FSCL/PMC/SR/RD/PP/-02
128	STA:00+000 TO 00+500 PLAN/PROFILE ROAD NO. 1	FSCL/PMC/SR/RD/PP/-01
129	STA:00+500 TO 00+600 PLAN/PROFILE ROAD NO. 1	FSCL/PMC/SR/RD/PP/-02
130	STA:00+000 TO 00+500 PLAN/PROFILE ROAD NO. 2	FSCL/PMC/SR/RD/PP/-01
131	STA:00+500 TO 01+000 PLAN/PROFILE ROAD NO. 2	FSCL/PMC/SR/RD/PP/-02
132	STA:00+000 TO 00+500 PLAN/PROFILE ROAD 21 B	FSCL/PMC/SR/RD/PP/-01
133	STA:00+500 TO 01+000 PLAN/PROFILE ROAD 21 B	FSCL/PMC/SR/RD/PP/-02
134	STA:01+000 TO 01+500 PLAN/PROFILE ROAD 21 B	FSCL/PMC/SR/RD/PP/-03
135	STA:01+500 TO 01+680 PLAN/PROFILE ROAD 21 B	FSCL/PMC/SR/RD/PP/-04
136	STA:00+000 TO 00+500 PLAN/PROFILE ROAD 21 D	FSCL/PMC/SR/RD/PP/-01
137	STA:00+500 TO 01+000 PLAN/PROFILE ROAD 21 D	FSCL/PMC/SR/RD/PP/-02
138	STA:01+000 TO 01+500 PLAN/PROFILE ROAD 21 D	FSCL/PMC/SR/RD/PP/-03
139	STA:01+500 TO 01+636 PLAN/PROFILE ROAD 21 D	FSCL/PMC/SR/RD/PP/-04
140	STA:00+000 TO 00+500 PLAN/PROFILE SECTOR 20 STATION ROAD	FSCL/PMC/SR/RD/PP/-01
141	STA:00+500 TO 00+875 PLAN/PROFILE SECTOR 20 STATION ROAD	FSCL/PMC/SR/RD/PP/-02
142	COMBINED LAYOUT PLAN OF SEWER, WATER SUPPLY AND STORM WATER	FSCL/PMC/SR/UP/WU/-01
143	LAYOUT PLAN OF SEWER	FSCL/PMC/SR/UP/WU/-02
144	LAYOUT PLAN OF STORM WATER LINE	FSCL/PMC/SR/UP/WU/-04
145	LAYOUT PLAN OF WATER SUPPLY	FSCL/PMC/SR/UP/WU/-03
146	COMBINED LAYOUT PLAN OF SEWER, WATER SUPPLY AND STORM WATER (BARAHI TALAB)	FSCL/PMC/SR/UP/WU/-05
147	UTILITY LAYOUT PLAN OF STATION ROAD	FSCL/PMC/SR/UP/WU/-08
148	LAYOUT PLAN OF SEWER, WATER SUPPLY AND STORM WATER DRAIN	FSCL/PMC/SR/UP/WU/-07
149	TYPICAL DRAIN DETAIL	FSCL/PMC/SR/UP/WU/-09
150	TYPICAL ARRANGEMENT OF ACCESS MAINHOLE	FSCL/PMC/SR/UP/WU/-10
151	TYPICAL SECTIONS SEWER MAINHOLE	FSCL/PMC/SR/UP/WU/-11
152	TYPICAL ARRANGEMENT OF INLET CHAMBER	FSCL/PMC/SR/UP/WU/-12
153	TYPICAL DETAIL OF SECTOR STORM WATER DRAIN CONNECTION TO MAIN SWD CHANNEL 1	FSCL/PMC/SR/UP/WU/-13
154	TYPICAL DETAIL OF WATER SUPPLY TAPPING	FSCL/PMC/SR/UP/WU/-14
155	TYPICAL DETAIL OF SECTOR STORM WATER DRAIN CONNECTION TO MAIN SWD CHANNEL 2	FSCL/PMC/SR/UP/WU/-15
156	ELECTRICAL PLAN (ROAD NO.1)	FSCL/PMC/SR/UP/EU/-01
157	ELECTRICAL PLAN (ROAD NO.21 B)	FSCL/PMC/SR/UP/EU/-02
158	ELECTRICAL PLAN (ROAD NO.21 B)	FSCL/PMC/SR/UP/EU/-03

List of Drawings		
Sl.No.	Drawing Title	Drawing No.
159	ELECTRICAL PLAN (JIVA ROAD)	FSCL/PMC/SR/UP/EU/-04
160	ELECTRICAL PLAN (RAILWAY ROAD)	FSCL/PMC/SR/UP/EU/-05
161	ELECTRICAL PLAN (SECTOR 20 STATION ROAD)	FSCL/PMC/SR/UP/EU/-06
162	SIGNAGE PLAN STA: 00+000 TO 00+700 SECTOR 21 B ROAD	FSCL/PMC/SR/RD/SG-01
163	SIGNAGE PLAN STA: 00+700 TO 01+400 SECTOR 21 B ROAD	FSCL/PMC/SR/RD/SG-02
164	SIGNAGE PLAN STA: 01+400 TO 01+685 SECTOR 21 B ROAD	FSCL/PMC/SR/RD/SG-03
165	SIGNAGE PLAN STA: 00+000 TO 00+740 SECTOR 21 D ROAD	FSCL/PMC/SR/RD/SG-01
166	SIGNAGE PLAN STA: 00+740 TO 01+460 SECTOR 21 D ROAD	FSCL/PMC/SR/RD/SG-02
167	SIGNAGE PLAN STA: 01+460 TO 01+635 SECTOR 21 D ROAD	FSCL/PMC/SR/RD/SG-03
168	SIGNAGE PLAN STA: 00+000 TO 00+700 JIVA MARG	FSCL/PMC/SR/RD/SG-01
169	SIGNAGE PLAN STA: 00+700 TO 01+150 JIVA MARG	FSCL/PMC/SR/RD/SG-02
170	SIGNAGE PLAN STA: 00+000 TO 00+740 MAIN BANDH ROAD	FSCL/PMC/SR/RD/SG-01
171	SIGNAGE PLAN STA: 00+740 TO 01+247 MAIN BANDH ROAD	FSCL/PMC/SR/RD/SG-02
172	SIGNAGE PLAN STA: 00+000 TO 00+760 RAILWAY ROAD	FSCL/PMC/SR/RD/SG-01
173	SIGNAGE PLAN STA: 00+760 TO 00+950 RAILWAY ROAD	FSCL/PMC/SR/RD/SG-02
174	SIGNAGE PLAN STA: 00+000 TO 00+575 ROAD NO I	FSCL/PMC/SR/RD/SG-01
175	SIGNAGE PLAN STA: 00+000 TO 00+800 ROAD NO II	FSCL/PMC/SR/RD/SG-01
176	SIGNAGE PLAN STA: 00+800 TO 01+000 ROAD NO II	FSCL/PMC/SR/RD/SG-02
177	SIGNAGE PLAN STA: 00+000 TO 00+889 SECTOR 20 STATION ROAD	FSCL/PMC/SR/RD/SG-01
178	MISCELLANEOUS DETAILS INTERSECTION (TYPICAL)	FSCL/PMC/SR/RD/MD/01
179	MISCELLANEOUS DETAILS BUS BAYS (2 LANE)	FSCL/PMC/SR/RD/MD/02
180	MISCELLANEOUS DETAILS BUS BAYS (4 LANE)	FSCL/PMC/SR/RD/MD/03
181	MISCELLANEOUS DETAILS TRANSITION/ SPEED BUMP/ PARKING LANE/ RUMBLE STRIPS	FSCL/PMC/SR/RD/MD/04
182	MISCELLANEOUS DETAILS KERB/ MEDIAN DETAILS	FSCL/PMC/SR/RD/MD/05
183	MISCELLANEOUS DETAILS MEDIAN & ISLAND END TREATMENT	FSCL/PMC/SR/RD/MD/06
184	MISCELLANEOUS DETAILS GUIDERAIL (SINGLE-BEAM CRASH BARRIER)	FSCL/PMC/SR/RD/MD/07
185	MISCELLANEOUS DETAILS OF PAVER BLOCK AND TACTILE BLOCK	FSCL/PMC/SR/RD/MD/08
186	MISCELLANEOUS DETAILS ROAD SIGNS-1	FSCL/PMC/SR/RD/MD/09A
187	MISCELLANEOUS DETAILS ROAD SIGNS-2	FSCL/PMC/SR/RD/MD/09B
188	MISCELLANEOUS DETAILS ROAD SIGNS-3	FSCL/PMC/SR/RD/MD/09C
189	MISCELLANEOUS DETAILS ROAD SIGNS-2	FSCL/PMC/SR/RD/MD/10
190	MISCELLANEOUS DETAILS ROAD SIGNS-4	FSCL/PMC/SR/RD/MD/10A
191	MISCELLANEOUS DETAILS ROAD SIGNS-5	FSCL/PMC/SR/RD/MD/10B
192	MISCELLANEOUS DETAILS ROAD SIGNS-6	FSCL/PMC/SR/RD/MD/10C
193	MISCELLANEOUS DETAILS ROAD SIGNS-3	FSCL/PMC/SR/RD/MD/11
194	MISCELLANEOUS DETAILS ROAD SIGNS-7	FSCL/PMC/SR/RD/MD/11A
195	MISCELLANEOUS DETAILS ROAD SIGNS-8	FSCL/PMC/SR/RD/MD/11B
196	MISCELLANEOUS DETAILS ROAD SIGNS-9	FSCL/PMC/SR/RD/MD/11C
197	MISCELLANEOUS DETAILS PEDESTRIANS GUARD RAIL AT FOOTPATH ON ROAD SIDE	FSCL/PMC/SR/RD/MD/12
198	MISCELLANEOUS DETAILS RAISED PEDESTRIANS CROSSING AT MEDIAN	FSCL/PMC/SR/RD/MD/13
199	MISCELLANEOUS DETAILS ZEBRA CROSSING AT MEDIAN	FSCL/PMC/SR/RD/MD/14
200	MISCELLANEOUS DETAILS TRAFFIC CONTROL AND SAFETY DEVICES PROVISIONS FOR T INTERSECTION (TYPICAL)	FSCL/PMC/SR/RD/MD/15
201	MISCELLANEOUS DETAILS TRAFFIC CONTROL AND SAFETY DEVICES PROVISIONS FOR CROSS INTERSECTION (TYPICAL)	FSCL/PMC/SR/RD/MD/16
202	MISCELLANEOUS DETAILS PAVEMENT MARKING-1	FSCL/PMC/SR/RD/MD/17
203	MISCELLANEOUS DETAILS PAVEMENT MARKING-2	FSCL/PMC/SR/RD/MD/18
204	MISCELLANEOUS DETAILS PAVEMENT MARKING-3A RUMBLE STRIPS & ROAD HUMP ROAD STUDS	FSCL/PMC/SR/RD/MD/19
205	MISCELLANEOUS DETAILS PAVEMENT MARKING-3B	FSCL/PMC/SR/RD/MD/20

List of Drawings		
Sl.No.	Drawing Title	Drawing No.
206	MISCELLANEOUS DETAILS PAVEMENT MARKING-4	FSCL/PMC/SR/RD/MD/21
207	MISCELLANEOUS DETAILS LANE MARKING URBAN AND RURAL AREA	FSCL/PMC/SR/RD/MD/22
208	MISCELLANEOUS DETAILS OF ARROW, LETTER MARKING	FSCL/PMC/SR/RD/MD/23
209	MISCELLANEOUS DETAILS SAFETY IN ROAD CONSTRUCTION ZONES-1	FSCL/PMC/SR/RD/MD/24
210	MISCELLANEOUS DETAILS SAFETY IN ROAD CONSTRUCTION ZONES-2	FSCL/PMC/SR/RD/MD/25
211	MISCELLANEOUS DETAILS STREET PARKING	FSCL/PMC/SR/RD/MD/26
212	MISCELLANEOUS DETAILS K ERB RAMP DETAILS	FSCL/PMC/SR/RD/MD/27
213	CYCLE TRACK DETAIL	FSCL/PMC/SR/RD/MD/28
214	CYCLE TRACK DETAIL	FSCL/PMC/SR/RD/MD/29
215	PLANTER/ SEATER/CYCLE RACK	FSCL/PMC/SR/RD/MD/30
216	BUS STOP	FSCL/PMC/SR/RD/MD/31
217	PUBLIC CONVENIENCES DETAIL	FSCL/PMC/SR/RD/MD/32

7.2. GOVERNING DESIGN PARAMETERS FOR CONSTRUCTION

All designs shall confirm to the various standards & codes as under:

1. Space Standard for Roads in Urban Areas (IRC:69-1977)
2. Guidelines on Road Drainage (IRC SP 42:2014)
3. Bureau of Indian Standards
4. Plain and Reinforce Concrete: Code of Practice IS: 456-2008
5. Design Aids for Reinforced Concrete SP-16
6. Handbook on Concrete Reinforcement and Detailing SP-34

The above list is indicative. Other codes/standards may also be required to be adopted. In such cases, the same shall be adopted upon approved from the Authority (the FSCL)

7.3. Approval of design mix for RCC: On approval of the tender, Bidder is required to arrange all for approval of design mix of RCC from any of the Indian Institute of Technology or National Institute of Technology or NABL accredited Laboratories.

7.3.1. Materials of construction of proposed Smart Road shall be governed by the relevant Indian Standards Codes of Practice.

7.3.2. The design procedure permissible stresses in material and other relevant stipulations shall be governed by the codes of practice published by BIS and other relevant IS codes.

7.3.3. New Codes of Practice and amendments issued by the Bureau of Indian standards till the date of tender will also be automatically applicable for the work, similarly amendments and revisions. Specifications made up to the date of tender shall also be applicable.

7.4. Testing of concrete: All concrete used in the RCC structure shall be mixed in power driven mechanical mixers and vibrated. The Bidder's unit Rate shall include the cost of testing of concrete cubes. Installation of a Calibrated Testing Machine at site by the Bidder will be acceptable. The testing will however, be done under the supervision of the Engineer-in-charge or his authorized representative. The Bidder shall finish a test certificate of the concrete test machine, to be used by him on the site of works sampling, strength test of concrete and acceptance criteria shall be in accordance with IS Codes.

- 7.5. Finish of concrete surface: Good surface of the exposed reinforced concrete members must be ensured by the Bidder by using plane and true to shape form work. Corrections of defects must be done as desired by the Engineer-in-charge. Tolerance in form work shall be in accordance with IS Codes.
- 7.6. Size of Aggregate: Size of aggregate to be used in plain concrete, RCC concrete structure shall be in accordance with specifications. However, for sections of structural components of 300 mm thickness and less only 20mm and downgraded aggregate shall be used.
- 7.7. Model Rules relating to labour, Water Supply & Sanitation in Labour Camps are given in ANNEXURE - A.

1.1. SCOPE OF WORK & GENERAL SPECIFICATIONS

About the Smart Roads – Phase-1:

- a) Ambedkar road is a 4-lane divided road extending over a total length of 1.97 kms from Rajiv Chowk to By-Pass Road.
- b) Talab Road has a varying lane configuration, the stretch between the link road junction to Sector-19 internal road is a 2-lane undivided road and the rest is a 4-lane divided road.
- c) The internal roads identified for improvement comprises of Link road-section connected to Talab Road and internal roads within Sector -19 connecting Badkhal road to Ambedkar Marg via DPS School. All the identified road sections have similar lane configuration of i.e. 2-lane undivided road with varying RoW.
- d) The road section from Badkhal Mor to Badkhal Chowk via. Ankheer Chowk has similar lane configuration of 4-lane divided carriageway, which extends over a total length of 3.33 kms.
- e) The right-of-way close to the Bypass on Ambedkar Marg includes several encroachments.
- f) The abutting land uses on Ambedkar Marg, Talab road and Sector 19 roads are residential and commercial, whereas Badkhal road has residential and Institutional land uses.
- g) The cross section for the smart roads was determined based on traffic studies.
- h) All roads are proposed to have pedestrian footpath and cycle track. Wherever the space constraints exists, a shared space for both are proposed.
- i) On Badkhal road 3.0 m wide cycle track is proposed in green zone on existing 2.4 m wide drain cover. Therefore drain cover needs to be widened to accommodate cycle track.
- j) Vending zones are proposed on Talab road and Link roads.
- k) On Talab road parking facilities are provided on the stretch nearer to Ambedkar Road and Badkhal Smart road. Few more parking lots are planned along Link Road.
- l) Raised pedestrian crossings are proposed to facilitate pedestrians to cross the road.
- m) For details on existing and proposed components, please refer to appropriate sections, Plans and drawings.

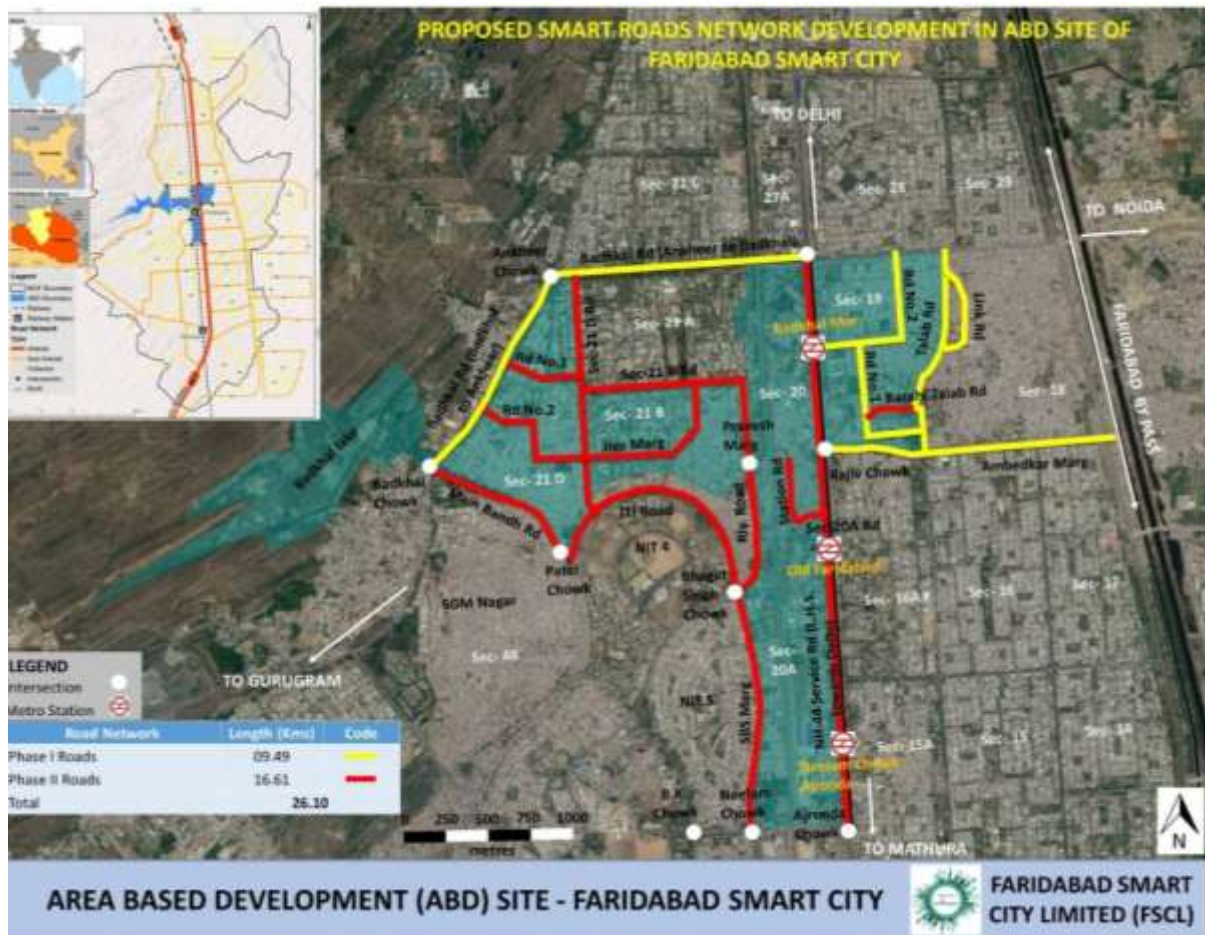

About the Smart Roads – Phase-II:

- a. Main Bandh road comprises of two lane undivided road section from Badkhal Chowk to Patel Chowk passing through dense residential area has a varying RoW 20-45 m, It extends over length of 1.22 kms.
- b. ITI road comprises of road section around new Industrial township in Sector 21-B. The stretch passes through dense residential area and is main connectivity to Faridabad Railway Station. It is a two lane undivided road of 1.8 km is between Patel chowk and Bhagat Singh chowk with three access roads.
- c. Railway Road and Sec 20 A- Station Road, which are the major roads connecting to Faridabad Railway Station. These roads are 2 lane undivided road with varying RoW of 10-20 meters. The Railway Road comprises a section of 0.91 kms and the Sec 20A- Station road comprises a section of 1.20 kms. The Railway Road crosses through Gandhi colony on one side and Faridabad Railway Station on the other.
- d. Sector 21 internal roads comprises of Sector-21D road connecting Badkhal Road and ITI road, Sector-21B Road, Jiva Marg, Road No.1 and Road No.2 connecting Badkhal Road to Sector-21D Road. Sector-21D road and Sector-21B road have lane configuration of 2 lane divided road with service road on both side, others are 2-lane undivided road. The total length of these sections comprises of 6.05 kms. These roads act as access roads for residential areas of Sector-21. These roads are classified as local roads based on its functionality as it provides accessibility to residential areas of Sector-21.

- e. Shaheed Bhagat Singh Marg is of length 1.63 km. The road is an important road connecting NIT blocks with mainly Old Faridabad Railway Station and rest of the Faridabad. It is a 4 lane divided road running parallel with NH-44 and Railway line.
- f. Barahi Talab road section is parallel to Sec-19 Internal road-2. It is a two lane undivided road of 0.35 km is connecting Talab Road and Sec-19 Internal Road 2.
- g. The 3.8 km stretch from Badkhal Mor to Ajronda Chowk is a part of Delhi-Agra National Highway (NH)-44, which acts a spine to transfer the northbound traffic to south and vice-versa. This stretch is a 6-lane divided road along with service road. The scope as part of Phase II is service road of width 8 meters.
- h. The cross section for the smart roads was determined based on traffic studies.
- i. All roads are proposed to have pedestrian footpath and cycle track. Wherever the space constraints exists, a shared space for both are proposed.
- j. Vending zones are proposed on Main Bandh road, Barahi Talab and Shaheed Bhagat Singh Marg.
- k. On Main Bandh road, ITI road, Shaheed Bhagat Singh Marg, Railway Road, parking facilities have been provided.
- l. Raised pedestrian crossings are proposed to facilitate pedestrians to cross the road.
- m. For details on existing and proposed components, please refer to appropriate sections, Plans and drawings.

1.2. General Information:

1. The broad scope of work for Phase-I, Smart roads includes construction of cycle tracks and footpaths on Ambedkar road, Sector 19 internal roads, Talab road, Link road and Badkhal road.
2. The broad scope of work for Phase-II, Smart roads includes construction of cycle tracks and footpaths on Sector 21D road, Sector 21B road, Sector 21D road no:1 & 2, Jiva Marg, Main Bandh road, ITI road, Shaheed Bhagat Singh Marg, Railway road, Station road and NH service road.
3. The following are the major intersections on Phase-I, Smart roads
 - a. Ambedkar Marg:**
 - (i) Rajiv Chowk
 - (ii) Lala Lajpat Rai Junction
 - (iii) Parashar Marg Junction
 - (iv) Bypass road Junction
 - b. Talab road**
 - (i) Staggered intersection near Barahi Talab
 - (ii) Intersection at Talab & Link Road (near Rotary Public School)
 - (iii) Intersection at Talab & Link Road (near Badkhal Smart Road)
 - c. Badkhal Road:**
 - (i) Ankheer Chowk
 - (ii) Badkhal Chowk
4. The following are the major intersections on Phase-II, Smart roads
 - d. ITI road:**

(i) Patel Chowk

e. Shaheed Bhagat Singh Marg

(i) Bhagat Singh Chowk

(ii) Neelam chowk

f. Railway Road:

(i) Pravesh Marg roundabout

(ii) Badkhal Chowk

g. Railway Road:

(i) Bhadkal Mor Chowk

(ii) Rajiv Chowk

(iii) Ajronda Chowk

1.3. Broad Scope of Work

- i. Dismantling of existing Infrastructure including structures, Gantry, Sign Boards, encroachments, electrical overhead wiring, poles, transformers, etc.
- ii. Replantation of trees.
- iii. Dispose of the dismantled materials to the location indicated by the FSCL.
- iv. Handover or stack the dismantled material that can be reused.
- v. Shifting of the underground infrastructure including the OFC, Gas pipes, Water supply etc will be done by the relevant agency. The Bidder needs to have the approval for shifting of the utilities from the relevant agency and FSCL.
- vi. In case, the bidder is required to shift any of the utilities, the cost of shifting shall be paid by the FSCL. However, prior approval shall be taken from the FSCL.
- vii. Phase-I roads: Construction of a uniform 7.5 metres carriageway on either sides of Ambedkar Marg, Badkhal Road 7 metres on Sector 19 roads and Talab Road. The existing carriageway on Badkhal Road is to be retained.
- viii. Laying of Concrete Pavement in Ambedkar Road.
- ix. Overlaying of Bituminous layer on Badkhal Mor to Ankheer chowk road.
- x. Phase-II roads: The existing carriageway of all roads will be retained except Main Bandh road to be widened and partly 4 lane in ITI road.
- xi. Construction of Footpaths
- xii. Construction of Cycle Tracks
- xiii. Construction of Intersections/Raised Pedestrian Crossings.
- xiv. Providing Landscaping including the street furniture, tiling, grating, painting etc
- xv. Providing Road Signage Boards including signage markings
- xvi. Construction of 100, 150, 250 and 300 mm DI water supply system.
- xvii. Constructions of Storm water system including provision of concrete rectangular box culvert section duct.
- xviii. Construction of RCC duct with cable trays with supports.

- xix. Foundation for Transformers, Sub Stations, Poles, Feeder Pillars, Service Feeder Pillars etc.
- xx. Supply and Laying of Pipes for Road Crossings.
- xxi. Provision of Earthing system
- xxii. Supply and Laying of underground LT/HT cables in duct/crossing pipes including but not limited to street lighting/ Landscaping/footpaths/cycle track etc.
- xxiii. Provision of LT cable for Kiosks.
- xxiv. Supply, Installation, Testing and Commissioning of H Poles with all accessories, LT/HT cables, Transformer, RMU, Compact Switch Gear, Feeder pillars, Service Feeder pillar, Termination of Cables with termination kit.
- xxv. Operation and Maintenance of all the above-indicated works for five years.

Provisional Items: A provisional sum for repairing of concrete pavement is considered against the following items, which are not considered in the bid price. The Bidder needs to quote the prices for the following items (Item detail description shall be considered as per B.O.Q.) that are not considered in the bid price

- a. Providing, mixing and applying bonding coat of approved adhesive on chipped portion of RCC
- b. Epoxy bonding adhesive having coverage 2.20 sqm/kg of approved make
- c. Providing, mixing and applying SBR polymer (of approved make) modified Cement mortar-12 mm average thickness.
- d. Providing, mixing and applying SBR polymer (of approved make) modified Cement -25 mm average thickness in 2 layers.
- e. Providing, mixing and applying SBR polymer (of approved make) modified Cement mortar -50 mm average thickness in 3 layers.
- f. Providing, mixing and applying SBR polymer (of approved make @ minimum 2% by wt. of cement used) modified plain/reinforced cement concrete for structural members having minimum characteristic compressive strength -25 mm thick in Grade M 25 with cement content not less than 330 kg per cum
- g. Providing, mixing and applying SBR polymer (of approved make @ minimum 2% by wt. of cement used) modified plain/reinforced cement concrete for structural members having minimum characteristic compressive strength -50mm thick in Grade M 25 with cement content not less than 330 kg per cum
- h. Providing, mixing and applying SBR polymer (of approved make @ minimum 2% by wt. of cement used) modified plain/reinforced cement concrete for structural members having minimum characteristic compressive strength) -75mm thick in Grade M 25 with cement content not less than 330 kg per cum
- i. Construction of dry lean cement concrete sub base over a prepared sub-grade with coarse and fine aggregate conforming to IS:383
- j. Providing and laying design mix cement concrete of M-30 grade, in roads/ taxi tracks/ runways, using cement content as per design mix- Cement concrete prepared with batch mixing machine.

1.4. Detailed Scope of Work:

1.4.1.Road Works:

1.4.1.1. Pre-Construction Stage

- (i) The contractor shall coordinate and arrange for a kick-off meeting with all the pertinent stakeholders. (Traffic Police, Police, Hospitals, FSCL, BSNL, ADANI, HUDA, MCF, NHAI, DMRC, DHBVN etc)

- (ii) Bidder/contractor shall submit Dismantling and Construction plan and Construction Methodology to Faridabad Smart City Limited (FSCL) and have it approved prior commencing the works.
- (iii) The contractor shall review its appropriateness and accuracy with the drawings and specifications submitted. Should there be a need for further studies, the contractor shall conduct survey investigations, studies etc. at his own cost.
- (iv) Prior to commencing the demolition and construction works, the contractor shall assess the appropriate locations of all the underground utilities by using the state of the art technologies. In case there are discrepancies between the alignments of utilities shown on the drawing and those that exist on the ground, the contractor shall immediately inform the client in writing to resolve the matter.
- (v) Dismantling of existing infrastructure, which includes but not limited to structures, signboards, gantry, traffic signals post, removal of encroachments, Kerbstones, fencing, existing roads, street furniture, Hume pipes, overhead cables/wires and poles, Street lighting poles, Transformer foundation etc.
- (vi) At no point of time, the contractor shall disturb the on-going traffic, access to the properties, adjustment of RoW and shops existing along the road.
- (vii) Prepare a **traffic management plan** and have it approved by FSCL. The traffic management plan should clearly indicate how the traffic will be managed during the construction and have it approved by the FSCL and Traffic Police.
- (viii) The contractor shall submit the safety and quality assurance, Control plan to FSCL, and have it approved.
- (ix) Undertake the works by complying NGT norms and follows all safety standards including providing noise barriers if required.
- (x) The trees will be shifted/ transplanted in accordance and consultations with the FSCL and forest officials or relevant authorities.

1.4.1.2. Construction Phase

- a. Review the existing drawings submitted by FSCL and indicate any discrepancy found on the site different from the one indicated in the design;
- b. Follow all aspects of labour regulations, health and safety during the contract;
- c. Relocation of utilities shall be done by relevant agencies like Adani, Airtel etc. However, the contractor needs to coordinate and have approvals from the relevant agencies prior commencing the works. Wherever, the bidder is required to relocate the utilities, the cost of relocation shall be borne by the FSCL. The relocation charges shall be approved by FSCL as per the prevailing HSR.
- d. Site clearing and grubbing within the Right of Way.
- e. Shifting or transplanting of trees as per the drawings included in the tender.
- f. Excavation for utilities, road works, footpaths cycle tracks, landscaping, street lighting etc.
- g. Filling with suitable material as approved by the E in C.
- h. Removal of existing pavement and stack or dispose the excavated road materials as indicated by the E in C.
- i. All dismantled materials shall be stacked or disposed by the bidder as directed by the E in C.
- j. The cost of reused material shall be estimated by the E in C and such amount shall be recovered from the bidder in case if it used or damaged by the bidder.
- k. Cleaning and removal of deposits, silts, blockages from existing RCC/pipe drain;

- l. Construction of underground water supply, sewerage and storm water system including all manholes, Manholes covers, connecting to the existing lines as indicated in the drawings and specifications submitted in the tender.
- m. Construction of ducts for laying of LT/HT, OFC cables including all manholes, Manholes covers, connecting to the existing lines as indicated in the drawings and specifications submitted in the tender.
- n. Construction of main carriage way, kerb, depressed kerb, medians, raised pedestrian crossings, intersection improvements, footpaths, landscape, cycle tracks and road works as per drawings and specifications submitted in the tender.
- o. Construction of crash barriers as per drawings
- p. Construction of retaining wall (if any) as per drawings
- q. Supply and Fixing of Railing / Guard Rails along the Median and Road sides.
- r. Providing thermoplast pavement marking, pavement marker(Cat Eyes), road furniture (signs, road studs, median marker, pedestrian crossings, cycle tracks, rumble strips, solar powered traffic blinkers, delineators, AFP sheeting);
- s. Provision of kerbs and road markings with thermoplastic material, Traffic signs (Informatory, Mandatory, Cautionary) with retro-reflecting sheeting, kilometre stones, delineators and other road furniture;
- t. Providing, fixing and erecting of M.S. Railing.
- u. Fabricating, Supply And Fixing (including the foundation, super structure) Overhead Direction/ Advance Information Signboards Of Required Size Made Out Of Retro Reflective Sheeting Of Cube Corner Micro Prismatic Grade Conforming To IRC-67: 2012 & Type Viii, Fixed On Both Side Of ACM (Aluminum Composite Material) at locations as per the drawings.
- v. Provision of Utility ducts/RCC pipes for Road Crossings.
- w. Foundation for transformers, Poles, Feeder Pillars, Service Feeder Pillars etc
- x. Supply and Laying of underground LT/HT cables in direct buried duct/crossing pipes etc.
- y. Supply, Installation, Testing and Commissioning of H Poles with all accessories, LT/HT cables, transformers, Feeder pillars, Service Feeder pillar, Termination of Cables with termination kit, Earthing etc.
- z. Supply & Install Grass, Palms, trees, shrubs, hedges.
- aa. Landscaping work including the stone flooring, cc paver block, tiling, grating, saucer drain, cladding, painting etc
- bb. Construction of Under Ground Tank.
- cc. Supply, laying and commissioning of Drip irrigation system.
- dd. The bidder/contractor shall work in co-ordination with Smart Features contractor (Smart Features works shall start parallel with this contract at appropriate time);

1.4.1.3. Post Construction Phase

- a. Clearing of site and handing over of the works;
- b. Submission of “As Built Drawings” and other related documents to FSCL
- c. Rectification of the defects in the completed works during the Defects Liability Period;

1.4.1.4. Maintenance:

The contractor shall maintain the Smart Roads for a period of 5 (five) years commencing from the date of the Issue of Completion Certificate. Payment to the bidder/contractor for the maintenance shall be done on quarterly basis.

During the Maintenance Period, the Faridabad Smart City Limited (FSCL) shall provide to the Contractor access to the site for Maintenance in accordance with this Agreement. The obligations of the Contractor hereunder shall include:

- a) Permitting safe, smooth and uninterrupted flow of traffic on the Smart Road;
- b) Undertaking routine maintenance including prompt repairs of potholes, cracks, joints, drains, embankments, structures, pavement markings, lighting, road signs and other traffic control devices;
- c) Undertaking repairs to structures;
- d) Informing FSCL of any unauthorized use of the Smart Roads;
- e) Informing FSCL of any encroachments on the Smart Roads;

In respect of any deficiency, the Contractor shall, at its own cost, undertake repair or rectification in accordance with Good Industry Practice.

The Contractor shall remove promptly from the Smart Road any waste materials (including hazardous materials and waste water), rubbish and other debris (including, without limitation, accident debris) and keep the Smart Road in a clean, tidy and orderly condition, and in conformity with the Applicable Laws, Applicable Permits and Good Industry Practice.

1.4.1.5. Maintenance Requirements

The Contractor shall ensure and procure that at all times during the Maintenance Period, the Project Road (Smart Road) conforms to the maintenance requirements (the "Maintenance Requirements").

1.4.1.6. Maintenance Programme

The Contractor shall prepare a monthly maintenance programme (the Maintenance Programme") in consultation with the E in C and submit the same to the E in C not later than 10 (ten) days prior to the commencement of the month in which the Maintenance is to be carried out. For this purpose, a joint monthly inspection by the Contractor and the E in C shall be undertaken. The Maintenance Programme shall contain the following:

- a. The condition of the road in the format prescribed by the E in C;
- b. The proposed maintenance works; and
- c. Deployment of resources for maintenance
- d. Frequency and turnaround time for addressing the issue.

1.4.1.7. Safety, vehicle breakdowns and accidents

The Contractor shall ensure safe conditions for the Users, and in the event of unsafe conditions, lane closures, diversions, vehicle breakdowns and accidents, it shall follow the relevant operating procedures for removal of obstruction and debris without delay. Such procedures shall conform to the provisions of this Agreement, Applicable Laws, Applicable Permits and Good Industry Practice.

The Contractor shall promptly remove any debris from the Project Road (Smart Road) to enable safe movement of traffic and shall report all accidents to the FSCL and police forthwith.

1.4.1.8. Reduction of payment for non-performance of Maintenance obligations

In the event that the Contractor fails to repair or rectify any Defect or deficiency set forth in the below Table within the period specified therein, it shall be deemed as failure of performance of Maintenance obligations by the Contractor and the FSCL shall be entitled to penalise as per the clause indicated in the General Conditions of the Contract in lump sum payment for maintenance, without prejudice to the rights of the FSCL under this Agreement, including Termination thereof.

If the nature and extent of any Defect justifies more time for its repair or rectification than the time specified in the below Table, the Contractor shall be entitled to additional time in conformity with Good Industry Practice. Such additional time shall be determined by the E in C and conveyed to the Contractor with reasons thereof.

1.4.1.9. FSCL's right to take remedial measures

In the event the Contractor does not maintain and/or repair the Project Road (Smart Road) or any part thereof in conformity with the Maintenance Requirements, the Maintenance Manual or the Maintenance Programme, as the case may be, and fails to commence remedial works within the time provided by the E in C as the case may be, the FSCL shall, without prejudice to its rights under this Agreement including Termination thereof, be entitled to undertake such remedial measures at the cost of the Contractor, and to recover its cost from the Contractor. In addition to recovery of the aforesaid cost, a sum equal to actual cost plus 15% (fifteen percent) of such cost shall be paid by the Contractor to the FSCL as Damages.

1.4.1.10. Restoration of loss or damage to Project Road (Smart Road)

Save and except as otherwise expressly provided in this Agreement, in the event that the Project Road (Smart Road) or any part thereof suffers any loss or damage during the Maintenance from any cause attributable to the Contractor, the Contractor shall, at its cost and expense, rectify and remedy such loss or damage forthwith so that the Project Road (Smart Road) conforms to the provisions of this Agreement.

1.4.1.11. Overriding powers of the FSCL

If in the reasonable opinion of the FSCL, the Contractor is in material breach of its obligations under this Agreement and, in particular, the Maintenance Requirements, and such breach is causing or likely to cause material hardship or danger to the Users and pedestrians, the FSCL may, without prejudice to any of its rights under this Agreement including Termination thereof, by notice require the Contractor to take reasonable measures immediately for rectifying or removing such hardship or danger, as the case may be.

In the event that the Contractor, upon notice under above Clause, fails to rectify or remove any hardship or danger within a reasonable period, the FSCL may exercise overriding powers under this Clause and take over the performance of any or all the obligations of the Contractor to the extent deemed necessary by it for rectifying or removing such hardship or danger; provided that the exercise of such overriding powers by the FSCL shall be of no greater scope and of no longer duration than is reasonably required hereunder; provided further that any costs and expenses incurred by the FSCL in discharge of its obligations hereunder shall be recovered by the FSCL from the Contractor, and the FSCL shall be entitled to deduct any such costs and expenses incurred from the payments due to the Contractor for the performance of its Maintenance obligations as per the Penalty clause indicated in the GCC.

1.4.1.12. Repair/rectification of Defects and deficiencies

The Contractor shall repair and rectify the Defects and deficiencies specified within the time limit set forth in the table below.

Nature of Defect or deficiency		Time limit for repair/rectification
ROADS		
(a)	Carriageway and paved shoulders	
(i)	Pot holes	24 hours
(ii)	Any cracks in road surface	15 (fifteen) days
(iii)	Any depressions, rutting exceeding 10 mm in road surface	30 (thirty) days
(iv)	Bleeding/skidding	7 (seven) days
(v)	Any other defect/distress on the road	15 (fifteen) days
(vi)	Damage to pavement edges	15 (fifteen) days
(vii)	Removal of debris, dead animals	6 hours
(b)	Drains and culverts	
(i)	Damage to or silting of culverts and side drains	7 (seven) days
li	Desilting of drains in urban/semi urban areas	24 hours
lii	Railing, parapets, crash barriers	7 (seven) days (Restore immediately if causing safety hazard)
(c)	Road side furniture including road sign and pavement marking	
I	Damage to shape or position, poor visibility or loss of retro-reflectivity	48 hours
li	Painting of km stone, railing, parapets, crash barriers	As and when required/Once every year
lii	Damaged/missing road signs requiring replacement	7 (seven) days
Iv	Damage to road mark ups	7 (seven) days
(d)	Road lighting	
I	Any major failure of the system	24 hours
li	Faults and minor failures	8 hours
(e)	Trees and plantation	
I	Obstruction in a minimum head- room of 5 m above carriageway or obstruction in visibility of road signs	24 hours
ii	Removal of fallen trees from carriageway	4 hours
iii	Deterioration in health of trees and bushes	Timely watering and treatment
iv	Trees and bushes requiring replacement	30 (thirty) days
v	Removal of vegetation affecting sight line and road structures	15 days
	Foundation	
I	Scouring and/or cavitation	15 days
(f)	Other items	
(i)	Damage or deterioration in kerbs, parapets, handrails and crash barriers	3 (three) days or (immediately within 24 hours if posing danger to safety)
(i)	Damage to wearing coat	15 (fifteen) days
(ii)	Growth of vegetation affecting the structure or obstructing the storm water.	15 (fifteen) days

2.1. SCOPE OF WORK FOR UTILITY

2.2. General:

The alignment of the existing utilities indicated in the RFP dwg are indicative only. The contractor needs to inform the FSCL when the alignment shown in the drawings are different from the existing situation.

The contractor needs to work with utmost care and ensure that the existing utilities are not damaged and the operations (services) are not hindered at any point of time.

If there are any damages to the existing utilities on account of the work undertaken by the contractor, the damages shall be attended immediately & rectified within 24 hours at his own cost. In case the damages are not attended to the satisfactory of the E in C, the same will be undertaken by the E in C as amount will be deducted from the contractors' bill as indicated in the Conditions of Contract".

On the both sides there will be footpath. A cycle track is also proposed as shown in sectional drawing. Also it is proposed to construct a new storm water drain on roads

As well it is proposed to construct electrical utility duct on both the sides of the road, shift/remove the transformers, electricity poles, and there is crossing of electrical utilities across road and at the junctions, the details can be found in electrical section.

OFC service provider network, Gas pipe line will be shifted by concerned service provider in coordination with authorities and contractor.

It is planned to have a new sewer and water supply line in anticipation of new demand.

The connection of existing storm water drain, water supply and sewerage system shall be done with due care.

The Contract also includes maintenance of the Works for a period of Five Years after the issue of the Completion Certificate for the whole of the Works. Contractor's staff shall be stationed at Site throughout the Maintenance Period for attending to any defects that may be noticed.

The rates quoted by the contractor for different items of BoQ shall include the cost of all temporary arrangements with men, materials, tools and tackles for diversion of flow so that the services of existing network of utilities such as sewerage, storm water line, water pipe lines, etc should not be stopped during the construction period. Contractor shall also obtain the permission from competent authority prior to execution of these work." The contractor shall not claim separate payment for such works. Apart from the above if, any thing which is specifically not mentioned but is required for proper execution of work shall be in contractor's scope.

2.3. DETAILED SCOPE OF WORK:

The works shall include but not be limited to:

- (a) Validation of Existing Utilities Services and submit the Utility map to FSCL
- (b) Providing relocation plan for shifting of existing utility services, if required. Submitting the same to FSCL for approval.
- (c) Checking and validating tender drawings before execution of work, if any discrepancy to be informed to FSCL immediately.

- (d) In consultation with FSCL, Provide detail drawing for connection between existing utility services and proposed utilities.
- (e) Preparing shop drawings for proposed utilities services as per RFP drawings and as per site conditions/invert levels. And validation of existing utility services submitting the same for approval purpose.
- (f) Laying of proposed utilities and relocation of existing services as per the construction drawings issued by FSCL.
- (g) Providing detail sequence of execution of work such that there is minimum inconvenience to consumers and without disturbing of live utilities, and provision for diversions of existing of utilities wherever required.
- (h) Providing intimation to consumers and utility service provider before execution of work. Proposed plan to be submitted to FSCL prior to executing the same.
- (i) An existing RCC storm water drain cum sewerage line is passing through the same road as per below detail. This storm cum sewerage drain shall be dismantled after the new storm water drain is constructed with all appropriate connections in place.
- (j) Construction of RCC storm water drain including manholes and catch basins/ collection chambers.
- (k) Contractor shall submit the as built drawings and have it approved by FSCL.
- (l) Connection of water supply to be taken with prior approval of FSCL from the nearest water supply mains of sectors.
- (m) Connecting the proposed sewer line to the existing nearest sewer manholes. Prior approval to be taken from FSCL before execution of work.
- (n) Contractor has to co-ordinate with other agency such as gas agency (Adani) and OFC agency such as Vodafone, Idea & Reliance in order to process with further with co-ordination work.
- (o) All telecom agencies and others (OFC) have to accommodate their cables in the proposed OFC duct of 300mm dia. RCC NP2 hume pipe.
- (p) Contractor has to take approval of respective services from concerned authority also.
- (q) Manhole coming in carriageway need to be properly jacketed.
- (r) Contractor has to take precaution so that utility service is not damaged during excavation
- (s) Contractor has to take permission and inform all Concerned agency(GAS Agency & OFC agency) & governmental authority before start of work
- (t) Contractor need to Mark pipe identification on Road in order to recognize type of Utility.

2.3.1.STORM WATER DRAIN

It is proposed to have storm water drain on road alignment as per tender drawings.

storm water drain channel shall have manholes with SFRC heavy-duty rated covers.

Catch basin to be constructed to carry all the surface water from road, footpath and transfer it by RCC Hume pipe to the near main storm water drain. Catch basin shall have RCC heavy-duty perforated covers and catch basin along the edge of road shall have vertical opening for carrying surface water.

All the manhole and catch basin top of covers to have minimum following details - STORM WATER, FSCL/MCF, and Year of manufacturing.

Damaged manhole cover , repair of Storm water Manhole need to be done in order to avoid water logging.

Sewer Connection to be removed from existing Storm water Drain channel & to be connected to Sewer Line only.

New Catch basin need to be provided to Storm water Drain Channel.

The contractor shall conduct all required surveys to find out the level/ invert level required for services and all investigations required to perform the job

Alignment of storm water drain and location of catch basin provided in tender drawing is tentative. Contractor has to verify the alignment along with the existing utilities services and Invert levels of the proposed drain to be matching with the invert level of existing storm water box drain. Contractor has to prepare shop drawings for proposed utilities services as per RFP drawings and as per site conditions/invert levels and validation of existing utility services submitting the same for approval purpose. Storm water proposal has been shown in below table as per requirement as well as per Sectional dwg & Plan Dwg.

The storm water discharge of Talab road and Sector 19 internal road is disposed in the Ambedkar marg storm water drain channel and the invert level are to be maintain as per the site. The Ambedkar Marg storm drains are proposed to be connected to the storm drain proposed on By Pass Road. However for further details kindly refer the tender drawings.

Contractor to Submit shop drawings for proposed utilities services as per RFP drawings and as per site conditions/invert levels before execution of work and have approval from FSCL. Contractor has to submit shop dwg till satisfaction of FSCL.

A. Phase – I, Roads

SR NO	ROAD DESCRIPTION	PROPOSED	DESILTING REQUIRED OR NOT
1	AMBEDKAR MARG		
	From NH to Bypass		
	LHS	Same size of existing storm drain to be reconstructed.	
	RHS	1600mm wide x 2200mm depth (Proposed)	Nil
2	BYPASS ROAD		
	From faridabad to Delhi		
	RHS	3000mm wide x 2.900mm depth (Proposed)	
3	INTERNAL ROAD SECTOR 19		
	LHS	1000mm x 1500mm & 600 x 600mm (Proposed)	Not Applicable
	RHS	600mm x 1000mm , 800mm x 1000mm & 600 x 600mm	Not Applicable
4	BADKHAL ROAD		
	From Ankheer Chowk to Badkhal chowk		
	LHS	600mm RCC NP3 Hume pipe	Not Applicable
	RHS	2000mm x 1500mm (Proposed) & 600mm RCC NP3 Hume pipe.	Not Applicable
	From Badkhal Mor to Ankheer Chowk		
	LHS	600mm RCC NP3 Hume pipe.	
	RHS	600mm RCC NP3 Hume pipe.	

SR NO	ROAD DESCRIPTION	PROPOSED	DESILTING REQUIRED OR NOT
5	TALAB ROAD		
	LHS	900mm RCC NP3 Hume pipe.	
	RHS	900mm RCC NP3 Hume pipe.	
6	LINK ROAD		
	LHS	600mm RCC NP3 Hume pipe.	
	RHS	600mm RCC NP3 Hume pipe.	

B. Phase – II, Roads

S No	ROAD DESCRIPTION	PROPOSED	EXISTING STATUS
1	MAIN BANDH ROAD		
	From Badkhal Chowk to Patel Chowk		
	LHS	450mm x 450mm (Proposed channel)	To be abandoned if present at some stretches.
	RHS	450mm x 450mm (Proposed channel)	To be abandoned if present at some stretches.
2	ITI ROAD		
	From Patel Chowk to Bhagat Singh Chowk		
	RHS	1000mm x 1000mm (Proposed Channel)	Not Applicable
3	RAILWAY ROAD		
	From Bhagat Singh Chowk to Pravesh Marg		
	LHS	600mm x 800mm (Proposed channel)	Not Applicable
4	SECTOR-21 ROADS		
	Internal Road-1		
	LHS	1000mm x 1000mm (Proposed Channel)	Dismantle if found within excavated stretch.
	Internal Road-2		
	LHS	1200mm x 1400mm (Proposed Channel)	Dismantle if found within excavated stretch.
	Sector-21D Dividing Road		
	LHS	1000mm x 1000mm (Proposed Channel) 1200mm x 1500mm (Proposed Channel)	Dismantling of 300mm RCC pipe.
	RHS	400mm x 600mm (Proposed Channel) 1000mm x 1300mm (Proposed Channel)	Dismantling of 300mm RCC pipe.
	Sector-21B Dividing Road		
LHS	1500mm x 1500mm (Proposed Channel) 1500mm x 1900mm (Proposed Channel)	Dismantling of approx. 1500mm wide drain channel	

S No	ROAD DESCRIPTION	PROPOSED	EXISTING STATUS
		600mm x 600mm (Proposed Channel)	
	RHS	1500mm x 2000mm (Proposed Channel)	Not Applicable
	Jiva Marg		
	LHS	800mm x 1000mm (Proposed Channel) 1000mm x 1000mm (Proposed Channel)	Dismantle if found within excavated stretch.
5	SHAHEED BHAGAT SINGH MARG		
	From Bhagat Singh Chowk to Neelam Chowk		
	LHS	1500mm x 1500mm (Proposed Channel)	Dismantling of approx. 2500mm wide drain channel
	RHS	1500mm x 1200mm (Proposed Channel)	Not Applicable
6	STATION ROAD		
	From NH to Railway station		
	LHS	1000mm x 800mm (Proposed Channel)	Not Applicable
	RHS	600mm x 600mm (Proposed Channel) 600mm x 800mm (Proposed Channel)	Not Applicable
7	BARAHI TALAB ROAD		
	LHS	400mm x 400mm (Proposed Channel)	Not Applicable
8	FINAL DISPOSAL AT SECTOR-21A		
	From left of Railway track in north direction	2400mm x 2400mm (Proposed Channel)	Dismantling of drain channel (dimensions not known)

2.3.2.SEWER SYSTEM

Here utmost care has to be taken that sewer pipe need not be damaged by contractor.

Contractor has to reconstruct the existing manholes that shall be on the carriageway of proposed road. Level. Wherever required manhole covers to be replaced and contractor has to submit the location and quantity of such manholes to FSCL for approval before proceeding of construction activity.

Top of manhole covers and inspection chambers to have minimum following details - SEWER, FSCL/MCF, Year of manufacturing.

Contractor has to prepare shop drawings for proposed utilities services as per RFP drawings and as per site conditions/levels. Also validation of existing utility services needs to be done submitting the same for approval purpose till satisfaction of FSCL.

Sewer pipe shall be laid as per table given below and as per proposed section & plan drawing. The proper sand bedding should be provided during the laying of the pipelines.

A. Phase – I, Roads

SR NO	ROAD DESCRIPTION	SEWER SIZE
PROPOSED		
AMBEDKAR MARG		
1	From NH to Bye-pass	
	LHS	600mm dia RCC NP3 hume pipe to be placed .
	RHS	Existing manholes present on the carriageway shall be raised to the proposed road level & the existing manhole covers to be replaced with new.
BYPASS ROAD		
2	From Faridabad to Delhi	Not Required
INTERNAL ROAD SECTOR 19		
3	From Ambedkar to Badkhal Road	Only manhole to be Raised upto proposed road level along with replacement of manhole cover.
BADKHAL ROAD		
4	From Ankheer chowk to Badkhal chowk	Only manhole to be Raised upto proposed road level along with replacement of manhole cover.
	From Badkhal Mor to Ankheer chowk	Only manhole to be Raised upto proposed road level along with replacement of manhole cover.
5	Talab Road	Only manhole to be Raised upto proposed road level along with replacement of manhole cover.
6	Link Road	Only manhole to be Raised upto proposed road level along with replacement of manhole cover.

B. Phase – II, Roads

S No.	ROAD DESCRIPTION	EXISTING STATUS	PROPOSED
MAIN BANDH ROAD			
1	From Badkhal Chowk to Patel Chowk		
	LHS	NA	RCC 250mm dia. having 860m of length
ITI ROAD			
2	From Patel Chowk to Bhagat Singh Chowk		
	LHS	Pipe is silted as per visual analysis	
RAILWAY ROAD			
3	From Bhagat Singh Chowk to Pravesh Marg		
	LHS	Pipe is silted as per visual analysis	
SECTOR-21 ROAD			
4	Internal Road-1		
	LHS	Pipe is silted as per visual analysis	
	RHS	Pipe is silted as per visual analysis	
	Internal Road-2		
	LHS	Pipe is silted as per visual analysis	
	Sector-21D Dividing Road		
	LHS	Pipe is silted as per visual analysis	
	RHS	Pipe is silted as per visual analysis	
	Sector-21B Dividing Road		

S No.	ROAD DESCRIPTION	EXISTING STATUS	PROPOSED
	LHS	Pipe is silted as per visual analysis	
	Jiva Marg		
	LHS	Pipe is silted as per visual analysis	
5	BHAGAT SINGH MARG		
	From Bhagat Singh Chowk to Neelam Chowk		
	RHS	Pipe is silted as per visual analysis	
6	STATION ROAD		
	Back side of Sant Nagar		
	RHS	NA	RCC 250mm dia. having 610m of length

2.3.3.Desilting & Rehabilitation of existing Sewer

- a. Corridor survey to determine sewer alignment including locating MH/Chamber, tracing uncovering of buried manholes, proximity of structure, measurement of exact length centre to centre MH/Chamber, taking Ground Levels, Invert
- b. Flow diversion of sewer shall be taken care for isolation of stretch.

2.4. The Contractor shall strictly follow the safety guideline as mentioned below for safe man entry and working in sewer lines.

2.5. GUIDELINES FOR SAFE ENTRY AND WORKING IN SEWERS

2.5.1.SAFE WORK PRACTICE PRINCIPLES

2.5.1.1. Introduction

These general guidelines are intended to assist the Contractor in the development of safe work practices. Where the risk assessment indicates that a particular hazard cannot be present, the precautions to control that hazard do not apply. Remember that a favourable history does not guarantee absence of hazard on this occasion.

2.5.1.2. Confined Space

“Confined space”, in relation to a place of work, means a space of any volume which a person may at any time enter or be allowed to be enter in which the atmosphere is laible at any time to be oxygen deficient. This includes but not limited to pipes, sewers, manholes, tunnels, shafts, ducts, other similar sewerage installations and etc.

The Contractor shall develop acceptable work practices and safe entry procedures based on the guidelines provided hereunder and the other guidelines including DJB/Metro on safety precautions to be observed during sewer desilting/ lining work included in this specification and implemented on site

2.5.1.3. Notification to Work in Confined Space

The Contractor shall obtain an entry permit from the Engineer for each occupancy of any confined space. The Contractor shall furnish all required details in an approved format to the Engineer for permission to work in confined space at least 24 hours prior to the entry. Where prolonged work is involved, the permit

must be renewed for each shift. An incident which substantially alters the condition of a confined space entry requires immediate evacuation and reassessment of the condition.

2.5.1.4. Air Quality and Ventilation

Contaminant control and effective ventilation are major factors influencing air quality in a confined space. The ventilation must be adequate to clear pre-existing contaminated air and maintain a respirable atmosphere during planned work. This ventilation may be permanently installed or portable equipment used for this task. For general ventilation, fresh air should be supplied to the workplace. Within the sewer system this creates an environment which displaces contaminated air in the immediate vicinity.

Where a task generates atmospheric contaminants in a specific area e.g. use of chemical such as polyester resin, adequate local exhaust ventilation should be used to remove the contaminants. Where failure of the mechanical ventilation system would result in deterioration of air quality, the controls must be clearly tagged to prevent accidental interference and the ventilation system monitored while the confined space is occupied. Self Rescuers must be carried whenever failure of the ventilation system or changes in the working environment can create a contaminated atmosphere. The self rescuer can be a self contained breathing apparatus, oxygen self rescuer, or short duration self contained breathing apparatus, depending on the time taken to reach open air.

Note: Obtain occupational hygiene advice on the- selection or performance of ventilation system where this is not specified in the work practice or plant design.

2.5.1.5. Lighting

Any regularly accessed confined space should be illuminated with electrical installation to appropriate Indian Standard or equivalent. Portable lighting may be used to supplement permanent lighting in the workplace. Temporary mains powered lighting installed for a task must comply with the requirements of appropriate Indian Standard. Miners lamps, mounted on a safety helmet may be used as an alternative to a hand held torch for personal illumination.

The possibility of a flammable atmosphere must be eliminated by isolation, cleaning, ventilation purging etc.

Where the confined space has been proclaimed as a flammable gas hazard area, all fixed and temporary electrical installation must comply with appropriate Indian standard. Torches and portable lights must comply with appropriate Indian standard.

- a. Illumination standards are:-
- b. General Lighting:- 40 lux minimum, equivalent to a poorly lit room
- c. Stairway lighting:- 80 lux minimum
- d. Task Lighting:- 240 lux minimum (normal workshop requirements)

2.5.1.6. Equipment usage, Standards and Maintenance

All confined space safety equipment must meet established standards and be of appropriate design for the proposed usage. The equipment must be checked for visible damage and correct operation before each use. Preventative maintenance must be performed by trained, and where necessary, authorised persons at the intervals recommended by the equipment manufacturers. The Contractor shall submit to the Engineer evidence of such periodic check and maintenance of the equipment used for confined space entry at every month during the first week of the month.

2.5.1.7. Room to work

When the constricted volume of a worksite prevents normal work postures and tool movement, the need for special tools or frequent work rotation should be considered.

2.5.1.8. Control of Flooding

When a confined space is normally liquid filled, accidental return to service must be prevented by double isolation e.g. insertion of suitable blanking piece, plugging with inflatable plugs, temporary coffer dams as a second isolation in a manhole or other effective means.

2.5.1.9. Flow Control

Where a sewer is entered while flowing, rapid increase in flow must be prevented by use of stop logs. Isolation of pumping stations, weather watch and other means appropriate to the sewer catchment. Adequate communication with the person responsible for flow diversion must be maintained for the duration of the entry.

2.5.1.10. Drowning

Where deep or flowing water is present, use personal flotation devices. Safety harness and lifeline, safety nets. etc. as appropriate to prevent drowning.

2.5.1.11. Fire and Explosion

Adequate precautions must be taken to minimise the risk of fire or explosion when entering a confined space for any purpose.

2.5.1.12. Presence of Flammable Gas

The presence of flammable gas, flammable dust or the possibility of the presence of airborne substances in flammable quantities may create a hazardous Area. Care shall be taken by the authorised person to determine the presence of any such flammable situation in the confined space before entry. Smoking or lighting any cigarette or box matches in confined space shall be strictly prohibited. The flammable gases of concern are methane, digester gas, vapours from flammable liquid, and vapours and gases from trade waste discharges.

2.5.1.13. Manual Handling of Tools etc.

Safe system of work should be followed to protect against falls of persons or objects and crush by moving or falling objects. Extra care is needed if normal manual handling gear is not available or confined space safety gear (Harness, Respirator) is worn.

2.5.1.14. Noise

Reverberation within a confined space can increase noise levels, especially if more than one person is working. Heavy duty hearing protection may be required.

2.5.1.15. Vermin

All persons working in confined spaces should be aware of the health hazards presented by the presence of vermin. The presence of cockroaches etc does NOT indicate that the atmosphere is free of danger to health.

2.5.1.16. Standby and Communication

A member of the confined space work team is allocated the task of maintaining communication with the members inside the confined spaces. This task may be rotated among the members of the team. The Standby person must be trained and be physically capable of providing the assistance and life support in an emergency and must have sufficient proficiency in Marathi, Hindi and English languages to promptly communicate information by radio or telephone when required.

While acting as stand-by, this person must not enter the confined space or leave the vicinity unless relieved from this duty. A standby person is needed for all confined space entries. The Safe System of Work must indicate the process for communication from the confined space to the standby, e.g. 2 way radios. 'Man down' alarm, line of sight etc.

2.5.1.17. Fitness Assessment

An assessment of fitness, including cardiovascular and respiratory health, is required to ensure that all persons entering confined spaces, or acting as the stand-by person, can comply with the physical demands of the job, without risk to their health.

The contractor shall ensure conducting the medical tests i.e. chest X-Ray, TLC/DLC/Urine and Sputum at regular intervals for the sewer workers engaged on the rehabilitation works and submit its records to DJB.

2.5.1.18. Emergency Rescue and First Aid

No person shall enter any confined space, even in an emergency, without first ensuring all safety requirements have been met. A safety emergency plan may assist in a safe, speedy response in the event of an emergency.

All confined space work teams must be trained and equipped to sustain life and be able to summon emergency help. Provide first aid and assist emergency service personnel, if requested.

Rescue of persons apparently overcome by toxic gases in a sewer or other confined space must only be attempted by trained persons using supplied air breathing apparatus. Stabilisation of other injuries must be prioritised against the availability of breathable air.

2.5.1.19. Gas Detector

The Contractor shall engage an authorised person for gas monitoring and detection. This person shall be trained to operate and response test gas testing equipment and is authorised by management to perform the necessary tests to decide whether a category 2 or 3 confined space is fit to enter.

Gas testing can only be performed by persons trained in gas testing, using equipment appropriate for the anticipated contaminants. This person can perform other duties provided these do not conflict with the gas testing task.

2.5.1.20. Specialist Gas Detector

This person has technical qualifications and acceptable training to operate and response test gas testing equipment, including hydrocarbon detectors and detector tubes and assesses portable ventilation systems. He is authorised by management to carry out atmospheric testing to establish entry conditions for all confined space categories, and to establish whether a Category 1 confined space can be re-classified to a Category 2. He also performs tests to verify whether hot work is permitted in gas hazard areas.

2.5.1.21. Cleaning

Where possible, cleaning should be performed without entry to the confined space, even if only preliminary cleaning is possible.

Particular attention should be given to the probability of releasing hydrogen sulphide when disturbing microbiologically active sludge and sediments which have accumulated in a confined space. Supplied air respiratory protection shall be worn where such residues exist and effective ventilation cannot be guaranteed. Continuous gas monitoring is required even when supplied air respirator protection is used.

Hose couplings should be designed to resist accidental dislodging or loosening. Both the operators and the standby person should be able to stop the flow of cleaning material into the confined space.

Hydro jetting must be performed according to the relevant regulations. Where chemical compound is used in within the confined space, the chemical compound should be classed in the Material Safety Data Sheets as non-irritant to respiratory system, eyes and skin. If this is not possible then appropriate respirator skin and eye protection must be worn. Substance specific air monitoring may be required.

2.5.1.22. Visitors

A visitor to a confined space is a person other than a contractor, who is not a member of the Confined Space Work team. Visitors must be escorted and trained or inducted in the necessary skills for that entry and shall sign an indemnity form before entry into a confined space.

2.5.1.23. Hazard Control

Hazards to be identified and controlled include but are not limited to: access. Mechanical and electrical isolation, flow isolation and control, drowning and engulfment, last known contents, atmospheric contaminants, temperature extremes, security and public access.

2.5.1.24. Air Quality Standard For Entry

The acceptable limits of some gases in confined spaces are:

	1 Gas/Vapour Present	2 Acceptable Limits
a	Oxygen Content (O)	19.5% to 23.5% by volume.
b	Flammable Gas/Vapour :	5% of Lower Explosive Level (LEL)
c	Hydrogen Sulphide (H ₂ S)	10 Parts Per Million (ppm) Maximum
d	Carbon Monoxide (CO)	30 Parts Per Million (ppm) Maximum,

2.5.1.25. Carbon Monoxide (CO)

Carbon monoxide is colourless. Odourless, flammable and toxic. Its common sources are fire, motor vehicle exhausts and cigarette smoke.

This gas is a chemical asphyxiant and is readily absorbed by the haemoglobin in the blood. Then haemoglobin is unable to transport oxygen to the body tissues and the body becomes oxygen starved. These effects are more pronounced with hard work or for heavy smokers. Symptoms include headache (50-200ppm), nausea (400ppm), and irregular heartbeat (1200ppm). Collapse and death (2000ppm).

The entry permit limit is 30 Parts Per Million (ppm). Maximum with an IDLH value of 1500 ppm. (IDLH –Immediately Dangerous to Life and Health)

Note: Some gas detecting machine sensors are cross sensitive, H₂S being detected by the CO cell and vice versa. Alarm by either sensor requires evacuation and re-evaluation of the safe system of work.

2.5.1.26. Flammable Gas/Vapour

A gas or vapour which will burn when mixed with air in certain proportions and ignited.

The mixture which contains the least amount of flammable gases which will explode is called the Lower Explosive Limit (LEL) The mixture, which contains just enough Oxygen to let the flammable gas explode is called the Upper Explosive Limit (UEL). The flammable range varies for gases and vapours

Many of these have toxic effects when inhaled and a Workplace Exposure Standard has been issued to protect workers from this Gas/Vapour. The Contractor shall obtain relevant Workplace Exposure Standard (WES) for use in the site.

Gas/Vapour	Flammable range in %	5% LEL	WES
Butane	1.9- 8.5	950ppm	800ppm
n-Hexane	1.2 -6.9	600ppm	50ppm
Methane	5-15	2500ppm	Asphyxiant
Petrol	1.3 - 6	650ppm	900mg/cum
Trichloroethylene	12.5 - 90	6259ppm	50ppm

2.5.1.27. Hydrogen Sulphide (H₂S)

Hydrogen sulphide is a colourless, toxic and flammable gas which usually has the odour of rotten eggs. in sewerage systems it is usually derived from the action of bacteria on the sulphur compounds in anaerobic or old sewage. A small amount of sludge or slime in wet wells or sewers will release a lot of H₂S when disturbed.

After a few minutes exposure, the ability to smell hydrogen sulphide by a person is lost and then hydrogen sulphide becomes more dangerous as its presence is no longer obvious and the person could become an innocent victim.

It can sometimes be detected by odour at less than. 0.1 ppm but can be readily detected by odour at 4ppm. More serious health effects include eye irritation (10ppm), respiratory irritation (50 ppm), headache, nausea, dizziness (200ppm). Collapse and death (700ppm).

The entry permit limit is 10 Parts Per Million (ppm), Maximum with an IDLH value of 300ppm.

Note: Some gas detecting machine sensors are cross sensitive, H₂S being detected by the CO cell and vice versa. Alarm by either sensor requires evacuation and re-evaluation of the safe system of work.

2.5.1.28. Methane (CH₄)

The most common flammable gas found in sewers is methane. This mainly comes from gas pipe leaks in the city's gas distribution systems. It can also be derived from the action of anaerobic bacteria on rotting material. However a range of other flammable gases and vapours may be encountered. These include LPG, petrol vapour and other solvents.

Digester gas, found in anaerobic sludge digesters on sewage treatment plants. is a flammable mixture of methane nitrogen and carbon dioxide.

Methane is a colourless, odourless gas. Although pure methane is slightly lighter than air, the relative density of methane/ air mixtures is similar to air in the entry permit range. Methane is hazardous because of its flammability, i.e. between concentrations of 5% to 15% in air, may explode if an ignition source is present.

High concentrations of methane may result in oxygen deficiency. Injury or death results from lack of oxygen not methane toxicity classifying methane as a simple asphyxiant.

Note: that the entry permits level is 5% of LEL, NOT 5% flammable gas.

2.5.1.29. Oxygen Content (O₂)

Fresh air contains 20.9% oxygen.

In a confined space, oxygen can be used up by bacteria in sewage or sludge, rusting of iron fittings. Burning (or welding) or displaced (pushed out) by other gases.

Breathing of air which contains reduced oxygen results in increasingly serious health effects. These range from impaired coordination and faulty judgement (12-16% O₂) to collapse and rapid death (less 6% O₂)

Increased oxygen readings can only come from instrument error or by leakage from oxygen cylinders, liquid oxygen tank, etc. High oxygen levels greatly increase fire hazards, fires burn fiercely; oily clothing and hair can catch fire without an ignition source.

The entry permit levels are 19.5% to 23.5.% by volume.

2.5.1.30. Definition

- a. Parts per million (ppm)
- b. Parts of gas or vapour per million parts of contaminated air by volume at 20°C and 1 bar pressure.
- c. 1 ppm = 0.000 1%
- d. Percentage
- e. Parts of substance per 100 parts of air, water etc.
- f. 1 % = 10,000 P

2.5.1.31. Other Atmospheric Contaminants

Entry, unless wearing air supplied breathing apparatus, is not permitted unless atmosphere contaminants are below the relevant 8 hour time weighted average (TWA) Workplace Exposure Standard. This limit applies for all entries including brief exposures. Entry wearing breathing apparatus is only permitted where the concentration of the contaminant is within the protection factor of the breathing apparatus and below the IDLH (Immediately Dangerous to Life & Health) value.

2.5.1.32. Sewer Gases

Air in contact with live sewage contains gases released from the sewer. For safe entry, contaminated air must be replaced with clean air by ventilation of the confined space. The resulting atmosphere must be confirmed by gas testing.

Discharge of untreated wastes, e.g. hypo chlorites, electroplating effluent, acids may result in generation of chlorine, hydrogen cyanide and other harmful gases some distance from the original discharge.

2.5.1.33. Confined Space Categorisation

The confined space category is a guide to developing a safe system of work. The confined space category may change to a more stringent level as a result of adverse environmental factors or work produced contaminants. Alternatively it may change to a less restrictive category if appropriate engineering upgrades, whether temporary or permanent, are implemented.

2.5.1.34. Category 1 - Confined Space

Entry allowed only if flammable gas is below 5% of L.E.L. and other gases are within the protection factor of the respiratory protective equipment used.

Visibility must be adequate

Personal Safety

- a. wear specified protective clothing for the hazards
- b. wear safety harness
- c. use lifeline where appropriate

Respiratory Protection

- (i) test air quality prior to entry. by a Specialist Gas Detector
- (ii) ventilate to reduce contamination
- (iii) monitor air quality as directed by the Specialist Gas Detector

wear airline breathing apparatus with backup air supply OR wear self contained breathing apparatus

Note: Oxygen self rescuer is not a backup for an airline used in contaminated atmospheres.

If the Category 1 confined space is a chemical storage tank, it can be reclassified to a Category 2 or 3 confined space when the Specialist Gas Detector confirms that the chemical has been cleared from the interior.

Sewer, wet wells etc can be reclassified by a Specialist Gas Detector to a lesser confined space only when an approved safe system of work is employed. This safe system of work must provide for demonstrated control of airborne contaminants and other hazards in the workplace, to provide conditions equivalent to a category 2

Hot work requires control of fire and explosion hazards and may require air supplied breathing apparatus to control fumes irrespective of the confined space category. A Hot work permit is required in addition to the normal entry permit.

2.5.1.35. Category 2 - Confined Space

Entry allowed only if all gases are within entry permit limits

Personal Safety

- a. wear specified protective clothing for the hazards
- b. wear safety harness
- c. use lifeline where appropriate

Respiratory Protection

- (i) test air quality prior to entry
- (ii) If air quality test fails refuse entry until reason found and rectified, or revert to Category 1 entry conditions.
- (iii) ensure adequate ventilation
- (iv) monitor air quality during entry
- (v) carry oxygen self-rescuer

Note: Standby person must have SCBA (Self-contained Breathing Apparatus) readily available.

Hot work requires control of fire and explosion. Hazards and may require air supplied breathing apparatus to control fumes irrespective of the confined space category. A Hot work permit is required in addition to the normal entry permit. A hydrocarbon check by a 'specialist gas detector' is required unless the environment can be upgraded to Category 3 conditions.

2.5.1.36. Category 3 - Confined Space

Entry permit required (unless using a posted entry procedure for routine operation of the facility) for each shift that the structure be occupied.

Personal Safety

- a. wear protective clothing specified for the hazards

Respiratory Protection

- a. test air quality prior to entry
- b. If the proposed work can generate airborne contaminants, arrange ventilation. Respiratory protection and/or air quality monitoring as appropriate.

Hot work requires hot work permit and control of fumes.

If air quality test fails, revert to Category 1 entry conditions or refuse entry until reasons found and rectified.

2.5.1.37. Category 4 - Confined Space

- a. Follow facility safety procedures.
- b. Personal Safety.
- c. wear protective clothing specified for the hazards
- d. Respiratory Protection**
- e. evacuate when alarms advise
- f. Hot work requires control of fumes.

Separate Permit(s) required for chemical cleaning and/ or Hot Work. If evacuation alarm sounds, evacuate following site emergency procedure. Reoccupy as a Category 2 confined space.

2.6. Generic Entry Summary

	Category 1	Category 2	Category 3	Category 4
Entry Permit	yes	yes	yes	Yes

	Category1	Category 2	Category 3	Category 4
Standby Person	yes	yes	yes*	*
Communication to remote standby			yes*	
Protective Clothing	yes*	yes*	yes*	yes*
Safety Harness	yes	yes		
Lifeline/Fall arrester	yes	yes		
SCBA	yes*	#		
Airline and backup	yes*			
OSR	yes*	yes*		
Specialist gas tester	yes			
Gas tester		yes	yes	Yes
Gas monitoring	yes	yes		
Ventilation	yes*	yes*	yes	Yes

*Appropriate choice given in Safe Work practice for the task

Required by Standby Person

2.6.1. WATER SUPPLY SYSTEM

Here utmost care to be taken by contractor that Water supply pipe need not be damaged.

Valve need to be proposed and provided for isolation purpose. The valve chambers to be constructed in brick work with heavy-duty cover.

Alignment of water supply line provided in tender drawing is tentative. Contractor has to verify the alignment along with the existing utilities services and identify the location of tapping from distribution mains of sectors.

Contractor shall be Submitted shop drawings for proposed utilities services as per RFP drawings and as per site conditions/invert levels before execution of work and have approval from FSCL. Contractor has to submit shop dwg till satisfaction of FSCL.

Providing, laying and jointing of water distribution pipes as per the drawings. The material of the water distribution network will be Ductile Iron (DI) of K9 Class. The sand bedding should be provided during laying of the pipelines.

Top of valve chamber covers to have minimum following details -WATER, FSCL/MCF, Year of manufacturing, Water supply pipe/Valve shall be installed as per below table of proposed plan & as per section dwg also.

A. Phase – I, Roads

SR NO	ROAD DESCRIPTION	WATER SUPPLY PIPE SIZE
PROPOSED		
AMBEDHKAR MARG		
1	From NH to Bypass	
	LHS	Replace new pipe of same dia. with existing 250mm DI Water supply (up to lala lajpat rai chowk from NH)
	RHS	Replace new pipe of same dia. with existing 250mm DI Water supply (up to lala lajpat rai chowk from NH)

B. Phase – II, Roads

S No	ROAD DESCRIPTION	WATER SUPPLY PIPE SIZE
1	SECTOR-21 ROAD	
	Internal Road-1	
	LHS	Replacing 200mm dia. pipe having length 320m . Replacing 300mm dia. pipe having length 235m . Replacing 250mm dia. pipe having length 50m .
	Internal Road-2	
	LHS	Replacing 200mm dia. pipe having length 255m . Replacing 250mm dia. pipe having length 160m . Replacing 300mm dia. pipe having length 370m . Replacing 450mm dia. pipe having length 230m .
	RHS	Replacing 100mm dia. pipe having length 360m .
	Sector-21D Dividing Road	
	LHS	Replacing 100mm dia. pipe having length 580m . Replacing 150mm dia. pipe having length 130m . Replacing 200mm dia. pipe having length 950m .
	RHS	Replacing 150mm dia. pipe having length 800m .
	Sector-21B Dividing Road	
	LHS	Replacing 80mm dia. pipe having length 730m . Replacing 100mm dia. pipe having length 390m . Replacing 200mm dia. pipe having length 480m .
	RHS	Replacing 150mm dia. pipe having length 190m . Replacing 200mm dia. pipe having length 380m . Replacing 250mm dia. pipe having length 160m . Replacing 300mm dia. pipe having length 400m .
	Jiva Marg	
	LHS	Replacing 150mm dia. pipe having length 850m .

3.1. SCOPE OF MAINTENANCE OF UTILITY SERVICES:

The Contractor will Operate and Maintain the facilities for duration of five (5) years including defect liability period of 2 years, as per the KPIs defined below. The contractor will provide manpower and spare parts as deemed required at site for O&M of the facilities.

3.2. Key Performance Indicators (KPIs)

This is to clarify that Penalty as indicated in the General Conditions of the Contract will be levied on the contractor only when the E in C finds the "Non Compliance" of the KPIs of the O&M phase, as detailed in the Contract Agreement. The Non Compliance may be due to an act of negligence, improper, un-professional methodology adopted for O&M of the system, by the contractor and/or absence of qualified and experienced man power to be supplied by the contractor, at site.

Maintenance cost shall be included in the contract quotation along with road maintenance

1. The contractor shall submit a Periodic and Routine maintenance plan clearly indicating the frequency of maintenance, turnaround time etc. and have it approved by FSCL.
2. Periodic Maintenance of all types of manholes, including cleaning, inspection of chambers, removing debris if any from time to time and keeping the flow path in good condition so as to ensure smooth flow at all times including rainy season etc. and record shall be kept with Engineer in charge.
3. Inspection of manholes covers, replacing the same if broken or damaged,
4. Attending to choked areas and make it functional immediately on 24 x 7 basis during the maintenance period.
5. Required work force and machinery shall be kept always available.
6. No overflows from the Manholes.
7. Frequency of cleaning of drainage system.
8. Frequency of cleaning of sewers with jetting machine.
9. Frequency of submission of photo inspection along with date for the sewers.
10. Silt removed from the drainage system should be removed by next day from the roadside.
11. Photo inspection along with date to be carried out after removal of silt from the system and submitted to the Employer within a week.
12. The Contractor shall submit a weekly report to the Employer detailing the Operation and Maintenance indicating the labour hours expended, other Consumables consumed, and problems faced and rectified.
13. Record all complaints received and comply with same date and time.
14. Record condition of sewer found at the time of attending complaint. Damage notice should be recorded by attending staff.
15. The Contractor shall carry out mandatory biannual cleaning of network before and after the monsoon season including cleaning of all manhole chambers and collection network irrespective of the regular maintenance work.
16. Minimum time for rectification

SR NO	NATURE OF DEFECT	MINIMUM TIME FOR RECIFICATION
1	Blockage/Leak and overflows	12hours
2	Stolen / Broken man hole covers	12hours
3	Sewer spills from main sewer, branch and house service connections (between property chamber and public	72hours

4.1. LANDSCAPE

4.1.1.SCOPE OF WORK: LANDSCAPE WORKS

The scope of landscape architectural work of smart road includes executing details for hardscape and softscape on the road shoulders and median along with rotary/ green belt where indicated in the drawing.

The hardscape would cover all works with the material specifications on pathways and paved areas, disability access, railing details, barrier kerb/walls, and street furniture. The softscape will be providing, supplying, installation and maintenance for the period of five years, species of trees, palms, shrubs, hedges and groundcover, all plant material given in the BOQ will be executed.

4.1.2.CIVIL WORK:

Work under this Contract shall consist of furnishing all labour, materials, equipment and appliances necessary and required to completely finish including testing and commissioning of all the landscape works including earthworks, civil works, landscape lighting, electrical works, irrigation, drainage, finishing items, etc. and maintenance as specified in the Bill of Quantities and/or shown on the drawings.

Typical design details for the street furniture, their placement will be executed at site.

The interface of the existing road lanes and footpath to the proposed footpath and paved corridor along the road will be integrated.

The underground services will have to be integrated in to the landscape scheme based on the design details provided. All manhole covers, catch basins and electrical works passing through the green/ landscape zone will be coordinated.

The street furniture, on approval of FSCL , such as benches, lighting, waste bins and positioning of the signage, way findings etc. as specified in the BOQ and specifications will be identified in the landscape zone as per plan will be constructed/ installed at site.

- a. Setting out works and carrying out confirmatory survey.
- b. Construction of pathways, ramps, steps, walls, paved sit out areas with finishes as specified and any other civil items as specified in the drawings.
- c. Construction of feature walls, wall benches, supplies and installation of street furniture such as benches, lights, bins etc with external finishes as specified.

The landscape design of road envisages forming a tree lined avenue with shaded spaces for rest areas on the left hand side of the ROW. The right hand side incorporates parking spaces for residents to access the vending zone on the other side. The median incorporates multi coloured hedges cut opposite side glare along with tall palms.

4.1.3.FOOTPATH:

A min 2.40 m wide walkway width to enable pedestrian traffic to walk freely has been proposed. It will have an antiskid vitrified tile floor, coloured interlocking blocks, Stone paving, and granite cut blocks for cobble surfaces as indicated in the drawings. The foot path and the cross overs at intersections will be disable friendly with provision of tactile. It will also incorporate the swale to collect the storm water from the paved area.

4.1.4.GREEN ZONE:

Trees: Planted with large indigenous trees to shade large part of the green shoulder along the walkway. A sincere effort to retain the existing trees and priority of first order to merge with the proposed ones. Trees shall be planted along paved areas to be identified prior to match the the flooring pattern.

Large & Medium shrubs and ground covers will be planted along the edges, where the width is available after due deliberation for the pedestrian's usage is satisfied. The edge will have planters with plants to discourage jay walking, and earmarked vending zones, along with rest areas with benches.

APPLICATION ZONE (Residential Internal Roads)	MATERIALS:
Footpath Finishes	Red Agra sand Stone & kota Stone in polished and rough for flooring. Tactile Flooring in Pedestrian Pathway. Providing for edge block/ kerb at all pathways/ cycle tracks/ tree grate edges. Provision of Drainage scheme all along Footpath as per Detail drawings.
Cycle tracks	Use of color concrete surface. Concrete finish track with signage marked on the floor with hot applied retro-reflective thermoplastic material paints.
Parking Zone	Not applicable
Street Lighting	Street Column Decorative mounted lights, landscape pole lights. Heritage look (triangular form light fixtures over GI Poles as per approved design)
Street Furniture	Benches- Red Sandstone top and cladding as per detail. Red Sandstone Signage of Approximate Size of 8' X 3' for 50 mm thick stone for Signage with Letter Engraving & Linear lights as per detail.
Bollards	Stone Bollards in Red Sandstone or white sandstone as per detail.
Landscape/ Horticulture	Horticulture work includes removing of the Gardens, Toe walls, fencing, ramps above the level as per dwg. pavement in the right of way and developing the green zone on either side of the carriageway. Plantation of Trees/ Shrubs/ Hedges & Ground Covers shall be as per detailed design. Construction of Ramps of Individual owners as per Actual Site Conditions. All Landscaped areas shall be Sloped as per site conditions for Drainage Facility.
Dismantling	All civil and soft landscape not in accordance with the design to be dismantled.

APPLICATION ZONE (Ambedkar Road)	MATERIALS:
Footpath Finishes	Coloured Interlocking Block in approved pattern with Tactile Flooring in Pedestrian Pathway. Providing for edge block/ kerb at all pathways/ cycle tracks/tree grate edges. Provision of Drainage scheme all along Footpath as per Detail drawings.
Cycle tracks	Use of colour concrete surface. Concrete finish track with signage marked on the floor with hot applied retro-reflective thermoplastic material paints.
Parking Zone	Interlocking Block as specified and mentioned in the design drawings
Street Lighting	Street lights of contemporary style, Landscape pole lights, Median lights modern lights, linear floor light in footpath, modern style light
Street Furniture	Benches of Contemporary Style of WPC & Mild Steel Work as per approved design & detail drawings.
Bollards	Stainless Steel bollard
Railings	Mild steel painted and powder coated
Landscape/ Horticulture	Horticulture work includes developing the green zone on either side of the carriageway. Plantation of Trees/ Shrubs/ Hedges & Ground Covers shall be as per detailed design. Medians Shall Include Plantations of palms & Hedges. All Landscaped areas shall be Sloped as per site conditions for Drainage Facility.

APPLICATION ZONE (Link Road)	MATERIALS:
Footpath Finishes	Coloured Interlocking Block in approved pattern with Tactile Flooring in Pedestrian Pathway. Providing for edge block/ kerb at all pathways/ cycle tracks/tree grate edges. Provision of Drainage scheme all along Footpath as per Detail drawings
Cycle tracks	Use of colour concrete surface. Concrete finish track with signage marked on the floor with hot applied retro-reflective thermoplastic material paints.
Street Lighting	Ornamental post top street light along the carriageway.
Street Furniture	Street Furniture includes benches of Jet Black colored rough Granite or local black stone cubes & blocks. Ornamental Signage's shall be provided wherever required.
Bollards	Stone Bollards all along carriageway for Protection of Pedestrian.
Landscape/ Horticulture	Horticulture work includes developing plaza for areas where right of way Permits. Developing Plazas shall include Tree Plantations / Stone Pot Planters & seating areas as per detail drawings. Plantation of Shrubs/ Hedges & Ground Covers as per detailed drawings.

APPLICATION ZONE (Badkhal Mor to Ankheer Chowk)	MATERIALS:
Footpath Finishes	Coloured Interlocking Block in approved pattern with Tactile Flooring in Pedestrian Pathway. Providing for edge block/ kerb at all pathways/ cycle tracks/tree grate edges. Provision of Drainage scheme all along Footpath as per Detail drawings
Cycle tracks	Use of colour concrete surface. Concrete finish track with signage marked on the floor with hot applied retro-reflective thermoplastic material paints.
Street Lighting	Street Column mounted lights, landscape pole lights, linear floor spot lights and .Street Lights
Street Furniture	Benches in WPC material & mild Steel work.
Bollards	Concrete Bollards
Railings	Mild steel painted and powder coated
Landscape/ Horticulture	Horticulture work includes developing green zones on either side of carriage way. Earth Filling for areas for Depressed areas to match design levels as indicated in the Drawings. Dismantling of existing footpath along the road with Avenue Plantations all along the carriageway with Shrubs/ hedges & Ground Covers. Avenue Plantation all along the carriageway.

APPLICATION ZONE (Ankheer Chowk to Badkhal Chowk)	MATERIALS:
Footpath Finishes	Coloured Interlocking Block in approved pattern with Tactile Flooring in Pedestrian Pathway. Providing for edge block/ kerb at all pathways/ cycle tracks/tree grate edges. Provision of Drainage scheme all along Footpath as per Detail drawings
Cycle tracks	Use of colour concrete surface. Concrete finish track with signage marked on the floor with hot applied retro-reflective thermoplastic material paints.
Street Lighting	Tree form Street Lights, low Height Bollards, Tree uplighters & Ground Burials.
Street Furniture	Benches in WPC material & mild Steel work.
Bollards	Concrete Bollards
Railings	Mild steel painted and powder coated

APPLICATION ZONE (Ankheer Chowk to Badkhal Chowk)	MATERIALS:
Landscape/ Horticulture	Horticulture work includes developing green zones on either side of carriage way. Earth Filling for areas for Depressed areas to match design levels as indicated in the Drawings. Carriage way with Avenue Plantations all along the carriageway with Shrubs/ hedges & Ground Covers. Plantation of flowering Trees all along the Median as avenue Plantation.

APPLICATION ZONE (Talab road without median)	MATERIALS:
Footpath Finishes	Coloured Interlocking Block in approved pattern with Tactile Flooring in Pedestrian Pathway. Providing for edge block/ kerb at all pathways/ cycle tracks/tree grate edges. Provision of Drainage scheme all along Footpath as per Detail drawings
Cycle tracks	Use of colour concrete surface. Concrete finish track with signage marked on the floor with hot applied retro-reflective thermoplastic material paints.
Street Lighting	Street Column mounted lights, landscape pole lights, linear floor or spot lights and street lights
Street Furniture	Street Furniture includes benches of Jet Black colored rough Granite or local black stone cubes & blocks. Ornamental Signage's shall be provided wherever as per detailed design.
Bollards	Stone Bollards
Railings	Mild steel painted and powder coated
Landscape/ Horticulture	Horticulture work includes developing green zones on either side of carriage way. Carriage way with Avenue Plantations all along the carriageway with Shrubs/ hedges & Ground Covers.

APPLICATION ZONE (Talab road with median)	MATERIALS:
Footpath Finishes	Coloured Interlocking Block in approved pattern with Tactile Flooring in Pedestrian Pathway. Providing for edge block/ kerb at all pathways/ cycle tracks/tree grate edges. Provision of Drainage scheme all along Footpath as per Detail
Cycle tracks	Use of colour concrete surface. Concrete finish track with signage marked on the floor with hot applied retro-reflective thermoplastic material paints.
Street Lighting	Ornamental post top street light
Street Furniture	Street Furniture includes benches of Jet Black colored rough Granite or local black stone cubes & blocks. Ornamental Signage's shall be provided wherever required.
Bollards	In concrete
Landscape/ Horticulture	Horticulture work includes developing green zones on either side of carriage way. Carriage way with Avenue Plantations all along the carriageway with Shrubs/ hedges & Ground Covers.

APPLICATION ZONE (21D Internal road)	MATERIALS:
Footpath Finishes	60mm thick Interlocking Paver blocks Block with Tactile Flooring in Pedestrian Pathway. Providing for edge block/ kerb at all pathways/ cycle tracks/ tree grate edges & Tree Guards. Provision of Drainage scheme all along Footpath as per Detail drawings.
Cycle tracks	Use of colour concrete surface. Concrete finish track with signage marked on the floor with hot applied retro-reflective thermoplastic material paints.
Parking Zone	Not applicable

APPLICATION ZONE (21D Internal road)	MATERIALS:
Street Lighting	Street Column Decorative mounted lights, landscape pole lights. Heritage look (triangular form light fixtures over GI Poles as per approved design)
Street Furniture	Precast Concrete Reinforced Bench. The Bench consists of grey cement color of thickness - 100mm, back light - 1000mm & front height - 450mm, base width - 620mm, manufactured by using M-40 Grade of Concrete & reinforced suitable to prevent damage during handling, transportation, erection & long use.
Bollards	Rugged concrete bollards 1000mm tall that cannot be vandalized or moved will be used in heavy traffic pedestrian zones and cycle tracks to minimise conflict with cars and motorbikes
Landscape/ Horticulture	Horticulture work includes removing of the Gardens, Toe walls, fencing, ramps above the level as per dwg, pavement in the right of way and developing the green zone on either side of the carriageway. Plantation of Trees/ Shrubs/ Hedges & Ground Covers shall be as per detailed design. Construction of Ramps of Individual owners as per Actual Site Conditions. All Landscaped areas shall be Sloped as per site conditions for Drainage Facility.
Dismantling	All civil and soft landscape not in accordance with the design to be dismantled.

APPLICATION ZONE (Road No 1.)	MATERIALS:
Footpath Finishes	60 MM thick Paver Block of Size 100 X 200 MM, Color: combination of red and beige pavers as / pattern Tactile Flooring in Pedestrian Pathway. Providing for edge block/ kerb at all pathways/ cycle tracks/tree grate edges. Provision of Drainage scheme all along Footpath as per Detail drawings.
Cycle tracks	Use of colour concrete surface. Concrete finish track with signage marked on the floor with hot applied retro-reflective thermoplastic material paints.
Parking Zone	Interlocking Block as specified and mentioned in the design drawings
Street Lighting	Street lights of contemporary style, Landscape pole lights, Median lights modern lights, linear floor light in footpath, modern style light
Street Furniture	Precast Concrete Reinforced straight bench with back of size - 60"x24", front height-18" and thickness-4", Colour- red, manufactured by using M-40 Grade of Concrete & reinforced suitable to prevent damage during handling, transportation, erection & long use. All parts are joined together with galvanized nuts & bolts of suitable size.
Bollards	Rugged concrete bollards 1000mm tall that cannot be vandalized or moved will be used in heavy traffic pedestrian zones and cycle tracks to minimise conflict with cars and motorbikes
Landscape/ Horticulture	Horticulture work includes developing the green zone on either side of the carriageway. Plantation of Trees/ Shrubs/ Hedges & Ground Covers shall be as per detailed design. Medians Shall Include Plantations of palms & Hedges. All Landscaped areas shall be Sloped as per site conditions for Drainage Facility.

APPLICATION ZONE (Road No 2.)	MATERIALS:
Footpath Finishes	60 MM thick Paver Block of Size 100 X 200 MM, Color: combination of red and beige pavers as / pattern Tactile Flooring in Pedestrian Pathway. Providing for edge block/ kerb at all pathways/ cycle tracks/tree grate edges. Provision of Drainage scheme all along Footpath as per Detail drawings.
Cycle tracks	Use of colour concrete surface. Concrete finish track with signage marked on the floor with hot applied retro-reflective thermoplastic material paints.
Street Lighting	Ornamental post top street light along the carriageway.

APPLICATION ZONE (Road No 2.)	MATERIALS:
Street Furniture	Precast Concrete Reinforced straight bench without back of size - 66"x18" and weight 140 kg,Color- white , manufactured by using M-40 Grade of Concrete & reinforced suitable to prevent damage during handling,transportation, erection & long use.
Bollards	Rugged concrete bollards 1000mm tall that cannot be vandalized or moved will be used in heavy traffic pedestrian zones and cycle tracks to minimise conflict with cars and motorbikes
Landscape/ Horticulture	Horticulture work includes developing plaza for areas where right of way Permits. Developing Plazas shall include Tree Plantations / Stone Pot Planters & seating areas as per detail drawings. Plantation of Shrubs/ Hedges & Ground Covers as per detailed drawings.

APPLICATION ZONE (Sector 21B Road)	MATERIALS:
Footpath Finishes	60 mm thick paver block size:150 x 150 mm, material: precast pcc, finish: shotblasted) laid to pattern as indicated.
Cycle tracks	Use of colour concrete surface. Concrete finish track with signage marked on the floor with hot applied retro-reflective thermoplastic material paints.
Street Lighting	Street Column mounted lights, landscape pole lights, linear floor or spot lights
Street Furniture	Precast Concrete Reinforced straight bench with back of size - 18"x32"x48" and weight 215 kg,Color- yellow, manufactured by using M-40 Grade of Concrete & reinforced suitable to prevent damage during handling, transportation, erection & long use. All parts are joined together with galvanized nuts & bolts of suitable size
Bollards	Rugged concrete bollards 1000mm tall that cannot be vandalized or moved will be used in heavy traffic pedestrian zones and cycle tracks to minimise conflict with cars and motorbikes
Landscape/ Horticulture	Horticulture work includes developing green zones on either side of carriage way. Earth Filling for areas for Depressed areas to match design levels as indicated in the Drawings. Dismantling of existing footpath along the road with Avenue Plantations all along the carriageway with Shrubs/ hedges & Ground Covers. Avenue Plantation all along the carriageway.

APPLICATION ZONE (Jiva Marg)	MATERIALS:
Footpath Finishes	60 mm thick paver block size:100 x 200 mm, color: combination of black and red pavers as / pattern material:precast pcc,finish: shotblasted. laid to pattern as indicated. bedded on 50mm thk. sand bed as/specs. . Providing for edge block/ kerb at all pathways/ cycle tracks/tree grate edges. Provision of Drainage scheme all along Footpath as per Detail drawings.
Cycle tracks	Use of colour concrete surface. Concrete finish track with signage marked on the floor with hot applied retro-reflective thermoplastic material paints.
Street Lighting	Tree form Street Lights, low Height Bollards, Tree uplighters & Ground Burials.
Street Furniture	Precast Concrete Reinforced straight bench without back of size - 60"x18"x18" ,Color- wood brown with white legs, manufactured by using M-40 Grade of Concrete & reinforced suitable to prevent damage during handling, transportation, erection & long use.

Bollards	Rugged concrete bollards 1000mm tall that cannot be vandalized or moved will be used in heavy traffic pedestrian zones and cycle tracks to minimise conflict with cars and motorbikes
Landscape/ Horticulture	Horticulture work includes developing green zones on either side of carriage way. Earth Filling for areas for Depressed areas to match design levels as indicated in the Drawings. Carriage way with Avenue Plantations all along the carriageway with Shrubs/ hedges & Ground Covers. Plantation of flowering Trees all along the Median as avenue Plantation.

APPLICATION ZONE (NH 2 SERVICE ROAD)	MATERIALS:
Footpath Finishes	Use of 60MM thick paver Block for footpath and 80mm thick grass paver block of size 600x600mm for parking. Tactile Flooring in Pedestrian Pathway. Providing for edge block/ kerb at all pathways/ cycle tracks/tree grate edges. Provision of Drainage scheme all along Footpath as per Detail drawings.
Cycle tracks	Use of colour concrete surface. Concrete finish track with signage marked on the floor with hot applied retro-reflective thermoplastic material paints.
Street Lighting	Street Column mounted lights, landscape pole lights, linear floor or spot lights
Street Furniture	Precast Concrete Reinforced straight bench with back of Size - 72"x16" and 18" high ,Color- grey, manufactured by using M-40 Grade of Concrete & reinforced suitable to prevent damage during handling, transportation, erection & long use. All parts are joined together with galvanized.
Bollards	Rugged concrete bollards 1000mm tall that cannot be vandalized or moved will be used in heavy traffic pedestrian zones and cycle tracks to minimise conflict with cars and motorbikes
Landscape/ Horticulture	Horticulture work includes developing green zones on either side of carriage way. Carriage way with Avenue Plantations all along the carriageway with Shrubs/ hedges & Ground Covers.

APPLICATION ZONE (Main bandh road)	MATERIALS:
Footpath Finishes	Main bandh road of 60mm thick paver block of size 100 x 100mm Precast PCC laid to pattern as indicated in the drawing.
Cycle tracks	Use of colour concrete surface. Concrete finish track with signage marked on the floor with hot applied retro-reflective thermoplastic material paints.
Street Lighting	Ornamental post top street light
Street Furniture	Precast Concrete Reinforced Bench- Dimensions: Sitting Platform size - 2825mm length X 400 mm width X 50mm Thickness; Leg size - 400mm Height X 400mm Width X 80/55mm thickness; Sitting height is 450 mm. Sitting Platform is in Red colour while the legs are in grey colour. Manufactured by using M-30 grade of Concrete. Suitably reinforced to promote long use and to prevent damage during handling, transportation & erection. Treated with special anti-corrosive, water proof coating so as to make the surface glossy and water proof
Bollards	Rugged concrete bollards 1000mm tall that cannot be vandalized or moved will be used in heavy traffic pedestrian zones and cycle tracks to minimise conflict with cars and motorbikes
Landscape/ Horticulture	Horticulture work includes developing green zones on either side of carriage way. Carriage way with Avenue Plantations all along the carriageway with Shrubs/ hedges & Ground Covers.

APPLICATION ZONE (Bidhuri Marg)	MATERIALS:
Footpath Finishes	60mm thick paver block of size 100 x 100mm Precast PCC finish shot blasted laid to pattern as indicated in the drawing.
Cycle tracks	Use of colour concrete surface. Concrete finish track with signage marked on the floor with hot applied retro-reflective thermoplastic material paints.
Street Lighting	Ornamental post top street light
Street Furniture	Precast Concrete Reinforced straight bench with back of size - 18"x32"x48" and weight 215 kg, Color- yellow, manufactured by using M-40 Grade of Concrete & reinforced suitable to prevent damage during handling, transportation, erection & long use. All parts are joined together with galvanized nuts & bolts of suitable size
Bollards	Rugged concrete bollards 1000mm tall that cannot be vandalized or moved will be used in heavy traffic pedestrian zones and cycle tracks to minimize conflict with cars and motorbikes
Landscape/ Horticulture	Horticulture work includes developing green zones on either side of carriage way. Carriage way with Avenue Plantations all along the carriageway with Shrubs/ hedges & Ground Covers.

APPLICATION ZONE (ITI ROAD)	MATERIALS:
Footpath Finishes	60mm thick paver block of size 100 x 100mm Precast PCC finish shot blasted laid to pattern as indicated in the drawing.
Cycle tracks	Use of colour concrete surface. Concrete finish track with signage marked on the floor with hot applied retro-reflective thermoplastic material paints.
Street Lighting	Ornamental post top street light
Street Furniture	Precast Concrete Reinforced straight bench without back of size - 60"x18"x18" ,Color-white, manufactured by using M-40 Grade of Concrete & reinforced suitable to prevent damage during handling, transportation, erection & long use.
Bollards	Rugged concrete bollards 1000mm tall that cannot be vandalized or moved will be used in heavy traffic pedestrian zones and cycle tracks to minimize conflict with cars and motorbikes
Landscape/ Horticulture	Horticulture work includes developing green zones on either side of carriage way. Carriage way with Avenue Plantations all along the carriageway with Shrubs/ hedges & Ground Covers.

APPLICATION ZONE (Railway Road)	MATERIALS:
Footpath Finishes	60mm thick paver block of size 100 x 100mm Precast PCC finish shot blasted laid to pattern as indicated in the drawing.
Cycle tracks	Use of colour concrete surface. Concrete finish track with signage marked on the floor with hot applied retro-reflective thermoplastic material paints.
Street Lighting	Ornamental post top street light
Street Furniture	Precast Concrete Reinforced Bench around pillars with size:1200 mm X 1000 mm X 50 mm Reinforced suitably to promote long use to (Thickness) height: 450mm.Prevent damage during handling. Manufactured by using an M-30 grade of transportation erection long use. Bench top is treated with a special anti-corrosive waterproof coating as to make surfaces glossy or terrazzo finish.
Bollards	Rugged concrete bollards 1000mm tall that cannot be vandalized or moved will be used in heavy traffic pedestrian zones and cycle tracks to minimize conflict with cars and motorbikes

APPLICATION ZONE (Railway Road)	MATERIALS:
Landscape/ Horticulture	Horticulture work includes developing green zones on either side of carriage way. Carriage way with Avenue Plantations all along the carriageway with Shrubs/ hedges & Ground Covers.

APPLICATION ZONE (Station Road)	MATERIALS:
Footpath Finishes	60mm thick paver block of size 100 x 100mm Precast PCC finish shot blasted laid to pattern as indicated in the drawing.
Cycle tracks	Use of colour concrete surface. Concrete finish track with signage marked on the floor with hot applied retro-reflective thermoplastic material paints.
Street Lighting	Ornamental post top street light
Street Furniture	Precast Concrete Reinforced straight bench without back of size - 66"x18", height-18", thickness-4" and weight 140 kg, Color- red ,with 3 no's of reinforced concrete planks in red color of size 66" X 6"mm X 4",manufactured by using M-40 Grade of Concrete & reinforced suitable to prevent damage during handling, transportation, erection & long use. All parts are joined together with galvanized
Bollards	Rugged concrete bollards 1000mm tall that cannot be vandalized or moved will be used in heavy traffic pedestrian zones and cycle tracks to minimize conflict with cars and motorbikes
Landscape/ Horticulture	Horticulture work includes developing green zones on either side of carriage way. Carriage way with Avenue Plantations all along the carriageway with Shrubs/ hedges & Ground Covers.

5.1. HORTICULTURE

Work under this Contract shall consist of furnishing all labour, materials, equipment and appliances necessary and required to completely finish including testing and commissioning of all the landscape works including plantation of trees, shrubs, groundcovers, palms, climbers, etc. and maintenance as specified in the Bill of Quantities and/or shown on the drawings.

The planting work shall include but not be limited to the following:

- a. Provide for all plant material as per the BOQ
- b. Provide labour, equipment, services and transport.
- c. Provide planting soil from approved source.
- d. Provide topsoil for all plants.
- e. Provide fertilizers, chemicals and manure and stakes as specified.
- f. Prepare and stake out all planting locations.
- g. Prepare plants pits, back filling; prepare "sources" for watering, adding soil after settlement.
- h. Spraying insecticides as required, before planting.
- i. Staking, supporting, wrapping and tying all major trees and shrubs.
- j. Transplanting, if any
- k. Disposal of debris and unused materials.
- l. Guarantee of trees and plants for a period of twelve months.
- m. Provide necessary labour and staff for maintenance work for 60 months.

5.2. PLANT MATERIALS/LAWNS

(a) **Area:** all exterior ground area, except surfaces occupied by structures and paving as well as areas indicated to be undisturbed or planted (trees, shrubs, ground covers, creepers, vines, annual plants, etc.), shall be planted as shown on drawing.

(b) Materials

1. Top soil shall be fertile, friable, natural topsoil typical of locality, and shall be obtained from a well-drained site that is free of flooding. It shall be without admixture of subsoil or slag and shall be free of stones, lumps, plants or their roots, stics and other extraneous matter and shall not be delivered or used while in a frozen or muddy condition.
2. Top soil as delivered to the site shall have an acidity range of PH 6.5 to 7.5 and shall not contain less than 5% organic matter. Sufficient horticulture grade lime shall be added to topsoil to bring it to a range of PH 6.5 to 7.5.

(c) Ground Preparation

1. **Grading** - Grade lawn areas to finish grades, filling as needed or removing surplus dirt and floating areas to a smooth, uniform grade as indicated. All lawn areas shall slope to drain. Where no grades are shown, areas shall have a smooth and continual grade between existing contours (such as walks, curbs, catch basin, elevation at steps or building) and elevation shown on plans. roll, scarify, rake and level as necessary to obtain true, even lawn surfaces, all finish grades shall meet approval of the Landscape Architect or his authorized representative, before lawn is laid.
2. Chemical fertilizer shall be spread on areas to be seeded at the rate of 20 lbs. per 100 square feet. The fertilizer shall be 50% organic and shall be applied from a suitable spreader.

3. Natural fertilizer-manure shall be well un-leached, Okhla khad or cattle manure free from sawdust shavings, refuse and harmful chemicals, manure shall contain no lumps which will not pass a 2 inch sieve. Spreading of 1 inch thick layer of manure on the ground and mixing with the good earth.
4. After incorporation of fertilizer in the soil, the lawn bed, shall be fine graded to remove all ridges and depressions, and surface cleared of all stones 1 inch or more in diameter and of other debris. At least 1 inch layer of manure to be spread on the ground and mix with earth for grassing. Ref. given specification for lawn bed preparation.
5. Planting of rooted cuttings grass at a regular distance of 5cm centre to centre. After 15 days 1st mowing should be done. Or Laying grass carpet directly on prepared ground.

(d) Lawn Maintenance

1. Maintenance shall consist of watering, weeding, fertilizing, liming, disease and pest control, aerating, protective spraying, replacement of unacceptable material and any other procedure consistent with good horticulture practice necessary to ensure normal, vigorous and healthy growth of all planted area.
2. For the first 30 days, it requires approximately 500 gallons of water for every 100 square feet every day for each application to penetrate the soil to a depth of 4 to 6 inches. After the, same quantity of water shall be applied on alternate dates.
3. Keep all planting areas free from weeds and undesirable grasses.
4. Mow all grass areas at regular intervals which will keep grass height from exceeding 2.5 inches. Remove all grass clippings during or immediately after mowing.
5. Maintenance shall also include all temporary protection fences, barriers and signs and all other work incidental to proper maintenance.

5.3. PLANT MATERIAL A. TREES, SHRUBS, GROUND COVERS, CREEPERS, VINES, ETC.

- (a) Plant List - Plants are listed in the drawings; the plant list is enclosed herein.
- (b) Nomenclature - The names of the plants confirm to standardize botanical names.
- (c) Quality and General Requirements of Plants.
 1. Plants shall be typical of their species and variety, have normal growth habits, well developed branches, densely foliated with vigorous and fibrous root systems.
 2. Plants shall be free from defects and injuries. Bark shall be free from abrasion.
 3. Plants shall be freshly dug and nursery grown. Plants shall have been grown under climatic conditions similar to those of the locality of project, or have been acclimated for at least 2 years to conditions of project location. Nursery grown plants shall have been at least once transplanted.
 4. Each bundle of plants and all separate plants shall be properly identified by weatherproof labels securely attached there to before delivery to project site.
 5. B & B (Balled and Burlap) plants must be moved with the root system as solid units in balls of each firmly wrapped with burlap, The diameter and depth of the balls of earth must be sufficient to encompass the fibrous and feeding root system necessary for the healthy development of the plant. No plant shall be used when the ball of earth surrounding its roots have been badly cracked or broken preparatory to or during the process of planting or after the equipment required in connection with its transplanting has been removed. The plant and ball shall remain intact as one unit during all operations.
 6. Container grown stock shall have been grown in container long enough for the root system to have developed sufficiently to hold its soil together, firm and whole. No plant shall be loose in container.

7. All plants shall be readied under climatic conditions similar to those in the locality of the project. When plants of kinds or sizes specified are not available substitution may be made upon request by the Contractor if approved by the Landscape Architect.
8. All trees, soon after planting shall be properly supported to ensure their safety against wind or other factors which may effect it adversely. A minimum of 3 stakes per tree shall be provided by the contractor.

(d) Size of Plants

1. All plant shall be equal to or exceed the sizes given in the plant list, which are minimum acceptable sizes. Plants shall be measured before planting, with branches in normal position.
 2. Trees shall be minimum length as specified and shall be straight and symmetrical with a crown and having a persistent main stem. The size of the crown shall be in good overall proportion to the height of the tree shall be measured from the top of the root ball or pot. In case of palms, height will be measured from top of root ball to the point of branching of leaves.
 3. Shrubs shall be well formed with a crown typical of the species and variety. Shrub height dimension shall be the average height of the all stems and not of longest stem.
- (a) Medium & small shrubs bed - 0.45m depth of bed and in case of individual shrubs, 0.60 dia and 0.60 depths.
 - (b) Ground Cover bed - The bed shall be dug a depth of 20 cms,
 - (c) Topsoil shall be made ready for planting before plants are delivered to the site. The pits/beds shall be given anti-termite treatment before back filling.
 - (d) Placing of plants - Plants shall be centre of pits plumb and straight.
 - (e) Final Considerations - Topsoil shall be compacted around basin of balls to fill all voids. Roots shall be properly spread out and topsoil carefully worked in among them.
 - (f) Watering - Immediately after plant pit is back filled, a shallow base slightly larger than pit shall be formed with a ridge of soil to facilitate and contain watering. After planting, cultivate the soil between plant pit and rake smooth. Spray the soil with water to settle.

5.4. AFTER PLANTING CARE

- (a) Watering - Water trees and other plants by flooding twice within first 24 hours of the time of planting. Tree requires 6 gallons per plant per day for first 45 days from the date of planting and subsequently every alternate day for the next 6 months. Thereafter watering twice a week at the rate of 10 gallons per plant.

5.5. GUARANTEE

- (a) Period All plants and lawns shall be guaranteed by the contractor for 12 (twelve) months after the certified date of completion.
- (b) Conditions During this period, any plant that is found missing, dead or not true to name or size as specified, or not in satisfactory growth shall be replaced immediately with approved size and shape.
- (c) Replacement - All replacements shall be plants of the same species, variety and size as specified in the plant list. The cost of replacement resulting from removal, loss or damage due to the occupancy of the project in any part, or vandalism or acts of neglect on the part of others, in which case the cost will be borne by the clients.

6.1. STREET FURNITURE AND LIGHTING

Street furniture and lighting equipment have a major impact on the appearance of street and will be planned as part of the overall design concept.

6.2. STREET FURNITURE:

- (a) Street furniture will be integrated into the overall appearance of a street. Particular attention is paid to the aesthetic quality of street furniture and lighting.
- (b) Street furniture that encourages human activity can also contribute to a sense of place.
- (c) Street furniture of direct benefit to street users, particularly seating, is encouraged but should be sympathetic to the design of the street and respect pedestrian desire lines.
- (d) Seating to provide rest points for pedestrians, particularly those with mobility or visual impairments.
- (e) Extra seating has been considered where people congregate, such as vending kiosks, squares, local shops and schools.
- (f) Seating can sometimes attract anti-social behaviour and therefore should be located where there is good lighting and natural surveillance.
- (g) Street furniture, including lighting columns and fittings, will be resistant to vandalism and placed in positions that minimize risk of damage by vehicles.
- (h) Street furniture will be aligned on footways, preferably at the rear edge in order to reduce clutter.
- (i) All street furniture should be placed to allow access for street cleaning.
- (j) Guard railing will be installed to restrict the movement of vulnerable road users. It will be necessary to introduce barriers to pedestrian movement.

6.3. MAINTAINANCE:

- The Scope of Work in Operation & Maintenance includes but not limited to the followings:
 - a. Deployment of required labors,
 - b. Watering the Landscaped Areas
 - c. Putting the lurches
 - d. Trimming the plants/shrubs & Ground Covers in the shape as instructed by E in C
 - e. Repair and / or replacement of materials,
 - f. Painting of grills & Pot Planters
 - g. Maintenance of Horticulture Works
 - h. Cleaning / Replacement of benches and statues, art, or any other panels, equipment's.
 - i. Repair or Replacement of Light Fixture as Required.
 - j. The Contractor shall make arrangement of Water for Horticulture Work.
 - k. Replacement of Planter Pots on Breakage or damage

All dead plant shall be replaced with plant of the same quality, specifications and of the present age of the plant to be replaced to the Satisfaction of the Engineer-in –charge (i.e. Age of the planted tree on the date of plantation plus period from date of planting to the date of replacement of the plant)

The contractor shall spray/spread of the followings with minimum quantity per month mentioned below.

- a. Urea/Ammonium Sulphate (30 gm/sqm)
- b. Bone Meal (150 gm/sqm)
- c. Potassium Sulphate or Murate of Potash (20gm/sqm)
- d. Insecticides (10 ml in 10 Liter water/sqm)
- e. DAP
- f. Pesticides (10 ml in 10 Liter water/sqm)
- g. Manure (1 cum /100 Sqm)

All leaf falls, branches, twigs, cut grass after mowing shall be deposited in layers in the compost pit. Care should be taken to cover the compost pit with grill and process for making compost shall be done by contractor.

The contractor shall manage/operate the compost pit as per relevant Standard and guidelines. Any other debris, fallen trees for whatsoever reason shall be dispose off at designated locations as instructed by Engineer –In-Charge.

The Contractor shall deploy the security guards round the clock (24x7) for managing the landscaped area. The contractor shall be also be responsible to protect all the assets of the places where work is to be executed including protection of damage or theft of IT and other infrastructures and equipment's.

In case of any damage/theft occurs during the O & M period it shall be borne by the contractor.

The contractor shall maintain all planted areas within the landscape contract boundaries for five year from the date of handing over of the complete area. (Until the area is handed over in whole or in phases). The handover date shall be considered from the date of issue of completion certificate.

Maintenance shall include replacement of dead plants, watering, weeding, cultivating, control of insects, fungus and other diseases by means of spraying with an approved insecticide or fungicide, pruning, and other horticulture operations necessary for the proper growth of the plants and for keeping the landscape contract area neat in appearance.

All the under performing plants shall also be replaced with the healthy plants of the same quality and specifications as described above for dead plants .However if Engineer In charge is convinced and feels that the underperforming plants can perform better during the balance period from the maintenance period of five years then the contractor may get this relaxation up to the completion of the maintenance period but at the end he has to replace all the underperforming plants with the healthy plants having same height and specification of the same type of plant grown in the area or as specified above for dead plants.

After the completion of defect liability period of one year the minimum heights of all the planted trees shall be as described below:

- a. 80% of the trees should be between 8 feet to 10 feet height.
- b. 10% of the trees should be between 6 feet to 8 feet height.
- c. Rest of the trees shall be between the specified height (i.e.in the BOQ description of item) to 6 feet
- d. Shrubs & Hedges to be thick & height shall be as per mentioned in the Drawings & BOQ.
- e. Ground Covers shall have Carpet Effect. No soil shall be visible.
- f. Paving Pattern shall be as per pattern in the Drawings.

- Submit an O & M Plan, Manual, and Literature to FSCL

6.4. Debris

Do not permit debris or unsalvageable material resulting from the work to accumulate on the site

Remove debris as rapidly as it accumulates

Do not dispose of material on property without the authorized consent of the site manager designee - provide for off-site disposal areas

Contractor is to keep the work area clean at all times and shall promptly remove waste materials or rubbish contractor's responsibilities.

Trees, shrubs, flowers or turf that are damaged or killed due to the contractors operations, chemicals, irrigation failure, or negligence shall be replaced at no expense to the owner

6.5. Pruning and repairs:

Upon completion of planting work under the contract, all shrubs/ hedges should be pruned and all injuries repaired where necessary. The amount of pruning shall be limited to the minimum necessary to remove dead or injured twigs and branches and to compensate for the loss of roots and result of transplanting operations. Pruning shall be done in such a manner as not to change the natural habitat or special shape of the trees.

6.6. Nursery Stock:

Planting should be carried out as soon as possible after reaching the site. Where planting must of necessity be delayed, care should be taken to protect the plants from pilfering or damage from people or animals. Plants with bare roots should be heeled – in as soon as received or otherwise protected from drying out and others set closely together and protected from the wind. If planting is to be delayed for more than a week, packed plants should be unpacked, the bundles opened up and each group of plants heeled in separately and clearly labelled. If for any reason the surface of the roots becomes dry the roots should be thoroughly soaked before planting.

6.7. Protective fencing:

According to local environment, shrubs shall be protected adequately from vandalism until established.

6.8. Potted Plants:

The potted plants beds to be maintained by planting summer & winter seasonal plants. Seed/seedlings should be provided by the contractors.

6.9. Plantation of Seasonal Flowers

Preparation of seasonal flower beds plants, seeds etc. shall be at contractors cost and as directed by officer in charge. The Seasonal Flowers shall be planted twice in a year. (In summer & Winter Season)

6.10. **Completion:** On completion, the ground shall be formed over and left tidy.

6.11. **Work Force** – The work Force shall be as follows.

Operation & Maintenance (For Horticulture Works)

S. No.	Position/Qualification	Nos. to be deployed
1	Sr. horticulturist – Degree (agri/ horti) holders with minimum experience of 3 years in the field.	1
2	Sr. Gardener (Mali): minimum experience of 4 years in the field.	4

Below is the list of items for which penalty shall be incurred against repetitive items which are to be maintained for the Landscaped area Under each intersection. Inspection/ Audit shall be done periodically to keep a check on the maintenance of the Landscaped Area. Penalty shall be incurred against below mentioned items for non-compliance for maintenance of horticulture items as per the below table.

Sl. No	Nature of service	Maintenance Activity	Time Span	Time Span allotted for restoration	Penalty Amount (To be deducted per intersection after time Span restoration)
A	Watering	Watering the whole area of lawns/garden, turfs, flower beds/ shrubs ground covers etc under the contract daily at the rate of 4 to 5 liters per sqm area, uniformly, using all tools and tackles like rubber hose, sprinkler. Water will be made available at watering points.	Daily	-	Rs 600 /day
2	Trimming				
A	Shrubs/ Hedges	All overgrown Shrubs & hedges shall be periodically trimmed once in 4 weeks.	Feb - July	1 Week	Rs 1000 per week
		All overgrown Shrubs & hedges shall be periodically trimmed once in 8 weeks.	July-Jan	1 Week	
B	Ground Covers	Trimming of Ground covers & removal of unwanted plants for 2 weeks	Feb - July	1 Week	Rs 1000 per week
		Trimming of Ground covers & removal of unwanted plants for 4 weeks	July-Jan	1 Week	
C	Hardscape	All hardscape elements like Pathways in Interlocking Block, disposal of rubbish etc. shall be reviewed on daily basis for any repair work if necessary.	Daily	2 days	Rs 600 for every item
D	Railing	Grills / Railings to be protected & welded / re-erected/ repaired on urgent basis.	As Required	4 Days	Rs. 500/ day
E	Light Fixtures & Street Poles	Luminaries to be replaced/ repaired when required.	As Required	7 days	Rs. 500/ Light
Contractor shall maintained the landscaped area as per scope for maintenance, if failure of maintenance will attract penalty as per prorata basis or as directed by engineer in charge.					

7.1. ELECTRICAL WORK: SCOPE OF WORK FOR ELECTRICAL

7.1.1.General:

The existing and the proposed HT and LT lines are under DHBVN.

The Contractor have to work in consultation and supervision of both FSCL and DHBVN.

The Maintenance shall be for Five Years with a defect liability of two years.

The contractor shall refer to the conditions provided in the General and Special Condition of Contract.

7.1.2.Broad classification of Activities involved:

1. Supply, Installation, Testing and Commissioning of new H poles with accessories for converting existing overhead lines to cables
2. Construction of utility duct on both sides of the Road with provision of openings and sleeves for incoming/outgoing LT/HT cables, manholes at an interval of 10 mtr throughout the duct and at location of road crossing of cable etc.
3. Installation of cable trays with supports in cable trenches
4. Arrangement for 'Direct buried cable Laying System' for all the HT as well as LT cables as per Indian standard/ DHBVN norms wherever necessary.
5. Provision of HDPE pipes for road crossing for LT/HT cable.
6. Installation of structure with cable trays and its supports for road crossing of cables on Ambedkar Road.
7. Construction of appropriate size of pit for cables laying and bending under ground near steel structure installed for overhead road crossing of cables.
8. Supply, Installation, Testing and Commissioning of HT cables on cable trays/pipe/with direct buried method and termination at H pole frames / 11 kV Distribution Transformer(DT)/ outdoor Ring Main Units/ Isolator module etc.
9. Supply, Installation, Testing and Commissioning of LT cables on cable trays/ by Direct buried method and through pipes.
10. Provision for 11KV Ring System/ backup system in coordination with DHBVN.
11. Supply, Installation, Testing and Commissioning of 11 kV / 433 V Distribution Transformer(DT), outdoor Ring Main Units and non- extensible 2 module set (Direct Cable Incoming Module and Load Break Switch Module for outgoing cable) hence forth called as Isolator module set etc.
12. Supply, Installation, Testing and Commissioning (T & C) of Feeder Pillars
13. Laying and Termination of LT cables up to Feeder pillars
14. Undergrounding of all HT (11kV) and LT cables from the road to improve aesthetic look of the road and make it overhead wire free.
15. Supply, Installation, Testing and commissioning of 'Street lighting system with provision of remote communication' and 'landscape lighting system'.
16. Supply, Installation, Testing and commissioning of cabling and earthing system for Street lighting and landscape lighting.
17. Provision of Earthing system.
18. Construction of foundation for all electrical items as per size and weight of the equipment.

19. Dismantling and removal of existing infrastructure

7.1.3.Scope of work

- (i) Dismantling, removal and transporting all components of existing overhead lines, poles, transformers, LT panels and meters to DHBVN designated place.
- (ii) Dismantling, removal and transporting all components of existing street lighting to DHBVN designated place.
- (iii) Supply, Installation, Testing & Commissioning of H Pole structures with accessories at required locations where 11kV overhead lines are to be converted to underground cables. This includes excavation, civil foundations, GI channels, Gang operating Disconnects (GOD), insulators etc.
- (iv) All existing 11kV overhead lines on ABD roads including those crossing the road shall be converted to underground cable circuits and terminated on H structure /Transformer/ RMU of 11 kV / outdoor Ring Main Units/ Isolator module sets etc. as per site requirements. This includes necessary jumper work required on H poles also.
- (v) Supply and erection of Cable trays for HT/LT power cables with necessary supports and accessories.
- (vi) Erection of Cable trenches for HT/LT power cables with necessary accessories i.e. bricks, concrete cover etc..
- (vii) Supply, Installation, Testing & Commissioning of LT/ HT cables by Direct buried system/ through HDPE pipes/ on cable trays with end terminations.
- (viii) Provision of outdoor Isolator unit for arrangement of 11kV ring/backup facility in co-ordination with DHBVN.
- (ix) Laying and termination of HT cable for Ring/Backup feeder (Feeder confirmed by DHBVN for Ring/backup arrangement).
- (x) Supply, Erection, Testing & Commissioning of outdoor/indoor types LT/HT cable sealing ends/Termination Kits with necessary consumables.
- (xi) Supply, Erection, Testing & Commissioning of LT crimping type lugs and termination of LT cables with necessary consumables
- (xii) Installation/erection of all electrical equipments and cable terminations above maximum flood level/ water logging level.
- (xiii) Prepare shop drawings for above activities including foundation requirement and taking approval from DHBVN.
- (xiv) Supply, Installation, Testing, commissioning of H poles with accessories, Compact substations, LT/HT cables with terminations, Feeder pillars, cable trays with accessories, outdoor Ring Main Units, Isolator module sets and other electrical components require for successful operation of Electrical system, under supervision of DHBVN.
- (xv) Supply and Installation of Maintenance free Earthing system as per specifications provided. Earthing system shall be provided for H poles, compact substations, each Feeder pillars, Outdoor ring main units, Isolator module sets, light poles etc. Each item shall be earthed with at least two separate earthing connections.
- (xvi) Supply and Installation of chemical earthing system. This includes earthing rods, clamps, earthing strips.
- (xvii) Supply of underground cable fault detection unit to detect the fault from direct buried cable/cables running from pipe/cable tray.
- (xviii) Supply, Installation, Testing and commissioning of LED street lighting system with provision of remote communication including but not limited to dimming of LED lamps, Remote energy

monitoring, Astronomical timer, Manual override, Real time monitoring, web based interface etc. Achievable Lux level shall be as per Indian standard.

- (xix) Cabling and earthing of Landscape lighting system shall be performed by contractor
- (xx) Contractor Scope includes undergrounding of all LT/HT cables within RoW of the road. Continuity of existing LT supply shall be maintained in co-ordination with DHBVN.
- (xxi) Earthing of all light poles is in scope of contractor.
- (xxii) All Electrical work shall be performed under supervision of FSCL/DHBVN.
- (xxiii) Contractor has to arrange a secured place where he shall store procured material i.e. compact substations, Feeder pillars, outdoor RMU, Isolator module set, cables, cable trays with accessories, material require for direct cable buried system and other accessories required for project. Contractor shall be responsible for safe custody of these items as well as dismantled items till taken over by FSCL/DHBVN.
- (xxiv) The contractor shall ascertain the quantities of items such as HT/LT cables, earthing material, supporting steel pipes etc. and procure the material as per requirement. Excess material brought to site & not installed shall not be accepted by the DHBVN.
- (xxv) Contractor shall ensure about 'All Warrantee and Guarantee shall be on the name of DHBVN'.

The maintenance of the Power distribution System including other works executed by the contractor under support services period shall be comprehensive, as set forth herein, in nature and would broadly include but not be limited to diagnos.is and rectification faults/ instrument failures.

7.1.4.The scope for Operation and Maintenance work includes but not limited to following:

- (i) Operation and maintenance of the Power Distribution Network including all required components, equipment, accessories to be supplied/replaced. The scope of the contractor shall be to ensure smooth running of the system.
- (ii) Supply, construction, erection, installation, testing, commissioning and O&M work of the contractor for shall be done under supervision of DHBVN.
- (iii) Contractor shall handover the Electrical system to DHBVN by submitting the completion Certificate of the work.
- (iv) All the faults that occur on the proposed scope of works, shall be rectified/resolved immediately by the contractor under supervision of DHBVN at its (contractor's) own cost. The faults that are not on the scope of work shall be repaired by the DHBVN at its own cost.
- (v) In case of a fault on the Electrical system under scope of work, contractor shall immediately approach DHBVN to isolate the faulty section, safe guard and taking hand over the faulty section under a work permit in the name of DHBVN authorized engineer for the rectification under DHBVN supervision and in co-ordination with FSCL. Contractor shall rectify the fault on priority basis in co-ordination with DHBVN.
- (vi) The contractor will rectify the fault to the satisfaction of the DHBVN staff. Once approved by DHBVN, the contractor has to perform tests and commission the line in accordance with the DHBVN norms. All permits for rectifying the faults shall be as per DHBVN norms and practice.
- (vii) Contractor will be responsible for the faults as listed herewith but not limited to Material fault (Insulators, Lightning arresters, Gang operating switch, LT/HT Cables, Termination kits etc.), Equipment faults (LT/HT panels and switchgears, Transformers, outdoor RMU, Isolator modules and feeder pillars etc.), Loose electrical connections and Improper alignment.
- (viii) On completion of maintenance / rectification of fault on any of the equipment under Electrical scope of work, the contractor shall carry out the required tests along with DHBVN representative and then provide clearance for taking into service.

- (ix) DHBVN and FSCL will be the final authority to decide which agency is responsible for occurrence of the fault. Contractor will bound with the decision taken by DHBVN and FSCL.
- (x) Within the Defect Liability Period (DLP) of 2 years, the contractor is responsible for replacement of any damaged equipments any damaged equipment or its part/s due to the reasons not limited to any of the fault, inferior quality of material, bad workmanship etc. at his own cost with his own cost.
- (xi) The contractor is responsible for Maintenance and Repair/ replacement of defective equipment installed under the project. The contractor shall have close co-ordination with the equipment supplier.
- (xii) Predictive and preventive maintenance of the infrastructure as per Indian standard /DHBVN regulation.
- (xiii) In case, DHBVN decided to add any infrastructure during O&M period within defined Electrical scope of work, the contractor shall undertake such works. The cost of such works shall be paid by the DHBVN as per DHBVN SOR rates.
- (xiv) Updation of any type of software in devices not limited to Field Remote Terminal Unit (FTRU), communication modules etc.
- (xv) Services to bring up any or all power distribution systems upon its failure and to restore the functioning of the same etc.
- (xvi) Handling and redresses of consumer and local authorities complaints arising out of the downtime of the supply or any other related issue in connection with the infrastructure laid under the project and support services requirement and SLA.
- (xvii) Coordination with civic authorities on the matters of system being maintained by the contractor.
- (xviii) Contractor has to make its own arrangement to clear the Electrical ducts at all times from water or any foreign objects.
- (xix) During the execution of the infrastructure work it is expected that certain portion of the work shall be completed and put to service before the actual completion and commissioning of the entire project, then in that case also the support services including O&M shall be the responsibility of the contractor in accordance with this document at no additional/ extra cost towards payment of support services (O&M) during this intervening period.
- (xx) In case of a scenario during the O&M period when some equipment gets damaged by natural causes such as flood, earthquake, storm etc. or accidents by vehicles etc. which are beyond the scope of warranty, then in those cases the cost of the replacement of that equipment shall be borne by the DHBVN on the same rates as per the award of original project with the price variation applicable on DTs and cables. For other items the rates shall be governed by the consumer price index during the O&M period for which the consumer price index as on the date of award of the work shall be applicable by considering the percent change from the date of Completion of entire project to the date on which the equipment have been installed. The price for the whole O&M period will be given considering the increased percentage in consumer price index with respect to the last year.

7.1.5.SERVICE DELIVERY MANAGEMENT

The Contractor shall provide detailed description for service delivery management for the complete project including deliverables and project management methodology for approval by engineer in charge of the project.

7.1.6.SERVICE HOURS:

- (i) The Contractor's standard hours of service shall be 24 hours a day, 7 days a week throughout the year (i.e. 24X365).

- (ii) The Contractor shall be responsible for 24*7*365 management of all the systems as per scope of work with services rendered as per Service Level Agreement between utility & Contractor.

7.1.7.SERVICE PERSONNEL:-

The minimum person deployed by the contractor shall be as given below. However, contractor need to assess the resources requirement by himself that is necessary for complete the task in timely manner.

- (i) One no. Sr. Engineer having minimum qualification as Graduate engineer in electrical engineering with at least fifteen (15) years experience in the similar work for the entire project area who will provide monitoring and solutions to any issue or fault and has the responsibility for managing the complete service delivery during the contractual arrangement between department and end user. Senior Engineer will be responsible for preparation and delivery of all monthly/weekly/daily reports as well as all invoicing relating to the service being delivered. The monthly/ weekly/ daily report formats will be approved by Engineer in charge and can also be changed as per the requirement of DHBVN.
- (ii) 2 nos. Engineers with Diploma in Electrical engineering having at least five (5) years experience in the similar work.
- (iii) 4 nos. technical personnel in ITI electrical with at least two (2) years experience in the similar work.

The support personnel except the Senior Engineer shall be deployed to be available 24X7. The number of personnel shall be enhanced as per the requirement to the satisfaction of DHBVN. It is the intent that the downtime shall be negligible and therefore it is the responsibility to ensure that the faults/ failures are attended immediately.

7.1.8.OFFICE, STORES, SPARES and T&P:

Apart from the personnel deputed in the control room for system operation, the contractor will set up his own offices for the field staff deputed as well as his clerical staff at no extra cost. The contractor shall maintain a minimum spares installed under the project and along with tools and plants and machinery required for the scope under the SLA as per the final installed and commissioned quantity of the project area. The contractor shall maintain a minimum 2% inventory of quantity of all the necessary equipment, except DT, RMU, LT feeder panel, Isolator modules, all type of cables. The contractor shall maintain a minimum 0.5% inventory of each type/capacity of DT, RMU and LT feeder panel, Isolator modules and all type of cables (for the size LT XLPE cable of 3.5 CX300 sq.mm. will maintain 1%). He will also maintain the inventory asset register and the same will be submitted on monthly basis to the concerned XEN/Operation with copy to Engineer in charge and SE/Operation and also submit the annual audit report. The contractor will also provide at least 2 nos. mobile DT stations along with other material/ arrangement to restore the supply immediately in case of any fault. The security of the office/ store and the equipment shall be the contractor's responsibility.

7.1.9.SUPPORT PERIOD AND AMC:-

The O&M period shall be for five (5) years duration and shall commence just after the completion of all installation & commissioning jobs by the Contractor under the project and acceptance by the utility for the entire project, as well as during the period of execution of the project, as mentioned in the scope above.

7.1.10. MONITORING AND REPORTING:

The overall responsibility of smooth and continuous running of the system infrastructure installed under the project shall be with the contractor only. He shall have systematic monitoring mechanism in a place in order to ensure 24X7 operation. Contractor shall responsible for activity mention below:

- (i) Regularly monitor and maintain a log of the performance monitoring of the system signed by FSCL/DHBVN.
- (ii) Regular analysis of events and failure/ system interruption logs generated in the control room shall be carried out and the report be submitted.
- (iii) To undertake actions in accordance with the results of the log analysis to ensure that the hindrances in the infrastructure are identified and remedial action is taken.
- (iv) Submit report to the Engineer in charge on a weekly basis about the system running condition, Interruption occurs for which he shall get the MIS formats approved from the Engineer in charge.
- (v) Submit report on a monthly basis detailing about the disruptions and other issues encountered during the month.
- (vi) The format for the monthly report shall also be got approved by the Engineer in Charge. In general the MIS report shall depict the No. of Disruptions, redressal, analysis etc. and the monthly report shall include details of each disturbance, time, duration of downtime, nature of problem, time of restoration of supply, duration, issues, suggestions etc.

7.1.11. STANDARD TIME LIMIT OF POWER SUPPLY RESTORATION

Penalty: Notwithstanding to the penalty indicated in the clause no. 45 of GCC (General condition of contract) and any other clauses for the delay in O & M, the penalties for non-compliance of O&M of Electrical items only will be levied as per below table.

Sr. No.	Nature of service	Standard (indicating Maximum time limit for restoration of supply for rendering services)		Penalty Amount	
		Through Alternative source/Ring main	Supply restoration from original source	Through Alternative source/Ring main	Supply restoration from original source
1	Normal fuse off/ ACB/MCCB Tripping	Within 30 mins	Within 4 hrs	Rs. 100 in each case of default	Rs. 100 in each case of default
2	HT Breakdowns/Cable Damage	Within 15 mins	Within 12 hrs	Rs. 1000 in each case of default	Rs. 1000 in each case of default
3	LT Line Breakdowns/Cable Damage	Within 1 hrs	Within 12 hrs	Rs. 1000 in each case of default	Rs. 1000 in each case of default
4	Distribution Transformer Failure	Within 1 hrs	Within 6 hrs	Rs. 1000 in each case of default	Rs. 1000 in each case of default
5	RMU failure	Within 1 hrs	Within 6 hrs	Rs. 1000 in each case of default	Rs. 1000 in each case of default
6	LT panel/ feeder Pillar failure	Within 1 hrs	Within 6 hrs	Rs. 1000 in each case of default	Rs. 1000 in each case of default

Note: Above mention time limit is standard however it may vary based on type of fault or break down. Time limit can be increased case to case subject to prior approval of Engineer In charge.

7.1.12. PREVENTIVE MAINTENANCE

The Contractor shall undertake preventive maintenance of all equipment supplied and installed under the scope of the project. The contractor will schedule the maintenance of equipment and get the schedule

approved in advance from the FSCL/DHBVN concerned. In case of failure to obtain prior approval before maintenance then penalty charges shall be applicable. The Contractor will prepare the report of maintenance performed and submit the same to the Engineer-in-charge weekly for approval.

7.1.13. HANDING OVER/ TAKING OVER:

After the successful completion of the O&M period, all the installed assets maintained by the contractor as well as the inventory as per the minimum fixed and applicable on the last day of O&M services and tools and plants etc. shall be handed over to the DHBVN without any cost.

7.1.14. CONTRACTOR'S RESPONSIBILITY:

- (i) To ensure smooth and 24X7 availability of quality power supply to the consumers in accordance with the above.
- (ii) Adherence to the prevailing statutes/ guidelines etc. pertaining to the above.
- (iii) Deploy qualified and experienced personnel for providing services under the agreement.
- (iv) Coordination with Concern authorities on various issues.
- (v) To ensure that all the existing laws are adhered.
- (vi) Maintain close and harmonious coordination with the DHBVN's office, field staff and all other stakeholders.

7.1.15. EMPLOYER'S RESPONSIBILITY:

- (i) To provide requisite support to the contractor in terms of line shutdowns etc.
- (ii) To maintain close and harmonious coordination with the contractor's office and field staff.

8.1. TECHNICAL SPECIFICATIONS FOR ROAD GENERAL (MORTH 5th Revised-Section-100)

8.2. Introduction

These specifications shall apply to all such road and bridge works as are required to be executed under the Contract or otherwise directed by the Engineer-in-Charge (hereinafter referred to as the Engineer). In every case, the work shall be carried out to the satisfaction of the Engineer and conform to the location, lines, dimensions, grades and cross-sections shown on the drawings or as decided by the Engineer. The quality of materials, processing of materials as may be needed at the site, salient features of the construction work and quality of finished work, measures for safety of workers and public and traffic arrangements during execution shall comply with the requirements set forth in succeeding sections. Where the drawings and Specifications describe a portion of the work only in general terms, and not in complete detail, it shall be understood that only the sound engineering practice is to prevail, materials and workmanship of the best quality are to be employed and the instructions of the Engineer are to be fully complied with.

A list of Indian Roads Congress (IRC) Specifications and recommended Codes of Practice which have been referred in these Specifications is given at Appendix-1. The latest edition of all Specifications/Standards/Codes of IRC till 60 (sixty) days before the final date of submission of the tender, shall be adopted. In case of any conflict or inconsistency in the provisions of the applicable Specifications/Standards/Codes of IRC, provisions contained in these Specifications shall apply.

8.3. Definitions

The words like Contract, Contractor, Engineer (synonymous with Engineer-in-charge), Drawings, Employer, Government, Works and Work Site used in these Specifications shall be considered to have the meaning as understood from the definitions of these terms given in the General Conditions of Contract.

8.4. Material and Test Standards

The relevant standards for materials, as well as the testing procedures, have been indicated at appropriate places in the specifications. A list of these standards with their full title are included at Appendix-2 (PI referred Morth 5th Revision).

8.5. Sieve Standards

The sieve designations referred to in the Specifications correspond to those specified by Bureau of Indian Standards in IS: 460. Table 100-1(PI referred Morth 5th Revision) gives the list of the commonly used IS sieves.

8.6. Scope of Work

8.6.1. The work to be carried out under the Contract shall consist of the various items as generally described in the Contract Documents as well as in the Bill of Quantities furnished in the Contract Documents.

8.6.2. Conformity with Drawings/Allowable Deviations

8.6.2.1. All works performed and all materials furnished shall be in conformity with the lines, grades, typical sections, dimensions, material requirements, and tolerances shown in the drawings or as indicated in the Specifications.

8.6.2.2. The works to be performed shall also include all general works preparatory to the construction

of roads. Bridges, structures, canal crossings, drainage and all other related works. The works shall include work of any kind necessary for the due and satisfactory construction, Completion and maintenance of works to the intent and meaning of the drawings and these Specifications and further drawings and orders that may be issued by the Engineer from time to time. The scope of work shall include compliance by the Contractor with all Conditions of Contract, whether specifically mentioned or not in the various Sections of these Specifications, all materials, apparatus, plant, equipment, tools, fuel, water, strutting, timbering, transport, offices, stores, workshop, staff, labour and the provision of proper and sufficient protective works, diversions, temporary fencing and lighting. It shall include all works related to safety of road user. It shall also include safety of workers at construction site, first aid equipment, suitable accommodation for the staff and workmen with adequate sanitary arrangements, the effecting and maintenance of all insurances, the payment of all wages, salaries, fees, royalties, duties or other charges arising out of the erection of works and the regular clearance of rubbish, reinstatement and clearing-up of the site as may be required on completion of works, safety of the public and protection of the works and adjoining land/ structures.

8.6.2.3. The Contractor shall ensure that all actions are taken to build in quality assurance (QA) in the planning, management and execution of works. The quality assurance shall cover all stages of work such as setting out, selection of materials, selection of construction methods, selection of equipment and plant, deployment of personnel and supervisory staff, quality control testing, etc. The QA programme shall cover the details as per IRC: SP: 47 and IRC: SP: 57. These shall broadly cover quality assurance aspects of all services rendered, all items to be supplied and all activities to be performed under the contract including temporary structures and equipment which will influence the quality of the completed works or the progress of the contract. As a minimum, it shall cover the following:

- i) Organization and management responsibility,
- ii) Document and data control,
- iii) Construction programme,
- iv) Method statement,
- v) Process control,
- vi) Working, inspection, testing and documentary procedures,
- vii) Arrangement for smooth and safe traffic flow during construction and maintenance,
- viii) Control and documentation of purchasing and handling of materials,
- ix) Maintenance of records for non-conformity and timely corrective actions,
- x) Internal quality audit,
- xi) Training of staff,
- xii) Environment Management Plan (EMP).

8.6.2.4. The QA plan shall be submitted to the Engineer for approval, not later than 28 days from the date of signing of the contract agreement. The work of building in quality assurance shall be deemed to be covered in the scope of the work.

8.6.2.5. The Contractor shall furnish, at least 7 days in advance, unless otherwise stipulated in the contract, his programme of commencement of each item of work, including the method statement including deployment of plant and equipment for the works included in the contract and any other work for which the Engineer may demand the method statement. He shall provide all information to the satisfaction of the Engineer to ensure its adequacy. The sole responsibility for the safety and

adequacy of the methods adopted by the Contractor will, however, rest on the Contractor, irrespective of any approval given by the Engineer.

8.7. Inspection of Materials before Incorporation

8.7.1.1. All materials shall be inspected, tested and accepted by the Engineer as per these specifications, before incorporation in the work. The frequencies and methods of sampling and testing materials, including those required for definite purpose and not covered by these specifications shall be in accordance to the relevant IRC or BIS or AASHTO/ASTMI BS Standards in order of priority.

8.7.1.2. All materials or work not conforming to the requirements of the Specifications shall be considered unacceptable and rejected. The unacceptable materials or work that are rejected shall be immediately removed unless the defects are corrected and approved by the Engineer. If the Contractor fails to comply promptly with any order of the Engineer made under the provisions of this Clause, the Engineer has the authority to remove and replace unacceptable materials or work and to deduct from money due to the Contractor the cost of removal and replacement.

8.8. Inspection of Material at Source

The Engineer may choose to inspect material at source. In the event, the following conditions shall be met.

- a) The Contractor and the manufacturer of material shall assist and co-operate with the Engineer in carrying out the inspection.
- b) The Engineer shall have right to enter areas of plant where the manufacture or production of material is carried out.

8.9. Delivery, Storage and Handling of Materials

8.9.1. All materials shall be handled and stored in appropriate manner to preserve their quality and fitness for the work. During the handling of all aggregates or other construction materials, special care shall be taken to prevent contamination. Furthermore, aggregate shall be handled in such a manner as to prevent segregation.

8.9.2. Vehicles used in transporting construction material shall be kept clean and in proper working condition so as to prevent the loss of materials during transportation and meet the requirements of the Specifications.

8.9.3. The Contractor may be allowed to store materials and equipment within the right-of-way at location approved by the Engineer, but shall be responsible for the restoration and repair of any damage to plantation, signs, property or any assets resulting from such operations. Any additional space that may be needed for storage purposes and for placing of plant and equipment shall be provided by the Contractor at no additional cost to the Employer.

8.10. Materials Furnished by the Employer

When the Contract provides that certain materials required to complete the work will be supplied by the Employer, such material will be delivered or made available to the Contractor at the location(s) specified in the Contract. The Contractor shall be responsible for all damages occurring to the materials furnished by the Employer while the materials are in his possession. Any demurrage or storage charges shall also be the responsibility of the Contractor. The Contractor shall include the cost of handling, transportation and placing all Employer furnished materials in the Contract unit price for the relevant pay item.

8.11. Law to be observed

The Contractor shall observe and comply with all Central and State laws, local laws and ordinance which affect those employed on the work or affect the conduct of the work. The Contractor shall provide all safeguards, safety devices, and protective equipment and take any other actions necessary for safety and health of employees on the project.

8.12. Patented Devices, Materials and Processes

If the Contractor is required or desires with the approval of the Engineer to use any design, device, material or process covered by trademark, patent or copyright, the Contractor shall obtain the right for its use by legal agreement with the patentee or owner. A copy of the agreement shall be furnished to the Engineer. Contract prices shall include all royalties and costs arising from patents, trademarks and copyrights.

8.13. Construction equipment

In addition to the conditions indicated in the Contract Documents, the following conditions regarding use of equipment in works shall be satisfied:

- (a) The Contractor shall be required to give a trial run of the equipment for establishing their capability to achieve the laid down Specifications and tolerances to the satisfaction of the Engineer before commencement of the work;
- (b) All equipment provided shall be of proven efficiency and shall be operated and maintained at all times in a manner acceptable to the Engineer;
- (c) Plants, equipment and instruments provided shall have adequate sensitivity, facility for calibration to desired level and shall be robust;
- (d) Plant, equipment and instrument provided shall have data logging arrangement and control systems to enable automatic feedback control of process;
- (e) Plants, equipment and instruments provided shall have adequate safety features and pollution control devices;
- (f) Plant, equipment and instruments provided shall be operated by skilled and qualified operators;
- (g) All the plant/equipment to be deployed on the works shall be got approved from the Engineer for ensuring their fitness and efficiency before commencement of work;
- (h) Any material or equipment not meeting the approval of the Engineer shall be removed from the site forthwith;
- (i) No equipment shall be removed from site without permission of the Engineer;
- (j) The Contractor shall also make available stand by equipment and spare parts; and
- (k) The Contractor shall also make available equipment for site quality control work as directed by the Engineer.

8.14. Drawing

The drawings provided in the Tender Documents shall be used as reference only. The Contractor shall study the nature and type of work and ensure that the rate and prices quoted by him in the Bill of Quantities have due consideration of the site and complexities of work involved during actual execution/construction.

The Contractor based on his surveys and investigations, shall submit the working drawings (hard and soft copy) to the Engineer for each activity at least 45 days in advance of the scheduled date to the start of the activity as per his approved work programme. The working drawings shall clearly show the modifications, if any, proposed with reference to corresponding tender drawings. The Engineer shall review the working drawings including the modifications proposed, if any, revise the drawings, if required, approve and issue to the Contractor two copies of Good for Construction (GFC) drawings at least 28 days in advance of the

scheduled date of the start of the activity.

Examination and/or approval by the Engineer of any drawings or other documents submitted by the Contractor shall not relieve the Contractor of his responsibilities or liabilities under the Contract. The tendered rates/prices for the work shall be deemed to include the cost of Preparation, supply and delivery of all necessary drawings, prints, tracings and negatives which the Contractor is required to provide in accordance with the Contract.

8.15. Site information

The information about the site of work and site conditions in the Tender Documents is given in good faith for guidance only but it shall be the responsibility of the Contractor to satisfy himself regarding all aspects of site conditions. The information about the site of work and site conditions in the Tender Documents is given in good faith for guidance only but it shall be the responsibility of the Contractor to satisfy himself regarding all aspects of site conditions. Whereas the right-of-way to the bridge sites/road works shall be provided to the Contractor by the Employer, the Contractor shall have to make his own arrangement for the land required by him for site offices, field laboratory, site for plants and equipment, maintenance and repair workshop, construction workers' camp, stores etc.

8.16. Setting Out

The Contractor shall establish working bench marks tied with the Reference bench mark in the area soon after taking possession of the site. The Reference bench mark for the area shall be as indicated in the Contract Documents and the values of the same shall be obtained by the Contractor from the Engineer. The working bench marks shall be at the rate of four per km and also at or near all drainage structures, over-bridges and underpasses. The working bench marks /levels should be got approved from the Engineer. Checks must be made on these bench marks once every month and adjustments, if any, got approved from the Engineer and recorded. An up-to-date record of all bench marks including approved adjustments, if any, shall be maintained by the Contractor and also a copy supplied to the Engineer for his record.

The lines and levels of formation, side slopes, drainage works, carriageways and shoulders shall be carefully set out and frequently checked, care being taken to ensure that correct gradients and cross-sections are obtained everywhere. In order to facilitate the setting out of the works, the center line of the carriageway or highway must be accurately established by the Contractor and approved by the Engineer. It must then be accurately referenced in a manner satisfactory to the Engineer, at every 50 m intervals in plain and rolling terrains and 20 m intervals in hilly terrain and in all curve points as directed by the Engineer, with marker pegs and chainage boards set in or near the fence line, and a schedule of reference dimensions shall be prepared and supplied by the Contractor to the Engineer. These markers shall be maintained until the works reach finished formation level and are accepted by the Engineer. On construction reaching the formation level stage, the center line shall again be set out by the Contractor and when approved by the Engineer, shall be accurately referenced in a manner satisfactory to the Engineer by marker pegs set at the outer limits of the formation. No reference peg or marker shall be moved or withdrawn without the approval of the Engineer and no earthwork or structural work shall commence until the center line has been referenced. The Contractor will be the sole responsible party for safe-guarding all survey monuments, bench marks, beacons, etc. The Engineer will provide the Contractor with the data necessary for setting out the center line. The Contractor on the site shall verify all dimensions and levels shown on the drawings or mentioned in documents forming part of or issued under the Contract and he shall immediately inform the Engineer of any apparent errors or discrepancies in such dimensions and levels. The Contractor shall, in connection with the staking out of the center line, survey the terrain along the road and shall submit to the Engineer for his approval, a profile along the road center line and cross-sections at intervals as required

by the Engineer. The construction staking shall be done by personnel who are trained and experienced in construction layout and staking of the type and kind required in the Contract. Field notes shall be kept in standard, bound field notebooks as approved by the Engineer. Field notes shall be subject to inspection by the Engineer and shall be the property of the Employer.

The Contractor shall correct any deficient staking or construction work which resulted from inaccuracies in the staking operations or from the Contractor's failure to report inaccuracies in the plans or survey data furnished by the Department. After obtaining approval of the Engineer, work on earthwork can commence. The profile and cross-sections as per Section 305, shall form the basis for measurements and payment. The Contractor shall be responsible for ensuring that all the basic traverse points are in place at the commencement of the contract and, if any, are missing, or appear to have been disturbed, the Contractor shall make arrangements to re-establish these points. A "survey File" containing the necessary data will be made available for this purpose. If in the opinion of the Engineer, design modifications of the centre line or grade are advisable, the Engineer will issue detailed instructions to the Contractor and the Contractor shall perform the modifications in the field, as required, and modify the ground levels on the cross-sections accordingly as many times as required. There will be no separate payment for any survey work performed by the Contractor. The cost of these services shall be considered as being included in the rate of the items of work in the Bill of Quantities. Precision automatic levels, having a standard deviation of ± 2 mm per km, and fitted with micrometer attachment shall be used for all double run levelling work. Setting out of the road alignment and measurement of angles shall be done by using Total Station with traversing target, having an accuracy of one second. Measurement of distances shall be done preferably using precision instruments like Diatomite. The work of setting out shall be deemed to be a part of general works preparatory to the execution of work and no separate payment shall be made for the same.

8.17. Public utilities

Drawings scheduling the affected services like water pipes, sewers, oil pipelines, cables, gas ducts etc. owned by various authorities including Public Undertakings and Local Authorities included in the Contract Documents shall be verified by the Contractor for the accuracy of the information prior to the commencement of any work. The Contractor shall notify all utility agencies who may have installation in the work area and secure their assistance in locating and identifying all utilities before starting any work that may cause any damage to such utilities.

The Contractor shall schedule work in such a manner as to protect existing utility facilities until they are relocated, abandoned or replaced. The Contractor shall ensure that all utilities encountered within the Right of Way i.e. OFC Cable, telephone, power, water supply, sewerage or any others, remain operational at all times. Any utility, if damaged, due to construction operation, shall be promptly repaired by the Contractor at his cost. Notwithstanding the fact that the information on affected services may not be exhaustive, the final position of these services within the works shall be supposed to have been indicated based on the information furnished by different bodies and to the extent the bodies are familiar with the final proposals. The intermediate stages of the works are, however, unknown at the design stage, these being dictated by the Contractor's methods of working. Accordingly, the Contractor's programme must take into account the period of notice and duration of diversionary works of each body as given on the Drawings and the Contractor must also allow for any effect of these services and alterations upon the Works and for arranging regular meetings with the various bodies at the commencement of the Contract and throughout the period of the Works, the Contractor shall have no objection if the public utility bodies vary their decisions in the execution of their proposals in terms of programme and construction, provided that, in the opinion of the Engineer, the Contractor has received reasonable notice thereof before the relevant alterations are put in hand. No removal of or alterations to the utility shall be carried out unless written instructions are issued by the Engineer. The Contractor who must also take all measures reasonably required by the various bodies

to protect their services and property during the progress of the Works must temporarily support any services affected by the Works. The Contractor may be required to carry out certain works for and on behalf of various bodies, which he shall provide, with the prior approval of the Engineer. The work of temporarily supporting and protecting the public utility services during execution of the Works shall be deemed to be part of the Contract and no extra payment shall be made for the same. The Contractor shall be responsible to co-ordinate with the service providers for cutting of trees, shifting of utilities, removal of encroachments etc. to make site unencumbered for completion of work. This will include frequent follow-up meetings. Coordination for making project site unencumbered shall be deemed to be part of the Contract and no extra payment shall be made for the same. In some cases, the Contractor may be required to carry out the removal or shifting of certain services/utilities on specific orders from the Engineer for which payment shall be made to him. The Contractor, however, shall take up such works, only after obtaining clearance from the Engineer and ensuring adequate safety measures.

8.18. Precautions for safeguarding the environment

8.18.1. General

The Contractor shall take all precautions for safeguarding the environment during the course of the construction of the works. He shall abide by all laws, rules and regulations in force governing pollution and environmental protection that are applicable in the area where the works are situated.

8.18.2. Borrow Pits for Embankment Construction

Borrow pits shall be selected only after testing the suitability of materials for use in construction and shall not normally be dug in the right-of-way of the road. The stipulations in Section 305.2.2 shall govern. The borrow pits shall not be left in a condition likely to cause hazard to human and animal life. The Contractor shall seek prior approval from the concerned authorities for operating the borrow pits.

8.18.3. Quarry Operations

The Contractor shall obtain materials from quarries only after obtaining the consent of the Mining Department or other concerned authorities. The quarry operations shall be undertaken within the purview of the rules and regulations in force.

8.18.4. Control of Soil Erosion, Sedimentation and Water Pollution

The Contractor shall carry out the works in such a manner that soil erosion is fully controlled, and sedimentation and pollution of natural water courses, ponds, tanks and reservoirs is avoided. The stipulations in Clause 306 shall govern.

8.18.5. Pollution from Plants and Batching Plants

Stone crushing and screening plants, bituminous hot-mix plants, concrete batching plants etc. shall be located sufficiently away from habitation, agricultural operations or industrial establishments. The locations shall be as permissible under the laws governed by local bodies' administration of the area. The Contractor shall take every precaution to reduce the levels of noise, vibration, dust and emissions from his plants and shall be fully responsible for any claims or damages caused to the owners of property, fields and residences in the vicinity and violation of pollution control norms, if any.

8.18.6. Substances Hazardous to Health

The Contractor shall not use or generate any materials in the works which are hazardous to the health of persons, animals or vegetation. Where it is necessary to use some substances which can cause injury to the

health of workers, the Contractor shall provide protective clothing or appliances to his workers

8.18.7. Use of Nuclear Gauges

Nuclear gauges shall be used only where permitted by the Engineer. The Contractor shall provide the Engineer with a copy of the regulations governing the safe use of nuclear gauges he intends to employ and shall abide by such regulations.

8.18.8. Environmental Protection

The Contractor must take all reasonable steps to minimize dust nuisance during the construction of the works along the haul roads and the worksites by sprinkling water at a frequency specified by the Engineer. All existing highways and roads used by vehicles or equipment's of the Contractor or any of his sub-contractors or suppliers of materials or plant, and similarly any new roads which are part of the works and which are being used by traffic, shall be kept clean and clear of all dust mud or other extraneous materials dropped by the said vehicles. Similarly, all dust mud or other extraneous materials from the works spreading on these highways shall be immediately cleared by the Contractor. Clearance shall be effected immediately by sweeping and removal of debris, and all dust, mud and other debris shall be removed entirely from the road surface. Additionally, if so directed by the Engineer, the road surface shall be hosed or watered using suitable equipment. Damages to existing road: Any structural damage and loss of riding surface caused to the existing roads by the Contractor's construction vehicles Equipment shall be made good without any extra cost. Compliance with the foregoing will not relieve the Contractor of any responsibility for complying with the requirements of any authority in respect of the roads used by him.

8.18.9. Air Quality

The Contractor shall device and implements methods of working to minimize dust, gaseous and other air-borne emissions and carry out the Works in such a manner as to minimize adverse impacts on the air quality. The Contractor shall utilize effective water sprays during delivery, manufacture, processing and handling of materials when dust is likely to be created, and to dampen stored materials during dry and windy weather. Stockpiles of friable materials shall be covered with clean tarpaulins, with applications of sprayed water during dry and windy weather. Stockpiles of materials or debris shall be dampened prior to their movement, except where this is contrary to the Specification. Any vehicle with open load-carrying area used for transporting potentially dust-producing material shall have properly fitting side and tail boards. Materials having the potential to produce dust shall not be loaded to a level higher than the side and tail boards and shall be covered with clean tarpaulins in good condition. The tarpaulin shall be properly secured and extend at least 300 mm over the edges of the side and tail boards.

8.18.10. Water Sources and Water Quality

The Contractor shall provide independent sources of water supply, such as bore wells, for use in the Works and for associated storage, workshop and work force compounds. Prior approval shall be obtained from the relevant State Authorities and all installations shall be in compliance with local regulations. The Contractor shall protect all watercourses, waterways, ditches, canals, drains, lakes, reservoirs and the like from pollution as a result of the execution of the Works. All water and other liquid waste products like petroleum products and chemicals arising on the Site shall be collected and disposed of at a location on or off the Site and in a manner that shall not cause either nuisance or pollution. The Contractor shall at all times ensure that all existing stream courses and drains within and adjacent to the Site are kept safe and free from any debris and any materials arising from the Works. The Contractor shall not discharge or deposit any matter arising from the execution of the Works into any water course except with the permission of the Engineer and the regulatory authority concerned.

8.18.11.Occupational Health and Safety of the Workforce

The Contractor shall prepare and submit to the Engineer the Occupational Health & Safety

Procedures/Practices for the workforce in all quarry sites, plant sites, work sites, camp sites, etc., in accordance with the applicable laws.

8.18.12.Control and Disposal of Wastes

The Contractor shall control the disposal of all forms of waste generated by the construction operations and in all associated activities. No uncontrolled deposition or dumping shall be permitted. Wastes to be so controlled shall include, but shall not be limited to, all forms of fuels and engine oils, all types of bitumen, cement, surplus aggregates, gravels, bituminous mixtures etc. The Contractor shall make specific provision for the proper disposal of these and any other waste products, conforming to local regulations and acceptable to the Engineer.

8.18.13.Transport of Hazardous Materials

Transport of hazardous materials, in bulk or in sealed containers, shall meet the requirements of the State regulations. Prior to ordering transport of hazardous material in bulk, the Contractor must obtain the approval of the relevant authority as well as of the Engineer. Safety laws of the local authorities shall govern the transport of diesel, petrol, gaseous material, chemical and explosives for quarrying. Precautionary measures and conformity with regulations shall be stated in a Method Statement for the approval of the Engineer. Sealed containers of hazardous materials shall be stored in a well-ventilated room, well guarded and secured.

8.18.14.Emergency Response

The Contractor shall plan and provide remedial measures to be implemented in the event of occurrence of emergencies such as spillages of oil or bitumen or chemicals, fire. The Contractor shall provide the Engineer with a statement of the measures he intends to implement in the event of such an emergency, which shall include a statement of how he intends to provide personnel adequately trained to implement such measures.

8.18.15.Measurement for Payment

The compliance of all provisions made in this Clause 1.16 shall be deemed to be incidental to the work and no separate measurement or payment shall be made. The Contractor shall be deemed to have made allowance for all such compliance with these provisions in the preparation of his bid for items of work included in the Bill of Quantities and full compensation for such compliance shall be deemed to be covered by the bid price.

8.19. Arrangement for traffic during construction

8.19.1. General

The Contractor shall at all times, carry out work on the highway in a manner creating least interference to the flow of traffic while consistent with the satisfactory execution of the same. For all works involving improvements to the existing highway, the Contractor shall, in accordance with the directives of the Engineer, provide and maintain, during execution of the work, a passage for traffic either along a part of the existing carriageway under improvement or along a temporary diversion constructed close to the highway. Before taking up any construction or maintenance operation, the Contractor shall prepare a Traffic Management Plan for each work zone and submit it to the Engineer for prior approval. This plan

should include inter alia:

- (i) Provision of a qualified safety officer with support staff to serve as a site safety team
- (ii) Provision of traffic safety devices and road signs in construction zones as per IRC: SP: 55 and other relevant IRC Codes and para 112.4:
- (iii) Safety measures for the workers engaged including personal protection equipment
- (iv) First aid and emergency response arrangements
- (v) Details and drawings of arrangements in compliance with other sub Sections of this Section.

8.19.2. Passage of Traffic along a Part of the Existing Carriageway under Improvement For Widening/strengthening existing carriageway where part width of the existing carriageway is proposed to be used for passage of traffic, treated shoulders shall be provided on the side on which work is not in progress. The treatment to the shoulder shall consist of providing at least 150 mm thick granular (Wet Mix Macadam/Water Bound Macadam) base course covered with bituminous surface dressing in a width of at least 1.5 m and the treated shoulder shall be maintained throughout the period during which traffic uses the same to the satisfaction of the Engineer. The continuous length, in which such work shall be carried out, would be limited normally to 500 m at a place. However, where the Engineer in longer stretches passing places at least 20 m long with additional paved width of 2.5 m shall be provided at every 0.5 km interval allows work. In case of eccentric widening of existing two-lane to four-lane, the additional two-lanes would be constructed first and the traffic diverted to it and only thereafter the required treatment to the existing carriageway would be carried out. In case of concentric widening, stipulations as in paragraph above shall apply. After the works are completed, with the approval of the Engineer, the treated shoulder shall be dismantled, the debris disposed of and the area cleared as per the direction of the Engineer.

8.19.3. Passage of Traffic along a Temporary Diversion

In stretches where it is not possible to pass the traffic on part width of the carriageway, a temporary diversion shall be constructed with 7 m carriageway and 2.5 m earthen shoulders on each side with the following provision for road crust in the 7 m width:

- (i) Earthwork
- (ii) 200 mm (compacted) granular sub-base
- (iii) 225 mm (compacted) granular base course
- (iv) Priming and Tack Coat and
- (v) Premix carpet with Seal Coat/Mix Seal Surfacing

The location of such stretch, alignment and longitudinal section of diversion including junctions and temporary cross drainage provision shall be as approved by the Engineer.

8.19.4. Traffic Safety and Control

The Contractor shall take all necessary measures for the safety of traffic during construction and provide, erect and maintain such barricades, including signs, marking, flags, lights and flagmen as per the traffic management plan submitted by the Contractor and approved by the Engineer, referred to in Sub-Section 112.1. Before taking up any construction, an agreed phased programme for the diversion of traffic on the highway shall be drawn up in consultation with the Engineer. All construction equipment working or parked on or within the traffic lanes or shoulders under "Traffic maintained" conditions shall be equipped with flashing yellow beacons. The Contractor shall conduct all operations to minimize any drop-offs (abrupt changes in roadway) exposed to traffic. Drop-offs in the travelled way shall be protected by a

wedge of compacted stable material capable of carrying traffic (the wedge being 1 vertical to 4 horizontal or flatter).

The Engineer shall authorize other methods, to protect drop-offs when conditions do not allow a wedge of compacted, stable material. Warning signs, barricades, warning lights, and all other traffic control devices shall not be removed if the hazard has not been eliminated. Only upon receipt of specific written authorization from the Engineer, the Contractor may remove or cease to maintain warning signs, barricades, warning lights, and all other traffic control devices. The barricades erected on either side of the carriageway/portion of the carriageway closed to traffic, shall be of strong design to resist violation, and painted with alternate black and white stripes. Red lanterns or warning lights of similar type shall be mounted on the barricades at night and kept lit throughout from sunset to sunrise.

At the points where traffic is to deviate from its normal path (whether on temporary diversion or part width of the carriageway) the channel for traffic shall be clearly marked with the aid of pavement markings, painted drums or a similar device to the directions of the Engineer. At night, the passage shall be delineated with lanterns or other suitable light source including solar energy bulbs. One-way traffic operation shall be established whenever the traffic is to be passed over part of the carriageway inadequate for two-lane traffic. This shall be done with the help of temporary traffic signals or flagmen kept positioned on opposite sides during all hours. For regulation of traffic, the flagmen shall be equipped with red and green flags and lanterns/lights. On both sides, suitable regulatory/warning signs as approved by the Engineer shall be installed for the guidance of road users. On each approach, at least two signs shall be put up, one close to the point where transition of carriageway begins and the other 120 m away. The signs shall be of approved design and of reflective type, as directed by the Engineer.

8.19.5. Maintenance of Diversions and Traffic Control Devices

Signs, lights, barriers and other traffic control devices, adequate lighting and other arrangements, as well as the riding surface of diversions and treated shoulders shall be maintained in a satisfactory condition till such time they are required and as directed by the Engineer. The temporary travelled way shall be kept free of dust by frequent applications of water, if necessary.

8.19.6. Measurements for Payment and Rate

All arrangements, as contained in this Section 117 for safety of road users, during construction including provision of temporary diversions/temporary cross drainage structures/treated shoulders shall be measured and paid as per the BOQ. However their maintenance, dismantling and clearing debris shall be considered as incidental to the Works and shall not be paid separately

8.20. General rules for the measurement of works for payment

8.20.1. General

All measurements shall be made in the metric system. Different items of work shall be measured in accordance with the procedures set forth in the relevant Sections read in conjunction with the General Conditions of Contract. The same shall not, however, apply in the case of lump sum contracts. All measurements and computations, unless otherwise indicated, shall be carried nearest to limits (PI referred Morth 5th revision section 100). In recording dimensions of work, the sequence of length, width and height or depth or thickness shall be followed.

8.20.2. Measurement of Lead for Materials

Where lead is specified in the Contract for construction materials, the same shall be measured as described

hereunder: Lead shall be measured over the shortest practicable route and not the one actually taken and the decision of the Engineer in this regard shall be taken as final. Distances up to and including 100 m shall be measured in units of 50 m, exceeding 100 m but not exceeding 1 km in units of 100 m and exceeding 1 km in units of 500 m, the half and greater than half of the unit shall be reckoned as one as and less than half of the unit ignored. In this regard, the source of the material shall be divided into suitable blocks and for each block, the distance from the center of placing pertaining to that block shall be taken as the lead distance.

8.20.3. Measurement of Pavement Thickness for Payment on Volume Basis

The finished thickness of sub-bases, base and bituminous layers and concrete courses to be paid on volume basis shall be computed in the following manner:

Levels shall be taken before and after construction, at the grid of points 10m centre-to-centre longitudinally in straight reaches and 5 m centre-to-centre at curves. Normally, on two-lane roads, the levels shall be taken at four positions transversely, at 0.75 m and 2.75 m from either edge of the carriageway and on single-lane roads, these shall be taken at two positions transversely, being at 1.25 m from either edge of the carriageway. For multi-lane roads, levels shall be taken at two positions transversely for each lane. The transverse position for levels shall be 0.75 m from either edge of the carriageway and the remaining locations shall be at equi-distance in the balance portion of carriageway. For paved shoulder an additional level shall be taken at the centre of the shoulder.

Suitable references for the transverse grid lines should be left in the form of embedded bricks on both ends or by other means so that it is possible to locate the grid points for level measurements after each successive course is laid. For pavement courses laid only over widening portions, at least one line of levels shall be taken on each strip of widening, or more depending on the width of widening as decided by the Engineer. Notwithstanding the above, the measurements may be taken at closer intervals also, if so desired by the Engineer, the need for which may arise particularly in the case of estimation of the volume of the material for profile corrective course (levelling course). The average thickness of the pavement course in any area shall be the arithmetic mean of the difference of levels before and after construction at all the grid points falling in that area, provided that the thickness of finished work shall be limited to those shown on the drawings or approved by the engineer in writing. As supplement to level measurements, the Engineer shall have the option to take cores/ make holes to check the depth of construction. The holes made and the portions cut for taking cores shall be made good by the Contractor by laying fresh mix/material including compacting as required at his-own cost immediately after the measurements are recorded.

8.20.4. Checking of Pavement Thickness for Payment on Area Basis

Where payment for any bituminous course in Section 500 is allowed to be made on the area basis, the Engineer may have its thickness checked with the help of a suitable penetration gauge at regular intervals or other means as he may decide.

8.20.5. Measurement of Bituminous Courses for Payment on Weight Basis

Plant-mixed bituminous materials for pavement courses, where specifically designated in the contract to be paid on weight basis, shall be weighed on accurate scales approved by the Engineer. Approved scales shall mean scales that are of size, capacity, kind and type suitable for the weighing to be done, and these shall be properly installed and maintained. Prior to the use of the scales and as frequently thereafter as the Engineer may deem necessary to ensure accuracy, the scales shall be checked and approved by the Engineer, or the Engineer may direct the Contractor to have the scales checked by other competent agency at the cost of the Contractor. Location of the scales shall be as designated by the Engineer. Trucks used for

hauling the material to be weighed shall be weighed empty daily at such times as the Engineer directs, and each truck shall bear a plainly legible identification mark. For materials specified to be measured by weight, the Engineer will have the option to make measurements of the finished work by volume in accordance with Section 113.3 and such volumes shall be converted into weight for payment purposes. The factor for conversion from volume measurement to weight measurement shall be computed from the representative density of the compacted material at site determined at locations approved by the Engineer.

8.21. Scope of rates for different items of work

8.21.1. For item rate contracts, the contract unit rates for different items of work shall be payment in full for completing the work to the requirements of the Specifications including full compensation for all the operations detailed in the relevant Sections of these Specifications under "Rates". In the absence of any directions to the contrary, the rates are to be considered as the full inclusive rate for finished work covering all labour, materials, wastage, temporary work, plant, equipment, over-head charges and profit as well as the general liabilities, performance of other obligations, insurance and risks arising out of the Conditions of Contract.

8.21.2. The item rates quoted by the Contractor shall, unless otherwise specified, also include compliance with/supply of the following:

- (i) General works such as setting out, clearance of site before setting out and clearance of works after completion;
- (ii) A detailed programme using modern project management software for the construction and completion of the work giving, in addition to construction activities, detailed network activities for the submission and approval of materials, procurement of critical materials and equipment, fabrication of special products/equipment and their installation and testing, for all activities of the Engineer/Employer that are likely to affect the progress of work, etc., including updating of all such activities on the basis of the decisions taken at the periodic site review meetings or as directed by the Engineer;
- (iii) Samples of various materials proposed to be used on the Works for conducting tests thereon as required as per the provisions of the Contract;
- (iv) Design of mixes as per the relevant Sections of the Specifications giving proportions of ingredients, sources of aggregates and binder along with accompanying trial mixes as per the relevant Sections of these Specifications to be submitted to the Engineer for his approval before use on the Works;
- (v) Cost of laying trial stretches;
- (vi) Detailed drawings as per Clause 107.
- (vii) Detailed design calculations and drawings for all Temporary Works (such as form-work, staging, centering, specialized constructional handling and launching equipment and the like);
- (viii) Detailed drawings for templates, support and end anchorage, details for pre-stressing cable profiles, bar bending and cutting schedules for reinforcement, material lists for fabrication of structural steel, etc.;
- (ix) Mill test reports for all mild and high tensile steel and cast steel as per the relevant provisions of the Specifications;
- (x) Testing of various finished items and materials including bitumen, cement, concrete, bearings as required under these Specifications and furnishing test reports/certificates;
- (xi) Inspection Reports in respect of formwork, staging, reinforcement and other items of work as per the relevant Specifications;
- (xii) Any other data which may be required as per these Specifications or the Conditions of Contract

or any other annexures/schedules forming part of the Contract;

- (xiii) Any other item incidental to work which is necessary for complying with the provisions of the Contract;
- (xiv) All temporary works, formwork and false work not included as separate item in the BOQ;
- (xv) Establishing and running a laboratory with facilities for testing for various items or works as specified in Section 900 and other relevant Sections;
- (xvi) Cost of in-built provisions for Quality Assurance;
- (xvii) Cost of safeguarding the environment; and
- (xviii) Cost of providing "as-built drawings" in original and two sets of prints.

8.21.3. Portions of road works beyond the limits and/or any other work may be got constructed by the Employer directly through other agencies. Accordingly, other agencies employed by the Employer may be working in the vicinity of the Works being executed by the Contractor. The Contractor shall liaise with such agencies and adjust his construction programme for the completion of work accordingly and no claim or compensation due to any reason whatsoever will be entertained on this account. The Employer will be indemnified by the Contractor for any claims from other agencies on this account.

8.22. Methodology and sequence of work

8.22.1. Prior to start of the construction activities at site, the Contractor shall, within 15 days after the date of the agreement unless otherwise stipulated in the Contract, submit to the Engineer for approval, the detailed method statement. The method statement shall be submitted in two parts.

8.22.2. The general part of the method statement shall describe the Contractor's proposals regarding preliminary works, common facilities and other items that require consideration at the early stage of the contract. The general part shall include information on:

- (i) Sources of materials like coarse aggregates and fine aggregates, quantity and quality of materials available in different sources.
- (ii) Sources of manufactured materials like bitumen, cement, steel reinforcement, pre-stressing strands and bearings etc. He shall also submit samples/test certificates of materials for consideration of the Engineer;
- (iii) Locations of the site facilities such as batching plant, hot mix plant, crushing plant, etc.;
- (iv) Details of facilities available for transportation of men/material and equipment;
- (v) Information on procedure to be adopted by the Contractor for prevention and mitigation of negative environmental impact due to construction activities;
- (vi) Safety and traffic arrangement during construction.
- (vii) Implementation of activities provided in the Environmental Management Plan.
- (viii) Any other information required by the Engineer.

The general part of the QA programme under Section 105.3 shall accompany the method statement.

8.22.3. Special part of the method statement shall be submitted to the Engineer by the Contractor for each important item of work as directed by the Engineer. The statement shall be submitted at least 4 weeks in advance of the commencement of the activity of item of work unless otherwise stipulated in the contract. The statement shall give information on:

- (a) Details of the personnel both for execution and quality control of the work.

- (b) Equipment deployment with details of the number of units, capacity, standby arrangement.
- (c) Sequence of construction and details of temporary or enabling works like diversion, cofferdam, formwork including specialized formwork for superstructure, details of borrow areas, method of construction of embankment, sub-grade and pavement, pile concreting, proprietary processes and products and equipment's to be deployed. Wherever required technical literature, design calculations and drawings shall be included in the method statement.
- (d) Testing and acceptance procedure including documentation.
- (e) The special part of the QA programme under Sub-Section 105.3 for the particular item of work shall accompany the method statement for the concerned activity. The Engineer shall examine and approve the method statement with the required modifications. The modified method statement if required shall be submitted within 14 days of the receipt of the Engineer's approval. The sole responsibility for adequacy and safety of the method adopted by the Contractor shall rest on the Contractor irrespective of any approval given by the Engineer.

8.22.4. Approval of Proprietary Products/Processes/Systems

Within 90 days of the signing of agreement, the Contractor shall submit the following information for all proprietary products, process or any other item proposed to be used in the work, for approval of the Engineer.

- (a) Name of the manufacturer and name of the product/process/system along with authenticated copies of the license/collaboration agreement.
- (b) General features of the product/process/system.
- (c) Details of the product development and development testing.
- (d) Acceptance test and criteria.
- (e) Installation procedure.
- (f) Maintenance procedure and schedule.
- (g) Warranty proposal.

The Engineer may order additional test for the purpose of acceptance. Additional charges for test, if any, for the product/process/system shall be borne by the Contractor.

8.23. Crushed stone aggregates

Where the terms crushed gravel/shingle, crushed stone, broken stone or stone aggregate appear in any part of the Contract Documents or Drawings issued for work, they refer to crushed gravel/crushed shingle/crushed stone aggregate obtained from integrated crushing plant having appropriate primary crusher, secondary cone crusher, vertical shaft impactor and vibratory screen unless specified otherwise. Stone retained on 4.75 mm sieve shall have at least two faces fractured

8.24. Supply of quarry samples

The Contractor at his cost shall submit raw and processed samples of the mineral aggregates from the approved quarry.

8.25. Approval of materials Approval of all sources of material for work shall be obtained in writing from the Engineer before their use on the works.

8.26. Use of surfaces by traffic

Ordinarily, no construction traffic shall be allowed on pavement under construction unless authorized by the Engineer. Even in that case, the load and intensity of construction traffic should be so regulated that no damage is caused to the sub-grade or pavement layers already constructed. Where necessary, service roads shall be constructed for this purpose and the same shall be considered as incidental to the work. The wheels or the tracks of plant moving over the various pavement courses shall be kept free of deleterious materials. Bituminous base course shall be kept clean and uncontaminated as long as the same remains uncovered by a wearing course or surface treatment. The only traffic permitted access to the base/binder course shall be that engaged in laying and compacting the wearing course or that engaged on such surface treatment where the base/binder course is to be blinded and/or surface dressed. Should the base/binder course or tack coat on the base/binder course become contaminated, the Contractor shall make good by cleaning it to the satisfaction of the Engineer, and if this is impracticable, by removing the layer and replacing it to Specifications without any extra cost to the employer. On Dry Lean Concrete sub-base, no heavy commercial vehicles like trucks and buses shall be permitted after its construction. Light vehicles, if unavoidable, may, however, be allowed after 7 days of its construction with prior approval of the Engineer. No vehicular traffic, shall be allowed on a finished concrete pavement for a period of 28 days of its construction and until the joints are permanently sealed and cured.

8.27. Field Laboratory

8.27.1. Scope

The work covers the provision and maintenance of an adequately equipped field laboratory as required for site control on the quality of materials and the works.

8.27.2. Description

The Contractor shall arrange to provide fully furnished and adequately equipped field laboratory. The field laboratory shall preferably be located adjacent to the site office of the Engineer and provided with amenities like water supply, electric supply etc. as for the site office of the Engineer as described in this Section. The layout and size of the field laboratory shall be as indicated in the drawings. In case no drawings is furnished, the laboratory shall include space for the storage of samples, equipment, laboratory tables and cupboards, working space for carrying out various laboratory tests, a wash basin, toilet facility and a curing tank for the curing of samples, around 4 m x 2 m x 1 m in size and a fume chamber. Wooden/concrete working table with a working platform area of about 1 m x 10m shall be provided against the walls. Wooden cupboards above and below the working tables shall be provided to store accessories such as, sample moulds etc. At least 4 racks of slotted angles and M.S. sheets the size 1800 mm x 900x 375 mm and at least 6 stools for laboratory test operators shall also be provided. The items of laboratory equipment shall be provided in the field laboratory depending upon the items to be executed as per Table 100-2(PI referred Morth 5th revision).

8.27.3. Ownership

The field laboratory building and equipment shall be the property of the Contractor. The Employer and the Engineer shall have free access to the laboratory.

8.27.4. Maintenance

The Contractor shall arrange to maintain the field laboratory in a satisfactory manner until the issue of Taking over Certificate for the completed work. Maintenance includes all activities described in Section 120.4(PI referred Morth 5th revision).

8.27.5. Rate

Provision and maintenance of the field laboratory is not a payable item as it is incidental to the work.

8.28. SUPPLY OF PROJECT RECORD

8.28.1. Scope

The work covers the supply digital record of project events in digital format (DVD/Flash Drive) including coloured photographs both in digital format as well as mounted on albums to serve as a permanent record of the work needed for an authentic documentation, as approved by the Engineer.

8.28.2. Description

The Contractor shall provide the following project records in digital format (DVD/Flash Drive) as directed by the Engineer:

- (i) Record of work in each work front: It shall cover the status of each work front before start of work, during various stages of construction and after completion duly including the arrangements made (day & night) for traffic during construction (This shall be need based or as directed by the Engineer).
- (ii) Record of quarry sites, plant sites, camp sites including labour camps, haul roads, access roads, etc. on quarterly basis.
- (iii) Record of all accidents on project road/various sites (quarry, plant, camp, etc.)

A professional shall take the record with a digital camera capable of taking still as well as video images having the facility to record the date and the background commentary. The Contractor shall keep separate discs/drives, one with the Engineer and the other with the Employer and update the data in these discs/drives on monthly basis. Separately, a video (in digital format) of maximum one hour duration covering interesting and novel features of the work duly editing the above master disc/drive shall also be maintained, one copy each kept with the Engineer and the Employer and updated on monthly basis. All recording shall be done in the presence of the Engineer's Representative who will certify in writing the recording.

8.28.3. Measurements for Payment

Supply of two copies of all digital records as above and color record photographs both in digital format as well as mounted in the albums project shall be measured as one item for the project. Supply of additional prints of color record photograph if requested shall be measured in number of additional prints supplied. The supply of "as-built" drawings in digital format and in hard copies is incidental to the work and shall not be a payable item.

8.28.4. Rate

Supply of project record in digital format in two copies (one for the Engineer and the other for the Employer) including video recordings updated on monthly basis throughout the construction period shall be measured as one single item.

9.1. PROTECTION OF THE ENVIRONMENT

9.2. GENERAL

9.2.1. This Appendix sets out limitations on the Contractor's activities specifically intended to protect the environment.

9.2.2. The Contractor shall take all necessary measures and precautions and otherwise ensure that the execution of the works and all associated operations on or off site are carried out in conformity with statutory and regulatory environmental requirements including those prescribed elsewhere in these specifications.

9.2.3. The Contractor shall take all measures and precautions to avoid any nuisance or disturbance arising from the execution of the Works. This shall wherever possible be achieved by suppression of the nuisance at source rather than abatement of the nuisance once generated.

9.2.4. In the event of any spoil, debris, waste or any deleterious substance from the site being deposited on any adjacent land, the Contractor shall immediately remove all such material and restore the affected area to its original state to the satisfaction of the engineer.

9.3. WATER QUALITY

9.3.1. The Contractor shall prevent any interference with the supply to or abstraction from, and prevent any pollution of, water resources (including underground percolating water) as a result of the execution of the Works.

9.3.2. Areas where water is regularly or repetitively used for dust suppression purposes shall be laid to fall to specially-constructed settlement tanks to permit sedimentation of particulate matter. After settlement, the water may be reused for dust suppression and rinsing.

9.3.3. All water and other liquid waste products arising on the site shall be collected and disposed of at a location on or off the site and in a manner that shall not cause nuisance or pollution.

9.3.4. The Contractor shall not discharge or deposit any matter arising from the execution of the Works into any waters except with the permission of the Engineer and the regulatory authorities concerned.

9.3.5. The Contractor shall at all times ensure that all existing stream courses and drains within, and adjacent to, the site are kept safe and free from any debris and any materials arising from the Works.

9.3.6. The Contractor shall protect all watercourses, waterways, ditches, canals, drains, lakes and the like from pollution as a result of the execution of the Works.

9.4. AIR QUALITY

9.4.1. The Contractor shall devise and arrange methods of working to minimize dust, gaseous or other airborne emissions and carry out the Works in such a manner as to minimize adverse impacts on air quality.

9.4.2. The Contractor shall utilize effective water sprays during delivery, manufacture, processing and handling of materials when dust is likely to be created, and to dampen stored materials during dry and windy weather. Stockpiles of friable materials shall be covered with clean tarpaulins, with application of sprayed water during dry and windy weather. Stockpiles of material or debris shall be dampened prior to their movement, except where this is contrary to the Specifications.

9.4.3. Any vehicle with an open load-carrying area used for transporting potentially dust producing material

shall have properly fitting side and tail boards. Materials having the potential to produce dust shall not be loaded to a level higher than the side and tail boards, and shall be covered with a clean tarpaulin in good condition. The tarpaulin shall be properly secured and extended at least 300 mm over the edges of the side and tail boards.

9.4.4. In the event that the Contractor is permitted to use gravel or earth roads for haulage, he shall provide suitable measures for dust palliation, if these are, in the opinion of the Engineer, necessary. Such measures may include sprinkling water on the road surface at regular intervals.

9.5. NOISE

9.5.1. The Contractor shall consider noise abatement measures in his planning and execution of the Works.

9.5.2. The Contractor shall take all necessary measures so that the operation of all mechanical equipment and construction processes on and off the site shall not cause any unnecessary or excessive noise, taking into account applicable environmental requirements. The Contractor shall use all necessary measures and shall maintain all plant and silencing equipment in good condition so as to minimize the noise emission during construction works.

9.6. CONTROL OF WASTES

9.6.1. The Contractor shall control the disposal of all forms of waste generated by the construction operations and in all associated activities. No uncontrolled deposition or dumping shall be permitted. Wastes to be so controlled shall include, but shall not be limited to, all forms of fuel and engine oils, all types of bitumen, cement, surplus aggregates, gravels, bituminous mixes etc. The Contractor shall make specific provision for the proper disposal of these and any other waste products, conforming to local regulations and acceptable to the Engineer.

9.7. EMERGENCY RESPONSE

9.7.1. The Contractor shall plan and provide for remedial measures to be implemented in the event of occurrence of emergencies such as spillages of oil or bitumen or chemicals.

9.7.2. The Contractor shall provide the Engineer with a statement of the measures he intends to implement in the event of such an emergency, which shall include a statement of how he intends to provide personnel adequately trained to implement such measures.

9.8. MEASUREMENT

9.8.1. No separate measurement shall be made in respect of compliance by the Contractor with these provisions. The Contractor shall be deemed to have made allowance for such compliance with these provisions in the preparation of his prices for items of work included in the Bill of Quantities and full compensation for such compliance will be deemed to be covered by them.

9.9. CLEARING AND GRUBBING, (MORTH 5th Revised-Section-200)

9.9.1. Cleaning and Grubbing

9.9.2. Scope: -This work shall consist of cutting, removing and disposing of all materials such as trees, bushes, shrubs, stumps, roots, grass, weeds, rubbish, top organic soil, etc. to an average depth of 150 mm in thickness, which in the opinion of the Engineer are unsuitable for incorporation in the works, from the area of road land containing road embankment, drains, cross-drainage structures and such other areas as may be specified on the drawings or by the Engineer. It shall include necessary excavation, backfilling of pits resulting from uprooting of trees and stumps to required compaction,

handling, salvaging, and disposal of cleared materials with all leads and lifts. Clearing and grubbing shall be performed in advance of earthwork operations and in accordance with the requirements of these Specifications.

9.9.3.Preservation of Property/Amenities:-Roadside trees, shrubs, any other plants, pole lines, fences, signs, monuments, buildings, pipelines, sewers and all highway facilities within or adjacent to the highway which are not to be disturbed shall be protected from injury or damage. The Contractor shall provide and install at his own cost, suitable safeguards approved by the Engineer for this purpose. During clearing and grubbing, the Contractor shall take all adequate precautions against soil erosion, water pollution, etc., and where required, undertake additional works to that effect vide Clause 306. Before start of operations, the Contractor shall submit to the Engineer for approval, his work plan including the procedure to be followed for disposal of waste materials, etc., and the schedules for carrying out temporary and permanent erosion control works as stipulated in Clause 306.3.

9.9.4.Methods, Tools and Equipment: -Only such methods, tools and equipment as are approved by the Engineer and which will not affect any property to be preserved shall be adopted for the Work. If the area has thick vegetation/roots/trees, a crawler or pneumatic tyred dozer of adequate capacity may be used for clearance purposes. The dozer shall have ripper attachments for removal of tree stumps. All trees, stumps, etc., falling within excavation and fill lines shall be cut to such depth below ground level that in no case these fall within 500 mm of the bottom of the subgrade. Also, all vegetation such as roots, under-growth, grass and other deleterious matter unsuitable for incorporation in the embankment subgrade shall be removed between fill lines to the Satisfaction of the Engineer. All branches of trees extending above the roadway shall be trimmed as directed by the Engineer. All excavations below the general ground level arising out of the removal of trees, stumps, etc., shall be filled with suitable material and compacted thoroughly so as to make the surface at these points conform to the surrounding area. Ant-hills both above and below the ground, as are liable to collapse and obstruct free subsoil water flow shall be removed and their workings, which may extend to several meters, shall be suitably treated.

9.9.5.Disposal of Materials:-All materials arising from clearing and grubbing operations shall be taken over and shall be disposed of by the Contractor at suitable disposal sites with all leads and lifts. The disposal shall be in accordance with local, State and Central regulations.

9.9.6.Measurements for Payment: -Clearing and grubbing for road embankment, drains and cross-drainage structures shall be measured on area basis in terms of hectares. Cutting of trees up to 300 mm in girth and removal of their stumps, including removal of stumps up to 300 mm in girth left over after trees have been cut by any other agency, and trimming of branches of trees extending above the roadway and backfilling to the required compaction shall be considered incidental to the clearing and grubbing operations. Clearing and grubbing of borrow areas shall be deemed to be a part of works preparatory to embankment construction and shall be deemed to have been included in the rates quoted for the embankment construction item and no separate payment shall be made for the same. Ground levels shall be taken prior to and after clearing and grubbing. Levels taken prior to clearing and grubbing shall be the base level and will be accordingly used for assessing the depth of clearing and grubbing and computation of quantity of any unsuitable material which is required to be removed. The levels taken subsequent to clearing and grubbing shall be the base level for computation of earthwork for embankment. Cutting of trees, excluding removal of stumps and roots of trees of girth above 300 mm shall be measured in terms of number according to the girth sizes given below :-

- (i) Above 300 mm to 600 mm
- (ii) Above 600 mm to 900 mm
- (iii) Above 900 mm to 1800 mm
- (iv) Above 1800 mm

Removal of stumps and roots including backfilling with suitable material to required compaction shall be a separate item and shall be measured in terms of number according to the sizes given below:-

- (i) Above 300 mm to 600 mm
- (ii) Above 600 mm to 900 mm
- (iii) Above 900 mm to 1800 mm
- (iv) Above 1800 mm

For the purpose of cutting of trees and removal of roots and stumps, the girth shall be measured at a height of 1 m above ground or at the top of the stump if the height of the stump is less than one meter from the ground.

9.9.7. Rates:-The Contract unit rates for the various items of clearing and grubbing shall be payment in full for carrying out the required operations including full compensation for all labour, materials, tools, equipment and incidentals necessary to complete the work. These will also include removal of stumps of trees less than 300 mm girth excavation and backfilling to required density, where necessary, and handling, giving credit towards salvage value disposing of the cleared materials with all lifts and leads. Clearing and grubbing done in excess of 150 mm by the Contractor shall be made good by the Contractor at his own cost as per Clause 301.3.3 to the satisfaction of the Engineer prior to taking up earthwork. Where clearing and grubbing is to be done to a level beyond 150 mm, due to site considerations, as directed by the Engineer, the extra quantity shall be measured and paid separately. The Contract unit rate for cutting trees of girth above 300 mm shall include handling, giving credit towards salvage value disposing of the cleared materials with all lifts and leads. The Contract unit rate for removal of stumps and roots of trees girth above 300 mm shall include excavation and backfilling with suitable material to required compaction, handling, giving credit towards salvage value disposing of the cleared materials with all lifts and leads. The Contract unit rate is deemed to include credit towards value of usable materials, salvage value of unusable materials and off-set price of cut trees and stumps belonging to the Forest Department. The off-set price of cut trees and stumps belonging to the Forest Department shall be deducted from the amount due to the Contractor and deposited with the State Forest Department. In case the cut trees and stumps are required to be deposited with the Forest Department the Contractor shall do so and no deduction towards the off-set price shall be effected. The offset price shall be as per guidelines / estimates of the State Forest Department. Where a Contract does not include separate items of clearing and grubbing, the same shall be considered incidental to the earthwork items and the Contract unit prices for the same shall be considered as including clearing and grubbing operations.

9.10. Dismantling structures/pavements

9.10.1. Scope:-This work shall consist of dismantling and removing existing culverts, bridges, pavements, kerbs and other structures like guard-rails, fences, utility services, manholes, catch basins, inlets, etc., from the right of way which in the opinion of the Engineer interfere with the construction of road or are not suitable to remain in place, disposing of the surplus/unsuitable materials and backfilling to after the required compaction as directed by the Engineer. Existing culverts, bridges, pavements and other structures which are within the highway and which are designated for removal, shall be removed up to the limit and extent specified in the drawings or as indicated by the Engineer. Dismantling and removal operations shall be carried out with such equipment and in such a manner as to leave undisturbed, adjacent pavement, structures and any other work to be left in place. All operations necessary for the removal of any existing structure which might endanger new construction shall be completed prior to the start of new work.

9.10.2. Dismantling Culverts and Bridges: -The structures shall be dismantled carefully and the resulting materials so removed as not to cause any damage to the part of the structure to be retained and any other properties or structures nearby. Unless otherwise specified, the superstructure portion of culverts/bridges shall be entirely removed and other parts removed up to at least 600 mm below the

sub-grade, slope face or original ground level whichever is the lowest or as necessary depending upon the interference they cause to the new construction. Removal of overlying or adjacent material, if required in connection with the dismantling of the structures, shall be incidental to this item. Where existing culverts/bridges are to be extended or otherwise incorporated in the new work, only such part or parts of the existing structure shall be removed as are necessary and directed by the Engineer to provide a proper connection with the new work. The connecting edges shall be cut, chipped and trimmed to the required lines and grades without weakening or damaging any part of the structure to be retained. Due care should be taken to ensure that reinforcing bars which are to be left in place so as to project into the new work as dowels or ties are not injured during removal of concrete. Pipe culverts shall be carefully removed in such a manner as to avoid damage to the pipes. Steel structures shall, unless otherwise provided, be carefully dismantled in such a manner as to avoid damage to members thereof. If specified in the drawings or directed by the Engineer that the structure is to be removed in a condition suitable for re-erection, all members shall be match-marked by the Contractor with white lead paint before dismantling. end pins, nuts, loose plates, etc. shall be similarly marked to indicate their proper location. all pins, pin holes and machined surfaces shall be painted with a mixture of white lead and tallow and all loose parts shall be securely wired to adjacent members or packed in boxes. Timber structures shall be removed in such a manner as to avoid damage to such timber or lumber having salvage value as is designated by the Engineer.

9.10.3. Dismantling Pavements and Other Structures: -In removing pavements, kerbs, gutters, and other structures like guard-rails, fences, manholes, catch basins, inlets, etc., where portions of the existing construction are to be left in the finished work, the same shall be removed to an existing joint or cut and chipped to a true line with a face perpendicular to the surface of the existing structure. Sufficient removal shall be made to provide for proper grades and connections with the new work as directed by the Engineer. All concrete pavements, base courses in carriageway and shoulders etc., designated for removal shall be broken to pieces whose volume shall not exceed 0.02 cum and used with the approval of the Engineer or disposed of.

9.10.4. Back-filling: -Holes and depressions caused by dismantling operations shall be backfilled with excavated or other approved materials and compacted to required density as directed by the Engineer.

9.10.5. Disposal of Materials: -All surplus materials shall be taken over by the Contractor which may either be re-used with the approval of the Engineer or disposed of with all leads and lifts.

9.10.6. Measurements for Payment:-The work of dismantling shall be paid for in units indicated below by taking measurements before and after, as applicable:

- (i) Dismantling brick/stone masonry/ concrete (plain and reinforced)..... Cum
- (ii) Dismantling flexible and cement concrete pavement..... Cum
- (iii) Dismantling steel structures..... tonne
- (iv) Dismantling timber structures..... cum.
- (v) Dismantling pipes, guard rails, kerbs, gutters and fencing..... linearm.
- (vi) Utility services..... No.

9.10.7. Rates: -The Contract unit rates for the various items of dismantling shall be paid in full for carrying out the required operations including full compensation for all labour, materials, tools, equipment, safe guards and incidentals necessary to complete the work. The rates will include excavation and backfilling to the required compaction and for handling, giving credit towards salvage value disposing of dismantled materials with all lifts and leads.

10.1. **EARTHWORK, EROSION CONTROL AND DRAINAGE (MORTH 5th Revised-Section-300)**

10.2. **Excavation for Roadway and Drains**

10.2.1. Scope:-This work shall consist of excavation, removal and disposal of materials necessary for the construction of roadway, side drains and waterways in accordance with requirements of these Specifications and the lines, grades and cross-sections shown in the drawings or as indicated by the Engineer. It shall include the hauling and stacking of or hauling to sites of embankment and subgrade construction suitable cut materials as required, as also the disposal of unsuitable cut materials in specified manner, with all leads and lifts, reuse of cut materials as may be deemed fit, trimming and finishing of the road to specified dimensions or as directed by the Engineer.

10.2.2. **Classification of Excavated Material**

10.2.2.1. Classification:

The Engineer in the following shall classify all materials involved in excavation manner:

- (a) Soil :This shall comprise topsoil, turf, sand, silt, loam, clay, mud, peat, black cotton soil, soft shale or loose moorum, a mixture of these and similar material which yields to the ordinary application of pick, spade and/or shovel, rake or other ordinary digging equipment. Removal of gravel or any other modular material having dimension in anyone direction not exceeding 75 mm shall be deemed to be covered under this category.
- (b) Ordinary Rock (not requiring blasting) This shall include:
 - (i) Rock types such as laterites, shales and conglomerates, varieties of limestone and sandstone etc., which may be quarried or split with crow bars, also including any rock which in dry state may be hard, requiring blasting but which, when wet, becomes soft and manageable by means other than blasting.
 - (ii) Macadam surfaces such as water bound and bitumen bound. soling of roads, cement concrete pavement, cobblestone, etc. compacted moorum or stabilized soil requiring use of pickaxe or Shovel or both.
 - (iii) lime concrete, stone masonry and brick work in lime/cement mortar below ground level, reinforced cement concrete which may be broken up with crow bars or picks and stone masonry in cement mortar below ground level; and
 - (iv) Boulders, which do not require blasting found lying loose on the surface or embedded in riverbed, soil, talus, slope wash and terrace material of dissimilar origin.

10.2.2.2. Authority for Classification:-

The Engineer shall decide the classification of excavation and his decision shall be final and binding on the Contractor. Merely the use of explosives in excavation will not be considered as a reason for higher classification unless blasting is clearly necessary in the opinion of the Engineer.

10.2.3. **Construction Operations: -**

10.2.3.1. Setting Out:-After the site has been cleared as per Clause 201, the limits of excavation shall be set out true to lines, curves, slopes, grades and sections as shown on the drawings or as directed by the Engineer. Clause 109 shall be applicable for the setting out operations.

10.2.3.2. Stripping and Storing Topsoil:-When so directed by the Engineer, the topsoil existing over the sites of excavation shall be stripped to specify depths and stockpiled at designated locations for re-use in covering embankment slopes, cut slopes, berms and other disturbed areas where re-vegetation is desired in accordance with Clause 305.3.3. Prior to stripping the topsoil, all trees, shrubs etc.

shall be removed along with their roots, with approval of the Engineer.

10.2.3.3. **Excavation-General:-**All excavations shall be carried out in conformity with the directions laid here-in-under and in a manner approved by the Engineer. The work shall be so done that the suitable materials Available from excavation are satisfactorily utilized as deemed fit or as approved by the Engineer. While planning or executing excavations, the Contractor shall take all adequate precautions against soil erosion, water pollution etc. as per Clause 306, and take appropriate drainage measures to keep the site free of water in accordance with Clause 311. The excavations shall conform to the lines, grades, side slopes and levels shown on the drawings or as directed by the Engineer. The Contractor shall not excavate outside the limits of excavation. Subject to the permitted tolerances, any excess depth/width excavated beyond the specified levels/dimensions on the drawings shall be made good at the cost of the Contractor with suitable material of characteristics similar to that removed and compacted to the requirements of Clause 305. All debris and loose material on the slopes of cuttings shall be removed. No backfilling shall be allowed to obtain required slopes excepting that when boulders or soft materials are encountered in cut slopes, these shall be excavated to approved depth on instructions of the Engineer and the resulting cavities filled with suitable material and thoroughly compacted in an appropriate manner. After excavation, the sides of excavated area shall be trimmed and the area contoured to minimize erosion and ponding, allowing for natural drainage to take place.

10.2.3.4. **Methods, Tools and Equipment:-**Only such methods, tools and equipment as approved by the Engineer shall be adopted/ used in the work. If so desired by the Engineer, the Contractor shall demonstrate the efficacy of the type of equipment to be used before the commencement of work.

10.2.3.5. **Excavation for Surface/Subsurface Drains:-**Where the Contract provides for construction of surface/sub-surface drains, the same shall be done as per Clause 309. Excavation for these drains shall be carried out in proper sequence with other works as approved by the Engineer.

10.2.3.6. If water is met with in the excavations due to springs, seepage, rain or other causes, it shall be removed by suitable diversions, pumping or bailing out and the excavation kept dry whenever so required or directed by the Engineer. Care shall be taken to discharge the drained water into suitable outlets as not to cause damage to the works, crops or any other property. Due to any negligence on the part of the Contractor, if any such damage is caused, it shall be the sole responsibility of the Contractor to repair restore to the original condition at his own cost or compensate for the damage.

10.2.3.7. **Use and Disposal of Excavated Materials:-**All the excavated materials shall either be reused with the approval of the Engineer or disposed of with all leads and lifts as directed by the Engineer.

10.2.3.8. **Permission of the Engineer.** The Contractor at his own cost shall make any damage arising out of such use good.

10.2.4. **Preservation of Property:-**The Contractor shall undertake all reasonable precautions for the protection and preservation of any or all existing roadside trees, drains, sewers, sub-surface drains, pipes, conduits and any other structures under or above ground, which may be affected by construction operations and which, in the opinion of the Engineer, shall be continued in use without any change. Safety measures taken by the Contractor in this respect, shall be got approved from the Engineer. However, if any, of these objects is damaged because of the Contractor's negligence, it shall be replaced or restored to the original condition at his cost. If the Contractor fails to do so, within the required time as directed by the Engineer or if, in the opinion of the Engineer, the actions initiated by the Contractor to replace restore the damaged objects are not satisfactory, the Engineer shall arrange the replacement/restoration directly through any other agency at the risk and cost of the Contractor after issuing prior notice to the effect.

10.2.5. **Preparation of Cut Formation:-**The cut formation, which serves as a sub-grade, shall be prepared to receive the subbase base course as directed by the Engineer. Where the material in the subgrade

has a density less than specified in Table 300-1, the same shall be loosened to a depth of 500 mm and compacted in layers in accordance with the requirements of Clause 305 adding fresh material, if any required, to maintain the formation level as shown on the drawings. Any unsuitable material encountered in the subgrade level shall be removed as directed by the Engineer, replaced with suitable material and compacted in accordance with Clause 305.

10.2.6. In rocky formations, the surface irregularities shall be corrected and the levels brought up to the specified elevation with granular base material as directed by the Engineer, laid and compacted in accordance with the respective Specifications for these materials. The unsuitable material shall be disposed of in accordance with Clause 301.3.11. After satisfying the density requirements, the cut formation shall be prepared to receive the sub-base/base course in accordance with Clauses 310 and 311.

10.2.7. **Finishing Operations:**-Finishing operations shall include the work of properly shaping and dressing all excavated surfaces. When completed, no point on the slopes shall vary from the designated slopes by more than 150 mm measured at right angles to the slope, except where excavation is in rock (ordinary or hard) where no point shall vary more than 300 mm from the designated slope. In no case shall any portion of the slope encroach on the roadway. The finished cut formation shall satisfy the surface tolerances described in Clause 902. Where directed, the topsoil removed and conserved (Clauses 301.3.2 and 305.3.3) shall be spread over cut slopes, shoulders and other disturbed areas. Slopes may be roughened and moistened slightly, prior to the application of topsoil, in order to provide satisfactory bond. The depth of topsoil shall be sufficient to sustain plant growth, the usual thickness being from 75 mm to 100 mm.

10.2.8. **Measurements for Payment:**-Excavation for roadway shall be measured by taking cross-sections at suitable intervals before the excavation starts (after clearing and grubbing/stripping etc. as the case may be) and after its completion and computing the volumes in cum. by the method of average end areas for each class of material encountered. Where it is not feasible to compute volumes by this method because of erratic location of isolated deposits, the volumes shall be computed by other accepted methods. At the option of the Engineer, the Contractor shall leave depth indicators during excavations of such shape and size and in such positions as directed so as to indicate the original ground level as accurately as possible. The Contractor shall see that these remain intact till the final measurements are taken. For rock excavation, the overburden shall be removed first so that necessary cross-sections could be taken for measurement. Where cross-sectional measurements could not be taken due to irregular configuration or where the rock is admixed with other classes of materials, the volumes shall be computed on the basis of measurement of stacks of excavated rubble allowing a deduction of 35% therefrom. When volume is calculated on the basis of measurement of stacks of the excavated material other than rock, a deduction of 16% of stacked volume shall be allowed. Works involved in the preparation of cut formation shall be measured in units indicated below:

10.2.9. Rates

10.2.9.1. The Contract unit rates for the items of roadway and drain excavation shall be payment in full for carrying out the operations required for the individual items including full compensation for:

- (i) Setting out;
- (ii) Transporting the excavated materials for use or disposal with all leads and lifts by giving suitable credit towards the cost of re-usable material and salvage value of unusable material;
- (iii) Trimming bottoms and slopes of excavation;
- (iv) Dewatering;
- (v) Keeping the work free of water as per Clause 311;

- (vi) Arranging disposal sites; and
- (vii) All labour, materials, tools, equipment. Safety measures, testing and incidentals necessary to complete the work to Specifications. Where presplitting of rock is prescribed, Clause 303.5 shall govern it.

10.2.9.2. The Contract unit rate for loosening and compacting the loosened materials at subgrade shall include full compensation for loosening to the specified depth, including breaking clods, spreading in layers, watering where necessary and compacting to the requirements.

10.2.9.3. Clauses 3.9.1 and 3.8 shall apply as regards Contract unit rate for item of removal of unsuitable material and replacement with suitable material respectively.

10.2.9.4. The Contract unit rate for item of preparing rocky sub-grade as per Clause 301.6 shall be full compensation for providing, laying and compacting granular base material for correcting surface irregularities including all materials, labour and incidentals necessary to complete the work and all leads and lifts.

10.2.9.5. The Contract unit rate for the items of stripping and storing topsoil and of reapplication of topsoil shall include full compensation for all the necessary operations including all lifts and leads.

10.3. Excavation for structures

10.3.1. **Scope:**-Excavation for structures shall consist of the removal of material for the construction of foundations for bridges, culverts, retaining walls, headwalls, cutoff walls, pipe culverts and other similar structures, in accordance with the requirements of these Specifications and the lines and dimensions shown on the drawings or as indicated by the Engineer. The work shall include construction of the necessary cofferdams and cribs and their subsequent removal; all necessary sheeting, shoring, bracing, draining and pumping; the removal of all logs, stumps, grubs and other deleterious matter and obstruction, necessary for placing the foundations; trimming bottoms of excavations; backfilling and clearing up the site and the disposal of all surplus material.

10.3.2. **Borrow Materials:**-The arrangement for the source of supply of the material for embankment and sub-grade and compliance with the guidelines, and environmental requirements, in respect of excavation and borrow areas as stipulated, from time to time by the Ministry of Environment and Forests, Government of India and the local bodies, as applicable shall be the sole responsibility of the Contractor. Borrow pits along the road shall be discouraged. If permitted by the Engineer, these shall not be dug continuously. Ridges of not less than 8 m width should be left at intervals not exceeding 300 m. Small drains shall be cut through the ridges to facilitate drainage. The depth of the pits shall be so regulated that their bottom does not cut an imaginary line having a slope of 1 vertical to 4 horizontal projected from the edge of the final section of the bank, the maximum depth in any case being limited to 1.5 m. Also, no pit shall be dug within the offset width of a minimum of 10m. Haulage of material to embankments or other areas of fill shall proceed only when sufficient spreading and compaction plant is operating at the place of deposition. Where the excavation reveals a combination of acceptable and unacceptable materials, the Contractor shall, unless otherwise agreed by the Engineer, carry out the excavation in such a manner that the acceptable materials are excavated separately for use in the permanent works without contamination by the unacceptable materials. The acceptable materials shall be stockpiled separately. The Contractor shall ensure that he does not adversely affect the stability of excavation or fills by the methods of stockpiling materials, use of plants or siting of temporary buildings or structures.

10.4. Compaction Requirements

The Contractor shall obtain representative samples from each of the identified borrow areas and have these tested at the site laboratory following a testing programme approved by the Engineer. It shall be ensured that the subgrade material when compacted to the density requirements as in Table 300-2 shall yield the

specified design CBR value of the sub-grade.

Table 300-2: Compaction Requirements for Embankment and Sub-grade

Type of work/material	Relative compaction as % of max. laboratory dry density as per 15:2720 (Part 8)
Subgrade and earthen shoulders	Not less than 97%
Embankment,	Not less than 95%

The Contractor shall at least 7 working days before commencement of compaction submit the following to the Engineer for approval:

- (i) The values of maximum dry density and optimum moisture content obtained in accordance with 18:2720 (Part 8), appropriate for each of the fill materials he intends to use.
- (ii) A graph of dry density plotted against moisture content from which each of the values in (i) above of maximum dry density and optimum moisture content were determined. The maximum dry density and optimum moisture content approved by the Engineer shall form the basis for compaction.

10.5. SURFACE/SUB-SURFACE DRAINS

10.6. **Scope:-**The work shall consist of constructing surface and/or sub-surface drains in accordance with the requirements of these Specifications and to the lines, grades, dimensions and other particulars shown on the drawings or as directed by the Engineer. Schedule of work shall be so arranged that the drains are completed in proper sequence with road works to ensure that no excavation of the completed road works is necessary subsequently or any damage is caused to these works due to lack of drainage.

10.7. **Surface Drains:-**Surface drains shall be excavated to the specified lines, grades, levels and dimensions to the requirements of Clause 301. The excavated material shall be removed from the area adjoining the drains and if found suitable, utilized in embankment/sub-grade construction. All unsuitable material shall be disposed of as directed. The excavated bed and sides of the drains shall be dressed to bring these in close conformity with the specified dimensions, levels and slopes.

Where so indicated, drains shall be lined or turfed with suitable materials in accordance with details shown on the drawings. All works on drain construction shall be planned and executed in proper sequence with other works as approved by the Engineer, with a view to ensuring adequate drainage for the area and minimizing erosion/sedimentation.

11.1. Granular Sub Base, WMM, Foot Path and Median (Morth 5th Revision Section-400)

11.2. Scope

This work shall consist of laying and compacting well-graded material on prepared subgrade in accordance with the requirements of these Specifications. The material shall be laid in one or more layers as sub-base or lower sub-base and upper sub-base (termed as subbase hereinafter) as necessary according to lines, grades and cross-sections shown on the drawings or as directed by the Engineer.

11.3. Materials

11.3.1. The material to be used for the work shall be natural sand, crushed gravel, crushed stone, crushed slag, or combination thereof depending upon the grading required. Use of materials like brick metal, Kankar and crushed concrete shall be permitted in the lower sub-base. The material shall be free from organic or other deleterious constituents and shall conform to the grading given in Table 400-1 and physical requirements given in Table 400-2. Grading III and IV shall preferably be used in lower sub-base. Grading V and VI shall be used as a sub-base-cum-drainage layer. The grading to be adopted for a project shall be as specified in the Contract. Where the sub-base is laid in two layers as upper sub-base and lower sub-base, the thickness of each layer shall not be less than 150 mm.

11.3.2. If the water absorption of the aggregates determined as per IS: 2386 (Part 3) is greater than 2 percent, the aggregates shall be tested for Wet Aggregate Impact Value (AIV) (IS: 5640). Soft aggregates like Kankar, brick ballast and laterite shall also be tested for Wet AIV (IS: 5640)

Table 400-1: Grading for Granular Sub-base Materials

	GRADING 1	GRADING 2	GRADING 3	GRADING 4	GRADING 5	GRADING 6
75MM	100	-	-	-	100	
53MM	80-100	100	100	100	80-100	100
26.5MM	55-90	70-100	55-75	50-80	55-90	75-100
9.50MM	35-65	50-80	-	-	35-65	55-75
4.75MM	25-55	40-65	10-30	15-35	25-50	30-55
2.36MM	20-40	30-50	-	-	10-20	10-25
0.85MM	-	-	-	-	2-10	-

Table 400-2: Physical Requirements for Materials for Granular Sub-base

Aggregate Impact Value	IS:2386 (Part 4)	Maximum 40
Liquid Limit	IS:2720 (Part 5)	Maximum 25
Plasticity Index	IS:2720 (Part 5)	Maximum 6
CBR at 98% dry density	IS2720 (Part 5)	Minimum 30 unless otherwise
(at 18:2720-Part 8)		specified in the Contract

11.4. Construction Operations

11.4.1. **Preparation of Sub-grade:**-Immediately prior to the laying of sub-base, the subgrade already finished to Clause 301 or 305 as applicable shall be prepared by removing all vegetation and other extraneous matter, lightly sprinkled with water, if necessary and rolled with two passes of 80-100 KN smooth wheeled roller.

11.4.2. **Spreading and compacting:**-The sub-base material of the grading specified in the Contract and a suitable mixer equipped with provision for controlled addition of water and mechanical mixing shall mix water mechanically. 80 as to ensure homogenous and uniform mix. The required water content shall be determined in accordance with 18:2720 (Part 8). The mix shall be spread on the prepared subgrade with the help of a motor grader of adequate capacity, its blade having hydraulic controls

suitable for initial adjustment and for maintaining the required slope and grade during the operation, or other means as approved by the Engineer. Moisture content of the mix shall be checked in accordance with IS:2720 (Part 2) and suitably adjusted so that, at the time of compaction, it is from 1 to 2 percent below the optimum moisture content. Immediately after spreading the mix, rolling shall be done by an approved roller. If the thickness of the compacted layer does not exceed 100 mm, a smooth wheeled roller of 80 to 100 kN weight may be used. For a compacted single layer up to 200 mm the compaction shall be done with the help of a vibratory roller of minimum 80 to 100 kN static weight capable of achieving the required compaction. Rolling shall commence at the lower edge and proceed towards the upper edge longitudinally for portions having unidirectional cross fall or on super elevation. For carriageway having cross fall on both sides, rolling shall commence at the edges and progress towards the crown. Each pass of the roller shall uniformly overlap not less than one-third of the track made in the preceding pass. During rolling, the grade and cross fall (camber) shall be checked and any high spots or depressions which become apparent, corrected by removing or adding fresh material. The speed of the roller shall not exceed 5 km per hour.

Rolling shall be continued till the density achieved is at least 98 percent of the maximum dry density for the material determined as per IS: 2720 (Part 8). The surface of any layer of material on completion of compaction shall be well closed, free from movement under compaction equipment and from compaction planes, ridges, cracks or loose material. All loose, segregated or otherwise defective areas shall be made good to the full thickness of layer and re-compacted.

11.5. Surface Finish and Quality Control of Work:-The surface finish of construction shall conform to the requirements of Clause 902. Control on the quality of materials and the Engineer in accordance with Section 900 shall exercise works.

11.6. Arrangements for Traffic:-During the period of construction, arrangements for the traffic shall be provided and maintained in accordance with Clause 112.

11.7. Measurements for Payment:-Granular sub-base shall be measured as finished work in position in cubic meters. The protection of edges of granular sub-base extended over the full formation as shown in the drawing shall be considered incidental to the work of providing granular sub-base and as such no extra payment shall be made for the same.

11.8. Rate:-The Contract unit rate for granular sub-base shall be payment in full for carrying out the required operations including full compensation for:

- (i) Making arrangements for traffic to Clause 112 except for initial treatment to verges, shoulders and construction of diversions;
- (ii) Supplying all materials to be incorporated in the work including all royalties, fees, rents where applicable with all leads and lifts;
- (iii) All labour, tools, equipment and incidentals to complete the work to the Specifications; IV) Carrying out the work in part widths of road where directed; and
- (iv) Carrying out the required tests for quality control.

11.9. Wet mix macadam sub-base/base

11.9.1. Scope: This work shall consist of laying and compacting clean, crushed, graded aggregate and granular material, premixed with water, to a dense mass on a prepared sub-grade/sub- Base or existing pavement as the case may be in accordance with the requirements of these Specifications. The material shall be laid in one or more layers as necessary to lines, grades and cross-sections shown on the approved drawings or as directed by the Engineer. The thickness of a single compacted Wet Mix

Macadam layer shall not be less than 75 mm. When vibrating or other approved types of compacting equipment are used, the compacted depth of a single layer of the sub-base course may be up to 200 mm with the approval of the Engineer.

11.9.2. Materials

11.9.2.1. Aggregates

11.9.2.2. **Physical Requirements:**-Course aggregates shall be crushed stone. If crushed gravel/shingle is used, not less than 90 percent by weight of the gravel/shingle pieces retained on 4.75 mm sieve shall have at least two fractured faces. The aggregates shall conform to the physical requirements set forth in Table 400-12. If the water absorption value of the coarse aggregate is greater than 2 percent, the soundness test shall be carried out on the material delivered to site as per IS: 2386 (Part-5).

Table 400-12: Physical Requirements of Coarse Aggregates for Wet Mix Macadam for Sub-base/Base Courses

Test	Test Method	
Los Angeles Abrasion value		Max.40%
Or	IS:2386 (Part-4)	
Aggregate Impact value		Max.30%
Combined Flakiness and Elongation indices	IS:2386 (Part-1)	Max.35%

11.9.2.3. **Grading Requirements:**-The aggregates shall conform to the grading given in Table 400-13.

Table 400-13: Grading Requirements of Aggregates for Wet Mix Macadam

IS Sieve Destination	% By Wt. Passing the I.S Sieve
53 mm	100
45 mm	95-100
26.5 mm	-
22.4 mm	60-80
11.2 mm	40-60
4.75 mm	25-40
2.36 mm	15-30
600 micron	8.22
75 micron	0-8

11.10. Material finer than 425 micron shall have Plasticity Index (PI) not exceeding 6. The final gradation approved within these limits shall be graded from coarse to fine and shall not vary from the low limit on one sieve to the high limit on the adjacent sieve or vice versa.

11.10.1. Construction Operations

11.10.1.1. **Provision of Lateral Confinement of Aggregates:**-While constructing wet mix macadam, arrangement shall be made for the lateral confinement of wet mix. This shall be done by laying materials in adjoining shoulders along with that of wet mix macadam layer and following the

sequence of operations described in Clause 404.3.3.

11.10.1.2. Preparation of Mix:-Wet Mix Macadam shall be prepared in an approved mixing plant of suitable capacity having provision for controlled addition of water and forced/ positive mixing arrangement like pug mill or pan type mixer of concrete batching plant. The plant shall have following features:

- (i) For feeding aggregates- three/ four bin feeders with variable speed motor
- (ii) Vibrating screen for removal of oversize aggregates
- (iii) Conveyor Belt
- (iv) Controlled system for addition of water
- (v) Forced/positive mixing arrangement like pug-mill or pan type mixer
- (vi) Centralized control panel for sequential operation of various devices and precise process control
- (vii) Safety devices Optimum moisture for mixing shall be determined in accordance with IS: 2720 (Part-8) after replacing the aggregate fraction retained on 22.4 mm sieve with material of 4.75 mm to 22.4 mm size. While adding water, due allowance should be made for evaporation losses.

However, at the time of compaction, water in the wet mix should not vary from the optimum value by more than agreed limits. The mixed material should be uniformly wet and no segregation should be permitted.

Spreading of Mix:-Immediately after mixing, the aggregates shall be spread uniformly and evenly upon the prepared sub-grade/sub-base/base in required quantities. In no case shall these be dumped in heaps directly on the area where these are to be laid nor shall their hauling over a partly completed stretch be permitted. The mix may be spread by a paver finisher. The paver finisher shall be self-propelled of adequate capacity with following features:

- (i) Loading hoppers and suitable distribution system, so as to provide a smooth uninterrupted material flow for different layer thicknesses from the tipper to the screed.
- (ii) Hydraulically operated telescopic screed for paving width up to 8.5 m and fixed screed beyond this. The screed shall have tamping and vibrating arrangement for initial compaction of the layer.
- (iii) Automatic levelling control system with electronic sensing device to maintain mat thickness and cross slope of mat during laying procedure. In exceptional cases where it is not possible for the paver to be utilized, mechanical means like motor grader may be used with the prior approval of the Engineer. The motor grader shall be capable of spreading the material uniformly all over the surface. The surface of the aggregate shall be carefully checked with templates and all high or low spots remedied by removing or adding aggregate as may be required. The layer may be tested by depth blocks during construction. No segregation of larger and fine particles should be allowed. The aggregates as spread should be of uniform gradation with no pockets of fine materials.

The Engineer may permit manual mixing and laying of wet mix macadam where small quantity of wet mix macadam is to be executed. Manual mixing/laying in inaccessible/ remote locations and in situations where use of machinery is not feasible can also be permitted. Where manual mixing/laying is intended to be used, the same shall be done with the approval of the Engineer.

11.10.1.3. Compaction:-After the mix has been laid to the required thickness, grade and cross fall/camber the same shall be uniformly compacted to the full depth with suitable roller. If the thickness of single compacted layer does not exceed 100 mm, a smooth wheel roller of 80 to 100kN weight may be used. For a compacted single layer up to 200 mm, the compaction shall be done with the help of

vibratory roller of minimum static weight of 80 to 100 kN with an arrangement for adjusting the frequency and amplitude. An appropriate frequency and amplitude may be selected. The speed of the roller shall not exceed 5 km/h. In portions having unidirectional cross fall/super elevation, rolling shall commence from the lower edge and progress gradually towards the upper edge. Thereafter, roller should progress parallel to the center line of the road, uniformly over-lapping each preceding track by at least one-third width until the entire surface has been rolled. Alternate trips of the roller shall be terminated in stops at least 1 m away from any preceding stop. In portions in camber, rolling should begin at the edge with the roller running forward and backward until the edges have been firmly compacted. The roller shall then progress gradually towards the center parallel to the center line of the road uniformly overlapping each of the preceding track by at least one-third width until the entire surface has been rolled. Any displacement occurring as a result of reversing of the direction of a roller or from any other cause shall be corrected at once as specified and/or removed and made good.

Along forms, kerbs, walls or other places not accessible to the roller, the mixture shall be thoroughly compacted with mechanical tampers or a plate compactor. Skin patching of an area without scarifying the surface to permit proper bonding of the added material shall not be permitted. Rolling should not be done when the sub-grade is soft or yielding or when it causes a wavelike motion in the sub-base/base course or sub-grade. If irregularities develop during rolling which exceed 12 mm when tested with a 3 m straight edge, the surface should be loosened and premixed material added or removed as required before rolling again so as to achieve a uniform surface conforming to the desired grade and crossfall. In no case shall the use of unmixed material be permitted to make up the depressions. Rolling shall be continued till the density achieved is at least 98 percent of the maximum dry density for the material as determined by the method outlined in IS:2720 (Part-8). After completion, the surface of any finished layer shall be well-closed, free from movement under compaction equipment or any compaction planes, ridges, cracks and loose material. All loose, segregated or otherwise defective areas shall be made good to the full thickness of the layer and re-compacted.

11.10.1.4. Arrangement for Traffic:-During the period of construction, arrangements for traffic shall be done as per Clause 112.

11.10.1.5. Setting and drying:-After final compaction of wet mix macadam course, the road shall be allowed to dry for 24 hours.

11.10.1.6. Opening to Traffic:

No vehicular traffic shall be allowed on the finished wet mix macadam surface. Construction equipment may be allowed with the approval of the Engineer.

11.11. Surface Finish and Quality Control of Work

11.11.1. Surface Evenness

The surface finish of construction shall conform to the requirements of Clause 902.

11.11.2. Quality Control

Control on the quality of materials and works shall be exercised by the Engineer in accordance with Section 900.

Rectification of Surface Irregularity:-Where the surface irregularity of the wet mix macadam course exceeds the permissible tolerances or where the course is otherwise defective due to sub-grade soil getting

mixed with the aggregates, the full thickness of the layer shall be scarified over the affected area, re-shaped with added premixed material or removed and replaced with fresh premixed material as applicable and re-compacted in accordance with Clause 406.3. The area treated in the aforesaid manner shall not be less than 5 m long and 2 m wide. In no case shall depressions be filled up with unmixed and ungraded material or fines.

Measurements for Payment:-Wet mix macadam shall be measured as finished work in position in cubic meters.

Rate:-The Contract unit rate for wet mix macadam shall be payment in full for carrying out the required operations including full compensation for all components listed in Clause 401.7.

11.12. CEMENT CONCRETE KERB AND KERB WITH CHANNEL

11.12.1. **Scope:**-This work shall consist of constructing cement concrete kerbs and kerbs with channel in the central median and/or along the footpaths or separators in conformity with the lines, levels and dimensions as specified in the drawings or as directed by the Engineer.

11.12.2. **Materials:**-Kerbs and kerbs with channel shall be provided in cement concrete of Grade M 20 in accordance with Section 1700 of these Specifications.

11.12.3. **Type of Construction:**-These shall be cast-in-situ construction with suitable kerb casting machine in all situations except at locations where continuous casting with equipment is not practicable. In those locations precast concrete blocks shall be used.

11.12.4. **Equipment:**-A continuous kerbs casting equipment of adequate capacity and controls, capable of laying the kerbs in required cross-sections and producing a well-compacted mass of concrete free of voids and honeycombs, shall be used.

11.12.5. Construction Operations

11.12.5.1. Kerbs shall be laid on firm foundation of granular layer of pavement; it shall be fixed with bounding of bituminous crust and median field materials.

11.12.5.2. In the median portions in the straight reaches, the kerbs shall be cast in continuous lengths. In the portions where footpath is provided and/or the slope of the carriageway is towards median (as in case of super elevated portion), there shall be sufficient gap/recess left in the kerbs to facilitate drainage openings.

11.12.5.3. After laying the kerbs and just prior to hardening of the concrete, saw cut grooves shall be provided at 5 m intervals up to finished road level or as specified by the Engineer.

11.12.5.4. Kerbs on the drainage ends such as along the footpath or the median in super elevated portions, shall be cast with monolithic concrete channels as indicated in drawings. The slope of the channel towards drainage pipes shall be ensured for efficient drainage of the road surface.

11.12.5.5. Vertical and horizontal tolerances with respect to true line and level shall be ± 6 mm.

11.12.6. **Measurements for Payment:**-Cement concrete kerbs with channel including foundation shall be measured in linear meter for the complete item of work.

11.12.7. **Rate:**-The Contract unit rates for cement concrete kerbs with channel including foundation for kerbs shall be payment in full compensation for furnishing all materials, labour, tools, equipment for

construction and other incidental cost necessary to complete the work.

11.13. FOOTPATHS AND SEPARATORS

11.13.1. **Scope:-**The work shall consist of constructing footpaths and/or separators at locations as specified in the drawings or as directed by the Engineer. The lines, levels and dimensions shall be as per the drawings. The scope of the work shall include provision of all drainage arrangements as shown in the drawings or as directed by the Engineer.

11.13.2. **Materials:-**The footpaths and separators shall be constructed with any of the following types:

- (a) Cast-in-situ cement concrete of Grade M 20 as per Section 1700 of the Specifications. The minimum size of the panels shall be as specified in the drawings.
- (b) Precast cement concrete blocks and interlocking blocks/tiles of grade not less than M 30 as per Section 1700 of the Specifications. The thickness and size of the cement concrete blocks or interlocking blocks/ tiles shall be as specified in the drawings.
- (c) Natural stone slab cut and dressed from stone of good and sound quality, uniform in texture, free from defects and at least equal to a sample submitted by the Contractor and approved by the Engineer. The thickness and size of the natural stone slab shall be as specified in the drawings.

11.13.3. Construction Operations

11.13.3.1. Drainage pipes below the footpath originating from the kerbs shall be first laid in the required slope and connected to the drains/sumps/storm water drain/drainage chutes as per provisions of the drawings, or as specified.

11.13.3.2. Portion on back side of kerbs shall be filled and compacted with granular sub-base material as per Clause 401 of the Specifications in specified thickness.

11.13.3.3. The base for cast-in-situ cement concrete panels/ tiles/ nature stone slab shall be prepared and finished to the required lines, levels and dimensions as indicated in the drawings.

Over the prepared base, precast concrete interlocking blocks/tiles/natural stone slabs and/or cast-in- situ slab shall be set/laid as described in Clauses 410.3.4 and 410.3.5.,

11.13.3.4. **Tiles/Natural Stone Slabs:-**The blocks/tiles/slabs shall be set on a layer of average 12 thick cement-sand mortar (1:3) laid on prepared base in such a way that there is no rocking. The gaps between the blocks/tiles/slabs shall not be more than 12 mm and shall be filled with cement-sand mortar (1:3).

11.13.3.5. **Cast-in-Situ Cement Concrete:-**The panels of specified size shall be cast on the prepared base in panels of specified size in a staggered manner. Construction joints shall be provided as per Section 1700 of the Specifications.

11.13.3.6. **Precast Concrete Blocks and Interlocking Concrete Block Pavements** the precast concrete blocks and interlocking concrete block pavement shall be laid on a Bedding of sand of thickness specified in the drawing. The grading of the sand layer shall be as in Table 400-16 in Morth 5th revision Section 400 (Page No.145). The joints shall be filled with sand passing a 2.35 mm size with the grading as in Table 400-17 in Morth 5th revision Section 400 (Page No.145). The bedding sand slightly moist, the moisture content being about 4 percent. The bedding sand shall be compacted by vibratory plate compactor. The blocks shall be laid to the levels indicated on the drawings and to the pattern directed by the Engineer. The surface tolerance shall be ± 10 mm with respect to the

design level. The blocks shall be embedded using a hammer.

11.13.4. **Measurements for Payment:**-Footpaths and separators shall be measured in Sq.m between inside of kerbs. The edge restraint block and kerbs shall be measured separately in linear meter. The items pertaining to drainage shall be measured separately.

11.13.5. **Rate:** Contract unit rates shall be inclusive of full compensation for all labour, materials, tools, equipment for footpaths including the base. Cost of providing pipes and arrangement for their discharge into appropriate drainage channels shall be incidental to the construction of footpaths.

12.1. PRIME COAT, TACT COAT, DENSE BITUMINOUS MACADAM AND BITUMINOUS CONCRETE (Morth 5th Revision Section-500)

12.2. GENERAL REQUIREMENTS FOR BITUMINOUS PAVEMENT LAYERS

12.2.1. **General:**-Bituminous pavement courses shall be made using the materials described in the Specifications. The use of machinery and equipment mentioned in various Clauses of these Specifications is mandatory. Details of the machinery and equipment are available in the Manual for Construction and Supervision of Bituminous Works. The equipment mandatory for any particular project shall be in accordance with the Contract Specifications for that project.

12.2.2. Materials

12.2.2.1. **Binder:**-The binder shall be an appropriate type of bituminous material complying with the relevant Indian Standard, as defined in the appropriate Clauses of these Specifications, or as otherwise specified herein. The choice of binder shall be stipulated in the Contract or by the Engineer. Where viscosity grades of bitumen are specified, they are referred to by a designation in accordance with IS: 73. Where modified bitumen is specified, it shall conform to the requirements of IRC: SP: 53 and IS: 15462; and the following provision of this Specification shall apply.

- (i) Modified bitumen from refinery sources or blended at approved central plant or at site using appropriate industrial process and plant with high shear mill, and testing facilities to achieve stable and homogenous mix shall be used. The use of high shear mixer or any other device capable of producing a homogeneous blend is essential when the modifier is in powder form.
- (ii) Separation, difference in softening point (R&B), shall not be more than 3°C for any type of specified modified bitumen when tested as per Annex B of IS: 15462. Selection criteria for viscosity grade bitumen, based on highest and lowest daily mean temperatures at a particular site, are given in Table 500-1. Selection criteria for modified bitumen shall be in accordance with IRC: SP:53. 501.2.2 Coarse Aggregates

12.2.2.2. The coarse aggregates shall consist of crushed rock, crushed gravel or other hard material retained on the 2.36 mm sieve. They shall be clean, hard, and durable, of cubical shape, free from dust and soft or friable matter, organic or other deleterious matter. Where the Contractor's selected source of aggregates has poor affinity for bitumen, the Contractor shall demonstrate through test results that with the use of anti-stripping agents, the stripping value is improved to satisfy the specification requirements. The Engineer may approve such a source and, as a condition for the approval of that source, the bitumen shall be treated with approved antistripping agents, as per the manufacturer's recommendations, at the cost of the Contractor. Where crushed gravel is proposed for use as aggregate not less than 90 percent by weight of the crushed material retained on the 4.75 mm sieve shall have at least two fractured faces, except that in the case of bituminous concrete the requirement in this regard shall be 95 percent. The aggregates shall satisfy the physical requirements set forth in the individual relevant clause for the material.

12.2.2.3. **Fine Aggregates:**-Fine aggregates shall consist of crushed or naturally occurring material, or a combination of the two, passing 2.36 mm sieve and retained on the 75 micron sieve. They shall be clean, hard, durable, dry and free from dust, and soft or friable matter, organic or other deleterious matter. Natural sand shall not be allowed in binder and wearing courses. However, natural sand upto 50 percent of the fine aggregates may be allowed in base courses. Fine aggregates shall have a sand equivalent value of not less than 50 when tested in accordance with the requirement of IS: 2720 (Part 37). The plasticity index of the fraction passing 0.425 mm shall not exceed 4 when tested in accordance with IS: 2720 (Part 5). The fine aggregates shall satisfy the

physical requirements set forth in the individual relevant-clause for the material in question.

12.2.2.4. Sources of Material:-The sources of materials proposed to be used by the Contractor shall be tested to the satisfaction of the Engineer who shall give the necessary approval. The Engineer may from time to time withdraw approval of a specific source, or attach conditions to the existing approval. Any change in aggregate source for bituminous mixes shall require a new mix design, and laying trials, where the mix is based on a job mix design. Stockpiles from different sources approved or otherwise, shall be kept separate, such that there is no contamination between one material and another. Each source submitted for approval shall contain material sufficient for at least 5 days' work.

12.2.3. Mixing:-Pre-mixed bituminous materials shall be prepared in a hot mix plant of adequate capacity and capable of yielding a mix of proper and uniform quality with thoroughly coated aggregates.

Appropriate mixing temperatures are given in Table 500-2 of these Specifications. The difference in temperature between the binder and aggregate shall at no time exceed 14°C. In order to ensure uniform quality of the mix and better coating of aggregates, the hot mix plant shall be calibrated from time to time. The essential features of the hot mix plants are given in Annex A of IRC: 27. Table 500-2: Mixing, Laying and Roiling Temperatures for Bituminous Mixes (Degree Celsius) in Morth 5th revision section 500 (Page No.151).

If a continuous type mixing plant is used, the Contractor must demonstrate by laboratory analysis that the cold feed combined grading is within the grading limits specified for that bituminous bound material. In the case of a designed job mix, the bitumen and filler content shall be derived using this combined grading.

12.2.4. Transporting:-Bituminous materials shall be transported in clean insulated and covered vehicles. An asphalt release agent, such as soap or lime water, may be applied to the interior of the vehicle to prevent sticking and to facilitate discharge of the material.

12.2.5. Laying

12.2.5.1. Weather and Seasonal Limitations:-Laying shall be suspended:

- (i) In presence of standing water on the surface;
- (ii) When rain is imminent, and during rains, fog or dust storm;
- (iii) When the base/binder course is damp;
- (iv) When the air temperature on the surface on which it is to be laid is less than 10°C for mixes with conventional bitumen and is less than 15°C for mixes with modified bitumen;
- (v) When the wind speed at any temperature exceeds the 40 km per hour at 2 m height.

12.2.5.2. Cleaning of Surface:-The surface on which the bituminous work is to be laid shall be cleaned of all loose and extraneous matter by means of a mechanical broom and air jet. The equipment for applying a high-pressure air jet from a compressor to remove dust or loose matter shall be available full time at the site.

12.2.5.3. Spreading:-Prior to spreading the mix, the base shall be prepared by carrying out the required operations as per Clause 501.8 depending upon the site conditions. Except in areas where paver cannot get access, bituminous materials shall be spread, levelled and tamped by an approved self-propelled paving machine equipped with an electronic sensing device. The essential features of the paver finisher shall conform to Annex A of IRC:27. As soon as possible after arrival at site, the materials shall be supplied continuously to the paver and laid without delay. The rate of delivery

of material to the paver shall be regulated to enable the paver to operate continuously. The travel rate of the paver, and its method of operations, shall be adjusted to ensure an even and uniform flow of bituminous material across the screed, free from dragging, tearing and segregation of the material. In areas with restricted space (such as confined space, foot ways, of irregular shape and varying thickness, approaches to expansion joints, etc.) where paver cannot be used, the material shall be spread, raked and levelled with suitable hand tools by trained staff.

The minimum thickness of material laid in each paver pass shall be in accordance with the minimum values given in the relevant parts of these Specifications. When laying binder course or wearing course approaching an expansion joint of a structure, machine laying shall stop 300 mm short of the joint. The remainder of the pavement up to the joint, and the corresponding area beyond it, shall be laid by hand, and the joint or joint cavity shall be kept clear of surfacing material.

Bituminous material, with a temperature greater than 145°C, shall not be laid or deposited on bridge deck water-proofing systems, unless precautions against heat damage have been approved by the Engineer.

12.2.5.4. Cleanliness and Overlaying

Bituminous material shall be kept clean and uncontaminated. The only traffic permitted to run on bituminous material to be overlaid shall be that engaged in laying and compacting the next course or, where a binder course is to be sealed or surface dressed, that engaged on such surface treatment. Should any bituminous material become contaminated, the Contractor shall make it good to the satisfaction of the Engineer, in compliance with Clause 501.8. Binder course material shall be covered by either the wearing course or surface treatment, whichever is specified in the Contract.

12.2.6. Compaction:-Bituminous materials shall be laid and compacted in layers, which enable the specified thickness, surface level, regularity requirements and compaction to be achieved. Compaction of bituminous materials shall commence as soon as possible after laying. Compaction shall be substantially completed before the temperature falls below the minimum rolling temperatures stated in the relevant part of these Specifications. Rolling of the longitudinal joints shall be done immediately behind the paving operation. After this, rolling shall commence at the edges and progress towards the center longitudinally except that on super-elevated and unidirectional cambered portions, it shall progress from the lower to the upper edge parallel to the center line of the pavement. Rolling shall continue until all roller marks have been removed from the surface. All deficiencies in the surface after laying shall be made good by the attendants behind the paver, before initial rolling is commenced. The initial or breakdown rolling shall be done with 8-10 tonne static weight smooth-wheel rollers. The intermediate rolling shall be done with 8-10 tonne static weight or vibratory roller or with a pneumatic tyred roller of 12 to 15 tonne weight, with a tyred pressure of at least 0.56 MPa. The Contractor shall demonstrate the efficiency of the equipment proposed to be used by carrying compaction trials. The procedure for site trials shall be submitted to the Engineer for approval. The finish rolling shall be done with 6 to 8 tonne smooth wheel tandem rollers. Rolling shall continue until the specified compaction is achieved.

Where compaction is to be determined by density of cores, the requirements to prove the performance of rollers shall apply in order to demonstrate that the specified density can be achieved. In such cases the Contractor shall specify the plant, and the method by which he intends to achieve the specified level of compaction and finish at temperatures above the minimum specified rolling temperature. Laying trials shall then demonstrate the acceptability of the plant and method used. Bituminous materials shall be rolled in a longitudinal direction, with the driven rolls nearest the paver. The roller shall first compact material adjacent to joints and then work from the lower to the upper side of the layer, overlapping on successive

passes by at least one-third of the width of the rear roll or, in the case of a pneumatic-tyred roller, at least the nominal width of 300 mm. In portions with super-elevated and unidirectional camber, after the edge has been rolled, the roller shall progress from the lower to the upper edge. Rollers should move at a speed of not more than 5 km per hour. The roller shall not be permitted to stand on pavement which has not been fully compacted, and necessary precautions shall be taken to prevent dropping of oil, grease, petrol, Diesel or other foreign matter on the pavement either when the rollers are operating or standing. The wheels of roller machine shall be in good working order, to prevent the mix from adhering to the wheels. Only sufficient moisture to prevent adhesion between the wheels of rollers and the mix should be used. Surplus water shall not be allowed to stand on the partially compacted pavement.

12.2.7. Joints

12.2.7.1. Where joints are made, the material shall be fully compacted and the joint made flush in one of the following ways:

- (a) All joints shall be cut vertical to the full thickness of the previously laid mix. All loosened material shall be discarded and the vertical face coated with a suitable viscosity grade hot bitumen, or cold applied emulsified bitumen. While spreading the material along the joint the material spread shall overlap 25 mm to 50 mm on the previously laid mix beyond the vertical face of the joint. The thickness of the loose overlap material should be approximately a quarter more than the final compacted thickness. The overlapped mix shall be dragged back to the hot lane so that the roller can press the small excess into the hot side of the joint to obtain a high joint density.
- (b) By using two or more pavers operating in echelon, where this is practicable and in sufficient proximity for adjacent widths to be fully compacted by continuous rolling.

12.2.7.2. All longitudinal joints shall be offset at least 300 mm from parallel joints in the layer beneath or as directed, and in a layout approved by the Engineer. Joints in the wearing course shall coincide with either the lane edge or the lane marking, whichever is appropriate. Longitudinal joints shall not be situated in wheel track zones.

12.2.7.3. For transverse joints method a) above shall apply. Transverse joints in the successive and adjoining layers shall have a minimum offset of 2 m.

12.2.7.4. Construction Operations

12.2.7.4.1. Preparing Existing Granular Surface:-Where the existing surface is granular, all loose materials shall be removed, and the surface lightly watered where the profile corrective course to be provided as a separate layer is also granular. Where the profile corrective course of bituminous material is to be laid over the existing granular surface, the latter shall, after removal of all loose material, be primed in accordance with Clause 502 and a tack coat applied in accordance with Clause 503. The surface of all granular layers on which bituminous works are to be placed, shall be free from dust. All such layers must be capable of being swept, after the removal of any non-integral loose material, by means of a mechanical broom, without shedding significant quantities of material and dust removed by air jet, washing, or other means approved by the Engineer. After cleaning, the surface shall be correct to line and level within the tolerances specified for base course.

12.2.7.4.2. Scarifying Existing Bituminous Surface: - Where specified or shown on the drawings, the existing bituminous layer in the specified width shall be removed with care and without causing undue disturbance to the underlying layer, by a suitable method approved by the Engineer. After removal of all loose and disintegrated material, the underlying layers which might have been

disturbed shall be suitably reworked supplementing the base material as necessary with suitable fresh stone aggregates and compacted to line and level. The compacted finished surface shall be primed in accordance with Clause 502. Reusable materials shall be stacked as directed by the Engineer with all leads and lifts.

12.3. PRIME COAT OVER GRANULAR BASE

12.3.1. Scope:-This work shall consist of the application of a single coat of low viscosity liquid bituminous material to a porous granular surface preparatory to the superimposition of bituminous treatment or mix. The work shall be carried out on a previously prepared granular/ stabilized surface to Clause 501.8.

12.3.2. Materials

12.3.2.1. The primer shall be cationic bitumen emulsion RS1 grade conforming to IS:8887 or medium curing cutback bitumen conforming to IS:217 or as specified in the Contract.

12.3.2.2. Quantity of RS 1 grade bitumen emulsion for various types of granular surface shall be as given in Table 500-3 in Morth 5th revision Section-500 (Page No.166).

12.3.2.3. Cutback for primer shall not be prepared at the site. Type and quantity of cutback bitumen for various types of granular surface shall be as given in Table 500-4 in in Morth 5th revision Section-500 (Page No.166).

12.3.2.4. The correct quantity of primer shall be decided by the Engineer and shall be such that it can be absorbed by the surface without causing run-off of excessive primer and to achieve desired penetration of about 8-10 mm.

12.3.3. Weather and Seasonal Limitations:-Primer shall not be applied during a dust storm or when the weather is foggy, rainy or windy or when the temperature in the shade is less than 1 OOC. Cutback bitumen as primer shall not be applied to a wet surface. Surfaces which are to receive emulsion primer should be damp, but no free or standing water shall be present. Surface can be just wet by very light sprinkling of water.

12.3.4. Construction

12.3.4.1. Equipment:-The primer shall be applied by a self-propelled or towed bitumen pressure sprayer equipped for spraying the material uniformly at specified rates and temperatures. Hand spraying shall not be allowed except in small areas, inaccessible to the distributor, or in narrow strips where primer shall be sprayed with a pressure hand sprayer, or as directed by the Engineer.

12.3.4.2. Preparation of Road Surface:-The granular surface to be primed shall be swept clean by power brooms or mechanical sweepers and made free from dust. All loose material and other foreign material shall be removed completely. If soil/ moorum binder has been used in the WBM surface, part of this should be brushed and removed to a depth of about 2 mm so as to achieve good penetration.

12.3.4.3. Application of Bituminous Primer:- After preparation of the road surface as per Clause 502.4.2, the primer shall be sprayed uniformly at the specified rate. The method for application of the primer will depend on the type of equipment to be used, size of nozzles, pressure at the spray bar and speed of forward movement. The Contractor shall demonstrate at a spraying trial, that the equipment and method to be used is capable of producing a uniform spray, within the tolerances

specified. No heating or dilution of SS1 bitumen emulsion and shall be permitted at site. Temperature of cutback bitumen shall be high enough to permit the primer to be sprayed effectively though the jets of the spray and to cover the surface uniformly.

12.3.4.4. Curing of Primer and Opening to Traffic:- A primed surface shall be allowed to cure for at least 24 hours or such other higher period as is found to be necessary to allow all the moisture/volatiles to evaporate before any subsequent surface treatment or mix is laid. Any unabsorbed primer shall first be blotted with a light application of sand, using the minimum quantity possible. A primed surface shall not be opened to traffic other than that necessary to lay the next course.

12.3.5. Quality Control of Work:-For control of the quality of materials and the works carried out, the relevant provisions of Section 900 shall apply. 502.6 Arrangements for Traffic During construction operations, arrangements for traffic shall be made in accordance with the provisions of Clause 112.

12.3.6. Measurement for Payment: - Prime coat shall be measured in terms of surface area of application in square metres.

12.3.7. Rate:-The contract unit rate for prime coat shall be payment in full for carrying out the required operations including full compensation for all components listed in Clause 401.7 (i) to and as applicable to the work specified in these Specifications. Payment shall be made on the basis of the provision of prime coat at an application rate of quantity at 0.6 kg per square metre or at the rate specified in the Contract, with adjustment, plus or minus, for the variation between this quantity and the actual quantity approved by the Engineer after the preliminary trials referred to in Clause 502.4.3.

12.4. TACK COAT

12.4.1. Scope:-The work shall consist of the application of a single coat of low viscosity liquid bituminous material to existing bituminous, cement concrete or primed granular surface preparatory to the superimposition of a bituminous mix, when specified in the Contract or as instructed by the Engineer. The work shall be carried out on a previously prepared surface in accordance with Clause 501.8.

12.4.2. Materials:- The binder used for tack coat shall be either Cationic bitumen emulsion (RS 1) complying with IS:8887 or suitable low viscosity paving bitumen of VG 10 grade conforming to IS:73. The use of cutback bitumen RC:70 as per IS:217 shall be restricted only for sites at sub-zero temperatures or for emergency applications as directed by the Engineer. The type and grade of binder for tack coat shall be as specified in the Contract or as directed by the Engineer.

12.4.3. Weather and Seasonal Limitations: - Bituminous material shall not be applied during a dust storm or when the weather is foggy, rainy or windy or when the temperature in the shade is less than 10°C. Where the tack coat. Consists of emulsion, the surface shall be slightly damp, but not wet. Where the tack coat is of cutback bitumen, the surface shall be dry.

12.4.4. Construction

12.4.4.1. Equipment

A self-propelled or towed bitumen pressure sprayer, equipped for spraying the material uniformly at a specified rate, shall apply the tack coat. Hand spraying shall not be permitted except in small areas, inaccessible to the distributor, or narrow strips,

12.5. MEASUREMENT

- 12.5.1. **Preparation of Base:-**The surface on which the tack coat is to be applied shall be clean and free from dust, dirt, and any extraneous material, and be otherwise prepared in accordance with the requirements of Clauses 501.B. The granular or stabilized surfaces shall be primed as per Clause 502. Immediately before the application of the tack coat, the surface shall be swept clean with a mechanical broom, and high pressure air jet, or by other means as directed by the Engineer.
- 12.5.2. **Application of Tack Coat:-**The application of tack coat shall be at the rate specified in Table 500-5, and it shall be applied uniformly. If rate of application of Tack Coat is not specified in the contract, then it shall be the rate specified in Table 500-5. No dilution or heating at site of RS1 bitumen emulsion shall be permitted. Paving bitumen if used for tack coat shall be heated to appropriate temperature in bitumen boilers to achieve viscosity less than 2 poise. The normal range of spraying temperature for a bituminous emulsion shall be 20°C to 70°C and for cutback, 50°C to 80°C. The method of application of tack coat will depend on the type of equipment to be used, size of nozzles, pressure at the spray bar, and speed or forward movement. The Contractor shall demonstrate at a spraying trial, that the equipment and method to be used is capable of producing a uniform spray, within the tolerances specified. Table 500-5: Rate of Application of Tack Coat in Morth 5th revision Section-500 (Page No.169).
- 12.5.3. **Curing of Tack Coat: -** The tack coat shall be left to cure until all the volatiles have evaporated before any subsequent construction is started. No plant or vehicles shall be allowed on the tack coat other than those essential for the construction.
- 12.5.4. **Quality Control of Work: -** For control of the quality of materials and the works carried out, the relevant provisions of Section 900 shall apply.
- 12.5.5. **Arrangements for Traffic:-**During the period of construction, arrangements for traffic shall be made in accordance with the provisions of Clause 112.
- 12.5.6. **Measurement for Payment:-**Tack coat shall be measured in terms of surface area of application in square meters.
- 12.5.7. **Rate:-**The contract unit rate for tack coat shall be payment in full for carrying out the required operations including for all components listed in Clause 401.8 (i) to (v) and as applicable to the work specified in these Specifications. The rate shall cover the provision of tack coat, at 0.2 kg per square meter or at the rate specified in the Contract, with the provision that the variation between this quantity and actual quantity of bitumen used will be assessed and the payment adjusted accordingly.

12.6. DENSE BITUMINOUS MACADAM

- 12.6.1. **Scope:-**The specification describes the design and construction procedure for Dense Bituminous Macadam, (DBM), and the work shall consist of construction in a single or multiple layers of DBM on a previously prepared base or sub-base. The thickness of shall be 85 mm or as per drawing and mentioned in contract agreement. The thickness of a single layer shall be 50 mm to 100 mm.

12.6.2. Materials

- 12.6.2.1. **Bitumen:-**The bitumen shall be viscosity grade (VG-30) paving bitumen complying with the Indian Standard Specification IS: 73, modified bitumen complying with Clause 501.2.1 or as otherwise specified in the Contract. The type and grade of bitumen to be used shall be specified in the Contract.

- 12.6.2.2. **Course Aggregates:-**The coarse aggregates shall consist of crushed rock, crushed gravel or other

hard material retained on 2.36 mm sieve. They shall be clean, hard, and durable, of cubical shape, free from dust and soft or friable matter, organic or other deleterious substances. Where the Contractor's selected source of aggregates has poor affinity for bitumen, the Contractor shall produce test results that with the use of anti-stripping agents, the stripping value is improved to satisfy the specification requirements. The Engineer may approve such a source and as a condition for the approval of that source, the bitumen shall be treated with an approved anti-stripping agent, as per the manufacturer's recommendations, at the cost of the Contractor.

The aggregates shall satisfy the requirements specified in Table 500-8. Where crushed gravel is proposed for use as aggregate, not less than 90 percent by weight of the crushed material retained on the 4.75 mm sieve shall have at least two fractured faces.

12.6.2.3. Fine Aggregates:-Fine aggregates shall consist of crushed or naturally occurring mineral material, or a combination of the two, passing the 2.36 mm sieve and retained on the 75-micron sieve. These shall be clean, hard, durable, dry and free from dust, and soft or friable matter, organic or other deleterious matter. Natural sand shall not be allowed in binder courses. However, natural sand up to 50 percent of the fine aggregate may be allowed in base courses. The fine aggregate shall have a sand equivalent value of not less than 50 when tested in accordance with the requirement of IS: 2720 (Part 37). The plasticity index of the fraction passing the 0.425 mm sieve shall not exceed 4, when tested in accordance with IS: 2720 (Part 5). 5.4.2.4 Filler:-Filter shall consist of finely divided mineral matter such as rock dust, hydrated lime or cement approved by the Engineer. The filler shall be graded within the limits indicated in Table 500-9. The filler shall be free from organic impurities and have a plasticity Index not greater than 4. The Plasticity Index requirement shall not apply if filler is cement or lime. Where the aggregates fail to meet the requirements of the water sensitivity test in Table 500-8, then 2 percent by total weight of aggregate, of hydrated lime shall be used and percentage of fine aggregate reduced accordingly.

12.6.2.4. Aggregate Grading and Binder Content

12.6.2.4.1. When tested in accordance with IS: 2386 Part 1 (wet sieving method), the combined grading of the coarse and fine aggregates and filler for the particular mixture shall fall within the limits given in Table 500-10 for grading 1 or 2 as specified in the Contract. To avoid gap grading, the combined aggregate gradation shall not vary from the lower limit on one sieve to higher limit on the adjacent sieve. Table 500-8 : Physical Requirements for Coarse Aggregate for Dense Bituminous Macadam in Morth 5th revision in section-500 (Page No.176).

12.6.3. Construction Operations

12.6.3.1. Weather and Seasonal Limitations:-The provisions of Clause 501.5.1 shall apply.

12.6.3.2. Preparation of Base: The base on which Dense Graded Bituminous Material is to be laid shall be prepared in accordance with Clauses 501 and 902 as appropriate, or as directed by the Engineer.

12.6.3.3. Stress Absorbing Layer: Where a stress absorbing layer is specified in the Contract, this shall be applied in accordance with the requirements of Clause 517.

12.6.3.4. Prime Coat: Where the material on which the dense bituminous macadam is to be laid is other than a bitumen bound layer, a prime coat shall be applied, as specified, in accordance with the provisions of Clause 502, or as directed by the Engineer.

12.6.3.5. Tack Coat: Where the material on which the dense bituminous macadam is to be laid is either bitumen bound layer or primed granular layer, tack coat shall be applied, as specified, in accordance

with the provisions of Clause 503, or as directed by the Engineer.

12.6.3.6. Mixing and Transportation of the Mix: The provisions as specified in Clauses 501.3 and 501.4 shall apply. Table 500-2 gives the mixing, laying and rolling temperature for dense mixes using viscosity grade bitumen. In case of modified bitumen, the temperature of mixing and compaction shall be higher than the mix with viscosity grade bitumen. The exact temperature depends upon the type and amount of modifier used and shall be adopted as per the recommendations of the manufacturer. In order to have uniform quality, the plant shall be calibrated from time to time.

12.6.3.7. Spreading: The provisions of Clauses 501.5.3 and 501.5.4(Morth 5th revision) shall apply.

12.6.3.8. Rolling: The general provisions of Clauses 501.6 and 501.7 shall apply, as modified by the approved laying trials. The compaction process shall be carried out by the same plant, and using the same method, as approved in the laying trials, which may be varied only with the express approval of the Engineer in writing.

12.6.4. Opening to Traffic: It shall be ensured that the traffic is not allowed without the approval of the Engineer in writing, on the surface until the dense bituminous layer has cooled to the ambient temperature.

12.6.5. Surface Finish and Quality Control of Work: The surface finish of the completed construction shall conform to the requirements of Clause 902. All materials and workmanship shall comply with the provisions set out in Section 900 of these Specifications.

12.6.6. Arrangements for Traffic: During the period of construction, arrangements for traffic shall be made in accordance with the provisions of Clause 112.

12.6.7. Measurement for Payment: Dense Graded Bituminous Materials shall be measured as finished work either in cubic meters, tonnes or by the square meter at a specified thickness as indicated in the Contract drawings, or documents, or as otherwise directed by the Engineer.

12.6.8. Rate: The contract unit rate for Dense Graded Bituminous Macadam shall be payment in full for carrying out all the required operations as specified and shall include, to all components listed in Clause 501.8.8.2. The rate shall include the provision of bitumen, at 4 percent and 4.5 percent by weight of the total mixture for grading 1 and grading 2 respectively. The variation in actual percentage of bitumen used shall be assessed and the payment adjusted plus or minus accordingly.

12.7. BITUMINOUS CONCRETE

12.7.1. Scope:-This work shall consist of construction of Bituminous Concrete, for use in wearing and profile corrective courses. This work shall consist of construction in a single layer of bituminous concrete on a previously prepared bituminous bound surface. A single layer shall be 30 mm/40 mm/50 mm thick.

12.7.2. Materials

12.7.2.1. Bitumen:-The bitumen shall conform to Clause 504.2.1.

12.7.2.2. Course Aggregates: The coarse aggregates shall be generally as specified in Clause 504.2.2, except that the aggregates shall satisfy the physical requirements of Table 500-16 and where crushed gravel is proposed for use as aggregate, not less than 95 percent by weight of the crushed material retained on the 4.75 mm sieve shall have at least two fractured faces. Table 500-16: Physical Requirements for Coarse Aggregate for Bituminous Concrete in Morth 5th revision in

Section 500 (Page No.188).

12.7.2.3. Fine Aggregates: The fine aggregates shall be all as specified in Clause 505.2.3 (Morth 5th revision).

12.7.2.4. Filler: Filler shall be as specified in Clause 505.2.4.

12.8. Aggregate Grading and Binder Content:

12.8.1. When tested in accordance with IS: 2386 Part 1 (Wet grading method), the combined grading of the coarse and fine aggregates and filler shall fall within the limits shown in Table 500-17. The grading shall be as specified in the Contract. Table 500-17: Composition of Bituminous Concrete Pavement Layers in Morth 5th revision in Section 500 (Page No.189).

12.8.2. Construction Operations

12.8.2.1.1. **Weather and Seasonal Limitations:** The provisions of Clause 501.5.1 shall apply.

12.8.2.1.2. **Preparation of Base:** The surface on which the bituminous concrete is to be laid shall be prepared in accordance with Clauses 501 and 902 as appropriate, or as directed by the Engineer. The surface shall be thoroughly swept clean by mechanical broom and dust removed by compressed air. In locations where a mechanical broom cannot get access, other approved methods shall be used as directed by the Engineer.

12.8.2.1.3. **Geo-synthetics:** Where Geo-synthetics are specified in the Contract, this shall be in accordance with the requirements stated in Clause 703.

12.8.2.1.4. **Stress Absorbing Layer:** Where a stress-absorbing layer is specified in the Contract, this shall be applied in accordance with the requirements of Clause 517.

12.8.2.1.5. **Tack Coat:** The provisions as specified in Clause 504.4.6 shall apply.

12.8.2.1.6. **Mixing and Transportation of the Mix:** The provisions as specified in Clauses 501.3, 501.4 and 504.4.7(Morth 5th) shall apply.

12.8.2.1.7. **Spreading:-**The general provisions of Clauses 501.6 and 501.7 shall apply, as modified by the approved laying trials.

12.8.2.1.8. **Rolling:-**The general provisions of Clauses 501.6 and 501.7 shall apply, as modified by the approved laying trials.

12.8.2.1.9. **Opening to Traffic:-**Provisions in Clause 504.5 shall apply.

12.8.2.1.10. **Surface Finish and Quality Control:-**The surface finish of the completed construction shall conform to the requirements of Clause 902. All materials and workmanship shall comply with the provisions set out in Section 900 of these Specifications.

12.8.3. **Arrangements for Traffic:** During the period of construction, arrangements for traffic shall be made in accordance with the provisions of Clause 112.

12.8.4. Measurement for Payment The measurement shall be as specified in Clause 505.S.

12.8.5. **Rate:** The contract unit rate shall be all as specified in Clause 504.9, except that the rate shall include the provision of bitumen at 5.2 percent & 5.4 percent for grading 1 and grading 2 by weight

of total mix respectively. The variation in actual percentage of bitumen used will be assessed and the payment adjusted plus and minus accordingly.

13.1. CONCRETE PAVEMENT (Morth 5th Revision Section-600)

13.2. 6.1 DRY LEAN CEMENT CONCRETE SUB-BASE

13.2.1. Scope:

13.2.1.1. The work shall consist of construction of (zero slump) dry lean concrete sub-base for cement concrete pavement in accordance with the requirements of these Specifications and in conformity with the lines, grades and cross-sections shown on the drawings or as directed by the Engineer. The work shall include furnishing of all plant and equipment, materials and labour and performing all operations, in connection with the work, as approved by the Engineer.

13.2.1.2. The design parameters of dry lean concrete sub-base, viz., width, thickness, grade of concrete, details of joints, if any, etc. shall be as stipulated in the drawings.

13.2.2. Materials

13.2.2.1. Sources of Materials

The Contractor shall indicate to the Engineer the source of all materials with relevant test data to be used in the dry lean concrete work sufficiently in advance and the approval of the Engineer for the same shall be obtained at least 45 days before the scheduled commencement of the work in trial length. If the Contractor later proposes to obtain the materials from a different source during the execution of main work, he shall notify the Engineer with relevant test data for his approval at least 45 days before such materials are to be used.

13.2.2.2. Cement

Ordinary Portland Cement 43 Grade and 53 Grade conforming to IS: 8112 to be used. Cement to be used may preferably be obtained in bulk form. It shall be stored in accordance with stipulations contained in Clause 1014 and shall be subjected to acceptance test prior to its immediate use. The brand of cement shall be approved from Engineer prior to commence the work.

13.2.2.3. Aggregates

13.2.2.3.1. Aggregates for lean concrete shall be natural material complying with IS:383. The aggregates shall not be alkali reactive. The limits of deleterious materials shall not exceed the requirements set forth in Table 600-2.

13.2.2.3.2. Coarse Aggregates

Coarse aggregates shall comply with Clause 602.2.6.2, except that the maximum size of the coarse aggregate shall be 26.5 mm, and aggregate gradation shall comply with Table 600-1(Refer Morth 5th Revision).

13.2.2.3.3. Fine Aggregates

The fine aggregate shall comply with Clause 602.2.6.3.

13.2.2.4. Water

Water used for mixing and curing of concrete shall comply with Clause 602.2.7.

13.2.2.5. Storage of Materials

All materials shall be stored in accordance with the provisions of Clauses 602.2.12 of these Specifications and other relevant IS Specifications.

13.2.3. Proportioning of Materials for the Mix

13.2.3.1. The mix shall be proportioned with a maximum aggregate cementitious material ratio of 15:1. The water content shall be adjusted to the optimum as per Clause 601.3.2 for facilitating compaction by rolling. The strength and density requirements of concrete shall be determined in accordance with Clauses 601.7 and 601.8 by making trial mixes. Care should be taken to prevent one size of aggregate falling into the other size of the hopper of the feeding bin while loading the individual size of aggregates into the bins.

13.2.3.2. Moisture Content

The optimum water content shall be determined and demonstrated by rolling during trial length construction and the optimum moisture content and degree of compaction shall be got approved from Engineer. While laying in the main work, the lean concrete shall have a moisture content between the optimum and optimum +2 percent, keeping in view the effectiveness of compaction achieved and to compensate for evaporation losses.

13.2.3.3. Cement Content

The cement content in the dry lean concrete shall be such that the strength specified in Clause 601.3.4 is achieved. The minimum cement content shall be 150 kg/cu.m of concrete. If this minimum is not sufficient to produce dry lean concrete of the specified strength, it shall be increased as necessary by the Contractor at his own cost.

13.2.3.4. Concrete Strength

The average compressive strength of each consecutive group of 5 cubes made in accordance with Clause 903.5.1.1 shall not be less than 10 MPa at 7 days. In addition, the minimum compressive strength of any individual cube shall not be less than 7.5 MPa at 7 days. The design mix complying with the above Clauses shall be got approved from the Engineer and demonstrated in the trial length construction.

13.2.4. Sub-grade

The sub-grade shall conform to the grades and cross-sections shown on the drawings and shall be laid and compacted in accordance with Clause 305. The subgrade strength shall correspond to the design strength specified in the Contract. As far as possible, the construction traffic shall be avoided on the prepared sub-grade.

13.2.5. Drainage Layer

A drainage layer conforming to Clause 401 shall be laid above the subgrade before laying the DryLean Concrete sub-base, as specified in the drawings and the Contract.

13.2.6. Construction

13.2.6.1. General

The Dry Lean Concrete shall be laid on the prepared granular drainage layer. The Dry Lean Concrete sub-base shall be overlaid with concrete pavement only after 7 days of sub-base construction.

13.2.6.2. Batching and Mixing

The batching plant shall be capable of proportioning the materials by weight, each type of material being weighed separately in accordance with Clauses 602.9.2, 602.9.3.1 and 602.9.3.2.

The design features of Batching Plant should be such that the plant can be shifted quickly.

13.2.6.3. Transporting

Plant mix lean concrete shall be discharged immediately from the mixer, transported directly to the point where it is to be laid and protected from the weather by covering the tipping trucks with tarpaulin during transit. The concrete shall be transported by tipping trucks, sufficient in number to ensure a continuous supply of material to feed the laying equipment to work at a uniform speed and in an uninterrupted manner. The lead of the batching plant to paving site shall be such that the travel time available from mixing to paving as specified in Clause 601.6.5.2 will be adhered to. Tipping truck shall not have old concrete sticking to it. Each tipping truck shall be washed with water jet before next loading as and when required after inspection.

13.2.6.4. Placing

Lean concrete shall be placed by a paver with electronic sensor on the drainage layer or as specified in the Contract. The equipment shall be capable of laying the material in one layer in an even manner without segregation, so that after compaction the total thickness is as specified. The paving machine shall have high amplitude tamping bars to give good initial compaction to the sub-base. One day before placing of the dry lean cement concrete sub-base, the surface of the granular sub-base/drainage layer shall be given a fine spray of water and rolled with a smooth wheeled roller.

Preferably the lean concrete shall be placed and compacted across the full width of the , two lane carriageway, by constructing it in one go. In roads with carriageway more than 2 lanes a longitudinal joint shall be provided. Transverse butt type joint shall be provided at the end of the construction in a day. Transverse joints in the concrete pavement shall not be coterminous with the transverse construction joint of the Dry Lean Concrete.

The Dry Lean Concrete shall be laid in such a way that it is at least 750 mm wider on each side than the proposed width including paved shoulders of the concrete pavement. The actual widening shall be decided based on the specifications of the paver, such that the crawler moves on the Dry Lean Concrete, and the cost of extra width shall be borne by the Contractor.

13.2.6.5. Compaction

13.2.6.5.1. The compaction shall be carried out immediately after the material is laid and levelled. In order to ensure thorough compaction, rolling shall be continued on the full width till there is no further visible movement under the roller and the surface is well closed. The minimum dry density obtained shall not be less than 98 percent of that achieved during the trial length construction in accordance with Clause 601.7. The densities achieved at the edges i.e. 0.5 m from the edge shall not be less than 96 percent of that achieved during the trial construction.

13.2.6.5.2. The spreading, compacting and finishing of the lean concrete shall be carried out as rapidly as possible and the operation shall be so arranged as to ensure that the time between the mixing of the first batch of concrete in any transverse section of the layer and the final finishing of the same shall not exceed 90 minutes when the temperature of concrete is between 25oC and 30oC, and 120 minutes if less than 25oC'. This period may be reviewed by the Engineer in the light of

the results of the trial run but in no case shall it exceed 120 minutes. Work shall not proceed when the temperature of the concrete exceeds 30°C. If necessary, chilled water or addition of ice may be resorted to for bringing down the temperature. It is desirable to stop concreting when the ambient temperature is above 35°C. After compaction has been completed, roller shall not stand on the compacted surface for the duration of the curing period except during commencement of next day's work near the location where work was terminated the previous day.

13.2.6.5.3. Double drum smooth-wheeled vibratory rollers of "minimum 80 to 100 kN static weight are suitable for rolling dry lean concrete. In case any other roller is proposed, the same shall be got approved from the Engineer, after demonstrating its performance. The number of passes required to obtain maximum compaction depends on the thickness of the dry lean concrete, the compatibility of the mix and the weight and type of the roller and the same as well as the total requirement of rollers for the jobs shall be determined during trial run by measuring in-situ density and the scale of the work to be undertaken.

Except on super elevated portions where rolling shall proceed from the inner edge to the outer, rolling shall begin from the edges gradually progressing towards the centre. First, the edge/edges shall be compacted with a roller running forward and backward. The roller shall then move inward parallel to the centreline of the road, in successive passes uniformly lapping preceding tracks by at least one half width.

13.2.6.5.4. A preliminary pass without vibration to bed the Dry Lean Concrete down shall be given followed by the required number of passes to achieve the desired density and final pass without vibration to remove roller with vibration marks and to smoothen the surface.

Special care and attention shall be exercised during compaction near joints, kerbs, channels, side forms and around gullies and manholes. In case adequate compaction is not achieved by tie roller at these locations, use of plate vibrators shall be made, if so directed by the Engineer.

13.2.6.5.5. The final lean concrete surface on completion of compaction shall be well closed, free from movement under roller and free from ridges, low spots, cracks, loose material, pot holes, ruts or other defects. The final surface shall be inspected immediately on completion and all loose, segregated or defective areas shall be corrected by using fresh lean concrete material, laid and compacted. For repairing honeycombed/hungry surface, concrete with aggregates of size 10 mm and below shall be spread and compacted as per Specifications. It is necessary to check the level of the rolled surface for compliance. Any level/thickness deficiency shall be corrected after applying concrete with aggregates of size 10 mm and below after roughening the surface. Surface regularity also shall be checked with 3 m straight edge. Strength tests shall be carried out, and if deficiency in strength is noticed, at least three (evenly spread) cores of minimum 100 mm dia per km shall be cut to check deficiency in strength. The holes resulting from cores shall be restored by filling with concrete of the specified strength and compacted by adequate rodding.

13.2.6.5.6. Segregation of concrete in the tipping trucks shall be controlled by moving the dumper back and forth while discharging the mix into the same or by any appropriate means. Paving operation shall be such that the mix does not segregate.

13.2.6.6. Joints

Construction and longitudinal joints shall be provided as per the drawings.

Transverse butt type joint shall be provided at the end of the construction in a day. Longitudinal construction joint shall be provided only when full width paving is not possible. Transverse joints in Dry

Lean concrete shall be staggered from the construction butt type joint in Concrete pavement by 800-1000 mm.

Longitudinal joint in Dry Lean Concrete shall be staggered by 300-400 mm from the longitudinal joint of concrete pavement.

At longitudinal or transverse construction joints, unless vertical forms are used, the edge of compacted material shall be cut back to a vertical plane where the correct thickness of the properly compacted material has been obtained.

13.2.6.7. Curing

As soon as the lean concrete surface is compacted, curing shall commence. One of the following methods shall be adopted:

- (a) Curing may be done by covering the surface by gunny bags/hessian, which shall be kept wet continuously for 7 days by sprinkling water.
- (b) The curing shall be done by spraying with approved resin based aluminized reflective curing compound conforming to ASTM'-C 309-81 in accordance with Clause 602.9.12. As soon as the curing compound has lost its tackiness, the surface shall be covered with wet hessian for three days. The rate of application shall be as recommended by the supplier.
- (c) Wax-based white pigmented curing compound with water retention index of not less than 90 percent shall be used to cure the dry lean concrete. The curing compound shall conform to BS:7542. The compound shall be applied uniformly with a mechanical sprayer and with a hood to protect the spray from the wind. The curing compound shall be applied over the entire exposed surface of the Dry Lean Concrete, including sides and edges, at the rate of 0.2 litres / sq.m, or as recommended by the supplier.

The first application, referred to as curing application shall be applied immediately after the final rolling of Dry Lean Concrete is completed. As soon as the curing compound loses tackiness, the surface shall be covered with wet hessian for three days. The second application of curing compound also referred to as the demanding application, shall be applied 24 to 48 hours prior to the placement of the concrete pavement. Any damaged Dry Lean Concrete shall be corrected prior to the second application. Normally, the manufacturer's instructions shall be followed for its application.

13.2.7. Trial Mixes

The Contractor shall make trial mixes of dry lean concrete with moisture contents like 5.0, 5.5,6.0, 6.5 and 7.0 percent using specified cement content, specified aggregate grading and aggregate-cement ratio specified in Clause 601.3.1. Optimum moisture and density shall be established by preparing cubes with varying moisture contents. Compaction of the mix shall be done in three layers with vibratory hammer fitted with a square or rectangular foot as described in Clause 903.5.1.1. After establishing the optimum moisture, a set of six cubes shall be cast at optimum moisture for the determination of compressive strength on the third and the seventh day. Trial mixes shall be repeated if the strength is not satisfactory by increasing cement content. After the mix design is approved, the Contractor shall construct a trial section in accordance with Clause 601.8.

If during the construction of the trial length, the optimum moisture content determined as above is found to be unsatisfactory, the Contractor may make suitable changes in the moisture content to achieve the satisfactory mix. The cube specimens prepared with the changed mix content should satisfy the strength requirement. Before production of the mix, natural moisture content of the aggregate should be determined

on a day-to-day basis so that the moisture content could be adjusted. The mix finally designed should neither stick to the rollers nor become too dry resulting in raveling of surface.

13.2.8. Trial Length

13.2.8.1. The trial length shall be constructed at least 14 days in advance of the proposed date of commencement of work. At least 30 days prior to the construction of the trial length, the Contractor shall submit for the Engineer's approval a "Method Statement" giving detailed description of the proposed materials, plant, equipment, mix proportions, and procedure for batching, mixing, laying, compaction and other construction procedures. The Engineer shall also approve the location and length of trial construction which shall be a minimum of 100 m length laid in two days and for full width of the pavement.

13.2.8.2. After the construction of the trial length, the in-situ density of the freshly laid material shall be determined by sand replacement method. Three density holes shall be made at locations equally spaced along a diagonal that bisects the trial length and average of these densities shall be determined. The density holes shall not be made in the strip 500 mm from the edges. The average density obtained from the three samples collected shall be the reference density and is considered as 100 percent. The field density of regular work will be compared with this reference density in accordance with Clauses 601.6.5.1 and 903.5.1.2.

13.2.8.3. The hardened concrete shall be cut over 3 m width and reversed to inspect the bottom surface for any segregation taking place. The trial length shall be constructed after making necessary changes in the gradation of the mix to eliminate segregation of the mix. The lower surface shall not have honey-combing and the aggregates shall not be held loosely at the edges

13.2.8.4. The main work shall not start until the trial length has been approved by the Engineer. After approval has been given, the materials, mix proportions, moisture content, mixing, laying, compaction plant and construction procedures shall not be changed without the approval of the Engineer.

13.2.9. Tolerances for Surface Regularity, Level, Thickness, Density and Strength

Control of quality of materials and works shall be exercised by the Engineer in accordance with Section 900.

13.2.10. Traffic

No heavy commercial vehicles like trucks and buses shall be permitted on the dry lean concrete sub-base. Construction vehicles at slow speed may be permitted after 7 days of its construction with the prior approval of the Engineer.

13.2.11. Measurement for Payment

The unit of measurement for dry lean concrete pavement shall be in cubic metro of concrete placed, based on the net plan area for the accepted thickness shown on the drawings or as directed by the Engineer.

13.2.12. Rate

The Contract unit rate payable for dry lean concrete sub-base shall be for carrying out the required operations including full compensation for all labour, materials and equipment, mixing, transport, placing, compacting, finishing, curing, rectification of defective surface testing and incidentals such as trial length

to complete the work as per Specifications, all royalties, fees, storage and rents where necessary and all leads and lifts.

13.3. CEMENT CONCRETE PAVEMENT

13.3.1. Scope

13.3.1.1. The work shall consist of construction of un-reinforced, dowel jointed, plain Conant concrete pavement in accordance with the requirements of these Specifications and in uniformity with the lines, grades and cross sections shown on the drawings. The work shall include furnishing of all plant and equipment, materials and labour and performing all operations in connection with the work, as approved by the Engineer.

13.3.1.2. The design parameters, viz., thickness of pavement slab, grade of concrete, joint details etc. shall be as stipulated in the drawings.

13.3.2. Materials

13.3.2.1. Source of Materials

The Contractor shall indicate to the Engineer the source of all materials to be used in the 'concrete work with relevant test data sufficiently in advance, and the approval of the Engineer for the same shall be obtained at least 45 days before the scheduled commencement of the work in trial length. If the Contractor subsequently proposes to obtain materials from a different source during the execution of main work, he shall notify the Engineer, with relevant test cats, for his approval, at least 45 days before such materials are to be used.

13.3.2.2. Cement

Ordinary Portland Cement 43 Grade and 53 Grade confirming to IS: 8112 to be used. Cement to be used may preferably be obtained in bulk form. It shall be stored in accordance with stipulations contained in Clause 1014 and shall be subjected to acceptance test prior to its immediate use. The brand of cement shall be approved from Engineer prior to commence the work. The cement shall be subjected to acceptance test.

13.3.2.3. Chemical Admixtures

Admixtures conforming to IS:9103 and IS:6925 shall be permitted to improve workability of the concrete and/or extension of setting time, on satisfactory evidence that they will not have any adverse effect on the properties of concrete with respect to strength, volume change, durability and have no deleterious effect on steel bars. The particulars of the admixture and the quantity to be used, must be furnished to the Engineer in advance to obtain his approval before use. Satisfactory performance of the admixtures should be proved both on the laboratory concrete trial mixes and in the trial length paving. If air entraining admixture is used, the total quantity of air shall be 5t1.5 percent for 31.5 mm maximum nominal size aggregate (in air-entrained concrete as a percentage of the volume of the mix).

13.3.2.4. Silica Fumes

Silica fume conforming to a standard approved by the Engineer may be used as an admixture in the proportion of 3 to 10 percent of cement. Silica fume shall comply with the requirements given in IS:15388-2003, IS:456-2000, IRC:SP:76 and IRC:44-2008.

13.3.2.5. Fibres

Fibres may be used subject to the provision in the design/approval by the Engineer to reduce the shrinkage cracking and post-cracking. The fibres may be steel fibre as per IRC:SP:46 or polymeric Synthetic fibres within the following range of specifications:

Effective Diameter	10 micron – 100 micron
Length	6-48 mm
Specific gravity	More than 1.0
Suggested Dosage	0.6-2.0 kg/cu.m (0.2-0.6% by weight of cement in mix) Usage will be regulated as stipulated in IRC:44/IS:456
Water absorption	Less than 0.45 percent
Melting point of this fibre shall not be less than 160°C	
The aspect ratio generally varies from 200 to 2000.	
These synthetic fibres will have good alkali and UV light resistance.	

When fibres are used, the mix shall be so designed that the slump of concrete at paving site is 25±15 mm.

13.3.2.6. Aggregates

13.3.2.6.1. Aggregates for pavement concrete shall be natural material complying with IS:383 but with a Los Angeles Abrasion Test value not exceeding 35 percent. The limits of deleterious materials shall not exceed the requirements set out in Table 600-2 (Refer Morth 5th Revision).

The aggregates shall be free from chert, flint, chalcedony or other silica in a form that can react with the alkalis in the cement. In addition, the total chlorides content expressed as chloride ion content shall not exceed 0.06 percent by weight and the total sulphate content expressed as sulphuric anhydride (SO₃) shall not exceed 0.25 percent by weight. In case the Engineer considers that the aggregates are not free from dirt, the same may be washed and drained for at least 72 hours before batching, as directed by the Engineer.

13.3.2.6.2. Coarse Aggregates

Coarse aggregates shall consist of clean, hard, strong, dense, non-porous and durable pieces of crushed stone or crushed gravel and shall be devoid of pieces of disintegrated stone, soft, flaky, elongated, very angular or splintery pieces. The maximum size of coarse aggregate shall not exceed 31.5 mm for pavement concrete. No aggregate which has water absorption more than 2 percent shall be used in the concrete mix. The aggregates shall be tested for soundness in accordance with IS:2386 (Part-5). After 5 cycles of testing, the loss shall not be more than 12 percent if sodium sulphate solution is used or 18 percent if magnesium sulphate solution is used. The Los Angeles Abrasion value shall not exceed 35. The combined flakiness and elongation index of aggregate shall not be more than 35 percent.

13.3.2.6.3. Fine Aggregates

The fine aggregates shall consist of clean natural sand or crushed stone sand or a combination of the two and shall conform to IS:383. Fine aggregate shall be free from soft particles, clay, shale, loam, cemented particles, mica and organic and other foreign matter. The fine aggregates shall have a sand equivalent value of not less than 50 when tested in accordance with the requirement of IS:2720 (Part 37).

13.3.2.6.4. Combined Gradation of Fine and Coarse Aggregates

The combined gradation of fine and coarse, aggregates shall be as per Table 600-3 (Morth 5th revision).

13.3.2.7. Water

Water used for mixing and curing of concrete shall be clean and free from injurious amount of oil, salt, acid, vegetable matter or other substances harmful to the finished concrete. It shall meet with the requirements stipulated in IS:456.

13.3.2.8. Steel for Dowels and Tie Bars

Steel shall conform to the requirements of IS:432 and IS:1786 as relevant. The dowel bars shall conform to IS:432 of Grade I. Tie bars shall be either High yield Strength Deformed bars conforming to IS:1786 and grade of Fe 500 or plain bars conforming to IS:432 of Grade I. The steel shall be coated with epoxy paint for protection against corrosion.

13.3.2.9. Joint Filler Board

Synthetic Joint filler board for expansion joints shall be used only at abutting structures like bridges and shall be of 20-25 mm thickness within a tolerance of ± 1.5 mm and of a firm compressible material and complying with the requirements of IS:1838, with a compressibility more than 25 percent. It shall be 25 mm less in depth than the thickness of the slab within a tolerance of ± 3 mm and provided to the full width between the side forms. It shall be in suitable lengths which shall not be less than one lane width. If two pieces are joined to make up fullwidth, the joint shall be taped such that no slurry escapes through the joint. Holes to accommodate dowel bars shall be accurately bored or punched out to give a sliding fit on the dowel bars.

13.3.2.10. Joint Sealing Compound

The joint sealing compound shall be of hot poured, elastomeric type or cold polysulphidel polyurethane/silicone type having flexibility, resistance to age hardening and durability as per IRC:57. Manufacturer's certificate shall be produced by the Contractor for establishing that the sealant is not more than six months old and stating that the sealant complies with the relevant standard mentioned below. The samples shall meet the requirements as mentioned in IRC:57.

If sealant is of hot poured type, it shall conform to

Hot applied sealant : IS:1834 or ASTM : 3406-95, as applicable

Cold poured sealants shall be one of the following :

- | | |
|------------------|--------------------------------------|
| i) polysulphide | IS:11433 (Part I), BS:5212 (Part II) |
| ii) polyurethane | BS:5212 |
| iii) silicone | ASTM 5893-04 |

13.3.2.11. Preformed Seals

The pre-formed joint sealing material shall be a vulcanized elastomeric compound using polychloroprene (Neoprene) as the base polymer.

The joint seal shall conform to requirements of ASTM D 2628 as given in Table 600-4 (Refer Morth 5th Revision).

13.3.2.12. Storage of Materials

All materials shall be stored in accordance with the provisions of Clause 1014 of the Specifications. All efforts shall be made to store the materials in proper places so as to prevent their deterioration or contamination by foreign matter and to ensure their satisfactory quality and fitness for the work. The platform where aggregates are stock piled shall be paved and elevated from the ground atleast by 150 mm. The area shall have slope to drain off rain water. The storage space must also permit easy inspection, removal and storage of the materials. Aggregates of different sizes shall be stored in partitioned stack-yards. All such materials even though stored in approved godowns must be subjected to acceptance test as per Clause 903 of these Specifications prior to their use.

13.3.3. Proportioning of Concrete

13.3.3.1. After approval by the Engineer of all the materials to be used in the concrete, the Contractor shall submit the mix design based on weighed proportions of all ingredients for the approval of the Engineer vide Clause 602.3.4. The mix design shall be submitted at least 30 days prior to the paving of trial length and the design shall be based on laboratory trial mixes using the approved materials and methods as per IRC:44 or IS:10262. The target mean strength for the design mix shall be determined as indicated in Clause 602.3.3.1. The mix design shall be based on the flexural strength of concrete.

13.3.3.2. Cement Content

Ordinary Portland Cement (OPC) shall be used and the quantity of cement shall not be less than 400kg/cu.m. If this minimum cement content is not sufficient to produce concrete of the specified strength, it,shall be increased as necessary by the contractor at his own cost.

13.3.3.3. Concrete Strength

13.3.3.3.1. The characteristic flexural strength of concrete shall not be less than 4.5 MPa unless specified otherwise. Target mean flexural strength for mix design shall be more than $4.5 \text{ MPa} + 1.65s$, where s is standard deviation of flexural strength derived by conducting test on minimum 30 beams. While designing the mix in the laboratory, correlation between flexural and compressive strengths of concrete shall be established on the basis of at least thirty tests on specimens. However, quality control in the field shall be exercised on the basis of flexural strength. It may, however, be ensured that the materials and mix proportions remain substantially unaltered during the daily concrete production. The water content shall be the minimum required to provide the agreed workability for full compaction of the concrete to the required density as determined by the trial mixes or as approved by the Engineer and the maximum free water cement ratio shall be 0.45 when only OPC is used and 0.50 when blended cement (Portland Pozzolana Cement or Portland Slag Cement or OPC blended with fly ash or Ground Granulated Blast Furnance Slag, at site) is used.

13.3.3.3.2. The ratio between the 7 and 28 day strength shall be established for the mix to be used in the slab in advance, by testing pairs of beams and cubes at each stage on at that six batches of trial mix. The average strength of the 7 day cured specimens shall be calculate by the average strength of the 28 day specimens for each batch, and the ratio 'R' to be determined. The ratio 'R' shall be expressed to three decimal places.

If during the construction of the trial length or during some normal working, the average value of any four consecutive 7 day test results falls below the required 7 day strength as derived from the value of 'R' then the cement content of the concrete shall, without extra payment, be increased by 5 percent by weight or by an amount agreed by the Engineer. The increased cement content shall be maintained at least until the four

corresponding 28 day strengths have been assessed for in conformity with the requirements as per Clause 602.3.3.1. Whenever the cement content is increased, the concrete mix shall be adjusted to maintain the required workability.

13.3.3.4. Workability

13.3.3.4.1. The workability of the concrete at the point of placing shall be adequate for the concrete to be fully compacted and finished without undue flow. The optimum workability for the mix to suit the paving plant being used shall be determined by the Contractor and approved by the Engineer. The control of workability in the field shall be exercised by the slump test as per IS:1199.

13.3.3.4.2. The workability requirement at the batching and mixing plant and paving site shall be established by slump tests carried during trial paving. These requirements shall be established from season to season and also when the lead from batching and mixing plant Site to the paving site changes. The workability shall be established for the type of paving equipment available. A slump value in the range of 25 * 15 mm is reasonable for paving works but this may be modified depending upon the site requirement and got approved by the Engineer. These tests shall be carried out on every tipping truck/dumper at batching and mixing plant site and paving site initially when the work commences but subsequently the frequency can be reduced to alternate tipping trucks or as per the instructions of the Engineer.

13.3.3.5. Design Mix

13.3.3.5.1. The Contractor shall carry out laboratory trials of design mix with the materials from the approved sources to be used as per IRC:44. Trial mixes shall be made in presence of the Engineer or his representative and the design mix shall be subject to the approval of the Engineer. They shall be repeated, if necessary, until the proportions, that will produce a concrete which complies in all respects with these Specifications, and conform to the requirements of the design/drawings.

13.3.3.5.2. The proportions determined as a result of the laboratory trial mixes may be adjusted, if necessary, during the construction of the trial length. Thereafter, neither the materials nor the mix proportions shall be varied in any way except with the written approval of the Engineer.

13.3.3.5.3. Any change in the source of materials or mix proportions proposed by the Contractor during the course of work shall be assessed by making laboratory trial mixes and the construction of a further trial length of length not less than 50 m unless approval is given by the Engineer for minor adjustments like compensation for moisture content in aggregates or minor fluctuations in the grading of aggregate.

13.3.4. Sub-base

The cement concrete pavement shall be laid over the sub-base constructed in accordance with the relevant drawings and Specifications. It shall be ensured that the sub-base is not damaged before laying the concrete pavement. If the dry lean concrete sub-base is found damaged at some places or it has cracks wider than 10 mm, it shall be repaired with fine cement concrete (aggregate size 10 mm and down) or bituminous concrete before laying separation membrane layer.

13.3.5. Separation Membrane

A separation membrane shall be used between the concrete slab and the sub-base. Separation membrane shall be impermeable PVC sheet 125 micron thick transparent or white in colour laid flat with minimum

creases. Before placing the separation membrane, the sub-base shall be swept clean of all the extraneous materials using air compressor. Wherever overlap of plastic sheets is necessary, the same shall be at least 300 mm and any damaged sheathing shall be replaced at the Contractor's cost. The separation membrane may be nailed to the lower layer with concrete nails. The separation membrane shall be omitted when two layers of wax-based curing compound is used.

13.3.6. Joints

13.3.6.1. The locations and type of joints shall be as shown in the drawing. Joints shall be constructed depending upon their functional requirement. The location of the joints should be transferred accurately at the site and mechanical saw cutting of joints done as per stipulated dimensions. It shall be ensured that the required depth of cut is made from edge-to-edge of the pavement. Transverse and longitudinal joints in the pavement and Dry Lean Concrete sub-base shall be staggered so that they are not coincident vertically and are at least 800 to 1000 mm and 300 to 400 mm apart respectively. Sawing of joints shall be carried out with diamond studded blades soon after the concrete has hardened to take the load of the sawing machine and crew members without damaging the texture of the pavement.

Sawing operation could start as early as 4-8 hours after laying of concrete pavement but not later than 8 to 12 hours depending upon the ambient temperature, wind velocity, relative humidity and required maturity of concrete achieved for this purpose.

When the kerb is cast integrally with the main pavement slab, the joint cutting shall also be extended to the kerb.

Where the use of maturity meter is specified, sawing should not be initiated when the compressive strength of the concrete is less than 2 MPa and should be completed before it attains the compressive strength of 7 MPa.

13.3.6.2. Transverse Joints

13.3.6.2.1. Transverse joints shall be contraction, construction and expansion joints constructed at the spacing described in the drawings. Transverse joints shall be straight within the following tolerances along the intended line of joints.

- (i) Deviations of the performed filler board (IS:1838) in the case of expansion joints from the intended line of the joint shall not be greater than ± 10 mm.
- (ii) The best fit straight line through the joint grooves as constructed shall be not more than 25 mm from the intended line of the joint.
- (iii) Deviations of the joint groove from the best fit straight line of the joint shall not be greater than 10 mm.
- (iv) Transverse joints on each side of the longitudinal joint shall be in line with each other and of the same type and width. Transverse joints shall have a sealing groove which shall be sealed in compliance with Clause 602.10.

13.3.6.2.2. Contraction Joints

The contraction joints shall be placed transversely at pre-specified locations as per drawings/ design using dowel bars. These joints shall be cut as soon as the concrete has undergone initial hardening and is hard enough to take the load of joint sawing machine without causing damage to the slab.

Contraction joints shall consist of a mechanical sewn joint groove, 3 to 5 mm wide and one-fourth to one-third depth of the slab; 5 mm or as stipulated in the drawings and dowel bars complying with Clause 602.6.5.

Contraction joint shall be widened subsequently to accommodate the sealant as per Clause 602.10, to dimensions shown on drawings or as per IRC:57.

13.3.6.2.3. Expansion Joints

The expansion joint shall consist of a joint filler board complying with Clause 602.2.9 and dowel bars complying with Clause 602.6.5 and as detailed in the drawings. The filler board shall be positioned vertically with the prefabricated joint assemblies along the line of the joint within the tolerances given in Clause 602.6.2.1. The adjacent slabs shall be completely separated from each other by the joint filler board.

13.3.6.3. Transverse Construction Joint

Transverse construction joint shall be placed whenever concreting is completed after a day's work or is suspended for more than 30 minutes. These joints shall be provided at location of contraction joints using dowel bars. If sufficient concrete has not been mixed to form a slab extending up to a contraction joint, and if an interruption occurs, the concrete placed shall be removed up to the last preceding joint and disposed of. At all construction joints, steel bulk heads shall be used to retain the concrete. The surface of the concrete laid subsequently shall conform to the grade and cross sections of the previously laid pavement. When positioning of bulk head/stop-end is not possible, concreting to an additional 1 or 2 m length may be carried out to enable the movement of joint cutting machine so that joint grooves may be cut and the extra 1 or 2 m length is cut out and removed subsequently after concrete has hardened.

After minimum 14 days of curing, in case OPC cement is used and 16 days of curing when flyash or blended cement is used, the construction joint shall be widened to accommodate the sealant as per Clause 602.10 to dimensions shown on drawing or as per IRC:57.

13.3.6.4. Longitudinal Joint

13.3.6.4.1. The longitudinal joints shall be constructed by forming or by sawing as per details of the joints shown in the drawing. Sawed longitudinal joints shall be constructed when the concrete pavement placement width exceeds 4.5 m. The groove may be cut after the final set of the concrete. Joints should be sawn to at least one-third the depth of the slab ± 5 mm as indicated in the drawing. The joint shall be widened subsequently to dimensions shown on the drawings.

Where adjacent lanes of pavement are constructed separately using slip form pavers or side forms, the tie bars may be bent at right angles against the vertical face/ side of the first lane constructed and straightened before placing concrete in the adjacent lane. Broken or damaged tie bars shall be repaired or replaced as required.

The groove for sealant shall be cut in the pavement lane placed later.

13.3.6.4.2. Tie Bars

Tie bars shall be provided at the longitudinal joints as per dimensions and spacing shown in the drawing and in accordance with Clause 602.6.6. The direction of the tie bars at curves shall be radial in the direction of the radius.

13.3.6.5. Dowel Bars

13.3.6.5.1. Dowel bars shall be mild steel rounds in accordance with Clause 602.2.8 with details/dimensions as indicated in the drawings and free from oil, dirt, loose rust or scale. They shall be straight, free of irregularities and burring restricting slippage in the concrete. The sliding ends shall be sawn or cropped cleanly with no protrusions outside the normal diameter of the bar. Any protrusions shall be removed by grinding the ends of the dowel bars. The dowel bar shall be supported on cradles/dowel chairs in pre-fabricated joint assemblies positioned prior to the construction of the slabs or mechanically inserted with vibration into the plastic concrete by a method which ensures correct placement of the bars besides full re-compaction of the concrete around the dowel bars.

13.3.6.5.2. Unless shown otherwise on the drawings, dowel bars shall be positioned at mid depth of the slab within a tolerance of ± 20 mm, and centered equally about intended lines of the joint within a tolerance of ± 25 mm. They shall be aligned parallel to the finished surface of the slab and to the contra line of the carriageway and to each other within tolerances given here-in-under, the compliance of which shall be checked as per Clause 602.11.7.

- (i) For bars supported on cradles prior to the laying of the slab:
 - (a) All bars in a joint shall be within ± 2 mm per 300 mm length of bar
 - (b) 2/3rd of the number of bars shall be within ± 3 mm per 500 mm length of bar
 - (c) No bar shall differ in alignment from an adjoining bar by more than 3 mm per 300 mm length of bar in either the horizontal or vertical plane
 - (d) Cradles supporting dowel bar shall not extend across the line of joint i.e. no steel bar of the cradle assembly shall be continuous across the joint.
- (ii) For all bars inserted after laying of the slab except those inserted by a DowelBarInserter the tolerance for alignment may be twice as indicated in (i) above.

The transverse joints at curves shall be radial in the direction of the radius.

13.2.1.1.1 Dowel bars, supported on cradles in assemblies, when subject to a load of 110 N applied at either end and in either the vertical or horizontal direction (upwards and downwards and in both directions horizontally) shall conform to be within the limits given in Clause 602.6.5.2.

13.2.1.1.2 The assembly of dowel bar and supporting cradles, including the joint filler board in the case of expansion; joints, shall have the following degree of rigidity when fixed in position:-

- (i) For expansion joints, the deflection of the top edge of the filler board shall be not greater than 13 mm, when a load of 1.3 kN is applied perpendicular to the vertical face of the joint filler board and distributed over a length of 600 mm by means of a bar or timber packing, at mid depth and midway between individual fixings, or 300 mm from either end of any length of filler board, if a continuous fixing is used. The residual deflection after load shall be not more than 3 mm.
- (ii) The fixings for joint assembly shall not fail under 1.3 kN load and shall fail before the load reaches 2.6 kN when applied over a length of 600 mm by means of a bar or timber packing placed as near to the level of the line of fixings as practicable.
- (iii) Fixings shall be deemed to fail when there is displacement of the assemblies by more than 3 mm with any form of fixing, under the test load. The displacement shall be measured at the nearest part of the assembly to the contra of the bar or timber packing.

13.2.1.1.3 Dowel bars in the contraction joints, construction joints and expansion joints shall be covered by a thin plastic sheath. The thickness of the sheath shall not exceed 0.5 mm and shall be tightly fitted on the bar for at least two-thirds of the length from one end for dowel bars in

contraction/construction joints and half the length plus 50 mm for expansion joints The sheathed bar shall comply with the following pull-out tests:

Four bars shall be taken at random from stock and without any special preparation shall be covered by sheaths as required in this Clause. The ends of the dowel bars which have been sheathed shall be cast centrally into concrete specimens 150 mm x 150 mm x 600 mm, made of the same mix proportions to be used in the pavement but with a maximum nominal aggregate size of 20 mm and cured in accordance with IS:516. At 7 days a tensile load shall be applied to achieve a movement of the bar of at least 0.25 mm. The average bond stress to achieve this movement shall not be greater than 0.14 MPa.

13.2.1.1.4 For expansion joints, a closely fitting cap 100 mm long consisting of waterproofed cardboard or an approved synthetic material like PVC or GI pipe shall be placed over the sheathed end of each dowel bar. An expansion space (about 25 mm) at least equal in length to the thickness of the joint filler board shall be formed between the end of the cap and the end of the dowel bar by using compressible sponge. To block the entry of cement slurry into the annular space between the sheathing and dowel bar shall be taped around its mouth.

13.2.1.2 Tie Bars

13.2.1.2.1 Tie bars in longitudinal joints shall be deformed steel bars of strength 500 MPa complying with IS:1786 and in accordance with the requirements given in this Clause. The bars shall be free from oil, dirt, loose rust and scale.

13.2.1.2.2 Tie bars projecting across the longitudinal joint shall be protected from corrosion for 75 mm on each side of the joint by a protective coating of bituminous paint with the approval of the Engineer. The coating shall be dry when the tie bars are used. In the case of coastal region and high rainfall areas, tie bars shall be epoxy coated in their full length as per IS:13620.

13.2.1.2.3 Tie bars in longitudinal joints shall be made up into rigid assemblies with adequate supports and fixings to remain firmly in position during the construction of the slab. Alternatively, tie bars at longitudinal joints may be mechanically or manually inserted into the plastic concrete from above by vibration using a method which ensures correct placements of the bars and recompaction of the concrete around the tie bars.

13.2.1.2.4 Tie bars shall be positioned to remain in the middle from the top or within the upper middle third of the slab. depth as indicated in the drawings and approximately parallel to the surface and approximately perpendicular to the line of the joint, with the center of each bar on the intended line of the joint within a tolerance of ± 50 mm, and with a minimum cover of 30 mm below the joint groove. Spacing of tie bars on curves of radius less than 360 m shall not be less than 350 mm.

13.2.1.2.5 To check the position of the tie bars, one metro length, 0.5 m on either side of the longitudinal joint shall be opened when the concrete is green (within 20 to 30 minutes). The pit shall be refilled with the fresh concrete of same mix after checking.

13.2.2 Weather and Seasonal Limitations

13.2.2.1 Concreting during Monsoon Months

Concreting should be avoided during rainy season. However, when concrete is being placed during monsoon months and when it may be expected to rain, sufficient supply of tarpaulin or other waterproof cloth shall be provided along the line of the work. Any time when it rains, all freshly laid concrete which had not been covered for curing purposes shall be adequately protected. Any concrete damaged by rain shall be removed and replaced. If the damage is limited to texture, it shall be retextured in accordance with the directions of the Engineer.

13.2.2.2 Temperature Limitation

No concreting shall be done when the temperature of the concrete reaching the paving site is above 30°C. Besides, in adverse conditions like high temperature, low relative humidity, excessive wind velocity, imminence of rains etc., tents on mobile trusses may be provided over the freshly laid concrete for a minimum period of 3 hours as directed by the Engineer. To bring down the temperature, if necessary, chilled water or ice flakes should be made use of. When the ambient temperature is more than 35°C, no concreting shall be permitted. The ice flakes should not be manufactured from chlorinated water. Generally the rate of evaporation of water shall not exceed 1 kg/sqm/hour as per IRC:15.

No concreting shall be done when the concrete temperature is below 5°C and the temperature is further falling.

13.2.3 Fixed Form Paving

13.2.3.1 Side Forms and Rails

These shall be provided in case of fixed form paving. All side forms shall be of mild steel of depth equal to the thickness of pavement or slightly less to accommodate the surface irregularity of the sub-base. The forms can be placed in series of steel packing plates or shimsto take care of irregularity of sub-base. They shall be sufficiently robust and rigid to support the weight and pressure caused by a paving equipment. Side forms for use with wheeled paving machines shall incorporate metal rails firmly fixed at a constant height below the top of the forms. The forms and rails shall be firmly secured in position by not less than 3 stakes/pins for every 3 m length so as to prevent movement in any direction. Forms and rails shall be straight within a tolerance of 3 mm in 3 m and when in place shall not settle in excess of 1.5 mm in 3 m while paving is being done. Forms shall be cleaned and oiled immediately before each use. The forms shall be bedded on a continuous bed of low moisture content lean cement mortar or concrete and set to the line and levels shown on the drawings within tolerances of 10 mm and 3 mm respectively. The bedding shall not extend under the slab and there shall be no vertical step between adjacent forms of more than 3 mm. The forms shall be got inspected by the Engineer for his approval 12 hours before construction of the slab and shall not be removed until at least 12 hours afterwards. No concreting shall commence till formwork has been approved by the Engineer.

13.2.3.2 At all times sufficient forms shall be used and set to the required alignment for at least 300 m length of pavement immediately in advance of the paving operations, or the anticipated length of pavement to be laid within the next 24 hours whichever is more.

13.2.3.3 Slip Form Paving

13.2.3.3.1 Use of Guidewires

Where slip form paving is proposed, a guidewire shall be provided along both sides of the slab. Each guidewire shall be at a constant height above and parallel to the required edges of the slab as described in the contract drawing within a vertical tolerance of 3 mm. Additionally, one of the wires shall be kept at a constant horizontal distance from the required edge of the pavement as indicated in the contract drawing within a lateral tolerance of ± 10 mm.

13.2.3.3.2 The guidewires shall be supported on stakes 5-6 m apart by connectors capable of fine horizontal and vertical adjustment. The guidewire shall be tensioned on the stakes so that a 500 gm weight shall produce a deflection of not more than 20 mm when suspended at the mid point between any pair of stakes. The ends of the guidewires shall be anchored to fixing point or winch and not on the stakes. On the curves, the stakes shall be fixed at not more than 3 m centre-to-centre.

13.2.3.3.3 The stakes shall be positioned and hammered into the ground and the connectors will be maintained at their correct height and alignment from 12 hours on the day before concreting takes place till after finishing of texturing and spraying of curing compound on the concrete.

However, the guide\ire shall be erected and tensioned on the connectors at any section for at least 2 hours before concreting that section.

13.2.3.4 The Contractor shall submit to the Engineer for his approval of line and level, the stakes and connectors which are ready for use in the length of road to be constructed next day. Such approval shall be obtained at least 12 hours before commencement of paving operation. Any deficiencies noted by the Engineer shall be rectified by the Contractor who shall then re-, for approval of the affected stakes. Work shall not proceed until the Engineer has given his approval. It shall be ensured that the stakes and guide\ires are not affected by the construction equipment when concreting is in progress.

13.2.4 Construction

13.2.4.1 General

A systems approach may be adopted for construction of the pavement, and the Method Statement for carrying out the work, detailing all the activities, indication of time-cycle, equipment personnel etc., shall be got approved from the Engineer before the commencement of the work. This shall include the type, capacity and make of the batching and mixing plant besides the hauling arrangement and paving equipment. The capacity of paving equipment, batching plant as well as all the ancillary equipment shall be adequate for a paving rate of at least 500 m in one day. The paving speed of slip-form paver shall not be less than 1.0 m per minute. The concreting should proceed continuously without stops and starts.

13.2.4.2 Batching and Mixing

Batching and mixing of the concrete shall be done at a central batching and mixing plant with automatic controls, located at a suitable place which takes into account sufficient space for stockpiling of cement, aggregates and stationary water tanks. This shall be located at an approved distance, duly considering the properties of the mix and the transporting arrangements available with the Contractor.

13.2.4.3 Equipment for Proportioning of Materials and Paving

13.2.4.3.1 Proportioning of materials shall be done in the batching plant by weight, each\ type of material being weighed separately. The cement from the bulk stock may be weighed separately from the aggregates. Water shall be measured by volume. Specified percentage of plasticizer in volume will be added by weight of cement. Wherever properly graded aggregate of uniform quality cannot be maintained as envisaged in the mix design, the grading of aggregates shall be controlled by appropriate blending techniques. The capacity of batching and mixing plant shall be at least 25 percent higher than the proposed capacity of the laying/paving equipment.

13.2.4.3.2 Batching Plant and Equipment :

- (1) **General :** The batching plant shall include minimum four bins, weighing hoppers, and scales for the fine aggregates and for each size of coarse aggregate. If cement is used in bulk, a separate scale for cement shall be included. There shall be a separate bin for fly ash, if this additive is specified. The weighing hoppers shall be properly sealed and vented to preclude dust during operation. Approved safety devices shall be provided and maintained for the protection of all personnel engaged in plant operation, inspection and testing. The batch plant shall be equipped with a s:itible non-resettable batch counter which will correctly indicate the number of batches proportioned. A continuous type of mixing plant can also be used provided the ingredients are weighed through electronic sensors before feeding.

- (2) **Automatic weighing devices :** Batching plant shall be equipped to proportion aggregates and bulk cement by means of automatic weighing devices using load cells. The weighing devices shall have an accuracy within *1% in respect of quantity of cement, admixtures and water and i:2% in respect of aggregates and the accuracy shall be checked at least once a month.
- (3) **Mixer :** Mixers shall be pan type, reversible type or any other mixer capable of combining the aggregates, cement, and water into a thoroughly mixed and uniform mass within the specified mixing period, and of discharging the mix, without segregation. Each stationary mixer shall be equipped with an approved timing device which will automatically lock the discharge lever when the drum has been charged and release it at the end of the mixing period. The device shall be equipped with a bell or other suitable warning device adjusted to give a clearly audible signal each time the lock is released. In case of failure of the timing device, the mixer may be used for the balance of the day while it is being repaired, provided that each batch is mixed in 90 seconds or as per the manufacturer's recommendation. The mixer shall be equipped with a suitable non-resettable batch counter which shall correctly indicate the number of batches mixed.

The mixer shall be cleaned at suitable intervals. The pick-up and throw over blades in the drum or drums shall be repaired or replaced when they are worn down 20 mm or more. The Contractor shall (1) have available at the job site a copy of the manufacturer's design, showing dimensions and arrangements of blades in reference to original height and depth, or (2) provide permanent marks on blade to show points of 20 mm wear from new conditions. Drilled holes of 5 mm diameter near each end and at midpoint of each blade are recommended. Batching Plant shall be calibrated in the beginning and thereafter at suitable interval not exceeding 1 month.

- (4) **Control cabin :** An air-conditioned centralized computer control cabin shall be provided for automatic operation of the equipment.
- (5) The design features of the batching plant should be such that it can be shifted quickly.

13.2.4.3.3 Paving Equipment

The concrete shall be placed with an approved fixed form or slip form paver with independent units designed to (i) spread, (ii) consolidate, screed and float-finish, (iii) texture and cure the freshly placed concrete in one complete pass of the machine in such a manner that a minimum of hand finishing will be necessary and so as to provide a dense and homogeneous pavement in conformity with the plans and Specifications. The paver shall be equipped with electronic sensor controls to control the line and grade from either one side or both sides of the machine.

Vibrators shall operate at a frequency of 8000-10000 impulses per minute under load at a maximum spacing of 600 mm. The variable vibration setting shall be provided in the machine.

13.2.4.3.4 Concrete Saw

The Contractor shall provide adequate number of concrete saws with sufficient number of diamond-edge saw blades. The saw machine shall be either electric or petrol/diesel driven type. A water tank with flexible hose and pump shall be made available for this activity on priority basis. The Contractor shall have at least one standby saw in good working condition. The concreting work shall not commence if the saws are not in working condition.

13.2.4.4 Hauling and Placing of Concrete

- 13.2.4.4.1** Freshly mixed concrete from the central batching and mixing plant shall be transported to the paver site by means of tipping trucks or transit mixers of sufficient capacity and approved

design in sufficient numbers to ensure a constant supply of concrete. Covers shall be used for protection of concrete against the weather. While loading the concrete truck shall be moved back and forth under the discharge chute to prevent segregation. The tipping trucks shall be capable of maintaining the mixed concrete in a homogeneous state and discharging the same without segregation and loss of cement slurry. The feeding to the paver is to be regulated in such a way that the paving is done in an uninterrupted manner with uniform speed throughout the day's work. Tipping trucks shall be washed at a regular frequency as prescribed by the Engineer to ensure that no left-over mix of previous loading remains stuck.

13.2.4.4.2 Placing of Concrete

The total time taken from the addition of the water to the mix, until the completion of the surface finishing and texturing shall not exceed 120 minutes when concrete temperature is less than 25°C and 90 minutes when the concrete temperature is between 25°C and 30°C. When the time between mixing and laying exceeds these values, the concrete shall be rejected and removed from the site. Tipping trucks delivering concrete shall normally not run on plastic sheathing nor shall they run on completed slabs until after 28 days of placing the concrete.

The placing of concrete in front of the PQC paver should preferably be from the side placer to avoid damage to DLC by concrete tipping trucks. In case of unavoidable situation, truck supplying concrete to the paver may be allowed to ply on the DLC with the approval of the Engineer. The paver shall be capable of paving the carriageway as shown in the drawings, in a single pass and lift.

13.2.4.4.3 Where fixed form pavers are to be used, forms shall be fixed in advance as per Clause 602.8. Before any paving is done, the site shall be shown to the Engineer, in order to verify the arrangement for paving besides placing of dowels, tie-bars etc., as per the relevant Clauses of these Specifications. The mixing and placing of concrete shall progress only at such a rate as to permit proper finishing, protecting and curing of the concrete in the pavement.

13.2.4.4.4 In areas inaccessible to paving equipment, the pavement shall be constructed using side forms, as per Clause 602.9.7.

13.2.4.4.5 In all cases, the temperature of the concrete shall be measured at the point of discharge from the delivery vehicle.

13.2.4.4.6 The addition of water to the surface of the concrete to facilitate the finishing operations will not be permitted except with the approval of the Engineer when it shall be applied as a mist by means of approved equipment.

13.2.4.4.7 If considered necessary by the Engineer, the paving machines shall be provided with approved covers to protect the surface of the slab under construction from direct sunlight and rain or hot wind.

13.2.4.4.8 While the concrete is still plastic, its surface shall be textured by brush or tines as per the instructions of the engineer in compliance with Clause 602.9.11. The surface and edges of the slab shall be cured by the application of a sprayed liquid curing membrane in compliance with Clause 602.9.12. After the surface texturing, but before the curing compound is applied, the concrete slab shall be marked with the chainage at every 100 m interval by embossing.

13.2.4.4.9 As soon as the side forms are removed, edges of the slabs shall be corrected wherever irregularities have occurred by using fine concrete composed of 1:1:2, cement : sand : coarse aggregate (10 mm down) with water cement ratio not more than 0.4 under the supervision of the Engineer.

13.2.4.4.10 If the requirement of Clause 902.4. for surface regularity fails to be achieved ,on two consecutive working days, then normal working shall cease until the cause of the excessive irregularity has been identified and remedied.

13.2.4.5 Construction by Slip Form Paver

13.2.4.5.1 The slip form paving train shall consist of a power machine which spreads, compacts and finishes the concrete in a continuous operation. The slip form paving machine shall compact the concrete by internal vibration and shape it between the side forms with either a conforming plate or by vibrating and oscillating finishing beams- The concrete shall be deposited without segregation in front of slip form paver across the whole width and to a height which at all times is in excess of the required surcharge. The deposited concrete shall be struck off to the necessary average and differential surcharge by means of the strike off plate or a screw auger device extending across the whole width of the slab. The equipment for striking-off the concrete shall be capable of being rapidly adjusted for changes of the average and differential surcharge necessitated by change in slab thickness or crossfall.

13.2.4.5.2 The level of the conforming plate and finishing beams shall be controlled automatically from the guide wires installed as per Clause 602.8 by sensors attached at the four corners of the slip form paving machine. The alignment of the paver shall be controlled automatically from the guide wire by at least one set of sensors attached to the paver. The alignment and level of ancillary machines for finishing, texturing and curing of the concrete shall be automatically controlled relative to the guide wire or to the surface and edge of the slab.

13.2.4.5.3 Slip-form paving machines shall have vibrators of variable output, with a maximum energy output of not less than 2.5 KW per metro width of slab per 300 mm depth of slab for a laying speed upto 1.5 m per minute. The machines shall be of sufficient mass to provide adequate reaction during spreading and paving operations on the traction units to maintain forward movements during the placing of concrete in all situations. Normal paving speed shall be maintained as per Clause 602.9.1.

13.2.4.5.4 If the edges of the slip formed slab slump to the extent that the surface of the top edge of the slab does not comply with the requirements of Clause 902.3, the work shall be stopped until such time as the Contractor can demonstrate his ability to slip form the edges to the required levels. The deficient edge shall be temporarily supported by a side form and the thickness deficiency shall be made good by adding fresh concrete to the newly formed edge and compacting.

13.2.4.5.5 Slip-form pavers with adequate width to pave the entire carriageway width in one go shall be employed unless specified in the Contract. In situations where full-width paving is not possible, paving in part widths may be permitted by the Engineer. Paving in part will be avoided, except in unavoidable circumstances. In case of part width paving, care shall be taken to ensure that while laying the next lane, bond between the remaining half length of tie bar or subsequently inserted tie bars and the newly laid concrete is adequately developed. Care shall be taken to avoid damage to the previous lane.

13.2.4.5.6 In case paving in separate lanes is allowed, work on the adjacent lane shall be permitted when the previously paved lane is cured for at least 14 days and is in a position to bear the weight of paving machine. When the wheels or crawler tracks are to ply on the already paved surface, necessary precautions shall be taken by placing protective pads of rubber or similar material so that texture is not damaged. The wheel or track shall be reasonably away from the edge to avoid damage to the previously laid slab.

13.2.4.5.7 Tube Floating

Upon the instructions of the Engineer, Contractor shall scrape the concrete surface when in plastic state with a 3 m long tube float fixed with a long and stable handle before texturing. Tube float shall be of an alloy steel tube of 50 to 60 mm diameter with a long and stable handle. The length of tube float shall preferably be longer than half the length of slab i.e., half the distance between two transverse contraction joints. This operation shall be done to minimize surface irregularity caused due to varied causes like frequent stoppages of work, surface deformation due to plastic flow etc. The tube float shall be placed at the centre of the slab parallel to longitudinal joint and pulled slowly and uniformly towards the edges. After the use of float tube, it shall be frequently cleaned before further use. The slurry removed shall be discarded. This activity shall be advanced laterally by providing an overlap of half the length of tube float. The removal of the cement slurry from the surface shall be sufficient enough such that the texture is formed on a firm surface and is more durable. This operation, however, shall be carried out after removing bleeding water.

13.2.4.6 Construction by Fixed Form Paver

13.2.4.6.1 The fixed form paving train shall consist of separate powered machines which spread, compact and finish the concrete in a continuous operation.

13.2.4.6.2 The concrete shall be discharged without segregation into a hopper spreader which is equipped with means for controlling its rate of deposition on to the sub-base. The spreader shall be operated to strike off concrete upto a level requiring a small amount of cutting down by the distributor of the spreader. The distributor of spreader shall strike off the concrete to the surcharge adequate to ensure that the vibratory compactor thoroughly compacts the layer. If necessary, poker vibrators shall be used adjacent to the side forms and edges of the previously constructed slab. The vibratory compactor shall be set to strike off the surface slightly high so that it is cut down to the required level by the oscillating beam. The machine shall be capable of being rapidly adjusted for changes in average and differential surcharge necessitated by changes in slab thickness or cross fall. The final finisher shall be able to finish the surface to the required level and smoothness as specified, care being taken to avoid bringing up of excessive mortar to the surface by over working.

13.2.4.7 Semi-mechanized Construction

Areas in which hand-guided methods of construction become indispensable shall be got approved by the Engineer in writing in advance. Such work may be permitted only in restricted rooster small lengths. Work shall be carried out by skilled personnel as per methods approved by the Engineer. The acceptance criteria regarding level, thickness, surface regularity, texture, finish, strength, of concrete and all other quality control measures shall be the same as in the case of machine laid work. Guidelines on the use of plants, equipment, tools, hauling of mix, compaction floating, straight edging, texturing, edging etc. shall be as per IRC:15.

13.2.4.8 Transition Slabs

At the interface of rigid and flexible pavement, at least 3 m long reinforced buried slab shall be provided to give a long lasting joint at the interface. The details shall be as given in IRC:15.

13.2.4.9 Anchor Beam and Terminal Slab Beam Adjoining Bridge Structures

RCC anchor beams shall be provided in the terminal slab adjoining bridge structures as per drawings and IRC:15.

13.2.4.10 The Treatment of Concrete Pavement on Culverts

The concrete pavement shall be taken over the culverts. At both ends of the culvert slab, a contraction joint shall be provided in the concrete pavement. Nominal reinforcement of 10mm dia bars at 150 mm spacing in both directions shall be provided at 50 mm below the top of the slab. The reinforcement shall be stopped 50 mm short of the contraction joint. Such reinforcement shall also be provided in the next slab panel on either side.

13.2.4.11 Surface Texture

13.2.4.11.1 Tining

After final floating and finishing of the slab and before application of the liquid curing membrane, the surface of concrete slabs shall be textured either in the transverse direction (i.e. at right angles to the longitudinal axis of the road) or in longitudinal direction (i.e., parallel to the centreline of the roadway). The texturing shall be done by tining the finished concrete surface by using rectangular steel tines. A beam or a bridge mounted with steel tines shall be equipped and operated with automatic sensing and control devices from main paver or auxiliary unit. The tining unit shall have facility for adjustment of the downward pressure on the tines as necessary to produce the desired finish. The tining rakes shall be cleaned often to remove spots of slurry. The tines shall be inspected daily and all the damaged and bent tines shall be replaced before commencing texturing. Tined grooves shall be 3 mm wide and 3 to 4 mm deep. Before commencing texturing, the bleeding water, if any, shall be removed and texturing shall be done on a firm surface. The measurement of texture depth shall be done as per Clause 602.12.

- (a) **Transverse tining :** When the texturing is specified in transverse direction, a beam of at least 3 m length mounted with tines shall be moved in transverse direction to produce the texture. The grooves produced shall be at random spacing of grooves but uniform in width and depth. The spacing shall conform to a pattern shown below:

Random spacing in mm

10	14	16	11	10	13	15	16	11	10	21	13	10
----	----	----	----	----	----	----	----	----	----	----	----	----

The above pattern shall be repeated. Texturing shall be done at the right time such that the grooves after forming shall not close and they shall not get roughened. Swerving of groove patterns will not be permitted. The completed textured surface shall be uniform in appearance.

- (b) **Longitudinal tining :** Longitudinal tining shall be done, if specified in the Contract. The texturing bridge shall be wide enough to cover the entire width of the carriageway but within 75 mm from the pavement edge. The centre to centre spacing between the tines shall be 18 to 21 mm. The width of tine texture shall be 3 mm and depth shall be 3 to 4 mm.

13.2.4.11.2 Brush Texturing

Alternatively on the instructions of the Engineer, the brush texturing shall be applied. The brushed surface texture shall be applied evenly across the slab in one direction by the use of a wire brush not less than 450 mm wide but wider brushes normally of 3 m length are preferred. The brush shall be made of 32 gauge tape wires grouped together in tufts placed at 10 mm centres. The tufts shall contain an average of 14 wires and initially be 100 mm long. The brush shall have two rows of tufts. The rows shall be 20 mm apart and the tufts in one row shall be opposite the centre of the gap between tufts in the other row. The brush shall be replaced when the shortest tuft wears down to 90 mm long.

The texture depth shall be determined by the Sand Patch Test as described in the Clause 602.12. This test shall be performed at least once for each day's paving and wherever the Engineer considers it necessary at times after construction as under:

Five individual measurements of the texture depth shall be taken at least 2 m apart anywhere along a diagonal line across a lane width between points 50 m apart along the pavement. No measurement shall be taken within 300 mm of the longitudinal edges of a concrete slab constructed in one pass.

Texture depths shall not be less than the minimum required depth when measurements are taken as given" in Table 600-5 nor greater than an average of 1.25 mm.

Table 600-5 : Texture Depth

Time of Test		Number of Measurements	Required Texture Depth (mm)	
			Specified Value	Tolerance
1)	Between 24 hours and 7 days after the construction of the slab or until the slab is first used by vehicles	An average of 5 measurements	1.00	:to.25
2)	Not later than 6 weeks before the road is opened to traffic	An average of 5 measurements	1.00	+0.25 -0.35

After the application of the brushed texture, the surface of the slab shall have a uniform appearance

Where the texture depth requirements are found to be deficient, the Contractor shall make good the texture across the full lane width over the length directed by the Engineer, by retexturing the hardened concrete surface in an approved manner.

13.2.4.12 Curing

13.2.4.12.1 Immediately after the surface texturing, the surface and sides of the slab shall be cured by the application of approved resin-based aluminized reflective curing compound which hardens into an impervious film or membrane with the help of mechanical sprayer.

13.2.4.12.2 The curing compound shall not react chemically with the concrete and the film or membrane shall not crack, peel or disintegrate within three weeks of application. Immediately prior to use, the curing compound shall be thoroughly agitated in its containers. The rate of spread shall be in accordance with the manufacturer’s instructions checked during the construction of the trial length and subsequently whenever required by the Engineer. The mechanical sprayer shall incorporate an efficient mechanical device for continuous agitation and mixing of the compound during spraying. The curing compound shall be sprayed in two applications to ensure uniform spread.

Curing compounds shall contain sufficient flake aluminum in finely divided dispersion to produce a complete coverage of the sprayed surface with a metallic finish. The compound shall become stable and impervious to evaporation of water from the surface of the concrete within 60 minutes of application and shall be of approved type. The curing compounds shall have a water retention efficiency index not less than 90 percent in accordance with BS Specification No. 7542 or as per ASTM C-309-81 Type 2.

13.2.9.12.4 In addition to spraying of curing compound, the fresh concrete surface shall be protected for at least 3 hours by covering the finished concrete pavement with tents mounted on mobile trusses as described in Clause 602.7.2, during adverse weather conditions as directed by the Engineer. After three hours, the pavement shall be covered by moist hessian laid in two layers and the same shall then be kept damp for a minimum period of 14 days after which time the hessian may be removed. The hessian shall be kept continuously moist. All damaged/torn hessian shall be removed and replaced by new hessian on a regular basis.

13.2.9.12.5 The Contractor shall be liable at his cost to replace any concrete damaged as a result of incomplete curing or cracked on a line other than that of a joint as per procedure in IRC:SP:83.

13.2.10 Preparation and Sealing of Joint Grooves

13.2.10.1 General

All joints shall be sealed using sealants described in Clause 602.2.10.

13.2.10.2 Preparation of Joint Grooves for Sealing

13.2.10.2.1 Grooves are saw cut in the first instance just to provide minimum width (3-5 mm) to facilitate development of crack at joint locations, as shown in the drawing.

Subsequently before sealing, grooves are widened by sawing as per the dimensions in the drawing. Dimension of the grooves shall be controlled by depth/width gauge.

13.2.10.2.2 If rough arises develop when grooves are made, they shall be ground to provide a chamfer approximately 5 mm wide. If the groove is at an angle upto 100 from the perpendicular to the surface, the overhanging edge of the groove shall be sawn or ground perpendicular. If spalling occurs or the angle of the former is greater than 10 degree, the joint sealing groove shall be sawn wider and perpendicular to the surface to encompass the defects upto a maximum width, including any chamfer, of 20 mm for transverse joints and 10 mm for longitudinal joints. If the spalling cannot be so eliminated then the arises shall be repaired by an approved thin bonded arises repair using cementitious/epoxy mortar materials.

13.2.10.2.3 All grooves shall be cleaned of any dirt or loose material by air blasting with filtered, oil-free compressed air. The Engineer shall instruct cleaning by pressurized water jets. Depending upon the requirement of the sealant manufacturer, the sides of the grooves shall be sand blasted to increase the bondage between sealant and concrete.

13.2.10.2.4 The groove shall be cleaned and dried at the time of priming and sealing. If sand blasting is recommended by the supplier, the same shall be carried out.

13.2.10.2.5 Before sealing the temporary seal provided for blocking the ingress of dirt, soil etc., shall be removed. A highly compressible heat resistant paper-backed demanding strip as per drawing shall be inserted in the groove to serve the purpose of breaking the bond between sealant and the bottom of the groove and to plug the joint groove so that the sealant may not leak through the cracks. The width of demanding strip shall be more than the joint groove Width so that it is held tightly in the groove. In the case of longitudinal joints, heat resistant tapes may be inserted to block the leakage through bottom of the joint where hot poured sealant is used. When cold poured sealant is used a demanding tape of 1.0-2.0 mm thickness and 6 to 8 mm width shall be inserted to plug the groove so that the sealant does -not enter in the initially cut groove.

13.2.10.3 Sealing with Sealants

13.2.10.3.1 When sealants are applied, an appropriate primer shall also be used if recommended by the manufacturer and it shall be applied in accordance with his instructions. The sealant shall be applied within the minimum and maximum drying times of the primer recommended by the manufacturer. Priming and sealing with applied sealants shall not be carried out when the naturally occurring temperature in the joint groove to be sealed, is below 7°C.

13.2.10.3.2 If hot applied sealant is used it shall be heated and applied from a thermostatically controlled, indirectly heated preferably with oil jacketed melter and pourer having recirculating pump and extruder. For large road projects, sealant shall be applied with extruder having flexible hose

and nozzle. The sealant shall not be heated to a temperature higher than the safe heating temperature and not for a period longer than the safe heating period, as specified by the manufacturer. The dispenser shall be cleaned out at the end of each day in accordance with the manufacturer's recommendations and reheated material shall not be used. The Movement Accommodation Factor of the sealant shall be more than 10 percent.

13.2.10.3.3 Cold applied sealants with chemical formulation like polysulphide / polyurethane/ silicone as per IRC:57 shall be used These shall be mixed and applied within the time limit specified by the manufacturer. If primers are recommended they shall be applied neat with an appropriate brush. The Movement Accommodation Factor shall be more than 25 percent.

13.2.10.3.4 The sealants applied at contraction phase of the slabs would result in bulging of sealant over and above the slab. Therefore, the Contractor in consultation with the Engineer, shall establish the right temperature and time for applying the sealant. Thermometer shall be hung on a pole at the site for facilitating control during the sealing operation.

13.2.10.3.5 Sealant shall be applied, slightly to a lower level than the slab with a tolerance of 3 ± 1 mm.

13.2.10.3.6 During sealing operation, it shall be seen that no air bubbles are introduced in the sealant either by vapours or by the sealing process. The sealant after pouring, shall be allowed to cure for 7 days or for a period as per instructions of manufacturers.

13.2.11 Trial Length

13.2.11.1 The trial shall be constructed at least one month in advance of the proposed start of concrete paving work. At least one month prior to the construction of the trial length, the Contractor shall submit for the Engineer's approval a detailed method statement giving description of the proposed materials, plant, equipment and construction methods. All the major equipments like paving train, batching plant, tipping trucks etc., proposed in the construction are to be approved by the Engineer before their procurement. No trials of new materials, plant, equipment or construction methods, nor any development of them shall be permitted either during the construction of trial length or in any subsequent paving work, unless they form part of further trials. The trial lengths shall be constructed away from the carriageway.

13.2.11.2 The Contractor shall demonstrate the materials, plant, equipment and methods of construction that are proposed for concrete paving, by first constructing a trial length of slab, at least 100 m long for mechanized construction and at least 50 m long for hand guided methods. The width of the trial section shall be the full carriageway width as shown in the drawings. If the first trial is unsatisfactory, the Contractor shall have to demonstrate his capability to satisfactorily construct the pavement in subsequent trials.

13.2.11.3 The trial length shall be constructed in two parts over a period comprising at least part of two separate working days, with a minimum of 50 m constructed each day for mechanized construction and a minimum of 25 m on each day for hand guided construction. The trial length shall be constructed at a paving rate which is proposed for the main work.

13.2.11.4 Transverse joints including expansion joint and longitudinal joint that are proposed in the main work shall be constructed and assessed in the trial length.

13.2.11.5 The trial length shall comply with the Specifications in all respects including the test requirement of Table 900-6 with the following additions

13.2.11.5.1 Surface Levels and Regularity

- (a) In checking for compliance with Clause 902.3 the levels shall be taken at intervals at the locations specified in this Clause along any line or lines parallel to the longitudinal centre line of the trial length.

- (b) The maximum number of permitted irregularities of pavement surface shall comply with the requirements of Clause 902.4. Shorter trial lengths shall be assessed pro-rata based on values for a 300 m length.

13.2.11.5.2 Joints

- (a) Alignment of dowel bars shall be inspected in any two consecutive transverse joints in a trial length construction by removing the fresh concrete in a width of 0.5 m on either side of the joint. The joint pit shall be refilled with freshly prepared concrete, after inspection. Alternatively, it can be tested by suitable device like MIT SCAN with the permission of the Engineer. If the position or alignment of the dowel bars at one of these joints does not comply with the requirements and if that joint remains the only one that does not comply after the next 3 consecutive joints of the same type have been inspected, then the method of placing dowels shall be deemed to be satisfactory. In order to check sufficient joints for dowel bar alignment without extending the trial length unduly, joints may be constructed at more frequent joint intervals than the normal spacing required in trial slabs.
- (b) If there are deficiencies in the first expansion joint that is constructed as a trial, the next expansion joint shall be a trial joint. Should this also be deficient, further trial of expansion joints shall be made as part of the trial length which shall not form part of the permanent works, unless agreed by the Engineer.

13.2.11.5.3 Density

In-situ density in trial length shall be assessed as described in Clause 903.5.2.2 from at least 3 cores drilled from each part of the trial length when the concrete is not less than 7 days old. Should any of the cores show honey-combing in the concrete, the trial length shall be rejected and the construction in the main carriageway shall not be permitted until further trials have shown that modification has been made which would result in adequate compaction.

13.2.11.5.4 Strength

Minimum of thirty (30) beams for flexural strength and thirty (30) cubes for compressive strength shall be prepared from the concrete delivered in front of the paving plant. Each pair of beams and cubes shall be from the same location/batch but different sets of beams and cubes shall be from different locations/batches. Compressive and flexural strength shall be tested after 28 days water curing in the laboratory. At the age of 28 days, thirty (30) cores with diameter 150 mm shall be cut from the pavement slab when the thickness of concrete pavement is more than 300 mm. In case the concrete pavement thickness is less than 300 mm, the diameter of core shall be 100 mm. The cores shall be suitably cut at both ends to provide a specimen of plain surface on both ends. The diameter to height ratio of core shall be 1 to 2. For cylindrical specimen of PQC of diameter 150 mm, the variation in diameter shall be ± 0.5 mm, a tolerance on height shall be ± 1 mm for a specimen of height 300 mm or more. For cylindrical specimen of diameter 100 mm, the variation in diameter shall be ± 0.3 mm, and a tolerance on height shall be ± 1 mm for a specimen height of 200 mm. The compressive strength test shall be conducted as per IS:516.

Concrete in the member represented by a core test shall be considered acceptable, if the average equivalent cube strength of the cores is equal to at least 85 percent of the cube strength (characteristic strength) of the grade of the concrete specified for the corresponding age of 28 days and no individual core has a strength less than 75 percent.

13.2.11.6 Approval and Acceptance

13.2.11.6.1 Approval of the materials, plant, equipment and construction methods shall be given when the trial length complies with the Specifications. The Contractor shall not proceed with normal

working until the trial length has been approved. If the Engineer does not notify the Contractor of any deficiencies in any trial length within 7 days after the completion of that trial length, the Contractor may assume that the trial length, and the materials, plant, equipment and construction methods adopted are acceptable, provided that the 28 days strength of cubes and cores extracted from trial length meet the requirement of the Specified strength.

13.2.11.6.2 When approval has been given, the materials, plant, equipment and construction methods shall not thereafter be changed, except for normal adjustments and maintenance of plant, without the approval of the Engineer. Any changes in materials, plant, equipment, and construction methods shall entitle the Engineer to require the Contractor to lay a further trial length as described in this Clause to demonstrate that the changes will not adversely affect the permanent works.

13.2.11.6.3 Trial lengths which do not comply with the Specifications, with the exception of areas which are deficient only in surface texture and which can be remedied in accordance with Clause 602.9.11.6 shall be removed immediately upon notification of deficiencies by the Engineer and the Contractor shall construct a further trial length.

13.2.11.7 Inspection of Dowel Bars

13.2.11.7.1 Compliance with Clause 602.6.5. for the position and alignment of dowel bars at contraction and expansion joints shall be checked by measurements relative to the side forms or guide wires.

13.2.11.7.2 When the slab has been constructed, the position and alignment of dowel bars and any filler board shall be measured after carefully exposing them in the plastic concrete across the whole width of the slab. When the joint is an expansion joint, the top of the filler board shall be exposed sufficiently in the plastic concrete to permit measurement of any lateral or vertical displacement of the board. During the course of normal working, these measurements shall be carried out in the pavement section at the end of days-work by extending slab length by 2 m. After sawing the transverse joint groove, the extended 2 m slab shall be removed carefully soon after concrete has set to expose dowels over half the length. These dowels can be tested for tolerances. This joint shall be treated as construction joint. The position of dowel bars in any type of transverse joint is, contraction, construction or expansion can alternatively be tested by suitable device like MIT SCAN with the permission of the Engineer.

13.2.11.7.3 If the position and alignment of the bars in a single joint in the slab is unsatisfactory then the next two joints shall be inspected. If only one joint of the three is defective, the rate of checking shall be increased to one joint per day until the Engineer is satisfied that compliance is being achieved.

13.2.11.7.4 After the dowel bars have been examined, the remainder of the concrete shall be removed over a width of 500 mm on each side of the line of the joint and reinstated to the satisfaction of the Engineer. The dowels shall be inserted on both sides of the 1 m wide slab by drilling holes and grouting with epoxy mortar. Plastic sheath as per Clause 602.6.5.5 shall be provided on dowels on one of the joints. The joint groove shall be widened and sealed as per Clause 602.10.

13.2.11.8 Inspection of Tie Bars

To check the position of the tie bars, one metro length 0.5 m on either side of the longitudinal joint shall be opened when the concrete is green (within 20 to 30 minutes of its laying). The pit shall be ravelled with the fresh concrete of same mix after checking.

13.2.12 Measurement of Texture Depth - Sand Patch Method

13.2.12.1 The following Apparatus shall be used:

- (i) A cylindrical container of 25 ml internal capacity;
- (ii) A flat wooden disc 64 mm diameter with a hard rubber disc, 1.5 mm thick, next to one face, the reverse face being provided with a handle;
- (iii) Dry natural sand with a rounded particle shape passing a 300 micron IS sieve and retained on a 150 micron is sieve.

13.2.12.2 Method

The surface to be measured shall be dried, any extraneous mortar and loose material removed and the surface swept clean using a wire brush both at right angles and parallel to the carriageway. The cylindrical container shall be filled with the sand, tapping the base 3 times on the surface to ensure compaction, and striking off the sand level with the top of the cylinder. The sand shall be poured into a heap on the surface to be treated. The sand shall be spread over the surface, working the disc with its face kept flat in a circular motion so that the sand is spread into a circular patch with the surface depressions filled with sand to the level of peaks.

13.2.12.3 The diameter of the patch shall be measured to the nearest 5 mm. The texture depth of concrete surface shall be calculated from $31000/(D \times D)$ mm where D is the diameter of the patch in mm.

13.2.12.4 Measurement of Texture Depth - Tining

13.2.12.4.1 The following apparatus shall be used :

- (i) Tire Tread Depth Gauge

A stainless steel tire tread depth gauge with graduations with least count of 1.0 mm. The gauge end may be modified to measure depth of tine texture.

- (ii) A stainless steel caliper to measure spacing of tines. If necessary the caliper may be modified to measure the spacing and width of tine texture. The gauge shall be used after making necessary calibration.

- (iii) Wire brush

- (iv) Corborundum stone

- (v) Steel straight edge to remove snots etc. sticking to the surface. The straight edge may be of 6 x 25 x 300 mm size.

13.2.12.4.2 Test Section

A unit of testing shall be 75 m per lane. If the length of construction is less than 75 m it shall be taken as one unit.

13.2.12.4.3 Test Procedure

In each 75 m section, along the diagonal line, 10 points shall be selected for making checks of depth, width and spacing of tine grooves. The surface where tests are to be conducted shall be cleared carefully with a wire brush or a steel straight edge or using a carborundum plate to remove any upward projection of concrete. When the base plate of the gauge is in contact with the concrete surface the gauge shall be pressed to the bottom of groove and the depth shall be measured and recorded at this location. At the same location, the spacing of tines shall be measured to verify whether the pattern recommended in Clause 602.9.11.1 is complied or not.

The average of depth and width at 10 locations shall be calculated and recorded to the nearest 1 mm. The spacing of spectrum measured at 10 locations shall be recorded separately.

13.2.12.5 The average depth shall be 3 to 4 mm. When the depth is less than 2.5 mm and in excess of 4.5 mm, the Contractor shall stop concreting till he corrects his trowel brush or replaces it. The sensors associated with work shall be again calibrated to achieve, the required texture. The textured groove less than 2.5 mm shall be re-grooved using, concrete saw at the cost of Contractor. Variation in texture width in the range of 3+1 mm and " 3 - 0.5 mm will be acceptable. If the variation of width is in excess of this range, the Contractor shall stop work and correct the brush and technique. When the spacing of spectrum is not satisfactory, the Contractor shall replace the entire brush.

13.2.13 Opening to Traffic

No vehicular traffic shall be allowed to ply on the finished surface of a concrete pavement within a period of 28 days of its construction and until the joints are permanently sealed and cured. The road may be opened to regular traffic after completion of the curing period of 28 days and after sealing of joints is completed including the construction of shoulder, with the written permission of the Engineer.

13.2.14 Acceptance Criteria in Quality and Distress

- (i) **Tolerances for Surface Regularity, Level, Thickness and Strength:** The tolerances for surface regularity, level, thickness and strength shall conform to the requirements given in Clause 903.5. Control of quality of materials and works shall be exercised by the Engineer in accordance with Section 900.
- (ii) **Tolerances in Distress :** The acceptance criteria with regard to the types of distresses in rigid pavement shall be as per IRC:SP-83. Guidelines for Maintenance, Repair and Rehabilitation of Cement Concrete Pavements". The cracks (of severity rating not more than 2) which may appear during construction or before completion of Defect Liability Period shall be acceptable with suggested treatments as given in IRC:SP-83.

Cement Concrete Pavement slabs having cracks of severity rating more than 2 i.e. cracks of width more than 0.5 mm for single discrete cracks, multiple and transverse cracks and cracks of width more than 3 mm in case of longitudinal cracks and of depth more than half of the concrete pavement slabs, shall be removed and replaced as per IRC:SP-83.

13.2.15 Measurements for Payment

13.2.15.1 Cement Concrete pavement shall be measured as a finished work in cubic metres of concrete placed based on the net plan area and thickness as measured in accordance with Clause 602.15.2.

13.2.15.2 The finished thickness of concrete for payment on volume basis shall be computed in the manner described in Clause 113.3 with the following modifications:

- (i) The levels shall be taken before and after construction at grid points 5 m centre to centre longitudinally in straight as well as at curves.
- (ii) A day's work is considered as a 'lot' for calculating the average thickness of the slab. In calculating the average thickness, individual measurements which are in excess of the specified thickness by more than 10 mm shall be considered as the specified thickness plus 10 mm.

13.2.15.3 Individual areas deficient by more than 10 mm shall be verified by the Engineer by ordering core cutting and if in his opinion the deficient areas warrant removal, they shall be removed and replaced with concrete of the thickness shown on the plans.

13.2.16 Rate

13.2.16.1 The Contract unit rate for the construction of the cement concrete pavement shall have payment in full for carrying out the operations required for the different items of the work as per these Specifications including full compensation for all labour, tools, plant, equipment, providing all

materials i.e. aggregates, dowel bars, tie bars, PVC membrane, cement, stabilizers (lime, cements or any other stabilizers approved by the Engineer), storing, mixing, transportation, placing, compacting, finishing, curing, testing, all royalties, fees, rents where necessary, all leads and lifts and incidentals to complete the work as per Specifications.

The unit rate shall include the full costs of construction, expansion, contraction and longitudinal joints including joint filler, sealant, primer, expansion strip and all other operations for completing the work. The construction and testing of trial length shall be included in the contract unit rate for the pavement and shall not be paid separately.

13.2.16.2 Where the average thickness for the lot is deficient by the extent shown in Table 600-6, payment for cement concrete pavement shall be made at a price determined by adjusting the contract unit price as per Table 600-6.

Table 600-6 : Payment Adjustment for Deficiency in Thickness

Deficiency in the Average Thickness of Day's Work	Percent of Contract Unit Price Payable
Up to 5 mm	100
mm	87

13.2.16.3 No additional payment shall be made for the extra thickness of the slab than shown on the drawings.

14.1. TRAFFIC SIGNS AND ROAD MARKING (Morth 5th Revision Section-800)

14.2. Scope: The work shall consist of the fabrication, supply and installation of ground mounted traffic signs on roads. The details of the signs shall be as shown in the drawings and in conformity with the Code of Practice for Road Signs, IRC: 67-2012.

14.3. Materials: The various materials and fabrication of the traffic signs shall conform to the following requirements:

14.3.1. Concrete: Concrete for foundation shall be of M 15 Grade as per Section 1700 or the grade shown on the drawings or otherwise as directed by the Engineer.

14.3.2. Reinforcing Steel: Reinforcing steel shall conform to the requirement of IS: 1786 unless otherwise shown on the drawing.

14.3.3. Bolts, Nuts, Washers: High strength bolts shall conform to IS: 1367 whereas precision bolts, nuts, etc., shall conform to IS: 1364.

14.3.4. Plates and Supports:-Plates and support sections for the sign posts shall conform to IS:226 and IS: 2062 or any other relevant IS Specifications.

14.3.5. Substrate:-Sign panels shall be fabricated on aluminium sheet, aluminium composite panel, fiber glass sheeting, or sheet moulding compound. Aluminium sheets used for sign boards shall be of smooth, hard and corrosion resistant aluminium alloy conforming to IS: 736-Material Designation 24345 or 1900. Aluminium Composite Material (ACM) sheets shall be sandwiched construction with a thermoplastic core of Low Density Polyethylene (LOPE) between two thick skins/sheets of aluminium with overall thickness and 3 mm or 4 mm (as specified in the Contract), and aluminium skin of thickness 0.5 mm and 0.3 mm respectively on both sides. The mechanical proportion of ACM and that of aluminium skin shall conform to the requirements given in Table 800-1(Morth 5th), when tested in accordance with the test methods mentioned against each of them.

14.3.6. Plate Thickness:-Shoulder mounted ground signs with a maximum side dimension not exceeding 600 mm shall not be less than 1.5 mm thick with Aluminium and 3 mm thick with Aluminium Composite Material. All other signs be at least 2 mm thick with Aluminium and 4mm thick with Aluminium Composite Material. The thickness of the sheet shall be related to the size of the sign and its support and shall be such that it does not bend or deform under prevailing wind and other loads.

14.3.7. In respect of sign sizes not covered by IRC: 67, the structural details (thickness, etc.) shall be as per the approved drawings or as directed by the Engineer.

14.4. Traffic Signs having Retro-Reflective Sheeting

14.4.1. General Requirements:-The retro-reflective sheeting used on the sign shall consist of the white or colored sheeting having a smooth outer surface which has the property of retro-reflection over its entire surface it shall be weather-resistant and show color fastness. It shall be new and unused and shall show no evidence of cracking, scaling, and pitting, blistering, edge lifting or curling and shall have negligible shrinkage or expansion. A certificate of having tested the sheeting for co-efficient of retro-reflection, day/night time color luminous, shrinkage, flexibility, linear removal, adhesion, impact resistance, specular gloss and fungus resistance and its having- passed these tests shall be obtained from a Government Laboratory/institute, by the manufacturer of the sheeting. The retro-reflective sheeting shall be either of Engineering Grade material with enclosed lens, High Intensity Grade with

encapsulated lens or Micro-prismatic Grade retro-reflective element material as given in Clauses 801.3.2 to 801.3.7. Guidance on the recommended application of each class of sheeting may be taken from IRC: 67.

14.4.2. Sign panels shall be fabricated on aluminium sheet, aluminium composite panel, fibre glass sheeting, or sheet moulding compound. Aluminium sheets used for sign boards shall be of smooth, hard and corrosion resistant aluminium alloy conforming to 13:736-Material designation 24345 or 1900. Aluminium Composite Material (ACM) sheets shall be sandwiched construction with a thermoplastic core of Low Density Polyethylene (LDPE) between two thick skins/sheets of aluminium with overall thickness and 3 mm or 4 mm (as specified in the Contract), and aluminium skin of thickness 0.5 mm and 0.3 mm respectively on both sides.

The mechanical proportion of ACM and that of aluminium skin shall conform to the requirement given in Table 800-1, when tested in accordance with the test methods mentioned against each of them.

Table 800-1of MoRTH: Specifications for Aluminium Composite Material (ACM)

S. No.	Description	Specification	
		Standard Test	Acceptable Value
A	Mechanical Properties of ACM		
1)	Peel off strength with retro reflective sheeting (Drum Peel Test)	ASTM D903	Min. 4 Nimm
2)	Tensile strength	ASTM E8	Min. 40 Nimm
3)	0.2% Proof Strees	ASTM E8	Min. 34 Nimm
4)	Elongation	ASTM E8	Min. 6%
5)	Flexural strength	ASTM 393	Min. 130 Nimm ²
6)	Flexural modulus	ASTM 393	Min. 44.00 N/mm ²
7)	Shear strength with Punch shear test	ASTM 732	Min. 30 Nimm ²
B	Properties of Aluminium Skin		
1)	Tensile strength (Rm)	ASTM E8	Min. 65 Nimm ²
2)	Modulus of elasticity	ASTM E8	Min. 70,000 N/mm ²
3)	Elongation,	ASTM E8	A50 Min. 2%
4)	0.2% Proof Stress	ASTM E8	Min. 10N/mm ²

14.4.3. Messages/Borders

The messages (legends, letters, numerals etc.) and borders shall either be screen-printed or of cut out from durable transparent overlay or cut out from the same type of reflective sheeting for the cautionary/mandatory sign boards. Screen printing shall be processed and finished with materials and in a manner specified by the sheeting manufacturer. For the informatory and other sign boards, the messages (legends, letters, numerals etc.) and borders shall be cut out from durable transparent overlay film or cut-out from the same reflective sheeting only. Cut-outs shall be from durable transparent overlay materials as specified by the sheeting manufacturer and shall be bonded with the sheeting in the manner specified by the manufacturer. For screen-printed transparent colored areas on white sheeting, the coefficient of retro-reflection shall not be less than 50 percent of the values of corresponding color in Tables 800-2 to 800-8 as applicable. Cut-out messages and borders, wherever used, shall be either made out of retro-reflective

sheeting or made out of durable transparent overlay except those in black which shall be of non-reflective sheeting or opaque in case of durable transparent overlay.

14.4.4. Color for Signs

- 14.4.4.1. Signs shall be provided with retro-reflective sheeting and/or overlay film/screening ink.
- 14.4.4.2. The reverse side of all signs shall be painted grey.
- 14.4.4.3. Except in the case of railway level crossing signs the sign posts shall be painted in 250mm side bands, alternately black and white. The lowest band next to be ground shall be in black.
- 14.4.4.4. The color of the material shall be located within the area defined by the chromaticity coordinates in Table 800-7 and comply with the luminance factor when measured as per ASTM 0-4956(Morth 5th). The colors shall be durable and uniform in acceptable hue when viewed in day light or under normal headlights at night.
- 14.4.4.5. The Regulatory/Prohibitory and warning signs shall be provided with white background and red border. The legend/ symbol for these signs shall be in black color. The Mandatory sign shall be provided with Blue background and white Symbol/letter.
- 14.4.4.6. The colors chosen for informatory or guide signs shall be distinct for different classes of roads. For National Highways and State Highways, these signs shall be of green background and for Expressways these signs shall be of blue background with white border, legends and word messages.

14.4.5. Sizes of Letters

- 14.4.5.1. Letter size should be chosen with due regard to the speed, classification and location of the road, so that the sign is of adequate size for legibility but without being too large or obtrusive. The size of the letter, in terms of x-height, to be chosen as per the design speed is given in Table 800-8(Morth 5th).
- 14.4.5.2. The thickness of the letters and their relation to the x-height, the width, and the heights are indicated in Table IV (a) of the Annexure-4 of IRC: 67 to facilitate the design of the informatory signs and definition plates.
- 14.4.5.3. For advance direction signs on non-urban roads, the letter size ('x' height) should be minimum of 150 mm for Expressway, National and State Highways and 100 mm for other roads. In case of overhead signs, the size ('X' height) of letters may be minimum 300 mm. Thickness of the letter could be varied from 1/6 to 1/5 of the letter 'x' size. The size of the initial uppercase letter shall be 1-1/3 times x-height. In urban areas, letter size shall be 100 mm on all directional signs. For easy and better comprehension, the word messages shall be written in upper case letters only.
- 14.4.5.4. Letter size on definition plates attached with normal sized signs should be 100 mm or 150 mm. In the case of small signs, it should be 100 mm. Where the message is long, as for instance in "NO PARKING" and "NO STOPPING" signs, the message may be broken into two lines and size of letters may be varied in the lines so that the definition plate is not too large. The lettering on definition plates will be all in upper case letters.

14.4.6. Warranty and Durability:-The Contractor shall obtain from the manufacturer a ten year warranty for satisfactory field performance including stipulated retro-reflectance of the retro-reflective sheeting of micro-prismatic sheeting and a seven-year warranty for high intensity grade and submit the same to the Engineer. The warranty shall be inclusive of the screen

printed or cut out letters/legends and their bonding to the retro-reflective sheeting. The Contractor supplier shall also furnish the LOT numbers and certification that the signs and materials supplied against the assigned work meets all the stipulated requirements and carry the stipulated warranty and that the Contractor supplier is the authorized converter of the particular sheeting.

All signs shall be dated during fabrication with indelible markings to indicate the start of warranty. The warranty shall also cover the replacement obligation by the sheeting manufacturer as well as contractor for replacement repair/restoration of the retro-reflective efficiency. A certificate in original shall be given by the sheeting manufacturer that its offered retroreflective sheeting has been tested for various parameters such as co-efficient of retro reflection, day/nighttime color and luminance, shrinkage, flexibility, linear removal, adhesion, impact resistance, specular gloss and fungus resistance; the tests shall be carried out by a Government Laboratory in accordance with various ASTM procedures and the results must show that the sheeting has passed the requirements for all the above mentioned parameters. A copy of the test reports shall be attached with the certificate.

14.5. Installation

14.5.1. The traffic signs shall be mounted on support posts, which may be of GI pipes conforming to IS:1239, Rectangular Hollow Section conforming to IS:4923 or Square Hollow Section conforming to IS:3589. Sign posts, their foundations and sign mountings shall be so constructed as to hold these in a proper and permanent position against the normal storm wind loads or displacement by vandalism. Normally, signs with an area up to 0.9 sq.m shall be mounted on a single post, and for greater area, two or more supports shall be provided. Post-end(s) shall be firmly fixed to the ground by means of properly designed foundation. The work of foundation shall conform to relevant Specifications as specified.

14.5.2. All components of signs (including its back side) and supports, other than the reflective portion and G.I. posts shall be thoroughly de-scaled, cleaned, primed and painted with two coats of epoxy / fiber glass powder coated paint. Any part of support post below ground shall be painted with protective paint.

14.5.3. The signs shall be fixed to the posts by welding in the case of steel posts and by bolts and washers of suitable size. After the nuts have been tightened, the tails of the bolts shall be furred over with a hammer to prevent removal.

14.6. Measurement for Payment:-The measurement of standard cautionary, mandatory and information signs shall be in numbers of different types of signs supplied and fixed, while for direction and place identification signs, these shall be measured by area in square meters.

<p>Standard colours</p> <p>Oxide red(+RAL3011)</p> <p>Signal red (+RAL3001)</p> <p>Traffic green (+RAL6024)</p> <p>Type</p> <p>2 pack coldcuring solvent free compound based on acrylic resins for hand application</p> <p>Features</p> <p>Easy to apply with texture roller. High durability . Very good adhesion on the road surface , also on concrete. Especially designed to accentuate bicycle-tracks and footpath's etc.</p> <p>Technical Characteristics :</p> <p>Viscosity : thick fluid compound density : Approx 1.8 Gram/cm3.</p> <p>Skid resistance : >45 S.R.T</p> <p>Hardening time : Approx 20 minutes Approx 30 minutes by 20 deg C Approx 40 minutes by . 10 deg C</p> <p>Flashpoint : approx. 10 deg C</p> <p>Storage stability : At least 6 months if stored in a cool place</p>	<p>Mixing ratio: 1 sachets of hardener to 10 kg Mlastitrak Roll on base</p> <p>Potlife (mixed): 10 minutes by 20 deg C</p> <p>Application</p> <p>Method: Mark out the surface, which has to be done with self-adhesive tape. Mix the plastitrak relocating with hardener and divide the material equally over the whole area. Immediately after application, the tape can be removed.</p> <p>Spreading rate : Approx 1.5 -2.0 kg/m3 at .8-1.2 mm thickness .</p> <p>Temperature : minimum application temperature is 10 deg C</p> <p>Primer : on dusty and sucking surfaces or fresh bituminous surfaces we advise to apply EP PRIMER first</p> <p>Weather conditions :Minimum application temperature is 10 deg C</p> <p>Cleaning : with thinner recommended by kataline.</p> <p>Handling: see material safety data sheet</p> <p>Packing :</p> <p>10 kg cans of plastitrak roll on base hardener in plastic sachets</p> <p>Remark :</p> <p>Other colours are available on request.</p>
---	---

14.7. Rate:-The Contract unit rate shall be payment in full for the cost of making the road sign, including all materials, installing it at the site furnishing of necessary test certificates, warranty and incidentals to complete the work in accordance with these Specifications.

14.8. ROAD MARKINGS

14.8.1. COLD APPLIED THERMOPLASTIC PAINT - High build Roll-On Road Surfacing Material

14.8.1.1. Scope:-The work shall consist of providing road markings of specified width, layout and design using paint of the required specifications as given in the Contract and as per guidelines contained in from IRC:35-1997.

14.8.1.2. Materials:-Road markings shall be of ordinary road marking paint hot applied thermoplastic compound, reflectorized paint or cold applied reflective paint as specified in the item and the material shall meet the requirements as specified in these Specifications.

14.8.2. Hot Applied Thermoplastic Road Marking

14.8.2.1. Thermoplastic Material

14.8.2.1.1. General:-The thermoplastic material shall be homogeneously composed of aggregate, pigment, resins and glass reflectorizing beads. The color of the compound shall be white or yellow (IS color No. 356) as specified in the drawings or as directed by the Engineer.

14.8.2.1.2. Requirements:

- (i) Composition: The pigment, beads, and aggregate shall be uniformly dispersed in the resin. The material shall be free from all skins, dirt and foreign objects and shall comply with requirements indicated in Table 800-9 (Morth 5th revision).
- (ii) Properties: The properties of thermoplastic material, when tested in accordance with ASTM D36/BS-3262-(Part I), shall be as below:
 - (a) Luminance: White: Daylight luminance at 45°-65 percent min. as per AASHTO M 249
Yellow: Daylight luminance at 45°-45 percent min. as per AASHTO M249
 - (b) Drying time: When applied at a temperature specified by the manufacturer and to the required thickness, the material shall set to bear traffic in not more than 15 minutes.
 - (c) Skid resistance: not less than 45 as per BS: 6044.
 - (d) Cracking resistance at low temperature: The material shall show no cracks on Application to concrete blocks.
 - (e) Softening point: $102.5^{\circ}\text{C} \pm 9.5^{\circ}\text{C}$ as per ASTM D 36.
 - (f) Yellowness index (for white thermoplastic paint): not more than 0.12 as per AASHTO M 249
- (iii) Storage life: The material shall meet the requirements of these Specifications for a period of one year. The thermoplastic material must also melt uniformly with no evidence of skins or un-melted particles for the one year storage period. Any material not meeting the above requirements shall be replaced by the manufacturer/supplier/ Contractor.
- (iv) Reflectorisation: Shall be achieved by incorporation of beads, the grading and other properties of the beads shall be as specified in Clause 803.4.2.
- (v) Marking: Each container of the thermoplastic material shall be clearly ~ and indelibly marked with the following information:
 - The name, trademark or other means of identification of manufacturer
 - Batch number
 - Date of manufacture
 - Color (white or yellow)
 - Maximum application temperature and maximum safe heating temperature.
- (vi) Sampling and Testing: The thermoplastic material shall be sampled and tested in accordance with the appropriate ASTM/BS method. The Contractor shall furnish to the Engineer a copy of certified test reports from the manufacturers of the thermoplastic material showing results of all tests specified herein and shall certify that the material meets all requirements of this Specification.

14.9. Reflective pavement markers (road studs) and solar powered road markers (solar studs)

14.9.1. Scope:-The work shall cover the providing and fixing of reflective pavement marker (RPM) or road stud, a device which is bonded to or anchored within the road surface, for lane marking and delineation for night-time visibility, as specified in the Contract.

14.9.2. Material

14.9.2.1. Plastic body of RPM/road stud shall be molded from ASA (Acrylic Styrene Acrylonitrile) or HIPS (Hi-impact Polystyrene) or Acrylonitrile Butadiene Styrene (ABS) or any other suitable material approved by the Engineer. The markers shall support a load of 13,635 kg tested in accordance with ASTM D 4280.6.9.2.2 Reflective panels shall consist of number of lenses containing single or dual prismatic cubes capable of providing total internal reflection of the light entering the lens face. Lenses shall be moulded of methyl methacrylate conforming to ASTM D 788 or equivalent.

14.10. Design:-The slope or retro-reflecting surface shall preferably be 35 ± 50 to base and the area of each retro-reflecting surface shall not be less than 13.0 sq.cm.

14.11. Optical Performance

14.11.1. Unidirectional and Bi-directional Studs:-Each reflector or combination of reflectors on each face of the stud shall have a Coefficient of Luminous Intensity (C.I.L) not less than that given in Tables 800-13 or 800-14 as appropriate.

14.11.2. Omni-directional Studs:-Each Omni-directional stud shall have a C.I.L. of not less than 2 mcd/lx.

14.12. Tests

14.12.1. Co-efficient of luminance intensity can be measured by procedure described in ASTM E

14.12.2. "Practice for Measuring Photometric Characteristics" or as recommended in BS: 873-Part 4: 1973.

14.12.3. Under test conditions, a stud shall not be considered to fail the photometric requirements if the measured C.I.L. at anyone position of measurement is less than the values specified in Tables 800-13 or 800-14 provided that

- (i) The value is not less than 80 percent of the specified minimum, and
- (ii) The average of the left and right measurements for the specific angle is greater than the specified minimum.

14.13. Fixing of Reflective Markers

14.13.1. Requirements: - The enveloping profile of the head of the stud shall be smooth and the studs shall not present any sharp edges to traffic. The reflecting portions of the studs shall be free from crevices or ledges where dirt might accumulate. Marker height shall not be less than 10 mm and shall not exceed 20 mm. and its width shall not exceed 130 mm. The base of the marker shall be flat within 1.3 mm. If the bottom of the marker is configured, the outermost faces of the configurations shall not deviate more than 1.3 mm from a flat surface. All road studs shall be legibly marked with the name, trade mark or other means of identification of the manufacturer.

14.13.2. Placement:-The reflective marker shall be fixed to the road surface using the adhesives and the procedure recommended by the manufacturer. No nails shall be used to affix the marker so that they do not pose safety hazard on the roads. Regardless of the type of adhesive used, the markers shall not be fixed if the pavement is not surface dry and on new asphalt concrete surfacing until the surfacing has been opened to traffic for a period of not less than 14 hours. The portions of the highway surface, to which the marker is to be bonded by the adhesive, shall be free of dirt, curing compound, grease, oil, moisture, loose or unsound layers, paint and any other material which would adversely affect the bond of the adhesive. The adhesive shall be placed uniformly on the cleaned pavement surface or on the bottom of the of the marker in a quantity sufficient to result in complete coverage of the area of contract of the marker with no voids present and with a slight excess after the marker has been lightly pressed in place. For epoxy installations, excess adhesive around the edge of the marker, excess adhesive on the pavement and adhesive on the exposed surfaces of the markers shall be immediately removed.

14.13.3. Warranty and Durability:-The contractor shall submit a two year warranty for satisfactory field performance including stipulated retro-reflectance of the reflecting panel, to the Engineer. In addition, a two year warranty for satisfactory infield performance of the finished road marker shall also be given by the contractor who carries out the work of fixing of reflective road markers. In case the markers are displaced, damaged, get worn out or lose their reflectivity compared to stipulated standards, the contractor would be required to replace all such markers within 15 days of the intimation from the Engineer, at his own cost.

14.13.4. Measurement for Payment:-The measurement of reflective road markers/solar powered road studs shall be in numbers of different types of markers supplied and fixed.

14.13.5. Rate:-The contract unit rate for reflective road markers/solar powered road studs shall be payment in full compensation for furnishing all labour, material, tools, equipment including incidental costs necessary for carrying out the work at site conforming to the specification complete as per approved drawings or as directed by the Engineer.

14.13.6. Road delineators

14.13.6.1. Scope:-The work shall cover supplying and fixing roadway indicators, hazard markers and object markers. Roadway indicators shall be properly installed to indicate the horizontal alignment and vertical profile of the roadway so as to outline the vehicle path for safe driving. Hazard markers shall be installed immediately ahead of obstruction of vehicular path such as just before a narrow bridge. Object markers shall be erected where obstruction within the roadway starts such as Channelizing Island in approaches to intersections.

14.13.6.2. The design, materials to be used and the location of the road delineators (roadway indicators, hazard markers and object markers) shall conform to Recommended Practice for Road Delineators, IRC:79, and to relevant drawings or as otherwise directed by the Engineer. The steel drums such as empty bitumen drums shall not be used as they could pose safety hazards, The delineators shall be retro-reflectORIZED as shown on the drawings or as directed by the Engineer. The reflectors on the delineators shall be of retroreflective sheeting with encapsulated lens and with the visibility of 300 m under clear weather conditions, when illuminated by the upper beam of the car headlights.

14.13.6.3. Installation:-The delineators shall be so installed that their posts do not change their orientation and the reflectORIZED faces are always perpendicular to the direction of travel.

14.13.6.4. Measurement for Payments:-the measurement shall be made in number of delineators supplied and fixed at site.

14.13.6.5. Rates:-The Contract unit rates of delineators shall be payment in full compensation for furnishing all labour, materials, tools, equipment including incidental costs necessary to complete the work to these Specifications.

14.14. Road traffic signals

14.14.1.Scope:-The work shall cover supply and installation of Road Traffic Signals. The traffic signal, its configuration, size and location shall be in accordance with IRC:93 and IS:7537 and as shown in the drawings or as directed by the Engineer. Prior to installation of signals, the Contractor shall submit to the Engineer, for approval, detailed proposals showing the signal type, sizes, paint and structural details of the signal posts including control system.

14.14.2.The traffic signals shall have a complete electronic mechanism for controlling the operation of traffic with an auxiliary manual controller. The time plan of signals shall be as per drawing and shall be modified as directed by the Engineer.

14.14.3.Materials:-The various materials and fabrication thereof shall conform to the following:

14.14.3.1. Signal Foundation:-The signal foundation shall be constructed as per Specifications given in Clause 13 of IRC: 93 or as shown in the drawings.

14.14.3.2. Construction Requirements:-The construction requirements for post, signal head assembly, signal head, optical system, lamp and holder, visor, post, supports for overhead mounted signals, equipment housing, locks, inter-connecting cables, earthing, mains termination, controller electrical components, etc. shall conform to IS:7537 unless otherwise stated in IRC:93. The post shall be painted and protected as per Clause 3.7 of IS: 7537.

14.14.3.3. Optical Requirements the shape of all signal lenses shall be circular and shall be of specified color and size and as shown in the drawing. Quality of lenses, arrangements of lenses, illuminations, visibility and shielding of signals shall be as per relevant Clauses of IRC:93 and IS:7537.

14.14.4.Tests shall be carried out on all components of traffic signals including tests on complete system for its performance as per relevant Clauses of IRC:93 and IS:7537.

14.14.5.Maintenance of Traffic Signals:-It shall be the responsibility of the Contractor to provide for maintenance of the signal section system throughout the warranty period for at least five (5) years after installation and as per Clause 18 of IRC: 93.

14.14.6.Measurement for Payment:-The measurement for traffic signalization system shall be by unit for complete work as specified and as per drawing for complete road junction.

14.14.7.Rate:-The Contract unit rate for the traffic signalization system as a whole shall be payment in full compensation for furnishing all labour, materials, tools, equipment for preparing, supplying, fixing at site, testing and maintenance throughout warranty period and all other incidental costs necessary to complete and maintain the work to these Specifications.

14.15. Traffic control and safety devices in construction zone

14.15.1.Scope:-The work shall cover supply and installation at site. Traffic Control Devices in the construction zone comprising of signs delineators, traffic cones, drums, barricades, longitudinal barriers, warning tapes, flagmen, reflective jackets, headgears.

14.15.2.Signs:-Traffic signs shall be in accordance with IRC: 67 and in accordance with IRC: SP:

14.15.3.Its material and other requirements shall be in accordance with Clause 801 of these Specifications.

14.15.4.Delineators:-Delineators in constructions zone are in form of vertical posts, cones, traffic cylinders, tapes, drums etc. Vertical posts shall be in accordance with the provisions contained in IRC: 79.

14.15.5.Traffic Cones

14.15.5.1. Traffic cones may be of height 500 mm, 750 mm and 1000 mm, and 300 to 500 mm in diameter or in a square shape. They shall be of brilliant red/orange/yellow, ultraviolet stabilized color for maximum visibility and fade resistance under all weather conditions and ambient working temperature of -30°C to +140°C. The material shall be Linear Low Density Polyethylene (LLDP), plastic or rubber so that there is no damage to the vehicle when they are stuck. Cone and base are to be of one continuous layer to prevent tearing and base separation they should be non-crushable flexible/tear resistant and UV stabilized and made from non-fading colors. They should return to their original shape in just 20 seconds after being crushed. The bases of cones shall be loaded with ballast (but they should not present a hazard if the cones are inadvertently struck) or anchored to check their being blown away. Their base should be designed for easy stacking without sticking. They may have retro-reflective white band and mounted flashing warning light for enhanced night visibility. All traffic cones shall conform to BS: 873 (part 8) Catalogue A and the provisional European Standard EN 13422.

14.15.5.2. The measurement shall be for each piece and payment for each piece.

14.15.6.Drums

14.15.6.1. The drums shall be of size 800 mm to 1000 mm in height and 300 mm in diameter. They shall be constructed of lightweight, flexible, and deformable materials of LLDP or plastic so that no damage is caused to the vehicle when stuck. Steel drums shall not be used. They may be of bright red, yellow or white colors. They should be portable enough to be shifted from place to place within a temporary traffic control project to accommodate changing conditions but would remain in place for a prolonged period. The markings on drums shall be horizontal, circumferential, alternative orange and white retro-reflective stripes 100 to 150 mm wide. Each drum shall have a minimum of two orange and two white stripes. Any non-retro reflective spaces between the horizontal orange and white stripes, shall not exceed 50 mm wide. Drums shall have closed tops that will not allow collection of roadwork or other debris. When they are used in regions susceptible to freezing, they should have drainage holes in the bottom so that water will not accumulate and freeze, causing a hazard if struck by a motorist. Ballast shall not be placed on top of drum.

14.15.6.2. The measurement shall be for each piece and payment for each piece, for providing and maintenance at site as per the direction of the Engineer.

14.15.7.Barricades:-The barricades may be portable or permanent. Barricades may be of wooden, metal or other suitable material panels. They shall be stable under adverse weather conditions

and appear significant but not to cause damage to the vehicle if they are stuck. They can be classified in 3 types, namely Type-I, Type-II and Type-III. Type-I and Type-II are portable and Type-III permanent. Because of their vulnerable position and the hazard they could create, they should be constructed of lightweight materials and should have no rigid stay bracing for A-frame designs.

14.16. Reflective Clothing's

- 14.16.1.**In the work zones and construction sites, all the workers, supervisors and inspecting officers shall wear high visibility fluorescent clothing's with retro-reflective material, so that their presence is conspicuous from a distance of 300 m. Clothing's may be in form of vests, T-shirts, jackets, pants and raincoats etc., depending upon weather conditions and ease of usage. They shall be of bright colors of fluorescent red-orange or fluorescent yellow green.
- 14.16.2.**The reflective clothing's shall have reflective bands of width appropriate for the garments viz. vests, T-shirts, jackets, pants and raincoats. It shall have 3600 visibility with at least one retro-reflective band encircling the torso, There shall be appropriate separation distances of vertical and horizontal bands placed on torso, sleeves and trouser areas. The garment shall be free of roughness and sharp edges so as not to cause excessive irritation and the wearer should get the best possible degree of comfort and protection.
- 14.16.3.**The reflective clothing shall meet the requirements of standards given in IS:15809-2008 or EN 471:2003 The material shall be tested for color and luminance, color fastness with cracking, perspiration, laundering and UV light exposure. The material shall meet the requirements of brightness after rainfall performance, temperature variation, abrasion resistance, flexing, cold folding and variation in temperature.
- 14.16.4.**Measurement shall be for the unit piece of clothing and payment for providing and maintaining at site as per direction of the Engineer.
- 14.17.** Personal Protection Equipment for Workers All the workers, exposed to moving roadway traffic or equipment in road construction zones shall wear high-visibility safety apparel, headgear, boots, gloves and other protective gears for their protection. The safety apparel shall be in accordance with Clause 813.9. The safety headgear or protective helmet shall protect the wearer against falling objects and possible serious injury. It shall address requirements of shock absorption, resistance to penetration, flame resistance, chin strap anchorages, comfortable wearing and shall meet the requirements of IS: 2925 or EN 397. The safety shoes or boots shall provide personal protection from any possible hazard posed by the activity being done and provide comfortable wearing without giving any hindrance in the expected tasks. The work gloves shall provide protection against any personal injury that could be caused by the activities to be performed and comfort in wearing without giving any hindrance in the expected tasks. If the worker is to be exposed to dust in the work zone, he shall have respiratory protection by dust mask meeting the requirements of IS:9473-2008. Depending upon the task, workers engaged in welding operations shall have eye protection through passive welding sheet meeting the requirements of EN 175 or auto darkening sheet meeting the requirement of EN 379/EN 169.
- 14.18.** Measurement:-The traffic control device of providing traffic signs shall be measured in number. Traffic control devices like barriers and delineators and supply of flagman shall be measured in number and days for which they are used unless specified otherwise in the Contract. Other traffic control devices such as drums, cones, warning tapes, reflective jackets, headgears for workmen shall be considered incidental to the work.
- 14.19.** Rate:-Rate for providing traffic signs shall be inclusive of supply of materials, fabrication,

installation and maintenance of signs. The rate for provision of barriers and delineators shall be on a rental basis per number-days. The rate for supply of flagmen shall be full wages including their reflective jackets and headgear per man-days of deployment.

14.20. Solar Powered Road Markers (Solar Studs)

The solar studs shall be made of Aluminium alloy and poly carbonate material which shall be absolutely weather resistance and strong enough to support a load of 13,635 kg tested in accordance with ASTM D4280, Its colour may be white, red, yellow, green or blue or combination as directed by the Engineer. Its water resistance shall meet the requirements of IP 65 in accordance with IS:12063:1987 Category 2 for protection against water ingress. The dimensions of solar studs shall not be less than 100 mm x 100 mm x 10 mm. It shall have super bright LEDs so as to provide long visibility from a distance of more than 800 m. Its flashing rate shall not be less than 1 Hz. Its should be able to give the prescribed • performance in the temperature range of -40°C to +55°C. Its hi@ shall be not less than 3 years.

14.21. Fixing of Reflective Marker

Requirements

The enveloping profile of the head of the stud shall be smooth and the studs shall not present any sharp edges to traffic. The reflecting portions of the studs shall be free from crevices or ledges where dirt might accumulate. Marker height shall not be less than 10mm and shall not exceed 20 mm. and its width shall not exceed 130 mm. The base of the marker shall be flat within 1.3 mm. If the bottom of the marker is configured, the outermost faces of the configurations shall not deviate more than 1.3 mm from a flat surface, All road studs shall be legibly marked with the name, trade mark or other means of identification of the manufacturer.

14.22. Placement

The reflective marker shall be fiked to the road surface using the adhesives and the procedure recommended by the manufacturer. No nails shall be used to affix the marker so that they do not pose safety hazard on the roads. Regardless of the type of adhesive used, the markers shall not be fixed if the pavement is not surface dry and on new asphalt concrete surfacing until the surfacing 'has been opened to traffic for a period of not less than 14 hours. The portions of the highway surface, to which the marker is to be bonded by the adhesive, shall b9 free of dirt, curing.compohnd, grease, oil, moisture, loose or unsound layers, paint and apyi other material which would adversely affect the bond of the adhesive, The adhesive shall be placed uniformly on the cleaned pavement surface or on the bottom of the of the marker in a quantity sufficient to result in complete coverage of the area of contract of the marker with no voids present and with a slight excess after the marker has been lightly pressed in place. For epoxy installations, excess adhesive around the edge of the marker, excess adhesive on the pavement and adhesive on the exposed surfaces of the markers shall be immediately removed.

14.23. Warranty and durability

The Contractor shall submit a two-year warranty for satisfactory field performance including stipulated retro-reflectance of the reflecting panel, to the Engineer. In addition, a two-year warranty for satisfactory infield performance of the finished road marker shall also be given by the contractor who carries out the work of fixing of reflective road markers. In case the markers' are displaced, damaged, get worn out or lose their reflectivity compared to stipulated standards, the Contractor would be required to replace all such markers within 15 days of the intimation from the Engineer, at his own cost.

14.24. Measurement for Payment

The measurement of reflective road markers shall be in numbers of different types of markers supplied and fixed.

14.25. Rate

The contract unit rate for reflective road markers shall be payment in full compensation for furnishing all labour, material, tools, equipment including incidental costs necessary for carrying out the work at site conforming to the specification complete as per approved drawings or as directed by the Engineer.

15. MATERIAL FOR STRUCTURE (Morth 5th Revision Section-1000)

15.1 General

Materials to be used in the work shall conform to the specifications mentioned on the drawings, the requirements laid down in this section and specifications for relevant items of work. If any material, not covered in these Specifications, is required to be used in the work, it shall conform to relevant Indian Standards, if there are any, or to the requirements specified by the Engineer.

15.2 Sources of materials:-The Contractor shall identify the sources of materials like coarse aggregate and fine aggregate and notify the Engineer regarding the proposed sources prior to delivery. Samples of materials from the source shall be tested in the presence of Engineer for conformity to specifications. It shall also be ensured that the variation in test results of different samples, is within acceptable limits. For manufactured items like cement, steel reinforcement and pre-stressing strands, the contractor shall intimate the Engineer the details of the source, testing facilities available with the manufacturer and arrangements for transport and storage of material at site. If directed by the Engineer, the contractor shall furnish samples and test results of recently received material. The Engineer, at his discretion, in case of doubt, may require the contractor to test the materials in an independent laboratory approved by the Engineer and furnish test certificates. The cost of these tests shall be borne by the contractor. The sampling and testing procedures shall be as laid down in the relevant Indian Standards and where they are not available, the same shall be carried out as per the directions of the Engineer. Only materials from sources approved by the Engineer shall be brought to the site. If the material from the approved source proves unacceptable at any time, the contractor shall identify new sources of acceptable materials conforming to specifications. If any proprietary items are proposed to be used in the works, they shall be governed by the provisions of Clause 115.4 of these Specifications.

15.3 CEMENT:-Cement to be used shall be any of the following types with the prior approval of the Engineer.

a) Ordinary Portland cement, 43 Grade, conforming to 18:8112.

b) Ordinary Portland cement, 53 Grade, conforming to 18:12269.

Cements of 43 and 53 grades conforming to 18:8112 and 18:12269 respectively may be used provided the minimum cement content mentioned elsewhere from durability considerations is not reduced.. Manufacturer's test certificate shall be submitted to the Engineer by the contractor for every consignment of cement. The certificate shall cover all the tests for chemical requirements, physical requirements and chloride content as per relevant codes as applicable. Independent tests of samples drawn from the consignment, shall be carried out at the site laboratory or in an independent laboratory approved by the Engineer, immediately after delivery. The following properties shall be tested: Compressive strength.

ii) Setting time.

The cost of the tests shall be borne by the Contractor. Cement in bags in local storage for more than 3 months after completion of tests, may be re-tested for compressive strength, setting times (initial and final) before use, and may be rejected if it fails to conform to any of the requirements. Lot size for independent testing of cement at site shall be the quantity received at site on any day, subject to a maximum of 500 tonnes.

15.4 Coarse aggregates:- For plain and reinforced cement concrete (PCC and RCC) or pre-

stressed concrete (PSC) works, coarse aggregates shall consist of clean, hard, strong, dense, non-porous and durable pieces of crushed stone, crushed gravel, natural gravel or a suitable combination thereof or other approved inert material. They shall not contain pieces of disintegrated stones, soft, flaky, elongated particles, salt, alkali, vegetable matter or other deleterious materials in such quantities as to reduce the strength and durability of the concrete, or to attack the steel reinforcement. Coarse aggregates having positive alkali-silica reaction shall not be used. All coarse aggregates shall conform to IS: 383 and tests for conformity shall be carried out as per 18:2386, Parts I to VIII. The contractor shall submit for the approval of the Engineer, the entire information indicated in Appendix A of 18:383. Maximum nominal size of coarse aggregate for various structural components in PCC, RCC or P8C, shall conform to Section 1700 of these Specifications.

The maximum value for flakiness index for coarse aggregate shall not exceed 35 percent. The coarse aggregate shall satisfy the requirements of grading as given in Table 1000-1 in Morth 5th revision.

15.5 FINE AGGREGATES:-For masonry work. Sand shall conform to the requirements of IS: 2116. Natural sand. Crushed stone sand or crushed gravel sand or a suitable combination of natural sand. Crushed stone or gravel. Shall be used as fine aggregates in plain. Reinforced and pre-stressed concrete works. The fine aggregates shall be dense. Durable. Clean and free from veins and adherent coating and other deleterious substances. They shall not contain dust. Lumps. Soft or flaky materials. Mica or other deleterious materials in such quantities as to reduce the strength and durability of the concrete. or to attack the embedded steel. Mechanised sand washing machines should be used to remove impurities from sand. Fine aggregates having positive alkali-silica reaction shall not be used. All fine aggregates shall conform to IS:383 and tests for conformity shall be carried out as per IS:2386. (Parts I to VIII). The Contractor shall submit to the Engineer the entire information indicated in Appendix A of IS: 383. The fineness modulus of fine aggregate shall neither be less than 2.0 nor greater than 3.5. Fine aggregate for structural concrete shall conform to the following grading requirements in table 1000-2 in Morth 5th revision.

15.6 Reinforcing Bars:-For plain and reinforced cement concrete (PCC and RCC) or pre-stressed concrete (PSC) works, the reinforcement intentioned steel as the case may be, shall consist of the following grades of reinforcing bars in table 1000-3 (Grades of Reinforcing Bars) in Morth 5th revision. All steel shall be procured from 'Original producers' who manufacture billets directly from iron ores and roll the billets to produce steel conforming to IS: 1786. No re-rolled steel shall be incorporated in the works. However, in case the original producers give certificate that they are unable to supply the steel within the required time or that they are not producing bars of the required diameter, the Engineer may allow the procurement of steel from other suppliers, provided that the reinforcement is manufactured from billets procured from the original producers. In such cases, the manufacturer's certificate alone shall not be considered as sufficient and the steel shall be got tested by the Engineer in the NABL accredited laboratories only, as a third party check. It shall be ensured that all the test results conform to IS: 1786 requirements. Only new steel shall be delivered to the site. Every bar shall be inspected before assembling on the work and defective, brittle or burnt bars shall be discarded. Bars with cracked ends shall be discarded. For the steel procured from original producers also, the Engineer / Employer may carry out occasional checks on materials through third party as mentioned above, for confirming the test results shown in the certificates, in case of any doubt regarding the quality of steel supplied.

15.7 WATER

Water used for mixing and curing shall be clean and free from oils, acids, alkalis, salts, sugar,

organic materials or other Substances that may be deleterious to concrete or steel. In case of doubt regarding development of strength, the suitability of water proposed to be used for the production of concrete shall be ascertained by carrying out tests for the compressive strength of concrete and initial setting time of cement using the same water. The sample of water taken for testing shall represent the water proposed to be used for concreting, taking into account seasonal variations, if any. The sample shall not receive any treatment before testing other than that being given to the regular supply of water proposed for use in concrete. The sample shall be stored in a clean container previously rinsed out with similar water.

Average 28 days compressive strength of at least three 150 mm concrete cubes prepared with water proposed to be used, shall not be less than 90 percent of the average strength of three similar concrete cubes prepared with distilled water. The cubes shall be prepared, cured and tested in accordance with the requirements of IS: 516. The initial setting time of test block made with the appropriate cement and the water proposed to be used shall not be less than 30 minutes and shall not be more than 30 minutes from the initial setting time of control test block prepared with the same cement and distilled water. The test blocks shall be prepared and tested in accordance with the requirements of IS: 4031 (Part 5). PH value of water shall not be less than 6. Potable water is generally considered satisfactory for mixing concrete. Mixing and curing with sea water shall not be permitted. As a guide, the following concentrations represent the maximum permissible values:

- a) To neutralize 100 ml sample of water, using phenolphthalein as an indicator, it should not require more than 5 ml of 0.02 normal NaOH. For details of test refer IS: 3025(Part 22).
- b) To neutralize 100 ml sample of water, using mixed indicator, it should not require more than 25 ml of 0.02 normal. H₂S₀₄

For details of test refer IS: 3025(Part 23).

15.8 CONCRETE ADMIXTURES

15.8.1 General

Admixtures may be added to the concrete before or during mixing with a view to modifying one or more of the properties of concrete in the plastic or hardened state.

15.8.2 Mineral Admixtures:-Any of the following mineral admixtures may be used with the approval of the Engineer.

Fly ash: conforming to of IS: 3812-3

Granulated slag: Ground granulated slag obtained by grinding granulated slag conforming to 18:12089.

Silica fume: Silica fume is very fine, non- crystalline Si₀₂, obtained as a by-product of Silicon and Ferro - Silicon alloy industries and shall conform to 18:15388

15.8.3 Chemical Admixtures

15.8.3.1 Information required from the Manufacturer:-Chemical admixtures are proprietary items of manufacture and shall be obtained only from established manufacturers with proven track record, quality assurance and full-fledged laboratory facilities for the manufacture and testing of concrete. The contractor shall provide the following information concerning each admixture, after

obtaining the same from the manufacturer:

- (a) Normal dosage and detrimental effects, if any, of under dosage and over dosage.
- (b) The chemical names of the main ingredients.
- (c) The chloride content, if any, expressed as a percentage by weight of the admixture.
- (d) Values of dry material content, ash content and relative density which can be used for Uniformity Tests.
- (e) Whether it leads to the entrainment of air when used as per the manufacturer's recommended dosage, and if so to what extent.
- (f) Confirmation regarding its compatibility with type of cement.
- (g) Whether it increases the risk of corrosion of reinforcement or other embedments.
- (h) Whether it affects the durability of concrete adversely.
- (i) Whether it leads to the entrainment of air when used as per the manufacturer's recommended dosage, and if so to what extent.
- (j) Confirmation regarding its compatibility with type of cement.
- (k) Whether it increases the risk of corrosion of reinforcement or other embedment's.
- (l) Whether it affects the durability of concrete adversely.

15.8.3.2 Physical and Chemical Requirements:-Admixtures shall conform to the requirements of IS: 91 03. In addition, the following conditions shall be satisfied.

- a) Plasticizers" and "Super-Plasticizers" shall meet the requirements indicated for "Water reducing Admixture".
- b) Except where resistance to freezing and thawing and to disruptive action of deicing salts is required, the air content of freshly mixed concrete in accordance with the pressure method given in IS: 1199, shall not be more than 2 percent higher than that of the corresponding control mix and in any case not more than 3 percent of the test mix.
- c) The chloride content of the admixtures shall not exceed 0.2 percent when tested in accordance with IS: 6925. In addition, the maximum permissible limit of chloride content of all the constituents as indicated in Section 1700 of these Specifications shall also not be exceeded.
- d) Uniformity tests on the admixtures are essential to compare qualitatively the composition of different samples taken from batch to batch or from the same batch at different times.

The tests that shall be performed along with permissible variations are as follows:

- i) Dry Material Content: within 3 percent and 5 percent of liquid and solid
- ii) Ash content: within 1 percent of the value stated by the manufacturer.
- iii) Relative Density (for liquid admixtures): within 2 percent of the value stated by the manufacturer.
- e) All tests relating to concrete admixtures shall be conducted periodically at an independent laboratory and the results compared with the data given by the manufacturer.

15.8.4 Cement:-Cement shall be transported, handled and stored on the site in such a manner as to avoid deterioration or contamination. Cement shall be stored above ground level in perfectly dry and water-tight sheds and shall be stacked to a height of not more than eight bags. Wherever bulk storage containers are used, their capacity should be sufficient to cater to the requirement at site. The containers shall be cleaned at least once every 3 months. Cement shall be used in the sequence in which it is delivered at site. Each consignment shall be stored separately so that it may be readily

identified and inspected. Any consignment or part of a consignment of cement which has deteriorated in any way during storage, shall not be used in the works and shall be removed from the site by the Contractor at his own cost. The Contractor shall prepare and maintain proper records at site in respect of delivery, handling, storage and use of cement and these records shall be available for inspection by the Engineer at all times. The Contractor shall submit a monthly return to the Engineer showing the quantities of cement received and issued during the month and in stock at the end of the month.

15.8.5 Reinforcement/un-tensioned Steel:- The reinforcement bars, shall be stored above the surface of the ground upon platforms, skids or other supports, and shall be protected from mechanical injury and from deterioration by exposure.

16. STRUCTURAL CONCRETE (Morth 5th Revision Section-1700)

16.1 Description:-The work shall consist of producing, transporting, placing and compacting of structural concrete including fixing formwork and temporary works etc. and incidental construction in accordance with these Specifications and in conformity with the lines, grades and dimensions, as shown on the drawings or as directed by the Engineer.

16.2 MATERIALS:-All materials shall conform to Section 1000 of these Specifications.

16.3 GRADES OF CONCRETE

16.3.1 The grades of concrete shall be designated by the characteristic strength as given in Table 1700-1, where the characteristic strength is defined as the strength of concrete below which not more than 5 percent of the test results are expected to fall in **table 1700-1 (Grades of Concrete) in Morth 5th revision.**

1) Normal Mix Concrete is made on the basis of nominal mix proportioned by weight of its main ingredients - cement, coarse and fine aggregates and water.

2) Standard concrete is made on the basis of design mix proportioned by weight of its ingredients, which in addition to cement, aggregates and water, may contain chemical admixtures to achieve certain target values of various properties in fresh condition, achievement of which is monitored and controlled during production by suitable tests. Generally, concrete of grades up to M50 are included in this type.

3) High Performance Concrete is similar to standard concrete but contains additional one or more mineral admixtures providing binding characteristics and partly acting as inert filler material which increases its strength, reduces its porosity and modifies its other properties in fresh as well as hardened condition. Concrete of grades up to M90 are included in this type.

4) For concrete of grades higher than M90, the design parameters may be obtained from specialized literature and experimental results.

16.3.2 The minimum grades of concrete and corresponding minimum cement content and maximum water/cement ratios for different exposure conditions shall be as indicated in Table 1700-2(Morth 5th Revision).

16.3.3 For concrete subjected to sulphate attack the minimum grades of concrete, minimum cement content and maximum water/cement ratios and types of cement for different concentration of sulphate content shall be as indicated in Table 1700-3.PI referred table 1700-2 ; Requirement of Concrete for Different Exposure Condition using 20 mm Aggregate in Morth 5th revision.

16.4 Proportioning of concrete:- Prior to the start of construction, the Contractor shall design the mix in case of design mix concrete or propose nominal mix in case of nominal mix concrete, and submit to the Engineer for approval, the proportions of materials, including admixtures to be used. Water-reducing admixtures (including plasticizers or super-plasticizers) may be used at the Contractor's option, subject to the approval of the Engineer.

16.4.1 Requirements of Consistency:-The mix shall have the consistency which will allow proper placement and compaction in the required position. Every attempt shall be made to obtain uniform consistency. Slump test shall be used to measure consistency of the concrete. The optimum consistency for various types of structures shall be as indicated in Table 1700-4, or as directed by the Engineer. The slump of concrete shall be checked as per IS: 516. PI refereed Table 1700-4:

Requirements of Consistency in Morth 5th revision. Notwithstanding the optimum consistency indicated against SI. No.1 to 3, the situation should be properly assessed to arrive at the desired workability with the adjustment of admixture in each case, where the concrete is to be transported through transit mixer and placed using concrete pump. Under these circumstances, the optimum consistency during placement for the items of work of SI. No.1 to 3, can be considered ranging from 75 mm to 150 mm. This is, however, subject to satisfying the other essential criteria of strength, durability etc. and approval of the Engineer.

16.4.2 Requirements for Design Mixes

16.4.2.1 Target Mean Strength:-The target mean strength of specimen shall exceed the specified characteristic compressive strength by at least the current margin.

- i) The current margin for a concrete mix shall be determined by the Contractor and shall be taken as 1.64 times the standard deviation of sample test results taken from at least 40 separate batches of concrete of nominally similar proportions produced at site by the same plant under similar supervision, over a period exceeding 5 days, but not exceeding 6 months.
- ii) Where there is insufficient data to satisfy the above, the current margin for the initial design mix shall be taken as given in Table 1700-5: PI referred Table 1700-5 : Current Margin for Initial Design Mix in Morth 5th revision. The initial current margin given in Table 1700-5 shall be used till sufficient data is available to determine the current margin as per Sub-Clause 1704.2.1 (i).

16.4.2.2 Trial Mixes:-The Contractor shall give notice to the Engineer to enable him to be present at the time of carrying out trial mixes and preliminary testing of the cubes. Prior to commencement of trial mix design, all materials forming constituents of proposed design mix should have been tested and approval obtained in writing from the Engineer. Based on test results of material, draft mix design calculation for all grades of concrete to be used in the works, shall be prepared after taking into account the provisions in the Contract Technical Specifications, Guidelines of IS:10262, IS:SP:23 and IRC:112 and submitted to the Engineer for approval.

Prior to commencement of concreting, trial mix design shall be performed for all grades of concrete and trial mix which has been found successful, shall be submitted by the Contractor and approval obtained. During concreting with the approved trial mix design, if source of any constituents is changed, the mix design shall be revised and tested for satisfying the strength requirements.

The initial trial mixes shall be carried out in a laboratory approved by the Engineer. However, Engineer may permit the initial trial mixes to be prepared at the site laboratory of the Contractor, if a full-fledged concrete laboratory has been established well before the start of construction, to his entire satisfaction. Sampling and testing procedures shall be in accordance with these Specifications. When the site laboratory is utilized for preparing initial mix design, the concrete production plant and means of transport employed to make the trial mixes shall be similar to those proposed to be used in the works. For each trial mix, a set of six cubes shall be made from each of three consecutive batches for purposes of testing. Three cubes from each set of six shall be tested at an age of 28 days and three at an earlier age approved by the Engineer. The cubes shall be made, cured, stored, transported and tested in accordance with these Specifications. The mean strength of the nine cubes at 28 days shall exceed the specified characteristic strength by the current margin minus 3.5 MPa.

16.4.2.3 Control of Strength of Design Mixes:

a) Adjustment to Mix Proportions:-Adjustment to mix proportions arrived at in the trial mixes, shall be made subject to the Engineer's approval, in order to minimize the variability of strength and to maintain the target mean strength. Such adjustments shall not be taken to imply any change in the current margin.

b) Change of Current Margin When required by the Engineer, the Contractor shall recalculate the current margin in accordance with Clause 1704.2.1. The recalculated value shall be adopted as directed by the Engineer, and it shall become the current margin for concrete produced thereafter.

c) Additional Trial Mixes In case any changes are observed in the properties of fresh concrete and/or strength of hardened concrete on the basis of early age tests, additional mixes and tests shall be carried out during production, so as to control and bring the quality of concrete within acceptable limits. In case of any change in the source or properties of materials, the design of mix shall be established afresh. Value shall be adopted as directed by the Engineer, and it shall become the current margin for concrete produced thereafter.

16.5 Requirements of Nominal Mix Concrete

Requirements for nominal mix concrete unless otherwise specified shall be as given in Table 1700-6. Pl refered Table 1700-6 : Requirements for Nominal Mix Concrete in Morth 5th revision.

16.6 Additional Requirements:-Concrete shall meet any other requirements as specified on the drawing or as directed by the Engineer. The overall limits of deleterious substances in concrete shall be as follows:

a) Total acid soluble chloride content in the concrete mix expressed as chloride ions shall not exceed the following values by mass of cement. Pre-stressed concrete 0.1% Reinforced Concrete (in severe, very severe or extreme exposure condition) 0.2% Reinforced concrete in moderate exposure condition 0.3%

b) The total water soluble sulphate content of the concrete mix expressed as SO₃' shall not exceed 4 percent by mass of cement in the mix. For concrete made with Portland pozzolona cement, Portland blast furnace slag cement or mineral admixtures, the setting time and rate of gain of strength are different from those for concrete made with OPC alone. Such modified properties shall be taken into account while deciding the de-shuttering time, curing period, early age loading and time of pre-stressing. Additional cube samples may be required to be taken for verifying the concrete properties.

16.7 Suitability of Proposed Mix Proportions

The Contractor shall submit the following information for the Engineer's approval:

a) Nature and source of each material

b) Quantities of each material per cubic metre of fully compacted concrete

c) Either of the following:

i) Appropriate existing data as evidence of satisfactory previous performance for the target mean strength, current margin, consistency and water/cement ratio and any other additional requirement as specified.

ii) Full details of tests on trial mixes.

d) Statement giving the proposed mix proportions for nominal mix concrete

Any change in the source of material or in the mix proportions shall be subject to the Engineer's prior approval.

16.8 Checking of Mix Proportions and Water/Cement Ratio:-In proportioning concrete, the quantity of both cement and aggregate shall be determined by weight. Where the weight of cement per bag as given by the manufacturer is accepted, a reasonable number of bags shall be weighed separately to check the net weight. Where cement is weighed from bulk stock at site and not by bag, it shall be weighed separately from the aggregates. Water shall either be measured by volume in calibrated tanks or weighed. All measuring equipment shall be maintained in a clean and serviceable condition. Their accuracy shall be periodically checked. The specified water/cement ratio shall always be kept constant and at its correct value. To this end, moisture content in both fine and coarse aggregates shall be determined as frequently as possible, the frequency for a given job being determined by the Engineer according to the weather conditions. The amount of water to be added shall then be adjusted to compensate for variations in the moisture content. For the determination of moisture content in the aggregates IS:2386 (Part III) shall be referred. Suitable adjustments shall also be made in the weight of aggregates to allow for their variation in weight due to variation in their moisture content.

16.9 ADMIXTURES

16.9.1 Chemical Admixtures:-Chemical admixtures such as superplasticizers, or air entraining, water reducing, accelerating and retarding agents for concrete, may be used with the approval of the Engineer. As the selection of an appropriate concrete admixture is an integral part of the mix design, the manufacturers shall recommend the use of anyone of their products only after obtaining complete information of all the actual constituents of concrete as well as methodologies of manufacture, transportation and compaction of concrete proposed to be used in the work. Admixtures/additives conforming to IS:91 03 may be used subject to approval of the Engineer. However, admixtures/additives generating hydrogen or nitrogen and containing chlorides, nitrates, sulphate, sulphate or any other material likely to adversely *affect* the steel or concrete, shall not be permitted. The general requirements for admixtures are given in Clause 1007 of these Specifications. Compatibility of the admixtures with the cement and any other pozzolona or hydraulic addition shall be ensured by for avoiding the following problems

- i) Requirement of large dosage of superplasticizer for achieving the desired workability,
- ii) Excessive retardation of setting,
- iii) Excessive entrainment of large air bubbles,
- iv) Unusually rapid stiffening of concrete,
- v) Rapid loss of slump
- vi) Excessive segregation and bleeding.

16.10 Batching, mixing, transporting, placing and compaction

16.10.1 General:-Prior to start of concreting, the Contractor shall submit for approval of the Engineer, his programme along with list of equipment proposed to be used by him for batching, mixing, transporting and placing concrete.

16.10.2 Batching of Concrete:-In batching concrete:

- (a) **The quantity of cement, aggregate** and mineral admixtures, if used, shall be determined

by mass.

- (b) **Chemical admixtures, if solid, shall be determined by mass. Liquid admixtures may be measured in volume or mass, and Water shall be weighed or measured by volume in a calibrated tank.**

The concrete shall be sourced from on-site or off-site batching and mixing plants, or from approved Ready Mixed Concrete plants, preferably having quality certification. Except where supply of properly graded aggregate of uniform quality can be maintained over a period of work, the grading of aggregate should be controlled by obtaining the coarse aggregate in different sizes and blending them in the right proportions when required, the different sizes being stocked in separate stock piles. The materials should be stock piled several hours, preferably a day before use. The grading of coarse and fine aggregate should be checked as frequently as possible to ensure that the specified grading is maintained. The water/cement ratio shall always be maintained constant at its correct value. To this end, determination of moisture content in both fine and coarse aggregates shall be made as frequently as possible, depending on weather conditions. The amount of added water shall be adjusted to compensate for any observed variations in the moisture content. To allow for the variation in mass of aggregate due to variation in moisture content, suitable adjustment in the mass of aggregate, shall also be made. Accurate control shall be kept on the quantity of mixing water, which when specified, shall not be changed without approval.

16.10.3 Mixing Concrete

16.10.3.1 Mixing at Site:-All concrete shall be machine mixed. In order to ensure uniformity and good quality of concrete the ingredients shall be mixed in a power driven batch mixer with hopper and suitable weigh batching arrangement or in a central mix plant. Hand mixing shall not be permitted. The mixer or the plant shall be at an approved location considering the properties of the mixes and the transportation arrangements available with the Contractor. The mixer or the plant shall be approved by the Engineer. Mixing shall be continued till materials are uniformly distributed, a uniform color of the entire mass is obtained and each individual particle of the coarse aggregate shows complete coating of mortar containing its proportionate amount of cement. In no case shall mixing be done for less than 2 minutes. It shall be ensured that the mixers are not loaded above their rated capacities and are operated at a speed recommended by the manufacturer. When mineral admixtures are added at the mixing stage, their thorough and uniform blending with cement shall be ensured, if necessary by longer mixing time. The addition of water after the completion of the initial mixing operation, shall not be permitted. Mixers which have been out of use for more than 30 minutes shall be thoroughly cleaned before putting in a new batch and also before changing from one type of cement to another.

16.10.3.2 Ready Mix Concrete:-Use of ready mix concrete proportioned and mixed off the project site and delivered to site in a freshly mixed and unhardened state conforming to IS: 4926, shall be allowed with the approval of the Engineer.

16.10.4 Transporting Concrete:-Mixed concrete shall be transported from the place of mixing to the place of final deposit as rapidly as possible by methods which will prevent the segregation or loss of the ingredients. The method of transporting or placing of concrete shall be approved by the Engineer. Concrete shall be transported and placed as near as practicable to its final position so that no contamination, segregation or loss of its constituents materials take place. Concrete may be transported by transit mixers or properly designed buckets or by pumping. Transit mixers or other hauling equipment when used should be equipped with the means of discharge of concrete without segregation. During hot or cold weather, concrete shall be transported in deep containers. Other

suitable methods to be reduce the loss of water by evaporation in hot weather and heat loss in cold weather may also be adopted when concrete is conveyed by chute, the plant shall be of such size and design as to ensure practically continuous flow. Slope of the chute shall be so adjusted that the concrete flows without excessive quantity of water and without any segregation of its ingredients. The delivery end of the chute shall be as close as possible to the point of deposit. The chute shall be thoroughly flushed with water before and after each working period and the water used for this purpose shall be discharged outside the formwork. In case concrete is to be transported by pumping, the fresh concrete should have adequate fluidity and cohesiveness to be pump able. Proper concrete mix proportioning and initial trials should ensure this. The conduit shall be primed by pumping a batch of mortar through the line to lubricate it. Once the pumping is started, it shall not be interrupted, as concrete standing idle in the line is liable to cause plug. The operator shall ensure that some concrete is always there in the pump's receiving hopper during operation. The lines shall always be maintained clean and free of dents.

Pipelines from the pump to the placing area shall be laid with minimum bends. For large quantity placements, standby pumps shall be available. Suitable air release valves, shutoff valves etc. shall be provided as per site requirements. The pumping of priming mix i.e. rich mix of creamy consistency, to lubricate the concrete pump and pipelines, shall precede the pumping of concrete. Continuous pumping shall be done to the extent possible. After concreting, the pipelines and accessories shall be cleaned immediately. The pipes for pumping shall not be made of material which has adverse effect on concrete. Aluminium alloy pipelines shall not be used.

16.10.5 Placing of Concrete:-All formwork and reinforcement contained in it shall be cleaned and made free from standing water, dust, snow or ice immediately before placing of concrete. No concrete shall be placed in any part of the structure until the approval of the Engineer has been obtained. If concreting is not started within 24 hours of the approval being given, the approval shall have to be obtained again from the Engineer. Concreting shall proceed continuously over the area between the construction joints. Fresh concrete shall not be placed against concrete which has been in position for more than 30 minutes, unless a proper construction joint is formed. The concrete shall be deposited as nearly as practicable in its original position to avoid re handling. Methods of placing should be such as to preclude segregation. Care should be taken to avoid displacement of reinforcement or movement of formwork. To achieve this, concrete should be lowered vertically in the form and horizontal movement of concrete inside the forms should, as far as practicable, be minimized. The concrete shall be placed and compacted before its initial setting so that it is amenable to compaction by vibration. The workability of concrete at the time of placement shall be adequate for the compaction equipment to be used. If there is considerable time gap between mixing and placing of concrete, as in the case of ready mixed concrete plants or off-site batching and mixing plants, concrete mix shall be designed to have appropriately higher workability at the time of discharge from the mixer, in order to compensate the loss of workability during transit. This is generally achieved by suitable chemical admixtures. Keeping these considerations in view, the general requirement for ready mixed concrete plants or off-site batching and mixing plants, is that concrete shall be discharged from the truck mixer within two hours of the time of loading. A longer period may be permitted if suitable retarding admixtures are used. In wall forms, drop chutes attached to hoppers at the top should preferably be used to lower concrete to the bottom of the form. As a general guidance, the permissible free fall of concrete may not exceed 1.5 meters and under no circumstances shall it be more than 2 meters. When free fall of larger height is involved, self-compacting concrete having adequate fluidity, cohesiveness and viscosity and which uniformly and completely fills every corner of the formwork by its own weight without segregation, shall be used. Except where otherwise agreed to by the Engineer, concrete shall be

deposited in horizontal layers to a compacted depth of not more than 450 mm when internal vibrators are used and not more than 300 mm in all other cases. Concrete when deposited shall have temperature of not less than 5°C and preferably not more than 30°C and in no case more than 40°C. In case of site mixing, fresh concrete shall be placed and compacted in its final position within 30 minutes of its discharge from the mixer. When the concrete is carried in properly designed agitator operating continuously, the concrete shall be placed and compacted within 1 hour of the addition of cement to the mix and within 30 minutes of its discharge from the agitator. It may be necessary to add retarding admixtures to concrete, if trials show that the periods indicated above are unacceptable. In all such matters, the Engineer's decision shall be final.

16.10.6 Compaction of Concrete:-Concrete shall be thoroughly compacted by vibration or other means during placing and worked around the reinforcement, tendons or duct formers, embedded fixtures and into corners of the formwork to produce a dense homogeneous void-free mass having the required surface finish. When vibrators are used, vibration shall be done continuously during the placing of each batch of concrete until the expulsion of air has practically ceased and in a manner that does not promote segregation. Over-vibration shall be avoided to minimize the risk of forming a weak surface layer. When external vibrators are used, the design of formwork and disposition of vibrator shall be such as to ensure efficient compaction and to avoid surface blemishes. Vibrations shall not be applied through reinforcement and where vibrators of immersion type are used, contact with reinforcement and all inserts like ducts etc., shall be avoided.

When internal vibrators are used, they shall be inserted vertically to the full depth of the layer being placed and ordinarily shall penetrate the layer below for a few centimeters. The vibrator should be kept in place until air bubbles cease escaping from the surface and then withdrawn slowly to ensure that no hole is left in the concrete, care being taken to see that it remains in continued operation while being withdrawn. The internal vibrators shall be inserted in an orderly manner and the distance between insertions should be about one and half times the radius of the area visibly affected by vibration. Additional vibrators in serviceable condition shall be kept at site so that they can be used in the event of breakdown. Mechanical vibrators used shall comply with 18:2502, 18:2506, 18:2514 and 18:4656.

16.11 PROTECTION AND CURING

16.11.1 General:-Concreting operations shall not commence until adequate arrangements for concrete curing have been made by the Contractor. Curing and protection of concrete shall start immediately after compaction of the concrete. The concrete shall be protected from:

- a) Premature drying out particularly by solar radiation and wind
- b) High internal thermal gradients
- c) Leaching out by rain and flowing water
- d) Rapid cooling during the first few days after placing
- e) Low temperature or frost
- f) Vibration and impact which may disrupt the concrete and interfere with its bond to the reinforcement.
- g) Vibration caused by traffic including construction traffic. Concrete shall be protected, without allowing ingress of external water, by means of wet (not dripping) gunny bags, hessian etc. Once the concrete has attained some degree of hardening (approximate 12 hrs. after mixing), moist

curing shall commence and be continued through the requisite period. Where members are of considerable size and length, with high cement content, accelerated curing methods may be applied, as approved by the Engineer.

16.11.2 Water Curing:-Water for curing shall be as specified in **Section 1000** of these specifications. Sea water shall not be used for curing. Sea water shall not come into contact with concrete members before they have attained adequate strength. The concrete should be kept constantly wet by ponding or covering or use of sprinklers/ perforated pipes for a minimum period of 14 days after concreting, except in the case of concrete with rapid hardening cement, where it can be reduced to 5 days. Water should be applied on surfaces after the final set. Curing through watering shall not be done on green concrete. On formed surfaces, curing shall start immediately after the forms are stripped. The concrete shall be kept constantly wet with a layer of sacking, canvas, hessian or similar absorbent material.

16.12 Finishing:-Immediately after the removal of forms, exposed bars or bolts, if any, shall be cut inside the concrete member to a depth of at least 50 mm below the surface of the concrete and the resulting holes filled with cement mortar. All fins caused by form joints, all cavities produced by the removal of form ties and all other holes and depressions, honeycomb spots, broken edges or corners, and other defects, shall be thoroughly cleaned, saturated with water and carefully pointed and rendered true with mortar. The mortar shall be of cement and fine aggregate mixed in the proportions used in the grade of concrete that is being finished and of as dry a consistency as possible. Considerable pressure shall be applied in filling and pointing to ensure thorough filling in all voids. Surfaces which have been pointed shall be kept moist for a period of twenty four hours. Special pre-packaged proprietary mortars shall be used where appropriate or where specified in the drawing.

All construction and expansion joints in the completed work shall be left carefully tooled and free from any mortar and concrete. Expansion joint filler shall be left exposed for its full length with clean and true edges. Immediately on removal of forms, the concrete work shall be examined by the Engineer before any defects are made good. The work that has sagged or contains honeycombing to an extent detrimental to structural safety or architectural appearance of the member, shall be rejected. Surface defects of a minor nature may be accepted. On acceptance of such work, the same shall be rectified as directed by the Engineer.

16.13 Concrete with blended cements or mineral admixtures

16.13.1 Production of Concrete:-In order to improve the durability of the concrete, use of blended cement or blending of mineral admixtures, is permitted. The maximum limit of fly ash

and ground granulated blast furnace slag in concrete, shall be as specified in Clause 1715.2. Blending at site shall be permitted only through a specific facility with complete automated process control to achieve the specified design quality or through RMC plants with similar facility.

16.13.2 Modified Properties:-For concrete made with Portland Pozzolona Cement, Portland Blast furnace slag cement or mineral admixtures, the setting time and rate of gain of strength are different from those of concrete made with OPC alone. Cognizance of such modified properties shall be taken in deciding de-shuttering time, initial time of pre-stressing, curing period and for early age loading.

16.13.3 Compatibility of Chemical Admixtures:-Compatibility of chemical admixtures and superplasticizers with Portland Pozzolona cement, Portland blast furnace slag cement and mineral

admixtures shall be ensured by trials outlined in Clause 1705.

16.13.4 Additional Tests:-In addition to the strength tests prescribed in other Sections of these Specifications, the following additional tests are required to be carried out from considerations of durability.

i) Rapid Chloride Ion Permissibility Test:-Rapid Chloride Ion permeability test on as per ASTM C 1202 at 56 days for extreme, very severe and severe conditions of exposure. The permissible value of Chloride-Ion permeability for extreme condition 800 Coulombs very severe condition 1200 coulombs and severe exposure condition 1500 coulombs.

ii) Water Permeability Test:-Water permeability test as per DIN: 1048 Part 5-1991 shall be carried out as described in Clause 1717.2.5.5

16.14 TESTS AND STANDARDS OF ACCEPTANCE

16.14.1 Concrete shall conform to the surface finish and tolerance as prescribed in these Specifications for respective components.

16.14.2 Random sampling and lot by lot acceptance inspection, shall be made for the 28 days cube strength of concrete.

16.14.3 Concrete under acceptance, shall be notionally divided into lots for the purpose of sampling before commencement of work. The basis of delimitation of lots shall be as follows:

- i) No individual lot shall be more than 30 cum in volume
- ii) Different grades of mixes of concrete shall be divided into separate lots.
- iii) Concrete of a lot shall be used in the same identifiable component of the bridge.

16.14.4 Sampling and Testing:-Concrete for preparing 3 test cubes shall be taken from a batch of concrete at point of delivery for construction, according to procedure laid down in IS:1199. A random sampling procedure shall be adopted which ensures that each of the concrete batches forming the lot under acceptance inspection has equal chance of being chosen for taking cubes. 150 mm cubes shall be made, cured and tested at the age of 28 days for compressive strength in accordance with IS: 516. The 28 day test strength result for each cube shall form an item of the sample. Tests at other age shall also be performed, if specified. Where automated batching plant/Ready Mixed Concrete Plant is located away from the place of use and the time gap between production and placement is more than the initial setting time or where any ingredients are added subsequent to mixing, separate sets of samples shall be collected and tested at batching plant and at location of placement. The results shall be compared and used to make suitable adjustment at batching plants so that properties of concrete at placement are as per the requirements.

16.14.5 Test Specimen and Sample Strength:-Three test specimens shall be made from each sample for testing at 28 days. Additional cubes may be required for various purposes such as to determine the strength of concrete at 7 days or for any other purpose. The test strength of the sample shall be the average of the strength of 3 cubes. The individual variation should not be more than ± 15 percent of the average. If variation is more, the test results of the sample are invalid.

16.14.6 Frequency:-The minimum frequency of sampling of concrete of each grade shall be in accordance with Table 1700-9(as Per Morth 5th revision).

16.14.7 Acceptance criteria

16.14.7.1 Compressive Strength

1) **Cubes:-**The concrete shall be taken as having the specified compressive strength when both the following conditions are met:

- a) The mean strength determined from any group of four consecutive non-overlapping samples exceeds the specified characteristic compressive strength by 3 MPa.
- b) Strength of any sample is not less than the specified characteristic compressive strength minus 3 MPa. The quantity of concrete represented by the test results include the batches from which the first and last samples were taken, together with all intervening batches.

2) **Cores:-**When the concrete does not satisfy both the conditions given in (1) above, representative cores shall be extracted from the hardened concrete for compression test in accordance with the method described in IS: 1199 and tested to establish whether the concrete satisfies the requirement of compressive strength. Evaluation of compressive strength by taking cores may also be done in case of doubt regarding the grade of concrete used either due to poor workmanship or based on results of cube strength tests. The locations from which core samples are to be taken and their number shall be decided so as to be representative of the whole of the concrete under consideration. However, in no case shall fewer than three cores be tested. Cores shall be prepared and tested as described in IS: 516. Concrete in the member represented by a core test shall be considered acceptable if the average equivalent cube strength of the cores is equal to at least 85 percent of the cube strength of the grade of concrete specified for the corresponding age and no individual core has strength less than 75 percent of the specified strength.

16.14.7.2 Density of Fresh Concrete:-Where minimum density of fresh concrete is specified, the mean of any four consecutive non-overlapping samples shall not be less than the specified value and any individual sample result shall not be less than 97.5 percent of the specified value.

16.14.7.3 Density of Hardened Concrete:-Where minimum density of hardened concrete is specified, the mean of any four consecutive non-overlapping samples shall not be less than the specified value and any individual sample result shall not be less than 97.5 percent of the specified value.

16.14.7.4 Permeability Test:-Water permeability test as per DIN: 1048 Part 5-1991 shall be carried out as described below:

- i) A cylindrical test specimen 150 mm dia. and 160 mm high shall be prepared.
- ii) After 28 days of curing, the test will be conducted between 28 and 35 days. The test specimen shall be fitted in a machine such that specimen can be subjected to a water pressure of up to 7 bars. A typical machine is shown in Appendix-1700/1.
- iii) The concrete specimen shall be subjected to a water pressure of 0.5 N/mm^2 from the top for a period of 3 days. The pressure shall be maintained constant throughout the test period. If the water penetrates through to the underside of the specimen, the test may be terminated and the specimen rejected as failed.
- iv) After 3 days, the pressure shall be released and the sample shall be taken out. The specimen shall be split in the middle by compression applied on two round bars on opposite sides above and below.
- v) When the split faces show signs of drying (after 5 to 10 minutes), the maximum depth of

penetration in the direction of height shall be measured with the scale and extent of water penetration established.

vi) The mean of maximum depth of penetration obtained from three specimens thus tested, shall be taken as the test result and it shall not exceed 25 mm.

16.14.7.5 If the concrete is not able to meet any of the standards of acceptance as prescribed, the effect of such deficiency on the structure shall be investigated by the Contractor as directed by the Engineer. The Engineer may accept the concrete as sub-standard work. Any additional work required by the Engineer for such acceptance, shall be carried out by the Contractor at his cost. In case the concrete is not found to be acceptable even after investigation, the Contractor shall remove the rejected concrete forthwith.

16.14.7.6 When durability of concrete is desired the rapid chloride ion permeability test as stated under Clause 1714.3.1 shall also be performed in addition to above tests.

16.15 MEASUREMENTS FOR PAYMENT:-Structural concrete shall be measured in cubic meters. In reinforced or pre-stressed concrete, the volume occupied by reinforcement or pre-stressing cables and sheathing shall not be deducted. The slab shall be measured as running continuously through and the beam as the portion below the slab.

16.16 RATE:-The contract unit rate for structural concrete shall cover costs of all materials, labour, tools, plant and equipment required for mixing, transporting and placing in position, vibrating and compacting, finishing and curing as per this Section or as directed by the Engineer, including all incidental expenses, sampling and testing, quality assurance and supervision. Unless mentioned separately as an item in the contract, the contract unit rate for concrete shall also include the cost of providing, fixing and removing formwork required for concrete work as per

Section 1500 of these Specifications. If the concrete is found to be acceptable by the Engineer as sub-standard work, the Contractor shall be subjected to reduction in his contact unit rate. For deficiency in compressive strength of concrete when accepted by the Engineer, the reduction in rate shall be applied as under:

Percentage reduction in rate = $((\text{Design Strength} - \text{Observed Strength}) / \text{Design Strength}) \times 100$

17.1. TECHNICAL SPECIFICATIONS FOR UTILITY WORK. LIST OF BUREAU OF INDIAN STANDARDS (BIS) CODES

Table 1

S. No.	IS No.	Subject
1.	IS 458	Pre-cast Concrete Pipes (with and without reinforcement).
2.	IS 651	Specification for Salt Glazed Stoneware Pipes and Fittings.
3.	IS 783	Code of Practice for Laying Concrete Pipes
4.	IS 1726	Specification for Cast Iron Manhole Covers and Frames
5.	IS 1729	Cast Iron /Ductile Iron Drainage Pipes and Pipe Fittings Socket and Spigot Series for Over-ground Non-pressure Pipe Line.
6.	IS 4127	Code of Practice for Laying of Glazed Stone Ware Pipes
7.	IS 4885	Specifications for Sewer Bricks
8.	IS 12592	Pre-cast Concrete Manhole Covers and Frames – Specifications

17.1 CEMENT CONCRETE PIPES (WITH AND WITHOUT REINFORCEMENT)

The pipes shall be with or without reinforcement as required and shall be of class not lesser than NP2. These shall conform to IS 458 and shall be capable of withstanding a test pressure of 0.07 MPa (7 m head). The reinforced cement concrete pipes shall be manufactured by centrifugal (or spun) process while un-reinforced cement concrete pipes by spun or pressure process. All pipes shall be true to shape, straight, perfectly sound and free from cracks and flaws. The external and internal surface of the pipes shall be smooth and hard. The pipes shall be free from defects resulting from imperfect grading of the aggregate mixing or molding.

Concrete used for the manufacture of un-reinforced and reinforced concrete pipes and collars shall not be leaner than 1:2:4 (1 cement: 2 coarse sand: 4 graded stone aggregate). The maximum size of aggregate should not exceed one third of the thickness of the pipe or 20 mm whichever is smaller for pipes above 250 mm internal diameter. But for pipes of internal diameter 80 to 250 mm, the maximum size of aggregate should be 10mm. The reinforcement in the reinforced concrete pipes shall extend throughout the length of the pipe. The circumferential and longitudinal reinforcements shall be adequate to withstand the specified hydrostatic pressure and further bending stresses due to the weight of water when running full across a span equal to the length of pipe plus three times its own weight.

The dimensional requirements of concrete pipes are given in Appendix I.

The minimum clear cover for reinforcement in pipes and collars shall be as given in Table 19.3.

Table 2

Sl. No.	Precast concrete pipe/collar	Minimum clear cover, mm
(i)	Barrel wall thickness	
(a)	Upto and including 75 mm	8
(b)	Over 75 mm	15
(ii)	At spigot steps	5
(iii)	At end of longitudinal	5

Note : An effective means shall be provided for maintaining the reinforcement in position and for ensuring correct cover during manufacture of the unit. Spacers for this purpose shall be of rust proof material or of steel protected against corrosion.

Laying and Jointing Cement Concrete Pipes and Specials

17.2 Trenches:

The trenches shall be so dug that the pipes may be laid to the required alignment and at required depth.

Cover shall be measured from top of pipe to the surface of the ground.

The bed of the trench, if in soft or made up earth, shall be well watered and rammed before laying the pipes and the depressions, if any, shall be properly filled with earth and consolidated in 20 cm layers.

If the trench bottom is extremely hard or rocky or loose stony soil, the trench shall be excavated at least 150 mm below the trench grade. Rocks, stone or other hard substances from the bottom of the trench shall be removed and the trench brought back to the required grade by filling with selected fine earth or sand (or fine moorum if fine soil or sand is not available locally) and compacted so as to provide a smooth bedding for the pipe. Where excavation requires blasting operation, it shall be ensured that no pipes have been stacked in the vicinity and completed pipe line in the vicinity has already been covered before starting of blasting operations; this is necessary to prevent damage to the exposed pipes in the vicinity by falling stones as a result of blasting.

After the excavation of the trench is completed, hollows shall be cut at the required position to receive the socket of the pipes and these hollows shall be of sufficient depth to ensure that the barrels of the pipes shall rest throughout their entire length on the solid ground and that sufficient spaces left for jointing the underside of the pipe joint. These socket holes shall be refilled with sand after jointing the pipe.

Roots of trees within a distance of about 0.5 metre from the side of the pipeline shall be removed or killed.

The excavated materials shall not be placed within 1 metre or half of the depth of the trench, whichever is greater, from the edge of the trench. The materials excavated shall be separated and stacked so that in refilling they may be re-laid and compacted in the same order to the satisfaction of the Engineer-in-Charge.

The trench shall be kept free from water. Shoring and timbering shall be provided wherever required. Excavation below water table shall be done after dewatering the trenches.

Where the pipe line or drain crosses an existing road, the road crossing shall be excavated half at a time, the 2nd half being commenced after the pipes have been laid in the first half and the trench refilled. Necessary safety measures for traffic as directed shall be adopted. All types, water mains cables, etc. met within the course of excavation shall be carefully protected and supported. Care shall be taken not to disturb the electrical and communication cable met with during course of excavation, removal of which, if necessary, shall be arranged by the Engineer-in-Charge.

Where the pipes are to be bedded directly on soil, the bed shall be suitably rounded to fit the lower part of the pipe, the cost for this operation being included in the rate for laying the pipe itself.

Loading, transporting and unloading of concrete pipes shall be done with care. Handling shall be such as to avoid impact. Gradual unloading by inclined plane or by chain pulley block is recommended. All pipe sections and connections shall be inspected carefully before being laid. Broken or defective pipes or connections shall not be used. Pipes shall be lowered into the trenches carefully. Mechanical appliances may be used. Pipes shall be laid true to line and grade as specified. Laying of pipes shall proceed upgrade of a slope.

If the pipes have spigot and socket joints, the socket ends shall face upstream. In the case of pipes with joints to be made with loose collars, the collars shall be slipped on before the next pipe is laid. Adequate and proper expansion joints shall be provided where directed.

In case where foundation conditions are unusual such as in the proximity of trees or holes, under existing or proposed tracks manholes etc. the pipe shall be encased all-around in 15 cm thick cement concrete 1:5:10 (1 cement : 5 fine sand : 10 graded stone aggregate 40 mm nominal size) or compacted sand or gravel.

In cases where the natural foundation is inadequate the pipes shall be laid either in concrete cradle supported on proper foundations or on any other suitably designed structure. If a concrete cradle bedding is used the depth of concrete below the bottom of the pipe shall be at least 1/4th of the internal dia of the pipe subject to the min. of 10 cm and a maximum of 30 cm. The concrete shall extend up the sides of the pipe at least to a distance of 1/4th of the outside diameter of pipes 300 mm and over in dia. The pipe shall be laid in this concrete bedding before the concrete has set. Pipes laid in trenches in earth shall be bedded evenly and firmly and as far up the haunches of the pipe as to safely transmit the load expected from the backfill through the pipe to the bed. This shall be done either by excavating the bottom of the trench to fit the curve of the pipe or by compacting the earth under around the curve of the pipe to form an even bed. Necessary provision shall be made for joints wherever required.

When the pipe is laid in a trench in rock hard clay, shale or other hard material the space below the pipe shall be excavated and replaced with an equalizing bed of concrete, sand or compacted earth. In no place shall pipe be laid directly on such hard material.

When the pipes are laid completely above the ground the foundations shall be made even and sufficiently compacted to support the pipe line without any material settlement. Alternatively the pipe line shall be supported on rigid foundations at intervals. Suitable arrangements shall be made to retain the pipe line in the proper alignment, such as by shaping the top of the supports to fit the lower part of the pipe. The distance between the supports shall in no case exceed the length of the pipe. The pipe shall be supported as far as possible close to the joints. In no case shall the joints come in the centre of the span. Care shall be taken to see that super imposed loads greater than the total load equivalent to the weight of the pipe when running full shall not be permitted.

Suitably designed anchor blocks at change of direction and grades for pressure lines shall be provided where required.

17.3 Jointing:

Joints are generally of rigid type. Where specified flexible type joints may also be provided.

- (a.) Rigid Spigot and Socket Joint : The spigot of each pipe shall be slipped home well into the socket of the pipe previously laid and adjusted in the correct position. The opening of the joint shall be filled with stiff mixture of cement mortar in the proportion of 1:2 (1 cement: 2 fine sand) which shall be rammed with caulking tool. After a day's work any extraneous material shall be removed from the inside of the pipe and the newly made joint shall be cured.
- (b.) Rigid Collar Joint : The two adjoining pipes shall be butted against each other and adjusted in correct position. The collar shall then be slipped over the joint, covering equally both the pipes. The annular space shall be filled with stiff mixture of cement mortar 1:2 (1 cement: 2 fine sand) which shall be rammed with caulking fool. After a day's work any extraneous materials shall be removed from the inside of the pipe and the newly made joint shall be cured.
- (c.) Semi Flexible Spigot and Socket Joint : The joint is composed of specially shaped spigot and socket ends on the concrete pipes. A rubber ring shall be placed on the spigot which shall be forced into the

socket of the pipe previously laid. This compresses the rubber ring as it rolls into the annular space formed between the two surfaces of the spigot and the socket, stiff mixture of cement mortar 1:2 (1 cement: 2 fine sand) shall then be filled into the remaining annular space and rammed with a caulking tool. After day's work any extraneous materials shall be removed from the inside of the pipe and the newly made joint shall be cured.

(d.) Semi Flexible Collar Joint: This is made up of a loose collar which covers two specially shaped pipe ends. Each end shall be fitted with a rubber ring which when compressed between the spigot and the collar, seal the joint. Stiff mixture of cement mortar 1:2 (1 cement: 2 fine sand), shall then be filled into the remaining annular space and rammed with a caulking tool. After day's work, any extraneous material shall be removed from the inside of the pipe and the newly made joint shall be cured.

Great care shall be taken to ensure that the projecting ends are not damaged as no repairs can be readily affected from inside the pipe.

In all pressure pipe lines the recess at the end of the pipe line shall be filled with jute braiding dipped in hot bitumen or other suitable approved compound. Pipes shall be so jointed that the bitumen ring of one pipe shall set into the recess of the next pipe. The ring shall be thoroughly compressed by jacking or by any other suitable method.

The number of pipes that shall be jacked together at a time shall depend on the diameter of the pipes and the bearing capacity of the soil, for small pipes up to 25 cm diameter, six pipes can be jacked together at a time.

The quantity of jute and bitumen in the ring shall be just sufficient to fill the recess in the pipe when pressed hard by jacking or by any other suitable method. Before and during jacking care shall be taken to see that there is no offset at the joint.

17.4. Testing:

For pressure pipes, the completed pipeline shall be tested for pressure (Known as site test pressure) which shall not be less than the maximum pipeline operating pressure plus the calculated surge pressure, but in no case shall it exceed the hydrostatic test pressure.

17.5. Refilling of Trenches:

In case where pipes are not bedded on concrete special care shall be taken in refilling, trenches to prevent the displacement and subsequent settlement at the surface resulting in uneven street surfaces and dangers to foundations etc. The backfilling materials shall be packed by hand under and around the pipe and rammed with a shovel and light tamper. This method of filling will be continued up to the top of pipe. The refilling shall rise evenly on both sides of the pipe and continued up to 60 cm above the top of pipe so as not to disturb the pipe. No tamping shall be done within 15 cm of the top of pipe. The tamping shall become progressively heavier as the depth of the backfill increases.

17.6. MANHOLE COVERS & FRAMES

17.6.1. Manhole Covers

The covers and frames shall conform to IS 1726 for cast Iron and IS 12592 for pre-cast concrete covers and shall be of the following grades and types.

Table 3

Grades	Grade Designation	Type/shape of cover
Light Duty	LD - 2.5	Rectangular, Square, Circular
Medium Duty	MD - 10	Rectangular, Circular and Square (for pre-cast concrete manhole covers)
Heavy Duty	HD - 20	Circular-Square, Rectangular, (Scrapper Manhole)
Extra Heavy Duty	EHD - 35	Circular, Square, Rectangular, (Scrapper Manhole)

(A) Cast Iron Manhole Covers and Frames

Manhole covers and frame shall be manufactured from appropriate grade of grey cast iron not inferior than FG150 grade of IS 210. They shall be cleanly cast and shall be free from air and sand holes, cold shuts and warping. Covers shall have on its operative top a raised chequered design to provide for an adequate no-slip grip. The rise of chequers shall be not less than 4mm. Keyholes, keys and lifting devices shall be provided in the manhole covered to facilitate their placement in the frames and their operative maintenance. Manhole covers and frames shall be coated with materials having base with a black bituminous composition. The coating shall be smooth and tenacious. It shall not flow when exposed to temperature of 63°C and shall not be so brittle as to chip off at temperature of 0°C. Size and shape and performance requirement of manhole covers and frames shall conform to IS 1726.

Each manhole covers and frame shall have cast on them the following information:

Manufacturer's name or trade-mark

Grade designation

Date of manufacturer

The words SWD or 'Sewer' to denote 'storm water drain' or 'sewer' respectively

Identification marks as required by Engineer-in-Charge.

The cover shall be gas tight and watertight.

The sizes of covers specified shall be taken as the clear internal dimensions of the frame.

The approximate weight of the various type of manhole covers and frames shall be as per IS 1726.

The cover shall be capable of easy opening and closing and it shall be fitted in the frame in workmanship like manner.

(B) Pre-Cast Concrete Manhole Covers & Frames

Pre-cast reinforced cement concrete manhole covers intended for use in sewerage and water works shall generally conform to IS 12592.

(i) Materials

- (a.) Cement: Cement used for the manufacture of pre-cast concrete manhole covers shall be 43 grade Portland cement conforming to IS-8112.

- (b.) Aggregates: The aggregates used shall be clean and free from deleterious matter and shall conform to the requirements of IS -383. The aggregates shall be well graded and the nominal maximum size of coarse aggregate shall not exceed 20 mm.
- (c.) Concrete: The mix proportions of concrete shall be determined by the manufacturer and shall be such as will produce a dense concrete without voids, honey combing etc. The minimum cement content in the concrete shall be 410 kg/m³ with a maximum water cement ratio of 0.45. Concrete weaker than grade M-30 (design mix) shall not be used. Compaction of concrete shall be done by machine vibration.
- (d.) Reinforcement :The reinforcement steel shall conform to IS 1786. Reinforcement shall be clean and free from loose mill scale, loose rust, and mud, oil, grease or any other coating which may reduce or destroy the bond between the concrete and steel. A light film of rust may not be regarded as harmful but steel shall not be visibly pitted by rust.
- (e.) Fibers Steel: The diameter/equivalent diameter of steel fibers where used, shall not be greater than 0.75 mm. The aspect ratio shall be in the range of 50 to 80. The minimum volume of fibers shall be 0.5 percent of the volume of concrete. The reinforced concrete manhole cover and frame shall be designed in accordance with the provisions of IS 456. Clear cover to reinforcement shall not be less than 15 mm.
- (ii) Shapes and Dimensions: Shape, dimensions and tolerance of pre-cast concrete manhole covers and frames shall conform to IS 12592. Outside dimension of cover at top shall match with corresponding frame so that the maximum clearance at top between the frame and the cover all round the periphery is not more than 5 mm and the top surface of the frame and covers, is in level within a tolerance of +5 mm. For facility of removing the cover from the frame, suitable taper matching with taper given for the frame shall be provided to the periphery of the cover.
- (iii) Lifting Device: The minimum diameter of mild steel rod used as lifting device shall be 12 mm for light and medium duty covers and 16 mm for heavy and extra heavy duty covers. The lifting device shall be protected from corrosion by hot galvanizing or epoxy coating or any other suitable treatment.
- (iv) Finishing & Coating: To prevent any possible damage from corrosion of steel the underside of the covers shall be treated with anticorrosive paint. The top surface of the covers shall be given a chequered finish.

In order to protect the edges of the covers from possible damage at the time of lifting and handling it is necessary that the manhole covers shall be cast with a protective mild steel sheet of minimum 2.5 mm thickness around the periphery of the covers. Exposed surface of mild steel sheet shall be given suitable treatment with anticorrosive paint or coating. To prevent the top outer edge of frame from possible damages, it shall be protected by 25 mm X 3 mm mild steel flat as part of the frame.

(v) Physical Requirements

- (a.) General: All units shall be sound and free from cracks and other defects which interface with the proper placing of the unit or impair the strength or performance of the units. Minor chipping at the edge/surface resulting from the customary methods of handling during delivery shall not be deemed for rejecting.
- (b.) Load Test: The breaking load of individual units when tested in accordance with the method described in IS 12592 shall be not less than the values specified in Table 19.4.

Table 4

Grade of Cover	Type	Load in Tonnes	Diameter of Blocks in mm
EHD - 35	Circular, Square or Rectangular	35	300
HD - 20	Circular, Square or Rectangular	20	300
MD - 10	Circular or Rectangular	10	300
LD - 2.5	Rectangular, Square or Circular	2.5	300

- (c.) Fixing: The frames of manhole shall be firmly embedded to correct alignment and level in RCC slab or plain concrete as the case may be on the top of masonry, which shall be paid as extra unless specified otherwise.

17.7. MANHOLES

At every change of alignment, gradient or diameter of a drain, there shall be a manhole or inspection chamber. Bends and junctions in the drains shall be grouped together in manhole as far as possible. The maximum distance between manholes shall be 30m/60 m as required.

Manholes of different types and sizes as specified shall be constructed in the sewer line at such places and to such levels and dimensions as shown in the drawings or as directed by the Engineer -in-Charge. The size specified shall indicate the inside dimensions between brick faces of the manholes.

Where the diameter of the drain is increased, the crown of the pipe shall be fixed at the same level and necessary slope given in the invert of the manhole chamber. In exceptional cases and where unavoidable, the crown of the branch sewer may be fixed at lower level but in such cases the peak flow level of the two sewers shall be kept the same.

Sewers of unequal sectional area shall not be jointed at the same invert in a manhole. The invert of the smaller sewer at its junction with main shall be at least 2/3 the diameter of the main above the invert of the main. The branch sewers shall deliver sewage in the manhole in the direction of main flow and the junction must be made with care so that flow in main is not impeded.

No drain from house fittings, e.g. gully trap or soil pipe, etc. to manhole shall normally exceed a length of 6 m unless it is unavoidable.

Manholes 90 × 80 cm are generally constructed within compound for house drainage only and near the buildings for house drainage. Manholes 1.2 m × 90 cm are generally constructed for main drainage work for depths less than 1.5 m.

Manhole 1.4 m × 90 cm is of the arched type and is generally constructed for main drainage works where depth is 1.50 m or more. The width of manholes shall be increased more than 90 cm on bends or junctions or pipes with diameter greater than 450 mm and that the benching width on either side of the channel is minimum 20 cm.

Manholes 1.4 m internal diameter are generally constructed for main drainage works where depth is 2.45 m or more as an alternative to manholes of arch type. The diameter shall be increased suitably, for pipes with diameter greater than 450 mm in the same manner as in the case of rectangular manholes.

Before deciding size of manholes, Local Municipal Bye Laws shall be consulted. As a general guide some typical type designs of manholes followed in Delhi have been shown in Fig. 19.4 to 19.7. When manholes are constructed on foot path, these shall be provided with cover of medium duty casting and when built

within the width of the road under vehicular traffic, these shall be provided with cover of heavy duty casting.

17.8. Excavation

The excavation for manhole shall be true to dimensions and levels shown on the plans or as directed by the Engineer-in-Charge.

17.9. Bed Concrete

The manhole shall be built on a bed of cement concrete M-15 unless required by local authorities. The thickness of the bed concrete shall be 150 mm for manholes up to 4.25 m depth and 300 mm for depths beyond 4.25 m unless otherwise specified or directed by the Engineer-in-Charge. In bad ground, special foundations as suitable shall be provided.

17.10. Brick Work

The brick work shall be with class 75 bricks in cement mortar 1:4 (1 cement: 4 coarse sand). The external joints of the brick masonry shall be finished smooth, and the joints of the pipes with the masonry shall be made perfectly leak proof. For arched type and circular manholes, brick masonry in arches and arching over the pipes shall be in cement mortar 1:3 (1 cement: 3 fine sand). In the case of manholes of circular type the excess shaft shall be corbelled inwardly on three sides at the top to reduce its size to the cover frame to be fitted. The walls shall be built of one brick thickness for depths up to 4.25 m. Below a depth of 4.25 m in ordinary subsoil the wall thickness shall be increased to one and half brick and at 9.75 m below ground two brick thick walls shall be built.

17.11. Plaster and Pointing

The walls of the manholes shall be plastered inside with 12 mm thick cement plaster 1:3 (1 cement: 3 coarse sand) finished smooth. In the case of arched type manhole the walls of the manhole shall be plastered inside all-around only up to the crown level, and flush pointed for the shaft with cement mortar 1:2 (1 cement: 2 fine sand). Where the saturated soil is met with, also the external surface of the walls of the manhole shall be plastered with 12 mm thick cement plaster 1:3 (1 cement: 3 coarse sand) finished smooth up to 30 cm above the highest sub-soil water level with the approval of the Engineer-in-Charge. The plaster shall further be water proofed with addition of approved water proofing compound in a quantity as per manufacturer's specifications. In case Local Authorities/Bye Laws specify richer specifications, the same shall be adopted.

17.12. Foot Rests

Orange color safety foot rest of minimum 6 mm thick plastic encapsulated as per IS : 10910, on 12 mm dia steel bar conforming to IS: 1786, having minimum cross section as 23 mmx25 mm and over all minimum length 263 mm and width as 165 mm with minimum 112 mm space between protruded legs having 2 mm tread on top surface by ribbing or chequering besides necessary and adequate anchoring projections on tail length on 138 mm as per standard drawing and suitable to with stand the bend test and chemical resistance test as per specifications and having manufacture's permanent identification mark to be visible even after fixing, including fixing in manholes with 30x20x15 cm cement concrete block 1:3:6 (1 cement : 3 coarse sand : 6 graded stone aggregate 20 mm nominal size) complete as per design.

17.11. Manhole Covers and Frames

The frame of manhole shall be firmly embedded to correct alignment and levels in R.C.C. slab or plain concrete as the case may be on the top of the masonry. After completion of the work, manhole covers shall be sealed by means of thick grease.

A) S.W. GULLY TRAP:

Gully traps shall conform to IS 651. These shall be sound, free from visible defects such as fire cracks, or hair cracks. The glaze of the traps shall be free from crazing. They shall give a sharp clear tone when struck with light hammer. There shall be no broken blisters.

Each gully trap shall have one C.I. grating of square size corresponding to the dimensions of inlet of gully trap. It will also have a water tight C.I. cover with frame inside dimensions 300 x 300 mm the cover weighing not less than 4.50 Kg and the frame not less than 2.70 Kg. The grating, cover and frame shall be of sound and good casting and shall have truly square machined seating faces.

i) Fixing S.W. Gully Trap

- (a.) Excavation : The excavation for gully traps shall be done true to dimensions and levels as indicated on plans or as directed by the Engineer-in-Charge.
- (b.) Fixing : The gully traps shall be fixed on cement concrete foundation 65 cm square and not less than 10 cm thick. The mix for the concrete will be 1:5:10 (1 cement: 5 fine sand: 10 graded stone aggregate 40 mm nominal size). The jointing of gully outlet to the branch drain shall be done similar to jointing of S.W. pipes described above.
- (c.) Brick Masonry Chamber : After fixing and testing gully and branch drain, a brick masonry chamber 300 x 300 mm (inside) in brick work of specified class in cement mortar 1:4 (1 cement: 4 fine sand) shall be built with a half brick thick brick work round the gully trap from the top of the bed concrete up to ground level. The space between the chamber walls and the trap shall be filled in with cement concrete 1:5:10 (1 cement: 5 fine sand: 10 graded stone aggregate 40 mm nominal size). The upper portion of the chamber i.e. above the top level of the trap shall be plastered inside with cement mortar 1:3 (1 cement: 3 coarse sand), finished with a floating coat of neat cement. The corners and bottom of the chamber shall be rounded off so as to slope towards the grating.

C.I. cover with frame 300 × 300 mm (inside) shall then be fixed on the top of the brick masonry with cement concrete 1:2:4 (1 cement: 2 coarse sand: 4 graded stone aggregate 20 mm nominal size) and rendered smooth. The finished top of cover shall be left about 4 cm above the adjoining ground level so as to exclude the surface water from entering the gully trap.

For earthwork excavation, bed concrete brick work, plaster and pointing, R.C.C. work and refilling of earth, respective specifications shall be followed.

17.12. Cast Iron Pipes (CI Pipes)

The advantages of CI Pipes are good durability, good strength, low cost of maintenance and easy tapping facility for house connections by drilling and inserting a ferrule. The disadvantages are heavy weight, high transport cost and high laying and jointing cost.

17.12. 1. Types of CI Pipes

Based on the method of manufacture, CI Pipes are of two types –

- (i) Vertically cast or pit-cast pipes and

(ii) Centrifugally cast or spun pipes.

Vertically cast pipes are cast using vertical moulds as specified in IS 1537. Spun pipes are cast in accordance with IS 1536. Spun pipes are more compact, free from blow holes, of lesser weight and of smooth inner surface compared to centrifugally cast pipes. Standard lengths of CI spun pipes are 3.66m, 4.0m, 4.5m, 5.0m and 5.5m. Common sizes available are 80mm, 100mm, 125mm, 150mm, 200mm, 250mm, 300mm, 350mm, 400mm, 450mm, 500mm, 600mm, 700mm, 700mm, 750mm, 800mm, 900mm and 1000mm.

Longer sizes can be obtained against special manufacturing. Size referred to is the internal diameters. Based on the thickness of pipe shell, that provides capacity to withstand working pressure, CI pipes are classified as class LA, A, B, C, D and E. Class LA is taken as the base for evolving the series. Class A, B, C, D and E allows 10%,20%,30%,40% and 50% increase in thickness respectively. Class LA, A and B are commonly used whereas C, D and E are for special use.

17.12. 2. Pressure rating of CI pipes

The pressure and working pressure of class LA, A and B pipes are given in the tables below

TABLE 5 Test and working pressure of spigot and socket ended spun pipes

Class of pipe	Test Pressure at works kg/cm ²		Test Pressure at site Kg/cm ²		Minimum working pressure inclusive of surge pressure kg/cm ²	
	Upto 600mm	Above 600mm	Upto 600mm	Above 600mm	Upto 600mm	Above 600mm
LA	35	15	16	15	10	10
A	35	20	20	20	12.5	12.5
B	35	25	25	25	16	15

TABLE 6 Test and working pressure of Flanged spun pipes

Class of pipe	Test Pressure at works kg/cm ²		Test Pressure at site Kg/cm ²		Minimum working pressure inclusive of surge pressure kg/cm ²	
	Upto 300mm	350 to 600mm	Upto 300mm	350 to 600mm	Upto 300mm	350 to 600mm
B	25	16	25	20	16	16

17.12. 3. Cast Iron fittings

All cast iron fittings for all types of jointing, the fittings shall conform to IS: 1538. Only one type of fittings shall be used for all classes (LA, A, B etc.) of pipes.

Except otherwise required, all fittings shall be coated externally and internally. Each fitting shall be marked with trademark of manufacturer, nominal diameter, and weight, last two digits of the year of manufacture

and ISI certification mark.

17.12. 4. Ductile Iron Pipes (DI Pipes)

DI Pipes are centrifugally cast (spun) in accordance with IS 8329. DI Pipes are also called spheroidal graphite iron pipes or nodular pipes. Advantages of DI Pipes over cast iron pipes are greater tensile strength, significant elongation at break, high resistance against breakage due to impact and lighter in mass as compared to cast iron pipes. DI fittings shall conform to IS 9523. CI fittings in accordance with IS 13382 can also be used in DI pipe lines. DI pipes are available in standard lengths of 4m, 5m, 5.5m and 6m. Common sizes available are from 80mm to 2000mm. Size referred to is the internal diameter.

17.12. 5. Classification of DI Pipes

DI Pipes are classified as K7, K8, K9, K10 and K12 depending upon the service conditions and Manufacturing process. For screwed or welded flanged pipes, the minimum classes based on Working pressure criteria are as follows.

TABLE 6 Minimum class for DI flanged pipes

Nominal dia in mm	Screwed on flange minimum				Welded on flange minimum			
	PN - 10	PN - 16	PN - 25	PN - 40	PN - 10	PN - 16	PN - 25	PN - 40
80 – 450	K9	K9	K9	K9	K9	K9	K9	K9
500 – 600	K10	K10	K10	K10	K9	K9	K9	K10
700 – 1200	K10	K10	K10	----	K9	K9	K9	----
1400 - 2000	K10	K10	----	----	K9	K9	----	----

17.12. 6. Coating.

Pipes shall be protected internally and externally with coating.

i) External Coating: External coating shall be with metallic zinc rich paint not less than 130 grams per square metre with a local minimum of 110 grams per square metre or bitumen coating with mean thickness not less than 70 microns or polythene sleeving of density between 910 and 930 kg/cubic metre.

ii) Internal Lining: The following lining shall be provided Sulphate resisting cement mortar lining (IS. 12330 or IS. 6909) or High alumina cement mortar lining (IS. 6452)

17.12. 7. Method of Lining.

Cement mortar lining shall be done in the factory by centrifugal process to ensure uniform thickness.

17.12. 8. Marking

Each pipe shall be marked with the details of manufacturer, nominal diameter, class, last 2 digits of the year of manufacture and a short white line at the spigot end of pipe with push button joints.

17.12. 9. Ductile Iron Fittings

Ductile iron fittings shall conform to IS. 9523.

17.13. Unplasticised Polyvinyl Chloride (UPVC) Pipes :

PVC and Polyethylene pipes fall under the general title of Plastic pipes. uPVC pipes are manufactured in

accordance with IS:4985. The pipes are produced by extrusion process. The compound for extrusion comprises PVC resin, colouring pigments, opacifiers and heat stabilizers. Advantages of uPVC pipes are resistance to corrosion, light weight, toughness, rigidity, ease of fabrication, economical in laying, jointing and maintenance. Sizes available are 16mm, 20mm, 25mm, 32mm, 40mm, 50mm, 63mm, 75mm, 90mm, 110mm, 125mm, 140mm, 160mm, 180mm, 200mm, 225mm and 250mm. uPVC pipes are referred to the outer diameter.

17.13. 1. Classification of pipes

uPVC pipes are available in working pressure ranges of 2.5, 4, 6, 8 and 10 kg/cm² at 27°C and classified under the same working pressure.

17.14. High Density Polyethylene Pipes (HDPE pipes)

HDPE pipes shall conform to IS 4984. The pipes shall be manufactured by extrusion technique. HDPE pipes are classified on pressure ratings as Class 1 for 0.2 MPa, Class 2 for 0.25 MPa, Class 3 for 0.4 MPa, Class 4 for 0.6 MPa and Class 5 for 1 Mpa. The pipes shall be used for a temperature range up to 45oC. The recommended maximum working stress for the material at 27oC in a pipe is 50 kg/sq.cm. The pipes are referred to in terms of outer diameter.

HDPE pipes shall be flexible and tough, and at the same time resilient in order to conform to the topography of the land/trench when laid. They should be coilable. The diameter of the coil shall not be less than 25 times the outside nominal diameter of the pipe without any kinks. These pipes should be easily bent in installations reducing the specials like bend and elbow.

The pipes shall be marked with white paint on either side of the pipes. For coils, marking shall be made at both ends and at spacing not exceeding 5 metres in between.

Alternatively marking shall be done hot embossed on white base, every metre throughout the length of the pipe or coil. Marking shall contain the following information.

- a. Manufacturer’s name/ Trade name
- b. Designation of pipe (Grade of raw material, class of pipe, nominal outside diameter)
- c. Lot/batch number
- d. ISI certification mark and
- e. Raw material manufacturers

The color used for marking shall be as given below.

TABLE 7 Class of pipes and color of marking

Class of pipe	Class 1 – 2Kg/cm ²	Class 2 – 2.5 Kg/cm ²	Class 3 – 4.0 Kg/cm ²	Class 3 – 6.0 Kg/cm ²	Class 5 – 10 Kg/cm ²
Color	Orange	Red	Blue	Green	Yellow

A) Verification of Dimensions :

- (i) Method of measurement of diameter, thickness and ovality: Outside diameter shall be taken as the average of two measurements taken at right angles for pipes upto 110 mm dia. As an alternative, diameter shall be measured preferably by using a flexible Pi tape or circometer, having an accuracy of not less than 0.1mm.
- (ii) Thickness shall be measured by a dial vernier or ball ended micrometer. Resulting dimension shall be rounded to 0.1mm. Outside diameter shall be measured at a distance of at least 300 mm from the end of the pipe. In case of dispute, the dimension of pipes shall be measured after conditioning at room temperature for 4 hours.
- (iii) Ovality: It is the difference between maximum outside diameter and minimum outside diameter at the same cross section at 300mm away from the cut end. For coiled pipes, it shall be measured prior to coiling (or after re-rounding of pipes).

B) Performance requirements :

- (i) Visual appearance: Internal and external surfaces shall be smooth, clean and free from grooving and other defects. Ends shall be square with the axis of pipe. Slight shallow longitudinal grooves or irregularities in the wall thickness shall be permissible provided that the wall thickness remains within the permissible limits. The outside diameter, thickness, tolerance in thickness and ovality shall be as per relevant IS.
- (ii) Hydraulic characteristics: When subjected to internal pressure creep rupture test, the pipes shall not show signs of localised swelling, leakage or weeping and shall not burst during the test duration. The temperature, duration of test and induced stress for the test shall be as per details given in the table below:

TABLE 8 Type of Test, Temperature, Duration of Test and Induced Stress for Test

Sl. No	Test	Temperat ure 0C	Test Duration (Minimum holding time in Seconds)	Induce Stress (MPa)		
				PE 63	PE 90	PE 110
1	Type test	80	165	3.50	4.60	5.50
2	Acceptance Test	80	48	3.80	4.90	5.70

The internal test pressure for the above test shall be calculated by adopting the formula given below

$$P = 2 \times p \times s$$

(d---s)

where p=test pressure in MPa

s=minimum wall thickness in mm

d=outside diameter in mm

P=induced stress in MPa as given in the table above

- (iii) Reversion test: Longitudinal reversion shall not be greater than 3%
- (iv) Overall migration test: When tested from a composite sample of minimum of 3 pipes as per IS 9845, the overall migration of constituents shall be within the limits specified in IS 10146.
- (v) Density: Composite sample of minimum of 3 pipes as per IS 7328 shall have a density of 940.3-946.4 kg/ cu m at 27 deg C. The value of density shall not differ from the nominal value by more than 3 kg/cu.m as per clause 5.2.1.1 of IS 7328.
- (vi) Melt flow rate (MFR): Composite sample of minimum of 3 pipes as per IS 2530 at 190 deg C with nominal load of 5 kgf , MFR shall be 0.4 -1.1 g/ 10minutes and also shall not differ by more than 30% of the material used in manufacturing of pipes. The MFR of the material shall be 0.41-1.10g/10minutes when tested at 190deg C with nominal load of 5kgpf as determined by method prescribed in 7 of IS 2530. The MFR of the material shall be c within +20% of the value declared by the manufacturer
- (vii) Carbon black content and dispersion: For composite sample of minimum of 3 samples in accordance with IS 2530, the carbon black content shall be within 2.5+ 0.5% and the dispersion of carbon black shall be satisfactory.

C) Sampling, frequency of tests and criteria for conformity for acceptance tests:

- (i) Lot: It shall consist of same size, same pressure rating, same grade and manufactured essentially under similar conditions. The number of samples to be collected for various tests based on the size of lot shall be as per the table given below .The pipes shall be selected at random for sampling. Starting from any pipe in the lot, count them as 1,2,3,4 etc upto 'r 'and so on where 'r' is the integral part of N/n, N being the number of pipes in the lot and 'n' is the number of pipes in the sample. Every Rth pipe so counted shall be drawn as to constitute the required sample size.

TABLE 9 Sample Size, Acceptance Criteria

Number of pipes in lot	Sample number	Sample Size	Cumulative sample size	Acceptance number	Rejection number
1	2	3	4	5	6
Upto 150	First	13	13	0	2
	Second	13	26	1	2
	First	20	20	0	3

- (ii) Visual and dimensions: They shall be checked from the first sample size. Pipes failing to satisfy any of the requirements shall be considered as defective. The lot is satisfied if the number of defectives found in the first sample are less than or equal to the corresponding number given in column 6 of the table .The lot is defective if the number of defectives is greater than the number in rejection number. If the defectives number is between columns '5' and '6', the second sample of sizes shall be taken and examined .The lot is considered satisfactory, if the number of defectives found in the cumulative sample is less than or equal to the corresponding acceptance number. Otherwise it is considered not satisfactory.

- (iii) Hydraulic characteristics, reversion, overall migration, MFR and carbon black / dispersion tests: The lot having satisfied visual and dimensional requirements only shall be taken up for further testing. A separate sample size for each of the tests shall be taken as stipulated below and selected at random from the sample already examined for visual and dimensional inspection.

No of pipes	Sample size
Upto 150 pipes	3
151-1200 pipes	5

All the pipes in the sample shall be tested for requirements .The lot shall be considered satisfactory if none of the samples tested fails.

17.15. Transporting And Handling Pipes, Specials and Appurtenances.

17.15. 1. Transporting and handling:

Pipes and fittings must not be dropped, indented, crushed or impacted. Particular care should be taken to avoid scoring, scrapping and abrasion damage. Scores or scratches to a depth of 10% or more of wall thickness are sufficient to require rejection of the pipes and fittings. Pipes must not be stored or transported where they are exposed to heat sources likely to exceed 70° C e.g., vehicle exhaust gases.

17.15. 2. Safety Precautions:

- (A) PE particles can be abrasive if they enter eyes
- (B) Molten PE produced by welding operation will adhere strongly to the skin in the event of accidental contact. Should this occur, the affected part should be flooded with cold water. The molten or solidified material should not be removed from the skin and medical assistance should be obtained even for small burns.
- (C) Molten PE will yield a small quantity of fume especially at high temperatures. Work areas where welding is being carried out should be ventilated for safe working conditionD) In the event of fire, there are no restrictions on the type of extinguisher, which could be used.

17.15. 3. Handling and Storage of Pipes- General.

- (A) Pipes and fittings shall be handled and stored in accordance with the manufacturer's recommendations and subject to the approval of the Engineer. Handling operations shall be carried out with care.
- (B) During transportation, loading and unloading, pipes and fittings shall not be allowed to come into contact with any sharp projections, which may cause damage. During transit, pipes and fittings shall be well secured and adequately supported along their length. Pipes and fittings of plastic materials shall be covered during transportation.
- (C) Pipes and fittings shall be stored on a flat level area and raised above the ground on timber bearers so that the lowest point of any pipe or fitting is not less than 150 mm above the ground. Pipes and fittings supplied either on pallets or crated shall remain on the pallets or in their crates
- (D) Non-crated pipes shall be stacked to the approval of the Engineer. Spigot and socket pipes shall be stacked so that successive pipe layers have sockets protruding at opposite ends of the stack. Pipe of different sizes and thickness shall be stacked separately.
- (E) Each pipe and fitting shall be subjected to a visual inspection after off-loading at site and prior to installation.

(F) Pipes and fittings damaged during transportation, handling and storage shall be set aside and

(G) the damage brought to the attention of the Engineer. Proposals for repair shall be submitted in writing for the Engineer's approval. If in the Engineer's opinion the nature of any damage is such that the condition of a pipe has been impaired and cannot be repaired the pipe concerned shall not be incorporated in the Works.

17.15. 4. General Laying Jointing and Testing:

2.8.1 Setting Out: before any excavation for water pipeline/chambers is commenced, the Contractor shall define the centre line or other agreed reference line of the Works and erect the necessary profiles throughout their full length if so required by the Engineer. Pipes and fittings shall be examined for damage and carefully brushed out immediately before laying.

The formation of excavations for pipelines shall be dry, even and free of stones and other protrusions. Where exceptionally poor ground conditions are encountered at the trench formation the Contractor shall, at the direction of the Engineer, excavate down to firm ground or 300mm below formation, whichever is the less. The extra excavation shall be backfilled with either concrete or selected granular material as directed by the Engineer.

Where pipelines are to be laid in trench, the Contractor shall provide, fix and maintain at such points as may be directed by the Engineer properly painted sight rails and boning rods of predetermined measurement for the boning in of individual pipes to correct alignment. The sight rails shall be at a suitable height vertically above the line of pipes or immediately adjacent thereto and there shall at no time be less than three sight rails in position on each length of pipeline under construction to any one gradient.

Pipelines shall be temporarily capped when pipe laying ceases, to prevent the ingress of foreign matter. The Contractor shall ensure that the pipes remain clean and free from dirt and deposits and if required by the Engineer the pipelines shall be cleaned out using approved methods and equipment, which do not damage to the internal lining of the pipes and valve chambers.

Colour coded plastic marker tapes shall be placed over the pipeline even when not separately Specified.

Where pipelines are to be constructed in any tunnel heading or duct provided by the Contractor, the minimum clearance between the inside face of the tunnel heading or duct and the pipe shall be 200 mm unless otherwise shown on the Drawings.

The Contractor shall adopt a suitable method of controlling the alignment of a pipeline installed in a tunnel heading or duct to the approval of the Engineer.

Regime of testing: The following regime of testing shall be followed throughout the period of Contract.

Tests at the start of the Contract.

In house tests shall be conducted as per relevant IS code and the test results submitted together with the request for material approval.

Tests during the Contract Period

Type tests and acceptance tests as stipulated in relevant IS shall be strictly carried out at the factory and acceptability of pipes ascertained before despatch to site. In addition, field hydrostatic test shall be done and quality of pipes ensured.

17.15. 5. Sluice Valves

Sluice valves shall comply with IS 14846 and be flanged unless otherwise stated and be tested to the requirements of Class 1. Maximum Differential Pressure and Maximum Working Pressure shall be as per relevant IS standards.

Sluice valves shall be of the double-flanged ductile iron wedge-gate type and shall have non-rising spindles unless otherwise specified or shown on the Drawings. They shall have a cast iron body with renewable gunmetal faces on body and wedge and bolt-on cast iron bonnet. Rising stem valves shall also incorporate a combined yoke.

Where sluice valves above 350 mm bore are mounted with the spindle in the horizontal place the valve body shall be fitted with renewable gunmetal machined gate slides and the gates with renewable hard bronze shoes accurately machined to reduce sliding friction.

A sluice valve above 500 mm bore (300 mm if power actuated) shall be provided with jacking screws and valves above 350 mm bore where mounted in a horizontal pipeline shall be provided with feet.

Unless otherwise specified each valve shall be provided with a suitable hand wheel of adequate diameter for the duty required and gearing shall be supplied where necessary to ensure that the required operating force applied by hand to the rim of the wheel does not exceed 25Kgf.

Hand wheels shall have smooth rims and the direction of closing which shall be clockwise shall be cast on them. Vandal and weatherproof clear polycarbonate tube covers shall be securely fitted to protect the threads of rising stems and spindles and tubes shall be clearly and permanently engraved to indicate the position of the valve.

Valve stems shall be of forged aluminium bronze or stainless steel machined all over and with a machine cut robust trapezoidal or square form thread operating in a gunmetal nut.

Stem seals shall be of the stuffing box and gland form arranged for easy replacement of packing and shall be accessible for maintenance without removal of the valve from service.

Extension spindles headstocks and foot brackets shall be provided where specified. Where possible providing the valve is not subject to submergence. The extension spindle shall be of the non-rising type and a cast iron bridle piece or similar shall be incorporated on valves of the rising spindle type for this purpose.

Where rising stem valves are subject to submergence the extension spindle shall also be of the rising type with the threaded portion positioned above top water level. Extended spindle installations shall include all necessary brackets intermediate supports etc.

Headstocks for non-rising spindle installations shall incorporate a valve position indicator. Extension spindles shall be of stainless steel or manganese steel and shall conform with the requirements of valve stems with the exception of non-threaded sections which may be of mild steel. Extension spindle couplings shall be of the muff type and shall be drilled and provided with a nut and bolt for securing the spindle to the valve stem, which shall likewise be drilled to accept the bolt.

Extended spindle installations of the rising type shall be provided with thrust tubes between

valve and headstock in order to absorb the thrust in both directions of operation for valves of 300 mm bore and above and for all motorised/actuator operated valves. Thrust tubes shall incorporate all necessary fixing brackets and spindle guide plates.

Where valves are required to be operated by the keys spindle caps shall be fitted.

The caps shall be drilled and each provided with nut and bolt for securing to the spindle which shall likewise be drilled to accept the bolt. Where caps are fitted they shall be supplied complete with operating key.

All hand wheels, headstocks, foot brackets, guide brackets and thrust tubes shall be of cast iron. Fixing nuts and bolts supplied by the manufacturer shall be galvanized iron of appropriate clauses of relevant IS.

Valves shall carry identification marks and/or plates in accordance with the Indian Standard and those for use on process plant shall carry additional brass plate carrying valve identification and a brief description of its function.

Valves shall be sized such that the velocity through the valve when fully open does not exceed 2.25 metres per second at the rated flow. They shall have flanges to IS. 1538 and shall be capable of withstanding the same test pressures as the pipeline on which they operate. All nuts and studs subject to vibration shall be fitted with spring washers or locking tabs.

All valves shall be coated with solvent free coal tar epoxy resistant to mineral acid, which has pH

≤

2. All materials used in the manufacture of the valves shall conform to the following minimum

Standards: -		
Cast Iron*	BS 1452 Grade 220	
Gunmetal	BS 1400 Grade LG2	
Aluminium Bronze	BS 2872 Grade Ca104	
Stainless Steel	BS 970: Part 1	Grade 316531
Manganese Steel	BS 970: Part 1	Grade 150 M19

*Spheroidal Graphite Iron to ISO 1083 may be used as an alternative to Cast Iron for waterworks standard valves to BS 5163.

17.16. AIR VALVE

The valve shall be capable of exhausting air from pipework automatically when being filled, the air being released at a sufficiently high rate to prevent the restriction of the inflow rate. Similarly the valve shall be capable of ventilating pipework automatically when being emptied, the air inflow rate being sufficiently high to prevent the development of a vacuum in the pipelines. The valve shall also automatically release air accumulating in pipework during normal working conditions.

Air valves shall thus be designed to automatically operate so that they will;

- a. Positively open under internal pressure less than atmospheric pressure to admit air in bulk during
- b. Pipeline draining operation.
- c. exhaust air in bulk and positively close as water, under low head, fills the body of the valve during filling operation
- d. not blow shut under high velocity air discharge; and
- e. Exhaust accumulated air under pressure while the pipe is flowing full of water.

All air valves shall be constructed so that internal working parts which may become necessary for repairs shall be readily accessible, removable, and replaceable without use of special tools and removing the valve from the line

Air valves shall be Kinetic double orifice type as per IS 14845 and tamper proof unless otherwise directed by the Employers Engineer. A buoyant rigid float shall seal the large orifice and the chamber housing shall be designed to avoid premature closing of the valve by the air whilst being discharged. Small orifice shall discharge small air volume during operation under full internal pressures. All air valves shall be provided with isolating sluice valve and flanged end connection

The aperture of valves must be properly designed for which the Contractor shall submit design calculations for necessary approvals before the procurement of valves.

All branched outlets including air valve tees will be provided with one ½” BSP coupling duly plugged for measurement of pressure in due course. The closing plug shall be in Stainless Steel (AISI 304 or equivalent) with Hex. Head and shall be provided with copper washer for sealing

Material of construction of air valve shall comply with following requirement

Body and cover	Grade GGG 40
Float	Polycarbonate up to 50 NB / SS 304-above 50 NB
Internal Linkages	Stainless Steel 304
Gasket, seal ring, sealing face	EPDM
Vent valve	Brass
Coating	Electro-statically applied epoxy resin- Internally and externally (min 250 micron)

Non-Return Valve/ Rubber Flap Check Valve

- i). The valve shall be suitable for mounting on a horizontal pipeline and flow direction shall be clearly embossed on the valve body.
- ii). Valves shall possess high speed closing characteristics and be designed for minimum slam condition when closing.
- iii). Dual plate check valves shall conform to API 594 and API 598. They shall have metal to metal sealing. The spring action shall optimize the equal closing rates of each plate especially when the friction coefficients are uneven due to one plate resting upon one another. The plates shall not drag on the seat while opening. The plates shall not vibrate under full or partial flow condition. Valves shall possess high speed closing characteristics and be designed for minimum slam condition when closing.
- iv). The minimum body-wall thickness shall conform to those given in Table 1B of API Standard 594
- v). The face-to-face dimensions of valves (including valves with ring-joint facings) shall conform to those mentioned in Table 2B of API Standard 594
- vi). The valve body shall be furnished with a clearly visible forged, machined-in, or die-stamped arrow to indicate the direction of flow through the valve.
- vii). Maximum permissible seat leakage is 7cc/Hr/cm nominal diameter of valve.
- viii). Material of construction of valves shall comply with following requirements

Pressure rating	PN 16
Body	ASTM, A 395
Plate	ASTM, A 351 Gr CF8M
Hinge Pin /Stop Pin/wetted parts	SS AISI 316
Springs	SS. ASTM A 313
Seat	SS AISI 316
Retainer	SS-304

GATE VALVE/SLUICE VALVE

Sluice valve shall generally conform to IS 14846 and shall be resilient seated type. They shall be of non-rising spindle type except for the valves for bypass. The gate face rings shall be securely pegged over the full circumference. Valve of 400 mm and above shall be furnished with a bushing arrangement for replacement of packing without leakage. They shall also have renewable channel and shoe linings. The gap between the shoe and channel shall be limited to 1.5 mm. Valve of 200 mm and above shall be provided with thrust bearing arrangement for ease of operation.

Valve of diameter 400 mm and above shall be provided with enclosed gear arrangement for ease of operation. The operation gear of all valves shall be such that they can be opened and closed by one man against an unbalanced head 15% in excess of the maximum specified rating. Valve and any gearing shall be such as to permit manual operation in a reasonable time and not exceed a required rim pull of 200 N.

Valves spindles and hand wheels shall be positioned to give good access for operational personnel. Hand wheels shall be arranged to turn in a clockwise direction to close the valve, the direction of rotation for opening and closing being indicated on the hand wheels

Valves shall have two position marked at the shut end of the scale, first one corresponding to the position of the gate tangential to the bore of the seating and the second position below the first, corresponding to the position of the gate as it sits on the seating after moving a further distance equal to the depth of the seating.

All valves on pump suction and delivery piping shall be with electrical actuators. All Sluice valves shall be open end tested.

The body and bonnet shall be of ductile cast iron of grade GGG-40, wedge with fully encapsulated EPDM rubber W-270 (approved for drinking water) and seals of NBR. The valves should be with replaceable stem nut and replaceable sliding shoes. Valve stems shall be of single piece thread rolled. Valve shall have 3 “O” rings of NBR for stem sealing. Gate valve shall be compatible for buried applications without valve chamber. Face-to-face dimensions as per BS 5163-89/IS 14846-PD/EN 558F4 and flange connections as per IS 1538, Maximum Valve operating torque should be at least 40% less than the torque as stated in the standard EN 1074. Electrostatic epoxy powder/liquid coating (EP-P) inside and outside colour blue RAL 5005 with minimum coating thickness of 250 microns. The EPDM rubber & Epoxy Powder should be approved by W 270.

Material of construction

Body, Bonnet	Ductile Iron GGG 40 (EN-JS- 1030) / Spheroidal Graphite Iron IS: 1865 Gr 400/12
Wedge (fully rubber encapsulated)	Ductile Iron GGG 40 (EN-JS- 1030) / Spheroidal Graphite Iron IS: 1865 Gr 400/12 encapsulated with EPDM rubber - W270 approved grade.
Spindle/Stem	SS: IS: 6603 12Cr13/22Cr 13; AISI 410/AISI 420
Stem Nut	Brass

Bonnet Gasket	EPDM rubber - W270 approved grade
Internal Fasteners	Stainless Steel SS316/304
Stem Sealing	Toroidal NBR sealing rings (Min 03 'O' Rings)
Coating	Inside & Outside epoxy powder coated; DFT minimum 250 micron, shade RAL 5005 (BLUE)

LIST OF APPROVED MANUFACTURERS/MAKES:-

All material should be ISI mark / ISO 9000 accredited company or manufactured by Public sector/Govt. owned Companies or of the firms of repute. However Govt. / Public Sector makes are preferred makes. It is necessary to mention make of equipment Bidder intends to use. If Bidder does not mention make, the owner would be free to mention the make of his choice.

Sr. No.	MATERIAL	MAKE
1	Cement:	ACC/Ultra tech/Century/Lafarge/Ambuja/Emami
2	Paints/Textured Paints:	Asian/Jenson Nicholson/Nerolac/Berger/ICI
3	GI Pipes:	Jindal/TATA/Zenith
4	UPVC Pipes and Fitting:	Finolex/Supreme/Kisan
5	Toilets SS Wash basins:	Nirali/Jayna/Neel kanth/Deepali
6	HDPE DWC Pipes:	Alom Poly Extrusions/Tuffline Technoplast/Tirupati
7	D.I.K-9Pipe&Fittngs	Lanco/Jindal/Kejriwal
8	C.ID/F Sluice Valve	Hawwa/IVC/Gavane Patil/Upadhyay
9	MCCB	ABB (T-MAX) / Siemens (3VT) / Legrand
10	Connectors	Elmex / Raychem
11	MCB (7 kA breaking capacity)	Siemens (5SL) / Legrand (Lexic) / ABB
12	FRLS LT Wires	Polycab / Havells / KEI
13	Timers	Siemens / Havells / Legrand
14		
15	Switches & accessories	Legrand / Havells / HPL
16	PVC Conduit	Precision / BEC / AKG
17	Motor Starters / Contactors	ABB / Siemens / L&T / Alstom
18	LED Light Fittings & Lamps	Wipro/Philps/Syska/Local Manufactures of Haryana But ISO certified only
19	AL. AR. LT XLPE FRLS Cable	Havells / Polycab
20	Distribution Boxes & accessories	Siemens / Legrand / Hagger
21	Air Circuit Braker	ABB (EMAX) / Siemens (3VT) / Alstom
22	Panel Meter	Automatic Electric Ltd / Secure /
23	HRC Fuse & base	Siemens / C&S / ABB
24	Cable Accessories:	
25	Gland	Raychem / 3M / Dowells
26	Lugs	Dowells / RayChem
27	Selector Switch	Automatic Electric Ltd
28	Chemical Earthing	AS per ISO, CPRI, EFSCL, ERTL approved certification.
29	RMU with FPI	As per DHBVN Board approved vendor list & ISO, CPRI, EFSCL, ERTL approved certification.
30	Load Break Switch	Alstom / Siemens / ABB & As per CSPDCL approved vendor list & ISO, CPRI, EFSCL, ERTL approved certification.
31	HT AL. AR. XLPE UE 11/11 FRLS CABLE	Havells / Polycab
32	Cable tag	As per , DHBVN approved vendor list
33	LT Feeder Pillar Box	Siemens (Seapen) / ABB / Legrand (OEM)
34	Structural/Reinforcement Steel:	SAIL/TATA/VSP/Steel producers having license from BIS

LIST OF APPROVED MAKE / MODEL

b) Civil,

S. No.	Description	Approved Makes
1	Cement (Grey)	ACC/L&T/J.K / BIRLA / Vasvdatta, Ambuja and other ISI marked make
2	T.M.T. Steel	SAIL/TATA/RINL/IISCO/ Vizag
3	Structural steel	SAIL/TATA/JRINL/IISCO/ Vizag
4	Ready Mixed Concrete	ACC/L&T /Ultratech/ Lafarge /RMC / Godrej
5	Precast Concrete	Siporex Ind.; B.G. Shirke & Co.; Supreme
6	Products	Concrete Minato Blocks-
7	Antitermite Treatment	Chemical and agency - Approved by IPCA.
8	Stainless Steel	Jindal/SAIL/Golden
9	Ceramic Tiles	Nitco /Kajaria /Euro
10	Vitrified Tiles	R.A.K./ Kajaria/Euro
11	Terrazzo & Cement	NITCO; Automatic Tiles; NIMCO; GICO Tiles,
12	Tiles	Kolkata; National Tiles, Delhi; Alankar Tiles Pvt. Ltd., Indore; Super Tiles; Shirwadkar Tiles; Kirti Tiles, Pune
13	Kotah Stone	As approved by Architect
14	Telephone Black Granite	As approved by Architect
15	ABD Paint	Asian Paints / Nerolac / ICI
16	Texture Paint - External	Nitco
17	Enamel Paint	Asian Paints / ICI
18	Aluminium Sections For Doors, Windows & Wall	Jindal; Hindalco; Geeta; Bengal Rolling
19	Spans	Shutters-Kolkata
20	Anodized aluminium fittings for doors/windows	Crown/ALANS/Classic/Bharat/ Argent
21	Laminate	Formica/Greenlam/Merinolam
22	Flush Doors	Duraboard /Kit ply / Merino Ply / Shreeji Doors, Anand Wood Craft and other ISI marked make
23	Steel Doors,	Sen Harvic; AGEW; Hopes Metal; Multiwyn; R.L.
24	Windows & Pressed	Vala & Sons; Modern
25	PVC / FRP Doors & Frames	Deep Doors; Fibroplast-Latur
26	Frames	
27	Polycarbonate Sheet	Danpalon / Alcox / Polygal / Sabic and other ISI marked make
28	Mild Steel Butt Hinges/Piano Hinges	Jolly/Garg/AMIT/ASI Supreme
29	Water Proof cement paint	Snowcem/Asian Paints/Berger
30	Nuts Bolts /Screws	Kundan/Puja/Atul
31	Mineral Fiber Ceiling	Lloyd/Nittobo/ Armstrong
32	Welding Rods	ADOR/ Cosmos/ Esab/ Super Bond (S)
33	Fastner	Fisher/ Hilti
34	A.C. Sheet :	Asbestos Cement Ltd. (Everest); Charminar.
35	Expansion Joint &	Shalitek; Tiki Tar Industries; STP Ltd. (Shalimar
36	Tarfelt Waterproofing	Tar Products); Lloyd Insulation (I).
37	Integral Water	Accoproof; Cico; Impermo; Pidilite; Roff.; Mc
38	Proofing Compound	Bouchmie; Fosroc.

18. TECHNICAL SPECIFICATION OF LANDSCAPE WORK

18.1 Sign Board (Project information)

The Contractor shall provide few sign boards at the site of works of approved size and designs, which provides.

The name of the project

The name and address of the Employer, the contractor and the consultant

The name and short description about the projects

The amount of contract price

Starting and completion dates

Such signboards shall be located at places in the project coverage area as directed by the Engineer. Contractor shall take care of signboards and replace it in case of loss, damage, theft etc. The signboard may be in English / Hindi or both as directed by the Engineer.

18.2 Sampling and Testing during construction

The Contractor shall be responsible to develop a quality control program as per IS Codes and to provide all necessary materials, apparatus, instruments, equipment, facilities and qualified staff for sampling, testing and quality control of the materials and the works under the Contractor. Without limiting the generality of the foregoing, the Contractor shall either (i) establish a testing laboratory at the site of Works which is adequately equipped and staffed to carry out all sampling and testing in accordance with the requirement and provide all field equipment and apparatus as necessary to conduct all specified in-situ tests and/or any Tests on Completion, or (ii) arrange for routine sampling, testing and reporting, as required, through a certified independent testing laboratory acceptable to the Employer.

All costs of such sampling, testing and reporting of test results will be borne by the Contractor, and the Contractor shall include sufficient provisions in his tendered rates to allow for sampling and laboratory testing under the direction of the Engineer In- Charge (E in C).

18.3 Order of Precedence, Clarifications and Interpretation

When the various specifications and codes referred to in preceding portion are at variance with these specifications and with each other, the order of precedence will be Bill of Quantities (BOQ), Technical specifications and Drawings.

The attention of the bidder is drawn to those clauses of these specifications and of BIS codes, which may require either clarification by Engineer, or the mutual agreement of employer and contractor. In such cases it is the responsibility of the contractor to seek clarification on any uncertainty and obtain prior approval of the Engineer during pre bid meeting before taking up the supply/construction.

18.4 Submittals

18.4.1 Materials, product data and equipment schedule

All specifications, diagrams, samples, drawings and such other data shall be provided by the Contractor, in a format to be agreed with the Employer, which may be required to demonstrate compliance with the specification. This shall include but not limited to the following information:

Originals of catalogues and engineering data sheets for manufactured items; each item and option to be provided shall be clearly marked and each item not to be provided shall be deleted.

Literature to show that products provided meet the requirements for material, construction, operation and testing.

Information on the following items as a minimum:

Pipes; pipe jointing systems, manhole covers and frames, chamber covers and frames etc

Manufacturer's installation instructions for all items.

Certified reports for all tests and inspections designated herein, signed and sealed, showing full compliance with referenced standards.

Maintenance requirement and procedures.

Period of guarantee for the products.

Operation manual

18.2.2 Approval of material

Approval of all sources of material for works shall be obtained in writing from the E in C before their use on the project.

The Contractor at no extra cost will submit raw and processed samples of all materials.

18.2.3 Completion Drawings / As Built Drawing

On completion of work, Contractor shall submit one complete set of original tracings developed in Auto CAD, soft copy in CD in PDF as well as editable form and two prints of "Completion/As Built" drawings to the E in C. These Drawings shall be accurate and correct in all respects and shall be shown to and approved by the E in C. These drawings shall have but not limited to the following information:

(A) Civil works

- (i) Plan showing services crossing i.e pipes, cables below paved areas.
- (ii) Plan showing final location, demarcation of wall benches, street furniture such as benches, lights, bins etc.
- (iii) Plan showing location of water feature structure and underground sump for fountain pump with capacity and filtration system specifications and underground tank

(B) Landscape lighting

- (i) Plan showing circuit diagram, light fixtures, operational specifications, crossings, switch box, tap points for electrification along with technical specifications of the Road & the open spaces.
- (ii) Plan showing all electrical works .

(C) Landscape drainage

- (i) L-section showing the G.L, I.L, slope, top of drain, connecting level of the branch lines etc

(D) Landscape horticultural works

- (i) Plan indicating final placement of plant material such as trees, palms, shrubs, climbers and ground covers as per site development.
- (ii) Maintenance schedule to be adopted for the upkeep of the green spaces. Listing out the periodic use of insecticides, pesticides, and manure.
- (iii) Detail of manpower class wise, tools and tickles, machinery made available at the site during of maintenance of horticultural works.

Contractor shall provide four sets of catalogues, performance data and list of spare parts together with the name and address of the manufacturers for all electrical and mechanical equipment provided by him and installed in the Project.

All “Warranty cards” given by the manufacturers shall be handed over to the Engineer-In-Charge.

Completion certificate shall not be issued unless the as-built drawings are submitted as indicated above.

18.5 Materials

- a. All materials used in the works shall conform strictly to the Tender specifications.
- b. All materials, as specified shall be used with the approval of the Engineer – In- Charge.
- c. Unless otherwise specified and expressly approved in writing by the FSCL Engineer- In- Charge (E in C).

18.5.1 Quality control on works and material

- (i) The contractor shall be responsible for the quality of the works in the entire construction works within contract. The contractor shall, therefore, have own independent and adequate set up for ensuring same.
- (ii) The Engineer in charge shall inspect the work from time to time during and after construction and ascertain the quality of the work tested (by contractor Testing and Quality Control Units or by any other agency deemed fit by him and approved by the E in C generally as per the requirements of BIS standards. Additional tests may also be conducted where, in the opinion of the E in C, need for such test exists.
- (iii) The contractor shall provide necessary cooperation and assistance in obtaining the samples for tests and carrying out the field tests as required by the Engineer from time to time. This may include provision of labour, attendance, assistance in packing and dispatching and any other assistance considered necessary in connection with the tests.
- (iv) Similar permission from the Engineer in charge shall be obtained in respect of other items of work prior to proceeding with the next stage of construction. The Contractor shall offer the Engineer any sequential work Ready for Inspection (RFI) after the said work has been certified by his E in C as ready to proceed with.
- (v) The contractor shall carry out modification in procedure of work, if any, as directed by the Engineer in charge during inspection.
- (vi) For testing of samples of soil, soil mix, aggregates, manhole & pit covers / gratings etc. samples as required by standards shall be furnished by the Contractor. All the test as required or instructed by E in C shall be carried out by contractor at their own cost.
- (vii) For cement, reinforcing steel and similar other materials where essential tests are to be carried out at the manufacturer’s plants or at laboratories the cost of samples, sampling, testing and furnishing of test certificates shall be borne by the Contractor. He shall also furnish the test certificates to the E in C. All materials shall be tested to relevant BIS codes.

- (viii) Where the Engineer considers that in the interest of the control of the quality on materials or workmanship, modifications, if any, are necessary, the contractor shall carry out such modifications.

18 Section: 2 Technical Specifications

19.1 General Requirements

- I. The contractor shall be verification of ground reality prior to execution of work. The contractor shall carry out topographical survey of the proposed work to establish final alignment of structures. Reference bench mark will be shown at site and level value of the same will be provided to the contractor by the E in C for carrying out topographical survey.
- II. The contractor shall furnish updated map and level information near the site to the E in C as a verification of data given in the drawings by the E in C. Any variation found in the details provided in the drawings provided by the Engineer shall be corrected by the Engineer. The revised drawings shall be used for implementation of construction.
- III. All landscape works including civil, drainage, lighting and irrigation, pipes and fittings and appurtenance shall be laid at proper depths or to the required slopes in a neat workman like manner.

19.2 Alignment and Grade

All landscape works, civil, lighting and drainage system shall be laid to alignment and gradient shown on the drawings but subject to such modifications as shall be ordered by the E in C from time to time to meet the requirements of the works at site. No deviations from the lines, depths of cutting or gradients as shown on the plans and sections shall be permitted except by the express direction in writing of the Engineer-In-Charge.

19.3 Excavation and Backfilling

19.3.1 General

The earthwork excavation in trenches and structures shall be carried out as shown in the drawings and as per specifications.

All applicable Indian Standard, unless otherwise specified herein, shall be applicable. In all cases, the latest revision of the codes shall be referred. IS 3764(1992): Code of safety for excavation work, IS 1200: Part 1(1992): Methods of measurement of building and civil engineering works: Part 1 Earthwork, IS: 2720(Part 2, 7, 8, 28&29): For method of test for compaction.

The Contractor shall be responsible for the adequate pumping, drainage and bailing out of water from the excavation. In case of failure to make such provisions or any other provisions, which may result in unsuitable sub-grade conditions, the Contractor shall replace and repair the sub-grade to the satisfaction of the E in C, at his own cost and responsibility.

During construction all excavated good earth shall be stacked and maintained free from debris.

Contractor should assess the availability of extra earth required for refilling in case of shortage in any particular reach well before quoting rates. Even in case the Contractor resorts to mechanical excavation, the Contractor should take care of proper refilling, consolidation and disposal of surplus earth.

19.3.2 Shoring and bracing (timbering)

The Contractor shall supply, fix and maintain necessary sheathing, shoring and bracing etc., in steel or wood, as may be required to support the sides of the excavation, to protect workmen in the trench and to prevent any trench movement which might any way injure or delay the work, change the

required width of the trench, make unsafe condition for adjacent pavements, utilities, buildings or other structures above or below ground.

Sheathing, shoring and bracing shall be withdrawn and removed as the backfilling is being done, except when the Engineer may agree that such sheathing, shoring and bracing be left in place, at the Contractor's request. In any case, the Contractor shall cut off any such sheathing at least 600 mm below the surface and shall remove the cut off material from the trench.

All sheathing, shoring and bracing which are left in place under the foregoing provisions shall be removed in a manner so as to not endanger the completed work or other structures, utilities or property, whether public or private.

Timbering shall be provided as per safety code for excavation works IS: 3764 (Clause5).

Timber shoring shall be close or open, depending upon the nature of soil and depth of pit or trench. The type of timbering shall be as approved by the Engineer.

19.3.3 Back filling of trenches

a) General

The Contractor shall use selected surplus soils from excavated materials for backfilling and all fill material shall be subject to the E in C's approval. The excavated materials suitable for backfilling shall be stored not closer than 600 mm from the edge of the trench and shall not obstruct any public utilities or interfere with travel by local inhabitants or general public. Handling and storage of excavated materials must meet with the regulations of the Local Government Authorities. The detailed specifications for backfilling shall be IS: 3114-1994.

b) Method of Backfilling

1. Excavated Trench, Manhole and Roadside chamber shall be backfilled to original ground level or to such other levels, as the E in C may direct. All backfilling shall be carried out in orderly manner expeditiously and consistent with good workmanship.
2. Backfill material put into the trenches for backfilling, shall unless otherwise specified be compacted and built up as to minimise future settlement as much as is reasonably possible. For this, care shall be exercised in selecting backfill material free from large hard clay lumps, especially in cramped areas directly adjoining the walls of structures.
3. Backfilling in trenches shall be done as pipe laying progresses, with the permission of the Engineer, after the pipe or conduit is properly bedded, jointed and inspected and the Engineer properly records all measurements for the location of junctions. However the trench shall be backfilled after successful completion of testing. Backfilling around and over the pipe, conduit, or structure shall be taken up uniformly on all sides and in the sequence and manner specified hereinafter, with care to avoid the displacement or damage to the pipe, conduit or structure. Trenches should be carefully guarded till back filling.
4. For the purpose of backfilling, the depth of trench shall be divided into the following three zones measured from bottom to top of trench, as follows:
5. Zone A: From bottom of trench to the centre line of pipe,
6. Zone B: From the level of centre line of pipe to a level of 300 mm above the top of pipe,
7. Zone C: From a level of 300 mm above the top of pipe to the top of trench.

8. Backfilling in the trenches and around structures shall be carried out in horizontal layers of uniform thickness of not more than 150 mm when measured loose. As may be necessary to attain maximum compaction, the backfill material shall be moistened by sprinkling with water. After placing each layer of backfill material, the layer shall be thoroughly and uniformly compacted by means of mechanical plate vibrators or hand tampers.
9. After the backfill material is placed in Zone A and Zone B as specified above, the remaining portion i.e., Zone C of the trench may be machine backfilled. Even in this case the backfill material shall be placed in uniform horizontal layers of not more than 150 mm thickness. Small pebbles of size less than 50 mm, if any, shall be so distributed throughout the mass, that all interstices are solidly filled with fine material. The backfill material shall be tamped with mechanical tamping equipment like plate vibrator, after moistening the backfill by sprinkling with water to obtain maximum compaction.
10. Machine backfill shall be conducted so that the material deposited in the trench shall not fall directly on top of the pipe from such a height as might result in damage to the pipe joints or alignment.
11. If the trench is subjected to conditions, which might cause flotation of the pipe before sufficient backfill has been placed; the Contractor shall take the necessary precautions to prevent flotation of the pipe, conduit or structure.
12. Before final acceptance of the work, additional tamped earth shall be added to restore the settled trench surface to the required level of the adjacent earth surface or to the base of crushed rock wearing surface or to the finished earth base.
13. If from the excavated soil, enough backfill material is not available, imported, selected and approved backfill material from the borrow pits is required to be placed for backfill, on approval of the E in C at their own cost.

c) Compaction Test

The earth backfill (Sub grade) shall be consolidated to achieve at least 95% proctor density with respect to field density before excavation.

To ensure the fill has been compacted specified field and the contractor for checking the Optimum Moisture Content (O.M.C) at his cost shall carry out laboratory test.

The Contractor should carry out tests for density of backfill at his own cost and that if the backfill is found to be unsatisfactory, it shall be rectified or the backfilling will be got done by the other agencies at the cost of the Contractor.

Method of test for compaction shall be as directed by Engineer in charge (E in C).

19.3.4 Disposal of surplus excavated material

The excavated material which is in surplus to the requirements after backfilling shall be disposed off as directed by the E in C at Construction & debris plant at their own cost., at suitable site with all lead and lift for which no extra payment shall be made. The site is to be assessed by the Contractor and got approved by the Engineer.

19.4 Responsibility

Responsibility for various activities in pre-commissioning and commissioning procedures will rest with the Contractors.

19.4.1 Pipes Material

HDPE pipes PE100 & PN 8 shall be provided. Specifications of pipes shall be as per IS: 7634(Part-II) or as amended up to date using PE 100 grade raw material. The pipes should be handled carefully while loading, unloading, transporting and during laying and jointing at site.

(a.) Laying, Jointing and Testing

Providing, Laying, jointing, testing and commissioning of HDPE shall be as per IS: 4984-1995 and ISO 4427.

(b.) Marking

All pipes will be marked as below:

- (a) Manufacturer name/ stamp
- (b) Nominal diameter
- (c) Class reference
- (d) Lot number/Batch number

(c.) Specials for HDPE pipes

The following types of HDPE specials (10 KSC) shall be manufactured and tested in accordance with ISO 8008 specifications.

(d.) Jointing of the Pipes

Pipe joints shall be water tight and butt fusion jointing is carried out in HDPE Pipes conforming to IS: 14333-1996 specifications. The method requires field equipment's to hold the pipe and fittings in close alignment, melt the pipe, and join the pipe. Butt ends have to be faced, cleaned, melted, and fused together, then cooled under fusion parameters recommended by the supplier. Laying and jointing by butt fusion welding technology as per manufacturer recommendation.

(e.) Testing and commissioning

After the new pipe is laid, jointed and partially back filled hydraulic tests is to be carried out. Hydraulic test both at factory and at site as per latest IS: 4985 code of practice or 1.5 times the rated pressure whichever is higher.

Portions of the line shall be tested by subjecting the pressure test as the laying progresses before the entire line is completed (the test stretch should not generally exceed 500 m), to identify any error of workmanship which can be detected and corrected at minimum cost. For all these tests water of approved quality has to be arranged by the Contractor.

(f.) Measurement and payment

The length of the irrigation network pipes shall be measured in running meter for a particular pipe diameter along the centre line of pipe to the nearest centimetre. Measurement of specials for fittings shall be as per BOQ item.

The payment will be made per m length of pipe measured based on the quoted rates once the testing and backfilling is completed.

19.4.2 Bedding of the pipes

The trench bottom shall be even and smooth so as to provide a proper support for the pipe over its entire length, and shall be free from stones, lumps, roots and other hard objects that may injure the pipe or coating.

Laying of Jamuna sand bedding for pipe lines with carefully compacted in layers not more than 15 cm thick including ramming, watering, consolidating and dressing complete for pipe bedding and surrounding as per drawing and as directed by engineer in-charge. Holes shall be dug in the bedding bottom to accommodate sockets so as to ensure continuous contact between the trench and the entire pipe barrel between socket holes.

It is also essential that the soil is sufficiently compacted to develop uniform lateral passive soil pressure. Proper bedding is required to control deflection, which is the main criterion in design of plastic pipes.

19.5 Civil works

19.5.1 Site Clearance and rough grading

Before the start of the works, the entire site shall be cleared of all bushes, shrubs, jungle and unwanted vegetation growth etc., and made clean. The rubbish shall be disposed off as directed by the Engineer. After the site is cleared, it shall be roughly graded to even out any undulations or ditches present therein.

19.5.2 Materials

All materials used in the work shall be subjected to mandatory tests in accordance with relevant IS codes and as specified in specifications. Before incorporating the materials in the permanent Works, test reports shall be submitted to the E in C for seeking his permission.

19.5.3 FORM WORK

19.5.3.1 GENERAL

Formwork, shuttering, centering, scaffolding etc. shall be of steel plates or plywood, lined with MS-sheets and for scaffolding steel tubular shall be used. Joints should be sufficiently tied to prevent loss of cement slurry from the concrete. All forms, shuttering shall be leveled, aligned, and thoroughly cleaned, before they are used for concreting.

Formwork shall be removed after specified days of curing with the prior written permission of the E in C. The surface of RCC after removal of formwork / shuttering shall be smooth, even and without honeycombing or undulations.

19.5.3.2 BRACINGS, STRUTS AND PROPS:

Shuttering shall be braced, strutted, propped and so supported that it shall not deform under weight and pressure of the concrete and also due to the movement of men and other materials. Bamboos shall not be used as props or cross bracings. The shuttering for beams and slabs shall be so erected that the shuttering on the sides of beams and under the soffit of slab can be removed without disturbing the beam bottoms.

Re-propping of beams shall not be done except when props have to be reinstated to take care of construction loads anticipated to be in excess of the design load. Vertical props shall be supported on wedges or other measures shall be taken whereby the props can be gently lowered vertically while striking the shuttering.

If the shuttering for a column is erected for the full height of the column, one side shall be left open and built upon sections as placing of concrete proceeds, or windows may be left for pouring concrete from the sides to limit the drop of concrete to 1.0 m or as directed by Engineer-in-charge.

19.5.3.3 INSPECTION OF FORM WORK:

Following points shall be borne in mind while checking during erection of form work and formwork got approved by the Engineer-in-charge before placing of reinforcement bars

- a) Any member which is to remain in position after the general/ dismantling is done be cleanly marked.
- b) Material used should be checked to ensure that, wrong items/ rejects are not used.
- c) If there are any excavations nearby which may influence the safety of form works, corrective and strengthening action must be taken.
- d) (i) The bearing soil must be sound and well prepared and the sole plates shall bear well on the ground.
(ii) Sole plates shall be properly seated on their bearing pads or sleepers.
(iii) The bearing plates of steel props shall not be distorted.
(iv) The steel parts on the bearing members shall have adequate bearing areas.
- e) Safety measures to prevent impact of traffic; scour due to water etc should be taken. Adequate precautionary measures shall be taken to prevent accidental impacts etc.
- f) Bracing, struts and ties shall be installed along with the progress of form work to ensure strength and stability of form work at intermediate stage. Steel sections (especially deep sections) shall be adequately restrained against tilting, overturning and form work should be restrained against horizontal loads. All the securing devices and bracing shall be tightened.
- g) The stacked materials shall be placed as catered for, in the design.
- h) When adjustable steel props are used, they should:
 - (i) Be undamaged and not visibly bent
 - (ii) Have the steel pins provided by the manufacturers for use
 - (iii) Be restrained laterally near each end.
 - (iv) Have means for centralizing beams placed in the fork heads.
- i) Screw adjustment of adjustable props shall not be over extended.
- j) Double wedges shall be provided for adjustment of the form to the required position wherever any settlement / elastic shortening of props occur. Wedges should be used only at the bottom end of single prop. Wedges should not be too steep and one of the pair should be tightened / clamped down after adjustment to prevent other shifting.
- k) No member shall be eccentric upon vertical member
- l) The number of nuts and bolts shall be adequate
- m) All provisions of the design and / or drawings shall be complied with

- n) Cantilever supports shall be adequate
- o) Props shall be directly under one another in multistage constructions as far as possible.
- p) Guy ropes or stays shall be tensioned properly.

19.5.3.4 REUSE OF FORMS:

Before reuse, all forms shall be thoroughly scrapped, cleaned, nails removed, holes that may leak suitably plugged and joints examined and when necessary repaired and the inside retreated to prevent adhesion, to the satisfaction of Engineer-in-charge. Warped lumber shall be resized.

Contractor shall equip himself with enough shuttering to complete the job in the stipulated time.

19.5.4 Bricks

19.5.4.1 SCOPE OF WORK:

The work covered under this specification pertains to procurement of best quality locally available bricks and workmanship of walls of various thicknesses. In strict compliance with the specifications and applicable drawings.

19.5.4.2 MATERIAL:

First class Bricks shall be best quality locally available bricks and having strength 105 Kg/Sq.cm shall be got approved by the Engineer-in-charge before incorporation in the work.

The nominal size of bricks (F.P.S) shall be 22.9 X 11.4 X7cm (9" X 4 1/2 X 2 3/4"). Permissible tolerance on dimensions shall be + 3mm. in length and + 1.5 mm in width / thickness. The contractor shall get approved the sample and source of bricks from Engineer- in-charge before procurement on large scale and shall maintain the same for the entire work.

19.5.4.3 Workmanship:

1. Four courses of brickwork with four joints should not exceed by more than 40mm the same bricks piled one over the other without mortar.
2. Brickwork shall not be raised more than 10 courses a day unless otherwise approved by the Engineer-in-charge. The brickwork shall be kept wet for at least 7 days.
3. Brickwork shall be uniformly raised around and no part shall be raised more than 1.0 metre above another at any time.
4. All joints shall be thoroughly flushed with mortar of mix as specified in the schedule of quantities, at every course. Care shall be taken to see that the bricks are bedded effectively and all joints completely filled to the full depth.
5. The joints of brick work to be plastered shall be raked out to a depth not less than
6. 10mm as the work proceeds. The surface of brickwork shall be cleaned down and wiped properly before the mortar sets.

19.5.4.4 Mode of measurement:

For Brick work measured in Cubic Meters:

The contract rate shall be for a unit of one cubic metre of brick masonry as actually

Opening or chases required for P.H. or electrical inserts less than 0.1 sqm. and bearing of precast concrete members shall not be deducted.

No extra payment shall be made for any extra work involved in making the above openings or placements.

19.5.4.5 Reinforced Cement Concrete (RCC) Work

1. Water : Water used for cement concrete mortar, plaster, grout or curing shall be clear and free from injurious amounts of oils, acids, alkalies and other harmful substances in such amounts
2. The aggregates and cement shall be proportioned by weight only. The mixing shall always be carried out in mechanical mixer and in such a way so as to avoid any loss of water or cement. No hand mixed concrete will be allowed. It should be conveyed, placed in position and compacted by suitable type of mechanical vibrator, as rapidly as practicable but in no case the time of compaction after mixing shall increase 30 minutes. Standby concrete mixer and vibrator shall be available at site.
3. Ordinary Portland Cement (OPC) 53 Grade conforming to IS: 8112 mark shall only be used. Cement manufactured in mini-cement plants shall not be used.
4. All reinforcement used shall be of TMT bar (Fe 500) ISI mark and shall be clean and free from loose mill scales, rust and coating of oil or other coatings which may destroy or reduce bond.
5. Only steel shuttering shall be used. Shuttering shall be new or in a good condition without holes or dents. It has to be approved by the Engineer. The individual elements of shuttering shall be in the correct shape to ensure a gap free shuttering. Suitable systems have to be provided for keeping the shuttering in place and keeping the correct distance in case of walls.
6. The construction joints should be minimum and these have to be executed with utmost care. Before concreting on contact on joint loose material has to be removed and they have to be cleaned properly. Honeycombing has to be avoided by suitable fixing of shuttering and proper use of vibrators.
7. The exposed surfaces of concrete shall be kept continuously in a wet condition by ponding or covering with a layer of sackings, canvas or similar materials and kept continuously wet for at least 21 days from the date of placing of concrete.
8. To obtain dense concrete and to reduce chances of honey combing adequate vibrating and compacting shall be ensured.
9. RCC grade shall be as specified in the construction Drawings or as per Bill of Quantities (BOQ).

19.5.5 Cement

Cement to be used in the works shall be any of the following types with the prior approval of the Engineer.

These have to be procured from reputed ISO: 9000 organizations:

- i. Ordinary Portland cement, 43 Grade,
- ii. Ordinary Portland cement, 53 Grade, conforming to IS: 12269.

Cement conforming to IS: 8041 shall be used only for pre-cast concrete products after specific approval of the Engineer.

19.5.6 Coarse aggregates

For plain and reinforced cement concrete (PCC and RCC) works, coarse aggregate shall consist of clean, hard, strong, dense, non-porous and durable pieces of crushed stone or Kota stone or other approved inert material. They shall not consist of pieces of disintegrated stones, soft, flaky, elongated particles, salt, alkali, vegetable matter or other deleterious materials in such quantities as to reduce the strength and durability of the concrete, or to attack the steel reinforcement. Coarse aggregate having positive alkali silica reaction shall not be used. All coarse aggregates shall conform to IS: 383 and tests for conformity shall be carried out as per IS: 2386(Parts I to VIII).

Nominal size of coarse aggregate for various components in PCC & RCC is mentioned in BOQ. In case of discrepancy, the decision of the E in C is final.

19.5.7 Sand/Fine Aggregates

For masonry work, sand shall conform to the requirements of IS 2116.

For plain and reinforced cement concrete (PCC and RCC) works, fine aggregate shall consist of a suitable combination of natural sand. They shall not contain dust, lumps, soft or flaky, materials, mica or other deleterious materials in such quantities as to reduce the strength and durability of the concrete, or to attack the embedded steel. Sand washing machines should be used to remove impurities from sand. Fine aggregate having positive alkali-silica reaction shall not be used. All fine aggregate shall conform to IS: 383 and test for conformity shall be carried out as per IS: 2386 (Part I to VIII). The contractor shall submit to the Engineer the entire information indicated in Appendix A of IS: 383. The fineness modulus of fine aggregate shall neither be less than 2.0 nor greater than 3.5.

19.5.8 Water

Water used for mixing and curing shall be clean and free from injurious amounts of oils, acids, alkalis, salts, sugar, organic materials or other substances that may be deleterious to concrete or steel. Potable water is generally considered satisfactory for mixing concrete.

19.5.9 Cement mortar

Cement and sand shall be mixed in specified proportions given in the construction Drawings. Cement shall be proportioned by volume. The unit weight of cement shall 1.44 tons per cubic meter. Sand shall be proportioned by volume taking into account due allowance for bulking. All mortar shall be mixed with a minimum quantity of water to produce desired workability consistent with maximum density of mortar. The mix shall be clean and free from injurious type of soil/acid/alkali/organic matter or deleterious substances.

The mixing shall preferably be done in a mechanical mixer operated manually or by power. Hand mixing can be resorted to as long as uniform density of the mix and its strength are assured subject to prior approval of the E in C. Hand mixing operation shall be carried out on a clean water-tight platform, where cement and sand shall be first mixed dry in the required proportion by being turned over and over, backwards and forwards several times till the mixture is of uniform color. Thereafter, minimum quantity of water shall be added to bring the mortar to the consistency of a stiff paste. The mortar shall be mixed for at least two minutes after addition of water.

Mortar shall be mixed only in such quantity as required for immediate use. The mix which has developed initial set shall not be used. Initial set of mortar with ordinary Portland cement shall normally be considered to have taken place in 30 minutes after mixing. In case the mortar has stiffened during initial setting time because of evaporation of water, the same can be re-tempered by adding water as frequently as needed to

restore the requisite consistency, but this re-tampering shall not be permitted after 30 minutes. Mortar unused for more than 30 minutes shall be rejected and removed from site of work.

19.5.10 Curing

Brick work shall be protected from rain by suitable covering and shall be kept constantly moist on all faces for a minimum period of seven days. Brick work carried out during the day shall be suitably marked indicating the date on which the work is done so as to keep a watch on the curing period. Top of the masonry work shall be left flooded with water at the close of the day. Watering may be done carefully so as not to disturb or wash out the green mortar.

During hot weather, all finished or partly completed work shall be covered or wetted in such a manner as will prevent rapid drying of the brickwork.

During the period of curing of brick work, it will be suitably protected from all damages. At the close of day's work or for other period of cessation, watering and curing shall have to be maintained. Should the mortar perish i.e., become dry, white or powdery, through neglect of curing, work shall be pulled down and rebuilt as directed by the Engineer. If any stains appear during watering, the same shall be removed from the face.

19.5.11 Steel

19.5.11.1 Reinforcement

For reinforced cement concrete (RCC) works, the reinforcement / intended steel as the case may be shall consist of the following grades of reinforcing bars:

All steel shall be procured from original producers, or their authorized distributors.

Only new steel shall be delivered to the site. Every bar shall be inspected before assembling on the work and defective, brittle or burnt bar shall be discarded. Cracked ends of bars shall be discarded.

Whenever specified, either in construction drawings or BOQ, reinforcement steel i.e. high yield strength deformed bars of Fe500D. Utmost care should be taken so that bars are not damaged during handling and transportation.

19.5.11.2 Structural steel

Unless otherwise permitted herein, all structural steel shall before fabrication comply with the required specifications as per Indian Standards. If any standard is not specified in the BOQ then materials has to be procured after getting the approval from FSCL Engineer-In-Charge.

19.5.11.3 Stone: Red Agra Stone /Kota Stone:

19.5.11.4 SCOPE

This specification includes fabricated Red Agra Stone / Kota stone components required for the completion of Kota stone work indicated in the BOQ.

19.5.11.5 Source of Supply

All Red Agra Stone / Kota Stone shall be obtained from quarries having adequate capacity and facilities to meet the specified requirements. Fabrication shall be by a firm equipped to process the material promptly in accordance with specifications. Evidence to this effect shall be provided by the supplier if required by the Design Professional.

19.5.11.6 Samples

Sufficient samples of Red Agra Stone / Kota Stone shall be submitted to the Design Professional through the General Contractor.

Each sample set shall include three samples.

Sample set shall show anticipated range of color, natural variations of grain structure, inclusions and any other visual characteristics to be expected in the final installation.

Approved sample set shall establish the standard by which stonework will be judged.

19.5.11.7 Shop Drawings

The Red Agra Stone / Kota Stone supplier shall submit: copies of required shop drawings to the Design Professional for approval. These drawings shall show all bedding, bonding, jointing and anchoring details, and the dimensions of each piece of Red Agra Stone / Kota Stone. No final sizing or finishing shall be done until the shop drawings for that part of the work has been approved.

19.5.11.8 Defective Work

Any piece of Red Agra Stone / Kota Stone showing manufacturing flaws upon receipt at the storage yard or building site shall be referred to the Design Professional for determination as to whether it shall be rejected, patched or redressed for use.

19.6 Materials

(1) CEMENT CONCRETE FLOORING

Cement Concrete: Cement concrete of specified mix grade shall be used and it shall generally conform to the specifications described under HSR

(2) Base Concrete : Flooring shall be laid on base concrete where so provided. The base concrete shall be provided with the slopes required for the flooring. Flooring shall have slope ranging from 1 : 48 to 1 : 60 depending upon location and as decided by the Engineer-in-Charge.

(3) The flooring shall be commenced preferably within 48 hours of the laying of base concrete. The surface of the base shall be roughened with steel wire brushes without disturbing the concrete. Immediately before laying the flooring, the base shall be wetted and a coat of cement slurry @ 2 kg of cement spread over an area of one sqm so as to get a good bond between the base and concrete floor.

(4) If the cement concrete flooring is to be laid directly on the RCC slab, the top surface of RCC slab shall be cleaned and the laitance shall be removed and a coat of cement slurry @ 2 kg of cement spread over an area of one sqm so as to get a good bond between the base and concrete floor.

(5) Thickness

The thickness of floor shall be as specified in the description of the item.

(6) Laying

(7) Panels: Flooring of specified thickness shall be laid in the pattern including the border as given in the drawings or as directed by the Engineer-in-Charge. The border panels shall not exceed 450 mm in width and the joints in the border shall be in line with panel joints. The panels shall be of uniform size and no dimension of a panel shall exceed 2 m and the area of a panel shall not be more than 2 sqm.

The joints of borders at corners shall be mitred for provision of strips.

(8) Laying of Flooring with Strips : Normally cement concrete flooring shall be laid in one

operation using glass/aluminum/PVC/brass strips/stainless steel strips or any other strips as required as per drawing or instructions of the Engineer-in-Charge, at the junction of two panels. This method ensures uniformity in colour of all the panels and straightness at the junction of the panels. 4 mm thick glass strips or 2 mm PVC strips or 2 mm aluminum or brass strips shall be fixed with their tops at proper level, giving required slopes. Use of glass and metallic strips shall be avoided in areas exposed to sun. Cost of providing and fixing strips shall be paid for separately.

(9) Concreting: Cement concrete shall be placed in the panels and be leveled with the help of straight edge and trowel and beaten with thapy or mason's trowel. The blows shall be fairly heavy in the beginning but as consolidation takes place, light rapid strokes shall be given. Beating shall cease as soon as the surface is found covered with a thin layer of cream of mortar. The evenness of the surface shall be tested with straight edge. Surface of flooring be true to required slopes. While laying concrete, care shall be taken to see that the strips are not damaged/disturbed by the laborers. The tops of strips shall be visible clearly after finishing with cement slurry.

(10) Laying of Flooring without Strips: Laying of cement concrete flooring in alternate panels may be allowed by the Engineer-in-Charge in case strips are not to be provided.

(11) Shuttering : The panels shall be bounded by angle iron or flats. The angle iron/flat shall have the same depth as the concrete flooring. These shall be fixed in position, with their top at proper level giving required slopes. The surface of the angle iron or flats, to come in contact with concrete shall be smeared with soap solution or non-sticking oil (Form oil or raw linseed oil) before concreting. The flooring shall butt against the unplastered masonry wall.

(12) Concreting : The concreting shall be done in the manner described above. The angle iron/ flats used for shuttering, shall be removed on the next day of the laying of cement concrete. The ends thus exposed shall be repaired, if damaged with cement mortar 1 : 2 (1 cement : 2 coarse sand) and allowed to set for minimum period of 24 hours. The alternate panels shall then be cleaned of dust, mortar, droppings etc. and concrete laid. While laying concrete, care shall be taken to see that the edges of the previously laid panels are not damaged and fresh mortar is not splashed over them. The joints between the panels should come out as fine straight lines.

(13) Finishing

a. The finishing of the surface shall follow immediately after the cessation of beating. The surface shall be left for some time, till moisture disappears from it or surplus water can be mopped up. Use of dry cement or cement and sand mixture stiffening the concrete to absorb excessive moisture shall not be permitted. Excessive trowelling shall be avoided.

b. Fresh cement shall be mixed with water to form a thick slurry and spreaded @ 2 kg of cement over an area of one sqm of flooring while the flooring concrete is still green. The cement slurry shall then be properly processed and finished smooth.

c. The men engaged on finishing operations shall be provided with raised wooden platform to sit on so as to prevent damage to new work.

(14) Curing

The curing shall be done for a minimum period of ten days. Curing shall not be commenced until the top layer has hardened. Covering with empty gunnies bag shall be avoided as the colour of the flooring is likely to be bleached due to the remnants of cement dust from the bags.

(15) Precautions

During cold weather, concreting shall not be done when the temperature falls below 4°C. The

Concrete placed shall be protected against frost by suitable covering. Concrete damaged by frost shall be removed and work redone. During hot weather, precautions shall be taken to see that the temperature of wet concrete does not exceed 38° C. No concreting shall be laid within half an hour of the closing time of the day, unless permitted by the Engineer-in-Charge.

19.7 KOTA STONE FLOORING

(1) Kota Stone Slabs

The slabs shall be of selected quality, hard, sound, dense and homogeneous in texture free from ricks, decay, weathering and flaws. They shall be hand or machine cut to the requisite thickness. They shall be of the colour indicated in the drawings or as instructed by the Engineer-in-Charge.

The slabs shall have the top (exposed) face polished before being brought to site, unless otherwise specified. The slabs shall conform to the size required. Before starting the work the contractor shall get the samples of slabs approved by the Engineer-in-Charge.

(2) Dressing

Every slab shall be cut to the required size and shape and fine chisel dressed on the sides to the full depth so that a straight edge laid along the side of the stone shall be in full contact with it. The sides (edges) shall be table rubbed with coarse sand or machine rubbed before paving. All angles and edges of the slabs shall be true, square and free from chippings and the surface shall be true and plane. The thickness of the slab after it is dressed shall be 20, 25, 30 or 40 mm as specified in the description of the item. Tolerance of ± 2 mm shall be allowed for the thickness. In respect of length and breadth of slabs Tolerance of ± 5 mm for hand cut slabs and ± 2 mm for machine cut slabs shall be allowed.

(3) Preparation of Surface and Laying

Base concrete or the RCC slab on which the slabs are to be laid shall be cleaned, wetted and mopped. The bedding for the slabs shall be with cement mortar 1:4 (1 cement: 4 coarse sand) or as given in the description of the item.

The average thickness of the bedding mortar under the slab shall be 20 mm and the thickness at any place under the slab shall be not less than 12 mm.

The slabs shall be laid in the following manner:

Mortar of the specified mix shall be spread under the area of each slab, roughly to the average

thickness specified in the item. The slab shall be washed clean before laying. It shall be laid on top,

pressed, tapped with wooden mallet and brought to level with the adjoining slabs. It shall be lifted and laid aside. The top surface of the mortar shall then be corrected by adding fresh mortar at hollows. The mortar is allowed to harden a bit and cement slurry of honey like consistency shall be spread over the

same at the rate of 4.4 kg of cement per sqm. The edges of the slab already paved shall be buttered with grey or white cement with or without admixture of pigment to match the shade of the marble slabs as given in the description of the item.

Stone slabs to be paved shall then be lowered gently back in position and tapped with wooden mallet till it is properly bedded in level with and close to the adjoining slabs with as fine a joint as possible.

Subsequent slabs shall be laid in the same manner. After each slab has been laid, surplus cement on the surface of the slabs shall be cleaned off. The flooring shall be cured for a minimum period of seven days. The surface of the flooring as laid shall be true to levels, and, slopes as instructed by the

Engineer-in-Charge. Joint thickness shall not be more than 1 mm. Due care shall be taken to match the grains of slabs which shall be selected judiciously having uniform pattern of Veins/streaks or as directed by the Engineer-in-Charge.

The slabs shall be matched as shown in drawings or as instructed by the Engineer-in-Charge.

Stone slabs which are fixed in the floor adjoining the wall shall enter not less than 12 mm under the plaster skirting or dado. The junction between wall plaster and floor shall be finished neatly and without waviness.

Stone slabs flooring shall also be laid in combination with other stones and/or in simple regular pattern/design as described in item of work and/or drawing.

The edges of the slabs to be jointed shall be buttered with grey cement, with admixture of pigment to match the shade of the slab. The thickness of the joints should be minimum as possible. In any location, it shall not exceed 1 mm.

(4) Polishing and Finishing

The specifications shall be as described above except that (a) first polishing with coarse grade carborundum stone shall not be done, (b) cement slurry with or without pigment shall not be applied on the surface before polishing.

19.8 RED OR WHITE FINE DRESSED SAND STONE FLOORING

(1) Stone Slabs

The slabs shall be red or white as specified in the description of the item. The stone slabs shall be hard, sound, durable and tough, free from cracks, decay and weathering. In case of red sand stone, white patches or streaks shall not be allowed. However, scattered spots upto 10 mm diameter will be permitted. Before starting the work the contractor shall get samples of slabs approved by the Engineer-in-Charge.

The slabs shall be hand or machine cut to the requisite thickness along planes parallel to the natural bed of stone and should be of uniform size if required.

(2) Dressing of Slabs

Every slab shall be cut to the required size and shape and chisel dressed on all sides to a minimum depth of 20 mm. The top and the joints shall be fine tooled so that straight edge laid along the face is fully in contact with it. In case machine cut stones are used, chisel dressing and fine tooling of machine cut surface need not be done provided a straight edge laid anywhere along the machine cut surface is in contact with every point on it.

The thickness of the slabs after dressing shall be 40 mm or as specified in the description of item with a permissible tolerance of ± 2 mm.

(3) Laying

Base concrete on which the slabs are to be laid shall be cleaned, wetted and mopped. The bedding for the slabs shall be with cement mortar 1:5 (1 cement : 5 coarse sand) or as given in the description of the item.

The average thickness of the bedding mortar under the slabs shall be 20 mm and the thickness at any place under the slabs shall not be less than 12 mm.

The slab shall be laid in the following manner:

Mortar of specified mix shall be spreaded under each slab. The slab shall be washed clean before laying. It shall then be laid on top, pressed and larried, so that all hollows underneath get filled and surplus mortar works up through the joints. The top shall be tapped with a wooden mallet and brought to level and close to the adjoining slabs, with thickness of joint not exceeding 5 mm. Subsequent slabs shall be laid in the same manner. After laying each slab surplus mortar on the surface of slabs shall be cleaned off and joints finished flush.

In case pointing with other mortar mix is specified, the joint shall be left raked out uniformly and to a depth of not less than 12 mm when the mortar is still green. The pointing shall be cured for a minimum period of 7 days. The surface of the flooring as laid shall be true to levels and slopes as instructed by the Engineer-in-Charge.

Slabs which are fixed in the floor adjoining the wall shall enter not less than 12 mm under the plaster, skirting or dado. The junction between wall plaster skirting and floor shall be finished neatly and without waviness.

The finished floor shall not sound hollow when tapped with wooden mallet.

(4) Finishing

In case of chisel dressed stone flooring slight unevenness, if any existing between the edges of slabs at joints shall then be removed by chiselling in a slant.

19.9. RED OR WHITE FINE DRESSED AND RUBBED SAND STONE FLOORING

(1) Stone Slabs shall be as specified in fine dressed stone slabs for red and stone flooring.

(2) Dressing

The specifications for dressing the top surface and the sides shall be as described in fine dressed stone slabs for red and stone flooring in addition the dressed top and sides shall be table rubbed with coarse grade carborundum stone before paving, to obtain a perfectly true and smooth surface free from chisel marks. The thickness of the slabs after dressing shall be as specified with a permissible tolerance of ± 2 mm.

(3) Laying

The slabs shall be laid with 3 mm thick or 5 mm thick joints as specified in the description of the item.

Where the joints are to be limited to 3 mm thickness, the slabs shall be laid as specified above for stone work except that the bedding mortar shall be as specified in fine dressed stone slabs and sides of the slabs to be jointed shall be buttered with cement mortar 1:2 (1 cement : 2 stone dust) admixed with pigment to match the shade of the slab.

Where the slabs are to be laid with 5 mm thick joints, the specifications for laying shall be as described in fine dressed stone slabs.

(4) Finishing shall be as specified in for fine dressed stone slabs except that chisel marks and unevenness shall be removed by rubbing with coarse grade carborundum stone.

19.10 KOTA / RED SAND STONE IN RISERS OF STEPS, SKIRTING AND DADO

19.10.1 Kota / Red sand Stone Slabs and Dressing shall be as specified above except that the thickness of the slabs shall be 25 mm or as specified in the description of the item. The slabs may be of uniform size if required.

19.10.2 Preparation of surface

The joints shall be raked out to a depth of at least 15 mm in masonry walls. In case of concrete walls, the surface shall be hacked and roughened with wire brushes. The surface shall be cleaned thoroughly, washed with water and kept wet before skirting is commenced. where necessary, the wall surface shall be cut uniformly to the requisite depth so that the skirting face shall have the projection from the finished face of wall as shown in drawings or as required by the Engineer-in-Charge. In no case the skirting should project by more than thickness of stone.

19.10.3 Laying

The risers of steps and skirting shall be in grey or white cement admixed with or without pigment to match the shade of the stone, as specified in the description of the item, with the line of the slab at such a distance from the wall that the average width of the gap shall be 12 mm and at no place the width shall be less than 10 mm, if necessary, the slabs shall be held in position by temporary M.S. hooks fixed into the wall at suitable intervals. The skirting or riser face shall be checked for plane and plumb and corrected. The joints shall thus be left to harden then the rear of the skirting or riser slab shall be packed with cement mortar 1:3 (1 cement : 3 coarse sand) or other mix as specified in the description of the item. The fixing hooks shall be removed after the mortar filling the gap has acquired sufficient strength.

The joints shall be as fine as possible but not more than 1 mm. The top line of skirting and risers shall be truly horizontal and joints truly vertical, except where otherwise indicated.

The risers and skirting slab shall be matched as shown in drawings or as instructed by the Engineerin- in Charge.

The joints of the slabs shall be set in grey cement mixed with pigment to match the shade of the slabs.

19.10.4 Curing, Polishing and Finishing

The day after the stone are laid all joints shall be cleaned of the grey cement grout with a wire brush or trowel to a depth of 5 mm and all dust and loose mortar removed and cleaned. Joints shall then be grouted with grey or white cement mixed with or without pigment to match the shape of the topping of the wearing layer of the stone. The same cement slurry shall be applied to the entire surface of the stone in a thin coat with a view to protect the surface from abrasive damage and fill the pin holes that may exist on the surface.

The floor shall then be kept wet for a minimum period of 7 days. The surface shall thereafter be grounded evenly with machine fitted with coarse grade grit block (No. 60). Water shall be used profusely during grinding. After grinding the surface shall be thoroughly washed to remove all grinding mud, cleaned and mopped. It shall then be covered with a thin coat of grey or white cement, mixed with or without pigment to match the colour of the topping of the wearing surface in order to fill any pin hole that appear. The surface shall be again cured. The second grinding shall then be carried out with machine fitted with fine grade grit block (No. 120).

The final grinding with machine fitted with the finest grade grit blocks (No. 320) shall be carried out the day after the second grinding described in the preceding para or before handing over the floor, as ordered by the Engineer-in-Charge.

For small areas or where circumstances so require, hand grinding/polishing with hand grinder may be permitted in lieu of machine polishing after laying. For hand polishing the following carborundum stones, shall be used:

1st grinding — coarse grade stone (No. 60)

Second grinding — medium grade (No. 80)

Final grinding — fine grade (No. 120)

In all other respects, the process shall be similar as for machine polishing.

After the final polish, oxalic acid shall be dusted over the surface at the rate of 33 gm per square metre sprinkled with water and rubbed hard with a 'namdah' block (pad of woollen rags). The following day the floor shall be wiped with a moist rag and dried with a soft cloth and finished clean.

If any tile is disturbed or damaged, it shall be refitted or replaced, properly jointed and polished.

Cement slurry with or without pigment shall not be applied on the surface and polishing shall be done only with hand. The face and top of skirting shall be polished.

19.11 COLOURED CONCRETE

The top surface of concrete shall be applied with Color Hardener at the rate of 2.7 kgs/sq mtr. The surface shall be treated with different types of floaters, application of Release Agent at the rate of 0.113 kg/sq.mtr, cleaning the surface with water and application of acrylic based Sealer for finishing. Color hardeners and release agents have been tested for abrasion resistance and should have a depth of wear not greater than 0.05mm under BS 8204.

Color Hardener shall be added to the cement. It shall be a blend of three principal ingredients: mineral oxide pigments cement and graded silica aggregates. Special conditioning admixtures are also included to improve workability.

Release Agent shall be added which is a dry blend of chemical powders and color pigments designed for use in the process to allow the clean release of texturing tools from the concrete surface.

19.11.1 Preparation of surface

Preparation work includes sub-grade preparation, finish grading, constructing formwork, placing and setting screeds, and furnishing and placement of reinforcement.

19.11.2 Laying

The concrete shall have a minimum compressive strength of 3,000 psi in non-freeze areas, 3,500 psi in moderate freeze-thaw areas and 4,000 psi in severe freeze-thaw areas. Portland cement shall conform to ASTM C 150 Type I, II, or V, depending on soil conditions. Aggregates shall conform to ASTM C 33. Mixing water shall be fresh, clean and potable. In freeze-thaw areas only, an air-entraining admixture complying to ASTM C 260 shall be used to achieve entrained air content for the particular mix .No admixtures containing calcium chloride shall be permitted.

The concrete shall be colored with the Hardener color.The grade of the hardener shall be: Regular Grade or Heavy Duty Grade. The Release Agent color shall be applied to all concrete surfaces to be imprinted and textured.

Color Hardener shall be applied evenly to the surface of the fresh concrete by the dry-shake method using a minimum of 60 pounds per 100 square feet/27 kilograms per 9 square meters. It shall be applied in two or more shakes, floated after each shake and troweled only after the final floating. Release Agent shall be applied evenly to the troweled surface prior to imprinting. Bomacron Release Agent shall be applied evenly to the troweled surface prior to imprinting.

20 SUPPLYING AND LAYING PAVER BLOCK 60 mm

20.1 PERFORMANCE BASED SPECIFICATIONS:

The following is a Performance based Specification which relates to the supply and laying of Paver blocks.

20.1.1 Methodology and Sequence of Work

The Contractor shall not commence any Hardscape work until the following have been completed:

- a. All in ground drainage completed
- b. All Kerb edge restraints completed
- c. All other in ground services laid and complete
- d. All areas surveyed and string lines set to establish the final finished level.
- e. Any pre-existing manhole covers or drainage covers adjusted and raised or lowered to conform to the final finished Pavement Level.
- f. The Contractor shall submit a full methodology, setting out his proposed sequence of work and trade before commencing paver blocks laying works.

20.1.2 Setting Out

- a. The Contractor shall achieve the formation levels required for paving.
- b. The line and levels of the paved areas shall be carefully set out in accordance with the Contract Drawings and be frequently checked by the Contractor, care being taken to ensure that correct gradients and cross falls are achieved.
- c. The finished gradients of all pavements shall be formed so as to provide adequate falls for drainage as shown on the Contract Drawings.

20.1.3 Storage

Paving materials shall be stored in a place on-site, as agreed with the Engineer-In-Charge. Supply to site shall be timed to minimize the required storage period for all materials. Method of storage shall avoid damage to all materials. Damaged units shall be replaced by the Contractor at his expense.

Due care should be taken to handle all units in a manner that will keep the risk of strain and deformation to a minimum.

20.1.4 Cutting

All paving materials requiring cutting shall be cut using a diamond blade bench saw to give an acceptable quality edge to the satisfaction of the Engineer-In-Charge. A sample of cutting must be approved by the Engineer-In-Charge prior to any cutting taking place on site.

Paving materials showing a jagged or irregular edge will be rejected by the Engineer-In-Charge and must be replaced to the approval of the Engineer-In-Charge entirely at the Contractors expense. The Contractor must allow for the periodic replacement of blades in cutting equipment to ensure clean cut edges to paving units.

20.1.5 Trip Hazard

A trip hazard is defined as any deviation in the pavement by $\pm 10\text{mm}$, including failure to adapt the finished levels to any pre-existing manhole cover or grating. The Contractor shall, therefore, carefully survey all

areas to be paved, prior to commencing work. On completion of the works, the Completed hardscape shall be carefully inspected for any Trip Hazards and these shall be rectified entirely at the Contractor's cost.

20.1.6 Construction in Inclement Weather

All newly laid paving shall be protected against the harmful effects of weather until such a time as the work is completed to the approval of the Engineer-In-Charge. Areas of paving damaged by inclement weather prior to Completion shall be replaced entirely at the Contractor's expense.

20.1.7 Sample Areas

The Contractor shall lay a 2.0 x 2.0 meter sample section of each paving type together with edge restraints and drainage furniture and obtain the approval of the Engineer-In-Charge before proceeding with laying of each of the paving types. The size, unless outlined in this Specification, and location of the sample area shall be agreed with the Engineer-In-Charge. Sample panels may be incorporated into the completed works by prior agreement with the Engineer-In-Charge.

20.1.8 Finished Levels of all Hardscape Surfaces

The finished level of the Hardscape surfaces is to be shown on the General Arrangement drawings. However, these are indicative only and the Contractor shall always extend a string line between edge restraints to establish smooth flowing gradients. The Contractor shall allow for in his rates the readjustments, raising, or lowering of any pre-existing manhole (of any type) that may be required in order to achieve the finished levels. The Contractor may in situation, readjust the finished level of the Hardscape areas, to match a pre-existing manhole, cover, or grating, provided prior consent is given by the Engineer-In-Charge

20.1.9 Finishing Work against all Items of Lighting Poles, Manhole and Drainage Covers.

The Contractor shall extend his Hardscape finishes right up to the edge of all items of Lighting Poles, Manhole and Drainage Covers. Cement mortar filler pieces in excess of 25mm wide shall be rejected and the Contractor shall make all efforts to ensure a neat, crisp and seamless joint.

20.1.10 Protection of the Completed Work

The Contractor shall protect and barricade off all areas of completed Hardscape upon completion, until Handover to the Client. The Contractor shall be responsible for ensuring that the works are handed over in a clean and tidy condition, and any staining in the completed Hardscape will be rejected.

20.2 LAYING OF INTERLOCKING PAVERS

All pavers shall be of approved brand and manufacturer – Pave Espania, Super Tiles or KJS makes approved by FSCL.

20.2.1 Characteristics

Concrete pavers shall be of M30 grade concrete, precast, and 60mm thickness. Tolerance in dimension allowed is ± 2 mm.

Edge restraint Blocks & kerbs shall be used at the edge of the pavement or as indicated in the drawings. They form a

Frame to the pavement that gives it definition & shape. Rectangular kerbs of size 200 x 100 x 60mm thick shall be used

as edge strip.

Shape	As per client's Drawing/BOQ
Edges	Chamfered
Application	Walkway, Driveway
Thickness	60 mm
Compressive Strength /finish	200 kg/cm ² ,300 kg/cm ² ,300-500kg/cm ² . Smooth, Coarse.
No. Of layers	Two
Top Layer	1:1
Bottom Layer	Design mix as per strength criteria.(M-40)
Bed preparation	WBM or lean P.C.C. (1:4:8 or 1:5:10) 75 mm thick.
Fixing Medium	Mortar 25 mm (1:6) or 40mm sand with vibratory Compaction.
Slope / Gradient	Adequate (Minimum 1% preferably 2%)
Grouting	Dry Grouting
Edge Restraint	Kerbstone or Retaining wall.
Abrasion Resistance	Less than 3.
Water Absorption	Less than 7% (After 24 Hrs.)

20.2.2 Sand Bedding

The paving blocks are indicated in the Contract Drawings to be bedded on sand (flexible paving) this material shall be naturally occurring sand or shall consist of crushed rock or gravel or a combination thereof with naturally occurring sand, hard, clean, free from all adherent coatings. It shall comply in all respects with relevant Indian Standards and be well graded down from 5mm.

The moisture content of the laying course should be as uniform as possible and at or about its optimum. Where material is to be stockpiled it should be covered.

The laying course should be such that, after compaction, it forms a nominally uniform layer, 20mm thick below the pavers.

The material should be spread loose in a uniform layer and screeded to a thickness required to give nominal 20mm layer after completion of the paving or the material should be spread in a loose, uncompacted layer to approximately 2/3rd of the required final thickness. This layer should be lightly compacted by means of a vibrating plated compactor. A further layer of loose material should be spread and screeded to create a loose surface on to which the units can be placed.

Care should be taken to avoid localized disturbance of the prepared laying course sand by pedestrian or wheeled traffic prior to placing units. The area of laying course prepared should be such that the position of its boundary is not more than one meter from the position of the laying face at the end of the working period wherever practicable.

20.2.3 Joints in Flexible Paving

Joints are to be 2mm when placed hand-tight. Pavers shall be laid working from an existing laying face edge or edge restraint. Full pavers should be laid first; closure units should then be laid. The area to be laid should be completed as far as is possible in entire paver units. Wherever possible, infilling to boundaries and obstructions should proceed as the laying of the surface course proceeds and infilling should be completed before compaction commences. Mechanical force shall not be used to obtain tight joints.

For flexible paving sand shall be brushed into the joints until they are filled to the top surface of the paving blocks. Sand for joint filling should be dry with a minimum particle size no greater than 1.18mm containing about 10% by weight passing a 0.75mm sieve. Sand colour shall be agreed with Engineer-In-Charge prior to brushing into joints.

The Contractor shall allow for cutting units to achieve laying to curves (without opening up joints).

20.2.4 Laying Pavers

Laying of paver blocks:

- 1) Paver blocks shall be laid in pattern throughout the pavement. Once the laying pattern has been established, it shall continue without interruption over the entire pavement surface. Cutting of blocks, the use of infill concrete or discontinuities in laying pattern is not to be permitted in other than approved locations.
- 2) Paver blocks shall be placed on the un-compacted screened sand bed to the nominated laying pattern, care being taken to maintain the specified bond throughout the job. The first row shall be located next to an edge restraint.
- 3) Specially manufactured edge paving blocks are permitted or edge blocks may be cut using a power saw, a mechanical or hydraulic guillotine, bolster or other approved cutting machine.
- 4) Paver blocks shall be placed to achieve gaps nominally 2 to 3 wide between adjacent paving joints. No joint shall be less than 1.5 mm and not more than 4 mm.
- 5) Frequent use of string lines shall be used to check alignment. In this regard the "laying face" shall be checked at least every two metres as the face proceeds.
- 6) Should the face become out of alignment, it must be corrected prior to initial compaction and before further laying job is proceeded with.
- 7) In each row, all full blocks shall be laid first. Closure blocks shall be cut and fitted subsequently. Such closure blocks shall consist of not less than 25 % of full blocks.
- 8) To infill spaces between 25 mm and 50 mm wide concrete having screened sand, coarse aggregate mix and strength of 45 N/sq.mm shall be used. Within such mix the nominal aggregate size shall not exceed one third the smallest dimension of the infill space. For smaller spaces dry packed mortar shall be used. Except where it is necessary to correct any minor variations occurring in the laying bond, the paver blocks shall not be hammered into position. Where adjustment of paver blocks, necessary care shall be taken to avoid the premature compaction of the sand bedding.

Initial Compaction:

- 9) After laying the paver blocks, they shall be compacted to achieve consolidation of the sand bedding and brought to design levels and profiles by not less than two (2) passes of a suitable plate compactor.
- 10) The compactor shall be a high-frequency, low amplitude mechanical flat plate vibrator having plate area sufficient to cover a minimum of twelve paving blocks.
- 11) Prior to compaction all debris shall be removed from the surface. Compaction shall proceed as closely as possible following laying and prior to any traffic. Compaction shall not, however, be attempted within one metre of the laying face. Compaction shall continue until lipping has been eliminated between adjoining blocks. Joints shall then be filled and recomputed as described in relevant Clause.
- 12) All work further than one metre from the laying face shall be left fully compacted at the completion of each day's laying.

13) Any blocks that are structurally damaged prior to or during compaction shall be immediately removed and replaced.

14) Sufficient plate compactors shall be maintained at the paving site for both bedding compaction and joint filling.

20.2.5 Cutting Pavers

Paving blocks requiring cutting shall be cut using a diamond blade bench saw to give an acceptable quality edge to the satisfaction of the Engineer-In-Charge and prior to general cutting taking place on site.

Pavers shall be cut to form neat junctions/boundaries with other paving materials/kerbs, street furniture, etc. fillets of colour matched mortar in lieu of small pieces of unit paving shall be avoided where possible and only be used with the approval of the Engineer-In-Charge.

Paving blocks showing a jagged or irregular edge will be rejected by the Engineer-In-Charge and must be replaced to the satisfaction of the Engineer-In-Charge all at the Contractor's expense.

Care shall be taken to avoid placing more than one cut kerb and/or paver unit in close proximity to another cut unit at junctions/changes of direction of paving.

The Contractor must allow for the periodic replacement of blades in cutting equipment to ensure clean cut edges to paving units.

20.2.6 Compaction of Flexible Paving

Pavers on sand bed shall be subjected to passes of a steel-faced vibrating plate compactor to adequately compact the laying course and to bed and regulate the paving blocks. The vibrating-plate compactor shall have a centrifugal force of 16-20KN, a plate area of 0.35-0.5 sqm and a frequency of 75-100Hz. Enough passes shall be made to compact the paving course and produce an even surface. All trimming should be completed before the area is compacted.

Compaction should follow laying as soon as possible but should not be carried out within 1m of the laying edge. Apart from this edge strip no area of paving should be left without being compacted at the completion of the day's work. The E in C approval must be obtained if compaction is not to be completed at the end of the day's work.

20.2.7 Finished Levels

Finished levels of the paving units shall not deviate by more than 2mm against adjacent units whilst the deviation from the design profile measured under a 3m straight edge should not exceed 10mm. The units shall form neat junctions with and prevent damage to adjacent work.

20.2.8 Cleaning on Completion of Work

On completion the face of the units must be clear of all dust, rust and other stains, adhering mortar and other droppings. Any units from which stains cannot be removed shall be replaced at the Contractor's expense and be to the approval of the E in C.

Flexible paving surfaces are to be brushed down with a soft bristle brush with joints refilled with sand where required. The paved areas must be left in a neat and tidy condition to the satisfaction of the Engineer-In-Charge.

20.3 Subgrade

All sub-grades shall be constructed in accordance with the requirements of this section and in conformity with the lines, grades, and cross-sections as shown in the contracted drawing listed in Appendix A or as directed by the Engineer.

20.3.1 Materials and General Requirements

20.3.1.1 Physical requirements

The materials used in sub-grades shall be soil, murrum, gravel, a mixture of these or any other material approved by the Engineer. Such materials shall be free of logs, stumps, roots, rubbish or any other ingredient likely to deteriorate or affect the stability of the sub-grade.

The following types of material shall be considered unsuitable for sub-grade:

- a. Materials from swamps, marshes and bogs;
- b. Peat, log, stump and perishable material; any soil that classifies as OL,OI, OH or Pt in accordance with IS:1498;
- c. Materials susceptible to spontaneous combustion;
- d. Materials in a frozen condition;
- e. Clay having liquid limit exceeding 70 and plasticity index exceeding 45; and
- f. Materials with salts resulting in leaching in the embankment.

Expansive clay exhibiting marked swell and shrinkage properties (“free swelling index” exceeding 50 per cent when tested as per IS:2720-part 40) shall not be used as a fill material. Whereas expansive clay with acceptable “free swelling index” value can be used as a fill material.

Any fill material with a soluble sulphate content exceeding 1.9 grams of sulphate (expressed as SO₃) per litre when tested in accordance with BS:1377 (Test 10), but using a 2:1 water-soil ratio shall not be used as a sub-grade.

Materials with a total sulphate content (expressed as SO₃) exceeding 0.5 percent by mass, when tested in accordance with BS:1377 (Test 9) shall also not be used as a sub-grade.

The size of coarse material in the mixture of earth shall ordinarily not exceed 50mm when placed in the sub-grade. However, the Engineer may at his discretion permit the use of material coarser than this also if he is satisfied that the same will not present any difficulty as regards the placement of fill material and its compaction to the requirements of these specifications. The maximum particle size shall not be more than two-thirds of the compacted layer thickness.

Ordinarily, only the materials satisfying the density requirements given in Table No. 1 shall be employed for the construction of the sub-grade.

Table 1 DENSITY REQUIREMENTS OF SUBGRADE MATERIALS

S. No.	Type of Work	Maximum laboratory dry unit weight when tested as per IS:2720 (Part 8)
1	Sub-grade	Not less than 17.5 kN./cum

Note: (1) This Table is not applicable for lightweight fill material e.g. cinder, fly ash, etc.

(2) The Engineer may relax these requirements at his discretion taking into account the availability of materials for construction and other relevant factors.

(3) The material to be used in sub-grade should also satisfy design CBR at the dry unit weight applicable as per Table No. 1.

20.3.1.1.1 General Requirements

The materials for embankment shall be obtained from approved sources with preference given to materials becoming available from nearby roadway excavation or any other excavation under the same Contract.

The work shall be so planned and executed that the best available materials are saved for the sub-grade.

Borrow Materials: Where the materials are to be obtained from designated borrow areas, the location, size and shape of these areas shall be as indicated by the Engineer and the same shall not be opened without his written permission. Where specific borrow areas are not designated by the Employer/the Engineer, arrangement for locating the source of supply of material for sub-grade as well as compliance to environmental requirements in respect of excavation and borrow areas as stipulated from time to time by the Ministry of Environment and Forests, Government of India and the local bodies, as applicable shall be the sole responsibility of the Contractor.

Borrow pits along the road shall be discouraged. If permitted by the Engineer, these shall not be dug continuously. Ridges of not less than 8.00m width should be left at intervals not exceeding 300m. Small drains shall be cut through the ridges to facilitate drainage. The depth of the pits shall be so regulated that their bottom does not cut an imaginary line having a slope of 1 vertical to 4 horizontal projected from the edge of the final section of the bank, the maximum depth in any case being limited to 1.50m. Also, no pit shall be dug within the offset width from the toe of the embankment required as per the consideration of stability with a minimum width of 10m.

Haulage of material of fill shall proceed only when sufficient spreading and compaction plant is operating at the place of deposition.

No excavated acceptable material other than surplus to requirements of the Contract shall be removed from the site. Should the Contractor be permitted to remove acceptable material from the site to suit his operational procedure, then he shall make good any consequent deficit of material arising therefrom.

Where the excavation reveals a combination of acceptable and unacceptable materials, the Contractor shall, unless otherwise agreed by the Engineer, carry out the excavation in such a manner that the acceptable materials are excavated separately for use in the permanent works without contamination by the unacceptable materials. The acceptable materials shall be stockpiled separately.

The Contractor shall ensure that he does not adversely affect the stability of excavation or fills by the methods of stockpiling materials, use of plants or siting of temporary buildings or structures.

The Contractor shall obtain representative samples from each of the identified borrow areas and have these tested at the site laboratory following a testing programmed approved by the Engineer. It shall be ensured that the sub-grade material when compacted to the density requirements as in Table 2 shall yield the design CBR value of the sub-grade.

The Contractor shall at least 7 working days before commencement of compaction submit the following to the Engineer for approval:

- (i) The values of maximum dry density and optimum moisture content obtained in accordance with IS:2720 (Part 7) or (Part 8), as the case may be, appropriate for each of the fill materials he intends to use.
- (ii) A graph of density plotted against moisture content from which each of the values in (i) above of maximum dry density and optimum moisture content were determined.
- (iii) The Dry density-moisture content-CBR relationships for light, intermediate and heavy compactive efforts (light corresponding to IS: 2720 (Part 7), heavy corresponding to IS: 2720 [Part 8] and intermediate in-between the two) for each of the fill materials he intends to use in the sub-grade. Once the above information has been approved by the Engineer, it shall form the basis for compaction.

Materials finer than 425 micron shall have Plasticity Index (PI) not exceeding 6.

The final gradation approved within these limits shall be well graded from coarse to fine and shall not vary from the low limit on one sieve to the high limit on the adjacent sieve or vice versa.

20.3.1.2 Bedding sand course:

The bedding sand shall consist of clean well graded sand passing through 4.75mm sieve and suitable for concrete. The bedding should be from either a single source or blended to achieve the grading limits as shown in Table 2.

Table-2 Gradation for Sand Bedding

Sieve size	% passing
9.5 mm	100
4.75 mm	95-100
2.36 mm	80-100
1.18 mm	60-100
600 microns	25-60
300 microns	10-30
150 microns	5-15
75 microns	0-10

- (1) Contractor shall be responsible to ensure that single-sized, gap-graded sands or sands containing an excessive amount of fines or plastic fines are not used. The sand particles should preferably be sharp (not rounded) as sharp sand possess higher strength and resist the migration of sand from under the block to less frequency areas even though sharp sands are relatively more difficult to compact than rounded sands, the use of sharp sands is preferred for the more heavily trafficked driveways. The sand used for bedding shall be free of any deleterious soluble salts or other contaminants likely to cause efflorescence. The sand shall be of uniform moisture content and within 4 % - 8 % when spread and shall be protected against rain when stock piled prior to spreading.
- (2) Saturated sand shall not be used. The bedding sand shall be spread loose in a uniform layer as per drawing. The compacted uniform thickness shall be of 45mm and within +/- 5 mm. Thickness variation shall not be used to correct irregularities in the base course surface. The spread sand shall be carefully maintained in a loose dry condition and protected against pre-compaction both prior to and following screening. Any pre-compacted sand or screeded sand left overnight shall be loosened before further laying of paving blocks take place.
- (3) Sand shall be slightly screeded in a loose condition to the predetermined depth only slightly ahead of the laying of paving unit.

- (4) Any depressions in the screeded sand exceeding 5 mm shall be loosened, raked and rescreeded before laying of paving blocks.

20.4 SAMPLING AND TESTING PROCEDURES FOR PAVER BLOCKS

20.4.1 Sample size

- Internal – Average of minimum 3 samples per 5000 blocks – for paver block manufacturers.
- Internal – Minimum 9 blocks per 5000 blocks. Average of minimum 9 blocks per site or captioned contractors.

20.4.2 Water Absorption:

Testing for water absorption shall be in accordance with IS: 2185: 1979: Part-(Specifications for Concrete Masonry Blocks) Appendix C.

20.4.3 Sampling of Paver Blocks

20.4.3.1 Method of sampling:

Before laying paver blocks, each designated section comprising not more than 50,000 blocks shall be divided into ten approximately equal groups. Nine blocks shall be drawn from each group.

20.4.3.2 Marking and Identification:

All samples shall be clearly marked at the time of sampling in such a way that the designated section of part thereof and the consignment represented by the sample are clearly defined.

The sample shall be dispatched to the approved test laboratory taking precaution to avoid damage to the paving in transit. Protect the paving from damage and contamination until they have been tested. The samples shall be stored in water at 20 °C + 5 °C for 24 hours prior to testing.

Procedure for testing of compressive strength for paver blocks shall be as per relevant BIS.

20.5 VITRIFIED TILES:

Heavy duty vitrified unpolished porcelain floor tiles for exterior use shall be of 1st quality. Heavy duty vitrified tiles shall be acid and alkali resistant, weather proof, anti skid and abrasion resistant as per International Standard for ceramic tiles ISO :13006 and EN 176 requirement. These tiles shall comply with the following requirements:

20.5.1 MATERIAL CHARACTERISTICS/ PHYSICAL/CHEMICAL PROPERTY

CHARACTERISTIC			
DIMENSION & SURFACE QUALITY	INTERNATIONAL SPECIFICATIONS ISO 13006/EN 176 GROUP B1b , IS 15622 : 2006	VALUE REQUIRED	METHOD OF TESTING
DEVIATION IN LENGTH & WIDTH	± 0.5 %	± 0.3 %	ISO-10545-2
DEVIATION IN THICKNESS	± 5.0 %	± 4.0 %	ISO-10545-2
STRAIGHTNESS OF SLIDES	± 0.5 %	± 0.2 %	ISO-10545-2
RECTANGULARITY	± 0.6 %	± 0.2 %	ISO-10545-2
SURFACE FLATNESS	± 0.5 %	± 0.2 %	ISO-10545-2
	± 0.5 %	± 0.3 %	ISO-10545-2
PHYSICAL AND THERMAL PROPERTIES			

CHARACTERISTIC			
DIMENSION & SURFACE QUALITY	INTERNATIONAL SPECIFICATIONS ISO 13006/EN 176 GROUP B1b , IS 15622 : 2006	VALUE REQUIRED	METHOD OF TESTING
WATER ABSORPTION	≤0.5%	≤0.5%	ISO-10545-3
BULK DENSITY	>2.0 GM/CC	>2.2 GM/CC	DIN 5108
FLEXURAL STRENGTH / MODULUS OF REPTURE	MIN. 35 N/MM ²	MIN. 40 N/MM ²	ISO-10545-4
BREAKING RESISTANCE	MIN. 1300 N	MIN.2600 N	ISO-10545-4
MOH'S HARDNESS	MIN. 6	7	EN-101
SURFACE ABRASION RESISTANCE	AS PER MANUFACTURE	GROUP V	ISO-10545-7
FROST RESISTANCE	NO DAMAGE	NO DAMAGE	ISO-10545-12
THERMAL SHOCK RESISTANCE	NO DAMAGE	NO DAMAGE	ISO-10545-9
MOISTURE EXPANSION	NIL	NIL	ISO-10545-10
CRAZING RESISTANCE	AS PER MANUFACTURER	RESISTANCE	ISO-10545-11
CHEMICAL PROPERTIES			
CHEMICAL RESISTANCE	NO DAMAGE	NO DAMAGE	ISO-10545-13
STAINING RESISTANCE	RESISTANCE	RESISTANCE	ISO-10545-14
COLOUR RESISTANCE	NO DAMAGE	RESISTANCE	DIN 51094

20.5.2 Preparation of Surface and Laying

Base concrete or the RCC slab on which the tiles are to be laid shall be cleaned, wetted and mopped. The bedding for the tile shall be with cement mortar 1:4 (1 cement: 4 coarse sand) or as specified. The average thickness of the bedding shall be 20 mm or as specified while the thickness under any portion of the tiles shall not be less than 10 mm. Mortar shall be spread, tamped and corrected to proper levels and allowed to harden sufficiently to offer a fairly rigid cushion for the tiles to be set and to enable the mason to place wooden plank across and squat on it. Over this mortar bedding neat grey cement slurry of honey like consistency shall be spread at the rate of 3.3 kg of cement per square metre over an area upto one square metre. Tiles shall be soaked in water washed clean and shall be fixed in this grout one after another, each tile gently being tapped with a wooden mallet till it is properly bedded and in level with the adjoining tiles. The joints shall be kept as thin as possible and in straight lines or to suit the required pattern. The surface of the flooring during laying shall be frequently checked with a straight edge about 2 m long, so as to obtain a true surface with the required slope. After tiles have been laid surplus cement slurry shall be cleaned off.

20.5.3 Pointing and Finishing

The joints shall be cleaned off the grey cement slurry with wire/coir brush or trowel to a depth of 2 mm to 3 mm and all dust and loose mortar removed. Joints shall then be flush pointed with white cement added with pigment if required to match the colour of tiles. Where spacer lug tiles are provided, the half the depth of joint shall be filled with polysulphide or as specified on top with under filling with cement grout without the lugs remaining exposed. The floor shall then be kept wet for 7 days. After curing, the surface shall be washed and finished clean. The finished floor shall not sound hollow when tapped with a wooden mallet.

20.5.4 Measurements

Length and breadth shall be measured correct to a cm before laying skirting, dado or wall plaster and the area calculated in square metre correct to two places of decimal. Where coves are used at the junctions, the length and breadth shall be measured between the lower edges of the coves.

No deduction shall be made nor extra paid for voids not exceeding 0.20 square metre. Deductions for ends of dissimilar materials or other articles embedded shall not be made for areas not exceeding 0.10 square metre. Areas, where glazed tiles or different types of decorative tiles are used will be measured separately.

20.6 TACTILE FLOORING

Tactiles (also called truncated domes, detectable warnings, tactile ground surface indicators, detectable warning surfaces) are unique non-fade, non-slip ground surface indicators. These indicators combined with other environmental information, assist visually challenged people with their orientation.

20.6.1 MATERIAL CHARACTERISTICS/ PHYSICAL/CHEMICAL PROPERTY

S.No.	TEST DISCRIPTION	IS 4457: 2007	HI-TRAFFIC	REQUIRED
A. Dimension quality				
1	Length & Width	±0.75%	±0.2%	±0.6%
2	Thickness	±5%	±5%	±5%
3	Straightness of sides	±0.5%	±0.2%	±0.4%
4	Rectangularity	±0.6%	±0.3%	±0.5%
5	Surface flatness	±0.5%	±0.3%	±0.3%
B. Physical Properties				
1	Water absorption	< 0.5%	< 0.5%	< 0.5%
2	Mohs Hardness		> 7	> 7
3	Flexural Strength (Average MOR)	>35N/mm ²	>35N/mm ²	>35N/mm ²
4	Breaking Strength	≥1300N	>1700N	>1700N
5	Abrasion resistance/Deep abrasion	>175mm ³	>144mm ³	>144mm ³
6	Abrasion resistance/Deep abrasion	>0.4	>0.6	>0.6
7	Density (gm/cc)	≥ 2	>2.2	>2.2
8	Moisture expansion	Nil	Nil	Nil
C. Chemical Properties				
1	Resistance to Conc Acid (wt Loss)	<1.5%	≥ 1%	≥ 1%
2	Resistance to household chemicals & swimming pool salts	Resistance	Resistance	Resistance
3	Stain resistance	Resistance	Resistance	Resistance
D. Thermal Properties				
1	Thermal expansion	<9X10 ⁻⁶ K ⁻¹	<9X10 ⁻⁶ K ⁻¹	<9X10 ⁻⁶ K ⁻¹
2	Thermal shock resistance	No Damage	No Damage	No Damage

20.6.2 Preparation of Surface and Laying

Base concrete or the RCC slab on which the tiles are to be laid shall be cleaned, wetted and mopped. The bedding for the tile shall be with cement mortar 1:4 (1 cement : 4 coarse sand) or as specified. The average thickness of the bedding shall be 20 mm or as specified while the thickness under any portion of the tiles shall not be less than 10 mm.

Mortar shall be spread, tamped and corrected to proper levels and allowed to harden sufficiently to offer a fairly rigid cushion for the tiles to be set and to enable the mason to place wooden plank across and squat on it. Over this mortar bedding neat grey cement slurry of honey like consistency shall be spread at the rate of 3.3 kg of cement per square metre over an area upto one square metre. Tiles shall be soaked in water washed clean and shall be fixed in this grout one after another, each tile gently being tapped with a wooden mallet till it is properly bedded and in level with the adjoining tiles. The joints shall be kept as thin as possible and in straight lines or to suit the required pattern.

The surface of the flooring during laying shall be frequently checked with a straight edge about 2 m long, so as to obtain a true surface with the required slope. Where full size tiles cannot be fixed these shall be cut (sawn) to the required size, and their edge rubbed smooth to ensure straight and true joints. Tiles which are fixed in the floor adjoining the wall shall enter not less than 10 mm under the plaster, skirting or dado. After tiles have been laid surplus cement slurry shall be cleaned off.

20.7 SAUCER DRAIN

Saucer drains are provided a means to collect water overflows or storm water in pedestrian areas. Saucer Drains are provided with holes to allow the collected water to be discharged into another drainage system. Both solid and perforated Drain pieces shall be used to collect water from pedestrian areas. They shall be manufactured by M-30 grade of concrete by vibro compaction process using joint less FRP moulds so as to achieve shuttering finish. Perforated saucer drains shall be reinforced. Saucer Drains shall be of size 300 x300. The outer Thickness shall be 100mm whereas the centre thickness shall be 75mm.

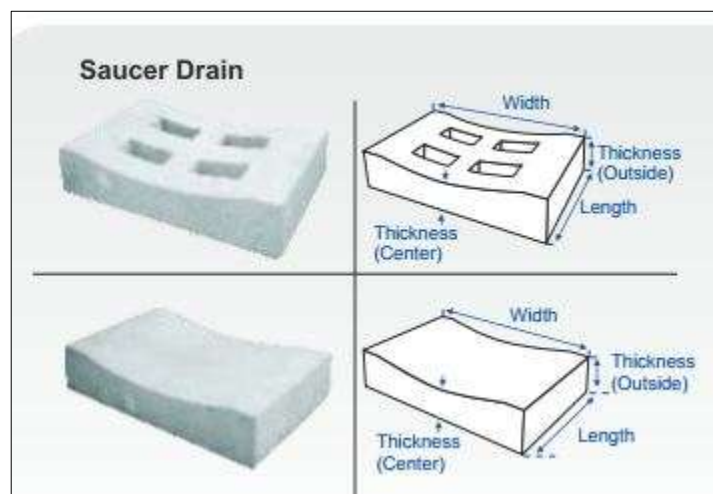

20.8 DRY STONE CLADDING

20.8.1 MATERIAL

Stone shall be of the type as specified in the item. It shall be hard, sound durable and tough free from cracks, decay and weathering and defects like cavities cracks, flaws, holes, veins, patches of soft or loose materials etc. Thickness of stone shall be as specified in the BOQ/drawings.

Stone shall be cut with the gang saw to the required size and shape on all beds and joints so as to free from any waviness and to give truly vertical horizontal surface as required. The exposed face and sides of stones forming joints shall be such that the straight edge laid along the face of the stone is in contact with every point on it. All the visible angle and edges shall be square and free from chipping. The Dressed stone shall be of the thickness specified with permissible tolerance of + 2 mm.

Before starting the work, the contractor shall get the samples of stone approved by Engineer-Incharge.

Approved sample shall be kept in custody of Engineer-in-Charge and stones supplied and used on the work shall conform to sample with regard to soundness, colour, veining and general texture. The stone shall be cut by gang saw into slabs of required thickness along the places parallel to the natural bed. When necessary double scaffolding for fixing the stone at greater heights, jib crane or other mechanical appliances shall be used to hoist the heavy pieces of stone and placed them into correct positions. Care

shall have to be taken that corners of the stone are not damaged. Stone shall be covered with gunny bags before tying chain or rope is passed over and it shall be handled carefully. No pieces which has been damaged shall be used that work

20.8.2 STACKING AND SHORING

Stone slabs are thin and brittle and should never be stacked flat across timber supports. They should therefore, be stacked on edge on timber or like runners. Packing pieces inserted between the slabs may be rope or timber. Slabs shall be well covered with plastic sheeting to protect them from any possible staining.

20.8.3 SCAFFHOLDING

Double scaffolding having two sets of vertical supports shall be provided. The supports shall be sound and strong, tied together with horizontal pieces over which scaffolding planks shall be fixed.

20.8.4 FIXING

The size & shape of the cramps shall be as per drawing and as per directions of Engineer-in-charge. The samples of steel cramps should be approved in advance before starting the stone cladding work. The cramp shall be attached to top and bottom of the stone. The cramps shall have inbuilt adjustment for vertical and horizontal alignment. The cramps used to hold support and transfer the load of stone unit to the supporting structured steel shall be designed by the manufacturer and approval of the same shall be obtained from the Engineer-in-Charge.

The minimum number of clamps required shall be as per requirement of design to carry the load of individual stone slabs. The cramps shall be spaced not more than 60 cm horizontally and vertically along the stone side for insertion of pins / bolt attached with the steel cramps. Adequate cutting in stone shall be made with precision instrument to hold the cramps pins at the joints. Stone shall be secured with clamps with high quality workmanship. The walls shall be carried up truly plumb. All the courses shall be laid truly horizontal and all the vertical joints truly vertical. The sequence of execution for cladding work shall be approved by the Engineer-in-Charge.

a. **Jointing:** Joints horizontal and vertical shall be filled with weather sealant of make as approved by Engineer-in-charge with the help of pouring gun for filling the sealant. Before filling the joint with sealant, Masking tape are required to be fixed on stones surface on both edges of joints of the stones, so that sealant may not spoil the surface of the stone. When all the joints are filled and sealant has dried, the masking tape may be removed.

b.Protection: Work shall be protected from rain by suitable covering. The work shall also be suitably protected from damage and rain during construction.

Measurement: The length and breadth shall be measured correct to a cm. The area shall be calculated in square metre correct to two places of decimal. Any opening of area 0.01 sqm. or less shall not be deducted.

b. **Rate:** The rate includes the cost of materials and labour involved in all operations described above including cost of support scaffolding staging, sealant, pouring guns but excluding the cost of steel cramps drilling holes / making recesses in stones which shall be paid for separately.

20.9 MILD STEEL WORK

20.9.1.1 General

The contractor shall submit 6 copies of shop drawings shall show all dimension, details of construction, installation relating tot eh adjoining work.

20.9.1.2 Materials :

All structural steel shall conform to IS 2062 Grade A sections for MS work and shall be free from loose mill scales, rusts, pitting or any other defects affecting its strength and durability.

20.9.1.3 Fabrication :

The grills shall be fabricated to the design and pattern shown in the drawings. All joints shall be made in best workman like manner with slotting and welding as required to the specified

size and shape. The edge of the M.S. flats shall be suitably mitred before welding to get the

desired shape. The joints shall be filled to remove excess stay after welding screws, nuts, washers, bolts, rivets and any other miscellaneous fastenings devices shall be of steel and shall be provided by the contractor.

Manufactured M.S. Grills then be fixed in between the posts, balusters, M.S. frame work etc. to correct alignment. Any undulations, bends etc. found shall be rectified by the contractor at his own cost. The complete assembly of rill / railing so fixed shall be firm and there shall not be any lateral movements.

20.9.1.4 Samples :

Samples of grill and railings shall be submitted for approval of the Engineer-in-charge and to be got approved before taking up for mass fabrication.

20.9.1.5 Installation:

The approved grills shall be fixed in position where specified and shown in drawings including in masonry walls, teakwood frames, hand railings etc. Any damages to walls, frames etc. caused during fixing the grills shall be made good by grouting with cement mortar/packing

/repairing properly at the contractors cost.

20.9.1.6 Painting:

Painting shall be done as per the specification specified under painting.

20.9.1.7 Mode of measurement :

Actual area of M.S. grill manufactured and fixed in position shall only be measured in square metre for payment. All measurements shall be taken to two places of decimal of a metre and area shall be calculated to second place of decimals of a square metre. The rate is to include the cost of all materials, labour, transporting, fabricating, installing, Scaffolding if necessary, grouting etc. complete.

20.9.1.8 Finishing / Painting/Polishing for railing:

Hand rail shall be painted with two or more coats over one coat of primer or painted with two coats of synthetic enamel paint / flat oil paint of approved make and shade over one coat of approved primer. M.S. grills, balusters, etc. also to be painted as per specifications specified under Painting/ Polishing. Wall & concrete benches shall be painted in ready mixed exterior grade paint with primer of approved quality & colour.

20.9.1.9 Mode of measurements (hand rails) :

Hand railing shall be measured for payment in running metre. The lengths shall be measured along the top center line of the hand rail and shall be measured between ends of

balusters, newels, posts as the case may be upto two places of decimals of a metre. Rates shall

include fabrication, leaving suitable pockets, grouting the same, providing an fixing suitable teak wood plugs, fixing, all labour, materials, transport, painting/polishing, finishing and scaffolding if necessary.

20.9.1.10 COBBLE STONE PAVEMENT

The specifications consist of furnishing and setting granite cobblestone pavers on a stone dust setting bed over a gravel base course in accordance with these specifications and in close conformity with the lines and grades shown on the plans or established by the Engineer/Architect.

Cobble stones. Hand Chisled Cobblestones tampered from top towards bottom surface shall be granite, of fairly uniform shape (with hand dressed edges) and color, free from cracks and other structural imperfections or flaws which would impair its structural integrity, and of a smooth appearance. Natural color variations, characteristic of the deposit source will be permitted. Samples to be approved by Consultant before Procurement.

Dimension: 100 x 100x 75 mm. (+- 5% variation)

Color: Black

Finish: Natural Split Surface.

The subbase below the stone dust setting bed shall be fine graded and thoroughly compacted. Cobblestones shall be carefully laid on a stone dust setting bed and shall be solidly rammed in position by hand. The cobblestones shall be set with the long axis of each stone vertical to the roadway surface. The cobblestones shall be set such that each cobblestone is touching another cobblestone.

The cobblestones shall be compacted and tamped with a mechanical plate compactor or by another method approved by the consultant.

The cobblestones shall be swept with a sand/cement mixture (three parts dry sand, one part cement) and fogged with water. The pavement surface shall be vibrated with a lightweight plate compactor to insure compaction between the joints. Additional joint filler of sand/cement mixture shall be uniformly distributed as necessary to fill all of the voids.

20.9.1.11 CONCRETE BOLLARD

Rugged concrete bollards 600mm tall that cannot be vandalized or moved will be used in heavy traffic pedestrian zones and cycle tracks to minimise conflict with cars and motorbikes.

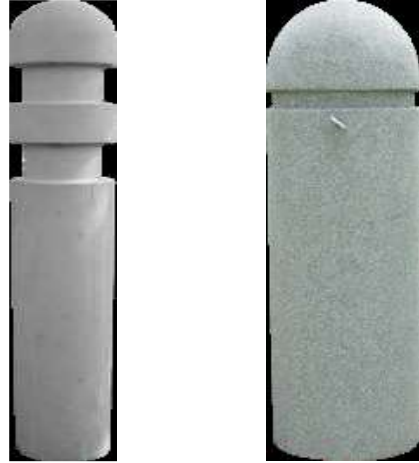

20.9.1.12 WPC (22.5MM X 138 MM X 1800 MM)

- **Composition: Wood fibre and Polythylene**

Sr. No.	Test	Test Method	Value
1	Density, Kg/m ³	IS: 1734	500 – 700
2	Water Absorption, 2 hours, %	IS: 2380	< 0.2
3	Water Absorption, 24 hours, %	IS: 2380	< 1
4	Hardness, Shore D	ASTMD 2240	>55
5	Tensile Strength, N/mm ²	IS: 1734	>11
6	Elongation at Break, %	IS: 1734	> 10
7	Modulus of Rupture, N/mm ²	IS: 1734	>20
8	Modulus of Elasticity, N/mm ²	IS: 1734	>1500
9	Screw withdrawl Strength,N	IS: 1734	>1500
10	Nail Withdrawn Strength, N	IS: 1734	>150

Wood plastic composite slats are made from sawdust and HDPE, so the product maintains a natural wood property, and is available in two textures; sanded and wood and the sizes should be as per drawings. Samples to be approved by Consultant before Procurement.

Wood-plastic composite deck boards must be installed perpendicular to the supports with two No. 10 by 2 1/2-inch-long (63.5 mm) corrosion-resistant wood screws per support. The fasteners must be placed through the solid part of the deck boards and into the supporting structure, and not through the grooved edges, at a minimum distance of 1 inch (25.4 mm) from the edge of the deck boards. Fasteners must be placed a minimum of 1 inch (25.4 mm) from the end of each board, and a minimum 1/16-inch (1.6 mm) gap must be left between ends of boards at butt joints. Multiple joists or blocking must be used to provide adequate surface for fastener embedment of board ends. Fasteners located within 1 1/2 inches (38 mm) of board ends must be predrilled. A minimum 1/16-inch (1.6 mm) gap must be left between deck boards.

Finish : Wood Grain Finish

Color: Teak

20.9.1.13 WPC (13 MM X 138 MM X 1800 MM)

- **Composition: Wood fibre and Polythylene**

Sr. No.	Test	Test Method	Value
1	Density, Kg/m ³	IS: 1734	500 – 700
2	Water Absorption, 2 hours, %	IS: 2380	< 0.2
3	Water Absorption, 24 hours, %	IS: 2380	< 1
4	Hardness, Shore D	ASTMD 2240	>55
5	Tensile Strength, N/mm ²	IS: 1734	>11
6	Elongation at Break, %	IS: 1734	> 10
7	Modulus of Rupture, N/mm ²	IS: 1734	>20
8	Modulus of Elasticity, N/mm ²	IS: 1734	>1500
9	Screw withdrawl Strength,N	IS: 1734	>1500
10	Nail Withdrawn Strength, N	IS: 1734	>150

Wood plastic composite slats are made from sawdust and HDPE, so the product maintains a natural wood property, and is available in two textures; sanded and wood and the sizes should be as per drawings. Samples to be approved by Consultant before Procurement.

The sliding clip is to be used to hold plank in place using grooves to simplify installation and create a weather resistant exterior.

Finish : Wood Grain Finish

Color: Teak

20.9.1.14 GRANITE STONE (POLISHED)

Granite stone tiles and slabs shall be pre polished (mirror polished), eggshell polished, flame finished or given any other surface treatment as specified, as per the Architectural drawings and as directed by the Engineer-in-charge.

Machine polishing and cutting to required size shall be done with water (as lubricant) only. Sawing shall also be done preferably with water as lubricant but as a special case, the Engineer-in-Charge may permit at his discretion, oil or kerosene as lubricant subject to all kerosene or oil in the body and surface of tiles / slabs being thoroughly dried in ovens. Tiles/ Slabs with stains or patches due to the use of oil or otherwise, either before or after installation, shall be rejected or shall be replaced by the Contractor at his own cost. Nothing extra shall be payable on this account. Granite stone slabs shall be individually packed in cardboard paper. These shall be handled carefully to prevent any damage. The stone slab procured shall be free of any surface defect or any edge damage. The damaged stones shall not be allowed to be used in the work. So the Contractor shall procure additional such quantities, to cover such contingencies. However nothing extra shall be payable on this account. The stone slabs shall not be waxed or touched up with dyes / colours. The granite stone slabs to be procured for the work shall match the samples shown to the Contractors before submission of the tenders. Before starting the work, the Contractor shall procure and submit the samples of granite stone for the approval of Consultant.

20.9.1.15 CNC CUTTING ON STONE & METAL SHEET

Decorative Boxes & stone Signages with CNC cutting has to be done in stone and metal sheet. Metal sheet shall be 4mm with approved CNC cut design with base in black Granite Stone cladding.

20.9.1.16 STAINLESS STEEL BOLLARD

Round Stainless Steel Bollard shall be standard class 1 reflective band with fully welded heavy steel base plated models. Stainless steel bollard shall be installed below ground into a concrete footing, core drilled for installation into a core drilled hole using epoxy adhesive or surface mounted for bolted installation. Stainless steel bollard shall be 900mm high with stainless steel grade of 316 of approximate weight of 7.4 Kg.



21.1. HORTICULTURE WORKS

21.2. General

Scope: Contractor to furnish all materials labor and related items necessary to complete the work indicated on drawing and specified herein including maintenance of the premises for 60 months after completion.

21.2.1. Materials

21.2.2. Plant materials

- (a.) Plant materials shall be well formed and shaped true to type, and free from disease, insects and defects such as knots, windburn, injuries, abrasion or disfigurement.
- (b.) All plant materials shall be healthy, sound, and vigorous, free from disease, insect pests, or their eggs, and shall have healthy, well – developed root systems.
- (c.) All plants shall be hardy under climatic conditions similar to those in the locality of the project.
- (d.) Plants supplied shall conform to the names listed on both the plan and the plant list.
- (e.) No plant material will be accepted if branches are damaged or broken.
- (f.) All material must be protected from the sun and weather until planted.
- (g.) Any nursery stock shall have been inspected and approved by the Engineer-In-Charge.
- (h.) All plants shall conform to the requirements specified in the plant list, except those plants larger than specified may be used if approved, but use of such plants shall not increase the Contract price. If the use of the larger plant is approved, the spread of roots or ball of earth shall be increased in proportion to the size of the plant.
- (i.) Deliver plants with legible identification labels.
- (j.) The minimum acceptable size of all trees after pruning, with branches in normal positions, will conform to the measurement specified in the Bill of Quantities unless stated otherwise. Calliper measurement will be taken at a point on the trunk 1.0 meter above natural ground. Plants that meet the specified measurement, but do not possess a normal configuration or balance of height and spread will be rejected
- (k.) All trees supplied will be branched as specified in the Bill of Quantities. All trees supplied must have terminal shoots.
- (l.) All specimen trees must have a minimum crown spread of not less than half the size of the overall height.
- (m.) The root system shall be conducive to successful transplantation. Where necessary, the root - ball shall be preserved by support with hessian or other suitable material. On soils where retention of a good ball is not possible, the roots should be suitably protected in some other way which should not cause any damage to roots.

21.2.3. Topsoil: (Good earth) pH range 6.5 to 7.5

- (a.) Topsoil or good earth shall be a friable loam; typical of cultivated top soils of the locality containing at least 2% of decayed organic matter (humus). It shall be taken from a well-drained arable site.
- (b.) It shall be free of subsoil, stones, earth clods, sticks, roots or other objectionable extraneous matter or debris.

(c.) It shall contain no toxic material. No topsoil shall be delivered in a muddy condition.

21.2.4. Fertilizer

- (a.) Dry farm yard manure shall be used measurement shall be in stacks, with 8% reduction for payment.
- (b.) It shall be free from extraneous matter, harmful bacteria insects or chemicals.

21.2.5. Condition

- (a.) Trees and shrubs shall be substantially free from pests and diseases, and shall be materially undamaged.
- (b.) Torn or lacerated roots shall be pruned before dispatch.
- (c.) No roots shall be subjected to adverse conditions, such as prolonged exposure to adverse conditions, such as prolonged exposure to drying winds or subjection to water-logging, between lifting and delivery.

21.2.6. Supply and substitution:

Upon submission of evidence that certain materials including plant materials are not available at time. Of contract, the contractor shall be permitted to substitute other material and plants, with an equidistant adjustment of price. All substitutions shall be subject to the approval of the Engineer-In-Charge.

21.2.7. Packaging:

Packaging shall be adequate for the protection of the plants and such as to avoid heating or drying out. Marking: Each specimen of tree and shrub, or each bundle, shall be legibly labeled with the following particulars:

Its name

The name of the supplier.

The date of dispatch from the nursery.

21.2.8. Execution

21.2.8.1. Fine Grading

- (a.) The nominated Landscape contractor will adjust with screened soil as necessary. Grades will be smooth and even on a uniform plane without abrupt changes or pockets and slope it away from the buildings.
- (b.) The nominated Landscape Contractor will verify the surface drainage of planting areas and notify the Engineer-In-Charge of any discrepancies, obstructions or other conditions considered detrimental to proper execution of the work and plant growth.
- (c.) Landscape work will be tied to the existing condition such as existing trees , palms , landscape features, utility lines , pavement curbs , etc. Finished grade will bear proper relationship to such control.
- (d.) The nominated Landscape Contractor will adjust all works as necessary to meet the conditions and fulfil the intention of the Drawings.
- (e.) After initial settlement the finish grade will be :
 - (i) Turf 20mm lower than adjacent walks, kerbs.

- (ii) Shrubs and Ground covers 40mm lower than adjacent walks, kerbs.
- (iii) Prior to planting operation, the contractor will ensure all planting areas free of weeds, debris, rocks over 25mm in diameter and clumps of earth that will not break up.

21.2.9. Tree Planting

21.2.9.1. Digging

- (a.) Trees should be supplied with adequate protection as approved. After delivery, if planting is not to be carried out immediately, balled plants should be placed cheek to cheek and the ball covered with sand to prevent drying out. Bare rooted plants can be heeled in by placing the roots in a prepared trench and covering them with earth which should be watered in to avoid air pockets round the roots.
- (b.) Digging of Pits
 - (i) Tree pits shall be dug a minimum of three weeks prior to backfilling.
 - (ii) The pits shall be 120cms in diameter and 120cms deep. While digging the pits, the topsoil upto a depth of 30cms may be kept aside, if found good (depending upon site conditions), and mixed with the rest of the soil.
 - (iii) If the soil is bad below, it shall be replaced with the soil mixture as specified further herein. If the soil is normal it shall be mixed with manure; river sand shall be added to the soil if it is heavy.
 - (iv) Flooding of Pits to reduce air pockets
 - (a.) The soil backfilled watered through and gently pressed down, a day previous to planting, to make sure that it may not further settle down after planting. The soil shall be pressed down firmly by treading it down, leaving a shallow depression all rounds for watering.
 - (b.) Planting
 - (i) No tree pits shall be dug until final tree positions have been pegged out for approval.
 - (ii) Care shall be taken that the plant sapling when planted is not buried deeper than in the Nursery, or in the pot.
 - (iii) Planting should not be carried out in water logged soil. Plant trees at the original soil depth; the soil marks on the stem is an indication of this and it should be maintained on the finished level, allowing for setting of the soil after planting.
 - (iv) All plastic and other imperishable containers should be removed before planting.
 - (v) Any broken or damaged roots should be cut back to sound growth. The bottom of the planting pit should be covered with 50mm to 75mm of soil. Bare roots should be spread evenly in the planting pit; and small mound in the centre of the pits on which the roots are placed will aid an even spread.
 - (vi) Soil should be placed around the roots, gently shaking the trees to allow soil the particles to shift into the root system to ensure close contact with all roots and to prevent air pockets.
 - (vii) Back fill soil should be firm as filling proceeds, layer by layer, care being taken to avoid damaging the roots, as follows: 25gms of 50% BHC shall be sprinkled on walls of pit, and initially pit shall be filled to 200 depth with earth mixed with 10gm of BHC. The balance earth shall be filled in a mixture of 1 : 2 (1 part manure to 2 part earth). Aldrin or equivalent shall be applied every 15 days in a mixture 0.2% which comes to 6cc in 1 litre of water.

21.2.9.2. Staking

Newly planted trees must be held firmly although not rigidly by staking to prevent a pocket forming around the stem and newly formed fibrous roots being broken by mechanical pulling as the tree rocks.

Methods: The main methods of staking shall be:

- (i) A single vertical stake, 900mm longer than the clear stem of the tree, driven 600mm to 900mm into the soil.
- (ii) Two stakes as above driven firmly on either side of the tree with cross-bar to which the stem is attached. Suitable for small bare-rooted or balled material.
- (iii) A single stake driven in at an angle 45° and leaning towards the prevailing wind, the stem just below the lowest branch being attached to the stake, Suitable for small bare-rooted or balled material.
- (iv) The end of stake should be pointed and the lower 1m to 1.2m should be coated with non-injurious wood preservative allowing at least 150mm above ground level.

21.2.9.3. Tying

Each tree should be firmly secured to the stake so as to prevent excessive movement. Abrasion must be avoided by using a buffer, rubber or hessian, between the tree and stake. The tree should be secured at a point just below its lowest branch, and also just above ground level; normally two ties should be used for tree. These should be adjusted or replaced to allow for growth.

21.2.9.4. Watering

The contractor should allow for the adequate watering in all newly planted trees and shrubs immediately after planting and he shall during the following growing season, keep the plant material well watered.

21.2.10. Fertilizing

Fertilizing shall be carried out by application in rotation of the following fertilizers, every 15 days from the beginning of the monsoon till the end of winter:

Organic well-rotted dry farmyard manure : 0.05 cum or 1 tassa

- d. Urea 25gm Or Ammonium sulphate 25gm Potassium sulphate 25gm
- e. All shrubs, which are pot grown, shall be well soaked prior to planting.
- f. Watering in and subsequent frequent watering of summer planted container-grown plants is essential.

21.2.11. Shrub Planting in Planters and Beds

All areas to be planted with shrubs shall be excavated, trenched to a depth of 600mm, refilling the excavated earth after breaking clods and mixing with manure in the ratio 8:1 (8 parts of stacked volume of earth after reduction by 20%: 1 part of stacked volume of manure after reduction by 8%).

For planting shrubs and ground cover shrubs in planters, good earth shall be mixed with manure in proportion as above and filled in planters.

Tall shrubs may need staking: which shall be provided if approved by the Engineer-In-Charge, depending upon the conditions of individual plant specimen.

Positions of shrubs to be planted should be marked out in accordance with the planting Plan.

When shrubs are set out, precautions should be taken to prevent root drying. Planting holes 60cm dia. and 60cm deep should be excavated for longer shrubs.

Polythene and other non- perishable containers should be removed and any badly damaged roots carefully pruned.

The shrubs should then be set in holes so that the soil level, after settlement, will be at the original soil mark on the stem of the shrub.

The hole should be back-filled to half its depth and firmed by treading. The remainder of the soil can then be returned and again firmed by treading.

21.2.12. Grassing

Preparation

The soil shall be ploughed and trenched (3 times) up to 45 cm depth and any hard substances including stones, old masonry, etc. shall be removed.

- i. All roots and other corms of vegetation shall be removed.
- ii. During period prior to planting the ground shall be maintained free from weeds.
- iii. Grading and final levelling of the lawn shall be completed at least three weeks prior to the actual sowing.
- iv. Regular watering shall be continued until sowing by dividing the lawn area into portions of approx. 5mts square by constructing small bunds to retain water. These “bunds” shall be levelled just prior to sowing of grass plants.
- v. At the time of actual planting of grass, it shall be ensured that the soil has completely settled.

a) Soil

The soil shall be mixed with termite control and weed control agents @ 5 kg per 1000 sqm. Also well rotten FYM (farm yard manure) @2.0 kg / sqm, bone meal @100gm / sqm, Neem Cake @100 gm / sqm. , Single Super Phosphate @ 15 gms / sqm and Copper Sulphate @ 2.5 gms / sqm shall be mixed and the soil dressed upto 1cm thickness, with soil and river silt in the ratio 1:2. The soil itself shall be ensured to the satisfaction of the Engineer-In-Charge to be a good fibrous loam, rich in humus.

b) Sowing the grass roots

Grass roots (Selection No.1 or a local genus approved by the Engineer-In-Charge) shall be obtained from a grass patch, seen and approved before hand.

- i. The grass roots stock received at site shall be manually cleared of all weeds and water sprayed over the same after keeping the stock in a place protected from sun and dry winds.
- ii. Grass stock received at site may be stored for a maximum of three days.
 - (a) In case grassing for some areas is scheduled for a later date fresh stock of grass roots shall be ordered and obtained.
 - (b) Small roots shall be dibbled about 7.5cms apart into the prepared grounds.
 - (c) Watering shall be done sparingly but regularly till new growth starts.

- (d) Grass areas will only be accepted as reaching practical completion when germination has proved satisfactory and all weeds have been removed.
- (e) Maintenance
- (f) As soon as the grass is approximately 3cm high it shall be rolled with a light wooden roller in fine, dry weather – and when it has grown to 5 to 8cms above ground, weeds must be removed and regular cutting with the scythe and rolling must be begun.
- (g) A top – dressing of farm yard manure, Bone meal @50gm / sqm and NPK @10 gm / sqm shall be applied when the grass is sufficiently secure in the ground to bear the mowing machine, the blades must be raised an inch above the normal level for the first two or three cuttings. That is to say, the grass should be cut so that it is from 4 to 5cms in length, instead of the 3cm necessary for mature grass.
- (h) Micronutrients mixture shall be sprayed after 30 days from the first growth. In the absence of rain, in the monsoon the lawn shall be watered with sprinklers every, three days soaking the soil to a depth of at least 20cms.
- (i) Damage, failure or dying back of grass due to neglect of watering especially for seeding out of normal season shall be the responsibility of the contractor. Any shrinkage below the specified levels during the contract or defects liability period shall be the rectified at the contractor's expense.
- (j) The contractor is to exercise care in the use of rotary cultivator and mowing machines to reduce to a minimum the hazards of flying stones and brickbats. All rotary mowing machines are to be fitted with safety guards.

c) Rolling

Lawn mower with roller shall be used periodically, taking care that the lawn is not too wet and sodden.

d) Edgings

These shall be kept neat and must be cut regularly with the edging shears.

e) Watering

Water shall be applied at least once in three days during dry weather. Water whenever done should be through and should wet the soil at least up to a depth of 20cms.

f) Weeding

Prior to regular mowing the contractor shall carefully remove rank and unsightly weeds.

21.4.1 COCONUT PEAT BLOCK

Supplying and stacking at site COCONUT PEAT BLOCKS (0.3X0.3X0.14 M) , including carriage up to 1 km (1 block is equivalent to 70 litres(approx.)/0.07 Cu.M/5 Kg+ /-0.3Kg) with moisture content Less than 20% , with pH value 5.2 to 6.8 .

Topiaries / Animal Maniquest

The Contractor shall be required to Supply, Prepare & Fixing of Perennial Plants by clipping the foliage and twigs of trees, shrubs to develop & maintain clearly defined shapes of spiral topiaries and animal maniquettes of animal's deer, rabbit & elephant has to be installed as specified in the Detail drawings. The topiaries shall be clipped to metal wire topiary frame of the Specified animals/ Maniquettes.



Animals Maniquette of Height -150 -190 cm

22.1 SPECIFICATION FOR STREETSCAPE

22.1. BENCH:

Seating bench with or without back rest shall be manufactured using combination of stainless steel & WPC. The stainless steel shall be of 304/316 grade matt finished as per design. Stainless Steel sheet/plates shall be of 16 gauge, round pipe shall be of 50/25 dia and 2mm thickness, square pipe shall be of size 50mmx50mm and 2mm thickness, rectangle pipe shall be of 25mmx50mm and 2mm thickness, base plate shall be 8mm thick and stainless steel fastener shall be of 10mmx100mm. WPC slats shall be as per Specification mentioned above.

Bench Size shall be as follows. The Bench shall be as per approved Design.

Length : 1200mm

Width : 450 mm

Height from Ground : 450 mm

Base plate to be fixed on ground: 400mmx120mmx8mm

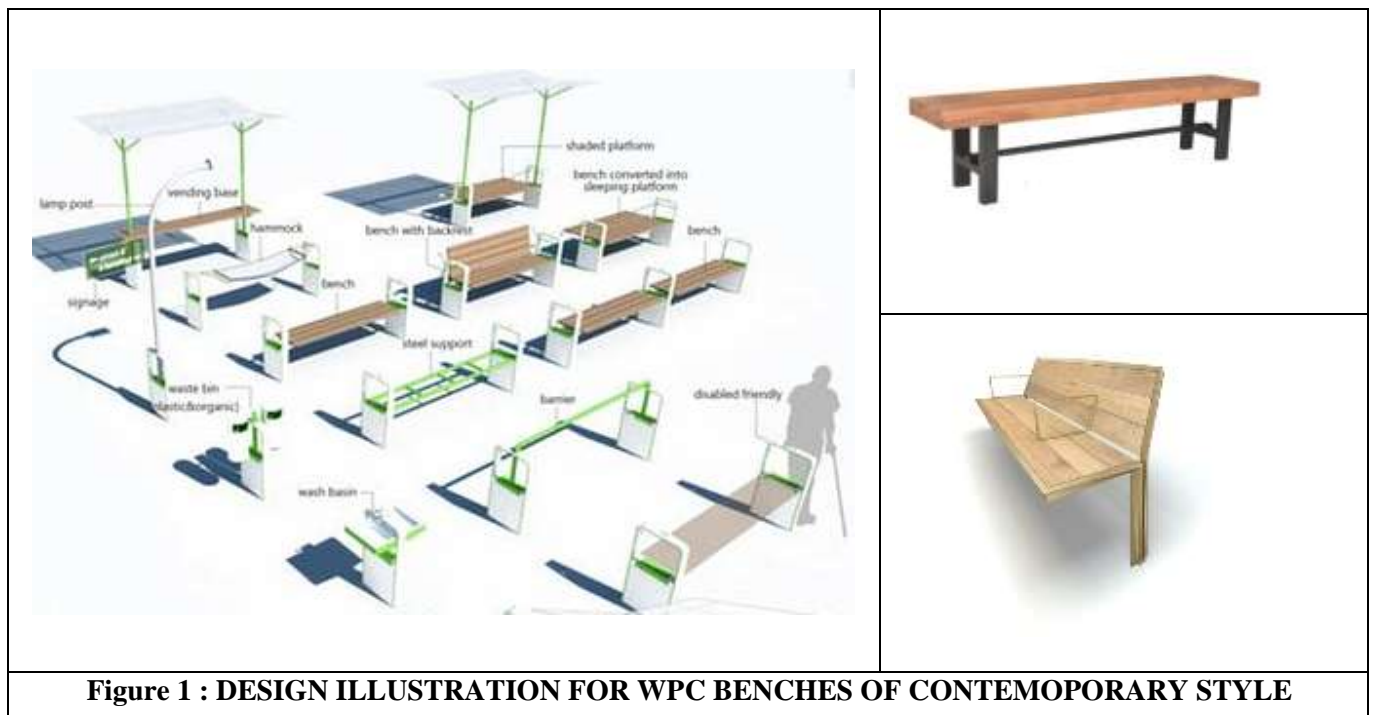

Stone bench with or without back rest shall be manufactured from 30mm thick Granite Stone Benches & 40mm thick red sandstone benches as per approved detail & design.

22.2. STONE-BENCH DETAIL:

Length: 1200mm

Width: 450mm

Height from ground: 450mm



22.3. BENCH:



SECTOR-21D ROAD

SPECIFICATION: BENCH-01

Precast Concrete Reinforced Bench. The Bench consists of grey cement color of thickness - 100mm, back light - 1000mm & front height - 450mm, base width - 620mm, manufactured by using M-40 Grade of Concrete & reinforced suitable to prevent damage during handling, transportation, erection & long use.



ROAD NO. 1

SPECIFICATION: BENCH-2

Precast Concrete Reinforced straight bench with back of size - 60"x24", front height-18" and thickness-4", Colour- red, manufactured by using M-40 Grade of Concrete & reinforced suitable to prevent damage during handling, transportation, erection & long use. All parts are joined together with galvanized nuts & bolts of suitable size.



ROAD NO. 2

SPECIFICATION: BENCH-3

Precast Concrete Reinforced straight bench without back of size - 66"x18" and weight 140 kg,Color- white , manufactured by using M-40 Grade of Concrete & reinforced suitable to prevent damage during handling,transportation, erection & long use.



SECTOR-21B ROAD

SPECIFICATION: BENCH-4

Precast Concrete Reinforced straight bench with back of size - 18"x32"x48" and weight 215 kg, Color- yellow, manufactured by using M-40 Grade of Concrete & reinforced suitable to prevent damage during handling, transportation, erection & long use. All parts are joined together with galvanized nuts & bolts of suitable size.



JIVA MARG

SPECIFICATION: BENCH-5

Precast Concrete Reinforced straight bench without back of size - 60"x18"x18", Color- wood brown with white legs, manufactured by using M-40 Grade of Concrete & reinforced suitable to prevent damage during handling, transportation, erection & long use.



NH2 SERVICE ROAD

SPECIFICATION: BENCH-6

Precast Concrete Reinforced straight bench with back of Size - 72"x16" and 18" high, Color- grey, manufactured by using M-40 Grade of Concrete & reinforced suitable to prevent damage during handling, transportation, erection & long use.

All parts are joined together with galvanized

MAIN BANDH ROAD

SPECIFICATION: BENCH-7

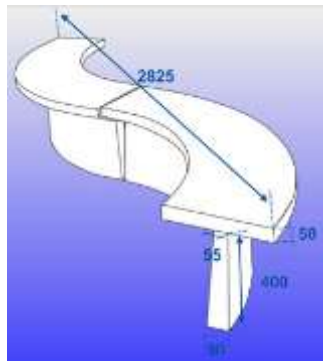

Precast Concrete Reinforced Bench- Dimensions: Sitting Platform size - 2825mm length X 400 mm width X 50mm Thickness; Leg size - 400mm Height X 400mm Width X 80/55mm thickness; Sitting height is 450 mm. Sitting Platform is in Red colour while the legs are in grey colour. Manufactured by using M-30 grade of Concrete. Suitably reinforced to promote long use and to prevent damage during handling, transportation & erection. Treated with special anti-corrosive, water proof coating so as to make the surface glossy and water proof

ITI ROAD

SPECIFICATION: BENCH-8



Precast Concrete Reinforced straight bench without back of size - 60"x18"x18" ,Color-white, manufactured by using M-40 Grade of Concrete & reinforced suitable to prevent damage during handling, transportation, erection & long use.

RAILWAY ROAD

SPECIFICATION: BENCH-9



Precast Concrete Reinforced Bench around pillars with size:1200 mm X 1000 mm X 50 mm Reinforced suitably to promote long use to (Thickness) height: 450mm.Prevent damage during handling.

Manufactured by using an M-30 grade of transportation erection long use. Bench top is treated with a special anti-corrosive waterproof coating as to make surfaces glossy or terrazzo finish.

STATION ROAD

SPECIFICATION: BENCH-10



Precast Concrete Reinforced straight bench without back of size - 66"x18", height-18", thickness-4" and weight 140 kg, Color- red ,with 3 no's of reinforced concrete planks in red color of size 66" X 6"mm X 4",manufactured by using M-40 Grade of Concrete & reinforced suitable to prevent damage during handling, transportation, erection & long use. All parts are joined together with galvanized

SHAHEED BHAGAT SINGH MARG

SPECIFICATION: BENCH-11



Precast Concrete Reinforced curved bench without back of size - 60"x18"x18" ,Color- grey, manufactured by using M-40 Grade of Concrete & reinforced suitable to prevent damage during handling ,transportation, erection & long use.

22.4. BOLLARDS

Bollards shall be installed at pedestrian crossing. The bollards are of concrete/cast iron / steel etc & shall serve the purpose of defining the edge of the road and guide pedestrians.

Concrete Bollards of M-30 grade, by vibro compaction method using FRP/steel. The Foundation slab shall be made in min. M25 concrete.



Figure 2: Concrete Bollards



Figure 3: Stone Bollard in red sandstone

The bollards shall not be fragile and safely secured to its foundation. All bollards shall be of uniform shape, size, colour on the same width of the road. Overall Dimensions: 918 mm Height X 300 mm Dia. Suitable reinforced to promote long life and to prevent damage during handling, transportation, & erection moulds, so as to achieve shuttering finish. Stone bollard shall be of red sandstone chisel dressed of height of 900mm & 150mm in width as per approved design & detail

22.5. Concrete/ Wall Bench

Concrete Bench Shall as per Approved Drawings. Sitting platform size - 1800 mm length X 450mm width X 50 mm Leg size - 400mm Height X 450mm Width X 150mm .Sitting height is 450 mm (overall) It has to accommodate 3-4 persons comfortably It shall be placed on footpath in a way that the pedestrians pass-by without disturbing the user Materials All components are manufactured using M-30 grade of Concrete using vibro compaction process. All parts shall be joined together with galvanized nuts & bolts of suitable size and all bolts are sealed after assembly.



22.6. Stone Signage

Design & detail of Stone Signages shall be as per detail Drawing. Stone Signage shall be around 1.5m high with letter/ number engraved in Stone with linear lights. The Framework for the Stone signage shall be fitted with 50 X 50 MS box section either side with linear light fittings.

22.7. TREE GRATE

The Overall dimensions 1800mm x1800mm x 40/100mm thickness .Suitably reinforced for long use and to prevent damage during transportation & handling .Manufactured with M-30 grade of concrete using vibro-compaction process using jointless FRP moulds so as to achieve shuttering finish on five faces and gurmala finish on the top surface. A choice of standard colors and unlimited custom colors will match any natural stone finish or interlock pavers in the surrounding. The top surface of the tree grates shall be polished.

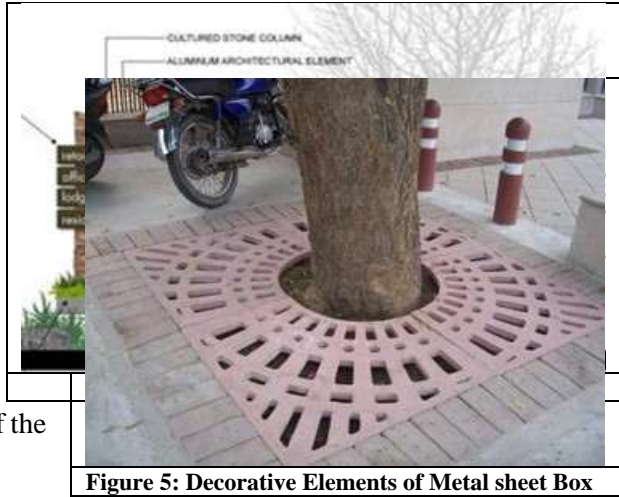

Figure 5: Decorative Elements of Metal sheet Box

23.1. LIGHTING:

Note : The Bidder should select Lighting Company based on the following pre-qualification criteria and lighting manufacturer should qualify for the below mentioned minimum qualification criteria. The contractor will submit relevant documents proof and take approval from FSCL.

The Lighting Company should be at least be there in Indian market for minimum 5 years with their LED luminaire products, PAN India presence & a manufacturing / dedicated vendor set up.

Company should not be a loss making company during the said period, copies of certificates, audit reports for last three years shall be submitted.

Lighting Company must have their own Lighting Management & Controls (LMS) System or a tie up with LMS Company which should be > 7 years old.

The Lighting Company should provide experiences of doing similar (Connected Street Lighting project) works either directly under their names or carried out by their Value Added partners. All certificates/evidences of such works should be furnished with attested copies, in case of fraud documents the lighting manufacturer will be rejected.

The offered LED luminaires must have passed LM 79, IEC 60598 from UL/ ERTL laboratory only and attested copies of the test certificates must be attached. The testing of luminaires should be meeting performance standards as per IS 16107. Certificate from UL/ERTL Laboratory conforming to the performance standards as per IS 16017 should be submitted along with the bid.

The Lighting Company shall have to submit LM 80 test certificates from the LED manufacturer for the LEDs used in the LED luminaire.

The Lighting Company should give in writing full support for testing, commissioning, maintenance of lighting system either directly or through their Value-Added Partners.

Details of the proposed luminaire shall be submitted along with in the technical specification details as requested in RFP and have it approved by FSCL.

The lighting company should have in house lighting laboratory to carry out all tests required as per Indian Standards and such laboratory should have NABL certificates. Certificate of accreditation of Laboratory of the Manufacturer - Bidder to submit the list of tests which are applicable for Intelligent Street Lighting Project and covered in NABL accreditation given to laboratory. These test should include Electrical & Electronics tests, Environmental Test & Photometric Test. If these tests are not covered in the accreditation, then report for those test for luminaire from another NABL accredited lab should be submitted.

The lighting company should have relevant organizational set up for in house lighting design and System support team to support /Value added partners to support the Bidder.

- (a) Lighting columns shall be placed so that they do not impinge on available widths of footways in the interests of wheelchair users and people pushing prams, or pose a hazard for blind or partially sighted people. Consideration shall be given to incorporating colour contrast bands on lighting columns.

- (b) Median Lighting will illuminate both sides of carriageway and while post top lights will lit up the walkway and cycle track, including any traffic-calming features, to enable road users to see potential obstacles and each other after dark.
- (c) While lighting fulfils a number of important purposes in residential areas, care should be taken not to over-light, which can contribute unnecessarily to light pollution, neighbourhood nuisance and energy consumption.

23.2. Lights Pole:

The bidder shall design the foundation, poles, luminaires, etc. for all Loadings including wind. The bidder shall submit the design to FSCL for its approval. The bidder shall modify the design and resubmit it till it is approved by the FSCL. The bidder shall submit the Mock Sample of the pole type (architecture) and have it approve by the FSCL. Only after the pole architecture is approved, the bidder may commence the design of the pole.

- (a) Designing, Supply, Install, Testing and commissioning of Single arm/ double arm light pole with LED luminaires (IP 66) with 7 nos. feeder pillars for proper distribution of power to lights along the road. Provision for dimming solution of each pole and controlled from Command Control Centre with LORA gateway. Pole should be made of GI of minimum 150 mm inner diameter and height of 7 and 9 metre with powder coating minimum thickness of 50 μ of colour as per Engineer -in-Charge. The shape of pole shall be as per below images. The LED street light luminaire shall be designed by the bidder such that it provides adequate lighting and illumination to cover footpath & cycle track. The lux level shall be 15 lux on 'cycle track and footpath' on 30 lux on carriageway. The pole shall be erected on concrete foundation designed by bidders for all Loads including wind. LED lamp, driver with luminaire shall be as per RFP.

Images for light poles for various road/ streets are as per following:

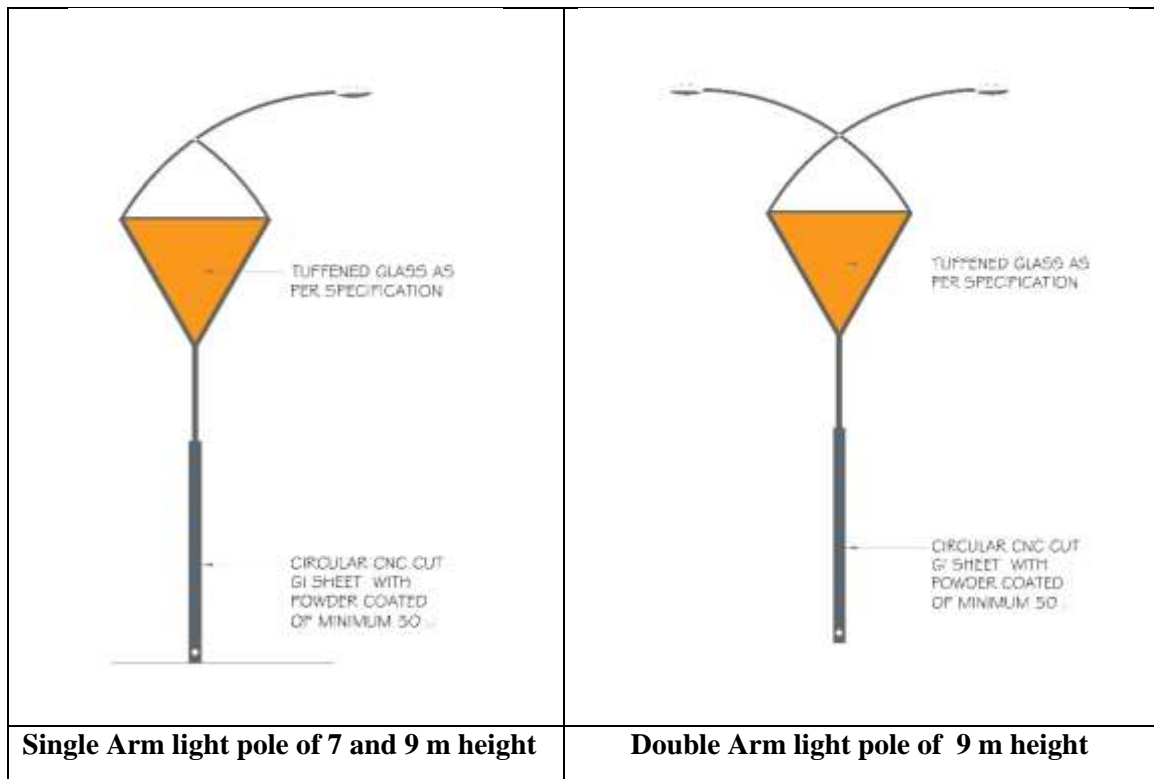

- (b) Designing, Supply, Install, Testing and commissioning of Columnar light with LED luminaire (IP 65) with 1 nos. feeder pillars for proper distribution of power to lights along the road. Pole shall be made of GI of minimum 150 mm inner diameter and height of 4.2 metre with powder coating of colour as per E-in-C, of minimum thickness of 50 μ and integrated with 90w LED. The shape of pole shall be as per the image given below.



- (c) Drive over light. Luminaire made up of die-casting dark grey powder coated aluminium, corrosion resistance with low copper content. Hard chrome plated stainless steel 316 grade front ring. Silicone seal gasket. Stainless steel screws. Step tempered glass of 7mm thickness with static load resistance of ≥ 2000 kgs. Luminaire hard wired with 3 x 1.0mm² cable of 0.5mts length. Supplied with mounting sleeve for preparing recessed opening in ground. Integral power supply. Earth connection. Safety class I. Protection class IP67 Mechanical resistance IK10. Conformity mark. Suitable for operation on 240V, 50Hz single phase ac supply. Dimension : 55 mm dia x 86 mm integrated with 3w LED and 2 way connector.



- (d) In ground luminaire with symmetrical beam angle of 20 degree. Luminaire made up of die-casting dark grey powder coated aluminium, corrosion resistance with low copper content. Hard chrome plated stainless steel 316 grade front ring. Silicone seal gasket. Stainless steel screws. Step tempered glass of 7mm thickness with static load resistance of 1704 kgs. Optical reflector efficiency $\geq 85\%$ Luminaire hard wired with 3 x 1.0mm² cable of 0.5mts length. Supplied with mounting sleeve for preparing recessed opening in ground. Integral power supply. Earth connection. Safety class. Protection class IP67. Mechanical resistance IK08. Conformity mark. Suitable for operation on 240V, 50Hz single phase ac supply. Dimension 55mm dia x 80mm integrated with 3W LED and 2 way connector. Fixture Specifications to be approved by Consultant before Procurement.



- (e) LED Linear Lighting giving homogenous light output, made of combination of special plastic material resistant to saltwater and UV radiation and 316L grade of stainless steel having robust design with vandal resistance rating of IK10 and ingress protection rating of IP67, fixture should

have wattage of 9.6W/mtr having color of LED in 3000K/4000K /Amber or as per consultant request, fixture should have dimensions width 18mm, height 35mm and length 1000mm, should have cable outlet at the back thus giving seamless, shadow-free illumination. Fixture to have high-quality LED 24VDC, With integrated driver electronics fixture to have service life > 50,000 h. Fixture's temperature range from - 25°C to + 50°C. Fixture's mounting clamp made of stainless steel 316L grade for mounting. Should be CE certified.



- (f) Providing and fixing of In ground luminaire with asymmetrical beam angle of 35 degree. Luminaire made up of die-casting grey powder coated aluminium, corrosion resistance with low copper content. Hard chrome plated stainless steel 316 grade front ring. Molding shaped seal gasket. Stainless steel screws. Step tempered glass of 10mm thickness with static load resistance. Optical reflector efficiency \cong 90% Luminaire hard wired with 3 x 1.0mm² cable of 0.5mts length. Supplied with mounting sleeve for preparing recessed opening in ground. Integral power supply. Earth connection. Safety class I. Protection class IP67. Mechanical resistance IK09 & IK10. Conformity mark. Suitable for operation on 240V, 50Hz single phase ac supply. Dimension : 173 mm dia x 128mm integrated with 14 w LED.



24.1. TECHNICAL SPECIFICATION OF ELECTRICAL ITEMS

TECHNICAL SPECIFICATION FOR PCC POLES (11 METER LONG)

24.2 SCOPE:

This specification covers manufactures assembly testing at manufacturer works of PCC poles with an overall length of 11.00 M and working load of 400 kg at 0.6 M from the top (As per drawings attached) suitable for use in over head 33 kV & 11 kV lines as per schedule of requirement.

24.3 APPLICABLE STANDARDS:

Except when they conflict with specific requirement in the specification the poles shall comply with the relevant provisions made in the following Indian standards specification with the latest version thereof.

- a) IS: 1678-1979 Specification for prestressed concrete poles for overhead power telecommunication lines.
- b) IS: 2905-1966 Methods of test for concrete pole for overhead power, traction telecommunication lines.
- c) IS: 7321-1974 code of practice for selection, handling and erection of concrete poles for overhead power and telecommunication lines.
- d) IS: 1343-1980 code of practice for pre-stressed concrete.
- e) IS: 456-1978 code of practice for plain & reinforced concrete.
- f) IS: 1785 (Latest edition) for H.T. steel wires for pre-stressed concrete

24.4 CLIMATIC CONDITIONS:

The equipment/material to be supplied against this specification shall be suitable for satisfactory operation under the following climatic Conditions.

Sr. No.	Location	At various locations in the state of Haryana
1	Maximum ambient temperature (°C)	60
2	Minimum ambient air temperature (°C)	-5
3	Maximum average daily ambient temperature (°C)	40
4	Maximum yearly weighed average ambient temperature (°C)	32
5	Maximum altitude above mean sea level	1000
6	Minimum Relative Humidity (%)	26
7	Maximum Relative Humidity (%)	95
8	Average no of Rainy days/ year	120
9	Average annual rainfall	900 mm
10	Maximum wind pressure	195 kg/m sq.

The equipment shall be for use in moderately hot and humid tropical climate conducive to rust and fungus growth.

24.5 Terminology: For the purpose of this standard, the following definitions shall apply:

24.6 Average permanent load: That fraction of the working load which may be considered of long duration over a period of one year.

24.7 Load factor: The ratio of ultimate transverse load to the transverse load at first crack.

24.8 Transverse: The direction of the line bisecting the angle contained by the conductor at the pole. In the case of straight run, this will be normal to the run of the line.

24.9 Transverse load at first crack: For design, the transverse load at first crack shall be taken as not less than the value of the working load.

24.10 Working load: The maximum load in the transverse direction, that is ever likely to occur, including the wind pressure on the pole. This load is assumed to act at a point 600 mm below the top with the butt end of the pole planted to the required depth, as intended in the design.

24.11 Ultimate failure:

The conditions existing when the pole ceases to sustain a load increment owing to either crush of concrete, or snapping of the prestressing tendon or permanent stretching of the steel in any part of the pole.

24.12 Ultimate transverse load:

The load at which failure occurs, when it is applied at a point 600 mm below the top and perpendicular to the axis of the pole along with the transverse direction with the butt end of the pole planted to the required depth as intended in the design.

24.13 Materials:

a. Cement:

The cement used in the manufacture of prestressed concrete poles shall be ordinary or rapid hardening Portland cement conforming IS: 269 -1989 (specification of ordinary Portland cement) & IS: 8041-1990 (specification for rapid hardening Portland cement).

b. Aggregates:

Aggregates used for the manufacture of pre-stressed concrete poles shall conform to IS: 383-1970 (Specification for coarse and fine aggregates from natural sources for concrete). The nominal max. Size of aggregates shall in no case exceed 10 mm.

c. Water:

Water should be free from chlorides, sulphate other salts and organic matter portable water shall be generally suitable.

d. Admixtures:

Admixtures should not contain calcium chloride or other chlorides and salts which are likely to cause corrosion of pre-stressing steel.

e. Pre-stressing Steel:

The pre-stressing steel wires, including those used as untempered wires should conform to IS :1785 (part-1)- 1967 (specification for plain hard drawn steel wire for pre-stressed concrete part-1 cold drawn stress relieved wire), IS :1785 (part-11) -1967 (specification for plain hard drawn steel wire for prestressed

concrete part-11 as drawn wire) , or IS :6003-1970 (specification for intended wire for prestressed concrete)or the latest version thereof .

f. Concrete

The concrete Mix shall be designed to the requirement laid down for controlled concrete (also called design mix. Concrete) in IS :1343-1980(code of practice for plain & reinforced concrete) subject to the following special conditions

a) Minimum works cube strength at 28 days should be at least 400kg/cm²

b) The concrete strength at transfer should be at least 200kg/cm²

c) The mix. Should contain at least 380kg of cement per cubic meter of concrete

d) The Mix should contain as low water content as is consistent with adequate workability, if it become necessary to add water to increase the workability. If it becomes necessary to add water to increase the workability, the cement content also should be raised in such a way that the original value of water cement ratio is maintained.

24.14 WELDING AND LAPPING OF STEEL:

The high tensile steel wire shall be continuous over the entire length and the tendon welding shall not be allowed in any case. However, jointing or coupling be permitting provided the strength of the joint or coupling is not less than the strength of each individual wire.

24.15 MANUFACTURE:

All prestressing wires and re-enforcements shall be accurately fixed as shown in the drawings and maintained in position during manufacture. The unmentioned re- informants, as indicated in the drawing , should be held in position by use of stirrups which should go round all the wires.

All wires shall be accurately stretched with uniform prestress in each wire. Each wire or group of wires shall be anchored positively during casting care shall be taken to see that the anchorages do not yield before the concrete attains necessary strength.

24.16 Covers: The cover concrete measured from the outside of the prestressing tendon shall be normally 22mm.

24.17 Compacting: Concrete shall be compacted by spinning, vibrating, shocking or other suitable mechanical means. Hand compaction shall not be permitted.

24.18 Curing:

The concrete shall be covered with a layer of socking canvas, Hessian or similar absorbent material and kept constantly wet up to the time when the strength of concrete is at least equal to the minimum strength of concrete at transfer of prestress. Thereafter, the pole may be removed from the mould and watered at intervals to prevent surface cracking of the unit, the interval should depend on the atmospheric humidity and temperature.

The prestressing wires shall be detensioned only when the concrete has attained the specified strength at transfer (i.e. 200kg/cm²). The cubes cast for the purpose of determining the strength at transfer should be cured, as far as possible, under conditions similar to those under which the poles are cured. The transfer stage shall be determined based on the daily tests carried out on concrete cubes till the specified daily tests carried out on concrete cubes till the concrete strength indicated above is reached. Thereafter, the test on concrete shall be carried out as detailed in IS-1343-1980(code of practice for prestressed concrete) The

manufacturer shall supply, when required by the purchaser or his representative, results of compressive test conducted in accordance with IS:456-1978 (code of practice for plain and reinforced concrete) on concrete cubes made from the concrete used for the poles. If the purchaser so desire manufacturer shall supply cubes for test purposes & such cubes shall be tested in accordance with IS :456-1978 (code of practice for plain & reinforced concrete) The detensioning shall be done by slowly releasing the wires, without imparting shock or sudden load to the poles. The rate of detensioning may be controlled by any suitable means either mechanical (screw type) or hydraulic. The poles shall not be detensioned or released by cutting the pre-stressing wires using flames or bar coppers while the wires are still under tension.

24.19 Earthing:

Earthing shall be provided by having a length of 8 SWG GI wire embedded in concrete during manufacture and the ends of the wires left projecting from the pole to a length of 175mm at 250mm from top and 450mm below ground level.

The earth wire shall not be allowed to come in contact with the prestressing wires.

24.20 Handling:

Separate eye hooks shall be provided for handling and transport one each at a distance of 165cms from either end of pole and they should be on the face that has the shorter dimension of the cross section.

24.21 TESTS

24.21.1 Transverse strength Tests:

- (i) Pole made from ordinary Portland cement shall be tested only on the completion of 28 days and poles made from rapid hardening cement only on the completion of 14 days after the date of manufacture.
- (ii) The pole may be tested in either horizontal or vertical position. If tested in horizontal position, provisions shall be made to compensate for the overhanging weight of the pole, for this purpose the overhanging portion of the pole may be supported on a movable trolley or similar device.
- (iii) The pole shall be rigidly supported at the butt and for a distance equal to the agreed depth of planting i.e. 1.80 M.
- (iv) Load shall be applied at a point 600mm from the toe of the pole and shall be steadily and gradually increased to the design value of the transfer load at first crack. The deflection at this load shall be measured.
- (v) A prestressed concrete pole shall be deemed not to have passed the test if visible cracks appear at a stage prior to the application of the design transfer load for the first crack.
- (vi) The load shall then be reduced to zero and increased gradually to a load equal to the first crack load plus 10% of the minimum ultimate transverse load, and held up for 2 minutes. This procedure shall be repeated until the load reaches the value of 80 percent of the minimum ultimate transverse load and thereafter increased by 5 percent of the minimum ultimate transverse load until failure occurs. Each time the load is applied, it shall be held for 2 minutes. The load applied to prestressed concrete pole at the point of failure shall be measured to the nearest five kilograms.
- (vii) Concrete pole shall be deemed not to have passed the test if the observed ultimate transverse load is less than the design ultimate transverse load.
- (viii) Measurement of cover: After completion of the transverse strength test, the sample pole shall be taken and checked for cover. The cover of the pole shall be measured at 3 points, one within 1.8 meter from the butt end of the pole, the second within 0.6meter from the top and the third at an intermediate point and the mean value compared with the specified value.

The mean value of the measured cover should not differ by more than the ± 1 mm from the specified cover. The individual values should not differ by more than ± 3 mm from the specified value.

If these requirements are not met the workmanship with reference to aligning of the end plates and pre-stressing and assembly of moulds should be improved and inspection at production stage tightened suitably.

24.22 INSPECTION:

Inspection of material and supervision of tests in accordance with the relevant Indian standards mentioned in clause-2 above and supporting drawing and schedules and approved manufacture specification shall be carried out by the purchaser or duly authorized representative. The material shall be inspected and tested before dispatch by an authorized representative of the Nigam in respect of quality. The manufacturer shall provide to the inspecting officer all reasonable facilities without charge to satisfy him that the material is being furnished in accordance with the specifications/drawings.

The purchaser has the right to have tests carried -out at the cost of supplier by and independent Govt. agency where'; ever there is dispute regarding the quality of material supplied .

24.23 STACKING

The supplies shall stack the poles in such a way that it is possible for the inspecting officer to select and inspect the poles, as he may choose to inspect. All such facilities for taking out the selected poles will be extended by the supplier free of charge.

24.24 MARKING:

The poles shall be clearly engraved with the following particulars during manufacturing, so as to be easily readable after erection in position:

1. Date, Month & year of manufacture.
2. Transverse Strength of pole in Kg.
3. Maker's serial no. and mark.
4. "DHBVN" (Distinct name of the distribution utility)
 - i) PO No. & Date and Nigam sr no. be clearly marked with indelible ink.
 - ii) Planting depth will be embossed on each pole.

Schedule Of Guaranteed And Other Technical Particulars For Pcc Poles (To Be Submitted By The Tenderer).		
SNo.		
1	Over length of pole	m
2	Working load at 0.6 Meters from top	kg.
3	Factor of safety	
4	Bottom depth	cm
5	Top depth	cm
6	Breath	cm
7	No. of tensioned wires per pole	no.
8	No. of untensioned wires per pole	no.
9	Length of each untensioned wire	
10	Concrete quantity	m ³ /pole
11	Steel quantity	kg/pole
12	Cement quantity	kg/pole

25.1. TECHNICAL SPECIFICATION OF P.G. CLAMPS FOR 11kV OVERHEAD CONDUCTOR

25.2. SCOPE

This specification covers the manufacture, testing before despatch and delivery at our Stores/ Site of P.G. Clamps for ACSR Panther, Dog, Rabbit Conductor and T-clamp for Panther Conductor as detailed hereunder.

25.3. MATERIAL

All material used shall conform to the relevant ISS. All aluminium and aluminium alloy used in the manufacture of the connector(s) shall conform to designation 'A6' of IS: 617 (1975) Latest amended and IS:1367 (latest amended). Non ferrous alloy bolts, nuts and spring washers shall conform to the relevant Standards.

The material used in the manufacture of clamps shall be Aluminium alloy 4600 of IS:617-1994 as amended and shall be gravity die casting process only.

Steel Bolts and Nuts shall conform to IS:1368-1992 & IS:1367/1979-80 (with latest amendment, if any)

All ferrous metal parts intended for outdoor use except those made of stainless steel shall be protected by hot dip galvanizing in accordance with IS:2633-1986.

The temperature rise of power connectors above a reference ambient temperature of 40 Deg. C when carrying rated current as above shall not exceed 45 Deg. C to fulfill the requirement of Cl.6 IS:5561(1970)

25.4. GENERAL REQUIREMENTS:-

The power connectors shall be smooth and free from cavities, blow-holes and other defects and such adverse effects like sharp radii of curvature, ridges & excrescence which might lead to localized pressure or damage to conductor in service. Power connectors shall be so designed and proportioned that they are capable of safely withstanding stresses to which they may be subjected (including these due to short circuit and climatic conditions) and that the effect of vibrations, both on the conductor and the connector itself are minimized. Sufficient contact pressure should be maintained at the joint by the provision of the required number of bolts or other fixing arrangements. But the contact pressure should be evenly distributed by the use of pressure plates, washers or suitable saddles of adequate area & thickness.

25.5. CLIMATIC CONDITIONS:

The equipment/material to be supplied against this specification shall be suitable for satisfactory operation under the following climatic Conditions

Sno.	Location	At various locations in the state of Haryana
1	Maximum ambient temperature (°C)	60
2	Minimum ambient air temperature (°C)	-5
3	Maximum average daily ambient temperature (°C)	40

Sno.	Location	At various locations in the state of Haryana
4	Maximum yearly weighed average ambient temperature (°C)	32
5	Maximum altitude above mean sea level (m)	1000
6	Minimum Relative Humidity (%)	26
7	Maximum Relative Humidity (%)	95
8	Average no of Rainy days/ year	120
9	Average annual rainfall	900 mm
10	Maximum wind pressure	195 kg/m sq.

25.6. TYPE TESTS:

- (a.) The bidder shall furnish valid and authenticated type test certificate from a Govt. approved/ a Govt. recognized/ NABL accredited laboratory/ ILAC i.e. International Laboratory Accredited laboratory / ILAC i.e International Laboratory Accrediation Corporation (In case of foreign laboratory) of similar rating and design of tendered material. Such type test certificates should not be older than five years as on the date of bid opening. For this purpose date of conducting type tests will be considered.
- (b.) The type test certificates by in house laboratory of bidding firm even if it is a Govt approved/ Govt recognized/ NABL accredited Laboratory / ILAC accredited, shall not be accepted, in case of their own bid. This will not apply if bidding firm is Govt. Company/ Public Sector Undertaking.
- (c.) The bidder should furnish documentary evidence in support of the laboratory whose type test have been furnished, that the said laboratory is a Govt/ a Govt. approved/ a Govt. recognized/ NABL accredited laboratory/ ILAC accredited (in case of foreign laboratory)
- (d.) The type test certificates shall be furnished either in original or duly attested by notary.
- (e.) The bids of only those bidders shall be considered to be meeting the type test criteria who furnishes complete type test certificates with the bid as per above provision.
- (f.) However, in the following cases the Bidder is not in a position to furnish Type Test Certificate as mentioned above, the bid of the bidder may be considered meeting the type test criteria if the bidder furnishes an undertaking stating that valid type test certificate from a Govt. approved / Govt. recognized / NABL Accredited laboratory / ILAC Accredited laboratory shall be furnished.

Following type test shall be conducted on Clamps:-

- i. Tensile test
- ii. Temperature test.
- iii. Resistance test.
- iv. Dimensional test.
- v. Galvanizing test
- vi. Short circuit test

The short circuit test shall be accompanied with the detailed dimensional drawing duly signed by the testing agency.

25.7. INSPECTION AND TESTING

- (a.) The material shall be tested and inspected by an authorized inspecting officer of the Nigam before despatch. Samples shall be drawn for inspection/ testing as per provisions of relevant ISS/Purchase Order. The purchaser reserves the right to get the material tested in any testing laboratory before despatch.
- (b.) The suppliers should satisfy themselves that the stores are in accordance with the terms of the contract and fully confirm to required specifications by carrying out a thorough pre-inspection of each quota before tending the same for inspecting to the inspecting officer nominated by the purchaser. Such pre-inspection on the part of the suppliers would minimize the chances of rejection in inspection.

The following shall constitute Acceptance Tests:-

- i) Tensile Test.
- ii) Resistance Test.
- iii) Dimensional Check.
- iv) Galvanizing Test, where applicable.

In the event of order temperature rise test shall be carried out once on one Clamp of each type from the first offered lot in the presence of Purchaser's representative without extra charges.

The following shall constitute Routine Tests:-

- i) Visual inspection.
- ii) Dimensional check

25.8. PACKING: Tenderer shall pack the material in the suitable bag so that the material may not be damaged in the transit.

25.9. DRAWING : The successful bidder will submit the full dimensional drawings on A-3 size paper in triplicate for our approval before commencement of supply. If the successful bidder manufacture the equipment without obtaining approval of drawing, the purchaser will not be responsible if any part is not as per required dimensions. Approval of drawings/work by Purchaser shall not relieve the Supplier of his responsibility and liability for ensuring correctness and correct interpretation of the latest revision of applicable standards, rules and codes of practices.

25.10. DEPARTURE FROM SPECIFICATION : If tenderer wish to depart from the specification in any respect, he should clearly state such departures indicating the reasons thereof. Unless this is done, the departmental specification will hold good and shall be binding on the supplier unless the departures have been approved in writing by the purchaser.

25.11. GUARANTEED TECHNICAL & OTHER PARTICULARS:

The tenderer shall furnish complete guaranteed technical particulars and other particulars of material offered by him in schedule given

Sr. No.	Description	PG Clamp
1	Manufacturer's name and Address	
2	Work address	
3	Reference of standard	
4	Rated normal voltage and current	
5	Breeking load in kg	
6	Electrical resistance in ohm	
7	Short time current	
8	Particulars of material of PG Clamp	
9	Temperature rise above Ambient temperature of 40 degree C, when carrying normal current	
10	Complete weight of one PG clamp.(With nut ,bolt and washers) in Kg	
11	Dimensions of PG clamps	
12	Galvanizing of Nuts and Bolts.	

**26.1. TECHNICAL SPECIFICATION OF HARD DRAWN
STRANDED STEEL CORED ALUMINIUM
CONDUCTORS (ACSR 50,80,100,150 & 200 mm²)**

26.2 SCOPE:

This specification covers the design, manufacture engineering, inspection & testing before dispatch, packing & delivery of 'ACSR' conductors for Overhead Power Distribution I Transmission Lines.

26.3 APPLICABLE STANDARDS:

Except when they conflict with the specific requirements in this specification , the conductors shall comply in all respect with the Indian Standard Specification IS:

Sr. No.	Indian Standards	Title
1	IS:398 (Part 11 /1996)	Specification for Aluminium conductors for overhead lines
2	IS:1778 /1980	Reels & drums for Bare conductor
3	IS:2629	Recommended practice for HOT-dip galvanizing of Iron & Steel
4	IS:4826	Galvanized coating on Round Steel wire
5	IS:5484	EC grade Aluminium rod produced by continuous casting & rolling (First revision)

26.4 CLIMATIC CONDITIONS:

The material to be supplied against this specification shall be suitable for satisfactory operation under the following climatic Conditions.

Sr. No.	Location	A various location in Haryana
1	Maximum ambient air temperature	50 deg C
2	Minimum ambient air temperature	(-)5 deg C
3	Average daily maximum ambient temperature	40 deg C
4	Max yearly weighted average ambient temperature	32 deg C
5	Maximum altitude above mean sea level	1000 meters
6	Minimum relative humidity	26%
7	Maximum relative humidity	100%
8	Average no of rainy days/ year	120
9	Average Annual rainfall	900mm
10	Maximum wind pressure	195 kg/ m sq

The material shall be for use in moderately hot and humid tropical climate, conducive to rust and fungus growth.

26.5 MATERIAL:

The conductor shall be made from the hard drawn Aluminium and galvanized steel wires having mechanical and electrical properties as per clause 5, 6 & 7.

Aluminium and galvanized steel wires shall have physical constants conforming to clause 3 & 4 respectively of IS: 398/ Part-11-1996 or latest version thereof. The hot dipped or electrolytic process galvanized coating on steel wires may be applied. The uniformity of galvanizing and weight of coating shall be in accordance with IS:4826-1976 or latest version thereof.

26.6 SIZES:

The sizes and properties of standard steel-cored Aluminium conductors shall be as under:

Table – 1: Stranded Aluminium Conductors, Galvanized Steel Reinforced

Nominal Aluminium area	Standard and wire diameter		Sectional Area of AI	Total Sectional Area	Approx. Overall dia.	Approx. mass	Calculated resistance at 20° C max	Approx. calculated breaking load
	AI	Steel						
1	2	3	4	5	6	7	8	9
mm ²	mm	mm	mm ²	mm ²	mm	kg/km	ohm/km	kN
50	6/3.35	1/3.35	52.88	61.70	10.05	214	0.5524	18.25
80	6/4.09	1/4.09	78.83	91.97	12.27	319	0.3712	26.91
100	6/4.72	7/1.57	105	118.5	14.15	394	0.2792	32.41
150	30/2.59	7/2.59	158.1	194.9	18.13	726	0.1871	67.34
200	30/3.00	7/3.00	212.1	261.5	21.00	974	0.1390	89.67

26.7 ALUMINIUM WIRES:

The properties of aluminium wires to be used in the construction of the stranded wires shall be as under: -

Table 2 : Aluminium wires used in the construction of stranded, aluminium conductors, galvanised steel reinforced.

Size of conductor	Diameter			Cross Sectional Area of nominal diameter wire	Mass	Resistance at 20° C max	Breaking before standing (min)	Breaking after standing (min)
	Nominal	Min.	Max.					
1	2	3	4	5	6	7	8	9
mm ²	mm	mm	mm	mm ²	kg/k	ohm/km	kN	kN
50 mm ²	3.35	3.32	3.38	8.814	23.82	3.265	1.43	1.36
80 mm ²	4.09	4.05	4.13	13.14	35.51	2.194	2.08	1.98
100 mm ²	4.72	4.67	4.77	17.50	47.30	1.650	2.78	2.64
150 mm ²	2.59	2.56	2.62	5.269	14.24	5.490	0.89	0.85
200 mm ²	3.00	2.97	3.03	7.069	19.11	4.079	1.17	1.11

26.8 STEEL WIRES

The properties of the steel wires to be used in the construction of the stranded steel cored aluminium wires shall be as under: -

TABLE-3: Steel wire used in the construction of aluminium conductors galvanised steel reinforced.

Size of conductor	Diameter			Cross Sectional Area of nominal diameter wire	mass	Breaking Load (min)	
	Nominal	Min.	Max.			before standing	after standing
1	2	3	4	5	6	7	8
mm ²	mm	mm	mm	mm ²	kg/km	kN	kN
50 mm ²	3.35	3.28	3.42	8.814	68.75	11.58	11.00
80 mm ²	4.09	4.01	4.17	13.14	102.48	17.27	16.41
100 mm ²	4.72	4.01	4.17	13.14	102.48	17.27	16.41
150 mm ²	2.59	2.54	2.64	5.269	41.09	6.92	6.57
200 mm ²	3.00	2.94	3.06	7.069	55.13	9.29	8.83

26.9 TOLERANCES ON NOMINAL SIZES:

- A tolerance of 1% shall be permitted on the nominal diameter of Aluminium wire.
- A tolerance of 2% shall be permitted on the nominal diameter of galvanized steel wire.

26.10 FREEDOM FROM DEFECTS:

The wires shall be smooth and free from inequalities, spills and splits. The finished conductor shall be smooth, compact, uniform and free from all imperfections including spills & splits, dirt marks, scratches, abrasions, scuff marks, kinks, dents, press marks, over-riding, looseness, pressure and/or unusual bangle noise on tapping, material inclusions, white rust, powder formation or black spots, dirt, grit etc.

26.11 JOINTS IN WIRES & CONDUCTORS:

26.11.1 Aluminium conductor steel reinforced: -

- a. Ultimate breaking load test on stranded conductor
- b. Surface condition test

The type test report(s) submitted by the bidder/ supplier from any NABL accredited laboratory shall be acceptable for participation of the bidder in the procurement I empanelment process. In case NABL accredited laboratory happens to be that of manufacturer itself added precaution shall be taken to get type test and other tests witnessed in the laboratory by Nigam representative at the time of acceptance of material.

Acceptance Tests:

- a. Visual examination
- b. Measurement of diameters of individual Al. & Steel wires
- c. Measurement of Lay-ratio of each layer
- d. Breaking load of individual wires
- e. Ductility
- f. Wrapping test.
- g. Resistance test on Aluminium wires
- h. Galvanizing test.

Routine Tests:

The routine tests shall be done same as acceptance tests and shall be carried out before & after stranding

26.12 PACKING & MARKING:

- (i) The gross mass for various conductors shall not exceed by more than 10% of the values as mentioned in the relevant IS.
- (ii) The reels shall be of such construction as to assure delivery of the conductor in the field free from displacement and damage and should be able to withstand all stresses due to handling and stringing operations so that conductor surface is not dented, scratched or damaged in any way during transport. The conductor shall be properly lagged on the drums and method of lagging to be employed may be clearly stated
- (iii) Supplier will be required to pack and provide all protective arrangements for the material so as to avoid damages in transit under normal conditions. Supplier shall also be responsible for all losses or damages caused or occasioned by any defect in packing. The conductor shall be wound in non-returnable wooden drums.
 - (a.) The inner end of the conductor length shall be kept out of the reel/drum which shall be properly sealed by the manufacturer. The outer end shall also be suitably fastened on the inside of one of the two flanges to avoid the loosening of conductor-winding during handling/transit.
 - (b.) The direction of rolling of drum shall be marked on the drum.
 - (c.) The conductor shall be tightly and uniformly spooled in the drum. Each turn shall be laid snugly against the side of the proceeding turn.
 - (d.) Waterproof heavy-duty paper/heavy duty polythene sheet be used before wrapping on the inner lagging and after the completion of wrapping of conductor.
- A. The Conductor drum should be suitable for wheel mounting before reeling, cardboard or other suitable material shall be secured drum and inside the flanges of the drum. After reeling the conductor, the exposed surfaces should be wrapped with suitable soft material to save the conductor from dirt and grit. Any space between drum lagging and conductor should be suitably filled with soft filler material compactly packed.
- B. Length & Variation in Lengths: The normal length of various ACSR Conductors shall be as mentioned in the relevant IS.
 - (i) Longer Lengths shall be acceptable.
 - (ii) Short lengths not less than 50% of the standard lengths, shall be acceptable to the maximum extent of 10% of the quantity ordered.
- (i) Marking: The following information shall be marked on each drum:
 - (ii) Manufacturers name.
 - (iii) Trade mark, if any.
 - (iv) Drum or Identification number.
 - (v) Size of conductor.
 - (vi) No. of lengths of conductor
 - (vii) Total length of conductor

- (viii) Gross mass of the packing.
- (ix) Net mass of conductor.
- (x) ISI certification mark.
- (xi) Position of the conductor end
- (xii) Name & Address of the consignee
- (xiii) Month & Year of manufacture
- (xiv) Direction of rolling of drum (arrow marking)

26.13 REJECTION AND RETESTS:

If any one of the test piece first selected for testing fails to pass the tests, three further samples from the same batch shall be selected for testing, one of which shall be from the length from which original test samples was taken unless that length has been withdrawn by the supplier should the test pieces from any of these three additional/samples fail, the batch be deemed not to comply with the standard.

26.14 INSPECTION:

All tests and inspection shall be made at the place of manufacturer unless otherwise specially agreed upon by the manufacturer and the purchaser at the time of purchase. The manufacturer shall afford the inspector representing the purchase all responsible facilities, without charge, to satisfy him that the material is being furnished in accordance with this specification. The purchaser or his authorized representative shall have access at all responsible time to manufacture's works to inspect and witness the tests of the conductor being manufactured, As regards correctness of the length of ACSR Conductor, the same is subject to final checking and measurement by the consignee and the firm shall be responsible for all the shortages, damages etc. if any. The samples are taken for test after stranding and if any selected reel fails in the retest, the manufacture may test each and every reel and submit them for further Inspection. All rejected material should be suitably marked and segregated. No material shall be dispatched from its point of manufacture before it has been satisfactorily inspected and tested unless the Purchaser. In writing waives off the inspection. In the later case also, the conductor shall be dispatched only after satisfactory testing for all tests specified are completed and approved by Purchaser. The UHBVN/DHBVN reserves the right to have the tests carried out at the cost of manufacturer I supplier by an independent agency whenever there is a dispute regarding the quality of supply. The material consumed / destroyed during testing will be to the account of the tenderer. Apart from visual inspection all tests as per IS: 398/ Part-11. 1996 with latest amendments if any shall be performed on the material at the manufacturer's works. Samples for acceptance tests shall be drawn from any point of any length, out of the offered lot. However no of samples shall be as per IS:398, Part-11 Normally the tests to be carried out by the Inspecting officer shall be:-

- (a) Checking of diameter.
- (b) Breaking Load test.
- (c) Resistance Test.
- (d) Lay Ratio test.
- (e) Elongation Test.
- (f) Wrapping test.
- (g) Ductility test.

(h) Galvanizing Test

(i) Visual examination etc.

26.15 CHECKING OF LENGTHS/ WEIGHTS DURING INSPECTION:

The tenderer shall at his own cost provide the necessary arrangements for the purpose of physical and accurate checking of lengths and weights of the conductor in drum(s) at the time of inspection by the Inspecting Officer of the UHBVN/ DHBVN. Out of total quantity of drums offered for inspection the Inspecting Officer of the UHBVN/DHBVN shall carry out inspection as under.

- (a) He will carry out 100% checking of all the drums offered for inspection by weight.
- (b) For check measurement of length, minimum 5% drums of the offered lot shall be considered subject to minimum of 2 numbers.
- (c) The drums for length measurement shall be selected either by keeping in view the maximum difference in weight as recorded on the drums/packing list and actually measured or at random. Normally half of drums to be checked for length/weight shall be selected at random and the remaining half by difference in observed/declared weight method.
- (d) Maximum shortage observed in length in any of the drums check measured shall be applied on all the drums offered in a particular lot, by the Inspecting Officer and declared quantity will be reduced accordingly.
- (e) It should be ensured that the material offered is not short in length/ quantity

26.16 GUARANTEED TECHNICAL PARTICULARS:-

Guaranteed Technical Particulars of the conductor should be given in the Appendix -1 attached herewith the specification. Any other particulars considered necessary by the supplier may also be given in addition to those listed in the Appendix- 1.

26.17 SIS CERTIFICATION MARKS:

The ACSR conductors with BIS (ISI) marking only is required by the Nigam against this tender specification and as such only those tenderers who hold valid BIS license for ACSR conductor need quote against this invitation of tender A copy of BIS license valid on the due date of the tender should be submitted with the offer, duly attested failing which, the offer shall be rejected

APPENDIX –1

GUARANTEED TECHNICAL PARTICULARS OF CONDUCTORS

1. Code word
2. Maker's name, address and country
 - a. Aluminium rods.
 - b. Steel wire/rods.
 - c. Complete Conductor.
3. Stranding and wire diameter.
 - a. Aluminium
 - b. Steel
4. Nominal copper area in sq. mm.
5. Nominal equivalent aluminium area in sq. mm.
6. Cross sectional area in sq. mm. of
 - a. Aluminium strand.
 - b. Steel strand.
 - c. Conductor strand.
7. Actual aluminium area in sq. mm.
8. Dia-meter of complete conductor in mm.
9. Minimum breaking load in KN:
Before Stranding After stranding
 - a. Aluminium wire
 - b. Steel wire
10. Minimum breaking load of conductor.
11. Purity of aluminium rods.
12. Zinc coating
 - a. No. of duration of dips.
 - b. Weight of zinc coating.
13. Maximum working tension of conductor.
14. Weight in Kg. Per KM
 - a. Aluminium
 - b. Steel
 - c. Conductor
15. Resistance in ohms/Km at 20°C
 - a. Aluminium wire.
 - b. ACSR Cond.
16.
 - a. Continuous max. current rating of conductors in still air at 50 °C ambient temperature:
 - b. Temperature rise for above current in °C.

17. Modulus of elasticity (Practical) of the conductor.
18. Coefficient of linear expansion.
 - a. Aluminium
 - b. Steel
 - c. Conductor
19. Percentage of carbon in steel wire rods.
20. Standard length.
21. Tolerance, if any, on standard length.
22. Initial and final sags and tension and string charts whether furnished.
23. No. of standard length in the reel / drum.
24. Dimension of the reel.
25. Weight of the conductor in reel / drum in Kg.
26. Weight of reel / drum in Kg.
27. Gross weight of reel/drum including weight of the conductor.
28. Standard according to which the conductor will be manufactured and tested.
29. Other particulars if any.

27.1. TECHNICAL SPECIFICATION FOR MALE - FEMALE CONTACTS 400 AMPS G.O SWITCHES

27.2. SCOPE:

This specification covers the design, manufacture, testing , supply and delivery (FOR Destination anywhere in Haryana) before dispatch at manufacture/s works of Male- Female contact of 400 Amps for 11 KV G.O. Switches for their use in distribution sub stations/field in Discoms in Haryana as per schedule of requirement

27.3. APPLICABLE STANDARDS:

All material used for manufacturing of Male/Female contacts & Arcing Horns shall comply with the Indian Standard specification IS: 2544, IS: 5340 (Part-III) and IS: 9921 (Part I to V). However, Material manufactured as per any other international standard offering material, quality and workmanship of equivalence or better shall also be acceptable.

27.4. CLIMATIC CONDITIONS:

The Male-Female Contacts shall be suitable for their use in 11 KV 400 amps GO Switches to be installed anywhere in Haryana as per climatic conditions as detailed below:-

Sr. No.	Location	At various locations in the state of Haryana
1	Maximum ambient temperature (°C)	60
2	Minimum ambient air temperature (°C)	-
3	Maximum average daily ambient temperature (°C)	40
4	Maximum yearly weighed average ambient temperature (°C)	32
5	Maximum altitude above mean sea level	1000
6	Minimum Relative Humidity (%)	26
7	Maximum Relative Humidity (%)	95
8	Average no of Rainy days/ year	120
9	Average annual rainfall	900 mm
10	Maximum wind pressure	195 kg/m sq.

The equipment shall be use in moderately hot and humid tropical climate, conducive to rust and fungus growth.

27.5. RATING:

I	Nominalsystemvoltage	11kv
ii	Ratedvoltage	12kv
iii	Ratednormalcurrent	400Amps
iv	RatedFrequency	50HZ
v	Peakcurrentinclosedposition	46KA
vi	Min.Shorttimecurrent	18.42KAfor1sec

27.6. DESIGN FEATURE:

(I) Contact System

The male and female contacts assemblies shall be of sturdy construction and design to ensure

- a. Electro-dynamic withstand ability during short circuits.
- b. Thermal withstand-ability during short circuits
- c. Constant contact pressure even when the live parts of the insulator stacks are subject to tensile stresses due to linear expansion of connected bus bar of flexible conductors either because of temperature variation or strong winds.
- d. Self-wiping action during closing and open
- e. Self-alignment assuring closing of the switch without calling for any adjustment.

(II) Temperature Rise

Maximum temperature attained by any part of the isolating switches when in service at site under continuous JSS and exposed continuously to the direct rays of sun and the air having temperature of 60 degree centigrade shall not exceed the permissible limits fixed by latest edition IS-9921(Part-I to V). Maximum temperature rise under the above noted condition should not exceed the permissible limits when corrected for the difference between ambient temperature at site and the reference ambient temperature in IS-9921 (Part-I to V).

(III) Arcing horns

A set of adjustable arcing horns made from 2 SWG G.I. Wire shall be mounted on each insulator stack of G.O Switch. The supplier shall supply a graph showing impulse and power frequency spark over voltage for various gap settings of arcing horns.

27.7. CURRENT CARRYING PARTS:

Material for Male & female contacts shall be of Brass I Gun Metal. Material of arcing horns shall be of Galvanized iron/wire. Design of isolating contacts shall permit easy maintenance and renewal of contacts.

27.8. COMPLETENESS OF EQUIPMENT:

All fittings, accessories or apparatus which may not have been specially mentioned in this specification but which are otherwise necessary for satisfactory working of male female contacts shall be deemed to have been included in the scope of supply.

27.9. ROUTINE TEST:

Routine tests as per latest edition of IS-9921 (Part-1 to IV) shall be carried out at works of the manufacture.

The following shall comprise Routine Tests:-

1. Measurement of the resistance of the main circuit.
2. Operating test

In addition to above, the following acceptance test shall be carried out

1. Visual examination
2. Dimensional check

Copies of Routine test certificate shall be supplied along with the acceptance tests carried out in the presence of purchaser's authorized representative. All tests reports shall be submitted and shall be got approved by the purchaser or his authorized representative before dispatch.

27.10. PACKING:

All material should be suitably packed for transportation direct to the consignee and the supplier shall be responsible for all damages/losses due to improper packing, . All boxes shall be marked with the signs indicating up and down sides of the boxes and also unpacking instructions considered necessary by the supplier. The contents of boxes shall have place marks corresponding to the number in the packing lists to enable easy identification. The prices quoted by the tenderers shall be deemed to include the cost of packing.

27.11. GUARANTEED TECHNICAL PARTICULARS

Guaranteed technical particulars as detailed in Annexure-E1 shall be submitted alongwith the Tenders without accompanying GTPs shall not be accepted.

1. ANNEXURES

The bidder shall submit the following Annexures (as per format) which are part and parcel of the specification:

Annexure E1: Guaranteed Technical Particular for Male Female contact of 400A GO switch

Annexure E2: Drawing No STD – J2- R2

Annexure: E1

Guaranteed Technical Particular for Male Female contact of 400A GO switch

Male Female Contact of 400A

1	Name of Manufacturer	
2	Voltage Rating	
3	Frequency	
4	Current Rating	
5	Peak current in close condition	
6	Max. allowable temp rise of contact	_____ degree centigrade
7	Nature of contact's coating	Copper strip nickel electroplated
8	Voltage drop across terminals	150Mv at 50A (D.C.) max.
9	Short time current and duration	18.42kA (rms) for 1 sec
10	Material for fixed contact	Brass/Gun metal/ copper
11	Material for moving blades	Brass/Gun metal/ copper suitable to carry 400A current
12	Material for arcing horn	Galvanizes iron/ wire

Annexure: E2

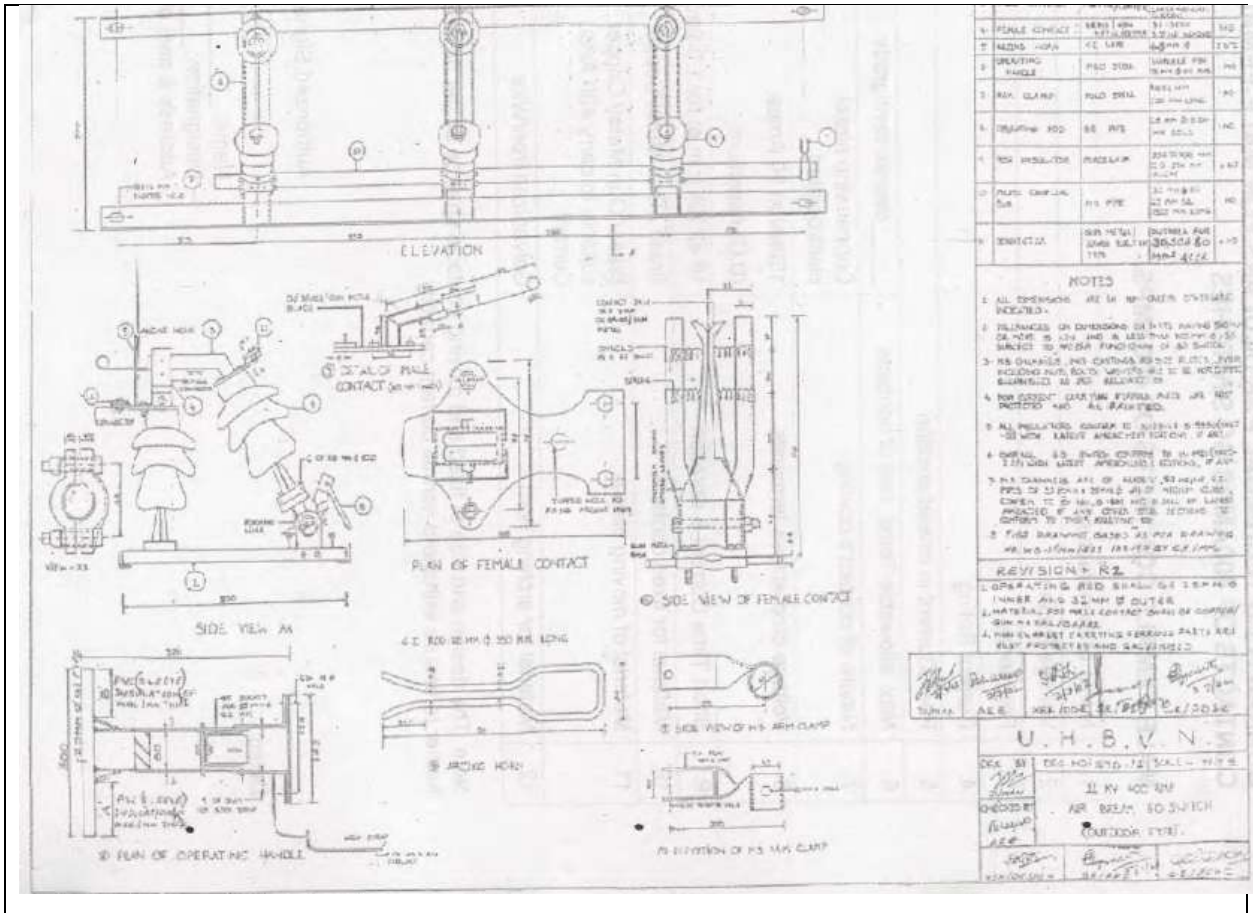

28.1. TECHNICAL SPECIFICATION FOR GSS

(GALVANIZED STAY STRANDED WIRE)

OF 7/8 SWG (4 MM) AND 7/14 SWG (2.24MM)

28.2. SCOPE:

This specification covers the manufacture, testing and inspection of GSS Wire Of sizes 7/8 SWG / (4mm) and 7/14 SWG (2.24mm).

28.3. STANDARDS:

The GSS wires shall conform to IS: 2141-1979, IS-4826 (1979) and 2633 (1964) Or the latest version thereof.

28.4. CLIMATIC CONDITIONS:

The equipment/material to be supplied against this specification shall be suitable for satisfactory operation under the following climatic Conditions

SNo.	Location	At various locations in the state of Haryana
i)	Maximum ambient temperature (°C)	60
ii)	Minimum ambient air temperature (°C)	-5
iii)	Maximum average daily ambient temperature (°C)	40
iv)	Maximum yearly weighed average ambient temperature (°C)	32
v)	Maximum altitude above mean sea level (m)	1000
vi)	Minimum Relative Humidity (%)	26
vii)	Maximum Relative Humidity (%)	95
viii)	Average no of Rainy days/ year	120
ix)	Average annual rainfall	900 mm
x)	Maximum wind pressure	195 kg/m sq.

The equipment shall be for use in moderately hot and humid tropical climate, conducive to rust and fungus growth.

28.5. TECHNICAL PARTICULARS

7/8 SWG

7/14 SWG

- | | | |
|--|--------------|--------------|
| 1. Min, Tensile Strength | 700 N/mm Sq. | 700 N/mm Sq. |
| 2. Min. Breaking load | 5845 Kgf | 1834 Kgf |
| 3. Min Length of Strand without Joints | | |

As per weight of coil (see clause No.8 Packing)) shall be departed by a length not less than that indicated at point (III) under " Technical parameters" and joint in the different wires shall not be less than 15 M apart.

4. TESTS: The tests as per IS: 2141-1979 or its latest version including the tests for chemical analysis is provided therein shall be carried out. The zinc coating of the galvanized wire shall be as specified in IS: 4826/1979 with latest amendments and testing shall be carried out as specified in ISS: 2633/1964 or the latest amendment thereof.
5. INSPECTION: The material shall be inspected and tested before dispatch by an authorized representative of the Nigam in respect of quality. In case the supplier is not in position to get these tests carried out at his works, such tests may got be carried out by him at any Govt. recognized test agency at his own expenses.

6. TEST CERTIFICATES:

The supplier shall supply one set of test certificates from a recognized Govt. agency in respect of quality as per IS: 2141-1979 with latest amendments thereof for approval of the purchaser.

7. MARKING:

Each coil of GSS wire shall be marked legibly with the:

- A. Manufacturer's name or trade mark.
- B. Lot number and coil number.
- C. A brief description and quality of material.
- D. Weight of the coil.
- E. 151 certification mark may also be marked.'

8. PACKING:

The GSS wires shall be supplied in 70-100 kg. Coils, each strands of coils having single continuous length. Each coil of GSS wires shall be suitably bound and fastened compactly and shall be protected by suitable wrapping.

GUARANTEED TECHNICAL DATA:

Sr. No.	Particulars	Units	To be furnished by vendor
1.A	Maker's Name & address		
1.B	Place where the material shall be offered for inspection		
2	Indian Standard specification to which the material confirms		
3	Size of wire		
4.A	Steel wire/Rods		
4.B	Zinc		
4.C	Complete GI wire		
5.A	Diameter	mm	
5.B	Tolerance on diameter	% mm	
	Breaking load	Kgf	
	Weight of zinc coating	gm/m ²	(Min)
	Dip Test	No	
	Wrapping/Bend Test		
A	Adhesion Test		
10.B	GSS Wire after Stranding		
	Lay length	mm	(Min) (Max)
	Overall Diameter	gm/m ²	
	Breaking Load	KN	(min)
A	Elongation	%	(min)
14.B	Individual wire after Stranding		
A	Diameter	mm	(Min) (Max)
15.B	Weight of zinc coating	gm/m ²	(Min)
15.C	Dip test	No	
15.D	Adhesion test		
	Tensile Strength	N/mm ²	
	Coil weight	Kg	(Min) (Max)
	Weight of GSS Wire	Kg/Km	
	Selection area stranded Wire	Sq.mm	
	Chemical composition	A	
	Stranded according to which the wires is manufactured and tested		
	Min. length of strand without joint	mtrs	
23	Packing details indicating bare coil weight	Kg	

29.1. TECHNICAL SPECIFICATION FOR 11KV LIGHTNING ARRESTER

29.2 SCOPE:

This specification covers the technical requirements of design, manufacture, testing, at manufactures works, packing and forwarding supply and unloading 9 kv lightning arrestor at site stores complete with all accessories for efficient and trouble free- operation. The specifications requirements are covered in the enclosed technical data sheet.

29.3 CLIMATIC CONDITIONS:

Sr. No.	Location	At various locations in the state of Haryana
1	Maximum ambient temperature (°C)	60
2	Isoceraunic level	45
3	Minimum ambient air temperature (°C)	-5
4	Maximum average daily ambient temperature (°C)	40
5	Maximum yearly weighed average ambient temperature (°C)	32
6	Maximum altitude above mean sea level	1000
7	Minimum Relative Humidity (%)	26
8	Maximum Relative Humidity (%)	95
9	Average no of Rainy days/ year	120
10	Average annual rainfall	900 mm
11	Maximum wind pressure	195 kg/m sq.
12	Pollution	Moderate

The atmosphere is generally laden with mild acid and dust in suspension during the dry months and is subjected to fog in cold months. Heavy lightning occurs in the area during rainy months (June to October). All equipment shall be designed to withstand seismic forces corresponding to an acceleration of 0.1g.

29.4 APPLICABLE STANDARDS:

The equipment covered by this specification shall unless otherwise stated, be designed, constructed and tested in accordance with latest revisions of relevant Indian / IEC / other applicable standards shall conform to the regulations of local statutory authorities.

IS-3070:1993 (part-3) reaffirmed 2004	Specifications for lightning arresters for alternating current system.
IS-4759:1196 reaffirmed 2004	Hot dip-zinc coating on structural steel and other allied products
IS-2633:1986 reaffirmed 2004	Method for testing uniformity of coating on zinc allied products
IS-6209:1982 reaffirmed 2004	Method of partial discharge measurement
IS-6745:1972 reaffirmed 2006	Method for determination of mass of zinc coating on zinc coated iron and steel articles.
EC-60099:2009-05 Part -4	Specifications for surge arrestor without gap for AC System

29.5 GENERAL TECHNICAL REQUIREMENTS:

Sr. No.	Description	Requirements
1	Installation	Outdoor
2	Type	Metal oxide
3	Service Voltage	11 kV
4	Rated Voltage	12 kV
5	Rated Frequency	50 Hz
6	Maximum continue operating voltage (MCOV)	7.65 kV(rms)
7	Arrester Rating	9 kV (rms)
8	Nominal Discharge Current	5kA
9	Distribution class	Distribution (Class-2)
10	Voltage withstand on Arrester Housing	
10.1	Power Frequency Voltage (Dry/Wet)	28 kV (rms)
10.2	Lightning Impulse Voltage (kV Peak)	75kV (peak)
11	Lightning Impulse Protection Level	30 kA
12	Long Duration- Current Requirement	
12.1	Peak current	75 A
12.2	Virtual duration of peak T	1000 T (micro sec)
13	High current impulse operating duty	65 (kAP)
14	Creepage distance of Arrester housing	25mm/kV
15	Partial Discharge at 1.5 times MCOV	< 10 pc
16	Disconnecter	As per IEC 60099
17	Max. cantilever strength	325 M

29.6 GENERAL CONSTRUCTIONS:

Lighting arresters shall be distribution class, zinc oxide and gapless type suitable for operation under the system conditions specified this shall be self-supporting structure mounting type. Each unit of arrester assembly shall be hermetically sealed, leak tested and protected against ingress of moisture and shall be individual demountable. The seal shall be properly designed and tested for operation under extreme weather conditions.

29.7 Assembly

Lighting arrester shall be supplied along with the insulating base, terminal connector and necessary hardware. The Assembly consists of a stack of Metal Oxide elements. All metal parts shall be of non-rusting and non-corroding metal. Bolts, screws and pins shall be provided with lock washers, lightning arrester construction shall be suitable to withstand Seismic Loading, Short Circuit Forces and wind load and the force exerted of the arrester base and to the terminal imposed by the line conductor. All similar parts, particularly removable ones, shall be interchangeable.

Housing shall be polymeric to provide thermal dissipation of heat generated in the metal oxide elements during overvoltage and line discharge. Polymeric housing shall be free from flaws affecting the mechanical and electrical strength of the arrester. Housing shall be capable to withstand the desired pollution stresses without flashover. Arrester shall be capable to withstand the temperature rise due to the non-uniform field distribution, caused by the pollution on the surface of the housing.

The arrester shall have thermal stability to withstand the heat generated from the ZnO element due to continuous operating voltage and surges, it shall be less than the Thermal power dissipation of the housing and the element shall remain in an undamaged condition, capable protective function.

Earth Terminals shall be provided with the Lightning Arrester.

29.8 Disconnecter:

Each Individual unit of Lightning Arrester with Disconnecter shall be hermetically sealed and fully protected against ingress of moisture. The hermetic seal shall be effective for the entire life time of the Lightning Arrester with Disconnecter under the specified service conditions. Disconnecter shall give the visible indication of the failed arrester. The Lightning Arrester with disconnecter shall be suitable for bracket type mounting." Disconnecter shall be suitable for screwing directly to LA with terminal of M10

The corresponding units of Lightning Arrester with "disconnecter of the same rating shall be interchangeable without adversely affecting the performance. All the necessary flanges, bolts, nuts, clamps etc. required for assembly of complete Lightning Arrester with disconnecter and accessories and mounting on purchaser's support structure shall be included in bidder's scope of supply. The mounting details for mounting the Lightning Arrester with disconnecter on purchaser's support shall be given along with bid.

29.9 NAME PLATE & MARKING:

Lighting arrester shall be provided with durable and legible name plate, effectively secured against removal. The name plate shall be indelibly and distinctly marked with all material particulars as per the relevant standards along with the following

- (a) The name plate shall be embossed with / P.O. no. with date & ‘Property of DHBVN’.
- (b) Rated Voltage
- (c) Rated Frequency
- (d) Nominal Discharge Current
- (e) Manufacturer Name
- (f) Type and Identification of complete Arrester
- (g) Year of Manufacture
- (h) Serial Number

29.10 TEST

All routine, acceptance and type test shall be carried out in accordance with the relevant IS/IEC. All routine/ acceptance tests shall be witness by purchaser / his authorized representative. All components and fittings shall be type tested as per relevant standard. Following tests shall be necessarily conducted on the Lightning arrester in addition to other specified in IS/IEC standard.

29.11 Routine Test

1. Measurement of reference voltage test
2. Residual voltage test on complete arrester
3. Satisfactory absence from partial discharges and contact noise shall be made on each unit by any sensitive method adopted by the manufacturer on arrester.
4. Internal partial discharge test

29.12 Acceptance Test:

1. Measurement of power frequency reference voltage
2. Lightning impulse residual voltage on the complete arrester

3. Partial discharge test
4. For arrester units with sealed housing leakage check shall be made on each unit by any sensitive method adopted by the manufacturer on the arrestor and on surge monitor.
5. Visual inspection.

29.13 Type Test:

1. Insulation withstand test
2. Residual voltage test
3. Long duration current withstand test
4. Operating duty test
5. Test on arrester disconnecter (Time current characteristics)
6. Galvanizing test on exposed steel metal parts
7. Moisture ingress test and water immersed test
8. Short circuit test (Low/High current)
9. Weather aging test
10. Internal partial discharge test
11. Dry and wet partial frequency voltage test
12. Power frequency (voltage vs time curve)
13. Seal leak rate test

29.14 Special thermal stability test

The test requires additional agreement between manufacturer and purchaser prior to commencement of arrester assembly.

29.15 TYPE TEST CERTIFICATE:

The bidder shall furnish the type test certificate as mention above as per the corresponding standards. All test shall be conducted at CPRI/ERDA as per the relevant standards. Type test should have been conducted in certified test lab during the period not exceeding 5 year from date of opening the bid. In event of any discrepancy in the test report, i.e. any test report not acceptable same shall be carried out without any cost implication to purchaser.

29.16 PREDISPATCH INSPECTION

Equipment shall be subject to inspection by authorized representative of the purchaser inspection may be made at any stage of manufacturer at the option of purchaser and the equipment if found unsatisfactory as to workmanship or material, the same is liable to rejection. Bidder shall grant free access to places of manufacture to purchaser's representatives at all times when work is in progress. Inspection by purchaser or its authorized representative shall not relieve the supplier of his obligation of furnishing equipment in accordance with specifications. Material shall be dispatched after specific MDCC (Material Dispatched Clearance Certificate) is issue by purchaser. Following document shall sent along with material.

- (a) Test Reports
- (b) MDCC issued by DHBVN
- (c) Invoice in duplicate
- (d) Packing list
- (e) Drawing and catalogue
- (f) Guarantee/warranty card
- (g) Delivery challan
- (h) Other documents (as applicable)

29.17 INSPECTION AFTER RECEIVED AT STORE

The material received at purchaser store shall be inspected for acceptance and shall be liable for rejection in found different from reports of the pre dispatch inspection and one copy of the report shall be sent to DHBVN.

29.18 GUARANTEE

Bidder shall stand guarantee towards design, material, workmanship and quality of process/manufacturing of items under the contract for due and intended performance of the same, as an integrated product delivered under this contract. In event of any defect is found by the company upto period of 12 months from the date of commissioning on 18 months from date of last supplies made under the contract whichever is earlier, supplier shall be liable to undertake to replace/rectify such defects at his own cost. Within mutually agreed timeframe, and to entire satisfaction of the company, failing which the company will be at liberty to get it replaced/rectified at supplier's risk and cost and recover all such expenses plus company's own charges of @ 20 X of expenses incurred from supplier or from "Security cum performance deposit" as the case may be. Bidder shall further be responsible for 'free replacement for another period of THREE years from the end of the guarantee period for any later defect if noticed and reported by the company.

29.19 PACKING

Bidder shall ensure that all equipments covered by the specification shall be prepared for rail/road transport/local equipment) and be packed in such a manner as to protect it from damage.

29.20 QUALITY CONTROL

The bidder shall submit with the offer, quality assurance plan indicating the various stages of inspection the tests and checks which will be carried out on the material reconstruction components during manufacturer and after finishing, brought out items and fully assembled components and equipment including drives. As part of plan, a schedule for stage and final inspection within the parameters of the delivery schedule shall be furnished. The purchaser's engineer or its nominated representative shall have free access to the manufacturer/sub supplier's works to carry inspection.

29.21 MINIMUM TESTING FACILITIES:

The bidder shall have inhouse testing facilities for carrying out all routine tests and acceptance tests as per relevant international/indian standard.

29.22 MANUFACTURING ACTIVITIES

The successful bidder will have to submit the bar chart for various manufacturing activities. This bar chart shall be inline with quality assurance plan submitted with the offer. The bar chart will have to be submitted within 15 days from the release of order.

29.23 DRAWING AND DOCUMENTS

Following drawings and documents shall be prepared based on purchaser's specifications and statutory requirements and detail submitted with the bid.

- (a) Completely filled in Technical Particulars
- (b) General Description of equipment and components including brochures
- (c) General arrangement drawing for lightning arrester
- (d) Foundation plan
- (e) Bill of material
- (f) Experience list
- (g) Type test certificate

After award of contract, four (4) set of drawings drawn to scale, describing the equipments in detail shall be forwarded for approval and shall subsequently provide four (4) complete set of final drawing, one shall be auto positive suitable for reproduction, before the dispatch of three equipment. Soft copy (Compact Disk) of all drawings, GTP, Test certificates shall be submitted after final approval of the same to purchaser.

Following drawings/ documents shall be submitted by the bidder for purchaser approval

Sr. No.	Description	For Approval	For Information	Review	For Submission	Final
1	Technical Particulars	√	√		√	
2	General arrangement drawings	√	√		√	
3	Terminal and connection drawing	√	√		√	
4	Manual/ catalogue	√	√		√	
5	Installation/ commissioning manual	√	√		√	
6	Instruction for use	√	√		√	
7	Transport/shipping dimensional drawing	√	√		√	
8	QA and QC plan	√	√		√	
9	Routine, Acceptance and type test certificate	√	√		√	

All the documents and drawings shall be in English language instruction manual: Bidder shall furnished two soft copies (CD) and four (4) hard copy of nicely bound manuals (in English language) covering erection and maintenance instruction and all relevant information and drawing pertaining to main equipments and auxiliary devices.

29.24 GUARANTEED TECHNICAL PARTICULARS

Sr. No.	Description	Units	To be specified by bidders
1	Manufacturer		
2	Model No.		
3	Installation		
4	Type		
5	Service Voltage	kV (rms)	
6	Rated voltage	kV (rms)	
7	Rated Frequency	Hz	
8	Maximum continuous operating voltage (MCOV)	kV (rms)	
9	Arrester Rating	kV (rms)	
10	Nominal discharge current	kA	
11	Distribution class		
12	Voltage withstand arrester housing	kV	
12.1	Power frequency voltage (Dry/Wet)	kV	
12.2	Lightning Impulse voltage	kVp	
13	Lightning impulse protection level	kA	
14	Long Duration current requirement	kA	
14.1	Peak current	A	
14.2	Virtual duration of peak	T micro sec	
15	Partial discharge	As per provision of IEC – 99 – 4 (latest amended)	
16	Creepage distance of arrester	Mm	
18	Disconnecter		
19	Cantilever strength	Kgm	
20	Reference current	mA	
21	Reference voltage at reference current		

30.1. TECHNICAL SPECIFICATION FOR GALVANISED STEEL BARBED WIRE

30.2. SCOPE:

This Specification covers the manufacture, testing & inspecting of galvanized steel barbed wire (glidden type) formed with 2 line wires twisted together, one containing the barbs.

30.3. APPLICABLE STANDARD:

Except when they conflict with the specific requirements in this specification, the conductors shall comply in all respect with the Indian standard specification No. IS: 278 (1978) & 4826 (1979) or the latest version thereof.

30.4. CLIMATIC CONDITIONS:

The Barbed wire is required to work satisfactorily under the following climatic conditions

Sr. No.	Location	At various locations in the state of Haryana
(i)	Maximum ambient temperature (°C)	60
(ii)	Minimum ambient air temperature (°C)	-5
(iii)	Maximum average daily ambient temperature (°C)	40
(iv)	Maximum yearly weighed average ambient temperature (°C)	32
(v)	Maximum altitude above mean sea level (m)	1000
(vi)	Minimum Relative Humidity (%)	26
(vii)	Maximum Relative Humidity (%)	95
(viii)	Average no. of Rainy days/ year	120
(ix)	Average annual rainfall	900 mm
(x)	Maximum wind pressure	/m sq.

30.5. TECHNICAL PARTICULAR:

(i)	Nominal dia meter of line wire:	2.24 mm ± 0.08 mm
(ii)	Nominal dia meter of point wire:	2.00 mm ± 0.08 mm
(iii)	Nominal distane between two barbs:	75 mm ± 12 mm
(iv)	Weight of completed barbed wire:	Max. 106 g/M Min. 97 g/M
(v)	Tensile strength of wire	40 to 60 Kg f/mm
(vi)	Minimum breaking load of completed Barbed wire	300 Kgf.

30.6. TESTS:

The tests as per IS:278/1978 including the tests for chemical analysis provided therein shall be carried out. The uniformity of zinc coating shall be treated as specified in IS: 4826-1979.

30.7. TEST CERTIFICATE:

The supplier shall supply one set of certificates from recognized govt. agency in respect of quality as per IS: 278-1979 with latest amendments for approval of the purchaser.

30.8. MARKING:

Each coil of barbed wire shall be legibly marked with the name of the manufacturer, the type of the barbed wire, the diameter of the line & point wire/barb spacing and length & weight of the coil. Barbed wire may also be marked with IST certification mark.

INSPECTION: All tests & inspection shall be made at the place of manufacture unless otherwise especially agreed upon by the manufacturer and the purchaser at the time of purchase. The manufacturer shall afford the inspector / representing of the purchaser all reasonable facilities, without charge, to satisfy him that the material is being furnished in accordance with this specification. The purchaser or his authorised representative shall have access at all reasonable times to manufacturer's works to inspect & witness tests of the conductor being manufactured. As regards correctness of the length of galvanized steel barbed wire, the same is subject final checking and measurement by the consignee & the firm shall be responsible for all shortages, damages etc, if any.

The manufacturer shall be responsible to pay penalty of Rs 20,000/-for each occasion at which the fake inspection call has been made or the material is rejected during testing/inspection by the authorized agency/representative of the Nigam. This penalty would be in addition to the expenses incurred by the Nigam in deputing the Inspecting Officer, carrying out such inspection.

30.9. GUARANTEED TECHNICAL PARTICULARS:

Guaranteed technical particulars of the barbed wire should be given in the Annexure 'E3' attached herewith the specification. Any other particulars considered necessary by the supplier may also be given in addition to these listed in the Annexure.

30.10. PACKING & WEIGHT OF COIL:

The barbed wire shall be supply in coils weighting 15 Kgs to 30 Kgs.

30.11. CHALLENGE CLAUSE:

The Supplier shall ensure that the packing list and bill of material are approved by the purchaser before dispatch. The material offered/received after the inspection by the authorized Inspecting Officer may again be subjected to the test for losses or any other parameters from any testing house/in house technique of the Nigam having requisite capabilities and facilities. The results if found deviating/ unacceptable or non-complying to approved GTPs the lot shall be rejected and bidder shall arrange to supply the replacement within thirty (30) days of such detection at his cost including to & fro transportation. In addition to this penalty @10% of cost of the inspected lot of material shall be imposed

Annexure E3:

GUARANTEED TECHNICAL PARTICULARS OF GALVANISED STEEL BARBED WIRE

1. Code word.
2. Maker's name address & country
3. Nominal dia meter of line wire
4. Nominal distance between two barbs:
5. Tensile strength of wire.
6. Minimum breaking load of barbed wire.
7. Weight of complete barbed wire.
8. Nominal dia meter of point wire.
9. Standard length.
10. Tolerance, if any.
11. Standard to which confirm.
i) Galvanising. ii) Barbed wire.
12. Other particulars, if any.

31.1. TECHNICAL SPECIFICATION FOR PORCELAIN INSULATORS AND INSULATORS FITTINGS FOR 11 KV OVERHEAD LINES

31.2 SCOPE:

This specification covers the details of the porcelain insulators and insulator fittings for use on 11 KV overhead power lines met with in rural Electric distribution systems.

31.3 APPLICABLE STANDARDS:

Except when they conflict with the specific requirements of this specification, the insulators shall comply with the Indian Standard Specification IS: 731 – 1971 or the latest version thereof and the insulator fittings shall comply with the Indian Standard Specification IS: 2486 (Part-I), IS – 2486 (Part-II) 1974 & IS: 3188 or the latest version thereof or equivalent international standards.

31.4 CLIMATIC CONDITIONS:

The equipment is required to operate satisfactory under the following site conditions:

1.	Max. ambient air temperature	60°C
2.	Min. ambient air temperature	(-)5°C
3.	Average Daily Max. ambient temperature	40°C
4.	Max. yearly weighted average ambient temperature	32°C
5.	Max. altitude above mean sea level (Meters)	1000
6.	Minimum Relative Humidity (%age)	26
7.	Max. Relative Humidity (%age)	95
8.	Avg. No. of Rainy days/year	120
9.	Avg. annual rainfall	900 mm
10.	Maximum wind pressure	195 Kg./m Sq.

31.5 GENERAL REQUIREMENT:

- (i) The porcelain shall be sound free from defects thoroughly vitrified and smoothly glazed.
- (ii) Unless otherwise specified, the glaze shall be brown in colours. The glaze shall cover all the porcelain parts of the insulator except those areas which serve as support during firing or are left unglazed for the purpose of assembly.
- (iii) The design of the insulator shall be such that stresses due to expansion and contraction in any part of the insulator shall not lead to deterioration. The porcelain shall not engage directly with hard metal.
- (iv) Cement used in the construction of the insulator shall not cause fracture kby expansion or loosing by contraction and proper care shall be taken to locate the individual parts correctly during cementing. The cement shall not give rise to chemical reaction with metal fittings and its thickness shall be as uniform as possible.

- (v) The insulators should preferably be manufactured in automatic temperature controlled kilns to obtain uniform baking and better electrical & mechanical properties.

31.6 CLASSIFICATION AND DIMENSIONS:

- Both pin & strain insulators shall conform to type B of IS: 731.
- The dimension of pin insulators shall be as shown in the drawings.
- The strain insulators shall be ball & socket type or Tongue & clevis type, as required by the purchaser. The dimensions of these insulators shall be as per IS: 2486 (Part-II).

31.7 TEST VOLTAGES:

The test voltages of insulators shall be as under:

Highest system voltage	Visible discharge test	Wet power frequency Withstand test.	Power frequency puncture withstand test (Pin Insulators)	Power frequency Puncture withstand test (Strain Insulators)	Impulse voltage withstand test.
KV12(rms)	KV (rms) 9	KV 35(rms)	KV 105(rms)	KV (rms)1.3 times the actual dry flash over voltage of insulator	KV 75(Peak)

31.8 FAILING LOAD:

- Electro mechanical failing load (for Pin Insulators only). The insulators shall be suitable for a minimum failing load of 5 KN applied in transverse direction.
- Electro mechanical failing load (for strain insulators only). The insulators shall be suitable for a minimum failing load of 45 KN applied in axially.

31.9 CREEPAGE DISTANCE:

The maximum creepage distance shall be as under:

Highest system voltage	Normal & moderately polluted atmosphere	Heavily polluted Atmosphere	
		Pin Insulator	strain insulator
12 KV	230 mm	320 mm	400 mm

Higher value of creepage distance has been specified for strain insulators as these are normally used in horizontal position in 11 KV lines.

31.10 TESTS:

The insulators shall comply with the following tests as per IS – 731 or equivalent international standards.

31.11 TYPE TESTS:

The following shall constitute the type tests:

- a) Visual examination.
- b) Verification of dimensions.
- c) Impulse voltage withstand test.
- d) Wet power frequency voltage withstand test.
- e) Temperature cycles test.
- f) Electro – mechanical failing load test. (for strain insulator only).
- g) Mechanical failing load test. (for Pin Insulator only).
- h) Puncture test.
- i) Porosity test.
- j) Galvanizing test.
- k) Visible discharge test.
- l) 24 hours mechanical strength test. (for strain insulators only).

31.12 ACCEPTANCE TESTS:

The test samples after having withstood the routine test shall be subjected to the following acceptance tests in the order indicated below:

- a) Verification of dimensions.
- b) Temperature cycle tests.
- c) Electro mechanical failing load test (for strain insulator only).
- d) Puncture test (for strain insulator only).
- e) Porosity test and.
- f) Galvanizing test.

31.13 ROUTINE TESTS:

The following test shall be carried out as routine tests:

- a) Visual examination.
- b) Mechanical routine test (for strain insulator only).
- c) Electrical routine test. (for strain insulator only).

31.14 MARKING:

Each insulator shall be legibly and indelibly marked to show the following:

- a) Name or trade mark of the manufacturer.
- b) Month and year of manufacture.
- c) Min. failing load in KN.

d) ISI certification mark, if any.

Marking on porcelain shall be printed and shall be applied before firing.

31.15 PACKING:

All insulators (without fittings) shall be packed in wooden crates suitable for easy and rough handling and acceptable for rail transport, where more than one insulator is packed in a crate wooden separators shall be fixed between the insulators to keep individual insulator in position without movement within the crate.

32.1 PART-B INSULATOR FITTINGS:

32.2 SCOPE :

This specification covers details and test requirements for:

- 1) Pins for 11 KV Pin Insulators.
- 2) Fittings for strain insulators.

32.3 APPLICABLE STANDARD:

Pins shall comply with the requirements of IS: 2486 (Part – I & II) with latest amendments. Fitting for strain insulator shall comply with the requirements of IS: 2486, Part-I to IV with latest amendments or equivalent international standards.

32.4 PINS FOR PIN INSULATORS

32.5 General Requirements:

The pins shall be a single piece obtained preferably by the process of forging. They shall not be made by joining, welding, shrink fitting or any other process from more than one piece of material. They shall be of good finish, free from flaws and other defects. The finish of the cellar shall be such that a sharp angle between the cellar and the shank is avoided.

All ferrous pins, nuts & washer except those made of stainless steel shall be galvanized. The threads of nuts & tapped holes shall be cut after galvanizing and shall be well oiled or greased.

32.6 Dimensions:

Pins shall be of small steel head type S-I as per IS : 3486 (Part – II) having stalk length of 165 mm and shank length of 150mm with minimum failing load of 5 KN.

32.7 Test:

Insulator pins shall comply with the following test as per IS: 2486 (Part-I) or equivalent international standards.

32.8 Acceptance Test:

- (a) Checking of threads on heads.
- (b) Galvanizing test.
- (c) Mechanical test.

32.9 Routine Test:

- (a) Visual examination test.

32.10 Type Test:

- (a) Checking of threads on heads.
- (b) Galvanizing test.
- (c) Mechanical test.
- (d) Visual examination test.

32.11 STRAIN (DISC) INSULATORS SETS:

32.12 General Requirements:

All forging and casting shall be of good finish and free from laws and other defects. All edges on the outside of fittings such as at the eye, clevis & holes, shall be rounded. All parts of different fittings which provide for interconnection shall be made such that sufficient clearance is provided at the connection point to ensure free movement and suspension of the insulator string assembly. All eye and clevis connections shall be free but the care shall be taken that too much clearance between eye & the tongues of the clevis is avoided.

All ferrous fittings and the parts other than those stain less steel, shall be galvanized, small fittings like spring washers, nuts etc. may be electroplated with zinc.

32.12.1 TYPE:

Clevis and tongue type insulator set shall be supplied, the nominal dimensions of the clevis and tongue type insulator set shall be as given in IS: 2486.

32.12.2 TESTS:

Strain insulator sets shall comply with the following tests as per IS: 2486 (Part – I).

32.12.2.1 TYPE TESTS:

- (a) Mechanical test.
- (b) Electrical resistance test (for tension clamps only).
- (c) Heating cycles test (for tension clamps only).

32.12.2.2 SAMPLE TEST:

- (a) Dimensional.
- (b) Galvanizing check electroplating test.

32.12.2.3 ROUTINE TEST:

- (a) Visual check.
- (b) Mechanical test.

32.13 STRAIN CLAMPS:

Suitable aluminium alloys clamps shall be provided alongwith the fittings to suit ACSR conductors 7/2. 11 mm – 7/3. 35mm. The ultimate strength of clamps should not be less than 3000 Kgs.

32.14 MARKING:

The caps and clamps shall have mark on them with the following information :

- (a) Name or trade mark of the manufacture.
- (b) Country of manufacture.

32.15 PACKING :

For packing of GI pins, strain clamps & related hardware, double gunny bags or wooden cases if deemed necessary shall be employed. The heads & threads portions of pins & the fittings shall be properly protected against damage. The gross weight of the packing shall not normally exceed 50 Kg. Different fittings shall

be packed in different bags or cases and shall be complete with their minor accessories fitted in place. All nuts shall be hand tightened over the bolts & screwed up to the farthest point.

The packages containing fittings may also be marked with the ISI certification mark.

32.16 TEST & TEST CERTIFICATES :

The tenderers shall submit Photostat copies of all the tests including type test as prescribed in the relevant ISS from any accredited laboratory

32.17 GUARANTEED & OTHER TECHNICAL PARTICULARS :

These particulars shall be furnished strictly as per Annexure –‘E4’ in duplicate. Any deviation from this specification shall be clearly brought out separately.

32.18 PLACE OF MANUFACTURE :

The tender shall state the place of manufacturer, testing and name of the manufacturer of the various items included in his Tender.

32.19 INSPECTION :

Inspection of material and supervision of test in accordance with the relevant standards as mentioned in clause 2 & 13 above and supporting drawing and schedules, and approved manufacturer specification shall be carried out by the purchaser or his duly authorized representative. The material shall be inspected and tested before dispatch by an authorized representative of the DHBVN in respect of quality. The manufacturer shall provide to the inspecting officer all reasonable facilities without charge to satisfy him that the material is being furnished in accordance with the specification.

The purchaser or his authorized representative shall have access to all reasonable time to manufacturer’s works to inspect and witness the test of the equipment manufactured.

The purchaser has the right to have the tests carried out at the cost of supplier by an independent Govt. agency wherever there is a dispute regarding the quality of material supplied.

The manufacturer shall be responsible to pay penalty of Rs 20,000/- for each occasion at which the fake inspection call has been made or the material is rejected during testing/inspection by the authorized agency/representative of the Nigam. This penalty would be in addition to the expenses incurred by the Nigam in deputing the Inspecting Officer, carrying out such inspection.

32.20 Challenge Clause:

The material offered/received after the inspection by the authorized inspecting officer may again be subjected to the test for or any parameter from any testing house/in-house technique of the Nigam & the results if found deviating un-acceptable or not complying to approved GTPs the bidder shall arrange to supply the replacement within thirty (30) days of such detection at his cost including to & fro transportation. In addition , penalty @10% of cost of the inspected lot of material shall be imposed.

32.21 Warranty Period:

The supplier shall be responsible to replace, free of cost, with no transportation or insurance cost to the purchaser, up to destination, the whole or any part to the material which in normal and proper use proves the defective in quality or workmanship, subject to the condition that the defect is noticed within 18 months from the date of receipt of material in stores or 12 months from the date of commissioning whichever period may expire earlier. The consignee or nay other officer of Nigam actually using the material will give prompt

notice of each such defect to the supplier. The replacement shall be effected by the supplier within a reasonable time, but not, in any case, exceeding 45 days. The supplier shall, also, arrange to remove the defective within a reasonable period, but not exceeding 45 days from the date of issue of notice in respect thereof, failing which, the purchaser reserve the right to dispose of defective material in any manner considered fit by him (purchaser), at the sole risk and cost of the supplier. Any sale proceeds of the defective material after meeting the expenses incurred on its custody, disposal handling etc., shall however be credited to the supplier's account and set off against any outstanding dues of the purchaser against the supplier. The warranty for 12/18 months shall be one time.

4. ANNEXURE –E4

GURANTEED TECHNICAL PARTICULARS OF PORCELAIN INSULATORS FOR

11KV OVERHEAD POWER LINE :

1. Maker's name and country.
2. Nominal voltage.
3. Highest voltage.
4. Dry one minute power frequencies withstand voltage.
5. Wet Dry one minute power frequencies withstand voltage.
6. Power frequencies withstand voltage.
7. Impulse withstand voltage (1/50 second positive waves).
8. Visible discharge test voltage.
9. Impulse flashover voltage (1/50 micro second positive waves).
10. Impulse flashover voltage (1/50 micro second negative waves).
11. Dry flashover voltage.
12. Wet flashover voltage.
13. Min. failing load.
14. Minimum creepage distance.
15. Weight per unit.
16. Size of insulators.
17. Standard to which the insulator shall be manufactured and tested.
18. Tolerance in dimensions, if any.

33.1. TECHNICAL SPECIFICATIONS FOR

HEAT SHRINKABLE /PUSH ON

TYPE TERMINATIONS FOR 11 KV XLPE CABLES

33.2 SCOPE

This specification covers the design, manufacture/assembly and testing of heat shrinkable / push on type terminations suitable for 11 KV 3-core XLPE insulated, screened, armoured, with aluminium conductor cables suitable for earthed system and conforming to IS: 7098 (Par-II) – 1985 with latest amendment, if any

33.3 STANDARD

The performance as well as type test requirements of all type of kits referred under scope shall conform to stipulations of IS: 13573/2011 or VDE-0278 with latest amendments, if any.

All the electrical & physical parameters of terminations should also conform to the corresponding parameters of XLPE cables referred under ‘SCOPE’ of this specification, as per IS: 7098 (Part-II)- 1985 (with latest amendments, if any) or equivalent international standards

33.4 CLIMATIC CONDITIONS

I.	Maximum ambient temperature (°C)	60
II.	Minimum ambient temperature (°C)	-5
III.	Maximum average daily ambient temperature (°C)	40
IV.	Maximum yearly weighed average ambient temperature	32
V.	Maximum altitude above mean sea level (m)	1000
VI.	Minimum Relative Humidity (%)	26
VII.	Maximum Relative Humidity (%)	95
VIII.	Average no of Rainy days/year	120
IX.	Average annual rainfall	900 mm
X.	Maximum wind pressure	195 kg/m sq.

The material shall be for use in moderately hot and humid tropical climate, conducive to rust and fungus growth

33.5 REQUIREMENT

The heat shrinkable/push on type terminations offered shall be of proven design and make, which have already been extensively used and fully type tested.

33.6 GENERAL REQUIREMENT

The Purpose of this specification to specify the performance of termination kits for the use on 50 C/S 3 phase system with earthed neutral for working voltage of 11 KV. Earthing arrangement shall be as per relevant standard and details of earthing arrangement offered shall be submitted alongwith the tender.

33.7 The material to be used should be inert and capable for resisting degradation during the service of cable system. The kit shall be provided with protection against rodents and termite attack.

33.8 Heat Shrinkable Type (Terminations):

- 33.8.8 The term heat shrinkable refers to extruded or moulded polymeric materials which are cross-linked to develop elastic memory and supplied in expanded or otherwise deformed size/shape, subsequently heating in a non-constrained state to a temperature above the shrink temperature resulting in the material recovering or shrinking to its original-shape.
- 33.8.9 Since the sealant or adhesives (to be used for environment sealing) between the heat shrinkable materials and XLPE cables shall be exposed to high electrical stresses, they must be track resistant.
- 33.8.10 The heat shrinkable polymer materials being used for external leakage insulation between the high voltage of conductors and grounds should be weather resistant.
- 33.8.11 All cuts/nicks inadvertently occurred to XLPE insulation must be rendered discharge free by using suitable discharge suppression compound.
- 33.8.12 The heat shrinkable tubing may be either extruded or moulded type.
- 33.8.13 Higher thickness of heat shrinkable sleeves shall be preferable to counter erosion due to pollution.

33.9 Push on type (Terminations only):

- 33.9.8 Rubber components should be made from proven quality of rubber with tested curing properties.
- 33.9.9 The semi conducting portion of the stress cone should be vulcanized with insulation so that both semi conducting and insulation portion becomes an integrated part.
- 33.9.10 The stress cone must be of proven design of stress control.
- 33.9.11 The moulding of rubber components should be aimed to achieve a smooth finish on interior and exterior of the components.
- 33.9.12 The stress cone should probably be reusable type.
- 33.9.13 In case of outdoor terminations, the suitable provision for covering the cable cores with reusable protective system from the crotch seal to the bottom of stress cone should be made.

33.10 Other Requirements

- 33.10.8 Proper stress control, stress grading and non tracking arrangement in the terminations shall be offered by means of proven methods, details of which shall be elaborated in the offer. Detailed sectional view of assemblies shall be submitted alongwith the offer.
- 33.10.9 The kits shall provide the total environment sealing, the details of which shall be offered alongwith the offer.
- 33.10.10 Provision for effective screening over each core be made and bidders shall categorically conform this aspect in their offer.
- 33.10.11 The material and components not specifically stated in the specification, but which are essential for satisfactory operation of the equipments shall be included without any extra cost.
- 33.10.12 The terminators shall be of better tracking resistant properties and fully reliable earthing system to maintain continuous contact with screening/armouring as the case may be.
- 33.10.13 The armour earthing arrangement shall form part of the termination.

- 33.10.14 Terminations shall have provision for shield connections and earthing.
- 33.10.15 The kits shall be suitable for storage without deterioration at a temperature upto 50 C for more than 5 years.
- 33.10.16 The fault level(as well as duration) withstand capability of terminations should be strictly matching with these parameters of cables for which the kits are intended to be used.
- 33.10.17 The words DHBVN/UHBVN alongwith trade name of manufacturer, month/year of manufacturer, size etc. shall be embossed / engraved or suitably marked with indelible ink/paint for the purpose of identification.
- 33.10.18 Suitable creepage extension/rain protection shield for outdoor termination shall be provided.
- 33.10.19 The adequate provisions for eliminating the chances of entrapment of air at the steps formed by semicon screen shall be made.
- 33.10.20 The gripping tubing (Termination boot) for the cable where trifurcation takes place, shall also be part of kit and covered under scope for this supply of this specification.
- 33.10.21 Name of sub-supplier for the raw material and standard according to which their raw material are tested, must be furnished alongwith the offer.
- 33.10.22 Detailed kit contents, whether manufactured by the bidder or bought from outside (with name of sub vendor) for each component must be indicated in the offer.
- 33.10.23 The terminations shall be supplied, in kit forms. All insulating and sealing materials, consumable items, conductor fittings, earthing arrangements and lugs etc. shall be included in the individual kit.
- 33.10.24 An Instruction manual in English, indicating the complete method/procedure to be adopted for installation of kits, preferably with more and more diagrams/pictorial presentation shall be supplied with each kit. Various items quantity thereof against each kit must be indicated in the instruction manual.

33.11 GUARANTEED TECHNICAL PARTICULARS

The terminations shall have same electrical and thermal characteristics as those of cables with which these are intended to be used. The tenderers must furnish the guaranteed technical particulars for each type/size of kit.

33.12 CONSUMABLES OR RE-USABLE PUSH ON TYPE KITS:

The details of consumable viz-a-viz reusable parts for each size of push on type (indoor /outdoor separately) termination must be supplied on a separate sheet. The %age of consumables for reusing these kits must be indicated for each size.

33.13 DRAWINGS

Complete detailed dimensional drawings showing all details of kit contents / bill of material for each size type.

Note : Any tender without complete guaranteed technical particulars and dimensional drawings shall be liable for rejection.

33.14 TRAINING:-

In case of placement of an order against this tender enquiry, the tenderer shall have to impart free of cost demonstration to selected number of Nigam personnel by installing few kits anywhere in Haryana, places of Purchaser's discretion. If required, supplier may have to give free of cost practical training regarding installation of their product in Nigam training institutes also

33.15 TESTS:

33.16 TYPE TESTS:

The termination kits of offered design should have been got tested from NABL accredited laboratory as per relevant standards with latest "Version."

33.17 Acceptance Tests:

Initially the following tests shall constitute as acceptance tests

- (i) Dimensional checking as per approved drawings
- (ii) Volume resistivity test: for various components
- (iii) AC High Voltage test after installation of terminations { as per IS: 13573/1992 or VDE- 0278) on appropriate cable.
- (iv) Dielectric strength of major components
- (v) D.C. High voltage test.
- (vi) Tracking resistance
- (vii) Ultimatic Elongation
- (viii) Tensile Strength.

The scope to include more type tests as acceptance tests shall be decided after processing the offers of various bidders/after knowing the details of testing facilities for type tests available with various tenderers.

IMPORTANT: The tenderers must specifically mention in their offer about the details of testing facilities for various type test as per IS;13573/1992 and or VDE-0278, available at their works, falling to do so, the offer is liable to be rejected on the presumption that adequate testing facilities are not available with them.

33.18 ROUTINE TESTS:- The following tests shall constitute routine test:

- (a) Dielectric Strength
- (b) Density
- (c) Heat Shock
- (d) Shrinkage ratio

The tenderer must specify the details of routine tests (being conducted at their works) alongwith the standard applicable, in their offer.

The routine test certificates shall be furnished alongwith the inspection call for each offered lot.

33.19 PACKING AND TRANSPORT:

The supplier shall be responsible for suitable packing of all the kits of material and marking on the consignment, so as to avoid any damage during transport and storage and to ensure correct dispatch to the destination.

34.1. TECHNICAL SPECIFICATION FOR 6.5/11

KV TR-XLPE POWER CABLES (ARMOURED)

FOR SIZES 1CX35, 50, 95, 120, 150, 185,300,

400 AND 500 MM2 AND 3CX35, 50, 95, 120, 150, 185, 300, 400 AND 500 MM2

34.2. SCOPE

The specification covers design, manufacturing, testing, packing, supply & delivery on FOR destination basis of 11 kV, single and three core, Water Tree Retardant (TR)- Cross linked Polyethylene (XLPE) insulated dry (gas) cured, PVC sheathed, Armoured power cables for effectively earthed systems.

34.3. STANDARDS:

Unless otherwise specified, the cable shall conform in all respects to IS 7098-Part -2

(2011), IS 8130- 1984 and IEC: 60502, IS 5831-1984, IS 10810-1984, IS 3975-1999 and IS 10418-1982 standards with latest amendments thereof.

34.4. CLIMATIC CONDITIONS:

1	Location	Haryana
2	Maximum ambient air temperature	50degC
3	Minimum ambient air temperature	(-)5degC
4	Average daily maximum ambient temperature	40degC
5	Max yearly weighted average ambient temperature	32degC
6	Lsoceraunic level	45days/year
7	Maximum altitude above mean sea level	1000meters
8	Minimum relative humidity	26%
9	Max. relative humidity	100%
10	Average no of rainy days/year	120
11	Basic Wind Speed	47m/s
12	Avg. Annual rainfall	900mm
13	Pollution	Moderate
14	Maximum wind pressure	195kg/msq
15	Sesimic Zone	Zone-IV,III,II

Note: Moderately hot & humid tropical climate is conducive to rust & fungus growth. The climatic conditions are also prone to wide variations in ambient conditions. Smoke is also present in the atmosphere. Heavy lightning also occurs during June to October.

34.5. PRINCIPAL PARAMETERS:

1.	Voltage grade (U _o / U)	6.35/11 kV
2.	Cores	3 Nos
3.	Nominal system voltage	11 kV
4.	Highest System voltage	12 kV
5.	System Frequency	50 Hz
6.	Variation in frequency	+/- 2.5%
7.	a. Maximum allowable temperature under continuous current condition	90 Deg C
	b. Maximum allowable temperature under short circuit condition	250 Deg C
8.	System earthing	Effectively earthed

34.6. DESIGN, CONSTRUCTION AND TECHNICAL PARAMETERS:-

34.6.1. CONDUCTOR:

The conductor of the cable shall be made from high conductivity, Electrolytic , H4 Grade, stranded aluminium to form compacted and circular shaped conductor having resistance within limits (as given in Appendix-2) as specified in IS 8130/ 1984 with latest amendments. The aluminium conductor shall be of class-2 as per IS 8130.

34.6.2. CONDUCTOR SCREEN/ SHIELD:

The conductor screen/ shield shall be an extruded layer of semi-conducting compound to confine the electrical field to the conductor. The allowable operating temperatures of the conductor shield shall be equal to or greater than those of the insulation. The conductor screen shall be extruded in the same operation in which the insulation is extruded. The semi-conducting screen polymer should be effectively cross linked to achieve 90 Deg C cable rating. The interface between the extruded conductor screen and insulation shall be free of any voids. The volume resistivity of the screen material shall not exceed 1000 ohm meter at 90 deg C. Note: Tapes are not acceptable.

34.6.3. INSULATION:.

The insulation shall be suitable for 11kV system voltage and the insulating material shall be cross linked Poly Ethylene (XLPE), cured by Dry curing process and applied by extrusion process as per IS 7098 and its latest amendments. The insulation shall be an extrusion of dry cured thermosetting cross linked poly ethylene, water tree retardant material rated for 90°C continuous operation. The bidder shall submit the description of dry/ gas curing process with the clear inclusion of equipments/ parameters involved.

The insulating material shall have excellent electrical properties with regard to resistivity, dielectric constant and loss factor and shall have high tensile strength and resistance to abrasion. This shall not deteriorate at elevated temperatures or when immersed in water. The insulation shall be preferably fire resistant and resistant to chemicals like acids, alkalis, oils and ozone.

The insulation properties shall be stable under thermal conditions arising out of continuous operation at conductor temperature of 90°C rising momentarily to 250°C under short circuit conditions. It shall be free from any foreign material or porosity visible to the unaided eye. The insulation shall be so applied that it fits closely on the conductor and it shall be possible to remove it without damaging the conductor.

The extruded water tree retardant (TR) XLPE insulation shall be of very high degree of purity. The manufacturer should provide the certification that the TR-XLPE compound used has proven track record, Manufacturer shall also submit Accelerated Water Tree Test (AWTT) & Accelerated Cable Life Test (ACLT) certificate also. The manufacturer shall maintain record of TR XLPE compound which may be verified by employer at any time during production. The tree retardant cross linked polyethylene insulation should be such as to retard the development and growth of water trees in the compound. The insulation compound shall be clean with low levels of contamination. The quality of insulation should be good and insulation should not be deteriorated when exposed to the climatic conditions.

The average thickness of insulation shall not be less than the nominal value as specified in IS: 7098 (Part II) with latest amendments. No tolerance on the negative side shall be acceptable.

Manufacturing process shall ensure that the insulation shall be free of voids. The insulation shall withstand mechanical and thermal stress under both steady state and transient operating conditions.

Eccentricity of insulation shall not exceed 15 percent as per annex-A of IS 7098(Part II)

34.6.4. INSULATION SCREEN/ SHIELD:

The insulation screen to be provided over the insulation shall be of Non-metallic , Semi- conducting polymer to confine the electrical field to the insulation. Over the semiconducting screen a metallic screening of copper tape shall be provided which shall be generally as per IS: 7098 (Part-H) with latest amendments . The semi conducting compound shall be suitable for the operating temperature of the cable and compatible with the insulating material.

The insulation screen shall be an extruded layer of semi-conducting compound and continuously covers the whole area of the insulation. The insulation screen shall be extruded in the same operation as the conductor screen and the insulation, called triple head extrusion. The semiconducting screens should be effectively cross linked to achieve 90°C cable rating. The contact surface between insulation and insulation screen shall be smooth and free from protrusion and irregularities. The interface between the insulation and insulation screen shall be free of any voids. Insulation screen shall be strippable type. The metallic screen shall consist of a layer of copper tape applied in helical form to be applied over the insulation screen.

34.6.5. WATER SWELLABLE TAPE:

Under the copper tape, water swellable tape of semiconducting material shall be provided on each core. The weight of the tape shall be 118 gms. Sq m. The swell height shall be ≥ 12 mm in 1 minute. The water swellable tape should be compatible to strippable/ non-strippable semi-conducting insulation screen over which it is applied.

34.6.6. CORE IDENTIFICATION (FOR THREE CORE CABLES ONLY):

Individual core of multi-core cables shall be colour coded and/or numbered for proper identification in accordance with clause 14.1 of IS: 7098 (Part - II)-2011.

34.6.7. FILLERS AND LAYING UP OF CORES (FOR THREE CORE CABLES ONLY):

In three core cables, the cores shall be laid together with a suitable right hand lay. The interstices shall be filled with non-hygroscopic material, Polypropylene. PVC fillers are not acceptable. Further, the compounds used with fillers shall be such as to have no deleterious effect on other components of the cable and to be stable at cable temperatures.

34.6.8. INNER SHEATH (COMMON COVERING):

The laid up cores shall be provided with inner sheath applied by extrusion process. It shall be ensured that the shape is as circular as possible. It shall be applied to fit closely on to the laid up cores and shall be possible to remove easily without causing any damage to the underlying insulated cores and screens.

The thickness of the inner sheath shall be as given in (Table 5, Clause 16.3), as per IS: 7098 (Part - II). No tolerance on the negative side shall be acceptable.

34.6.9. ARMORING:

The armour of cables shall consist of either galvanized round steel wires or galvanized formed wires as per clause 17.2 of IS: 7098 (Part 11).

The armouring shall be applied such that the minimum area of coverage shall be 90% and the gap between any two armour strips/ wire shall not be more than the width of strip/ diameter of armour wire. The galvanized steel strips shall comply with the requirements of IS: 3975-1988 with latest amendments. In case of Single core cable Non-magnetic aluminium armouring shall be used , exact details shall be finalized during detail engineering. The dimensions of the galvanized steel strip shall be as per IS: 7098 Part-II, (Table 6, Clause 17.3 Method (ii), Method (i) is not acceptable) 2011 with latest amendments. No tolerance on the negative side shall be acceptable.

34.6.10. BINDER TAPE:

Rubberised cotton tape should be provided over the armouring.

34.6.11. OUTER SHEATH:

The outer sheath shall consist of extruded tough outer sheath of PVC compound insulation over the armouring. The PVC compound for the outer sheath shall conform to type ST-2 of IS: 5831 - 1984 (amended up to date) with suitable additives (to prevent attacks by rodents and termites) shall be provided.

The color of the outer sheath shall be black. The cable must meet all the requirements of the IS: 7098 (Part 2)- 2011 amended up to date and shall bear ISI mark.

34.6.12. DISCHARGE FREE CONSTRUCTION:

The inner conductor shield, TR-XLPE insulation, and outer insulation shield shall be extruded with a true triple extruder head using a dry cure process. The conductor screen, Insulation and Insulation screen shall all be extruded in single point at one time process to ensure homogeneity and reduction of voids, in the insulation and the screening system of the cable. The bidders shall submit the manufacturing technique adopted by their manufacturers to achieve this motive.

The Nigam may will order the verification of true triple extrusion dry cure process at manufacturer's works as a pre qualification. During verification if it is found that the firm is not manufacturing the cable with true triple extrusion dry cure process the offer shall be rejected.

34.6.13. GENERAL:

All materials used in manufacturing of cable shall be new, unused and of finest quality. All materials should comply with the requirements I tests as per applicable IS I IEC specification, Indian Electricity Rules and any other statutory provision of rules & regulations.

The purchaser reserves the right to ask for documentary evidence of the purchase of various materials , (to be used for the manufacture of cable) as a part of quality control. Quality Assurance plan shall be submitted.

Each of cable type and size shall be ISI certified. The manufacturer shall submit self certified Xerox copy of valid ISI license with the offer.

34.6.14. CONTINUOUS CURRENT RATING:

As per Appendix -2

34.6.15. SHORT CIRCUIT CURRENT RATING:

As per Appendix -2

34.6.16. OPERATION:

- (i) Cable shall be suitable for operation under frequency variation of $\pm 3\%$ and voltage variation of +10% to -15% and combined frequency - voltage variation of 10% (absolute sum).
- (ii) Cable shall be suitable for laying in air, in duct or buried underground directly or through trench less boring.
- (iii) Cable shall have heat & moisture resistance properties. These shall be of type & design with proven record on distribution network service.

34.6.17. TESTS:

A. Type tests:

All the cable types (1C or 3C) and sizes i.e. items offered should have been fully type tested as per IS 7098 (Part-2)-2011 with amendments upto date at any NABL accredited Laboratory/ Test house. If the manufacturer's lab is accredited by NABL then it shall be acceptable for type testing. The bidder shall furnish one set of authenticated copy of type test reports along with the offer. These type tests must have been conducted within last five years prior to date of Bid opening. For any change between design/type of already type tested and the design I type offered against this specification, the purchaser reserves the right to demand repetition of type tests without any extra cost. For each type and size the type test shall be got carried out independently.

The purchaser also reserves the right to have tests carried out at his own cost from an independent agency, whenever there is a dispute regarding the quality of supply.

The type test certificates for type tests shall be furnished as Per IS 7098 (part-2)-2011 invariably with the offer

The first lot offered shall not be less than 10% of ordered quantity of each size of 11 kV XLPE ARMORED CABLE. One sample from the 1st Lot of 11 kV XLPE ARMORED Cable of each size as received in purchaser's store shall be selected and sealed by the inspecting officer nominated by purchaser's for getting it type tested at any NABL accredited testing laboratory. The charges incurred towards type test of the material received in our stores shall be borne by Supplier.

In case sample from first lot fails then :

- (a.) Supplier shall have to replace the full quantity of the respective inspected lot supplied to various stores and lying unused at stores.
- (b.) For the quantity already utilized against the order in field a deduction @ 15% (Fifteen Percent) of F.O.R. Destination prices of the material supplied shall be made .

(c.) Sample from next lot shall be selected again for type test. All test charges incurred towards type test of the material for second time shall be borne by the Supplier. In case sample again fails in the type test then further supplies shall not be accepted

(d.) Acceptance test:

The selection of sample pieces for acceptance test shall be as per Annexure D of IS 7098 (Part-II) 2011, of each lot offered for inspection or part thereof. The minimum shall be one drum.

The acceptance tests shall be carried as per IS: 7098 (Part-11) - 2011 out on the selected samples.

All the acceptance tests shall be carried out by the firm, in the presence of purchaser's representative at their works. The firm shall give atleast 15 days advance notice to the purchaser to enable him to depute the engineer for witnessing the tests. The test certificates for acceptance tests witnessed by inspecting officer/ engineer shall be submitted for approval before dispatch of material.

B. Routine Tests:

The following shall constitute the routine tests. The Inspector may also inspect the routine tests at the time of inspection as per Clause 20.7.2 of IS: 7098 (Part-11) - 2011.

34.6.18. QUALITY ASSURANCE PLAN:

A detailed list of bought out items which got into the manufacture of cables should be furnished indicating the name of the firms from whom these items are procured. The bidder shall enclose the quality assurance plan invariably along with offer followed by him in respect of the bought out items, items manufactured by him & raw materials in process as well as final inspection, packing & marking. The Company may at its option order the verification of these plans at manufacturer's works as a pr-qualification for technically accepting the bid

34.6.19. IDENTIFICATION MARK:

The outer sheath of the cable shall bear following identification parameters embossed at intervals of length of one meter of cable, throughout the cable:-

- (a) Name of manufacturer
- (b) Year of manufacture
- (c) Voltage grade
- (d) Size of cable
- (e) Cable code
- (f) Name of purchaser" DHBVN"
- (g) ISI certification mark.
- (h) Successive length

34.6.20. PACKING AND FORWARDING:

- (i) The cable shall be wound on non-returnable steel/wooden drums as per relevent IS: and packed in drums suitable for vertical I horizontal transport, as the case may be and shall be suitable to withstand rough handling during transport and outer storage. The outer surface of the drum shall be painted with white aluminium paint. Similarly, the inside surface of drum shall have the protective layer of varnish I paint.
- (ii) The wooden drums shall be reinforced with steel bends and strips for better protection.

- (iii) Length: For single and three core cables, the cable shall be supplied in standard drum length of 1000 meters +1- 5% tolerance for all the sizes of cable except for 300 mm² cable and above. The cable length for sizes 300 mm² and above shall be 500 meters +1- 5%. Overall tolerance in total quantity of ordered cables shall be +1- 2%.
- (iv) The ends of the cable shall be sealed by means of non-hygroscopic heat shrinkable type sealing material.
- (v) The following information be stenciled on the drum with either water proof ink or oil paint:
 - (a) Reference of IS I IEC standard.
 - (b) Manufacturer's name or trademark.
 - (c) Type of cable and voltage grade.
 - (d) No. of cores.
 - (e) Nominal cross-sectional area of conductor
 - (f) Cable code.
 - (g) Length of cable on the drum
 - (h) Gross weight
 - (i) Direction of rotation of drum (by means of an arrow)
 - (j) Position of outer end of cable
 - (k) Nigam's technical specification number.
 - (l) Year of manufacture
 - (m) Reference of Tender No./ P.O. No. date
 - (n) Property of " DHBVN ".
 - (o) Name of consignee and the destination.
 - (p) ISI Certification Mark

1. The firm shall be responsible for any damage to the cables during transit due to improper and inadequate packing. Wherever necessary, proper arrangement for lifting, such as lifting hooks, shall be provided. Any cable found short inside the packing cases shall be supplied by the supplier, without any extra cost.
2. Each consignment shall be accompanied by a detailed packing list, containing the following information:
 - (a.) Name of consignee
 - (b.) Details of consignment
 - (c.) Destination
 - (d.) Total weight of consignment
 - (e.) Handling and unpacking instruction
 - (f.) Bill of materials, indicating contents of each package.

34.6.21. INSPECTION:

- (i) The inspection may be carried out by the purchaser at any stage of manufacture. The successful bidder shall grant free access to the purchaser's representative at reasonable time, when the work is in progress. Inspection and acceptance, of any cables under this specification by the purchaser, shall not relieve the supplier of his obligation of supplying cable in accordance with

the specification and shall not prevent subsequent rejection, if the cables are not found as per the technical specifications.

- (ii) The supplier shall keep the purchaser informed in advance about the programme of manufacturing of cables so that arrangement can be made for inspection.
- (iii) The purchaser reserves the right to insist for witnessing the acceptance I routine tests of the bought out items.
- (iv) The manufacturer shall be responsible to pay penalty of Rs 20,000/- for each occasion at which the fake inspection call has been made or the material is rejected during testing/inspection by the authorized agency/representative of the Nigam. This penalty would be in addition to the expenses incurred by the Nigam in deputing the Inspecting Officer, carrying out such inspection.
- (v) At least S% of total numbers of drums subject to minimum of 2 in each lot put up for inspection shall be selected at random to ascertain the length/workmanship of cable by the following method:
- (vi) At the work of the manufacture, the cable shall be transferred from one drum to another for checking any manufacturing defects in the cable drum selected for conducting acceptance tests, at the same time measuring its length with the help of pulley & cyclometer graduated in presence of inspector. The difference in the measured length thus obtained from the declared length by the supplier in the packing list shall be applied to all the drums if the cable is found short during checking the sample lot (s).
- (vii) The supplier shall present the latest Calibration Certificate(s) of testing instruments/equipments to be used for the testing of the material covered in the Purchase Order to the authorized inspecting officer /inspecting agency of the purchaser. The testing instruments I meters /apparatus etc. should be got calibrated by the supplier from time to time from an independent testing laboratory I house having valid accreditation from National Accreditation Board for testing and calibrating laboratories for the testing equipment or from original manufacturers having traceability to NABL /NPL. The calibration certificate(s) should not in any case be older than one year at the time of presenting the same to the inspecting officer I inspecting agency of the purchaser. The testing instruments I equipment should be duly sealed by the Calibrating Agency and mention thereof shall be indicated in the calibration certificate(s).

34.6.22. DOCUMENTATION:

- (i) The bidder shall furnish following documents along with his offer- Sectional view, showing the General constructional feature with conductor I conductor screen I insulation I armoring I inner and outer sheath etc.
- (ii) Drawing of cable drums with details of material dimension and paint etc.
- (iii) All the required type test reports.
- (iv) Literature, pamphlets for the supplied items.

34.6.23. TECHNICAL AND GUARANTEED PARTICULARS:

The bidder shall furnish all Guaranteed Technical Particulars, as called for, in Appendix -3 of this Specification. Particulars, which are subject to guarantee, shall be clearly identified. Offer not containing these information will not be considered for acceptance.

34.6.24. CHALLENGE CLAUSE:-

The material offered/received after the inspection by the authorized inspecting officer may again be subjected to test for any parameter from any testing house/in-house technique of the Nigam & the results if found deviating/ un-acceptable or not complying to Technical specification, the bidder shall arrange to supply the replacement within thirty (30) days of such detection at his cost including to & fro transportation. In addition, penalty @ 10% of cost of the inspected lot of material shall be imposed.

34.6.25. WARRANTY PERIOD:-

The supplier shall be responsible to replace, free of cost, with no transportation or insurance cost to the purchaser, up to destination, the whole or any part to the material which in normal and proper use proved as defective in quality or workmanship, subject to the condition that the defect is noticed within 72 months from the date of commissioning. The consignee or any other officer of Nigam actually using the material will give prompt notice of each such defect to the supplier. The replacement shall be effected by the supplier within a reasonable time, but not, in any case, exceeding 45 days/ The supplier shall, also, arrange to remove the defective material within a reasonable period, but not exceeding 45 days from the date of issue of notice in respect thereof, failing which, the purchaser reserve the right to dispose of defective material in any manner considered fit by him (purchaser), at the sole risk and cost of the supplier. Any sale proceeds of the defective material after meeting the expenses incurred on its custody, disposal handling etc., shall however be credited to the supplier 's account and set off against any outstanding dues of the purchaser against the supplier. The warranty shall be for the entire duration of the warranty period.

34.6.26. NIGAM'S QUALITY ASSURANCE PLAN:-

The Nigam's Quality assurance plan for the inspection of material at manufacturer's factory, post receipt inspection at Nigam's stores/ turnkey contractor's site stores , dispatch of material, supply lots, counter checking etc is in force for the procurement and turnkey works which shall be applicable, as the case may be, alongwith upto date amendments, if any.

5. APPENDIX-2

1. Continuous current rating-

Nominal cross sectional area of conductor (sq mm)	Continuous current rating for Three core cables{Amps}		Continuous current rating for single core cables(amps)	
	In ground	In air	In ground	In air
35	115	125	115	140
50	130	150	140	170
95	190	230	200	255
120	220	260	230	295
150	245	295	255	335
185	275	335	290	385
300	355	450	375	520
400	400	520	425	610
500	455	600	485	720

Depth of laying: 900 mm; Ambient Air temp: 40 deg C; Ground Temp: 30 deg C; Thermal resistivity of soil: 150 deg C cm/w.

2. Conductor resistance and Short Circuit Current Carrying Capacity (common for 1C and 3C)-

Nominal area of conductor(sqmm)	Maximum DC resistance at 20deg C{Ohms/km}	Short Circuit current for conductor(KA/sec)
35	0.8680	3.29
50	0.6410	4.70
95	0.3200	8.93
120	0.2530	11.28
150	0.2060	14.10
185	0.1640	17.39
300	0.1000	28.20
400	0.0778	37.60
500	0.0605	47.00

6. APPENDIX-3

SCHEDULE OF GUARANTEED TECHNICAL PARTICULARS FOR 11KV XLPE POWER CABLE

Sl. No.	Particulars	Unit	Quoted Value
1	Manufacturer's name and address		
2	Location of Factory_		
3	Standard to which cable conforms		
4	Conductor Details a. Material compositions class as per IS:8130 b. Shape of stranded conductor c. Number of strands in each core (Min) d. Diameter of each strand e. Nominal cross section area of each core f. Guaranteed weight of aluminium per Core per Km (min)	No. mm sq. mm. kg/km mm. sq.mm kg/km	
5 .	Conductor Screen Material Thickness (min)	mm mm	
6 .	Insulation Material with ref. of ISS Thickness of insulation (mm) (min)	mm mm	
7.	Insulation Screen Material Semi Conducting Part Metallic Part Thickness for Semi conducting part (min) Metallic part (min)	mm mm mm mm	
8.	INNER SHEATH Material Thickness (min)	mm mm	
9.	Filler material		
10.	ARMOURING Material Dimension of Flat armouring strip/wire	mm xmm	
11	OUTER SHEATH Material Thickness of sheath_(min)	mm	
12.	Weight of Finished cable (approx)	kg/km	
13	Standard delivery length per drum	m	
14	Tolerance in standard drum length of the cable	%	
15	Gross weight of drum including cable (approx)	kg	
16	Recommended depth of laying	mm	
17	Short circuit withstand current for 1sec.	kA	
18	Voltage drop per thousand m length at rated current When laid directly in ground When laid directly in covered trench When laid directly in air	volt/km volt/km volt/km	
19	Impulse voltage withstand	kV	
20	Derating factors under various conditions of installation a) D.C resistance per core at 20uC (Max.)	ohm/km ohm/km micro F/km M-ohm/km ohm/km	

Sl. No.	Particulars	Unit	Quoted Value
21	b) AC impedance per core at 20vC (Max.) AC Reactance per core at 20oC (Max.) Capacitance per core Insulation resistance at 27 C (Min) f) Volume resistivity of insulation at 27oC (Min)		
22	Maximum partial discharge magnitude at 1.5 U _o	pC	
23	Maximum cable charging current at normal operating voltage	amp/km	
24	Recommended minimum bending radius	mm	
25	Name of manufacturers of bought out raw material Aluminium PVC compound XLPE compound Galvanized steel strip for armouring Any other		
26	Whether same cable has been type tested? If yes, when and where it was tested It is expected that you will enclose an authenticated electro state copy of type test of same design, size and type of cable. Please inform whether or not you have enclosed the same. If yes, how main sheets does it contain.	Yes/No Yes/No Nos.	
27	Whether wood preservative shall be applied to whole drum?	Yes/ No	
28	If yes, Details in brief Whether all ferrous parts shall be treated with rust preventive finish or coating? If yes, details in brief.	Yes/ No	
29	Whether water proof paper layer shall be applied to the surface of drum and over the outer cable layer?	Yes I No	
30	Reference of license in use of ISI and other certification marks, if any		

35.1. TECHNICAL SPECIFICATION

OF LAYING & INSTALLATION

OF 33 KV, 11 KV AND

LT UNDERGROUND CABLES.

The laying of the cable shall be carried out in accordance with the IS 1255 (1983):Code of practice for installation and maintenance of power cables up to and including 33 kV rating, with latest amendments, and IS 3043 –Code of Practice for earthing, with latest amendments, and Nigam’s latest instructions

The cable installations should be carried out to meet the requirements of the Indian Electricity Rules 2005 with latest amendments, Indian Electricity Act 2003, with latest amendments, and other regulations in force and necessary checks or tests should be carried out prior to commissioning for compliance with such rules and regulations. It is also necessary to consult the local authorities such as HUDA/ MCG, other public utilities responsible for roads, railways, telecommunications, sewerage, gas and water supply besides other private developers responsible for maintenance in their areas. The cable installations should be carried out by competent and authorized persons only.

35.2.Selection of route:-

While selecting the route the following guideline may be kept in view:-

- (a.) The route should be away from parallel running gas, water pipes & telephone/telecommunication cables etc as far as possible.
- (b.) The route should be selected in such a manner that involves minimum obstacles such as roadway crossing, railway crossing etc.
- (c.) If possible the cable should be laid along the footpath rather than the carriage way.
- (d.) The cable route should not involve sharp bends.

35.3.Methods of cable laying:-

- (a.) Laying direct in the Ground: - The cables shall be laid direct in the ground after manual digging, under proper protective covers.
- (b.) Laying In Pipes: - At railway crossing, road crossing etc the cable should be laid primarily through trenchless boring and in HDPE pipes. In some circumstances, the laying of cable direct in ground for road crossing may be allowed for which the contractor has to seek the approval of the respective civic authorities and pay any charges thereof, which shall not be reimbursed by Nigam. No extension of time in case of delay due to this account will be allowed.
- (c.) Laying on Racks: - Inside the buildings, Industrial plants, S/Stns. & tunnels, cables may be laid on racks fixed to the wall or supported from the ceilings, with the approval of Engineer in charge.
- (d.) Laying in Trench: - In exceptional circumstances, In an inhabited area & highly protective area like airport, grid S/Stn. switch yard, Hospital, School & other military installation, the cable may be laid in covered trenches, with the approval of Engineer in charge.

35.4.Installation Procedure:-

- (a.) While laying direct in the ground, the cable should be laid on a bedding of minimum 75 mm riddled soil or sand & covering it with additional riddled soil or sand of minimum 75 mm & Protecting it by means of RCC slabs, as per the drawing provided in the tender documents.
- (b.) The minimum depth of laying from the ground surface to the top of the cable is as follows, however the drawings enclosed in this regard shall be followed:-
 - (i) KV cable – 0.9 meter
 - (ii) 33 KV Cable – 1.05 meter
 - (iii) LT Cable and control cables – 0.75 meter
 - (iv) Cables at road crossings – 1.00 meter
 - (v) Cables at railway level crossings (measured from the bottom of sleepers to the top of pipe) – 1.00 meter

The depth may vary as per the site conditions for which the contractor will seek approval from the Engineer in charge.

- (c.) The minimum clearance are as follows:-
 - (i) Power cable to control cable – 0.2 meter.
 - (ii) Power cable to communication cable – 0.3 meter.
 - (iii) Power cable to Gas/Water main – 0.3 meter
 - (iv) Power Cable to Power cable – clearance not necessary, however, larger the clearance better would be current carrying capacity.
- (d.) The diameter of the cable conduit or pipe or duct shall be at least 1.5 times the outer diameter of the cable. Spare ducts for future extensions should be provided. The spare duct runs should be sealed off.
- (e.) For identification of the route of U/G cable and safety of others/human being the word “Power cable” should be marked on the protective covering of RCC slabs, as per the drawings enclosed.
- (f.) All the other materials like coarse and fine aggregate sand, joint markers, sealing, identification strips/ tags of metal or plastics, route markers, cable support clamps, terminals and inline connectors, sealing compounds etc., whether specifically mentioned or not in these specifications are deemed to have been included in the scope of supply and installation. These shall have to be got approved by the contractor from the Engineer in charge before use. Similarly, the contractor has to arrange for all the tools and plants and machinery required for the works at his own cost.
- (g.) Identification strips/ tags of metal or plastics should be attached to the cables, particularly if several are laid in parallel, 8 to 10 m apart. Identification tags should also be attached at every entry point into the buildings and at the cable end terminations.
- (h.) A bedding of riddled earth or river sand should be provided and protective cable warning tapes should be used. Instruction to back fill the trench should not be given until the entire length is protected by cable cover and checked.
- (i.) The precautions to be taken while laying in ducts by taking care against abrasions during pulling; proper alignment of duct; precautions against damage to cable at duct entry positions etc.

35.5. Earthing and bonding:

The metal sheath, metal screen (if any) and armour of any cable should be efficiently earthed at both ends in accordance with IS 3043 with latest amendments.

35.5.1. Testing:

The testing and electrical measurements of cable installations shall be carried out at various stages of laying/ installations as given in IS 1255 with latest amendments. The test of the completed installation may be measured and entered into record book for comparison purposes during service life of cable installation and during fault location.

35.5.2. Cable installation plan :

Cable installation plan should be prepared in accordance with the clause 15 of IS 1255 which should contain the details of installation such as –type of cables, cross section area, rated voltage, cable number and drum number; year and month of laying; actual length between joint-to-joint or ends; location of cables and joints in relation to certain fixed reference points; date of making the joint; results of original electrical measurements and testing on cable installation.

35.5.3. Work area fencing:

The work of laying the underground cable require a lot of digging along the roadside pavements, therefore it is mandatory that the dug up work area is temporarily fenced with proper warning indications for day time and also for night time with lighting for the safety and convenience of the people moving around the work area.

35.5.4. Watch and ward and safety:

The dug up trenches/ pits may prove hazards to the public if left unguarded, therefore, it is mandatory that the contractor will ensure that all the dug up areas are guarded 24X7 for the safety of the public. Any mishap to anything or anybody due to the negligency of the contractor on this aspect shall be to the contractor's account.

35.5.5. Miscellaneous:

- (i) All unpainted /Un-galvanized iron sections like Channel, Angle/Clamps Stay sets etc. shall be given 2 coating of Red Oxide before installation to prevent rusting. To avoid rusting anti-corrosion aluminium paint shall also be provided. The steel items shown in the BOQ are in MT therefore the manufacture of the steel items shall be done only after getting the drawings approved.
- (ii) One set of 11 KV lightning arrestor shall be provided within 3 KM area,.
- (iii) The proposed 11 kV power lines may run parallel for certain distance with the existing power lines, which may remain energized during the laying period. As a result there is a possibility of dangerous voltage build up due to electromagnetic and electrostatic coupling in the pulling wire, conductors and earth wires which although comparatively small during normal operations can be severe during switching. It shall be Contractor's responsibility to take adequate safety precautions to protect his employees and others from this potential danger.
- (iv) The Contractor shall inform the Engineer whenever he wants to avail the 'Permit to Work' from the local sub-division for erecting the new 11 kV line or augmenting the existing 11 kV line. A minimum 48 hours advance notice in writing for availing the shutdown on any live 11 kV feeder/LT lines shall be given to the Engineer. The 11 kV/ LT line on which permit is taken should be made clear from all the temporary earth, men and material before cancellation of the 'Permit to Work'. It is worth mentioning here that the 'Permit to Work' on existing line shall be arranged through the Engineer or his representative and the same shall also be got cancelled through the same agency only. No

‘Permit to Work’ shall be issued on any line directly to Contractor or his staff from any 33 kV or 66 kV Sub-Station.



1. Necessary consent shall be obtained from the concerned authorities while laying U/G cable across railway, roads and water-pipe lines.

Final Checking, Testing and Commissioning:

After completion of Works, final checking of lines shall be done by the Contractor to ensure that all the Foundation Works, equipment erection and cable laying etc has been done according to specifications and as approved by the Employer. All the Works shall be thoroughly inspected keeping in view the following main points.

- a. The earth filling of the dug out cable trenches has been properly done with adequate compacting.
- b. The restoration of the dug out roads, streets, ramps etc have been properly carried out into the original condition.
- c. All the cable out points from the ground have been properly secured by way of using clamps/ cleats/ fasteners/ or any other suitable installation etc, after getting the design approved.
- d. All the RCC markers have been properly planted with desired inscription.
- e. The insulation of line as a whole is tested by the Contractor by providing his own equipment, labour etc. to the satisfaction of Employer.
- f. All the electrical equipments have been properly earthed to the satisfaction of employer.
- g. All conductor and earth wire accessories are properly installed.
- h. All other requirement to complete Work like fixing of danger plate, phase plate, number-plate, anti-climbing device (if applicable) etc. are properly installed.
- i. The lines are tested satisfactorily, for inspection, by the Chief Electrical Inspector, Haryana, before commissioning.

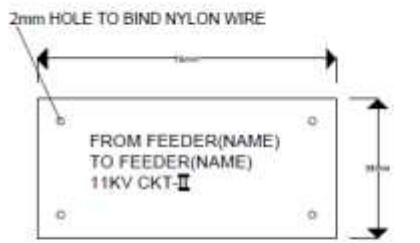
Annexure E5 nos. drawings

<p>NOTE:- MATERIAL-ALUMINIUM THICKNESS-2mm</p> <p>SIZE OF LETTER-5mm</p>  <p>75mm</p> <p>38mm</p> <p>FROM FEEDER(NAME) TO FEEDER(NAME) 11KV CKT-I</p> <p>2mm HOLE TO BIND NYLON WIRE</p>  <p>75mm</p> <p>38mm</p> <p>FROM FEEDER(NAME) TO FEEDER(NAME) 11KV CKT-I</p>  <p>ERECTION DIAGRAM</p>	<p>LEGEND:-</p> <p>NOTE:-</p> <ol style="list-style-type: none"> 1) ALL DIMENSIONS ARE IN mm. 2) ALL LETTER SHALL BE ENGRAVED AND PAINTED WITH ACRYLIC EXTERIOR GRADE PAINT IN BLACK COLOUR. 3) THE TAG SHALL BE TIED WITH THE CABLE USING 1 sqmm nylon wire. 4) IDENTIFICATION TAG TO BE PUT ON ALONG THE CABLE @ 2.5m DISTANCE AT ALTERNATE LOCATIONS AS SHOWN IN <p>DHBVN SMART CITY CIRCLE, GURGAON</p> <p>PROJECT:- SMART CITY PROJECT (PHASE-1), GURGAON MISCELLANEOUS</p> <p>TITLE:- IDENTIFICATION TAG 11KV POWER CABLE</p>
---	---

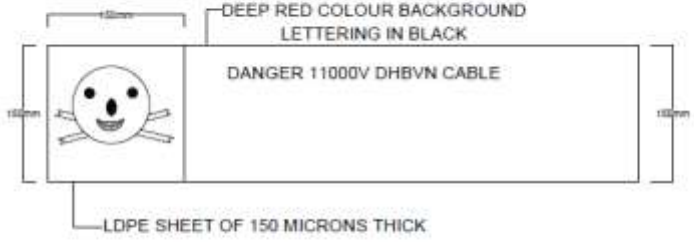
 <p>DEEP RED COLOUR BACKGROUND LETTERING IN BLACK</p> <p>DANGER 11000V DHBVN CABLE</p> <p>LDPE SHEET OF 150 MICRONS THICK</p>	<p>LEGEND:-</p>
	<p>NOTE:- 1) ALL DIMENSIONS ARE IN mm.</p>
	<p>DHBVN SMART CITY CIRCLE, GURGAON</p>
	<p>PROJECT:- SMART CITY PROJECT (PHASE-1), GURGA</p>
	<p>TITLE:- WARNING TAPE FOR 11KV CABLE LAYING</p>

10/08/20

NOTE:-

- 1) RE-INFORCED USING 6mm MS ROD. USING 20mm BROKEN STONE 1:2:4 M20 CONCRETE
- 2) LETTERS TO BE ETCHED
- 3) ALL DIMENSIONS ARE IN MILLIMETERS UNLESS SPECIFIED
- 4) REINFORCEMENT STEEL SHALL CONFORM TO IS: 432 (PART-1) OR IS: 1786
- 5) ALL LETTERS SHALL BE ENGRAVED WITH HEIGHT AND WIDTH AS SHOWN IN THE DRAWING WITH 4mm DEPTH

REFERENCE:

1. IS 5820 : 1979 SPECIFICATION FOR PRECAST CONCRETE CABLE COVER

DHBVN

SMART CITY CIRCLE, GURGAON

PROJECT:

SMART CITY PROJECT (PHASE I), GURGAON

ITEM:

CABLE PROTECTION SLAB

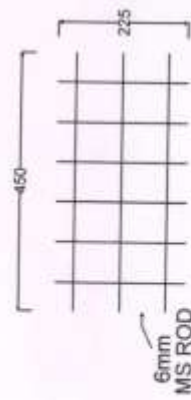
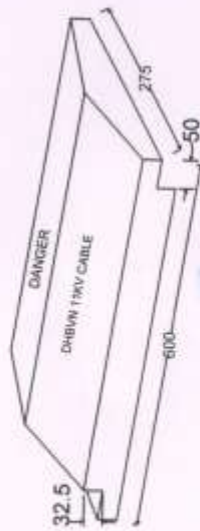

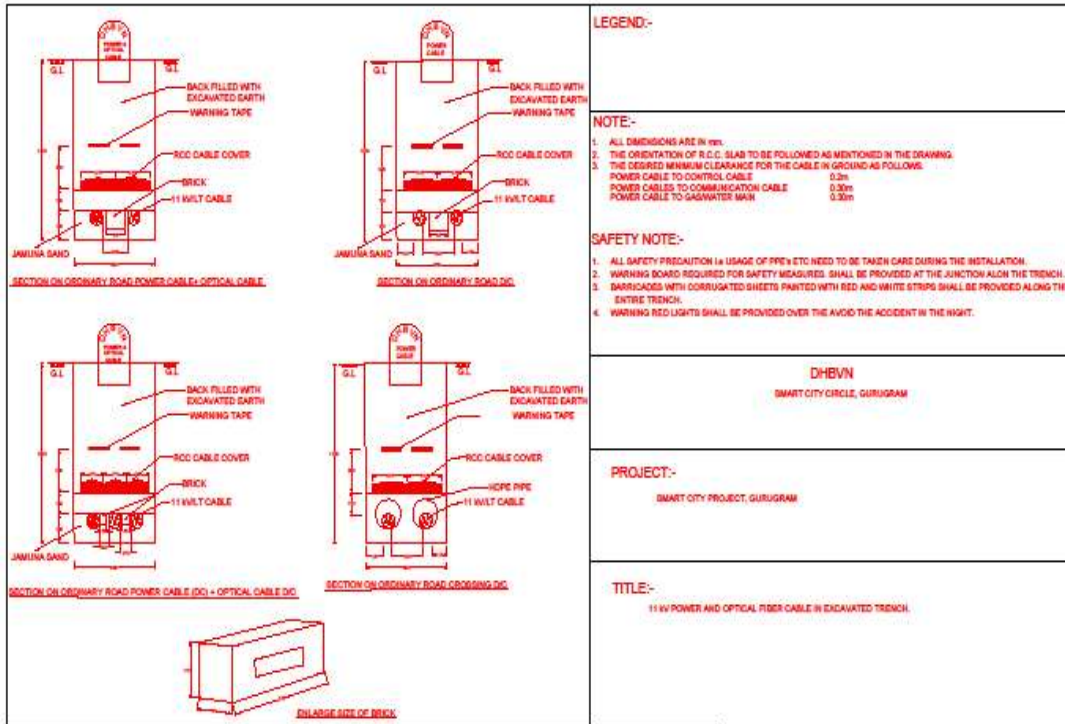

36.1. SPECIFICATION OF CABLE CONTAINMENTS

36.2. Cable Trays:

(A) Trays for Power Cables:

- (i) Ladder type cable trays shall be used for power cables. Material of construction shall be of hot dip GI.
- (ii) Minimum thickness of all ladder type cable trays shall be 2 mm for trays for width of 450 and 600mm and not less than 2.5mm for trays for 300mm.
- (iii) Height of all power cable trays shall be minimum 75mm. Height of the tray shall be decided on maximum overall diameter of cable laid on particular tray.

(B) Cable trays and supports including coupler plates shall be in accordance with IEC 61537 and shall be of Hot dip GI.

(C) Cable tray supports shall provide adequate strength with minimum rigid support to the fully laden cable tray along its entire length.

36.3. Installation on Cable Trays:

(A) Wherever possible, cable trays shall be installed in full lengths without cutting. Should it be necessary to cut or drill a length or tray, the bared ends shall be dressed.

(B) All cables shall be firmly secured to the tray using purpose made saddles, as approved by the Engineer, together with cable cleats recommended by the cable manufacturer.

(C) Installation on ladder racks:

- (i) Ladder racking shall be constructed from Hot dip Galvanized, secured to walls or ceilings by proper channels, cast into the structure or directly in concrete wall.
- (ii) Wherever ladder sections are cut and shaped on site, cut edges shall be dressed.

36.4. Conduit and Fittings:

(A) Conduits:

- (i) Metallic Conduit:

All outdoor black stove conduits shall be of rigid galvanized steel, unless otherwise specified. All metallic conduits shall be as per IS 9537 (Part II)

- (ii) Non-Metallic Conduit:

- (a) All exposed indoor conduits, underground, concealed or concrete embedded conduits shall be uPVC unless otherwise specified on drawing. Conduits in classified areas shall be uPVC.
- (b) Conduits shall be of a circular cross section of appropriate mechanical strength. Indoor conduits may have a lesser strength than those for outdoor and buried applications.
- (c) Conduits shall be durable and impact resistant as per IS 9537 and IS 14927.
- (d) Conduits shall be fire retardant and corrosion resistant as per IS 9537.
- (e) Conduits shall have negligible water absorption.

36.5. HDPE Pipes

(A) Refer specification of 'HDPE Pipe'.

37.1. TECHNICAL SPECIFICATION FOR HDPE Pipes of 125 mm, 160 mm and 200 mm DIA

37.2. SCOPE

This specification covers technical requirements of design, Constructional features, Inspection, testing , Supply & transportation of HDPE pipe of 125 mm, 160 mm & 200 mm diameter at DHBVN stores/site.

37.3. APPLICABLE STANDARDS:

The equipment covered by this specification shall unless otherwise stated, be designed, manufactured and tested in accordance with the latest editions of the following Indian, International Standards and shall conform to the regulations of the local Statutory authorities:

- (a) IS 4984-1995: Specification for High Density Polyethylene Pipe with latest amendment.

37.4. CLIMATIC CONDITIONS OF THE INSTALLATION:

Max. Ambient Temperature	50 deg C
Max. Daily average ambient temp	40 deg C
Min. Ambient Temperature	0 deg C
Maximum Humidity	100%
Minimum Humidity	10%
Average No of thunderstorm per annum	40
Average Annual Rainfall	750 mm
Average No. of rainy days per annum	50
Rainy months	June to Oct
Altitude not exceeding	300 meters
Wind Pressure	195 kg/sq m up an elevation of 30 m

Atmosphere is generally laden with mild acid and dust suspended during dry months and subjected to fog in cold months. The design of the equipment and accessories shall be suitable to withstand seismic forces corresponding to an acceleration of 0.1 g

37.5. GENERAL TECHNICAL REQUIREMENTS

A) FOR HDPE PIPE 160 MM DIA

Sl.No	Item Description	Unit	Requirement
1	M.F.R. (190 °c, 5 KG load)	Gm/10 mins	0.20 to 1.10
2	Specified base density	Kg/mt3	940 to 958
3	Material Grade		PE-63
4	Wall Thickness	Mm	7.7 – 8.7
5	Carbon Black	%	2.5 ±0.5
6	Antioxidant	% by mass	< 0.3% by mass
7	Overall Migration	Mg/dm2	10 Max
8	Reversion	%	<=3%

Sl.No	Item Description	Unit	Requirement
9	Hydraulic Characteristics		No sign of localized swelling, leakage or weeping (at 80°C for 48 & 165 hrs)
10	Continuous Temperature withstand capacity	°C	120

B) FOR HDPE PIPE 63 MM DIA

Sl.No	Item Description	Unit	Requirement
1	M.F.R. (190°C, 5 kg load)	Gm/10 mins	0.20 to 1.10
2	Specified base density	Kg/mtr3	940 to 958
3	Material Grade		PE – 63
4	Wall Thickness	mm	4.4 – 5.1
5	Carbon Black	%	2.5 ±0.5
6	Antioxidant	% by mass	< 0.3% by mass
7	Overall Migration	MG/dm2	10 Max
8	Reversion	%	<=3%
9	Hydraulic Characteristics		No sign of localized swelling, leakage or weeping (at 80°C for 48 & 165 hrs)
10	Continuous Temperature withstand capacity	°C	110

C) FOR HDPE PIPE 125 MM DIA

Sl.No	Item Description	Unit	Requirement
1	M.F.R. (190°C, 5 kg load)	Gm/10 mins	0.20 to 1.10
2	Specified base density	Kg/mtr3	940 to 958
3	Material Grade		PE – 80
4	Wall Thickness	mm	4.9 – 5.6
5	Carbon Black	%	2.5 ±0.5
6	Antioxidant	% by mass	< 0.3% by mass
7	Overall Migration	MG/dm2	10 Max
8	Reversion	%	<=3%
9	Hydraulic Characteristics		No sign of localized swelling, leakage or weeping (at 80°C for 48 & 165 hrs)
10	Continuous Temperature withstand capacity	°C	110

D) For HDPE PIPE 200 MM DIA

Sl.No	Item Description	Unit	Requirement	
			PN4	PN6
1.	M.F.R. (190°C, 5 kg load)	Gm/10 mins	0.20 to 1.10	0.20 to 1.10
2	Specified base density	Kg/mt3	940 to 958	940 to 958
3.	Material Grade		PE-63	PE-63
4.	Wall Thickness	Mm	9.6-10.8	14-15.6

Sl.No	Item Description	Unit	Requirement	
			PN4	PN6
5.	Carbon Black	%	2.5 ±0.5	2.5 ±0.5
6.	Antioxidant	% by mass	<0.3 % by mass	<0.3% by mass
7.	Overall Migration	Mg/dm ³	10 Max	10 Max
8.	Reversion	%	<=3%	<=3%
9.	Hydraulic Characteristics		No sign of localized swelling, leakage or weeping (at 80 °C for 48 & 165 hrs)	No sign of localized swelling, leakage or weeping (at 80 °C for 48 & 165 hrs)
10	Continuous Temperature withstand capacity	°C	110	110

37.6. GENERAL CONSTRUCTIONS FOR HDPE PIPE

High –density polyethylene (HDPE) is apolyethylenethermoplastic made from petroleum. Known for its large strength to density ratio, HDPE is commonly used in the production of corrosion-resistant piping. The HDPE pipes required in size 125mm dia of material grade PE-80 and pressure rating is PN4, in size 160 mm dia of material grade PE-63 and pressure rating is PN4 and in size 200 mm dia of material grade PE-63 and pressure rating is PN 4 & PN 6. The HDPE pipe material should be Fire Retardant or non-Flammable. All HDPE pipe Color should be Black.

37.7. MARKING

The body of the device shall be appropriately embossed/marked with “PROPERTY OF DHBVN” such that it is permanent and does not harm the body of the device.

37.8. TESTS

All routine, acceptance type tests shall be carried out in accordance with the relevant IS. All Routine/acceptance tests shall be witnessed by the purchaser/his authorized representative.

TYPE TEST:

The following tests shall constitute the type tests and shall be carried out as per relevant IS: 4984-1995 with latest Amendment.

- (a) Avg. Outer Diameter
- (b) Wall thickness
- (c) Measurement of Quality
- (d) Heat Reversion
- (e) M.F.R. at 190 Degree C
- (f) Carbon Black Content
- (g) Carbon Dispersion
- (h) Density at 27 Degree C
- (i) Overall Migration
- (j) Hydraulic Characteristics

ROUTINE/ACCEPTANCE TEST:

The following tests shall be got conducted in presence of purchaser representative as per relevant IS: 4984-1995 with latest Amendment on the samples taken from the offered lot material for the purpose of acceptance of that lot of material.

- (a) Avg. Outer Diameter
- (b) Wall thickness
- (c) Measurement of Quality
- (d) Heat Reversion
- (e) M.F.R. at 190 Degree C
- (f) Carbon Black Content
- (g) Carbon Dispersion
- (h) Density at 27 Degree C
- (i) Overall Migration
- (j) Hydraulic Characteristics

37.9. TYPE TEST CERTIFICATES

The bidder shall furnish the type test certificates of the individual component for the tests as mentioned as above as per the corresponding standards, if asked for by DHBVN. All the tests shall be conducted by NABL accredited Lab as per the relevant standards. Type test should have been conducted in certified Test Laboratories during the period not exceeding 5 years from the date of opening the bid. In the event of any discrepancy in the test reports i.e. any test report not acceptable or any/all type tests (including additional type tests, if any) not carried out, same shall be carried out without any cost implication to DHBVN.

37.10. PRE DISPATCH INSPECTION:

The Material shall be subject to inspection by a duly authorized representative of the DHBVN. Inspection may be made at any stage of manufacture at the discretion of the purchaser and the equipment, if found unsatisfactory as to workmanship or material, the same is liable to rejection. Bidder shall grant free access to the places of manufacture to DHBVN's representative at all times when the work is in progress. Inspection by the DHBVM or its authorized representatives shall not relieve the bidder of his obligation of furnishing equipment in accordance with the specifications. Material shall be dispatched after specific MDCC (Material Dispatch Clearance Certificate) is issued by DHBVN.

Following documents shall be sent along with material.

- (a.) Test reports
- (b.) MDCC issued by DHBVN
- (c.) DHBVN Invoice in duplicate
- (d.) Packing list
- (e.) Drawings & catalogue
- (f.) Guarantee/Warranty card
- (g.) Delivery Challan
- (h.) Other Documents (as applicable).

37.11. INSPECTION AFTER RECEIPT AT STORES

The material received at DHBVN store will be inspected for acceptance and shall be liable for rejection, if found different from the reports of the pre-dispatch inspection and one copy of the report shall be sent to each MM & PD department.

37.12. GUARANTEE

Bidder shall stand guarantee towards design, materials, workmanship & quality of process/manufacturing of items under this contract for due and intended performance of the same, as an integrated product delivered under this contract. In the event any defect is found by the Purchaser up to a period of 12 months from the date of commissioning or 18 months from the date of last supplies made under the contract whichever is earlier. Bidder shall be liable to undertake to replace/rectify such defects at its own costs within mutually agreed time frame, and to the entire satisfaction of the Purchaser, failing which the Purchaser will be at liberty to get it replaced/rectified at Bidder's risks and costs and recover all such expenses plus the Purchaser's own charges (@ 20% of expenses incurred), from the Bidder or from the "Security cum Performance Deposit" as the case may be.

Bidder shall further be responsible for "free replacement" for another period of THREE years from the end of the guarantee period of any "Latent Defects" if noticed and reported by the Purchaser.

37.13. PACKING

Bidder shall ensure that all the equipment covered under this specification shall be prepared for rail/road transport in a manner so as to protect the equipment from damage in transit.

37.14. TENDER SAMPLE

37.15. QUALITY CONTROL

The bidder shall have a prove track of not less than 10 years in HDPE Pipe manufacturing and servicing in Indian market. The bidder shall submit with the offer Quality assurance plan indicating the various stages of inspection, the tests and checks which will be carried out on the material of construction, components during manufacture. AS part of the plan, a schedule for stage and final inspection within the parameters of the delivery schedule shall be furnished. The Purchaser's engineer or its nominated representative shall have free access to the manufacturer's /sub-supplier works to carry out inspections.

37.16. MINIMUM TESTING FACILITIES

Bidder shall have adequate in house testing facilities for carrying out all routine tests & acceptance tests as per relevant Indian standards.

37.17. MANUFACTURING ACTIVITIES

The successful bidder will have to submit the bar chart for various manufacturing activities clearly elaborating each stage with quantity. This bar chart should be in line with the Quality assurance plan submitted with the offer. This bar chart will have to be submitted within 15 days from the release of the order.

37.18. SPARES, ACCESSORIES AND TOOLS

Not applicable

37.19. DRAWINGS AND DOCUMENTS

Following documents shall be prepared based on DHBVN specifications and statutory requirements with complete BOM and shall be submitted with the bid:

- a) Completely filled in Technical Particulars
- b) General description of the equipment and all components including brochures.
- c) Bill of Material
- d) Type of Test Certificates
- e) Experience List.

After the after of the contract four (4) copies of the drawings, drawn to scale, describing the equipment in detail shall be forwarded for approval and shall subsequently provide four (4) complete sets of final drawings, one of which shall be auto positive suitable for reproduction, before the dispatch of the equipment. Soft copy (compact Disk CD) of all the drawing, GTP, test certificates shall be submitted after the final approval of the same to the purchaser.

Following Drawings/Documents shall be submitted after the award of the contract:

S.No	Description	For Approval	For Review Information	Final Submission
1	Technical Parameters			
2	Manual/Catalogues/drawings for all components			
3	Technical details and test certificates of the component			
4	Instructions for use			
5	Transport/shipping dimension drawing			
6	QA & QC Plan			
7	Routine Acceptance and Type test Certificates			

Instruction Manuals : Bidder shall furnish two (2) soft copies (CD) and four (4) hard copies of nicely bound manual (in English Language) covering erection and maintenance instructions and all relevant information pertaining to the main equipment as well as auxiliary device.

37.20. GUARANTEED TECHNICAL PARTICULARS

A) FOR HDPE PIPE 160 MM DIA

Sl.No	Item Description	Unit	Requirement
1	M.F.R. (190°C, 5 kg load)	Gm/10 mins	To be submitted by Bidder's
2	Specified base density	Kg/mtr	
3	Material Grade		
4	Wall Thickness	Mm	
5	Pressure Rating		
6	Carbon Black	%	
7	Antioxidant	% by mass	
8	Overall Migration	Mg/dm ³	
9	Reversion	%	
10	Hydraulic Characteristics		
11	Continuous Temperature withstand capacity	°C	

B) FOR HDPE PIPE 125 MM DIA

Sl.No	Item Description	Unit	Requirement
1	M.F.R. (190°C, 5 kg load)	Gm/10 mins	To be submitted by Bidder's
2	Specified base density	Kg/mtr	
3	Material Grade		
4	Wall Thickness	Mm	
5	Pressure Rating		
6	Carbon Black	%	
7	Antioxidant	% by mass	
8	Overall Migration	Mg/dm3	
9	Reversion	%	
10	Hydraulic Characteristics		
11	Continuous Temperature withstand capacity	°C	

C) FOR HDPE PIPE 63 MM DIA

Sl.No	Item Description	Unit	Requirement
1	M.F.R. (190°C, 5 kg load)	Gm/10 mins	To be submitted by Bidder's
2	Specified base density	Kg/mtr	
3	Material Grade		
4	Wall Thickness	Mm	
5	Pressure Rating		
6	Carbon Black	%	
7	Antioxidant	% by mass	
8	Overall Migration	Mg/dm3	
9	Reversion	%	
10	Hydraulic Characteristics		
11	Continuous Temperature withstand capacity	°C	

D) FOR HDPE PIPE 200 MM DIA

Sl.No	Item Description	Unit	Requirement
1	M.F.R. (190°C, 5 kg load)	Gm/10 mins	To be submitted by Bidder's
2	Specified base density	Kg/mtr	
3	Material Grade		
4	Wall Thickness	Mm	
5	Pressure Rating		
6	Carbon Black	%	
7	Antioxidant	% by mass	
8	Overall Migration	Mg/dm3	
9	Reversion	%	
10	Hydraulic Characteristics		
11	Continuous Temperature withstand capacity	°C	

37.21.SCHEDULE OF DEVIATIONS

[TO BE ENCLOSED WITH TECHNICAL BID]

All deviations from this specification shall be set out by the Bidders, clause by Clause in this schedule. Unless specifically mentioned in this Schedule, the tender shall be deemed to confirm the purchaser's specifications

S.No	Clause No.	Details of deviation with justifications

We confirm that there are no deviations apart from those detailed above.

38.1. TECHNICAL SPECIFICATIONS FOR 11 KV RING MAIN UNITS (RMU) **With inbuilt FPI**

38.2. Scope:

This specification covers Design, Engineering, Manufacture, Assembly, testing, Inspection, packing of 11 kV motorized Ring Main Units with inbuilt FPI (Fully factory integrated & demonstrable at the time of inspection) with all accessories for trouble free and efficient performance and capability to connect/integrate the FRTU in future for enabling the SCADA functionality.

38.3. General

The RMU to be supplied against this specification are required for vital installations where continuity of service is very important. The design, materials and manufacture of the equipment shall, therefore, be of the highest order to ensure continuous and trouble-free service over the years.

The RMU offered shall be compact, maintenance free, easy to install reliable, safe and easy to operate and complete with all parts necessary for their effective and trouble-free operation. Such parts will be deemed to be within the scope of the supply irrespective of whether they are specifically indicated in the commercial order or not.

It is not the intent to specify herein complete details of design and construction. The offered equipment shall conform to the relevant standards and be of high quality, sturdy, robust and of good design and workmanship complete in all respects and capable to perform continuous and satisfactory operations in the actual service conditions at site and shall have sufficiently long life in service as per statutory requirements. In actual practice, notwithstanding any anomalies, discrepancies, omissions, incompleteness, etc. in these specifications, the design and construction all aspects, including materials and dimensions, will be subject to good engineering practice in conformity with the required quality of the product, and to such tolerances, allowances and requirements for clearances etc. as are necessary by virtue of various stipulations in that respect in the relevant Indian Standards, IEC standards, I.E. Rules, I.E. Act and other statutory provisions.

It shall also encompass all necessary project management, data engineering, acceptance testing, training, documentation, warranty services as efficiently as possible with minimum interruptions of power to Employer customers.

Tolerances on all the dimensions shall be in accordance with provisions made in the relevant Indian/IEC standards amended up-to date and in this specification. Otherwise the same will be governed by good engineering practice in conformity with required quality of the product.

38.4. Applicable Standards:

The RMUs shall be manufactured to the highest quality consistent with best practice and workmanship and in full accord with the Contractor's quality assurance plan. The RMUs and the work associated with their installation shall also conform to the Indian and equivalent international standards that are applicable.

The Bidder shall provide an English language copy of the applicable Indian and equivalent international standards met by the proposed RMU.

Rating, characteristics, tests and test procedures etc. for the RMU , protection Relays, monitoring and control devices and accessories including current transformer and voltage transformer shall comply with the provisions and requirements of the standards of the IEC and IS where specified. The latest revision or edition in effect at the time of bid invitation shall apply. The standards on which the present specification is based shall include the standards listed below, but not limited to the same and all the prevalent standards of IS/ IEC shall apply:

Standard	Description
IEC 60529	Classification of degrees of protection provided by enclosures of electrical equipment
IEC 60298	A.C metal-enclosed switchgear and control gear for rated voltages above 1 KV and upto and including 72 KV
IEC 1330	High voltage/Low voltage prefabricated substations
IEC 60694	Common specification for HV switchgear standards
IEC 60265	High-voltage switches Part 1:Switches for rated voltages above 1Kv and less than 52Kv
IEC 60801	Monitoring and Control
IEC 60185	Current Transformers
IEC 60186	Voltage Transformers
BS 159	Busbar
IEC 60137	Bushings
CP 1013 (British Code of Practice)	Earthing
IEC 60255	Specification for Static Protective Relays
BS 6231	Wires and wiring
IEC 61000	Electromagnetic compatibility
IEC 60129	Alternating current Disconnecter (isolators) and earthing switches
IEC 62271-200	Metal enclosed BS 5311 switchgear
IEC 62271-100	MV AC circuit breaker
IEC 60060-1/BS 923	High Voltage test technique
IEC 60034-1	Motors
IEC 60947-4-1	Control Gears
IEC 60623	Open Ni-Cd prismatic rechargeable cell
IEC 376	Filling of SF6 gas in RMU

38.5. Climatic Conditions:

SNo.	Location	Haryana
1	Maximum ambient air temperature	50 deg C
2	Minimum ambient air temperature	(-) 5 deg C
3	Average daily maximum ambient temperature	40 deg C
4	Max yearly weighted average ambient temperature	32 deg C
5	Isoceraunic level	45 days/year
6	Maximum altitude above sea level	1000 meters
7	Minimum relative humidity	26%
8	Max. relative humidity	100%
9	Average no of rainy days/ year	120
10	Basic wind Speed	47 m/s
11	Avg. Annual rainfall	900 mm
12	Pollution	Moderate
13	Maximum wind pressure	195 kg/m sq
14	Sesimic Zone	Zone-IV,III,II

38.6. General Technical Requirements

Sr No	Description	Requirement
1	Application	Three Phase-Three wire
2	Rated Voltage	12Kv
3	Service Voltage	11Kv
4	System Frequency	50 Hz
5	SF6 gas at a relative pressure	As per IEC 62271-200 & IEC 60694
6	Internal Arc test	ABFLR 20Ka FOR 1 Sec
7	Lightning Impulse withstand Voltage	75Kv Peak
8	Power Frequency withstand Voltage	28 Kv rms
9	Rated current of Circuit-breaker	630A
10	Rated Short time current withstand	20 KA for 3 sec
11	Rated Short circuit making current	50Ka
12	Number of operations at rated short circuit current on line switches, earthing switches and CB	5 close for line & earth switches and 25 nos for 11Kv vcb
13	Opening time of breaker (max.)	2.5 cycle
14	Closing time of breaker (max.)	3 cycle
15	Breaker Duty Cycle	0-3 min-CO-3min-CO
16.	Rated cable charging interrupting current of incomer – Load Break Switch	10 A
17.	Rated cable charging breaking current of breaker	25 A
18.	Insulating medium	SF6
19.	Interrupting medium	Vacuum
20.	Temperature Rise	Maximum permissible temperature rise as per table 3 of IEC 60694

38.7. General Construction

38.7.1. Configuration:

1 way extension type (one side) indoor/ outdoor application, 11 kV RMU consist of 1 no 630 A Load break switch along with one incoming and one outgoing cable provision.

2 Way extension type (one side) indoor/ outdoor application 11 kV RMU **shall** consist of 2 no's 11 kV 630 Amp motorized Isolators with earthing switches, suitable for 11 kV XLPE Aluminum conductor steel armoured cables of sizes 1 Run of 3CX400 mm², with provision of adding 1 no. 11 kV 630 Amp Local feeder/ Transformer control Vacuum Circuit Breaker **with** self powered O/C and E/F Numerical relays, plus 1 no. electronic Fault Passage Indicator per RMU and other communications capability for remote SCADA operation

3 Way Extension type (one side) Indoor/Outdoor application 11 kV RMU shall consist of 2 nos. 11 kV 630 Amp motorized Isolators with earthing switches connecting the RMU to incoming and outgoing main loop of 11 kV XLPE Aluminium conductor steel armoured cables, 1 no. 11 kV 630 Amp Local feeder/ Transformer control Vacuum Circuit Breaker with self powered O/C and E/F Numerical relays. There shall be provision for termination of 1 run of 11 kV XLPE cable of sizes upto 3CX400 mm² for the switches and VCBs. and other communications capability for remote SCADA operation shall also be provided.

3 Way Extension type (one side) Indoor/Outdoor application 11 kV RMU shall consist of 3 no. 11 kV 630 Amp Vacuum Circuit Breakers with self powered O/C and E/F Numerical relays out of which 2 nos VCBs for connecting the RMU to incoming and outgoing main loop of 11 kV XLPE Aluminium conductor steel armoured cables and 1 no. VCB for Local feeder/ Transformer control. There shall be provision for termination of 1 run of 11 kV XLPE cable of sizes upto 3CX400 mm² for the VCBs. 1

no. electronic Fault Passage Indicator per RMU and other communications capability for remote SCADA operation shall also be provided.

4 Way Extension type (one side) Indoor/Outdoor application 11 kV RMU shall consist of 2 no. 11 kV 630 Amp motorized Isolators with earthing switches connecting the RMU to incoming and outgoing main loop of 11 kV XLPE Aluminium conductor steel armoured cables, 2 no. 11 kV 630 Amp Local feeder/ Transformer control Vacuum Circuit Breaker with self powered O/C and E/F Numerical relays. There shall be provision for termination of 1 run of 11 kV XLPE cable of sizes upto 3CX400 mm² for the switches and VCBs. 1 no. electronic Fault Passage Indicator per RMU and other communications capability for remote SCADA operation shall also be provided.

5 Way Extension type (one side) Indoor/Outdoor application 11 kV RMU shall consist of 2 no. 11 kV 630 Amp motorized Isolators with earthing switches connecting the RMU to incoming and outgoing main loop of 11 kV XLPE Aluminium conductor steel armoured cables, 3 no. 11 kV 630 Amp Local feeder/ Transformer control Vacuum Circuit Breaker with self powered O/C and E/F Numerical relays. There shall be provision for termination of 1 run of 11 kV XLPE cable of sizes up to 3CX400 mm² for the switches and VCBs. 1 no. electronic Fault Passage Indicator per RMU and other communications capability for remote SCADA operation shall also be provided.

38.8. RMU Design Features:

The RMU are to be designed, manufactured and factory integrated without FRTUs and tested to be 'SCADA ready' and delivered at site. The SCADA ready RMU should be capable of being monitored and controlled by the SCADA by the communication system through optical fiber cable network. The manufacturer shall depute his representative for supervision of the installation, testing and commissioning of the RMU at site.

The RMU shall include potential free contacts so as to connect to SCADA via RTU/FRTU, so as to:

- (i) Monitor and control the open/closed status of the RMU circuit breakers and load break switches.
- (ii) Monitor the local/remote position of RMU manually-operated switches that can be used to enable and disable remote monitoring.
- (iii) Monitor the health of the power supply, which will include battery failure and low voltage indications.
- (iv) Monitor the open/closed status of RMU earthing switches.
- (v) Monitor the open/closed status of RMU enclosure doors in case of Hinge doors.
- (vi) Monitor for low SF₆ gas pressure indication.
- (vii) Monitor for circuit breaker relay operations.
- (viii) Monitor for indication of main-circuit fault detected by the RMU's FPI.
- (ix) Measurement of Data transfer from relay to the centralized SCADA system
- (x) All the Necessary interconnecting wires, cables, connectors, terminations and other wiring accessories such as terminal blocks required for interconnection between the RMU to connect to FRTU etc.
- (xi) The communication equipment.

38.9. Outdoor Enclosure features (for outdoor application only):

The RMUs shall be designed specifically for outdoor installation with ingress protection degree of IP54. They shall also be suitable for conditions in which they will be exposed to heavy industrial pollution, and high levels of airborne dust.

The outer enclosure shall be made of GI high tensile steel 2 mm thick with thick glands plates of 3 mm. The sheet steel and the fabricated parts shall be pretreated using 7 tank process and then coated by layer of zinc phosphate. A finish coat with high scratch resistance epoxy powder finish paint shall be applied over the primer. The coat thickness shall be minimum 100 micron +/- 25 micron.

The equipment in the proposed outdoor RMU shall be coated to meet these climatic conditions. In this respect, standards such as IEC 60870-2-2 covering equipment, systems, operating conditions, and environmental conditions shall apply along with IEC 60721, which covers the classification of such conditions. All live parts, high voltage components, excluding the HV cable termination of the switchgear shall be insulated/ protected in SF6 to provide complete proofing against dangers of flashover between phase and earth and between phases. In particular, the equipment shall be climate free in that no high voltage connection will be exposed to the environment.

The complete RMU unit shall be powder coating of RAL 7032 Grey to DIN Standard 43656.

38.10. Indoor enclosure features:

The tank shall be corrosion resistant stainless steel sheet of minimum 2 mm (as per relevant IS/ IEC) thickness with internal Arc Type tested and meet the 'sealed pressure system' criteria in accordance with the IEC 62271-200. This is a system for which no handling/ refilling of gas shall be required throughout the expected operating life, i.e. 30 years. Sealed pressure systems are completely assembled, filled and tested in the factory. The maximum leakage rate of SF6 gas shall be lower than 0.1% of the total initial mass of SF6 gas per annum. The filling pressure for the switchgear shall be just above the atmospheric pressure so as to reduce the tendency to leak. SF6 gas used for the filling of the RMU shall be in accordance with IEC376. It is preferable to fit an absorption material in the tank to absorb the moisture from the **SF6** gas and to regenerate the SF6 gas following arc interruption. There shall be no requirement to 'top up' the SF6 gas. The degree of protection for RMU tank, high voltage live parts, SF6 and VCB shall be IP 67. The Front cover mechanism and cable cover shall have IP2X degree of protection.

The RMU shall be suitable for mounting on plinth or housed in compact sub- station with provision for cabling through gland plate in the base and trench below. The RMU shall be designed so that the position of the different devices is visible to the operator on the front and operations are also visible. The RMU shall be identified by an appropriately sized label **which** clearly indicates the functional units and their electrical characteristics. The RMU shall be designed to be tamper proof so as to prevent access to all live parts during operation without the use of tools.

The RMU shall be completed with all connection and tinned copper or silver plated copper bus bar with continuous current carrying capacity of 630A as per relevant IEC/IS.. The bus bar shall be fully encapsulated by SF6 gas inside the steel tank. There shall be continuity between the metallic parts of the RMU and cables so that there is no electric field pattern in the surrounding air, thereby ensuring the safety of people. The earth bus bar shall be preferably enclosed in an enclosure to prevent theft/tampering.

All parts of main circuit to which access is required or provided shall be capable of being earthed prior to becoming accessible. This does not apply to removable parts which become accessible after being separated from the switchgear and control gear. The cables shall be earthed by an earth switch with short circuit making capacity in compliance with IEC 62271402. Circuit breaker shall not be closed in case Earth Switch is closed. The earth switch shall be fitted with its own operating mechanism and manual closing shall be driven by a fast-acting mechanism, independent of operator action.

Mechanical interlocking systems shall prevent access to the operating shaft to avoid all operator errors such as closing the earth switch when cable is charged

38.11. Interconnecting cables, wiring, connectors and terminal blocks:

The interconnecting wires, cables, connectors, terminations and other wiring accessories such as terminal blocks shall be in the scope of the manufacturer. Plug-type/screw type connectors shall be used for all interconnections. Suitable Disconnecter type terminal blocks shall be provided for CT circuits. In using a terminal block, no more than two cables or wires shall be connected to any of its individual terminals. Self-extinguishing fireproof vinyl marking strips shall be used to identify all external connection blocks. Marking tags shall be read horizontally. All terminals to which battery or other high voltages are connected shall be provided with fireproof covers. All individual status input, AC voltage input, and control output points shall be isolatable without the need to remove wiring by means of individual terminal blocks of the removable link type. In order to avoid open circuits on the secondary side of CTs, termination blocks with by-pass bridges shall be provided for all AC current inputs

Suitable fool-proof interlocks shall be provided to the earthing switches to prevent inadvertent or accidental closing when the circuit is live and the concerned Circuit Breaker/Isolator is in its "closed" position.

The unit shall be internal arc proof and tested and totally safe for human beings. The release of gas to be from the bottom of the unit, so that, even if the person is operating the unit, opening the cover, the release will be at the bottom. The release in no case should be from any side or top of the unit, as the same is unsafe for the operating personnel/pedestrian or general public. Bidder shall provide type test report to prove compliance to the 'Internal fault IAC- ABFLRas per IEC 62271-200. An anti-reflex mechanism on the operating lever shall prevent any attempts to reopen immediately after closing of the switch or earth switch. All manual operations shall be carried out on the front of the RMU.

38.12. Isolators:

The RMUs shall be equipped with 630Amp fault making/load breaking spring assisted ring switches, each with integral fault making/load breaking earth switches. The switch shall be naturally interlocked to prevent the main and earth switch being switched "ON" at the same time. The selection of the main and earth switch is made by a lever on the front which is allowed to move only if the main or earth switch is in „OFF" position. The Ring switches shall be capable for remote SCADA operation. The load break switch and earthing switch operating mechanism shall have mechanical endurance of at least 1000 operations.

Each INCOMING load break switch will have the following

1. Cable switch 12 kV, 630 A, 20 kA.
2. Mechanism for manual and motorised operation with integrated earthing switch
3. Cable bushing 630 A, standard C bushings.
4. Capacitive voltage indication fixed type - LED display.
5. Fault passage indicator with LED display and reset facility from remote having one contact for monitoring for each load break switch
6. Operation counters for each load break switch

7. ON, OFF, EARTH indication on the front mimic of the panel.
8. Cable box for termination of XLPE cable up to 3CX 400 sq. mm.
9. Cable entry bottom.
10. 2NO + 2 NC contacts for load break switch
11. 1NO+1NC contact for Earth switch
12. Local remote control switch for each load break switch
13. Set of 12 kV Right Angled Cable Boots.

RMU load break switch shall have following Digital inputs and Digital outputs

Digital Inputs

- (a) LBS Closed
- (b) LBS Open
- (c) Earth switch closed
- (d) Earth switch open

LBS local remote switch Status

Digital outputs

- (a) LBS Close
- (b) LBS open

FPI Digital Input

- (a) FPI operated

FPI Digital Output

FPI reset

The circuit breakers shall be maintenance free and the position of the power and earthing contacts shall be clearly visible on the front of the RMU through mimic. The position indicator shall provide positive contact indication in accordance with IS 9920. In addition, the manufacturer shall prove the reliability of indication in accordance with IS 9921.

The circuit breakers shall have 3 positions (or states): Open (disconnected), closed and earthed and shall be constructed in such a way that natural interlocks prevent all unauthorized operations. They shall be fully assembled, tested and inspected in the factory. Breaker operation counter should be provided. Breaker contact resistance should be ≤ 50 micro-ohms. An operating mechanism shall be used to manually close the circuit breaker and charge the mechanism in a single movement in manual mode or electrically motor operated. It shall be fitted with a local system for manual tripping by an integrated push button. There shall be no automatic re-closing. The circuit breaker shall be capable of closing fully and latching against the rated making current. Mechanical indication of the open, closed and earthed positions of the circuit breaker shall be provided.

The operating mechanism shall be 'SCADA ready' for remote operation.

The circuit breaker shall be associated with an integrated protection unit that will operate without any auxiliary power supply and shall include three toroid transformers incorporated in the transformer tee-off bushings, an electronic self-powered relay, a low energy release, and a "fast-on" test receptacle for protection testing (with or without CB tripping). The protection system shall ensure circuit breaker tripping as of a minimum operating current which is the rated current of the underground network to be protected. The CT settings shall be adjustable between 600 to 300/1Amp for feeder and 100-50/1A for distribution transformer, as per the requirement at site. Protection core CT complete details should be furnished (Burden, class, ALF).

There shall be provision for testing of cable without opening the front door by suitable arrangements. In case cables are to be tested with front door open, doors shall have interlocks such that doors can be opened only with earth switch in closed position & a cable test rod shall be provided which can be fixed on the terminations to facilitate testing.

Termination boots as approved by the Purchaser's should have proper opening to facilitate the testing. The opening shall be covered by means off removable protection cap.

In case of front door opened, it shall not be possible to operate the breaker. All panel covers shall be provided with anti-vandal screw bolts so that opening of panel covers is only possible with special tools, which shall be provided by the Bidder. This is required to prevent pilferage. The cable cover door shall be pad lockable and shall be Tamper and Arc proof. There shall be provision of hinged doors in the RMU. The circuit breaker and earth switch shall be lockable in the open or closed positions by 1 to 3 padlocks. Circuit Breaker shall have mechanical endurance of at least 2000 operations

Each OUTGOING Circuit Breaker will have the following

1. Circuit breaker 12 kV, 630 A
2. Mechanism for manual and motorised operation.
3. Self Powered protection relay providing over-current & earth fault protection.
4. Ring core current transformers for protection depending upon the transformer ratings 2.5 VA, 5P10 for protection
5. Operation counters
6. 4N0+4NC Auxiliary contacts for breaker
7. 2N0+2NC Auxiliary contact for Disconnecter
8. 1No+1NC contact for Earth switch
9. Local remote control switch for each breaker
10. Capacitive voltage indication fixed type
11. ON, OFF, TRIP indication on the front mimic of the panel.
12. Cable box for termination of XLPE cable up to 3CX400 sq. mm.
13. Emergency Trip Push Button.
14. Set of 12kV Cable boots.

RMU breaker shall have following Digital inputs and Digital outputs

Digital Inputs

- (a) CB Closed
- (b) CB Open
- (c) Earth switch closed
- (d) Earth switch open
- (e) Over current relay : operated
- (f) Earth fault relay : operated
- (g) CB local remote switch status

Digital outputs

- (a) CB Close
- (b) CB open

Protection relay

- (a) Communication on MODBUS thru RS232/485 port
- (b) SF 6 pressure low
- (c) Battery voltage low
- (d) AC & DC fail

Accessories:

1 operating handle

1 SF6 manometer with Auxiliary contact for monitoring status of GAS

21.13. Busbars

The three no. of continuous bus bars made up of tinned copper or silver plated copper of rating current 630 A shall be provided. The short time current withstand rating shall be 20 kA for 3 second.

21.14. Current Transformers and potential transformers

3 no. ring type, single core CTs shall be provided in each circuit breaker for protection purpose. The CTs shall conform to IS 2705. The design and construction shall be sufficiently robust to withstand thermal and dynamic stresses during short circuits. Secondary terminals of CTs shall be brought out suitably to a terminal block, which will be easily accessible for testing and terminal connections. The protection CTs shall be Epoxy resin cast with burden 5 VA for feeder and 2.5 VA for transformer and Accuracy class 5P10.

The RMU's other CTs / sensors, i.e., those used by Fault Passage Indicators (FPIs), shall be supplied by the FPI manufacturer. These CTs/sensors shall be an integral part of the FPI's design to ensure that they properly match the requirements of the FPI.

Appropriate capacity CTs and PTs shall be provided in the RMU for the metering purpose with the provision to provide the inputs to the FRTU for remote SCADA/ DMS/ OMS functionality. The meter shall not be in the scope of supplier but the provision and space for installation of the same in future shall be available in the separate enclosure for housing the Battery/ Charger etc.

21.15. Protection Relays

The RMU shall be equipped with self powered numerical relays with MODBUS/IEC -870-5-104/ IEC 61850 protocol as used to trip the RMU circuit breakers. The Circuit Breaker enclosures in the RMU shall be outfitted with a communicable-type numerical (feeder protection) relay, i.e., one for each circuit breaker. The protection relay's auxiliary contacts (minimum 2:DI&2:DO) shall be hardwired to the FRTU. The relay shall also interface with the FRTU via an RS 232/ RS 485 port in order to send, as a minimum, real-time phase current readings using the MODBUS protocol. For 11 kV Outgoing breakers Voltage &Energy readings will also be required using the MODBUS protocol from meter, if applicable.

The relay shall be provided with Phase protection of Definite time/ IDMT element for over current and earth fault with minimum PSM-0.05,Tsm-0.01 having standard characteristics of Standard Inverse, Very inverse, Extremely Inverse as per IEC 60255-3 standard. The Earth Fault Protection shall be provided of Definite time/ IDMT element having standard characteristics of Standard Inverse, Very inverse, Extremely Inverse as per IEC 60255-3 standard. The "Time Multiplier" with minimum set point of 0.05 TMS shall be available. The breaker shall have the provision of flag Relay for indication of Trip on Fault High set (DT) for over current and earth fault-min current setting-0.5 In, minimum Time Delay-20 millisecond. The relays shall be suitable numerical relay with necessary elements as per the Purchaser's approval.

On this basis, the relay as a minimum shall provide:

- (a) Phase Over Current Protection: (50/51)
- (b) Earth Fault Protection : (50N/51N)

Remote tripping and closing of RMU from the SCADA center shall be done through suitable tripping and closing Relay installed at Panel which will be interfaced with the tripping and closing coil of the RMU. A LED indicator shall be installed for signaling the occurrence of trip conditions.

Features and characteristics:

The numerical relay shall have the following minimal features and characteristics noting that variations may be acceptable as long as they provide similar or better functionality and/or flexibility:

- (a) It shall be housed in a flush mounting case and powered by the RMU power supply unit.
- (b) It shall have 3- phase over-current elements and One earth fault element.
- (c) IDMT trip current settings shall be 20-200% in steps of 1% for phase over-current and 10-80% in steps of 1% for earth fault.
- (d) Instantaneous trip current settings shall be 100-3000% in steps of 100% for phase over-current and 100- 1200% in steps of 100% for earth fault.
- (e) Selectable IDMT curves shall be provided to include, for example, Normal Inverse, Very Inverse, Extreme Inverse, Long Time Inverse, **and** Definite Time. Separate curve settings for phase over-current and earth fault shall be supported.
- f) For IDMT delay multiplication, the Time Multiplier Setting (TMS) shall be adjustable from 0.01 to 0.1 in 0.01 steps.
- g) The relay shall have local LED indications for Healthy, Trip, I>, I», IN>, and IN» conditions.

The relay shall also be provided with:

- (a) Alphanumeric Liquid Crystal Display (LCD)
- (b) Communications via a MODBUS/IEC — 104RS 232/RS485 port
- (c) Parameter change capability **that** is password protected

Capability to record up to 5 of the latest fault records duly time stamped and stored in non-volatile memory for subsequent reading via the above referenced RS485/RS 232 port

38.13. Bushings and cable terminations:

Each cable compartment shall, be provided, with three, bushings of adequate sizes to terminate the incoming and outgoing cables along with a terminal block (TB) located at convenient accessible location so as to wire all inputs & outputs (I/Os) up to the terminal block (TB). The bushings shall be conveniently located for proper bend so as to allow easy working and termination of cables. The cable termination shall be done with Heat shrinkable /Push ON termination method so that adequate clearances are maintained between phases & cable shall be held by HDPE (fire retardant) cleat. The clearance between phase to phase and phase to earth shall be as per IEC 61243 — 5 amended upto dates 1 run of 3CX400 Sq. mm shall be used for cable termination. All the cable secondary wiring should be routed through marshaling box separately for relay, CT etc. Bimetallic washer for tightening of cable to be provided.

38.14. Earthing:

The RMU outdoor metal clad, switchgear, Distribution Transformer, R.S. Joists, M.S Channels/M.S. angles etc., shall be equipped with an earth bus securely fixed along the base of the RMU. The earth bus bar shall be of GI strip (75sqmmX12) or copper strip(inside the RMU) having equivalent current rating and short circuit rating as per IEC/IS. Provision shall be made on end of RMU for connecting the earth bus to the earth grid by erecting suitable 2 earth pipes of 50mm dia. M.S. rod of 3 meter in Pits. Both the earth pipes are also to be connected in a grid formation. Necessary terminal clamps and connectors shall be included in the scope of supply.

38.15. Voltage indicator lamps and phase comparators.

Each function shall be equipped with a fixed type voltage indicator box on the front to indicate whether or not there is voltage in the cables. The capacitive dividers will supply low voltage power to the lamps. Three inlets can be used to check the synchronization of phases. These devices shall be in compliance with IEC 61958 standard.

38.16. Front cover

The front cover shall provide a clear mimic diagram that indicates the different functions. The position indicators shall give a true reflection of the position of the main contacts. They shall be clearly visible to the operator. The lever operating direction shall be clearly indicated in the mimic diagram. The bidder shall provide a marking plate showing RMU's main electrical characteristics.

38.16.1. Fault Passage Indicator

Fault Passage Indicators shall be installed on the Ring Main Unit. This shall facilitate quick detection of faulty cable. The FPI shall be in integral part of one isolator and shall be capable of displaying fault. The fault indication may be on the basis of monitoring fault current through the device. These devices shall be, electronic devices with their own energy source and connected to Single 3 phase Split Core

CTs (CBCT). These shall be provided with bright LED s / flag Indicators, which shall be clearly visible in the day time.

These shall have the following resetting facilities:

- (a) Manual reset
- (b) Resetting after a set time duration
- (c) Electrically reset from remote with at least 2-spare potential free contacts.
- (d) Resetting on restoration of LV

The unit shall have Short Circuit and Earth fault adjustable to different settings with separate Current transformer. They shall be fully field-programmable and shall have o/c setting 200-1000 A and E/F setting 10-150 A. To restrain operation of fault passage indicators due to inrush / switching current, settings of time delay of 1s-5s shall be available. It shall be possible to Test these indicators at site thru "Test" push button. The Fault Passage Indicators shall also be provided with a SCADA output contact. These shall confirm to the following standard:

IEC 60068-2-6, IEC 60068-2-9	Environmental testing- For Vibration, solar radiations
IEC 60950	Information Technology equipment- Safety
IEC 1000-2	Electromagnetic compatibility for low-frequency conducted disturbances and signaling in public low power supply
IEC 1000-4	EMC – Testing & Measurement
IEC 1000-6	EMC- Testing & Measurement

38.16.2. Motors

The RMU shall be fitted with spring charging motors rated for 24 V DC of high insulation class allowing the circuit breakers and load break switches to be operated without manual intervention. The max power rating shall be 240 W and max current drawn shall be 9 amp (+/-10%).

In addition to allowing circuit breaker tripping by the RMU's protection relays, the motorized operating mechanism shall be suitable for remote control by the SCADA.

The motors along with the supplied control card and push buttons shall allow Utility's personnel to electrically operate the circuit breakers and load break switches at site without any modification of the operating mechanism and without de-energizing the RMU.

38.16.3. Power supply, Battery and Charger

Each RMU shall be fitted with own power supply, including Auxiliary power transformer, batteries and battery charger, in a separate enclosure, suitable for operating the motors of the On-load Isolators and Circuit Breakers.. On this basis, the following operational specifications shall apply:

The Auxiliary power transformer shall be rated for 11000 V/230V, 1KVA, 50 Hz allowing for possible variation from 190 V to 300 V. The auxiliary power transformer's inputs shall be equipped with surge protection devices in accordance with IEC 62305.

The power supply unit shall conform to the following requirements:

- a. Input: 230 V AC nominal from the RMU's auxiliary power transformer allowing for possible variations from 190 to 300 V AC

- b. Output: Stable 24 V DC.
- c. Batteries: 24 V DC (2 Nos of 12 V DC each)
- d. The 24 V DC batteries shall have sufficient capacity to supply power to the following devices with a nominal backup of 12 hours:
- e. RMU's motors for a minimum of five (5) operations
- f. RMU's trip coils, close coils, FPI (in case required).

The batteries shall be of latest technology and shall have a minimum life of five (5) years at 25°C.

- a. The battery charger shall be fully temperature compensated.
- b. To prevent deep discharge of the batteries on loss of AC power source, the battery charger shall automatically disconnect all circuitry fed by the batteries following a user-adjustable time period or when the battery voltage falls below a preset value. If the battery voltage falls below the preset value, the time to fully recharge all batteries shall not exceed twenty-four (24) hours.
- c. An automatic battery checking device shall be provided to check the battery's health and initiate a battery-failed alarm signal in case battery deterioration is detected. Such detection may be based on comparing measurement values with set values (e.g., internal resistance, voltage, etc.).
- d. The battery charger shall be provided with an alarm displayed at the local control panel and remotely at the DAS to account for any of the following conditions:
 - (i) Low battery voltage
 - (ii) High battery voltage
 - (iii) Battery failed
 - (iv) Battery charger overvoltage

Grounded battery/battery-charger

In case the Auxiliary Power Transformer is not demanded in the NIT BOQ, then in that case provision of cable entry from the bottom with suitable cable rubber glands for the LT cable of size 3.5CX25 mm² for supplying the power to the battery charger and other equipment setc shall be provided.

38.17. Feeder Remote Terminal Unit (FRTU):- Deleted.

38.17.1. Paint

All paint shall be applied on clean dry surfaces under suitable atmospheric conditions by seven tank process and powder coating. The overall paint thickness shall not be less than 100 microns ±25 micron as standard. The paint shall not scale off or crinkle or be removed by abrasion during normal handling. The enclosure of the RMU shall be painted with shade Dark Gray i.e. RAL 7032. Sufficient quantity of touch-up paint shall be furnished for application at site.

38.17.2. Name Plate & Marking

All the components and operating devices of the RMU shall be provided with durable and legible nameplates containing all technical parameters. Name plates shall be suitably embossed with " PO no. with date", "PROPERTY OF DHBVN' & "CODE NUMBER" along with the following information. A Danger plate of appropriate size shall also be provided on the enclosure.

- a. Manufacturer's Name
- b. Month and year of supply

- c. PO Number
- d. Rated Voltage
- e. System Frequency
- f. Rated Short time withstand current for 3 sec
- g. Rated Impulse withstand Voltage
- h. Degree of Protection
- i. Type Designation or Serial no.
- j. Year of manufacture
- k. Applicable Rated values
- l. Mass of unit
- m. SF6 gas filling pressure

38.18. Testing

38.18.1. General:

The specified RMUs shall be subject to type tests, routine tests, and acceptance tests. Where applicable, these tests shall be carried out as per the standards stated in the specification. The type test produced by supplier shall be only from reputed NABL accredited testing laboratories such as CPRI from India and KEMA, Volta, KERI, CESI, ERDA etc from remaining part of the globe. Report from any other testing lab mentioned above shall not be accepted. In such a case manufacture has to perform the repeat type test for the RMU from these labs at his own cost. The type test report shall have been conducted during the period not exceeding five (5) years from the date of opening of the bid. In the event of any discrepancy in the test reports i.e. any test report not acceptable or any/ all type tests (including additional type tests, if any) not carried out, same shall be carried out without any cost implication to DHBVN.

Prior to acceptance testing, the supplier shall prepare and submit a detailed Manufacturing Quality Plan (MQP) and routine/ inspection test plan for review and approval by the Utility.

The manufacture may have in house testing lab for carrying out internal inspection and testing inside the factory witness by the utility. All the equipment used must be up to date and calibrated by reputed agency.

38.18.2. Type tests:

Following shall constitute the type tests:-

- (a) Lightning impulse test
- (b) Power Frequency Voltage Test
- (c) Temperature Rise Test
- (d) Measurement of Circuit Resistance
- (e) Rated Short Time and Peak Current Withstand test for main and earth circuit.
- (f) Breaking and Making Capacity Test for Breaker & Isolating Switches. Operational & Interlock Performance Test
- (g) Internal Arc Withstand Test.
- (h) Degree of Protection (IP Code verification tests)

- (i) Mechanical Endurance Tests for Isolator and Breaker.
- (j) Pressure withstand test & Leakage test on SF-6 Gas chamber
- (k) Dimensional and Visual Checks
- Im) Checking of partial discharge on complete unit.

The type test reports/ certificates of the above mentioned tests shall be supplied for approval before offering the material for inspection. The details of type test certificate according to the composition of the Switchboard shall also be submitted with the offer.

38.18.3. Routine tests:

The following routine tests shall be conducted by the manufacturer and the same shall be backed by the factory's quality control department test reports.

- a) Power Frequency Withstand Test.
- b) Dimensional & Visual Checks
- c) Operational & Interlock Tests of breaker & isolator switches
- d) Measurement of Circuit Resistance
- e) SF-6 chamber pressure withstands/leakage test.
- f) HV withstand test across isolator distance.
- g) HV withstand test of control and auxiliary circuits.
- h) Voltage Indication Tests.
- i) Breaker Contact Resistance Test
- j) Test to check the total time taken to clear the faults (relay pick up+ Trip coil pick up + breaker trip) for instantaneous & time delay modes under various settings of relay and trip coil thru primary current injection.
- k) IR Value.

Below routine test has to be provided on cable Boot for cable termination:

- a) Visual inspection of the final finished product.
- b) Intactness with Bushing.
- c) Insulation Test.
- d) AC HV test.

38.18.4. Acceptance tests:

All the tests specified under Routine Test Clause above shall be carried out as acceptance test on random samples as per sampling plan under IEC/IS for each lot.

Heat Run Test shall be carried out on one random sample/configuration/tender quantity as acceptance test.

In addition SCADA operation in RMU along with FRTU should be demonstrated during factory Inspection in manufacturer's own labs failing **which** the supplies shall not be accepted.

Note:Bidders should have all the requisite testing equipment's to carry out routine and acceptance test mentioned above including:

- a. Facility for primary current injection up to 1000amp.
- b. Facility to check total trip timing of breaker along with breaker main contacts through primary current injection.
- c. **Pre-commissioning test to be conducted on each RMU before installation and commissioning are as under-**
- d. IR value.
- e. HV test (AC).
- f. Primary injection with timer of breaker including relay and CT circuit.
- g. Contact resistance.

38.19. Pre-Dispatch Inspection:

Equipment shall be subject to inspection by a duly authorized representative of the DHBVN. Inspection may be made at any stage of manufacture at the option of the purchaser and the equipment if found unsatisfactory as to workmanship or material is liable to rejection. Supplier shall grant free access to the places of manufacture to DHBVN's representatives at all times when the work is in progress. Inspection by the DHBVN or its authorized representatives shall not relieve the supplier of his obligation of furnishing equipment in accordance with the specifications. Material shall be dispatched after specific MDCC (Material Dispatch Clearance Certificate) is issued by DHBVN. Following documents shall be sent along with material

- a. Test reports
- b. MDCC issued by DHBVN
- c. Invoice in duplicate
- d. Packing list
- e. Drawings & catalogue
- f. Guarantee / Warrantee card
- g. Delivery Challan
- h. Other Documents (as applicable)

38.19. Inspection after Receipt at Store

The material received at DHBVN Store will be inspected for acceptance and shall be liable for rejection if found different from the reports of the pre-dispatch inspection and one copy of the report shall be sent to DHBVN.

38.20. Packing

Bidder shall ensure that all equipment covered by this specification shall be prepared for rail/road transport (local equipment) and be packed in such a manner as to protect it from damage in transit.

38.21. Quality Control

The bidder shall submit with the offer, assurance plan indicating the various stages of inspection, the tests and checks which will be carried out on the material of construction, components during manufacture and after finishing, bought out items and fully assembled component and equipment including drives. As part of the plan, a schedule for stage and final inspection within the parameters of the delivery schedule shall be furnished. The Purchaser's or its nominated representative engineer shall have free access to the manufacturer/sub-supplier's works to carry out inspections.

38.22. Testing Facilities

Bidder shall have adequate in house testing facilities for carrying out all routine tests & acceptance tests as per relevant International / Indian standards.

38.23. Manufacturing Activities

The successful bidder will have to submit the bar chart for various manufacturing activities clearly elaborating each stage with quantity. This bar chart shall be in line with the Quality Assurance Plan submitted with the offer. This bar chart will have to be submitted within 15 days from the release of the order.

38.24. Spares, Accessories & Special Tools /Gauges

Bidder shall provide a list of recommended spares with quantity and unit prices for 5 years of operation after commissioning. The Purchaser may order all or any of the spare parts listed at the time of contract award and the spare parts so ordered shall be supplied as part of the definite works. The Purchaser may order additional spares at any time during the contract period at the rates stated in the Contract Document.

The bidder shall provide one no. SF6 gas leak indicator and one no. phase comparator/25 numbers of RMU. Bidder shall also provide 1 nos. FPI and VP1S per 10 nos. of RMU at no additional cost. A list of complete set of special tools and gauges required for erection & maintenance and installation procedure shall be submitted.

Bidder shall give an assurance that spare parts and consumable items will continue to be available through the life of the equipment which shall be 30 years minimum. However, the Purchaser shall give a minimum of 12 months notice in the event that the Bidder or any sub-vendor plans to discontinue manufacture of any component used in this equipment.

Any spare apparatus, parts or tools shall be subject to the same specification, tests and conditions as similar material supplied under the Contract. They shall be strictly interchangeable and suitable for use in place of the corresponding parts supplied with the plant and must be suitably marked and numbered for identification.

Bidder has to provide below spare with one lot of RMU

Sl.No	Name of Spare Parts	Required spares with above 100 No. of RMU	Required spares with above 30 No. upto 100 No of RMU	Required spares up to 30 No of RMU
1	Breaker Mechanism	4 No's	3 No's	2No's
2	Isolator Mechanism	4 No's	3 No's	2 No's
3	Trip Coil	5 No's	3 No's	2 No's

Sl.No	Name of Spare Parts	Required spares with above 100 No. of RMU	Required spares with above 30 No. upto 100 No of RMU	Required spares up to 30 No of RMU
4	Relay	5 No's	3 No's	2 No's
5	CT (all types)	3 Sets(1 Set = 3 Nos.)	2 Set	1 Set
6	Bolt (For Cable connection)	5 Sets (1 Set = 3 Nos.)	3 Set	2 Set
7	"L" Key (All size)	2 Sets	1 Set	1 Set
8	Operating Handle	1 No.	1 No.	1 No.
9	Cable Bushing (if replaceable; Like ABB)	15 (5 Set)	9 (3 Set)	NA
10	FPI	10 No's	5	NA
11	Push Button (ON & OFF Both)	10 (5 On & 5 Off)	6	NA
12	Manometer	5 No's	3	NA
13	Washer (S.S.)	20 No's	15	NA
14	Anti vandal Screw (all Size)	20 no's	15	NA
15	Cable Boot	5 Sets	3 Sets	NA

38.25. Drawings & Documents

Following drawings & documents shall be prepared based on DHBVN specifications and statutory requirements and shall be submitted with the bid:

- Completely filled in Technical Particulars
- General description of the equipment and all components including brochures.
- General arrangement for RMU
- Power flow diagram
- Foundation Plan
- Bill of material
- Experience List
- Type test certificates

Drawings/documents to be submitted after the award of the contract are as under :

Sl.No	Description	For Approval	For Review/Information	Final Submission
1	General Technical Particulars			V
2	General Arrangement drawings	V		V
3	Schematic Diagram	V		V
4	Bill of materials			V
5	Foundation Plan & loading details		V	V
6	Installation Instructions		V	V
7	Instruction for Use		V	V
8	Transport/Shipping dimension drawing		V	
9	QA & QC Plan	V	V	√
10	Test Certificates	V	V	

All the documents & drawings shall be in English language. After the receipt of the order, the successful bidder will be required to furnish five copies of all relevant drawings for DHBVN approval.

Instruction Manuals: Bidder shall furnish two soft copies (CD) and four hard copies of nicely bound manuals (in English language) covering erection and maintenance instructions and all relevant information and drawings pertaining to the main equipment as well as auxiliary devices.

38.26. Challenge Clause:-

The material offered/received after the inspection by the authorized inspecting officer may again be subjected to test for any parameter from any testing house/in-house technique of the Nigam & the results if found deviating/un-acceptable or not complying to Technical specification, the bidder shall arrange to supply the replacement within thirty (30) days of such detection at his cost including to & fro transportation. In addition, penalty @10% of cost of the inspected lot of material shall be imposed.

38.27. Warranty Period:-

The supplier shall be responsible to replace, free of cost, with no transportation or insurance cost to the purchaser, up to destination, the whole or any part to the material that in normal and proper use proved as defective in quality or workmanship, subject to the condition that the defect is noticed within 72 months from the date of commissioning. The consignee or any other officer of Nigam actually using the material will give prompt notice of each such defect to the supplier. The replacement shall be effected by the supplier within a reasonable time, but not, in any case, exceeding 45 days from the date of issue of notice in respect thereof, failing which, the purchaser reserve the right to dispose of defective material in any manner considered fit by him (purchaser), at the sole risk and cost of the supplier. Any sale proceeds of the defective material after meeting the expenses incurred on its custody, disposal handling etc., shall however be credited to the supplier's account and set off against any outstanding dues of the purchaser against the supplier. The warranty shall be for the entire duration of the warranty period.

38.28. Nigam's Quality Assurance Plan:

The Nigam's Quality assurance plan for the inspection of material at manufacturer's factory, post receipt inspection at Nigam's stores/turnkey contractor's site stores, dispatch of material, supply lots, counter checking etc is in force for the procurement and turnkey works which shall be applicable, as the case may be, alongwith upto date amendments, if any.

Guaranteed technical Particulars for RMU

S.No	Description	As specified by DHBVN	As furnished by Bidder
1.0	RMU Category	As per the Specifications	
2.0	RMU application	Out door	
3.0	Dielectric medium	SF6	
4.0	Interrupting medium	Vacuum	
5.0	System Frequency	50 Hz	
6.0	Rated Voltage	12 KV	
7.0	Service Voltage	11 KV	
8.0	Rated current- Line Switches	630 A	
9.0	Rated Current –CB	630 A for all type	
10.0	Rated Short time current withstand	20 KA for 3 sec	
11.0	Rated Short time Making capacity	50 KA	
13.0	Rated load interrupting line current	630 A	
14.0	Rated cable charging breaking current of breaker	25 A (minimum)	
15.0	No. of operations at rated short circuit current on line switches earthing switches and CB	5 Close for line and earth switch and 25 no for CB	
16.0	Opening time of breaker (max.)	2.5 cycle	
17.0	Closing time of breaker (max.)	3 cycle	
	Mechanical endurance for isolator and earth switch	Min 1000 operations	
	Mechanical endurance for Circuit Breaker	Min 2000 operations	
19.0	Electrical operations of E/Switch at rated current	To be provided by bidder	
20.0	Temp rise above ambient	50 Deg C	
21.0	Min Gas pressure	As per IEC 62271-200 & IEC 60694	
22.0	SF6 Gas pressure indicator with indicating bars/scale to measure the actual gas pressure (SCADA compatible)	To be provided by bidder	
23.0	SF6 Gas leakage detector	1 per 25 RMUs. Subject to minimum one number	
24.0	Guaranteed SF6 leakage detector	1 per 25 RMUS. Subject to minimum one number.	
25.0	Degree of protection	As per clause 6.2.1 & 6.2.2	
26.0	Internal arc test	ABFLR 20Ka for 1 SEC	
27.0	Lightning Impulse withstand Voltage	75 KVp	
28.0	Power Frequency withstand Voltage	28 KV rms	
29.0	SF6 Tank design	Hermetically/robotically sealed unpainted stainless steel enclosure with SF6 Gas. Sealed pressure system by Laser welding so that no refiling of gas is required for 30 years.	
30.0	Earth bus bars	In enclosure to prevent tampering	
31.0	Material & size	As per specification	
32.0	Earthing of Cables shall be earthed with earth switch with S/c making capacity as per IEC 129. Moving contacts of earthing switch shall be visible in closed position via transparent covers.	To be provided by bidder	
33.0	Incomer Load Break switch : Shall be SF6 type with least maintenance. Shall have at least 3 positions, Open, Close & earth with natural interlocks. Fitting of motor at site shall be possible & shall have mechanical interlock.	To be provided by bidder	

S.No	Description	As specified by DHBVN	As furnished by Bidder
34.0	Circuit Breakers:SF6 type with minimum maintenance and shall have atleast 3 positions i.e. Open, closed 7 earthed along with pre-fitted motors.	To be provided by bidder	
35.0	Protection Relay	Self-power numerical relay as per specifications	
36.0	Make of Relay	Suitable numerical relay with necessary elements or any other as per Purchaser's approval	
37.0	Flag indication on CB or LED indication on relay for Trip on fault	To be provided by bidder	
38.0	Testing of Cable- without opening the doors. If doors are opened then earth switch shall be in closed position and cable test rod shall be provided which can be fixed on terminations for testing purpose and it shall not be possible to operate, E/Switch or CB	To be confirmed. If separate test bushing are provided, it shall be covered with suitable antitheft covers with anti vandal screws.	
39.0	Protection against theft	Design of RMU shall be tamper & arc proof. Anti vandal screws shall be provided. Cable covers shall be pad lockable. All live parts/test bushings etc shall be covered with antitheft covers.	
40.0	Doors	Hinged doors shall be provided. The hinges for the doors need to be riveted and shall not have any access from outside. Bolted hinges shall not be acceptable.	
41.0	Voltage indicator box shall be fixed type-This device shall be in compliance with IEC 61958 standard	Capacitive dividers type which will supply low voltage to power the lamps and 3 inlets can be used to check phase sequence.	
42.0	Phase comparators	1 per RMU	
43.0	Cable clamps	HDPE (Fire Retardant)	
44.0	Cable termination	As given under	
45.0	Type	Heat/Cold shrinkable	
46.0	Size	Suitable for cable sizes upto 3Cx400	
47.0	Height	Shall be minimum 600 mm from the base plate	
48.0	Fault passage indicator (FPI)	One per RMU as a part of RMU	
49.0	Operating handle	To be provided by bidder as a part of RMU	
50.0	MIMIC Diagram on Front of Panel	To be provided by bidder	
51.0	Bus bar Material	Tinned Copper or Silver plated copper	
52.0	Cross Section	As specified by bidder	
53.0	Opening & Closing times (Max)	To be provided by bidder	
54.0	Current Transformer	Shall be epoxy resin and are mounted around the cable outside SF6 gas compartment. The CTs around the cables shall be supported on the sheet steel bracket base sized for CT's. Cts shall not be kept hanging or put on base frame directly.	

S.No	Description	As specified by DHBVN	As furnished by Bidder
55.0	Guarantee – From date of taking over by DHBVN	72 months from the date of commissioning	
56.0	Dimension (LXWXH) (mmxmmxmm)	To be provided by bidder	
57.0	Total weight	To be provided by bidder	
58.0	Paint	Dark Gray as per RAL 7032	
59.0	Type test of product	To be provided by bidder	
60.0	Availability of spares	Assurance by bidder for 30 years. List of spares as mentioned in specification to be provided alongwith RMU lot.	
61.0	Breaker operation counter	To be provided	
62.0	LBS & Earth Switch operation counter	To be provided	

39.1. TECHNICAL SPECIFICATIONS FOR OUTDOOR NON SEALED TYPE THREE PHASE 11 kV DISTRIBUTION TRANSFORMERS OF, 630 & 990kVACAPACITIES

TECHNICAL SPECIFICATIONS

FOR OUTDOOR NON SEALED TYPE THREE PHASE 11 kV DISTRIBUTION TRANSFORMERS OF, 400, 500, 630 & 1000kVACAPACITIES

TECHNICAL SPECIFICATION

FOR

Outdoor type Distribution Transformers of
11 kV/433-250V Class 400, 500, 630 & 1000 kVA

**Outdoor type Distribution Transformers of
11 kV/433-250V Class 630 & 990 kVA**

39.2 SCOPE:

This specification covers the design, engineering, manufacture, shop testing, supply & delivery of oil immersed, naturally cooled, three-phase, 50 Hz, double wound, outdoor type Distribution transformers of 400, 500, 630 & 1000 kVA capacity) Distribution Transformers for outdoor use along with metallic enclosure housing LV bushing with sealing facility.

It is not the intent to specify completely herein all the details of the design and construction of equipment. However the equipment shall conform in all respects to high standards of engineering, design and workmanship and shall be capable of performing in continuous commercial operation upto the Bidder's guarantee, in manner acceptable to the purchaser, who will interpret the meanings of drawings and specification and shall have the power to reject any work or material which, in his judgment is not in accordance therewith. The offered equipment shall be complete with all components necessary for their effective and trouble free operation. Such, components be deemed to be within the scope of Bidder's supply interceptive of whether those are specifically brought out in this specification and / or the commercial order or not.

Transformers will be plinth mounted and suitable for housing in compact substation.

39.3 STANDARDS:

Unless otherwise modified in this specification the transformer/materials shall conform in all respect to the relevant Indian/International Standard Specification, with latest amendments thereof some of them are listed below:

Title	India standard	International& Internationally recognized standard
Specification for Power Transformer	IS-2026:2011	IEC-60076
Specification for Distribution IS-1180:2014 IEC-60076 Transformer	IS-1180:2014	IEC-60076

Insulating Oil for transformer & IS-335/1983 BS-148 Switchgear	IS-335/1983	BS-148
Fittings & Accessories for Power IS-3639: 1968 ASTM D-1275 Transformer	IS-3639: 1968	ASTM D-1275
High Voltage Porcelain Bushings	IS-2099: 1986	IEC 296-1969
Low Voltage Porcelain Bushings	IS-7421-1988	
Dimensions for Outdoor Bushings	IS-3347	DIN 42531 to 33
Specification for Copper wire rods	IS-1244	ASTM B-49
Specification for colours for ready mixed paints	IS-5/1964	IEC-76
Guide for loading of oil immersed Transformers	IS-6600/1972	BS-148
Manual on Transformer	CBIP Publication No. 275	ASTM 0 -1275
Specification for Power Transformer	IS-2026:2011	IEC 296-1969
Insulating Oil for transformer & switchgear	IS-335/1983	
Specification of Insulating craft paper	IS:9335	
Specification for insulating press board	IS:1576	

The bidder shall use latest version of IS, however, wherever this standard is not available, corresponding IEC may be followed .

Material conforming to ISS or the internationally accepted standards, which ensure equal or higher quality than the standards mentioned above, would also be acceptable. In case the Bidders who wish to offer material conforming to the standards, salient points of difference between the standards adopted and the specific standards shall be clearly brought out in relevant schedule. Four copies of such standards with authentic English translations shall be furnished along with the other.

39.4 SERVICE CONDITIONS:-

The Distribution Transformers & other equipment material to be supplied against this specification shall be suitable for satisfactory operation under the following climatic Conditions as per IS-2026 (Part-I) latest revision.

SNo.	Location	Haryana
1	Maximum ambient air temperature	50 deg C
2	Minimum ambient air temperature	(-)5 deg C
3	Average daily maximum ambient temperature	40 deg C
4	Max yearly weighted average ambient temperature	32 deg C
5	Isoceraunic level	45 days/year
6	Maximum altitude above mean sea level	1000 meters
7	Minimum relative humidity	26%
8	Max. relative humidity	100%
9	Average no of rainy days/ year	120
10	Basic Wind Speed	47m/s
11	A vg. Annual rainfall	900mm
12	Pollution	Moderate
13	Maximum wind pressure	195 kg/ m sq
14	Sesimic Zone	Zone-IV ,III,II

The equipment shall be for safe operation in moderately hot and humid tropical climate, Conductive to rust and fungus growth.

39.5 PRINCIPAL PARAMETERS OF THE TRANSFORMER

The transformer shall be suitable for outdoor service as step down transformer. The electrical parameters of the transformer shall be as follows:

SNo.	Rated HV voltage	11 kV
1	Rated LV voltage	433 - 250 volts
2	Connection (HV)	Delta
3	Connection (LV)	Star
4	Vector Group	Dyn - 11
5	Material of winding	Electrolytic Copper, Double wound type
6	Type of cooling	ONAN
7	Max. Current density in HV & LV winding For copper wound TIF above 200 kVA	2.6.A/mm ²
8	Method of system earthing	Neutral Solidly earthed system

39.6 NO-LOAD VOLTAGE RATIO

The no-load voltage ratio shall be 11000/433 V for the relevant transformers.

39.7 TEMPERATURE RISE

The transformer shall be capable of operating continuously at its normal rating without exceeding the temperature rise limit. Temperature rise above ambient shall be as per IEC standard. For transformer windings, the temperature rise shall not exceed the limits measured by resistance method and in top oil, temperature rise shall not exceed the limit measured by thermometer when tested in accordance with IEC standard. The Transformer with higher temperature rise shall not be acceptable.

39.7.1 The limits of temperature rise mentioned above will have to be satisfied by the manufacturer by carrying the Heat run test at the lowest negative tap by feeding losses corresponding to the rated current of the tap.

39.8 LOSSES

39.8.1 The total losses at 50% & 100% loading for 11000/433 V DT shall not exceed the values given below:

kVA rating of T/F	Max., load losses at 50% load load at 75 C (watts)	Max., losses at 1'00% load at 75 C (watts)
400	1150	3330
500	1430	4100
630	1745	4850
1000	2620	7000

These losses are maximum allowable and there would not be any positive tolerance. However, the manufacturer can offer losses less than above.

39.9 The supplier shall quote No-Load loss in KW at the rated voltage and frequency.

The load loss in KW at rated voltage, frequency & output, for the temperature of 75 degree centigrade shall also be quoted. The supplier shall guarantee these loss figures.

39.10 IMPEDANCE:

The recommended percentage impedance at 75°C is 4.5% for rating of 630 kVA and below T/F and 5% for 1000 kVA T/F with a tolerance as per IS1180-2014

39.11 WINDING

39.11.1 The primary (HV) windings shall be connected in Delta and the secondary (LV) winding in Star (Vector system DYn11) so as to produce a positive displacement of 30 degree from the primary to secondary vectors of the same phase. The neutral of secondary windings shall be brought out to a separate insulated neutral terminal. The neutral is to be solidly earthed in a separate earth pit and the transformer body is to be connected to station grounding system.

HV windings shall consist of single coil design or cross over coil design. The copper wires for coil formation shall be of sufficient cross-sectional area to impart desired mechanical strength. All delta leads from HT coils as well as HT line leads should be taken out through DPC. The current density in these leads should not exceed 0.8A /sq.mm.

39.11.2. The winding shall be so designed as to produce minimum out of balance forces in the transformers. The current density for copper wound transformer shall be limited to 2.6 A I mm².

39.11.3. The winding design shall ensure that all the coil assemblies are of identical voltage ratio and shall be interchangeable and repairing of the winding could be made easily without special equipment.

39.11.4. The conductor used in the coil shall be best suitable to the equipment and all the permanent current carrying joints in the winding and leads shall be properly sleeved and crimped/brazed instead of jointing with solder or welding. All LV coil ends shall be provided with brazed/crimped lugs and HV coil ends by brazing/crimping.

39.11.5. Double paper covering shall be used for winding insulation both for HV & LV windings. Electrical grade epoxy coated insulated paper shall be used for inter-layer insulation of the HV& LV coils, corrugated cylinder made of pre-compressed board shall be provided between HV & LV winding. Angle shaped and rings made from pre-compressed board shall be used between end coil and the core.

OR

For 400/630/500/1000 kVA transformers HT winding shall have enamel conductor and L T winding shall have enamel copper insulation. Electrical Grade insulation Kraft paper in layers of total thickness not less than 4 MIL shall be used for interlayer insulation, DPC and Kraft paper used shall be of uniform density and free from any foreign particles and shall conform to IS: 698/56 and latest amendments thereof. The end turn of each layer shall be properly and fully covered to avoid interlayer flashover. Corrugated Cylinder made from pre compressed insulation board should preferably be used between LV and HV windings. The insulation of coils shall be vacuum impregnated in oil to develop full electrical strength in the

windings. All material used in the insulation and assembly of the winding shall be insoluble non catalytic and chemically inactive in the hot transformer oil and shall not soften or otherwise be adversely effected under operating conditions. The core and coil assembly shall be fully dried out in 'Air Drying oven' till the coils are shrunken to the designed level and are completely dried. Only then they will be impregnated in the transformer oil.

39.11.6. Minimum gap of 25 mm shall be maintained between the end coils and core.

39.11.7. The minimum insulation resistance values in Mega Ohms between winding and earth when the transformer is filled with oil should be:

Insulation resistance between winding and earth (Mega Ohm)					
	20°C	30°C	40°C	50°C	60°C
HV winding	800	400	200	100	50
LV winding	400	200	100	50	25

The insulation resistance values (HV windings) should be measured with a 2500 V Megger.

39.11.8. The overloading capacity transformer shall be as per IS-6600.

39.11.9. The value of unbalance current indicated by the ammeter shall not be more than 2% of the full load current.

39.12. CORE CONSTRUCTION

39.12.1 MATERIAL - CRGO METAL

The core shall be stack / wound type generally of high grade rolled grain annealed steel lamination having low loss and good grain properties, coated with hot oil proof insulation, bolted together and to the frames firmly to prevent vibration or noise. The complete design of core must ensure permanency of the core losses with continuous working of the transformers. The value of the maximum flux density allowed in the design and grade of lamination used be clearly stated in the offer. The bidder should offer the core for inspection and approval by the purchaser during manufacturing stage. Bidder's shall give notice for inspection with the following documents as applicable as a proof towards use of prime core material.

39.12.2. Invoice. of the supplier

39.12.3. Mills Test Certificate

39.12.4. Packing List

39.12.5. Bill of Loading

39.12.6. Bill of entry certificate to customs

39.12.7. Core clamping for CRGO Stacked core

39.12.8. MS channel shall be used on top and bottom

39.12.9. Core channel on LV side to be reinforced at equidistance, if holes/cutting is done for LT lead in order to avoid bending of channel

39.12.10. MS channel shall be painted with varnish or oil resistant paint

39.12.11. Clamping & Tie-rods shall be made of HT steel and shall be park arised .

39.13. Core clamping for CRGO wound core.

39.13.1. Core clamping shall be with top and bottom U-shaped core clamps made of sheet steel clamped HT steel tie rods for efficient clamping

39.13.2. MS core clamps shall be painted with varnish or oil -resistant paint.

39.13.3. MS rods shall be used as tie rods.

39.13.4. Suitable provision shall be made in the bottom core clamp/ bottom plate of the transformer to arrest movement or the active part.

39.13.5. The flux density in any part of the core and yoke at rated voltage & frequency shall be 1.69 Tesla. However, the maximum flux density in any part of the core and yoke with +12.5 percent combined voltage & frequency variation from rated voltage and frequency shall not exceed 1.9 Tesla. The transformers core shall be suitable for over fluxing (due to combined effect of voltage and frequency) upto 12.5% without injurious heating at full load conditions and shall not get saturated. The Bidder shall furnish necessary design data in support of this situation.

39.13.6. No load current shall not exceed 2% of full load current and will be measured by energizing the transformer at 433 volts, 50c/s on the Secondary, Increase of voltage of 433 volts by 12,5% shall not increase the no load current disproportionately high, Test for magnetic balance by connecting the LV phase by phase to rated phase voltage and measurement of an, bn, cn voltage will be carried out.

39.13.7. "The core material should be imported directly from the reputed manufacture, Core material shall be processed by slitting only, Core cutting/slitting be done in front of inspecting officers deputed by DHBVN", Details of the core shall be filled & supplied as per Annexure-E7 ,

39.13.8. Temperature rise

The temperature rise over ambient shall not exceed the limits described below:

- i) Top oil temperature rise measured by thermometer: 35 deg, C
- ii) Winding temperature rise measure by resistance: 40 deg, C

Bids not meeting the above limits of temperature rise will be treated as nonresponsive

39.14. TANK CONSTRUCTION

II ,I The tank shall be of robust construction in accordance with the best engineering practice, The main tank of the transformer shall be fabricated from tested quality of mild steel of adequate thickness i.e, minimum 4,00 mm, (for side walls) and 6,00 mm, (for top & bottom plates), The tank shall be valid (V shape welding fillet) inside of tank two outside welding of tank to bear more pressure to avoid bursting,

39.14.1. To provide rigidity and to meet the pressure inside the tank, due to short circuit current, the tank shall be suitably stiffened, The stiffeners wherever applicable are provided on all the four side walls of the tank, designed not to retain water.

39.14.2. The tank cover shall be slightly sloping towards HV bushing and shall provide facilities for draining of water.

39.14.3. The transformer tank shall be complete with all accessories, lifting lugs and shall be designed as to allow the complete transformer tank, filled with oil to be lifted by crane or other means without risk of any damage and transported by Rail/Road without straining any joint and without causing leakage of oil.

39.14.4. Bolted inspection covers shall be provided on top cover to inspect core, winding and have access to the bottom of bushing,

39.14.5. The tank shall be capable of withstanding the pressure of +/- 1 kg /cm² without deformation,

The transformer body should be welded from inside of the main tank body so that the joint is stronger due to V-shape welding fillet besides the outside welding be additional. The word DHBVNL shall be properly engraved on the top cover plate and side plate of tank body.

39.15. INSULATION MATERIAL:-

Material:-Electrical grade insulation Kraft papers and press Boards of standard should be used. For the use standard material the names of following firms have been approved.

Sr. No.	Name of insulating Material	Name of the firms
1	Press board	a. Senapathy whitely b. Raman Board
2	Craft paper	a. Ballarpur b. Padamjee c. Triveni d. Mis Sky touch Tapes Ltd ., Mumbai. e. Mis KLiM Enterprises, Mumbai. f. Mis Vijaya Mercantile Ltd. New Delhi. g. Mis Badri Enterprises, New Delhi.
3	Press panh paper	Senapathy whitely
4	Gaskets	a. New cork b. Talbros c. Mis Sky touch Tapes Ltd., Mumbai. d. Mis KLiM Enterprises, Mumbai. e. Mis Vijaya Mercantile Ltd. New Delhi. f. Mis Badri Enterprises, New Delhi.

39.15. 1. Spacers, axial wedges I runners used in windings shall be made of pre-compressed pressboard-solid, conforming to type B 3.1 of IEC 641-3-2. In case of cross-over coil winding of HV all spacers shall be properly sheared and dovetail punched to ensure proper locking. All axial wedgesl runners shall be properly milled to dovetail shape so that they pass through the designed spacers freely. Insulation shearing, cutting, milling and punching operations shall be carried out in such out in such a way, that there should not be any burr and dimensional variations

39.16. SURFACE PREPARATION AND PAINTING

39.16.1. The painting procedure shall be in line with the DHBVN requirement.

39.16.2. All paints shall be applied in accordance with the paint manufacturer's recommendations. Particular attention shall be paid to the following:

- a) Proper storage to avoid exposure as well as extremes of temperature and shelf life for storage
- b) Surface preparation prior to painting.
- c) Mixing and thinning
- d) Application of paints and the recommended limit on time intervals between coats.

39.16.3. All paints, when applied in normal full coat, shall be free from runs, sags, Wrinkles, patchiness or other defects.

39.16.4. All primers shall be well marked into the surface, particularly in areas where painting is evident, and the first priming coat shall be applied as soon as possible after cleaning. The paint shall be applied by

airless spray according to the manufacturer's recommendations. However, wherever airless. spray is not possible, conventional spray be used with prior approval of purchaser.

39.16.5. The supplier shall, prior to painting, protect nameplates, lettering gauges, sight glasses, light fittings and similar such items.

39.17. Cleaning and Surface Preparation:

39.17.1. All machining, forming, welding and other manufacturing activities shall be completed before surface preparation. All steel work surfaces shall be thoroughly cleaned of rust, scale, welding slag or spatter and other contamination by sand / shot blast cleaning or chemical cleaning by seven tank process including Phosphating to the appropriate quality in accordance with IS 6005.

39.17.2. The Pressure and Volume of the compressed air supply for the blast cleaning shall meet the work requirements and shall be sufficiently free from all water contamination.

39.17.3. All rough surfaces shall be filled with approved two pack filler and then rubbed down to a smooth finish

39.18. Protective Coating

As soon as all items have been cleaned and phosphated within four hours of the subsequent drying, they shall be given suitable anticorrosion protection of Zinc

39.19. Paint Material

Followings are the type of paints that may be suitably used for the transformer to be painted at shop and supply of matching paint to site:

i) Heat resistant paint (Hot oil proof) for inside surface.

ii) For external surfaces one coat of Thermo Setting Paint or 2 coats of Zinc chromate followed by 2 coats of polyurethane paint minimum dry film thickness 80 microns. chromate primer.

The color of the finishing coats shall be light admiral gray conforming to No. 697 of IS: 5:1961

The color of the finishing coats shall be light admiral gray conforming to No. 697 of IS: 5: 1961

39.20. Painting Procedure

39.20.1. All paints in anyone particular system, whether shop or site applied, shall originate from one paint manufacturer.

39.20.2. The paint shall only be applied in the manner detailed by the manufacturer e.g. conventional or airless spray and shall be applied under the manufacturer's recommended conditions.

39.20.3. Where the quality of film is impaired by excess film thickness (wrinkling, mud cracking or general softness) the supplier shall remove the unsatisfactory paint coatings and apply another. As a general rule, dry film thickness should not exceed the specified minimum dry film thickness by more than 25 %. In all instances, where two or more coats of the same paints are applied, such coatings should be of slightly contrasting colors.

39.20.4. Paint applied to items that are not being painted, shall be removed at supplier's expense, leaving the surface clean, un-stained and undamaged.

39.20.5. Damaged Paint Work

39.20.6. Any damage occurring to any part of the painting scheme shall be made good to the same standard of corrosion protection and appearance as that originally employed.

39.20.7. Any damaged paint work shall be made good as follows:

39.20.8. The damaged area, together with an area extending 25 mm around its boundary, shall be cleaned down to bare metal.

a) A priming coat shall immediately applied, followed by a full paint finish equal to that originally applied and extending 50 mm around the perimeter of the originally damaged.

b) The repainted surface shall present a smooth surface. This shall be obtained by carefully chamfering the paint edges before & after priming.

39.21. Dry Film Thickness

39.21.1. To the maximum extent practicable, the coats shall be applied as a continuous film of uniform thickness and free of pores. Over-spray, skips, runs, sags and drips should be avoided.

39.21.2. Each coat of paint shall be allowed to hardened before the next is applied as per manufacturer's recommendations.

39.21.3. Particular attention must be paid to full film thickness at edges.

39.21.4. The requirement for the dry film thickness (DFT) of paint and the material is to be used shall be as given below:-

Sr No	Paint Type	Area to be painted	No. of Coats	Total Dry Film thickness (Min)
1	Powder Paint a) Thermo setting powder	Inside Outside	01 01	20 Micron 60 Micron
2	Liquid paint a) Zinc Chromate (Primer) b) Polyurethane paint (Finish Coat) c) Hot Oil paint	Out side Out side inside	02 02	45 microns 80 micron 3.5 micron

39.22. CLEARANCES

The external electrical clearance between phase to phase and phase to earth shall be in accordance with Clause 7.1 of IS:2099 shall not be less than the values given below:-

Voltage Medium Clearance Phase to Clearance phase

Phase (mm) to Earth (mm)

11 kV Air 255 140

433V Air 75 40

The aforesaid clearances are minimum, and no negative tolerance on these clearances shall be allowed.

39.23. BUSHINGS

39.23.1. Terminal arrangement: The transformer shall be fitted with three high voltages and four low voltage outdoor types porcelain bushing of appropriate voltage and current rating and L T bushing shall be provided on the side of the tank. Each terminal including the neutral shall be distinctly marked and coloured for phase voltage on both HV and LV sides. The system of marking shall be in accordance with the latest amendment of relevant IS.

39.23.2. The electrical characteristics of high voltage bushing shall conform to late~ version of IS: 2099 and IS 3347. The low voltage bushing shall conform to latest version of IS: 7421. All porcelain bushing shall be homogeneous, free from flaws effecting its mechanical strength or dielectric quality. They should be well vitrified, uniformly glazed, tough and impervious to moisture. The creepage distance of all the bushing shall be 31 mm per kV of highest system voltage suitable for heavily polluted atmosphere and the protected creepage distance not less than 50% of total.

39.23.3. Bushing terminals: To avoid bimetallic action at the point of connection to The copper windings and to the external aluminium cables/conductors, both HV & LV bushing stem's shall be made of aluminium alloy I copper confirming to the requirement IS: 3347,

39.23.4. The terminal connectors shall receive XLPE cables or ACSR on HT side, The terminals shall be directly screwed on to the stem to secure effective sealing of the bushing, The transformers shall be provided with terminal lugs / thimbles of approximate size on bushings both on HV side LV side,

39.24. FITTINGS AND ACCESSORIES

The transformer shall be fitted with the following fittings & accessories

- (a) Two earthing terminals;
- (b) Oil level Indicator;
- (c) Lifting lugs and Platform lugs
- (d) Rating, diagram and terminal marking plate(s)
- (e) Silica gel breather of approved design containing min. 0.25kg dehydrated siliicagel.
- (f) Drain-cum-sampling valve (steel) welded to the tank.
- (g) Thermometer pocket with dial type thermometer on tank cover.
- (h) Air Release Plug.
- (i) Pressure relief device as standard fitment to operate at a pressure of 03 to 0.5 kg/cm².
- (j) Filling hole having P 1-1/4 thread (with cover) on the conservator.
- (k) Filter valve- 2 nos. on top and bottom ends of tank at opposite sides.
- (l) Conservator with filling hole and drain plug
- (m) Porcelain bushings with arcing horns and terminal connectors on HV side.
- (n) Porcelain bushing on LV side and HV side conforming to IS-3347, part-I and III of the latest version thereof with brass studs fitted with single gap arcing horns.
- (o) Bimetallic terminal connector for HV/LV Bushings connecting to XLPE cables/ACSR.
- (p) PSR Radiators duly tested for leakage and pressure.
- (q) Plain rollers (4 nos., bi directional) suitable for use on 1000 mm gauge track with clamping device or base mounting arrangement as required. For transformers up to 200 kVA the mounting arrangement shall be as per relevant IS

Note: (i) The fittings listed above are indicative and any other fittings which are generally required for satisfactory operation of the transformer are deemed to be included in the quoted price of the transformer

ii) Performance parameters of transformer should be as per DHBVN's approved technical specification.

Tap Changing Arrangement.

+5% to -10% in steps of 2.5% as per IS 1180 (part-I)

39.25. CONSERVATORS

39.25. 1. A Conservator shall be provided with each transformer.

The oil level gauge with low level alarm and the plain silica gel breathing device shall be fixed to the conservator which shall also be provided with a drain plug and a filling hole with a cover. In addition, the cover of the main tank shall be provided with an air release plug to enable trapped air to be released unless the conservator is so located as to eliminate the possibility of air being trapped in the main tank.

39.25. 2. The inside diameter of the pipe connecting the conservator to the main tank shall be within 25 to 50 mm and it should project into the conservator in such a way that its end is approximately 20 mm above the bottom of the conservator, so as to create a sump for collection of impurities. The minimum oil level (corresponding to -5°C) should be above the sump level. Breather pipe should be connected at top of the conservator tank with two bends at right angles.

39.26. SEALING GASKETS

All sealing washers and gaskets shall be made of 'oil and heat resistant Nitrile / Neoprene rubber/synthetic .rubber-bonded cork type RC-70C gaskets. The oil level in the transformer shall be made up to the required level while the transformer filled with oil is maintained at a temperature of 45°C . All steel screws, nuts and fasteners exposed to atmosphere shall be either galvanized or cadmium plated.

39.27. TRANSFORMER OIL

The transformer oil used shall comply with the requirements of the specification enclosed, in addition to the provision in the IS: 335-1993 (Latest). Oil sample will also be taken out from fresh stock of T/F oil to be tested as per latest IS: 335-1993. One sample of oil drawn from every lot of transformer offered for inspection may be tested at NABL accredited lab for tests.

39.28. BASE MOUNTING ARRANGEMENT

The under base of all transformers shall be provided with two 75x40x6mm. Channels with holes (at a centre to centre distance of 415mm) to make them suitable for mounting on plinth. Supporting design and drawing shall be submitted, in case any other arrangement is required for mounting, same shall be acceptable after approval of engineering in charge.

39.29. RATING AND TERMINAL MARKING PLATE(S)

Each transformer shall be provided with non-detachable rating diagram and terminal marking plate(s) of weather proof material, fitted in a visible position and showing the complete information as given under clause 170f IS: 1180-2014.

Further each transformer shall have inscription of Owner name- Purchase order and date.

39.30. TESTS:

39.30. 1. Routine Tests: All transformers shall be subjected to routine tests at the manufacturer's works in accordance with IS: 2026 and IS: 11802014

39.30. 2. Acceptance tests: The following tests acceptance tests are to be carried out in presence of purchaser's representative in accordance with procedure mentioned in the General specifications:

- (a) Measurement of winding resistance
- (b) Measurement of voltage ratio and check of voltage vector relationship
- (c) Measurement of impedance voltage/short circuit impedance and load-loss

(d) Measurement of no-load loss and current at full voltage.

(e) Measurement of insulation resistance

(f) Induced over-voltage withstand test

(g) Separate-source voltage withstand test

(h) Dielectric tests

(i) Oil sample test for BDV and moisture content

U) Visual examination & Measurement of Dimensions

(k) Pressure test

(l) Oil leakage test

39.31. Type Tests:

TYPE TESTS TO BE CONDUCTED ON ONE UNIT:

In addition to the Tests mentioned in para 21 following Tests shall be conducted.

39.32.1. Temperature rise test for determining the maximum temperature rise after continuous full load run. The ambient temperature and time of test should be stated in the test certificate.

39.32.2. Impulse voltage test: As per Clause No. 13 (With chopped wave) of IS - 2026 part III latest version.

39.32.3. Air Pressure Test: As per Cl. - 22.5 of IS- 1180-2014

39.32.4. Short Circuit withstand test: Thermal and dynamic ability.

39.32.5. Magnetic Balance Test.

39.32.6. The type test report(s) submitted by the bidder/ supplier from any NABL accredited laboratory shall be acceptable for participation of the bidder in the procurement/ empanelment process. In case NABL accredited laboratory happens to be that of manufacturer itself added precaution shall be taken to get type test and other tests witnessed in the laboratory by Nigam representative at the time of acceptance of material. Type test certificates for the tests carried out on prototype of same specifications shall be submitted along with the bid.

The purchaser may select the transformer for type tests randomly.

NOTE: Purchaser reserves the right to get all or any type/ special test carried out on One sample per 100 units or a part thereof. The test shall be conducted at manufacturer's works or any recognized laboratory or a Govt test house.

The supplier shall furnish calculations in accordance with IS: 2026 to demonstrate the thermal ability of the transformers to withstand short-circuit.

39.33. TEST VOLTAGES

Transformers shall be capable of withstanding the power frequency and impulse test voltage prescribed below:

Nominal system Highest voltage Impulse test Power frequency

Voltage voltage voltage

433 V (r ms) - - 3kV

11 kV (rms) 12 kV (rms) 95 kV (Peak) 28 kV (rms)

39.34. INSPECTION & TESTING

All tests and inspection shall be made at the place of manufacturer unless other wise especially agreed upon by the manufacturer and the purchaser. The manufacturer shall afford the inspector representing the purchaser all reasonable testing facilities, without charge to satisfy him that the material offered for inspection is in accordance with the requisite specifications.

The bidder shall give three weeks advance information to enable the purchaser to depute his representative for witnessing routine tests and acceptance thereof. The manufacturer shall provide all services to establish and maintain quality of workman ship at his works and that of his sub-contractors to ensure the mechanicalI electrical performance of components, compliance with drawings, identification and acceptability of all materials, parts and equipment as per latest quality standards of ISO 9001 :2000.

Nigam intends to purchase only High Quality material. For this purpose Stringent testing of the material shall be done as per procedure given below:-

1- On offer of inspection for distribution transformers by the firm ,a team of Nigam's officials may go to the Works site of the Manufacturer to pick up samples from offered lot and may send the same for testing as per GTP/Nigam's Technical Specifications at some Central Govt. Testing Lab. Or at Nigam's Transformer Workshop at Nigam's cost.

2- At the same time after receipt of offer for inspection, Inspection Agency will be deputed to inspect 1 00% of the offered lot.

3 The checking inspection reports received from both the agencies i.e. sample checking report from Central Govt. Testing Lab. and inspection report of inspecting agency will be scrutinized by Office of concerned Chief Engineer and, if both the reports are found O.K. the dispatch authorization will be issued to the firm.

4- After the receipt of material in the Stores, the tests for no load and full load losses shall be carried out on each TIF through post receipt inspection Committee constituted for the purpose.

(i) NO LOAD LOSSES AND FULL LOAD LOSSES ARE FIXED.

(ii) During post receipt inspection if the losses of any transformer are found more than the prescribed limit given in the technical specification, the transformer(s) shall be got replaced and in addition the penalty equivalent to the cost of the transformer supplied will be charged from the firm for supplying inferior quality material.

6- If during the post receipt inspection the failure rate of Transformer is more than 10% (Ten percent) of the lot supplied then the entire lot will be rejected and firm will not be entitle for any payment. The payment, if any, made will have to be 'refunded back within 10 days of giving such notice of failure to the supplier.

7- Inspection will be conducted every year, for the first 5 years on a 2% sample of the quantities supplied. Samples will be collected at random to establish that the guaranteed technical parameters are as per the submitted bid by the supplier. In the case of non-adherence, the purchaser may take suitable action on the supplier including cancellation of vendor registration and banning further dealings, depending on the gravity of the deviation. These random inspections may be entrusted to a third party.

8- If the distribution transformer rejection rate exceeds 5% of the total supply, the firm will be automatically blacklisted.

9- All such firm's who after giving inspection call do not put up materials to Inspecting Officer for inspection due to one or other reason, shall be required to remit RS.20,0001- as penalty for every such call made by the supplier.

39.35. STAGE INSPECTION

The purchaser's representative may carry out stage inspection of the transformers during manufacturing assembling stage. The purchaser shall have absolute right to reject the raw material/component/ sub assemblies or complete equipment not found to be conforming to the requirement of specification or being of poor quality workmanship. The stage inspection will particularly include following tests check besides the general Routine tests to be conducted during manufacturing stages as per manufacturer's standard practice.

a) Physical inspection/ checking of winding insulating material, core material for annealing and prime quality and other accessories !fitting of Transformer.

b) Measurement of Core area and flux density.

c) Verification of HV & L.V coils, conductor's size, 1.0., 0 .0., Axial length, Weight, Insulation coverng Etc

d) Measurement of thickness of tank plates (Top, bottom and sides) and to conduct air pressure & vacuum tests as specified in the specification, to ensure the adequate strength of the transformer tank body.

e) Sample testing of core material for checking specific loss and thickness of core plates.

f) Visual and dimensional check during assembly stage of core.

g) Check for proper provisions of spacers and bracing outline drawing, provision for all fittings, finishing etc. The purchaser at his option may collect the sample of the following raw material! component for independent testing:

a) ERGO Lamination - One specimen sheet of 300- 500 mm length and 50-75 mmwidth (for each lot)

b) HV Winding wire- 1250 mm length specimen for each type

c) LV Winding wire- 1250 mm length specimen for each type

d) Transformer oil - 2 samples of 5 Liters each

To facilitate stage inspection, the supplier should intimate complete schedule of manufacturing programme of the transformers at least 15 days in advance to the concerned purchasing authority. At least 25% of the transformers shall be offered in the shape of finished core - coil assembly. The inspecting officers during the course of stage inspection may seal these core-coil assemblies.

a) The manufacturing program shall not be interrupted in case purchaser's representative does not reach within seven days of the date of intimation.

39.36. WARRANTY PERIOD

The supplier shall be responsible to replace, free of cost, with no transportation or insurance cost to the Purchaser, up to destination, the whole or any part of the material which in normal and proper use proves the defective in quality or workmanship, subject to the condition that the defect is noticed within 72 months from the date of commissioning and shall be for entire duration of the warranty period. The consignee or any other officer of Nigam actually using the material will give prompt notice of each such defect to the supplier. The replacement shall be effected by the supplier within a reasonable time, but not, in any case, exceeding 45 days. The supplier shall, also, arrange to remove the defective within a reasonable period, but not exceeding 45 days from the date of issue of notice in

respect thereof, failing which, the purchaser reserve the right to dispose of defective material in any manner considered fit by him (Purchaser), at the sole risk and cost of the supplier. Any sale proceeds of the defective material after meeting the expenses incurred on its custody, disposal handling etc., shall however be credited to the supplier's account and set off against any outstanding dues of the purchaser against the supplier. The warranty for 72 months shall be for entire duration of warranty period.

39.37. DOCUMENTATION:

All drawings shall conform to International Standards Organization (ISO) 'A' series of drawings sheet/Indian Standards Specification IS-656. All drawings shall be in ink and suitable for microfilming. All dimensions and data shall be in SI Units

39.38. LIST OF DRAWINGS AND DOCUMENTS:

The tenderer shall furnish four sets of following drawings along with his offer: -

- a) General outline and assembly drawings of the equipment.
- b) Graphs showing the performance of equipment in regard to magnetization characteristics.
- c) Sectional views showing:
 - a. General constructional features.
 - i) The materials / gaskets/ sealing used.
 - ii) The Insulation, the winding arrangements, method of connection of the primary / secondary winding to the primary / secondary terminals etc.
 - iii) Porcelain used and its dimensions along with the mechanical and electrical characteristics.
- d) Arrangement of terminals and details of connection studs provided.
- e) Name Plate.
- f) Schematic drawing.
- g) Type test reports in case the equipment has already been type tested.
- h) Test reports, literature, pamphlets of the bought out items and raw material.

39.38.1. The successful tenderer's shall within 15 days of placement of order, submit three sets of final versions of all the above said drawings for purchaser's approval. The purchaser shall communicate his comments / approval on the drawings to the supplier within 30 days. The supplier shall, if necessary, modify the drawings and submit three copies of the modified drawings for purchaser's comments. After receipt of purchaser's approval, the suppliers shall within 15 days, submit 12 prints and two good qualities reproducible of the approved drawings for purchaser's use.

39.38.2. Six sets of the type test reports, duly approved by the purchaser, shall be submitted by the supplier for distribution before commencement of supply. Adequate copies acceptance and routine test certificates, duly approved by the purchaser, shall accompany the dispatched consignment.

39.38.3. The manufacturing of the equipment shall be strictly in accordance with the approved drawings and no deviation shall be permitted without the written approval of the purchaser. All manufacturing and fabrication work in connection with the equipment prior to the approval of the drawing shall be at the supplier's risk.

39.38.4. 16 sets of nicely printed and bound volumes of operation, maintenance and erection manuals in English Language, for each type and rating of equipment supplied shall be submitted by the supplier for distribution, prior to the dispatch of the equipment. The manual shall contain all the drawings and information required for erection, operation and maintenance of the distribution transformer. The manual shall also contain a set of all the approved drawings, type test reports etc.

39.38.5. Approval of drawings / work by purchaser shall not relieve the supplier of his responsibility and liability for ensuring correctness and correct interpretation of the drawings for meeting the requirement of the latest version of applicable standards, rules and codes of practices. The equipment shall conform in all respects to high standards engineering, design workmanship and latest revisions of relevant standards at the time to ordering and purchaser shall have the power to reject any work or materials which, in his judgement is not in full accordance therewith.

39.39. PACKING

Transformer shall be suitably packed as per the standard practice while dispatching from the works. Although the method of packing is left to the discretion of the manufacturer it should be robust enough for handling normally encountered during transportation by road/rail. All accessories shall be dispatched in suitable boxes or crates. They shall be securely bound with wire and shall have all descriptive marking stamped thereon.

39.40. INSTRUCTIONS MANUAL

Eight sets of the instruction manuals shall be supplied at least four (4) weeks before the actual dispatch of equipment. The manuals shall be in bound volumes and shall contain all the drawings and information required for erection, operation and maintenance of the transformer. The manuals include amongst others, the following particulars:

- a) Marked erection prints identifying the components, parts of the transformer as dispatched with assembly drawings.
- b) Salient technical particulars of the transformer
- c) Copies of all final approved drawings.
- d) Detailed O&M instructions with periodical check lists and Performance etc.

39.41. COMPLETENESS OF EQUIPMENT

i) All fittings and accessories, which may not be specifically mentioned in the specification but which are necessary for the satisfactory operation of the plant, shall be deemed to be included in the specification and shall be furnished by the contractor without extra charges. The equipment shall be complete in all details, whether such details are mentioned in the specification or not, without any financial liability to the Purchaser under any circumstances.

ii) All deviations from this specification shall be separately listed under the requisite schedules, in the absence of which it will be presumed that all the provisions of the specification are complied with by the bidder.

39.42. INSPECTION:

All tests and inspection shall be made at the place of manufacturer and unless otherwise especially agreed upon the manufacturer and the purchaser at the time of purchase. The manufacturer shall afford the inspector representing the purchaser all reasonable facilities, without charge to satisfy him that the material is being furnished in accordance with specification.

The bidder shall give 15 days (for local supplies) and 30 days (in case of foreign bidders) advance information to enable the purchaser to depute his representative for witnessing acceptance routine tests.

The manufacturer shall provide all services to establish and maintain quality of workman ship in his works and that of his sub-contractors to ensure the mechanical/electrical performance of components, compliance with drawings, identification and accept ability of all materials, parts and equipment as per Nigam intends to purchase only High Quality material. For this purpose stringent testing of the material can be done. Inspection can be got done from third party Inspection agency or from Nigam's own officers. Nigam reserves the right of 100% testing of the transformers. The details of source of material shall be supplied duly filled as per Annexure-E8.

39.43. QUALITY ASSURANCE PLAN:

39.43.1. The Bidder shall furnish following information along with his bid. Information shall be separately given for individual type of material offered.

39.43.2. Statement giving list of important raw materials, names of sub-supplies for the raw materials, list of standards according to which the raw materials are tested. List of tests normally carried out on raw materials in the presence of Bidder's representative, copies of test certificates.

39.43.3. Information and copies of test certificates as in (1) above in respect of bought out accessories.

39.44. List of manufacturing facilities available.

39.44.1. Level of automation achieved and list of areas where manual processing exists.

39.44.2. List of areas in manufacturing process, where stage inspections are normally carried out for quality control and details of such test and inspection.

39.44.3. List of testing equipment available with the bidder for final testing of equipment along with valid calibration reports shall be furnished with the bid. Manufacturer shall possess 0.1 class instruments for measurement of losses

39.44.4. The successful Bidder shall within 30 days of placement of order submit following information regarding list of new materials as well as bought out accessories and the names of sub-suppliers selected from those furnished along with offer.

39.45. DOCUMENTATION:

The Bidder shall furnish along with the bid the dimensional drawings of the stems offered indicating all the fittings.

39.45.1. Dimension's tolerances

39.45.2. Weight of individual components and total weight.

39.46. PACKING & FORWARDING:

39.46. 1. The packing shall be done as per the manufacturer's standard practice. However, it should be ensured that the packing is such that, the material would not get damaged during by Rail/ Road/ Sea.

39.46. 2. The marking on each package shall be as per the relevant IS.

39.47. MANDATORY SPARES:

Mandatory spares shall be supplied as per the purchaser's requirement.

39.48. Transformer & Metallic box Sealing facility

The transformer should have facility to seal the transformers Top Plate & its body and also the Metal box, housing the other equipment(s) The metal box shall have pad-lock arrangement & complete protection from dirt, rain-water & other pollutants & shall comply to IP:53 protection or better.

39.49. RATING AND TERMINAL MARKING PLATES:

There shall be rating plates on the transformer containing the information specified in clause 15.2 of IS: 2026-1977 (part-i). No load & full load losses of the transformer should also be mentioned on the rating plate. The following additional information must also be punched on the plate and imposed two opposite sides of the body of T/F.

- i) Purchase Order No & Date.
 - ii) Date of inspection.
 - iii) Property of DHBVN
 - iv) Make
 - v) Guarantee period
 - vi) 5-Star rating label in accordance with colour design, logo
- etc., shall be provided on the transformer as per the design recommendations of Bureau of Efficiency (BEE)

39.50. PENALTY FOR NON PERFORMANCE:

39.50.1. Purchaser reserves the right to reject any transformer during the test at supplier's works, if it is found that actual measured losses are more than the values quoted by the bidder

39.50.2. Transformer with temperature rise and impedance beyond the Guaranteed values.

39.50.3. Purchaser reserves the right to reject any transformer during the test at supplier's works, if the temperature rise exceeds the guaranteed values.

39.50.4. Purchaser reserves the right to reject any transformer during the test at supplier's works, if the impedance values differ from the guaranteed values including tolerance.

39.50.5. Purchaser also reserves the right to retain the rejected transformer and take it into service until the Bidder replaces it with a new transformer at no extra cost. The delivery as per contract will be counted when the new transformer as per specification is provided by the manufacture.

39.50.6. During post inspection if the losses of any DT are found more than the prescribed limit the DT shall be got replaced and in addition the penalty equivalent to cost of DT will be charged from the supplier. If the DT rejection rate exceeds 5% of the total supply the firm will be blacklisted

39.51. PROTOTYPE TRANSFORMER

The prototype transformer on which type test got conducted shall be supplied to DHBVN duly sealed after completion of type testing in the beginning itself before commencement of supply. The bidder shall furnish an affidavit that all his balance transformers shall meet with prototype in all respects (internal & external). The nigam can randomly select any transformer and verify the internal/external details with the prototype sample at any time during warranty period. Type test certificates for the tests carried out on protocol of same specifications shall be submitted along with the bid. The purchase may select any transformer from the offered lot for inspection during subsequent lots for carrying out temperature rise test from any Govt approved lab.

39.52. CHALLENGE CLAUSE

The material offered/received after the inspection by the authorized inspecting officer may again be subjected to the test for losses or any other parameters from any testing house/in house technique of the Nigam having requisite capabilities and facilities. The results if found deviating/unacceptable or in non compliance with the approved GTP's, the lot shall be rejected and bidder shall arrange to supply the within thirty (30) days of such detection at his cost including to' & fro transportation. In addition to this penalty @ 10% of cost of the rejected lot of material shall be imposed.

39.53. Nigam's Quality Assurance Plan:-

The Nigam's Quality assurance plan for the inspection of material at manufacturer's factory, post receipt inspection at Nigam's stores/ turnkey contractor's site stores ,dispatch of material, supply lots, counter checking etc is in force for the procurement and turnkey works which shall be applicable, as the case may be, alongwith up-to-date amendments, if any.

39.54. GUARANTEED TECHNICAL PARTICULARS

The guaranteed technical particulars of the transformer shall be given by the tenderer (Annexure-E6) along with the tender. Tenders without GTP'S shall be out rightly rejected.

ANNEXTURE E6

GUARANTEED & OTHER PARTICULARS FOR DISTRIBUTION TRANSFORMERS -

400,500,630 &1000,11/0.433 kV DTs

(To be furnished by the Manufacturer)

SI.N Description

1. Make & Manufacturer
2. Place of Manufacture
3. Voltage in kV
4. Rating in kVA
5. Core Material used and Grade
 - a) Flux density
 - b) Over fluxing without saturation (Curve to be furnished by the Manufacturer in support of his claim)
6. Maximum temperature rise of
 - a) Windings by resistance method
 - b) Oil by Thermometer
7. Magnetizing (No load) Current at
 - a) Normal Voltage
 - b) Maximum Voltage
8. Core loss in watts
 - a) Normal Voltage
 - b) Maximum Voltage
9. Resistance of Windings at 20 deg. C
(with 5% tolerance)
 - a) HV Winding (ohms) b)
LV Winding (ohms)
10. 50% load losses (watts) at 75 deg. c
- 11 .100% Load Losse's at 75 deg. C (watts)
12. Current density used for

a) HV Winding

b) LV Winding

13. Clearances

a) Core & LV

b) LV & HV

c) HV Phase to Phase

d) End insulation clearance to Earth

e) Any point of winding to tank

14. Efficiency at 75 deg. C.

a) Unity P.F. &

b) 0.8 P.F

1) 125 % load

2) 100 % load

3) 75 % load

4) 50 % load

5) 25 % load

15. Regulation at

a) Unity P.F.

b) 0.8 P.F. at 75 deg. C

16. % Impedance at 75 deg. C

17. Flash Test

HV 28 kV/ 50 HZ for 1 minute

LV 3 kV/ 50 HZ for 1 minute

18. Over potential Test Double Voltage &

19. Double frequency for 1 minute

20. Impulse test

21. Weight content of

a) Core Lamination (min.)

b) Windings (min.)

c) Tank & Fittings

(Thickness of side walls & thickness of top/bottom plate of DT)

d) Oil

e) Oil qty (min.)

f) Total Weight

22, Oil Data

1, Qty for first filling (mm)

2. Grade of oil used

3. Maker's name

4. BDV at the time of filling

23, Transformer:

1) Overall length x breadth x height

2) Tank length x breadth x height

3) Thickness of plates for

a) Side plate (min .)

b) Top & Bottom plate (min.)

24. Radiation:

1) Heat dissipation by tank walls exclusive & bottom

2) Heat dissipation by. cooling tube

3) Dia. & thickness of cooling tube

4) Whether calculation sheet for selecting cooling area to ensure that the transformer is capable of giving continuous rated output without exceeding temperature rise is enclosed.

25. Inter layer insulation provided in design for

1) Top & bottom layer

2) In between all layer

3) Details of end insulation

4) Whether wedges are provide at 50 % turns of the HV coil

26. Insulation materials provided

a) For Conductors (1) HV (2) LV

b) For Core

27. Material and Size 'of the wire used

1) HV

a) SWG/mm

b) Dia 2)

LV

a) Strip size.

b) No. of Conductors in parallel.

c) Total area of cross section (sq. mm.)

28. Is the name plate gives all particulars as required in Tender

29. MCCB (if provided) as per Nigam latest technical specification.

30. Particulars of Bushings HVI LV ·

1) Maker's name

2) Type IS-3347/IS- 1180

3) Rating as per LS.

4) Dry power frequency voltage withstand test

5) Wet power frequency voltage withstand test Note:

The following shall be specifically confirmed

1. Whether the offer conforms to the limits of impedance mentioned in the Specification

2. Whether the offer conforms to the limits of temperature rise mentioned in the specification.

3. Whether the losses of the transformers offered are within the limits specified

4. Whether the transformers offered is already type for the design and test reports enclosed.

ANNEXTURE E7

ADDITIONAL DETAILS

SI. No. Description

1. Core Grade
2. Core diameter (mm)
3. Gross Core area (cm)
4. Net Core area (cm)
5. Flux density (Tesla)
6. wt. of Core (kg)
7. Loss per kg. of Core at the
Specified Flux density (Watts)
8. Core window height
9. Center to center distance of the core (mm)
10. No. of LV. Turns
11. No. of HV turns
12. Size of LV Conductor bare/ covered (mm)
13. Size of HV conductor bare/ covered (mm)
14. No. of parallels
15. Current density of LV winding amps/sq.mm.
16. Current density of HV winding amps/ sq.mm
17. Wt. of the LV winding for Transformer kg.
18. Wt. of the HV winding for Transformer kg.
19. No. of LV Coils/phase
20. No. of HV coils/phase
21. Height of LV Windings mm
22. Height of HV Windings mm
23. 10/00 of LV Winding mm
24. 10/00 of HV winding mm

25. Size of the duct in LV winding mm
26. Size of the duct in HV winding mm
27. Size of the duct between HV & LV mm
28. HV winding to LV winding clearance mm
29. HV winding to tank clearance mm
30. Calculated impedance %
- 31 HV to earth creepage distance mm
- 32 LV to earth creepage distance mm

Annexure E8:

SOURCE OF MATERIALS/PLACES OF MANUFACTURE TESTING AND INSPECTION

Sl. No. Item Source of Material Place of Place of testing and Manufacture inspection

1. Laminations
2. Aluminium Conductor
3. Insulated winding wires
4. Oil
5. Press Boards
6. Kraft Paper
7. MS Plated / Angles/ Channels
8. Gaskets
9. Bushing HV/ LV
10. Paints

Reference Abbreviations Name and Asset

ACRONYMS

Reference Abbreviations Name and Asset	
IEC	International Electro Technical Commission Bureau Central de la Commission Electro Technique International, Rue de verembe Geneva, Switzerland
ISO	International Organization for Standardization. Danish Board of Standardization Aurchoegyej-12, DK-2900, Heerpup, DENMARK
ISS	Indian Standard Bureau of Indian Standards Nanak Bhawan 9, Bahadur Shah Zafar Marg, NEW DELHI-110002, INDIA

GUARANTEED CHARACTERISTICS OF NEW TRANSFORMER OIL IN DRUMS/TANKERS AND IN TRANSFORMERS

A. OIL IN DRUMS/TANKERS

S.No.	Characteristics	Requirement
1	Appearance	Oil shall be clear & transparent & free from suspended matter or sediments.
2	Density at 29.50C (Max.)	0.89 g/cm ²
3	Kinematics viscosity at 27°C (Min .)	27CST
4	Interfacial tension at 27°C (min .)	0.04 N/M
5	Flash point (Min.)	140°C
6	Pour point (Max.)	_DC
7	Neutralization value a) Total acidity (Max.) b) In organic acidity	0.03 mg KOH/gm NIL
8	Corrosive sulphur	Non-corrosive
9	Electric strength (Break down voltage) Min. a) New untreated oil: If the above value is not obtained the oil shall be treated . b) 60 kV (rms) b) After treatment.	a) 30 kV (rms) b) 60 kV (rms)
10	Dielectric dissipation factor (Tan-delta) at 90°C	0.002 (Max.)
11	Water content)Max.)	50 ppm
12	Specific resistance (resistivity) a) 90°C (Min.) b) At 27°C (Min.)	At b) a) 35x10 ohm-cm 900 x1 0 ohm-cm
13	Oxidation stability a) Neutralization value after oxidation (max.) b) Total sludge after oxidation (Max.)	0.40 mg KOH/gm 0.10% by weight

S.No.	Characteristics	Requirement
14	Ageing characteristics after accelerated ageing (open breaker method with copper catalyst)	2.5 x 10 ohm-cm
	a) Specific resistance (Resistivity) i) At 27°C (Min.) ii) At 90°C (Min.) b) Dielectric dissipation factor (Tan delta) at 90°C c) Total acidity (Max.)	0.2 x 10 ohm-cm
	d) Total sludge value percent by weight	0.2 Max. 0.05 mg KOH/gm 0.05 Max
15	Presence of oxidation inhibitor	Absent

B. CHARACTERISTICS OF OIL IN THE TRANSFORMERS

The important characteristics of the transformer oil after it is filled in the transformer (within 3 months of filling) shall be as follows:-

Sr No	Characteristics	Permissible limit satisfactory for use
1	Electric Strength (Breakdown kV) Prior to energisation	voltage 50 kV minimum
2	Water content (PPM)	25 PPM (max.)
3	Specific resistance (Resistivity) ohm-cm at 90°C	2X10 ohm-cm (Min)
4	Dielectric dissipation factor tan delta) at 90°C	0.01 (Max)
5	Neutralization value (Total acidity)	0.055 mg. KOH/gm (Max)
6	Sediment and/or perceptible sludge	Absent
7	Flash point	140°C (Min)
8	Interfacial tension at 27°C	0.030 N/m(Min).

40.1. TECHNICAL SPECIFICATION FOR L.T. XLPE POWER CABLE (armoured) FOR DISTRIBUTION NETWORK

40.2. Scope :

The specification covers design, manufacturing, testing, packing, supply & delivery on FOR destination basis of 1100 volts grade, LT Cable, multiple core, Cross linked Polyethylene (XLPE), FRLs, insulated, PVC sheathed, armoured power cables for effectively earthed systems.

40.3. Standards:

Unless otherwise specified, the cable shall conform in all respects to IS 7098-Part-1 (1988), IS 8130-1984, IEC:60502, IS 5831-1984, IS 10810-1984, IS 3975-1999 and IS 10418 – 1982 standards with latest amendments thereof.

40.4. Climatic conditions:

SNo.	Location	Haryana
1	Maximum ambient air temperature	50 deg C
2	Minimum ambient air temperature	(-) 5 deg C
3	Average daily maximum ambient temperature	40 deg C
4	Max yearly weighted average ambient temperature	32 deg C
5	Isoceraunic level	45 Days/year
6	Maximum altitude above mean sea level	1000 metres
7	Minimum relative humidity	26%
8	Max. relative humidity	100%
9	Average no of rainy days/year	120
10	Basic Wind Speed	47 M/S
11	Avg. Annual rainfall	900 mm
12	Pollution	Moderate
13	Maximum wind pressure	195 kg/m sq
14	Sesimic Zone	Zone-IV, III, II

Note : Moderately hot & humid tropical climate is conducive to rust & fungus growth. The climatic conditions are also prone to wide variations in ambient conditions. Smoke is also present in the atmosphere. Heavy lightning also occurs during June to October.

40.5. Design, construction and technical parameters: Conductor

The conductor of the cable shall be made from high conductivity, Electrolytic, H4 Grade, stranded aluminium to form compacted and circular/shaped conductor having resistance within limits as specified in IS 8130/1984 with latest amendments. The aluminium conductor shall be of class-2 as per IS 8130.

40.6. Insulation

- a. The insulation shall be suitable for LT system voltage and the insulating material shall be cross linked Poly Ethylene (XLPE), and applied by extrusion process as per IS 7098 Part-1 and its latest amendments. The insulation shall be an extrusion of thermosetting cross-linked polyethylene rated for 90°C continuous operation.
- b. The insulating material shall have excellent electrical properties with regard to resistivity, dielectric constant and loss factor and shall have high tensile strength and resistance to abrasion. This shall not deteriorate at elevated temperatures or when immersed in water. The insulation shall be preferably fire resistant and resistant to chemicals like acids, alkalis, oils and ozone.

- c. The insulation properties shall be stable under thermal conditions arising out of continuous operation at conductor temperature of 90°C rising momentarily to 250°C under short circuit conditions. It shall be free from any foreign material or porosity visible to the unaided eye. The insulation shall be so applied that it fits closely on the conductor and it shall be possible to remove it without damaging the conductor.
- d. The average thickness of insulation shall not be less than the nominal value as specified in IS:7098(Part I) with latest amendments.
- e. Tolerance on insulation thickness shall be as per IS-7098 Part-I. The insulation shall withstand mechanical and thermal stress under both steady state and transient operating conditions.

40.7. Core identification (for multiple core cables):

Individual core of multi-core cables shall be colour coded and/or numbered for proper identification in accordance with clause 10.1 of IS:7098 (Part-1)

40.8. Fillers and Laying up of cores (for multiple core cables):

In multi core cables, the cores shall be laid together with a suitable right hand lay. The interstices shall be filled with non-hygroscopic material. Further, the compounds used with fillers shall be such as to have no deleterious effect on other components of the cable and to be stable at cable temperatures.

40.9. Inner sheath (common covering):

- a. The laid up cores shall be provided with inner sheath applied by extrusion process. It shall be ensured that the shape is as circular as possible. It shall be applied to fit closely on the laid up cores and shall be possible to remove easily without causing any damage to the underlying insulated cores.
- b. The thickness of the inner sheath shall be as per (12.3) IS:7098 (Part-I). No tolerance on the negative side shall be acceptable.

40.10. Armoring:

The armour of cables shall consist of either galvanized round steel wires or galvanized steel strips as per clause 13.2 of IS:7098 (Part I). The armoring shall be applied such that the minimum area of coverage shall be 90% and the gap between any two armour strips/wire shall not be more than the width of strip/diameter of armour wire. The galvanized steel strips/wire shall comply with the requirements of IS:3975- with latest amendments. In case of Single core cable armoring shall be of Non-magnetic material conforming to IS:3975-1999 (amended upto date). The dimensions of the galvanized steel strip/wire shall be as per IS:7098 (Part-I) (Table -6, Clause 13.3, armoring size and dimension shall be as per method (b), method (a) is not acceptable) with latest amendments. No tolerance on the negative side shall be acceptable. Tolerance on size of armour shall be as per IS:7098 Part-1 & IS : 3975

40.11. Outer sheath:

- a. The outer sheath shall consist of extruded tough outer sheath of PVC compound insulation over the armoring. The PVC compound for the outer sheath shall conform to type ST-2 of IS:5831-1984 (amended up to date) with suitable additives (to prevent attacks by rodents and termites) shall be provided.
- b. The colour of the outer sheath shall be black. The cable must meet all the requirements of the IS:7098 (Part 1) amended up to date and shall bear ISI mark.

40.12. General:

- a. All materials used in manufacturing of cable shall be new, unused and of finest quality. All materials should comply with the requirements/tests as per applicable IS/IEC specification, Indian Electricity Rules and any other statutory provision of rules & regulations.

- b. The purchaser reserves the right to ask for documentary evidence of the purchase of various materials, (to be used for the manufacture of cable) as a part of quality control. Quality Assurance plan shall be submitted. Each of cable type and size shall be ISI certified. The manufacturer shall submit self-certified Xerox copy of valid ISI license with the offer.

40.13. Continuous Current rating:

As per Appendix-4

40.14. Short circuit Current rating:

As per Appendix -4

40.15. Operation:

- a. Cable shall be suitable for operation under voltage and frequency variation as per Latest Indian Electricity rule.
- b. Cable shall be suitable for laying in air, in duct or buried underground directly or through trenchless boring.
- c. Cable shall have heat & moisture resistance properties. These shall be of type & design with proven record on distribution network service.

40.16. Tests:

A. Type Tests:

- a. All the cable types and sizes i.e. items offered should have been fully type tested as per IS 7098 (Part-1) with amendments upto date at any NABL accredited Laboratory/Test house. If the manufacturer's lab is accredited by NABL then it shall be acceptable for typing test. The bidder shall furnish one set of authenticated copy of test reports along with the offer. These type tests must have been conducted within last five years prior to date of Bid opening. For any change between design/type of already type tested and the design/ type offered against this specification, the purchaser reserves the right to demand repetition of type tests without any extra cost. For each type and size the type test shall be got carried out independently.
 - b. The purchaser also reserves the right to have tests carried out at his own cost from an independent agency, whenever there is a dispute regarding the quality of supply.
 - c. The type test certificates type tests as per IS7098 part-1 shall be furnished invariably with the offer:
1. Tests on conductor:
 2. Tensile test
 3. Wrapping test
 4. Resistance test
 5. Tests for armouring strips/wires:
 6. Tests for thickness of insulation (eccentricity) and sheath
 7. Physical tests for insulation:
 8. Tensile strength and elongation at break.
 9. Ageing in air oven
 10. Hot set
 11. Shrinkage test
 12. Water absorption test (gravimetric)

13. Physical tests for outer sheath
 - (i) Tensile strength and elongation at break
 - (ii) Ageing in air oven
14. Shrinkage test
15. Hot deformation
16. Loss of mass in air oven
17. Heat Shock
18. Thermal stability
19. Carbon black content of polythene sheath.
20. Insulation resistance test (volume resistivity)
21. High voltage test
22. Flammability test
23. FRLS Tests-
 - (i) The following FRLS tests are to be conducted as per the referred standard
 - (ii) HCL gas evolution test (IEC- 754.1)
 - (iii) Oxygen Index (ASTM-D-2863)
 - (iv) Temperature Index (ASTM-D-2863)
 - (v) Smoke density test (ASTM-D-2863)
 - (vi) Flammability test (IEC – 332.1)
 - (vii) Swedish Chimney test (SS-424 1475)
 - (viii) Ladder Test (IEEE – 383)
 - (ix) The LT XLPE cables shall be routine tested as per relevant IEC/IS

B. The first lot offered shall not be less than 10% of ordered quantity of each size of LT XLPE ARMORED CABLE. One sample from the 1st Lot of LT XLPE ARMORED Cable of each size as received in purchaser's store shall be selected and sealed by the inspecting officer nominated by purchaser's for getting it type tested at any NABL accredited testing laboratory. The charges incurred towards type test of the material received in our store shall be borne by Supplier.

In case sample form first lot fails then:

- a. Supplier shall have to replace the full quantity of the respective inspected lot supplied to various stores and lying unused at stores.
- b. For the quantity already utilized against the order in field a deduction @15% (Fifteen Percent) of F.O.R. Destination prices of the material supplied shall be made.
- c. Sample from next lot shall be selected again for type test. All test charges incurred towards type test of the material for second time shall be borne by the Supplier. In case sample again fails in the type test then further supplies shall not be accepted.

C. ACCEPTANCE TEST:

The selection of sample pieces for acceptance test shall be as per Appendix A of IS 7098 (Part-I), of each lot offered for inspection or part thereof. The minimum shall be one drum. The g acceptance tests shall be carried as per IS:7098 (Part-I) out on the selected samples.

- (a) Tensile test (for aluminium)
- (b) Wrapping test (for aluminium)
- (c) Conductor resistance test
- (d) Test for thickness of insulation and sheath.
- (e) Hot set test for insulation
- (f) Tensile strength and elongation at break test for insulation and sheath.
- (g) High voltage test.
- (h) Insulation resistance (volume resistivity) test
 - (i) All the acceptance tests shall be carried out by the firm, in the presence of purchaser's representative at their works. The firm shall give at least 15 days advance notice to the purchaser to enable him to depute the engineer for witnessing the tests. The test certificates for acceptance tests witnessed by inspecting officer/engineer shall be submitted for approval before dispatch of material.
 - (ii) D. Routine Tests
 - (iii) The following shall constitute the routine tests. The Inspector may also inspect the routine tests at the time of inspection.
- (a) Conductor resistance test
- (b) High-voltage test for 5 minutes [as per Clause 16.2 of IS: 7098 (Part-1)

40.17. Quality Assurance Plan:

- a. A detailed list of bought out items which got into the manufacture of cables should be furnished indicating the name of the firms from whom these items are procured. The bidder shall enclose the quality assurance plan invariably along with offer followed by him in respect of the bought out items, items manufactured by him & raw materials in process as well as final inspection, packing & marking. The Company may at its option order the verification of these plans at manufacturer's works as a pre-qualification for technically accepting the bid.
- b. 17. Identification mark:
- c. The outer sheath of the cable shall bear following identification parameters embossed at intervals of length of one meter of cable, throughout the cable:-
 - i) Name of manufacturer
 - ii) Year of manufacture
 - iii) Voltage grade
 - iv) Size of cable
 - v) Cable code
 - vi) Name of purchaser "DHBVN"
 - vii) ISI Certification mark
 - viii) Successive length
 - ix) Marking for FRLS cable

40.18. Packing and Forwarding:

The cable shall be wound on non-returnable wooden drums as per IS:10418 -1972 and packed in drums suitable for vertical/horizontal transport, as the case may be and shall be suitable to withstand rough handling during transport and outer storage. The outer surface of the drum shall be painted with white aluminium paint. Similarly, the inside surface of drum shall have the protective layer of varnish/paint.

40.18.1.The wooden drums shall be reinforced with steel bends and strips for better protection.

40.18.2.Length: The cable shall be supplied in standard drum length as per detail below:

Size (Sq.mm)	1C(meter)	2C(meter)	3C(meter)	3.5C& 4C (meter)
0-up to 16	2000	1500	1000	1000
Above 16-up to 50	1500	1000	1000	1000
Above 50-up to 150	1000	750	750	750
Above 150-up to 300	750	500	500	500
Above 300	500	300	300	300

40.18.3.The ends of the cable shall be sealed by means of non-hygroscopic heat shrinkable sealing material.

40.18.4.The following information be stencilled on the drum with either water proof ink or oil paint:

- a. Reference of IS/IEC standard
- b. Manufacturer's name or trademark.
- c. Type of cable and voltage grade
- d. No of cores.
- e. Nominal cross-sectional area of conductor
- f. Cable code
- g. Length of cable on the drum
- h. Gross weight
- i. Direction of rotation of drum (by means of an arrow)
- j. Position of outer end of cable
- k. Nigam's technical specification number
- l. Year of manufacture
- m. Reference of Tender No./ P.O. No. date
- n. Property of "DHBVN"
- o. Name of consignee and the destination.
- p. ISI Certification Mark.

40.18.5.The firm shall be responsible for any damage to the cables during transit due to improper and inadequate packing. Wherever necessary, proper arrangement for lifting, such as lifting hooks, shall be provided. Any cable found short inside the packing cases shall be supplied by the supplier, without any extra cost.

40.18.6.Each consignment shall be accompanied by a detailed packing list, containing the following information:

- (a) Name of consignee
- (b) Details of consignment
- (c) Destination

- (d) Total weight of consignment
- (e) Handling and unpacking instruction
- (f) Bill of materials, indicating contents of each package.

40.19.INSPECTION:

40.19.1. The inspection may be carried out by the purchaser at any stage of manufacture. The successful bidder shall grant free access to the purchaser's representative at reasonable time, when the work is in progress. Inspection and acceptance, of any cables under this specification by the purchaser, shall not relieve the supplier of his obligation of supplying cable in accordance with the specification and shall not prevent subsequent rejection, if the cables are not found as per the technical specifications.

40.19.2. The supplier shall keep the purchaser informed in advance about the programme of manufacturing of cables so that arrangement can be made for inspection.

40.19.3. The purchaser reserves the right to insist for witnessing the acceptance / routine tests of the bought out items.

The manufacturer shall be responsible to pay penalty of Rs 20,000/- for each occasion at which the fake inspection call has been made or the material is rejected during testing/inspection by the authorized agency /representative of the Nigam. This penalty would be in addition to the expenses incurred by the Nigam in deputing the Inspecting Officer, carrying out such inspection.

40.19.4. At least 5% of total numbers of drums subject to minimum of 2 in each lot put up for inspection shall be selected at random to ascertain the length/workmanship of cable by the following method:

40.19.5. At the work of the manufacture, the cable shall be transferred from one drum to another for checking any manufacturing defects in the cable drum selected for conducting acceptance tests, at the same time measuring its length with the help of pulley & cyclometer graduated in presence of inspector. The difference in the measured length thus obtained from the declared length by the supplier in the packing list shall be applied to all the drums if the cable is found short during checking the sample lots.

40.19.6. The supplier shall present the latest Calibration Certificate(s) of testing instruments/equipments to be used for the testing of the material covered in the Purchase Order to the authorized inspecting officer/inspecting agency of the purchaser. The testing instruments/meters/apparatus etc. should be got calibrated by the supplier from time to time from an independent testing laboratory/ house having valid accreditation from National Accreditation Board for testing and calibrating laboratories for the testing equipment or from original manufacturers having traceability to NABL/NPL. The calibration certificate(s) should not in any case be older than one year at the time of presenting the same to the inspecting officer / inspecting agency of the purchaser. The testing instruments/equipment should be duly sealed by the Calibrating Agency and mention thereof shall be indicated in the calibration certificate (s).

40.20. DOCUMENTATION:

40.20.1. The bidder shall furnish following documents along with this offer- Sectional view, showing the General constructional feature with conductor/conductor screen / insulation / armouring / inner and outer sheath etc.

40.20.2. Drawing of cable drums with details of material dimension and paint etc.

40.20.3. All the required type test reports.

40.20.4. Literature, pamphlets for the supplied items.

40.21. TECHNICAL AND GUARANTEED PARTICULARS:

The bidder shall furnish all Guaranteed Technical Particulars, as called for, in Appendix-5 of this Specification. Particulars, which are subject to guarantee, shall be clearly identified. Offer not containing these information will not be considered for acceptance.

40.22. CHALLENGE CLAUSE:-

The material offered/received after the inspection by the authorized inspecting officer may again be subjected to test for any parameter from any testing house/in-house technique of the Nigam & the results if found deviating/un-acceptable or not complying to Technical specification, the bidder shall arrange to supply the replacement within thirty (30) days of such detection at his cost including to & fro transportation. In addition, penalty @10% of cost of the inspected lot of material shall be imposed.

40.23. WARRANTY PERIOD:

The supplier shall be responsible to replace, free of cost, with no transportation or insurance cost to the purchaser, up to destination, the whole or any part to the material which in normal and proper use proved as defective in quality or workmanship, subject to the condition that the defect is noticed within 72 months from the date of commissioning. The consignee or any other officer of Nigam actually using the material will give prompt notice of each such defect to the supplier. The replacement shall be effected by the supplier within a reasonable time, but not, in any case, exceeding 45 days. The supplier shall, also arrange to remove the defective material within a reasonable period, but not exceeding 45 days from the date of issue of notice in respect thereof, failing which, the purchaser reserve the right to dispose of the defective material in any manner considered fit by him (purchaser), at the sole risk and cost of the supplier. Any sale proceeds of the defective material after meeting the expenses incurred on its custody, disposal handling etc., shall however be credited to the supplier's account and set off against any outstanding dues of the purchaser against the supplier. The warranty shall be for the entire duration of the warranty period.

40.24. NIGAM'S QUALITY ASSURANCE PLAN:-

The Nigam's Quality assurance plan for the inspection of material at manufacturer's factory, post receipt inspection at Nigam's stores/turnkey contractor's site stores, dispatch of material, supply lots, counter checking etc is in force for the procurement and turnkey works which will be applicable, as the case may be, along with up to date amendments, if any.

Appendix –4

1100V Single Core, two core, three Core, 3.5 Core and four core, XLPE insulated unarmoured Power Cables with aluminium conductor for earthed systems:-

1. Continuous current rating :-

Nominal cross sectional area of conductor (sq mm)	Continuous current rating for Three core cables (Amps)		Continuous current rating for single core cables (amps)		Continuous current rating for two core cables (amps)	
	In ground	In air	In ground	In air	In ground	In air
10	57	53	59	57	57	53
16	78	70	76	73	78	70
35	116	117	117	140	116	117
50	140	140	138	170	140	140
95	200	221	204	255	200	221
120	225	258	230	300	225	258
150	255	294	265	342	255	294
185	285	339	295	385	285	339
240	325	402	340	450	325	402
300	370	460	390	519	370	461
400	435	542	450	605	435	542
500	481	624	500	700	481	624
630	537	723	555	809	537	723

Nominal cross sectional area of conductor (sq mm)	Continuous current rating for 3.5 core cables (Amps)		Continuous current rating for 4C core cables (amps)	
	In ground	In air	In ground	In air
16	-	-	78	70
25	95	99	95	99
35	116	117	116	117
50	140	140	140	140
95	200	221	200	221
120	225	258	225	258
150	255	294	255	294
185	285	339	285	339
240	325	402	325	402
300	370	461	370	460
400	435	542	435	542
500	481	624	481	624
630	537	723	537	723

Depth of laying: 900 mm; Ambient Air temp: 40 deg C; Ground Temp: 30 deg C; Thermal resistivity of soil : 150 deg C cm/w.

While designing overall system suitable derating factor shall be taken in to account as per the site condition.

2. Single core armoured cables - dimensional details as per IS 7098 (Part –I)

Nominal area of conductor (sq mm)	Nominal thickness of insulation (mm)	Nominal thickness of outer sheath (mm)
35	1.2	1.24

Nominal area of conductor (sq mm)	Nominal thickness of insulation (mm)	Nominal thickness of outer sheath (mm)
50	1.3	1.24
95	1.4	1.40
120	1.5	1.40
150	1.7	1.40
185	1.9	1.40
240	2.0	1.40
300	2.2	1.56
400	2.4	1.56
500	2.6	1.56
630	2.8	1.72

4 Two core armoured cables – dimensional details as per IS 7098 (Part -1)

Nominal area of conductor (sq mm)	Nominal thickness of insulation (mm)	Minimum thickness of inner sheath (mm)	Nominal thickness of outer sheath (mm)
10	0.70	0.3	1.24
16	0.70	0.3	1.40
35	0.90	0.3	1.40
50	1.00	0.3	1.40
95	1.10	0.4	1.56
120	1.20	0.4	1.56
150	1.40	0.5	1.72
185	1.60	0.5	1.88
240	1.70	0.5	2.04
300	1.80	0.6	2.20
400	2.00	0.7	2.36
500	2.20	0.7	2.68
630	2.40	0.7	2.84

2 Three core armoured cables – dimensional details as per IS 7098 (Part -1)

Nominal area of conductor (sq mm)	Nominal thickness of insulation (mm)	Minimum thickness of inner sheath (mm)	Nominal thickness of outer sheath (mm)
35	0.90	0.3	1.40
50	1.00	0.3	1.40
95	1.10	0.4	1.56
120	1.20	0.4	1.56
150	1.40	0.5	1.72
185	1.60	0.5	1.88
240	1.70	0.6	2.20
300	1.80	0.6	2.20
400	2.00	0.7	2.52
500	2.20	0.7	2.68
630	2.40	0.7	2.84

3 Three and Half core armoured cables

Nominal area of conductor (sq mm)	Nominal thickness of insulation (mm)	Minimum thickness of inner sheath (mm)	Nominal thickness of outer sheath (mm)
-----------------------------------	--------------------------------------	--	--

35	0.90	0.3	1.40
50	1.00	0.3	1.40
95	1.10	0.4	1.56
120	1.20	0.4	1.72
150	1.40	0.5	1.72
185	1.60	0.5	1.88
240	1.70	0.6	2.20
300	1.80	0.6	2.20
400	2.00	0.7	2.52
500	2.20	0.7	2.68
630	2.40	0.7	3.00

4 Four core armoured cables

Nominal area of conductor (sq mm)	Nominal thickness of insulation (mm)	Minimum thickness of inner sheath (mm)	Nominal thickness of outer sheath (mm)
16	0.70	0.3	1.40
25	0.90	0.3	1.40
35	0.90	0.3	1.40
50	1.00	0.3	1.40
95	1.10	0.4	1.56
120	1.20	0.5	1.72
150	1.40	0.5	1.88
185	1.60	0.5	2.04
240	1.70	0.6	2.36
300	1.80	0.7	2.36
400	2.00	0.7	2.68
500	2.20	0.7	2.84
630	2.40	0.7	3.00

39. Conductor resistance and Short Circuit Current Capacity (common for IC and 3C & 3.5C)

Nominal area of conductor (sq mm)	Maximum DC resistance at 20 deg C (Ohms/km)	Short Circuit current for conductor (KA/sec)
25	1.20	2.35
35	.8680	3.29
50	.6410	4.70
95	.3200	8.93
120	.2530	11.28
150	.2060	14.10
185	.1640	17.39
240	.1250	22.56
300	.1000	28.20
400	.0778	37.60
500	.0605	47.00
630	.0469	59.22

Appendix –5

GUARANTEED TECHNICAL AND OTHER PARTICULARS FOR THE SUPPLY OF MULTIPLE CORE LT XLPE UNARMoured CABLES

S.No	PARTICULARS		MULTIPLE CORE XLPE UNARMoured CABLES IN SIZE
			SIZE
1	Manufacturer's name and work address		
2	Standard specification to which the material shall		
3	VOLTAGE GRADE		
4	NO OF CORES		
5	CONDUCTOR DETAILS:		
	A	Normal cross section area of :	
		1 Phase Conductor (Sq.mm)	
		2 Neutral Conductor (Sq.mm)	
	B	No and size of strands (in mm) of	
		1 Phase Conductor (Sq.mm)	
		2 Neutral Conductor (Sq.mm)	
	C	SHAPE OF CONDUCTOR	
	D	Whether compacted or non compacted	
	E	Resistance at 27 °c	
		1 Phase Conductor ohm/km	
		2 Neutral Conductor ohm/km	
6	INSULATION		
	1	TYPE	
	2	Colour	
	3	Thickness	
	A	Phase Conductor (sq.mm)	
		1 Nominal (mm)	
		2 Minimum (mm)	
	B	Neutral Conductor (Sq.mm)	
		1 Nominal (mm)	
		2 Minimum (mm)	
7	Type of inner sheathing and colour		
8	Whether Binder Tape provided		
9	ARMoring		
	A	Type	
	B	Dimension (mm)	
10	Outer Sheath		
	A	Material	
	B	Thickness	
		1 Nominal (mm)	
		2 Minimum (mm)	
	C	Standard to which it Confirm	
11	A	Type and size of filler used	
	B	MIN. WT. OF FILLER IN KG./KM	
12	MAX. OVERALL DIAMETER OF THE CABLE IN MM		
13	Nature of Packing		
14	DRUM		
	A	TARE WEIGHT OF DRUM	
	B	WHETHER DRUM IS WHELL	
	C	STANDARD SPECIFICATION TO WHICH	
	D	DRUM DETAILS & DIMENSIONS	

S.No	PARTICULARS	MULTIPLE CORE XLPE UNARMoured CABLES IN
	E Whether 2-Full Ply Flange Construction or 2-Full Ply plus 1 Segmental layer Flange Construction.	
	1 Drum size	
	A Flange Diameter (d1) (mm)	
	B Barrel Diameter (d2) (mm)	
	C Centre hole Diameter (d3) (mm)	
	D Overall with (L1) (mm)	
	E Travers (L2) (mm)	
	G Thickness of Flange	
	H Barrel End (Supporting disc or	
	1 Diameter (mm)	
	2 Thickness (mm)	
	I Stretchers (core carrier Planks)	
	1 Number (Min)	
	2 Thickness x width (mm)	
	J Barrel Battens thickness	
	K Barrel Middle supports	
	L Thickness of External Lagging	
	2 DETAILS OF METAL	
	A Clamping Studs with	
	1 Numbers	
	2 Diameter (mm)	
	B Square or Round Washers	
	1 Numbers	
	2 Diameter (mm)	
	M.S. Bushes	
	1 Numbers	
	2 Thickness of Sleeve (mm)	
	3 Dimension of Sleeve (mm)	
	4 Number of Bolts	
	5 Diameter of Bolts	
	D M.S./C.I. Centre Plate	
	1 Numbers	
	2 Diameter of Bolts (mm)	
	3 Centre Plate Bolts	
	4 A Numbers	
	B Diameter of Bolts	
	E Centre Hole Diameter (mm)	
	F Minimum Weight in Kh/km	
	G Standard Length of cable in metre & its Tolerance	
	H Whether material bears BIS Certification	
	I BIS License No & Validity	
	J Embossing	
	K Any other particulars.	

41.1. TECHNICAL SPECIFICATION FOR L.T. XLPE POWER CABLE (unarmoured) FOR DISTRIBUTION NETWORK

1. Scope :

The specification covers design, manufacturing, testing, packing, supply & delivery on FOR destination basis of 1100 volts grade, LT Cable, multiple core, Cross linked Polyethylene (XLPE), FRLs, insulated, PVC sheathed, unarmoured power cables for effectively earthed systems.

2. Standards:

Unless otherwise specified, the cable shall conform in all respects to IS 7098-Part-1 (1988), IS 8130-1984, IEC:60502, IS 5831-1984, IS 10810-1984, IS 3975-1999 and IS 10418 – 1982 standards with latest amendments thereof.

3. Climatic conditions:

1	Location	Haryana
2	Maximum ambient air temperature	50 deg C
3	Minimum ambient air temperature	(-) 5 deg C
4	Average daily maximum ambient temperature	40 deg C
5	Max yearly weighted average ambient temperature	32 deg C
6	Isoceraunic level	45 Days/year
7	Maximum altitude above mean sea level	1000 metres
8	Minimum relative humidity	26%
9	Max. relative humidity	100%
10.	Average no of rainy days/year	120
11.	Basic Wind Speed	47 M/S
12.	Avg. Annual rainfall	900 mm
13.	Pollution	Moderate
14.	Maximum wind pressure	195 kg/m sq
15.	Sesimic Zone	Zone-IV, III, II

Note : Moderately hot & humid tropical climate is conducive to rust & fungus growth. The climatic conditions are also prone to wide variations in ambient conditions. Smoke is also present in the atmosphere. Heavy lightning also occurs during June to October.

4. Design, construction and technical parameters : Conductor

The conductor of the cable shall be made from high conductivity, Electrolytic, H4 Grade, stranded aluminium to form compacted and circular/shaped conductor having resistance within limits as specified in IS 8130/1984 with latest amendments. The aluminium conductor shall be of class-2 as per IS 8130.

5. Insulation

The insulation shall be suitable for LT system voltage and the insulating material shall be cross linked Poly Ethylene (XLPE), and applied by extrusion process as per IS 7098 Part-1 and its latest amendments. The insulation shall be an extrusion of thermosetting cross-linked polyethylene rated for 90°C continuous operation.

The insulating material shall have excellent electrical properties with regard to resistivity, dielectric constant and loss factor and shall have high tensile strength and resistance to abrasion. This shall not deteriorate at elevated temperatures or when immersed in water. The insulation shall be preferably fire resistant and resistant to chemicals like acids, alkalis, oils and ozone.

The insulation properties shall be stable under thermal conditions arising out of continuous operation at conductor temperature of 90°C rising momentarily to 250°C under short circuit conditions. It shall be free from any foreign material or porosity visible to the unaided eye. The insulation shall be so applied that it fits closely on the conductor and it shall be possible to remove it without damaging the conductor.

The average thickness of insulation shall not be less than the nominal value as specified in IS:7098(Part I) with latest amendments.

Tolerance on insulation thickness shall be as per IS-7098 Part-I. The insulation shall withstand mechanical and thermal stress under both steady state and transient operating conditions.

6. Core identification (for multiple core cables):

Individual core of multi-core cables shall be colour coded and/or numbered for proper identification in accordance with clause 10.1 of IS:7098 (Part-1)

7. Fillers and Laying up of cores (for multiple core cables):

In multi core cables, the cores shall be laid together with a suitable right hand lay. The interstices shall be filled with non-hygroscopic material. Further, the compounds used with fillers shall be such as to have no deleterious effect on other components of the cable and to be stable at cable temperatures.

8. Inner sheath (common covering):

The laid up cores shall be provided with inner sheath applied by extrusion process. It shall be ensured that the shape is as circular as possible. It shall be applied to fit closely on the laid up cores and shall be possible to remove easily without causing any damage to the underlying insulated cores.

The thickness of the inner sheath shall be as per (12.3) IS:7098 (Part-I). No tolerance on the negative side shall be acceptable.

9. Outer sheath:

The outer sheath shall consist of extruded tough outer sheath of PVC compound insulation. The PVC compound for the outer sheath shall conform to type ST-2 of IS:5831-1984 (amended up to date) with suitable additives (to prevent attacks by rodents and termites) shall be provided. The colour of the outer sheath shall be black. The cable must meet all the requirements of the IS:7098 (Part 1) amended up to date and shall bear ISI mark.

10. General:

All materials used in manufacturing of cable shall be new, unused and of finest quality. All materials should comply with the requirements/tests as per applicable IS/IEC specification, Indian Electricity Rules and any other statutory provision of rules & regulations. The purchaser reserves the right to ask

for documentary evidence of the purchase of various materials, (to be used for the manufacture of cable) as a part of quality control. Quality Assurance plan shall be submitted. Each of cable type and size shall be ISI certified. The manufacturer shall submit self certified Xerox copy of valid ISI license with the offer.

11. Continuous Current rating:

As per Appendix-6

12. Short circuit Current rating:

As per Appendix -6

13. Operation:

- i) Cable shall be suitable for operation under voltage and frequency variation as per Latest Indian Electricity rule.
- ii) Cable shall be suitable for laying in air, in duct or buried underground directly or through trenchless boring.
- iii) Cable shall have heat & moisture resistance properties. These shall be of type & design with proven record on distribution network service.

14. Tests:

D. Type Tests:

All the cable types and sizes i.e. items offered should have been fully type tested as per IS 7098 (Part-1) with amendments upto date at any NABL accredited Laboratory/Test house. If the manufacturer's lab is accredited by NABL then it shall be acceptable for typing test. The bidder shall furnish one set of authenticated copy of test reports along with the offer. These type tests must have been conducted within last five years prior to date of Bid opening. For any change between design/type of already type tested and the design/ type offered against this specification, the purchaser reserves the right to demand repetition of type tests without any extra cost. For each type and size the type test shall be got carried out independently.

The purchaser also reserves the right to have tests carried out at his own cost from an independent agency, whenever there is a dispute regarding the quality of supply.

The type test certificates type tests as per IS7098 part-1 shall be furnished invariably with the offer:

- (a) Tests on conductor:
 - (i) Tensile test
 - (ii) Wrapping test

(iii) Resistance test

(b) Tests for thickness of insulation (eccentricity) and sheath

(c) Physical tests for insulation:

(i) Tensile strength and elongation at break.

(ii) Ageing in air oven

(iii) Shrinkage test

(iv) Hot deformation

(v) Loss of mass in air oven

(vi) Heat Shock

All the acceptance tests shall be carried out by the firm, in the presence of purchaser's representative at their works. The firm shall give atleast 15 days advance notice to the purchaser to enable him to depute the engineer for witnessing the tests. The test certificates for acceptance tests witnessed by inspecting officer/engineer shall be submitted for approval before dispatch of material.

D. Routine Tests

The following shall constitute the routine tests. The Inspector may also inspect the routine tests at the time of inspection.

(c) Conductor resistance test

(d) High-voltage test for 5 minutes [as per Clause 16.2 of IS: 7098 (Part-1)

15) Quality Assurance Plan:

A detailed list of bought out items which got into the manufacture of cables should be furnished indicating the name of the firms from whom these items are procured. The bidder shall enclose the quality assurance plan invariably along with offer followed by him in respect of the bought out items, items manufactured by him & raw materials in process as well as final inspection, packing & marking. The Company may at its option order the verification of these plans at manufacturer's works as a pre-qualification for technically accepting the bid.

16. Identification mark:

The outer sheath of the cable shall bear following identification parameters embossed at intervals of length of one meter of cable, throughout the cable:-

- a. Name of manufacturer
- b. Year of manufacture
- c. Voltage grade
- d. Size of cable
- e. Cable code
- f. Name of purchaser “DHBVN”
- g. ISI Certification mark
- h. Successive length
- i. Marking for FRLS cable

17.Packing and Forwarding:

17.1 The cable shall be wound on non-returnable wooden drums as per IS:10418 -1972 and packed in drums suitable for vertical/horizontal transport, as the case may be and shall be suitable to withstand rough handling during transport and outer storage. The outer surface of the drum shall be painted with white aluminium paint. Similarly, the inside surface of drum shall have the protective layer of varnish/paint.

17.2 The wooden drums shall be reinforced with steel bends and strips for better protection.

17.3 Length: The cable shall be supplied in standard drum length as per detail below:

Size (Sq.mm)	1C(meter)	2C(meter)	3C(meter)	3.5C& 4C (meter)
0-up to 16	2000	1500	1000	1000
Above 16-up to 50	1500	1000	1000	1000
Above 50-up to 150	1000	750	750	750
Above 150-up to 300	750	500	500	500
Above 300	500	300	300	300

17.3.1 The ends of the cable shall be sealed by means of non-hygroscopic heat shrinkable sealing material.

17.4 The following information be stencilled on the drum with either water proof ink or oil paint:

- a. Reference of IS/IEC standard
- b. Manufacturer’s name or trademark.
- c. Type of cable and voltage grade
- d. No of cores.
- e. Nominal cross-sectional area of conductor
- f. Cable code
- g. Length of cable on the drum
- h. Gross weight
- i. Direction of rotation of drum (by means of an arrow)
- j. Position of outer end of cable
- k. Nigam’s technical specification number
- l. Year of manufacture
- m. Reference of Tender No./ P.O. No. date
- n. Property of “DHBVN”

- o. Name of consignee and the destination.
- p. ISI Certification Mark.

17.5 The firm shall be responsible for any damage to the cables during transit due to improper and inadequate packing. Wherever necessary, proper arrangement for lifting, such as lifting hooks, shall be provided. Any cable found short inside the packing cases shall be supplied by the supplier, without any extra cost.

17.6 Each consignment shall be accompanied by a detailed packing list, containing the following information:

- (g) Name of consignee
- (h) Details of consignment
- (i) Destination
- (j) Total weight of consignment
- (k) Handling and unpacking instruction
- (l) Bill of materials, indicating contents of each package.

18 Inspection:

18.1 The inspection may be carried out by the purchaser at any stage of manufacture. The successful bidder shall grant free access to the purchaser's representative at reasonable time, when the work is in progress. Inspection and acceptance, of any cables under this specification by the purchaser, shall not relieve the supplier of his obligation of supplying cable in accordance with the specification and shall not prevent subsequent rejection, if the cables are not found as per the technical specifications.

18.2 The supplier shall keep the purchaser informed in advance about the programme of manufacturing of cables so that arrangement can be made for inspection.

18.2.1 The purchaser reserves the right to insist for witnessing the acceptance / routine tests of the bought out items.

The manufacturer shall be responsible to pay penalty of Rs 20,000/- for each occasion at which the fake inspection call has been made or the material is rejected during testing/inspection by the authorized agency /representative of the Nigam. This penalty would be in addition to the expenses incurred by the Nigam in deputing the Inspecting Officer, carrying out such inspection.

18.2.2 At least 5% of total numbers of drums subject to minimum of 2 in each lot put up for inspection shall be selected at random to ascertain the length/workmanship of cable by the following method:

18.3 At the work of the manufacture, the cable shall be transferred from one drum to another for checking any manufacturing defects in the cable drum selected for conducting acceptance tests, at the same time measuring its length with the help of pulley & cyclometer graduated in presence of inspector. The difference in the measured length thus obtained from the declared length by the supplier in the packing list shall be applied to all the drums if the cable is found short during checking the sample lots).

The supplier shall present the latest Calibration Certificate(s) of testing instruments/equipments to be used for the testing of the material covered in the Purchase Order to the authorized inspecting officer/inspecting agency of the purchaser. The testing instruments/meters/apparatus etc. should be got calibrated by the supplier from time to time from an independent testing laboratory/ house having valid accreditation from National Accreditation Board for testing and calibrating laboratories for the testing equipment or from original manufacturers having traceability to NABL/NPL. The calibration certificate(s) should not in any

case be older than one year at the time of presenting the same to the inspecting officer / inspecting agency of the purchaser. The testing instruments/equipment should be duly sealed by the Calibrating Agency and mention thereof shall be indicated in the calibration certificate (s).

19 Documentation:

19.1 The bidder shall furnish following documents along with this offer- Sectional view, showing the General constructional feature with conductor/conductor screen / insulation / armouring / inner and outer sheath etc.

19.2 Drawing of cable drums with details of material dimension and paint etc.

19.3 All the required type test reports.

19.4 Literature, pamphlets for the supplied items.

20 Technical and guaranteed particulars:

The bidder shall furnish all Guaranteed Technical Particulars, as called for, in Appendix-7 of this Specification. Particulars, which are subject to guarantee, shall be clearly identified. Offer not containing these information will not be considered for acceptance.

21 Challenge Clause:-

The material offered/received after the inspection by the authorized inspecting officer may again be subjected to test for any parameter from any testing house/in-house technique of the Nigam & the results if found deviating/un-acceptable or not complying to Technical specification, the bidder shall arrange to supply the replacement within thirty (30) days of such detection at his cost including to & fro transportation. In addition, penalty @10% of cost of the inspected lot of material shall be imposed.

22 Warranty Period:

The supplier shall be responsible to replace, free of cost, with no transportation or insurance cost to the purchaser, up to destination, the whole or any part to the material which in normal and proper use proved as defective in quality or workmanship, subject to the condition that the defect is noticed within 72 months from the date of commissioning. The consignee or any other officer of Nigam actually using the material will give prompt notice of each such defect to the supplier. The replacement shall be effected by the supplier within a reasonable time, but not, in any case, exceeding 45 days. The supplier shall, also arrange to remove the defective material within a reasonable period, but not exceeding 45 days from the date of issue of notice in respect thereof, failing which, the purchaser reserve the right to dispose of the defective material in any manner considered fit by him (purchaser), at the sole risk and cost of the supplier. Any sale proceeds of the defective material after meeting the expenses incurred on its custody, disposal handling etc., shall however be credited to the supplier's account and set off against any outstanding dues of the purchaser against the supplier. The warranty shall be for the entire duration of the warranty period.

23 Nigam's Quality Assurance Plan:-

The Nigam's Quality assurance plan for the inspection of material at manufacturer's factory, post receipt inspection at Nigam's stores/turnkey contractor's site stores, dispatch of material, supply lots, counter checking etc is in force for the procurement and turnkey works which will be applicable, as the case may be, along with up to date amendments, if any.

Appendix –6

1100V Single Core, two core, three Core, 3.5 Core and four core, XLPE insulated unarmoured Power Cables with aluminium conductor for earthed systems:-

3. Continuous current rating :-

Nominal cross sectional area of conductor (sq mm)	Continuous current rating for Three core cables (Amps)		Continuous current rating for single core cables (amps)		Continuous current rating for two core cables (amps)	
	In ground	In air	In ground	In air	In ground	In air
10	57	53	62	61	57	53
16	78	70	81	83	78	70
35	116	117	117	140	140	140
50	140	140	138	170	140	140
95	200	221	204	255	200	221
120	225	258	230	300	225	258
150	255	294	265	342	255	294
185	285	339	295	385	285	339
240	325	402	340	450	325	402
300	370	460	390	519	370	461
400	435	542	450	605	435	542
500	481	624	500	700	481	624
630	537	723	555	809	537	723

Nominal cross sectional area of conductor (sq mm)	Continuous current rating for 3.5 core cables (Amps)		Continuous current rating for 4C core cables (amps)	
	In ground	In air	In ground	In air
16	-	-	78	70
25	95	99	95	99
35	116	117	116	117
50	140	140	140	140
95	200	221	200	221
120	225	258	225	258
150	255	294	255	294
185	285	339	285	339
240	325	402	325	402
300	370	461	370	460
400	435	542	435	542
500	481	624	481	624
630	537	723	537	723

Depth of laying: 900 mm; Ambient Air temp: 40 deg C; Ground Temp: 30 deg C; Thermal resistivity of soil : 150 deg C cm/w.

While designing overall system suitable derating factor shall be taken in to account as per the site condition.

4. Single core cables (unarmoured) - dimensional details as per IS 7098 (Part –I)

Nominal area of conductor (sq mm)	Nominal thickness of insulation (mm)	Nominal thickness of outer sheath (mm)
10	0.7	1.8
16	0.7	1.8
25	0.9	1.8
35	0.9	1.8
50	1.0	1.8
95	1.1	1.8
120	1.2	1.8
150	1.4	2.0
185	1.6	2.0
240	1.7	2.0
300	1.8	2.0
400	2.0	2.2
500	2.2	2.2
630	2.4	2.2

2 Two core cables (unarmoured) – dimensional details as per IS 7098 (Part -1)

Nominal area of conductor (sq mm)	Nominal thickness of insulation (mm)	Minimum thickness of inner sheath (mm)	Nominal thickness of outer sheath (mm)
10	0.7	0.3	1.8
16	0.7	0.3	1.8
35	0.90	0.3	2.0
50	1.00	0.3	2.0
95	1.10	0.4	2.2
120	1.20	0.4	2.2
150	1.40	0.4	2.2
185	1.60	0.5	2.4
240	1.70	0.5	2.6
300	1.80	0.6	2.8
400	2.00	0.6	3.0
500	2.20	0.7	3.4
630	2.40	0.7	3.6

3 Three core cables (unarmoured) – dimensional details as per IS 7098 (Part -1)

Nominal area of conductor (sq mm)	Nominal thickness of insulation (mm)	Minimum thickness of inner sheath (mm)	Nominal thickness of outer sheath (mm)
10	0.7	0.3	1.80
16	0.7	0.3	1.80
25	0.90	0.3	2.0
35	0.90	0.3	2.0
50	1.00	0.3	2.0
95	1.10	0.4	2.2
120	1.20	0.4	2.2
150	1.40	0.5	2.4
185	1.60	0.5	2.6
240	1.70	0.6	2.8
300	1.80	0.6	3.0
400	2.00	0.6	3.2
500	2.20	0.7	3.6
630	2.40	0.7	3.8

4 Three and Half core (unarmoured) cables

Nominal area of conductor (sq mm)	Nominal thickness of insulation (mm)	Minimum thickness of inner sheath (mm)	Nominal thickness of outer sheath (mm)
25	0.90	0.3	2.0
35	0.90	0.3	2.0
50	1.00	0.3	2.0
95	1.10	0.4	2.2
120	1.20	0.4	2.2
150	1.40	0.5	2.4
185	1.60	0.5	2.6
240	1.70	0.6	2.8
300	1.80	0.6	3.0
400	2.00	0.7	3.4
500	2.20	0.7	3.6
630	2.40	0.7	4.0

3 Four core unarmoured cables

Nominal area of conductor (sq mm)	Nominal thickness of insulation (mm)	Minimum thickness of inner sheath (mm)	Nominal thickness of outer sheath (mm)
10	.70	0.3	1.8
16	.70	0.3	1.8
25	.90	0.3	2.0
35	.90	0.3	2.0
50	1.00	0.3	2.0
95	1.10	0.4	2.2
120	1.20	0.5	2.4
150	1.40	0.5	2.6
185	1.60	0.5	2.8
240	1.70	0.6	3.0
300	1.80	0.7	3.2
400	2.00	0.7	3.6
500	2.20	0.7	3.8
630	2.40	0.7	4.0

40. Conductor resistance and Short Circuit Current Capacity (common for IC and 3C & 3.5C)

Nominal area of conductor (sq mm)	Maximum DC resistance at 20 deg C (Ohms/km)	Short Circuit current for conductor (KA/sec)
25		2.35
35	.8680	3.29
50	.6410	4.70
95	.3200	8.93
120	.2530	11.28
150	.2060	14.10
185	.1640	17.39
240	.1250	22.56
300	.1000	28.20
400	.0778	37.60
500	.0605	47.00
630	.0469	59.22

Appendix -7

**GUARANTEED TECHNICAL AND OTHER PARTICULARS FOR THE SUPPLY OF
MULTIPLE CORE LT XLPE UNARMoured CABLES**

S.No	PARTICULARS		MULTIPLE CORE XLPE UNARMoured CABLES IN SIZE
1	Manufacturer's name and work address		
2	Standard specification to which the material shall		
3	VOLTAGE GRADE		
4	NO OF CORES		
5	CONDUCTOR DETAILS:		
	A	Normal cross section area of :	
		1 Phase Conductor (Sq.mm)	
		2 Neutral Conductor (Sq.mm)	
	B	No and size of strands (in mm) of	
		1 Phase Conductor (Sq.mm)	
		2 Neutral Conductor (Sq.mm)	
	C	SHAPE OF CONDUCTOR	
	D	Whether compacted or non compacted	
	E	Resistance at 27 °c	
		1 Phase Conductor ohm/km	
		2 Neutral Conductor ohm/km	
6	INSULATION		
	1	TYPE	
	2	Colour	
	3	Thickness	
	A	Phase Conductor (sq.mm)	
		1 Nominal (mm)	
		2 Minimum (mm)	
	B	Neutral Conductor (Sq.mm)	
		1 Nominal (mm)	
		2 Minimum (mm)	
7	Type of inner sheathing and colour		
8	Whether Binder Tape provided		
9	ARMoring		
	A	Type	
	B	Dimension (mm)	
10	Outer Sheath		
	A	Material	
	B	Thickness	
		1 Nominal (mm)	
		2 Minimum (mm)	
	C	Standard to which it Confirm	
11	A	Type and size of filler used	
	B	MIN. WT. OF FILLER IN KG./KM	
12	MAX. OVERALL DIAMETER OF THE CABLE IN MM		
13	Nature of Packing		
14	DRUM		
	A	TARE WEIGHT OF DRUM	
	B	WHETHER DRUM IS WHELL	
	C	STANDARD SPECIFICATION TO WHICH	
	D	DRUM DETAILS & DIMENSIONS	
	E	Whether 2-Full Ply Flange Construction or 2- Full Ply plus 1 Segmental layer Flange Construction.	

S.No	PARTICULARS		MULTIPLE CORE XLPE UNARMoured CABLES IN
	1	Drum size	
	A	Flange Diameter (d1) (mm)	
	B	Barrel Diameter (d2) (mm)	
	C	Centre hole Diameter (d3) (mm)	
	D	Overall with (L1) (mm)	
	E	Travers (L2) (mm)	
	G	Thickness of Flange	
	H	Barrel End (Supporting disc or	
	1	Diameter (mm)	
	2	Thickness (mm)	
	I	Stretchers (core carrier Planks)	
	1	Number (Min)	
	2	Thickness x width (mm)	
	J	Barrel Battens thickness	
	K	Barrel Middle supports	
	L	Thickness of External Lagging	

42.1. TECHNICAL SPECIFICATION FOR FOUR CORE AND TWO CORE PVC INSULATED & PVC INSULATED & PVC SHEATHED LT ARMoured CABLES

1. Scope:

1.1 This section provides for manufacture, testing before dispatch, supply and delivery F.O.R. destination of 4 Core & 2 Core PVC insulated and PVC sheathed armoured circular cables with aluminium conductor suitable for working voltage up to & including 1100 Volts ISI marked & conforming to IS 1554 (Pt-1) 1988 with latest amendments.

2. STANDARDS:

2.1	IS: 1554 (PT-1)/1988	PVC Insulated (heavy duty) electric cable for working voltages up to and including cables.
2.2	IS:8130/1984	Conductors for insulated cables
2.3	IS:5931/1984	PVC insulation and sheath of electric cables.
2.4	IS:10810/1984	Method of test for cables
2.5	IS: 3975/1979	Galvanized steel wire/strips
2.6	IS:10418/1982	Drums for electric cables

3. CLIMATIC CONDITION

The Equipment/material to be supplied against this specification shall be suitable for satisfactory operation under the following climatic Conditions.

SNo.	Location	At various locations in the state of Haryana
(i)	Maximum ambient temperature (°C)	60
(ii)	Maximum ambient air temperature (°C)	-5
(iii)	Maximum average daily ambient temperature (°C)	40
(iv)	Maximum yearly weighed average ambient temperature (°C)	32
(v)	Maximum altitude above mean sea level (m)	1000
(vi)	Minimum Relative Humidity (%)	26
(vii)	Maximum Relative Humidity (%)	95
(viii)	Average no of Rainy days/year	120
(ix)	Average annual rainfall	900 mm
(x)	Maximum wind pressure	195 kg/m sq

The equipment shall be for use in moderately hot and humid tropical climate, conducive to rust and fungus growth.

4. GENERAL REQUIREMENT

4.1 The ISI marked PVC insulated Armoured cables shall conform to IS:1554 (Pt-1)/1998 with latest amendment and bear BIS certification mark. The material used for construction of the cables shall be of best qualities complying with the requirement of IS:1154 (pt-1)/1988 and other relevant standards. The cables shall be suitable for outdoor/indoor installation free in air and shall be capable of withstanding the

normal stresses associated with transportation, erection, reeling and unreeling operations without getting deformed.

4.2 The cable shall be suitable for use where combination of ambient temperature and temperature rise due to load results in a conductor temperature not exceeding 70 degree C under normal operation and 160 degree C under short circuit condition.

4.3 The PVC insulated Armored LT Cable shall be ISI marked. The tenderer (MANUFACTURER) must furnish valid ISI certificate along with offer.

5. MATERIAL:

5.1 CONDUCTOR:

The conductor shall be composed of aluminium wire complying with IS:8130/1984 with latest amendments.

5.2 INSULATION:

Insulation shall be Type –A PVC composed of aluminium wire complying with IS:8130/1984 with latest amendments.

5.3 FILLERS:

5.3.1 The filler shall be of vulcanized rubber, un-vulcanized rubber or Thermoplastic material and shall be provided to fill the gaps between cores.

5.3.2 The filler material shall be so chosen so as to be compatible with temperature of the cable and shall have no deleterious effect on other components of the cable. These shall not be harder than PVC used for insulation and outer sheath respectively.

5.4 ARMOURING:

Armoring shall be of galvanized round steel wires for cable size 6 Sq. mm whereas armouring shall be of galvanized steel strips for cable sizes above 6 Sq. mm.

5.5 OUTER SHEATH:

The outer sheath shall consist of type ST-1 PVC Compound conforming to the requirements of IS: 5831/1984

6. CONSTRUCTION:

6.1 CONDUCTOR :

The construction of the conductor shall be stranded for cable size above 10Sq. mm whereas it is solid for 6 Sq. mm as per Clause No 8.1 of IS: 1554 (Pt-1) 1988 & relevant clause of IS:8130/1984.

6.2 INSULATION:

The conductor shall be provided with Type –A PVC compound insulation applied by extrusion. The insulation shall be so applied that it fits closely on the conductor and it shall be possible to remove it without damage to the conductor. The thickness and tolerance on thickness of insulation shall be as per clause No 9.2 of IS:1554(Pt-1)/1988.

6.3 CORE IDENTIFICATION:

The core shall be identified by different coloring of PVC insulation as per clause no. 10.1 of IS:1554(Pt-1)/1998.

6.4 LAYING UP OF CORES:

The core shall be laid up together with the suitable right hand lay. The interstices shall be filed with non-hygroscopic material.

6.5 INNER SHEATH (COMMON COVERING):

6.5.1 The laid up cores shall be provided with an inner sheath applied by extrusion. It shall be ensured that it is as circular as possible. The thickness of inner sheath shall be as given in Table-4 of IS: 1554(Pt-1)/1988.

6.6 ARMORING:

6.6.1 APPLICATION

Armouring shall be applied over the inner sheath. The armour wires/strips shall be applied as closely as possible.

The direction of lay of armour shall be left hand. A binder tape may be provided on the armour.

6.6.2 TYPE OF ARMORS DIMENSION:

The armour shall consist of galvanized round steel wires for cable size 4 Sq. mm & 6 Sq. mm whereas it shall be galvanized steel strips for cable size above 6 Sq. mm with the dimensions as specified in Table -6 of IS: 1554(Pt-1)/1988.

6.6.3 JOINTS:

The joints in the armour wire/strips shall be made by brazing or welding and the surface irregularities shall be removed. A joint in any wire/strips shall be at least 300 mm from the nearest joint in any other armour /wire in the completed cable.

6.7 OUTER SHEATH

6.7.1 The outer sheath consists of type ST-PVC compound & shall be applied by extrusion over the armouring.

6.7.2 The color of the outer sheath shall be black.

6.7.3 The minimum thickness of PVC outer sheath shall not fall below the thickness specified in Table-7 of IS: 1554 (Pt-1)/1988.

7 TESTS AND TEST CERTIFICATES:

7.1 The cable should meet the requirement of all tests including optional tests as specified at clause No 15.4 of IS: 7098 (Pt-I)/1988.

7.1.1 The following shall constitute routine tests:

7.1.1.1 Conductor resistance test

7.1.1.2 High Voltage test

7.1.2 The following shall constitute Acceptance tests:

7.1.2.1 Tensile test (for Aluminium)

7.1.2.2 Wrapping test (for Aluminium)

7.1.2.3 Conductor resistance test.

7.1.2.4 Test for thickness of Insulation & Sheath

7.1.2.5 Tensile strength & elongation at break of Insulation & sheath

7.1.2.6 Insulation resistance test.

7.1.2.7 High Voltage test at room temperature

7.1.2.8 Cold Bend Test

7.1.2.9 Cold Impact Test

7.1.2.10 Armor resistance Test

7.1.3 The following shall constitute type tests:

7.1.3.1 Tests of Conductor

7.1.3.1.1 Tensile test (for aluminium)

7.1.3.1.2 Wrapping test (for aluminium)

7.1.3.1.3 Conductor resistance test

7.1.3.2 Test for Armoring Wires/Strips

7.1.3.3 Test for thickness of insulation and sheath

7.1.4 Physical test for insulation:

7.1.4.1 Tensile strength and elongation at

- 7.1.4.2 Ageing in air oven.
- 7.1.4.3 Hot Deformation Test.
- 7.1.4.4 Shrinkage Test.
- 7.1.4.5 Loss of Mass in Air oven.
- 7.1.4.6 Heat Stock Test
- 7.1.4.7 Thermal Stability Test

- 7.1.5 Physical test for Outer Sheath
 - 7.1.5.1 Tensile Strength and elongation at break.
 - 7.1.5.2 Ageing in air oven
 - 7.1.5.3 Loss of mass in air oven
 - 7.1.5.4 Shrinkage Test
 - 7.1.5.5 Hot Deformation Test
 - 7.1.5.6 Heat Shock Test
 - 7.1.5.7 Thermal Stability

- 7.1.6 Insulation resistance test.

- 7.1.7 High Voltage test at room temperature

- 7.1.8 High voltage test at room temperature

- 7.1.9 Flammability test

7.2 The tendered must also clearly indicate various testing facilities available at their works for testing the material as per relevant standards. In case of otherwise, particulars of the place where such testing is proposed to be conducted during the course of inspection, shall be indicated with the offer.

8. INSPECTION:

8.1 The inspection may be earned out by the purchaser at any stage of manufacture. The successful tenderer shall grant free access to the purchaser's representatives at a reasonable time when the work is in progress. Inspection and acceptance of any equipment/material under this specification by the purchaser shall not relieve the supplier of his obligation of furnishing equipment in accordance with the specification and shall not prevent subsequent rejection if the equipment I material is found to be defective.

8.2 The supplier shall keep the purchaser informed in advance about the manufacturing program so that arrangement can be made for inspection.

8.3 The acceptance tests as per IS: 1554(Pt-I)/1988 shall also be conducted by the manufacturer before dispatch in the presence of our Representative I Inspecting Officer as per relevant clause of "General Conditions of Contract" along with verification of lengths & weight and checking the manufacturing defects, if any of samples coils. The mass of aluminium, XLPE, PVC & Filler in sample coils shall also be verified by the inspecting officer(s). Cold bench/cold impact test (IS: 5831/1984) shall constitute the optional tests and shall be conducted on each offered lot of the cables of each size as per Clause No. 15.4 of IS; 1554 (Pt-I)/1988.

8.4 At least 5% of total numbers of drums subject to minimum of 2 in each lot put up for inspection shall be selected at random to ascertain the length/workmanship of cable by the following method:

At the work of the manufacture, the cable shall be transferred from one drum to another for checking any manufacturing defects in the cable drum selected for conducting acceptance tests, at the same time measuring its length with the help of the graduated pulley & cyclometer. The difference in the average length thus obtained from the declared length by the supplier in the packing list shall be applied to all the drums if the cable is found short during checking the sample lot(s).

8.5 TEST CHARGES:

All test charges incurred towards test checking of the material received in our stores shall be borne by the Nigam.

9. Identification:

9.1 The Manufacture shall be identified through-out the length of cables as per clause No. 17.1 of IS: 1554(Pt-1)/1988.

9.2 In order to distinguish these electric cables from telephone cables, the word ELECTRIC shall be indicated, pointed or embossed throughout the length of the cable on outer sheath.

9.3 The cable code shall be provided as per Clause No 17.3 of IS:1554 (Pt-I)/1988.

9.4 The cable shall also be required to be embossed with the word name of manufacture or trade name, cable code, voltage grade, DHBVN, size of cable, year of manufacture and ISI certification mark at every meter length for which no extra charges shall be paid.

10. Packing and Marking:

10.1 The cables shall be wound on non-returnable wooden drums conforming IS:10418/1982 of suitable size and packed. The ends of the cable shall be sealed by means of non-hygroscopic sealing material. Only one cable length shall be supplied on a drum.

10.2 The cable shall carry the following information stencilled & painted on the drum:

10.2.1 Manufacturer's name, Brand name or trade mark.

10.2.2 Type of cable and voltage grade.

10.2.3 Number of cores.

10.2.4 Nominal Cross-sectional area of the Conductor.

10.2.5 Cable code.

10.2.6 Length of cable on the drum.

10.2.7 Approximate gross weight.

10.2.8 Year of manufacture.

10.2.9 BIS Certification marks.

10.2.10 Name of the consignee and full destination.

10.2.11 Tender number / Purchase order No.

10.2.12 The word SUITABLE FOR OUTDOOR USE & LOW TEMPERATURE CONDITIONS.

11. Standard Length:

11.1 The cables shall be supplied in the standard length of 500 Meters for size 4C X95 Sq. mm, 4Cx50 Sq.mm, 4Cx25 Sq.mm, 4Cx 16 Sq. mm and 1000 meters for size 4C X 10 Sq. mm, 2CX15 Sq. mm, 2C X10 Sq. mm, 2C X6 Sq mm

11.2 A tolerance (+/-) 5% shall be allowed in standard length.

11.3 Only one cable length shall be acceptable by non-standard length measuring not less than 50% of standard length to complete the ordered quantity in each size.

12 Quantity:

The quantities as mentioned in the Schedule of requirement are tentative & these may increase/decrease as per the requirement of the Nigam.

13 Quantity Tolerance:

The quantity tolerance of (+/-) 2% shall be allowed in each size for completion of supply.

14 Guaranteed Technical Particulars

The tenderer shall furnish guaranteed technical particulars in the relevant schedule.

15. Constructional Drawings:-

The tenderer is required to furnish the detailed construction drawing of the cable clearly showing shape of core, type and size of fillers & interstices along with centre filler etc. In absence of this the tender is likely to be ignored.

Guaranteed Technical and Other Particulars

Sr. No	Particulars		PVC Armorer cables in Sq.mm			
			Size-1	Size-2	Size-3	...
1.	Manufacturer's name and works address					
2.	Standard specification to which the material shall					
3.	Voltage Grade					
4.	No of Cores					
5.	Conductor Details					
	Normal Cross section area of :					
A	1	Phase Conductor (Sq. mm)				
	2	Neutral Conductor (Sq.mm)				
		No. and size of strands (in mm)				
B	1	Phase Conductor (Sq.mm)				
	2	Neutral Conductor (Sq.mm)				
C	Shape of Conductor					
D	Whether compacted or non compacted					
	Resistance					
E	1	Phase Conductor (Sq.mm)				
	2	Neutral Conductor (Sq.mm)				
6	INSULATION					
	1	Type				
	2	Color				
	3	Thickness				
A	Phase Conductor (Sq.mm)					
	1	Nominal (mm)				
	2	Minimum(mm)				
7.	Type of inner sheathing and colour					
8.	Whether Binder Tape Provided					
9.	Armoring					
	A	Type				
	B	Dimension (mm)				
10.	Outer Sheath					
	A	Material				
	B	Thickness				
	1	Nominal (mm)				
	2	Minimum (mm)				
	C	Standard to which it Confirm				
11	A	Type and size of filler used				
	B	Min. WT of filler in KG/KM				
12	Max. Overall diameter of the cable in MM.					
13.	Nature of Packing					
14.	Drum					
	A	Tare Weight of Drum				
	B	Whether Drum is wheel mounted				
	C	Standard specification to which drum shall conform.				
	D	Drum details & dimensions				
	E	Whether 2-Full Ply Flange Construction or 2-Full				
	1	Drum Size				
	A	Flange Diameter (d1) (mm)				
	B	Barrel Diameter (d2) (mm)				
	C	Centre Hole Diameter (d3) (mm)				
	D	Overall with (L-1) mm				

Sr. No	Particulars		PVC Armorer cables in Sq.mm		
			Size-1	Size-2	Size-3 ... so on
	E	Travers (L2) (mm)			
	F	Thickness of Flange			
	G	Barrel End supporting disc or core			
		1 Diameter (mm)			
		2 Thickness (mm)			
	H	Stretchers (Core carrier Planks)			
	1	Number (min.)			
	2	Thickness x width (mm)			
	I	Barrel Battens Thickness (Core filler)			
	J	Barrel Middle Supports (Middle core discs)			
	K	Thickness of External Lagging (mm)			
2		Details of Metal Components			
A		Clamping Studs with Hexagonal Nuts			
	1	Numbers			
	2	Diameter (mm)			
B		Square of Round Washers			
	1	Numbers			
	2	Diameter (mm)			
C		M.S. Bushes			
	1	Numbers			
	2	Thickness of Sleeve (mm)			
	3	Dimension of Sleeve (mm)			
	4	Number of Bolts			
	5	Diameters of Bolts			
D		M.S/C.I Centre Plate			
	1	Numbers			
	2	Diameter of Bolts (mm)			
	3	Centre Plate Bolts (mm)			
	A	Numbers			
	B	Diameter of Bolts (mm)			
E		Centre Hole Diameter (mm)			

43.1. TECHNICAL SPECIFICATION FOR OUTDOOR LT FEEDER PANEL WITH SWITCHGEAR

1.0 SCOPE

This specification covers the technical requirements of design, manufacture, testing at manufacturer's works, packing; forwarding, supply and unloading at store/ site of feeder pillar panel with ACBJMCCBs of the ratings as mentioned in the specification below. The ACB/MCCBs shall be completing with all accessories for efficient and trouble free operation and all the equipments shall be in one enclosure.

2.0 APPLICABLE STANDARDS

The equipment covered by this specification shall conform to the requirements stated in latest edition of relevant applicable ISI/IEC and other applicable standards and shall conform to the regulations of local statutory authorities.

IS 13947-1-1993 /IEC 60947-1-1988	: Specification for LV Switchgear &Control gear - General Rules
IS 1 3947-2-1 993 / IEC 60947-2-1989	: Specification for LV Switchgear &Control gear - Circuit Breakers
IS 12063/ IEC 60529 -1989	Degree of Protection provided by Enclosures
IS 5039/ IEC 61439-1 & 2	Specification for distribution Pillars below 1000v AC
IS 8623 (Pt.2)-1993 IEC 61439-1& 6 – 2009	Specification L.V. switchgear & control gear assemblies — Particular requirements for bus bar trucking systems (bus ways)
IS 2551 — 1982	Danger Notice Plates
IEC 60664	Insulation co-ordination within Low voltage systems including clearances & creepage distances for equipment
IEC 61140	Installations through door of Class-II Switchboards / Enclosures
IEC 61557-12	Metering
IS 14772-2000	General requirement for enclosures for accessories for household and similar fixed electrical installation.
IS 5	Color if ready mixed paints
IS 191	Specification for Copper
IS 5082	Wrought Aluminium & Al alloy plates & sheets for electrical applications
IS 4759	Hot-dip Zinc coating on structural steel and other allied products.

3. SERVICE AND CLIMATIC CONDITIONS OF THE INSTALLATION Service Conditions

SR. No.	TITLE	STANDARD
3.1	Supply Voltage	3 Phase neutral, AC 433 Volt +/- 10%
3.2	Supply Frequency	50 HZ 14- 5%
3.3	Location of panel	Outdoor, on footpath or Roadside
3.4	Pollution	Heavily Polluted and Dry
3.8	Incoming Supply to feeder panel	From Distribution transformer or Main feeder pillar panel

Climatic Conditions

S.N.	Parameter	Unit	Value
1	Location		DHBVN, Haryana
2	Max. Ambient Air Temp	deg. C	50
3	Min. Ambient Air Temp	deg. C	-5
4	Max. Average Daily ambient Temp	deg. C	40
5	Max. yearly weighted Average ambient Temp	deg. C	32
	Max. Relative Humidity	%	100
7	Min. Relative Humidity	%	26
8	Average Annual Rainfall	mm	900
9	BASIC WIND SPEED	m/s	47
10	Maximum Altitude above mean sea level	meter	1000
11	Isoceraunic level	days/yr	45
12	Average No. of Rainy Days Per annum	no.	120
13	Pollution		Moderate
14	Seismic Zone		Zone-IV,III,II

The atmosphere is generally laden with mild acid and dust in suspension during the dry months and is subjected to fog in cold months, The design of equipment and accessories shall be suitable to withstand seismic forces corresponding to an acceleration of 0.1 g.

a. FEEDER PILLAR CONFIGURATION

Sr. No.	Feeder Pillar Type	Incoming Feeder (Circuit Ways/ Cable Size)	Outgoing Feeder (Circuit Ways/ Cable Size)
4.1	Type - A, 6 WAY (DT Panel)	1X1600A ACB/ SIC 630 sq. mm. X 3 lead per Phase	5X400A MCCB / 3.5CX300 Sq. mm
4.2	Type - B, 5 WAY (DT Panel)	1X1250A ACB / SIC 630 sq. mm. X 2 lead per Phase	4X400A MCCB / 3.5CX300 Sq. mm.
4.3	Type —C, 4 WAY (DT Panel)	1X800A ACB /S/C 630 sq. mm.	3X400A MCCB/ 3.5CX300 Sq. mm.
.2	Type - D, 7 WAY (Feeder Panel)	2X400A MCCB/ 3.5CX300 Sq. mm.	5X100A MCCB/ 3.50120 Sq. mm
4.3	Type - E, 12 WAY (service Pillar)	100A Bus Bar only (2 incoming) / 3.5CX120 Sq. mm.	100A Bus bar only (10 outgoing) / 3.5CX50 Sq. mm.

5.0 GENERAL TECHNICAL REQUIREMENTS:

Sr. No.	DESCRIPTION	REQUIREMENT
5.1	Installation	Outdoor
5.2	Rated Voltage	415 V
5.3	Rated Frequency	50 Hz
5.4	Wiring System	3 Ph 4 Wire
5.5	System earthing	Solid
5.6	Impulse Withstand Voltage	12KVp for ACB and 8kVp for MCCB
5.7	Rated short time fault current	50 KA/35kA for 1 Sec as per the ACB/MCCB rating as defined below
5.8	Bus Bar material	Aluminium
5.9	Bus Bar configuration	2 no. Incoming 6 nos. Outgoing for Type A to C pillars and 2 no. Incoming 10 nos. Outgoing for Type E pillar.
5.10	Bus bar arrangement	Horizontal with R Phase bus at top
5.11	Maximum Current density of Aluminium bus bar	0.8 A/Sq. MM
5.12	Ingress protection class for enclose	IP 54 for Outdoor application. (LT panel shall be as per indoor type).
5.13	Temperature rise	Temp rise above ambient as per relavant IEC
5.14	Type of I/C and O/G protection	ACB for incoming for type A to C and MCCB for type D. MCCB for outgoing for type A to D.

Sr. No.	DESCRIPTION	REQUIREMENT
5.15	Cable entry	From bottom only
5.16	Lifting lug	2 nos. lugs on top. preferably welded type.
517	Metering chamber	Provision shall be made to mount the DLMS meter as per Nigam's specs

6.0 PANEL CONSTRUCTION

All the ACB/MCCB along with bus bar as mentioned in clause-4 above shall be in one enclosure (feeder pillar). The feeder panel construction shall confirm to following features;

Sr. No.	DESCRIPTION	REQUIREMENT
6.1	Installation	Outdoor
6.2	Panel Construction	Free standing floor mounted with steel frame. The enclosure shall be rugged, corrosion resistant.
6.3	Welded Construction	Continuous welding from inside, spot welding not acceptable.
6.4	Ingress protection class for enclosure	IP 54 as per IS 12063
6.5	Material	Hot dip Galvanized sheet CRCA. The ground parts shall have heavy duty corrosion protection.
6.6	Sheet steel Thickness	3mm — support frames 2mm Galvanized — Covers, Doors & Canopy
6.7	Base Frame	3mm MS Channel of minimum height 300mm with side covers of galvanized MS painted in black.
6.8	Bottom holes	Oval shape
6.9	Cable Entry and Cable Supports	From Bottom side/ Non ferrous clamps at bottom
6.10	Lifting Lug	2 nos. lug welded on top_2
6.11	Canopy on Top	With minimum 10 Deg. C. slope, extended 100mm. outside from panel on front and rear.
6.12	Door Type for access	For outdoor application, Front access Central opening double leaf with insulating rubber grip handle, No door at rear side. Panel to be access only from front. , Right hand side leaf can be opened only after left hand side leaf. The door of the LT panel shall be single leaf type, with supporting hinges and shall operate with swing peration. However door of the LT compartment shall be with double openable doors. However, performance parameter and rating of equipments shall be as per RFP.
6.13	Double leaf doors	For outdoor application, Right hand side leaf can be opened only after left hand side leaf. The door of the LT panel shall be single leaf type, with supporting hinges and shall operate with swing peration. However door of the LT compartment shall be with double openable doors. However, performance parameter and rating of equipments shall be as per RFP.
6.14	Door Hinges	Minimum three anti theft type hinges. Hinges shall not be visible from outside and hence not removable_ Tight fit brass tube-100mm ID, 12_7mm OD & 20mm length. All accessories such as hinges. screws shall be of non-corroding material.
6.15	Door Opening	Minimum 150 Deg.

Sr. No.	DESCRIPTION	REQUIREMENT																		
		Direct screens printed SL.D shall be provided on the internal side of the doors. The door shall be fitted with gaskets made of non- inflammable and self-extinguishing EPDM rubber. The gaskets used for the pillar shall be self-pressurized type.																		
6.16	Locking facility on door	The door(S) shall have three point locking arrangement. Special type tampered heavy duty built-in inter-locks shall be provided. Two nos. master keys for locking device shall be supplied for each feeder pillar. All the feeder pillar boxes locks shall be operational by the master key. Locking system with handle and up & down arrangement shall be provided on the front. Operating handle shall be swing type made with insulating material. The door shall be provided with pad-locking facility also. The arrangement of the locking device shall be such that self-locking of doors is avoided and door shall be locked/unlocked by appropriate key only.																		
6.17	Tower bolts at top and bottom of door	On left hand side door																		
6.18	Base Gland plate	The Pillar shall be provided with removable split type base plate to facilitate cable jointing. The base plate shall be split along the corner line. It shall be possible to temporarily detach the front side half portion of the base plate for purpose of installing outgoing cables at site. The cable should enter through twin leaf cable clamps mounted on the earthing channel. The Cable gland plate shall be of 3mm thickness and shall be provided with knockout punches for I/C and O/G cables. Gland plates shall have appropriate rubber bellows to prevent the ingress. Proper support shall be provided for holding the I/C and O/G cable. Thus. cable support arrangement shall be provided to take the load of the cable. Vendor has to coordinate with contractor for Cable termination arrangement.																		
6.19	Apron	Feeder Pillar shall be provided with an Apron on all the four sides. The Apron shall be made from hot dip galvanized steel sheet (Grade Z 275) of longer life with thickness 3 mm. The angle shall be made with hot dip galvanized steel sheet (Grade Z 275) of longer life of the frame. Aprons shall be provided below the door level of the pillar up to a depth of 300 mm and shall be easily removable. The Pillar shall be provided with a stand of iron angle 75*75*6n-im at each corner. A welded plate shall be provided at bottom of each leg of pillar stand for support.																		
		As per IS, Electrolytic grade Aluminium of uniform sections to carry the continuous rated current without excessive heating.																		
6.21	Bus bar color coding for R, Y B,& Neutral and arrangement	Heat shrinkable tape of color Red, Yellow, Blue & Black respectively. Arrangement shall be Horizontal with R phase bus at top. For Type E pillar box, provision of holes for connections for incoming and outgoing cables shall be made.																		
6.22	Bus Bar Size (As per type mentioned in clause-4 above)	<table border="1"> <thead> <tr> <th data-bbox="592 1570 826 1615">Type</th> <th data-bbox="826 1570 1050 1615">Phase</th> <th data-bbox="1050 1570 1246 1615">Neutral</th> </tr> </thead> <tbody> <tr> <td data-bbox="592 1615 826 1715">Type -A</td> <td data-bbox="826 1615 1050 1715">100X10MM (2 Run)</td> <td data-bbox="1050 1615 1246 1715">100X10MM (2 Run)</td> </tr> <tr> <td data-bbox="592 1715 826 1794">Type —B</td> <td data-bbox="826 1715 1050 1794">150X6MM (2 Run)</td> <td data-bbox="1050 1715 1246 1794">150X6MM. (2 Run)</td> </tr> <tr> <td data-bbox="592 1794 826 1861">Type —C</td> <td data-bbox="826 1794 1050 1861">100x10mm (1 Run)</td> <td data-bbox="1050 1794 1246 1861">100x10mm (1 Run)</td> </tr> <tr> <td data-bbox="592 1861 826 1928">Type —D</td> <td data-bbox="826 1861 1050 1928">100X6 MM (1 Run)</td> <td data-bbox="1050 1861 1246 1928">100X6 MM (1 Run)</td> </tr> <tr> <td data-bbox="592 1928 826 1995">Type -E</td> <td data-bbox="826 1928 1050 1995">50X6 MM (1 Run)</td> <td data-bbox="1050 1928 1246 1995">50X6 MM (1 Run)</td> </tr> </tbody> </table>	Type	Phase	Neutral	Type -A	100X10MM (2 Run)	100X10MM (2 Run)	Type —B	150X6MM (2 Run)	150X6MM. (2 Run)	Type —C	100x10mm (1 Run)	100x10mm (1 Run)	Type —D	100X6 MM (1 Run)	100X6 MM (1 Run)	Type -E	50X6 MM (1 Run)	50X6 MM (1 Run)
Type	Phase	Neutral																		
Type -A	100X10MM (2 Run)	100X10MM (2 Run)																		
Type —B	150X6MM (2 Run)	150X6MM. (2 Run)																		
Type —C	100x10mm (1 Run)	100x10mm (1 Run)																		
Type —D	100X6 MM (1 Run)	100X6 MM (1 Run)																		
Type -E	50X6 MM (1 Run)	50X6 MM (1 Run)																		

Sr. No.	DESCRIPTION	REQUIREMENT
		Note: - Bus bar size as defined above can vary as per manufacturer design, however it should be in accordance with the current rating defined in the clause-4 above.
6.23	Earth Bus at panel bottom	25X6mm Aluminium 25.4 mm
6.24	Min. Clearance between phases to phase bus	25.4 mm
6.25	Min. Clearance between Phase Bus Bar to earth bar	19.4 mm
6.26	Minimum Current Density of busbar	0.8 A/mm ² - should be compliant to Rated Breaking Capacity of ACB/MCCB.
6.27	Max. Permissible temp. rise	Temp rise above ambient as per relevant IEC.
6.28	Bus Bar Support insulators/ phase barriers	Bus bars shall be insulated with suitable heavy duty synthetic rubber insulation. Type test certificates (ERDA/CPRI) to be provided for this insulation material. A minimum 4 Nos. of Bus bars insulators shall be used in the pillar so that the bus bars shall be rigidly mounted and the operation of fuse switches will not cause any overstressing of bus bars and / or feeder to bus bar joints. All bolted electrical joints shall be secured by corrosion proof stainless steel bolts. Shrouding shall, as far as possible, be provided such as to form an insulated barrier (FRP/Acrylic insulating sheet) between the operator and the live parts. Non hygroscopic, noncombustible type Bus bar insulators of material such as SMC/DMC (non Bakelite material) shall be used. It shall be as per manufacturer's type test design.
6.29	Feeder Circuits	For outdoor application, I/Cs shall be at extreme ends of the bus bar. Each Circuit way shall be provided with ACB/MCCB of the required rating except Type-E feeder panel. Main incomer ACB shall be placed in the centre of the panel as per manufacturer design and standard. However, performance parameter of LT panel shall be as per DHBVN specification for LT feeder pillar of similar ratings.
6.30	Cable Termination	All cables shall be terminated from front In a horizontal plane at one level. Cable termination arrangement shall be from bottom and suitable for external cables of type and sizes as mentioned in the specification. Aluminium cable lugs of Long Barrel type and washers shall be provided for cable termination as per relevant IS. Removable split type base plate with cable holes to suit the cable sizes and bellow type gasket of non-inflammable and insulating vermin proof material shall be provided. The base plate shall be split along the center line with knockout punches suitable for the cables. It shall be possible to temporarily detach the front side half portion of the base plate for purpose of installing outgoing cables at site. Aluminium links with hole to suit the cable size shall be provided for termination of I/C& O/G cables. Each I/C and O/G cable shall be provided with

Sr. No.	Description	Requirement
6.30	Cable Termination	suitable GC clamp having its own independent set of fixing nuts and bolts and shall be mounted on a separate, continuous, rigid support strip such that it can bear the load of the cables as specified in the specification, and the same shall be properly earthed with bolted lugs at both ends. The cable clamp shall be of twin leaf type so that cable will be supported by the inner clamp and armor wires will be tightened between inner and outer clamps. Width and thickness of the clamps shall not be less than 50mm & 5mm respectively and clamp size shall be as per cable sizes given in the GTP. Cable termination clearance from gland plate shall be 300mm minimum. Cable connection shall be done from the front side & two incomer circuits shall be labeled. There shall be suitable arrangement for earthing of armoring of cable
6.31	Earthing	<p>The FP shall be provided with an Aluminium Earth bus at the bottom, suitable for the Rated short time current of the pillar. The earth bus shall provide earthing to all the components</p> <p>Inside the pillar and the metallic enclosure including the armor of the cables. The earth bus shall be internally connected to two separate earth terminals located outside, on either side of the pillar. The earth bus shall be located at sufficient height from the gland plate. The bus bar shall not be visible or removable from the outside of the cubicle. Door earthing shall also be provided with bolted lugs at both ends. The neutral shall be insulated from the earth. The earth terminals / studs shall be of a suitable size to accommodate the earth conductor and corrosion protected to provide connection to the external earth conductors on each side of the pillar. The earth terminals shall be identified by means of the sign I marked in a legible and indelible manner on or adjacent the terminals, The earthing studs shall be welded from inside the pillar cubicle and shall be covered from the top so as to prevent access for theft. The earthing terminals shall be so placed that the earth connection of the FP is maintained when the cover or any other movable part is removed.</p>
6.32	Pillar Lighting	Lighting shall be as per manufacturer's standard. LED lamps shall be used for illumination.
6.33	Painting	The Powder coating shall be applied on clean, dry surface under suitable atmospheric conditions The shade of the paint shall be PENTON E2727C with thickness not less than 80 microns. Two nos. Retro reflective paint strips, each of 75mm height shall be provided on all the four faces of the FP. The Retro reflective paint of grey black colour and white reflectance shall withstand the temperature conditions of the FP installed. The paint shall have good colour retention properties and shall be weather and UV resistant. The Retro reflective paint should reflect vehicular light at night time providing safety to traffic.

6.34	Protective Measures	<p>The design of the FP shall ensure that there is no possibility of the operator experiencing a shock during normal operation. Insulated barriers shall be provided wherever necessary so as to ensure that no accidental contact with any live parts inside the FP is possible. Under all circumstances, the fuse blade shall pass through insulated shrouds before contact is made. Heavy duty wrap around insulated contact shrouds shall not come out even after years of service. Where bus bars and live connections are contained in the same compartment as terminals for outgoing, the bus bars and live connections shall be shrouded so as to prevent accidental contact with live metal parts during cabling operations with the live equipment.</p> <p>Each FP shall be provided with a Danger Plate of Aluminium sheet embossed / engraved with 415V AC and danger mark in English and Hindi as per IS 2551-1982, on the front as well as back door, towards left hand side and upper end corner. The bidder shall provide suitable arrangement for fixing the aluminium plate onto the door so that the plate is not removable.</p>
6.35	Panel Maximum dimensions in MM	<p>All the ACB/MCCB along with bulbar as mentioned in clause-4 above shall be in one enclosure (feeder pillar). The drawing of feeder pillar panel construction and arrangement of equipments in thereof shall be submitted by the bidder and same shall be approved by engineer in charge of the project. The complete panel shall be type tested in accordance with IEC 61439-1 & 2</p>

44.1 SWITCHGEAR

All the switchgear (ACB/MCCB) used for LT distribution feeder pillar box shall be of reputed make like Havells, L&T, ABB, Siemens, Schneider, C&S and Alstom and shall be as per latest IS/IEC. The details are as under

44.2 LT Air Circuit Breakers:

44.2.1. General

The circuit breakers shall be of molded case design and the air break type, robust and compact design suitable for indoor mounting (mounted in outdoor type Distribution Box) and shall comply with the requirement IEC 60947-1 and 2. Rupturing capacity shall be as stipulated in Schedule of quantities, Heat loss per pole shall be low.

The breaker shall comply with the isolation function requirement of IEC 60 947-2 section 7.12 to be marked as suitable for isolation / disconnection to facilitate safety of operating personal while the breaker is in use.

The breaker shall provide class II insulation between the front panel and internal power circuits to avoid any accidental contact with the live main current carrying path with the front cover open.

Protective devices, metering, CTs, PTs, push buttons and indicating lamps shall be provided as per schedule of quantities.

44.2.2 Constructional Features

The Circuit Breaker shall be flush front, four poles as required. Each Circuit Breaker shall be housed in a separate compartment enclosed on all sides.

All current carrying parts in the breaker shall be silver plated and suitable arcing contacts shall be provided to protect the main contacts which shall be separate from the main contacts and easily replaceable. In addition, Arc chutes shall be provided for each pole, and these shall be suitable for being lifted out for the inspection of the main and the arcing contacts.

The circuit breaker shall have indication of mechanical wear of contacts enabling visible indication of contact life.

Sliding connections including those for the auxiliary contacts and control wiring shall also be of the self aligning type. The fixed portion of the sliding connections shall have easy access for maintenance purposes.

There shall be flexibility in changing the types of terminals at site to suit the bus bar orientation if required. ACB should have both side terminal adapter & trip indication contacts.

Individual fault trip LED indications shall be available on all types of trip units for easy & faster identifying the cause of fault.

ACB comprises of a LCD/LED display with phase currents and voltages

(running, average & max) parameters, along with built-in thermal memory,

Busbar— ACB terminal joint temperature sensing feature should be on modbus as per the communication architecture defined in clause 8.1 below.

The frame of the circuit breaker shall be uniform upto highest current rating of circuit breaker, this will help to minimize inventory.

The cubicle for housing the Breaker shall be free standing dead front pattern, fabricated from the best quality sheet steel.

ACB should have flexibility in terminal orientation by 90 degree.

Sr. NO.	DESCRIPTION	REQUIREMENT
1	Type of ACB	Fixed type Manually Operated (mounted in outdoor type Distribution Box)
2	Type of Releases	Self powered micro processor based trip unit
3	Rating (A)	1600/1250/800
4	Over Load Release setting	0.4-1 In
5	No. of Poles	Four
6	Rated Operational Voltage	690V AC
7	Rated ultimate short circuit breaking capacity (Icu)	50 KA
8	Rated service short circuit breaking capacity (Ics)	50 KA
9	Rated withstand short circuit breaking capacity	100% of Icu and 100% of Icw Ics=Icu=Icw=100% for 1 sec
10	Utilization Category	B
11	Rated Insulation Voltage	1000V AC
12	Rated Impulse withstand voltage	12 kVP
13	Overloading current with time setting	40 to 100 % Time setting (tr) from — 1s,2s,4s to ... 24 sec
14	Short Circuit Release setting with time setting	3 - 9 times of Ir setting STD Time — 50 ms to 400 ms
15	Instantaneous setting	400% to 1500% with function disable (off) option
16	Earth Fault Setting with time	30% to 70% Time Setting — 100ms to 400ms

44.2.3 Operating Mechanism

The Circuit Breaker shall be trip free with independent manual spring operated or motor wound spring operated mechanism as specified and with mechanical ON/OFF indication. The operating mechanism shall be such that the circuit breaker is at all times free to open immediately the trip coil is energized. The breaker shall be provided with in built anti pumping mechanism.

The closing time shall be less than or equal to 75 ms to ensure faster closing of the breaker. And tripping time should be less than 30 ms to reduce the let through energy in the event of fault.

The operating handle and mechanical trip push button shall be at the front of and integral with the Circuit Breaker.

There shall be mechanical indicator on the front panel for 'Ready to close' situation for the breaker by checking all inter lockings.

Mechanical and electrical anti pumping devices shall be incorporated in the ACB's as required.

44.2.4 Circuit Breaker Auxiliary Contacts

The Circuit Breaker shall have suitable free / minimum 4 NO/NC auxiliary contacts rated at 10 amps 415 volts 50 Hz. These contacts shall be approachable from the front for connecting all external wiring from the front.

Electrical Auxiliaries

All electrical auxiliaries, including the spring charging gear motor shall be instalable on site without requiring adjustment or any tools other than a screw driver

The auxiliaries shall be placed in a compartment which under normal operating conditions, shall not contain any conducting parts capable of entering into electrical contact with the circuit breaker poles. It shall be possible to connect all auxiliary wiring from the front of the circuit breaker.

44.2.5. Circuit breaker Releases

The Air Circuit Breakers should have microprocessor release.

The Incoming circuit breaker to be equipped with the microprocessor based release with adjustable short circuit protection with adjustable time delay, Over current protection, and adjustable earth fault protection with adjustable time delay. The release should have LCD/LED display phase currents and voltages (running, average & max) parameters the bar graphs to show percentage loading of the breaker to be available. It should be possible to store tripping history of last 10 faults with type of fault & values. ACB should be compatible to have ON/OFF & trip indication monitoring on mod bus over Ethernet at SCADA

The outgoing ACBs should have microprocessor based Release with Short circuit and overload protections with LCD/LED Display of current and Voltage. The bar graph on ACB to show percentage loading of the breaker to be available. On line setting of the parameters should be possible.

The setting of the ACB should be possible digitally (also Navigation Keys) or with dial type potentiometer setting with the help of screwdriver.

44.2.6. Earthing

The frame of the Circuit Breaker shall be positively earthed with earthing provision.

44.3. MOULDED CASE CIRCUIT BREAKERS:

44.3.1. General

The circuit breakers shall comply with the requirement of IEC 60947 / IS 13947: 1993. MCCBs shall be suitable for nominal voltage of 3 phases 415 Volts AC 50 HZ supply.

The circuit breaker shall comply with the isolation function requirement of IEC 60 947-2 section 7.1.2 to be marked as suitable for isolation / disconnection to facilitate safety of operating personnel while the breaker is in use.

The circuit breaker shall provide class II insulation between the front cover and internal power circuits to avoid any accidental contact with the live main current carrying path with the front cover open.

44.3.2. Constructional features

The MCCBs shall be made of halogen free high strength heat resisting and flame retardant thermo setting insulating material.

Three phase MCCBs shall have a common handle for simultaneous operation and tripping of all the three phases.

The contact tips shall be made of suitable arc resistant sintered alloy. Terminals shall be of liberal design with adequate clearances

Suitable arc extinguishing devices shall be provided for each contact.

Sr. No.	DESCRIPTION	REQUIREMENT	
1	Type of MCCB	Fixed type Manually Operated (mounted in outdoor type Distribution Box)	
2	Type of Releases	Thermal magnetic type with auxiliary contacts for communication to FRTU	
3	Rating (A)	100, 160 , 250	400 & 630
4	Over Load Release setting	0.8-1 In	0.8-1 In
5	No. of Poles	Four	Four
6	Rated Operational Voltage	415V	415V
7	Rated ultimate short circuit breaking capacity (Icu)	35kA rms	50kA rms
8	Rated service short circuit breaking capacity	100% of Icu	100% of Icu
9	Opening time on short circuit	Less than 10 - 15 ms	
10	Utilization Category	A	
11	Rated Insulation Voltage	690V	
12	Rated Impulse withstand voltage	8 kVP	
13	Thermal Release	Thermal Protection adjustable up to 630A	
14	Earth Fault Setting	10% to 50% in steps of 10% with adjustable time setting.	

44.3.3. Operating Mechanism

The operating handle of the MCCBs shall be quick make 1 break, trip free type.

The operating handle of the MCCBs shall have suitable, ON, OFF and TRIPPED indicators.

The operating handle and mechanical trip push button shall be at the front of and integral with the circuit breaker

MCCBs shall be capable of limiting the fault currents. The maximum thermal I^2t shall be indicated by the manufacturer.

MCCBs shall comprise of the mechanism designed to trip the circuit breaker in the event of high value short circuit currents.

The electrical endurance of MCCBs shall be more or equal to that specified by IEC 60 947-2 standard

Earth fault protection if specified should be provided by add on module with time delay and earth fault setting, there should be fault differentiation of over current and earth fault on MCCB or panel door.

MCCBs should be of the same family.

MCCB should be of cross bolted termination for cable connections to withstand higher thermodynamic stress.

44.3.4. Circuit Breaker Interlocking

MCCBs shall be provided with following interlocking devices.

Handle interlock to prevent unnecessary manipulations of the breaker.

Door interlock to prevent door being opened when the breaker is in ON position

Door defeat device to open the door even if the breaker is in ON position.

44.3.5. Circuit breaker auxiliaries

The circuit breaker shall be provided with following accessories, if specified in drawings/schedule of quantities

- a. Under voltage trip
- b. Shunt trip
- c. Alarm switch
- d. Auxiliary switch

44.3.5. Type test certificate

The contractor shall submit type test certificate from a international recognized test house f NABL accredited LAB for the circuit breakers offered,

44.4. MINIATURE CIRCUIT BREAKERS

The MCB's shall be of the completely moulded design suitable for operation at 240/415 Volts 50 Hz system.

The MCB's shall have a rupturing capacity of 10 KA at 0.5 pf.

The MCB's shall have inverse time delayed thermal overload and instantaneous magnetic short circuit protection..

44.5. Manufacturing Facilities

Sheet steel manufacturing shall be done according to the drawings on in house CNC cutting and bending machines.

In house facility to be available for seven tank pre treatment process and powder coating facilities The Pretreatment and painting process shall be regularly checked for the stability of the process the final paint thickness should be 60 to 80microns.

The manufacturer must have established stores with proper procedures for checking incoming material, stocking, rejection etc so that non-Quality material does not enter the shop.

In house facility for routine testing of the switchboards

The complete facility should have ISO 9001 certification.

44.6. NAME PLATE & MARKING

All the components and operating devices of the LT feeder panel Distribution Box shall be provided with durable and legible nameplates OR Screen printed, containing all technical parameters. Name plate & markings shall be in accordance with IS-13947-2 f IEC-60947-2 along with the following information:

- (a.) Manufacturer's Name
- (b.) Purchaser name and PO number
- (c.) Property of DHBVN

- (d.) Manufacturing Month & Year
- (e.) Type designation & serial no.
- (f.) Reference No. of the relevant standard
- (g.) Utilization category
- (h.) Rated Operational Voltage
- (i.) Rated current
- (j.) Rated frequency
- (k.) Rated service short Circuit breaking capacity (Ics)
- (l.) Rated ultimate short circuit breaking capacity (Icu)
- (m.) Line and load terminals
- (n.) Neutral pole terminals in ACB/ MCCB DB
- (o.) Protective earth terminal markings on ACB/MCCB DB
- (p.) Indication of Open and Closed positions on ACB/MCCB
- (q.) Terminal Marking
- (r.) A danger plate (1.6mm thick Aluminium) of appropriate size shall be provided on the enclosure with red color background with black lettering.
- (s.) Suitable for kVA Transformer shall be also printed in order to identify as to which rating of transformer the corresponding feeder pillar is designed for.
- (t.) 50 mm wide Horizontal strip of Fluorescent paint strip around paneling the middle of panel shall be made.

44.7. TESTS

All routine, acceptance & type tests shall be carried out in accordance with the relevant IS/IEC standards. The complete LT feeder panel shall be type tested in accordance with IEC 61439-i & 2. All routine & acceptance tests shall be witnessed by the purchaser / his authorized representative, if so desired. All the components as applicable shall be type tested as per the relevant standards. Following tests shall be necessarily conducted on the equipment in addition to others specified in IS/IEC standards

Type Tests AC3/MCCBs:

- (a.) Tripping Limits & Characteristics
- (b.) Operational & Overload Performance Capability
- (c.) Short Circuit Breaking/Making capacities
- (d.) Dielectric Properties test

Type Tests for Enclosure:

- (e.) Short circuit Test
- (f.) Temperature Rise Test
- (g.) Dielectric Properties test

(h.) Degree of Protection of enclosure

Routine Tests for ACB/MCCB:

(i.) Mechanical & electrical Operation

(j.) Calibration of Releases

(k.) Continuity of circuit.

(l.) Dielectric withstand.

Routine Tests for Enclosure:

(m.) Dielectric tests

(n.) Verification of clearances

(o.) Dimensional Checks

(p.) Demonstration for mounting arrangement with different makes of MCCB.

Acceptance Tests ACIEVIVICCBs:

(q.) Mechanical & electrical Operation

(r.) Calibration of Releases

(s.) Continuity of circuit.

(t.) Dielectric withstand

Acceptance Tests for Enclosure:

(u.) Dielectric tests

(v.) Verification of clearances

(w.) Dimensional Checks

(x.) Demonstration for mounting arrangement with different makes of MCCB Degree of Protection of enclosure

44.8. TYPE TEST CERTIFICATES

The bidder shall furnish the type test certificates for the tests as mentioned above as per the corresponding standards. All the tests shall be conducted NABL accredited test Labs such as CPRI, as per the relevant standards. Type tests should have been conducted in certified Test laboratories during the period not exceeding 5 years from the date of opening the bid.

However, Type Test certificated which are older than 5 years from date of bid opening, may be accepted as a special case, provided there is no change in

corresponding IS 1 IEC standards or MCCB design. In the event of any discrepancy in the test reports i.e. any test report not acceptable or any/all type tests (including additional type tests, if any) not carried out, same shall be carried out without any cost implication to DHBVN.

DHBVN has rights for Surveillance test of random selected samples from third party lab for quality checks of item.

44.9. PRE- DESPATCH INSPECTION

Equipment shall be subject to inspection by a duly authorized representative of the Purchaser. Inspection may be made at any stage of manufacture at the option of the purchaser and the equipment, if found unsatisfactory as to workmanship or material, the same is liable to rejection. Bidder shall grant free access to the places of manufacture to the Purchaser's representatives at all times when the work is in progress. Inspection by the Purchaser or its authorized representatives shall not relieve the bidder of his obligation of furnishing equipment in accordance with the specifications.

Material shall be dispatched after specific MDCC (Material Dispatch Clearance Certificate) is issued by the Purchaser.

Following documents shall be sent along with material :

- (a.) Test reports
- (b.) MDCC issued by Purchaser
- (c.) Invoice in duplicate
- (d.) Packing list
- (e.) Drawings & catalogue
- (f.) Guarantee / Warrantee card
- (g.) Delivery Challan
- (h.) Other Documents (as applicable)

44.10. INSPECTION AFTER RECEIPT AT STORE:

The material received at the Purchaser store shall be inspected for acceptance and shall be liable for rejection, if found different from the reports of the pre-dispatch inspection and one copy of the report shall be sent to each concerned Department.

44.11. GUARANTEE

Bidder shall stand guarantee towards design, materials, workmanship & quality of process / manufacturing of items under this contract for due and intended performance of the same, as an integrated product delivered under this contract. In the event any defect is found by the purchaser up to a period of at least 72 months from the date of commissioning of each lot made under the contract supplier/Bidder shall be liable to undertake to replace/rectify such defects at its own costs, within mutually agreed time frame, and to the entire satisfaction of the Company / purchaser, failing which the purchaser shall be at liberty to get it replaced/rectified at bidder's risks and costs and recover all such expenses plus the Company's own charges (© 20% of expenses incurred), from the bidder or from the " Security cum Performance Deposit" as the case may be.

Supplier/Bidder shall further be responsible for free replacement for another period of THREE years from the end of the guarantee period for any 'Latent Defects' if noticed and reported by the purchaser.

44.12. PACKING

Bidder shall ensure that all the equipment covered under this specification shall be prepared for rail/road transport (Local Equipment) and be packed in such a manner so as to protect the equipment from damage in transit.

The material used for packing shall be environmentally friendly.

44.13. TENDER, SAMPLE, INSTALLATION INSTRUCTION

Instruction manual, covering the product features/ handling and installation etc. shall be Provided by the supplier in two sets along with soft copy.

44.14. QUALITY CONTROL

The bidder shall submit with the offer Quality Assurance Plan indicating the various stages of inspection, the tests and checks which will be carried out on the material of construction, components during manufacture and bought out items and fully assembled component and equipment after finishing. As part of the plan, a schedule for stage and final inspection within the parameters of the delivery schedule shall be furnished. The Purchaser's/ Consultant's engineer shall have free access to the manufacturer's/sub-supplier's works to carry out inspections

44.15. MINIMUM TESTING FACILITIES

Bidder shall have adequate in house testing facilities for carrying out all routine tests, acceptance tests as per relevant Indian /International standards.

44.16. MANUFACTURING ACTIVITIES

The successful bidder shall submit bar chart for various manufacturing activities clearly elaborating each stage, with quantity. This bar chart should be in line with the Quality assurance plan submitted with the offer. This bar chart shall be submitted within 15 days from the release of the order.

44.17. SPARES, ACCESSORIES AND TOOLS

Bidder shall provide a list of recommended spares with quantity and unit prices for 6 years of operation after commissioning. The bidder shall provide a list of complete set of accessories and tools required for erection & maintenance along with the installation procedure.

44.18. DRAWINGS:

All the ACB/MCCB along with busbar as mentioned in clause-4 above shall be in one enclosure (feeder pillar). The drawing of construction and arrangement of equipments shall be submitted by the bidder as per site conditions for approval from DHBVN. Following drawings & Documents shall be prepared by the supplier/bidder along with all the statutory requirements as per site requirement and shall be submitted after the award of the contract for approval and before supply of material:

- (a.) Completely filled-in Guaranteed Technical Parameters.
- (b.) General description of the equipment and all components including brochures
- (c.) General arrangement drawings.
- (d.) Dimensional drawings
- (e.) Schematic Diagram
- (f.) Bill of material
- (g.) Foundation Plan/ Mounting details
- (h.) Installation Instruction

- (i.) Manual/Catalogues and instruction for use
- (j.) Type Test Certificates ,Routine, and Acceptance test
- (k.) Experience List
- (l.) OA &QC Plan
- (m.) Manufacturing schedule and test schedule
- (n.) Transport/ Shipping dimension drawing

Bidder shall be subsequently provide four (4) complete sets of final drawings, one of which shall be auto positive suitable for reproduction, before the dispatch of the equipment. Soft copy (Compact Disk CD) of all the drawing, GTP, Test certificates shall be submitted after the final approval of the same to purchaser.

All the documents & drawings shall be in English language,

Instruction Manuals: Bidder shall furnish two softcopies (CD) and four (4) hard copies of nicely bound manuals (In English language) covering erection and maintenance instructions and all relevant information and drawings pertaining to the main equipment as well as auxiliary devices.

44.19. GUARANTEED TECHNICAL PARTICULARS:

S.No.	Particulars	Units	As furnished by vendor
A	MCCBs		
1	Type of MCCB		
2	Type of releases		
3	Make of MCCB offered		
4	Rated Current of MCCB	A	
5	Rated Operational Voltage of MCCB	V AC	
6	Rated Insulation Voltage(Ui) of AC WM cpB	V	
7	No. of Poles of MCCB	Nos.	
8	Utilization Category of MCCB	A /B	
9	Rated Impulse- withstand voltage (U imp) of ACB/MCCB	kV	
10	Rated Ultimate Short Ckt. Breaking capacity : Icu (kArms) of ACB/MCCB	kA	
11	Rated Service Short Ckt. Breaking capacity : Ics (kArms) —100 % of Icu of ACB/MCCB	kA	
12	Overloading current with time setting	%/Sec	
13	Short Circuit Release setting with time setting	m,sec	
14	Instantaneous setting	%	
15	Earth Fault Setting with time	% 1 m.sec	
16	Spreaders & Phase Barriers of ACB/MCCB	Yes	
B	Distribution Box		
17	Installation	O/D	

S.No.	Particulars	Units	As furnished by vendor
18	Sheet Thickness	Mm	
19	Base frame	Mm	
20	Bottom holes and cable entry/support	-	
21	Canopy and lifting lug	-	
22	Material of Bus bar	-	
23	Minimum Current Density of bus bar	A/mm ²	
24	Max. permissible temperature rise	-	
25	Min. Clearance between phases	Mm	
26	Min. Clearance between phase to earth	Mm	
27	Terminal shrouds	-	
28	Degree of Protection for Enclosure	IP 55	
29	Overall Dimensions	Mm	

23.0 SCHEDULES OF DEVIATIONS

The bidders shall set out all deviations from this specification, Clause by Clause in this schedule. Unless specifically mentioned in this schedule, the tender shall be deemed to confirm the purchaser's specifications.

(TO BE ENCLOSED WITH THE BID)

All deviations from this specification shall be set out by the Bidders, clause by Clause in this schedule. Unless specifically mentioned in this Schedule, the tender shall be deemed to confirm the purchaser's specifications:

S. No.	Clause No.	Details of deviation with justifications

We confirm that there are no deviations apart from those detailed above.

Seal of the Company:

Signature

Designation

45.1. TECHNICAL SPECIFICATION FOR
3PHASE 4 WIRE CT OPERATED FULLY STATIC AMI COMPATIBLE
TRI-VECTOR ENERGY METERS FOR STATIC CT OPERATED DT METERS

1.0 SCOPE

Design, manufacturing, testing, supply and delivery of AC, 3 Phase, 4 Wire, CT operated fully Static and AMI compatible Tri-Vector Energy Meters for measurement of different electrical parameters listed elsewhere in the document including Active Energy (kWh), Reactive Energy (kVArh), Apparent Energy (KVAH) etc. The detail scope is given below.

2.0 APPLICATION

a) On Distribution Transformers

3.0 STANDARDS TO WHICH METERS SHALL COMPLY

IS 15959:2011 "Data Exchange for Electricity Meter Reading, Tariff and Load Control —Companion Specification".

IS: 14697 /1999 (Reaffirmed 2004) Specification for "AC Static Transformer operated Watt Hour & VAR-Hour meters (class 0.2 S & 0.5S);

IS-15707 Specification for Testing, evaluation, installation & maintenance of AC Electricity Meters- Code of Practice.

The equipment meeting with the requirements of other authoritative standards, which ensure equal or better quality than the standard mentioned above, also shall be considered; in case of conflict related with communication protocol, IS 15959:2011 "Data Exchange for Electricity Meter Reading, Tariff and Load Control —Companion Specification" shall prevail upon. For conflict related with other parts of the specification, the order of priority shall be — i) This technical specification ii) IS: 14697 /1999 (reaffirmed 2004).

4.0 CLIMATIC CONDITIONS:-

The Static Energy Meter shall be suitable for satisfactorily working for the climatic conditions as defined above in point -3.

5.0 GENERAL TECHNICAL REQUIREMENTS

1.	TYPE	AMI Compatible Static, 3 Ph, 4 Wire Tri-Vector Energy Meter
2.	FREQUENCY	50 Hz \pm 5%
3.	ACCURACY CLASS	0.5S
4.	SECONDARY VOLTAGE	For distribution transformer - Suitable for operation from 415V Ph-Ph or 240 V Ph-N
5.	BASIC CURRENT (Ib)	-/5 Amps as per existing CT for distribution transformers

6.	MAXIMUM CONTINUOUS CURRENT	2.0 lb; Starting and Short time current shall be as per IS14697
7.	POWER CONSUMPTION	i) The active and apparent power consumption, in each voltage circuit, at reference voltage, reference temperature and reference frequency shall not exceed 1.5 W and 8 VA. ii) The apparent power taken by each current circuit, at basic current, reference frequency and reference temperature shall not exceed 1.0 VA
8.	POWER FACTOR	0.0 Lag -Unity- 0.0 Lead
9.	DESIGN	Meter shall be designed with application specific integrated circuit (ASIC) or micro controller; shall have no moving part; electronic components shall be assembled on printed circuit board using surface mounting technology; factory calibration using high accuracy (0.05 class) software based test bench.

6.0. CONSTRUCTIONAL REQUIREMENT/ METER COVER & SEALING ARRANGEMENT

6.1 METER CASE: The meter case & cover will either be ultrasonically welded or shall have push fit type arrangement with two no. polycarbonate seals, of good quality, one each on either side, so that meter's internal parts are only accessible after breaking seals, ultrasonic welding, push fit arrangement or case cover of the meter and it should become unserviceable. The material for base and cover (transparent / translucent) of the meter shall be of Polycarbonate. The meter shall be factory calibrated and shall have unidirectional screws, fully embedded so that these cannot be unscrewed by means of pliers etc. for sealing. The meter case shall have at least three mounting holes. 2 holes for mounting screws, on the terminal block; sealed beneath the terminal cover and one for hanging screw on the top.

6.2 WINDOWS: -The meter cover shall be of Toughened Glass or Reinforced Polycarbonate material with one window. The window shall be of transparent material, ultrasonically welded with meter cover / part & parcel of meter cover so that it cannot be removed undamaged; without breaking the meter cover.

6.3 TERMINALS AND TERMINAL BLOCK: The terminals may be grouped in a terminal block having adequate insulating properties and mechanical strength. The terminal block shall be made from best quality non - hygroscopic, flame retardant material (capable of passing the flammability tests, as per IS - 11731) with nickel-plated brass or aluminium alloy for connecting terminals. The clamping screw should be provided inside the terminal cover and should have metallic sleeve molded within the block to avoid damage during tightening of the screws. The terminals in the terminal block shall be of adequate length in order to have proper grip of conductor with the help of two screws through agency of a plate so as to made cage type arrangement. The manner of fixing the conductors to the terminals shall ensure adequate and durable contact such that there is no risk of loosening or undue heating. Screw Connections, transmitting contact force and screw fixing, which may be loosened and tightened several times during the life of the meter, shall screw into a meter nut. All parts of each terminal shall be such that the risk of corrosion, resulting from contact with any other meter part, is minimized. Two screws shall be provided in each current terminal for effectively clamping the external leads or thimbles. Each clamping screw shall engage at least 3 threads in the terminal. The ends of screws shall be such as not to pierce the conductor. Electrical connections shall be so designed that the contact pressure is not transmitted through insulating material. For current circuits, the voltage is considered to be the same as for the related voltage circuit. The internal diameter of terminal holes shall be 5.5mm (min.) The clearances and creepage distances shall confirm to clause 6.6 of IS: 14697 /1999.

It shall conform to IS 11731 (FH-1 category) besides meeting the test requirement of heat deflection test as per ISO 75, glow wire test as per the IS:11000 (part 2/SEC1)1984 OR IEC PUB,60695-2-12, Ball

pressure test as per IEC--60695-10-2 and Flammability Test As per UL 94 or As per IS 11731(Part-2) 1986

6.4 TERMINAL COVER:- The terminal cover shall be extended type, which can be sealed independently of the meter cover. The terminal cover shall enclose the actual terminals; the conductor fixing screws, the external conductors and their insulation i.e. no part of meter or cable / accessories shall be visible from the front of the meter. When the meter is mounted, no access to the terminal shall be possible without breaking the seal (s) of the meter terminal cover. The terminal cover shall have at least two sealing screws. The fixing screws used on the terminal cover for fixing and sealing shall be kept captive in the terminal cover.

6.5 SEALING:-2 no unidirectional sealing screw shall be provided for proper fixing of meter cover with 2 no good quality polycarbonate seals, one each on either side, so that the meter internal parts are only accessible after breaking the seals, ultrasonic welding, push fit arrangement or case cover of the meter. Separate sealing arrangements shall be provided for MDI reset and communication port. In addition, the firm / supplier shall affix 2 no good quality, numbered hologram, on base and cover; one on each side and its record should be forwarded to the Nigam.

7.0 WORKING ENVIRONMENT

As per IS 14697-1999 (reaffirmed 2004). Meter to perform satisfactorily under Non-Air Conditioned environment (within stipulations of IS)

Meter body will conform to IP51 degree of protection. For outdoor use meter shall be installed in sealed enclosure conforming to IP 55.

The meter shall be suitable designed for satisfactory operation under the hot and hazardous tropical climate conditions and shall be dust and vermin proof. All the parts and surface, which are subject to corrosion, shall either be made of such material or shall be provided with such protective finish, which provided suitable protection to them from any injurious effect of excessive humidity.

8.0 MANUFACTURING PROCESS, ASSEMBLY AND TESTING

Meters shall be manufactured using latest and 'state of the art' technology and methods prevalent in electronics industry. The meter shall be made from high accuracy and reliable surface mount technology (SMT) components. All inward flow of major components and sub assembly parts (CT, PT, RTCs/Crystal, LCDs, LEDs, power circuit electronic components etc.) shall have batch and source identification. Multilayer 'PCB' assembly with 'PTH' (Plated through Hole) using surface mounted component shall have adequate track clearance for power circuits. SMT component shall be assembled using automatic 'pick-and-place' machines, Reflow Soldering oven, for stabilized setting of the components on 'PCB'. For soldered PCBs, cleaning and washing of cards, after wave soldering process is to be carried out as a standard practice. Assembly line of the manufacturing system shall have provision for testing of sub-assembled cards. Manual placing of components and soldering, to be minimized to items, which cannot be handled by automatic machine. Handling of 'PCB' with ICs/C-MOS components, to be restricted to bare minimum and precautions to prevent 'ESD' failure to be provided. Complete assembled and soldered PCB should undergo functional testing using computerized Automatic Test Equipment.

Fully assembled and finished meter shall undergo 'burn-in' test process for 12 hrs at 55 degree Celsius (Max. temperature not to exceed 60 degree Celsius) under base current (Ib) load condition.

Test points should be provided to check the performance of each block/stage of the meter circuitry. RTC shall be synchronized with NPL time at the time of manufacture. Meters testing at intermediate and final

stage shall be carried out with testing instruments, duly calibrated with reference standard, with traceability of source and date.

9.0 DISPLAYS

The meter shall have 7 digits (with \pm indication), parameter identifier, backlit Liquid Crystal Display (LCD) of minimum 10 mm height, wide viewing angle. Auto display cycling push button required with persistence time of 10 Seconds. LCD shall be suitable for temperature withstand of 70 deg C; Sequence of display of various instantaneous electrical parameters shall be as desired by Purchaser at the time of order.

The data stored in the meters shall not be lost in the event of power failure. The meter shall have Non Volatile Memory (NVM), which does not need any battery backup. The NVM shall have a minimum retention period of 10 years.

10.0 PERFORMANCE UNDER INFLUENCE QUANTITIES

The meters performance under influence quantities shall be governed by IS 14697:1999 (reaffirmed 2004), The accuracy of meter shall not exceed the permissible limits of accuracy as per standard IS: 14697 (latest version).

11.0 OUTPUT DEVICE

Energy Meter shall have test output, accessible from the front, and be capable of being monitored with suitable testing equipment while in operation at site. The operation indicator must be visible from the front and test output device shall be provided in the form of LED. Resolution of the test output device shall be sufficient to enable the starting current test in less than 10 minutes.

12.0 REAL TIME INTERNAL CLOCK (RTC)

RTC shall be pre-programmed for 30 Years Day/date without any necessity for correction. The maximum drift shall not exceed +/- 300 Seconds per year.

The clock day/date setting and synchronization shall only be possible through password/Keycode command from one of the following:

- (a.) Hand Held Unit (HHU) or Meter testing work bench and this shall need password enabling for meter;
- (b.) From remote server through suitable communication network or Sub-station data logger 'PC'.

13.0 QUANTITIES TO BE MEASURED & DISPLAYED

The meter shall be capable of measuring and displaying the following electrical quantities within specified accuracy limits for poly phase balanced or unbalanced loads:

a) Instantaneous Parameters such as phase and line voltages, currents, power factors, overall kVA, kW, kVAr, power factor, frequency etc as per Table 22 Instantaneous Parameters for Class A Meters as per IS 15959:2011

b) Block Load Survey Parameters such as kVAh/kWh/kVArh (lag/lead)/Maximum Demand(MD) in kW/kVA/power factor/phase and line voltages/currents etc (minimum 5 parameters) as per Table 23 Instantaneous Parameters for Class A Meters as per IS 15959:2011

In addition to above the meter shall also record the Name plate details, programmable parameters (readable as profile), occurrence and restoration of tamper events along with the parameters (Table 30 to Table 39 as per IS 15959:2011)

Detail of parameters requirement suitable for specific location such as DT metering is given in following table:

Category	Parameter Group	Table Reference No. as per IS 15959:2011
Distribution Transformer Meter	Instantaneous Parameter	Table 22
	Block Load Survey Parameters	Table 23
Distribution Transformer Meters	Name Plate Details	Table 30
	Programmable Parameters	Table 31
	Event Conditions	Table 32 to Table 38
Logging Parameters for each of the event condition- shall be selected	Capture parameters for event as applicable (Event Log Profile)	Table 39

14.0 DEMAND INTEGRATION PERIOD

The maximum demand integration period may be set at 15 minute or 30 minute by purchaser as per requirement.

15.0 MD RESET

It should be possible to reset MD by the following options:

- (a.) Communication driven reset
- (b.) Local push button
- (c.) Auto reset at 24:00 hrs at the end of each billing cycle

16.0 MARKING OF METERS

The marking of meters shall be in accordance with IS: 14697 /1999 (reaffirmed 2004). The meters shall bear marking "Purchased under XXXXX scheme/property of DHBVN/UHBVN".

The meter shall also store name plate details as given in the table 30 of IS 15959:2011. These shall be readable as a profile as and when required.

17.0 COMMUNICATION CAPABILITY

The meter shall be provided with two ports for communication of the measured/collected data as per IS 15959:2011, i.e. a hardware port compatible with RS 232/RS 485/any other type port based on the communication architecture and an Optical port complying with hardware specifications detailed in IEC-62056-21. Optical port shall be used for local data downloading through a DLMS compliant HHU. One-

meter long cable, of suitable size, having facility at one end, for connecting to the optical port, other end shall be provided with RS — 232 Connector shall be provided, as spare cable, so that the optical port can be brought out the meter box. The meter shall have

necessary facilities to transfer the data via the communication port to the hand held data collection device (DCD) and also to down load this on a P.0 to get complete details in numeric form. The necessary software for this purpose shall be provided by the supplier, without any condition, free of cost. Both ports shall support the default and minimum baud rate of 9600 bps.

18.0 TAMPER & FRAUD MONITORING FEATURES

The meter shall work satisfactorily under presence of various influencing conditions External Magnetic Field, Electromagnetic Field, Radio Frequency Interference, harmonic Distortion, Voltage/Frequency Fluctuations, and electromagnetic High Frequency Fields etc.

The meter shall be immune to abnormal voltage/frequency generating devices and shall record the occurrence and restoration of such tamper events along with parameters such as current, voltages, kWh, power factor, event code, date & time etc. (listed in Table 32 to 39 as per IS 15959:2011).

Tamper details shall be stored in internal memory for retrieval by authorized personnel through either of the following:

- (a.) HHU.
- (b.) Remote access through suitable communication network.

Minimum 200 numbers of events (occurrences & restoration with date & time) should be available in the meter memory.

19.0 TYPE TESTS

The meter offered should have successfully passed all type tests described in the IS 14697 and the meter Data Transfer and Communication capability as per IS 15959:2011. Type test certificate shall be submitted along with the offer and the same shall not be more than 36 months old at the time of bid submission. Make & type of major components used in the type-tested meter shall be indicated in the QAP. The bidder shall have to submit the required type test certificate (as per bid requirement) to the purchaser (utility) at the time of meters delivery.

Further Purchaser shall reserve the right to pick up energy meters at random from the lots offered and get the meter tested at third party lab i.e. CPRI / agencies listed at Appendix-C of Latest — standardization of AC static electrical energy meters — CBIP publication NO.-304/ NPL / CQAL/ ERTL / ERDA at the sole discretion of the Purchaser. The supplier has no right to contest the test results of the third party lab or for additional test and has to replace/take corrective action at the cost of the supplier. It shall be the responsibility of the supplier to arrange such tests and Purchaser shall be informed of the date and time of conduction of tests well in advance to enable him to witness such tests. Test charges of the testing authority, for such successful repeat type tests, shall be reimbursed at actual by the Purchaser.

20.0 ACCEPTANCE & ROUTINE TESTS

Criteria for selection for such tests and performance requirements shall be as per IS 14697-1999 (reaffirmed 2004)

Additional acceptance shall include Surge withstand (SWC) for 6 kVp as per IEC 62052-11, Lightning impulse test and HF disturbance test as per IS 14697. One sample meter per order from one of the offered lot shall be subjected to these specific tests. Meters subjected to these tests shall not be used after tests.

Accuracy tests shall be performed at the beginning and at the end of the acceptance tests specified.

21.0 QUALITY ASSURANCE:

The manufacturer shall have a comprehensive quality assurance program at all stages of manufacture for ensuring products giving reliable, trouble free performance. Details of the bidder's quality assurance and test set up shall be furnished with the bid. A detailed quality assurance program shall be finalized with the successful bidder during the award stage.

Bidder shall furnish following information along with his bid:

- (a.) Organization structure of the manufacturer and his main sub-suppliers (PCBs, SMT cards, CT/PT) with details of 'QA' setup, overall workflow;
- (b.) Copy of system manual showing 'QAP' (Quality Assurance Plan) as actually practiced during manufacturing and final testing.
- (c.) List of raw materials and critical components (ASIC chip, crystal clock, memory register Chip, transformers, optical ports etc.) with their suppliers;
- (d.) Stage inspection of product before final testing;
- (e.) Procedure adopted for 'In-situ' testing of PCBs, after placement of surface mounted component, for quantitative parametric variation of tolerance by self or sub-contractor.
- (f.) Testing and calibration facility, date of calibration of test bench, manpower data of bench operators;
- (g.) Sample copies of test certificate of bought out components.
- (h.) The manufacturer shall be responsible to pay penalty of Rs 20,000/- for each occasion at which the fake inspection call has been made or the material is rejected during testing/inspection by the authorized agency/representative of the Nigam. This penalty would be in addition to the expenses incurred by the Nigam in deputing the Inspecting Officer, carrying out such inspection.

22.0 GUARANTEE

The meter shall have a designed life of at least 10 years and the supplier shall be responsible to replace, free of cost, with no transportation or insurance - cost to the Nigam, up to destination, the whole or any part of the material which, under normal and proper use, proves defective in quality or workmanship, subject to the condition that the defect is noticed within 78 months from the date of receipt of material by the consignee or 72 months from the date of installation, whichever ever period may expire earlier. The consignee or any other officer of the Nigam, actually using the material, will give prompt notice of each such defect to the supplier as well as the Purchasing Authority and the Controller of Stores. The replacement shall be effected by the supplier within a reasonable time, but not, in any case, exceeding 45 days. The supplier shall also arrange to remove the defective supply within reasonable period but not exceeding 45 days from the date of issue of the notice in respect thereof. Upon the firm failing to do so, the damages / defects may be got rectified by the Nigam and the cost adjusted from the firm's pending dues and/or security deposit against this or any other contract in force and the balance left be got deposited by the supplier. The Nigam may withhold the amount, equal to cost of defective material. These provisions shall, also equally apply to the replaced material. In case, the material is again found to be

defective within warranty period, it shall, also, have to be replaced similarly. The purchaser shall recover an equivalent amount plus 15% supervision charges, if the defective material is not repaired / replaced with in the above specified period.

23.0 FIXING & CONNECTION ARRANGEMENT

Manufacturer shall ensure following technical points:

- i) Meter shall be suitable for mounting on Simplex type vertical panel with front door; CATM4 disconnecting type TBs to be used for Current circuit; Panel wiring to be properly dressed and harnessed; External cables to enter panel from bottom gland plate using double compression glands.
- ii) Meter installation & Inter-connection from existing CT/PT connections to energy meters in the panel shall be in the scope of contractor/bidder. The external cabling from existing CT/PT to Energy Meter panel shall be in the scope of purchaser.
- iii) Energy Meter terminals block shall be adequately sized with regard to maximum conductor dimension, commensurate with current rating of Energy Meter.

24.0 CHALLENGE CLAUSE:

The material offered/received after the inspection by the authorized Inspecting Officer may again be subjected to the test for losses or any other parameters from any testing house/in house technique of the Nigam having requisite capabilities and facilities. The results if found deviating/ unacceptable or non-complying to approved GTPs the lot shall be rejected and bidder shall arrange to supply the replacement within thirty (30) days of such detection at his cost including to & fro transportation. In addition to this penalty @10% of cost of the inspected lot of material shall be imposed.

Application Guide for us of this specification:

- i) The specification does not contain constructional details and method of sealing of meter cover and terminal sizes required for the purchaser’s incomer cables. This may be added suitably as per requirement of particular users. Quantities of meter require with/without meter cover need to be specify in bill of quantity in the specifications.
- ii) The specification shall suitably incorporate the appropriate qualifying requirement considering the quantity of meters intended to be procured.

GURANTEED TECHNICAL PARTICULAR FOR CT OPERATED TRIVECTOR METER

1	Maker’s Name	
2	Meter Make and Type	
3	Fixing Arrangement	
4	Basic current (Ampere)	
5	Rated maximum continuous current (Ampere)	
6	Standard reference voltage and frequency	
7	Class of accuracy	
8	Power loss in each	
	Voltage circuit	
	ii) Current circuit	
9	Minimum starting current	
10	Type of display	
11	No. of digit	
12	Type of output device	
13	Clearances and creepage distance in the	
	i. Terminal Block	

	40.11.1. cover	Terminal	
	40.11.2. parts of the meter	Internal	
14	Material of		
	i. Terminal Block		
	i. Terminal cover		
15	Material of terminals		
16	Material of Meter frame /covers		
17	Window arrangement and material		
18	Number of seals provided		
	i. Main Meter cover		
	i. Meter terminal cover		
19	Total weight of the meter		

46.1. TECHNICAL SPECIFICATION FOR MAINTENANCE FREE EARTH FOR ELECTRICAL INSTALLATION

1.0 SCOPE

This specification covers minimum requirements for design, engineering, manufacturer, installation and testing along with all necessary components like Copper bonded electrode, enhancing material & jointing / clamp used and procedure for constructing the earth-pit for maintenance free earthing system to ensure that the resistance value is less than 2 Ohms & remains consistent throughout its life with life expectancy of 35 to 40 years without any maintenance.

It is not the intent to specify all details of design and construction of the equipment/product. However the equipment / product offered shall conform to a high standard of design, engineering & workmanship and shall be capable of performing continuous commercial operation to the satisfaction of Nigam.

2.0 STANDARD

The product and the equipment covered by this specification shall, unless otherwise specified be in line with the requirement of any of the latest applicable standards and will apply in order of priority as listed below:-

- a) Indian Standards
- b) IEEE 80
- c) ANSI (American National Standards)
- d) IEC 62561-7
- e) Relevant BS (British Standards)

3.0 APPLICATIONS

Earthing systems covered in this document shall be for providing effective grounds for

- i) Grid Sub-Stations
- ii) DRC, supply control panels
- iii) Transformer neutral earths and GO Switches
- iv) Lightning arrester earths
- v) Meter Pillar Boxes housing energy meters

4.0 CLIMATIC CONDITIONS

The equipment/material to be supplied against this specification shall be suitable for satisfactory operation in under the following climatic Conditions.

D)	Location	At various locations in the state of Haryana
ii)	Max ambient temperature (deg.c) -	60
iii)	Min ambient air temperature (deg. c)	-5
iv)	Max average daily ambient temperature (deg. c)	40
v)	Max. yearly weighed average ambient temperature (deg. C)	32
vi)	Max. altitude above mean sea level (Meters)	1000
vii)	Minimum Relative Humidity (% age)	26
viii)	Max. Relative Humidity (%age)	95
ix)	Avg. no of Rainy days/ year	120
x)	Avg. annual rainfall	900mm
xi)	Maximum wind pressure	195 Kg./mm Sq.

The equipment shall be for use in moderately hot and humid tropical climate conducive to rust and fungus growth.

5.0 SELECTION OF EARTH SYSTEM

S. N.	Installations/ Current Capacity	IR Value Required	Soil Type/ Resistivity	Earth System	
1	House hold earthing/ 3kA	8 ohm	Normal Soil/ upto 50 ohm-mtr	Single Electrode	
			Sandy Soil/ between 50 to 2000 ohm-mtr		
			Rocky Soil/ More than 2000 ohm-mtr	Multiple Electrodes	
3	Commercial premises Office buildings/ 5kA	2 ohm	Normal Soil/ upto 50 ohm-mtr	Single Electrode	
			Sandy Soil/ upto 2000 ohm-mtr	Multiple Electrodes	
			Rocky Soil/ More than 2000 ohm-mtr	Multiple Electrodes	
	Transformers, substation earthing, LT line equipment / 15kA		1 - 2 ohm	Normal Soil/ upto 50 ohm-mtr	Single Electrode
				Sandy Soil/ upto 2000 ohm-mtr	Multiple Electrodes
				Rocky Soil/ More than 2000 ohm-mtr	Multiple Electrodes
4	Transformers, substation	less than 1 ohm	Normal Soil/ upto 50 ohm-mtr	Single Electrode	

S. N.	Installations/ Current Capacity	IR Value Required	Soil Type/ Resistivity	Earth System
	earthing, HT line equipment/ 40kA		Sandy Soil/ upto 2000 ohm-mtr	Multiple Electrodes
			Rocky Soil/ More than 2000 ohm-mtr	Multiple Electrodes
5	Lightning arresters, extra high current applications etc. 50kA	less than 1 ohm	Normal Soil/ upto 50 ohm-mtr	Single Electrode
			Sandy Soil/ upto 2000 ohm-mtr	Multiple Electrodes
			Rocky Soil/ More than 2000 ohm-mtr	Multiple Electrodes
6,	PRS, UTS, RTUS,FOIS. COIS, ATMs and data processing centre etc./5KA	less than 0.5 ohm	Normal Soil/ upto 50 ohm-mtr	Single Electrode
			Sandy Soil/ upto 2000 ohm-mtr	Multiple Electrodes
			Rocky Soil/ More than 2000 ohm-mtr	Multiple Electrodes

6.0 LOCATION OF EARTH ELECTRODE

These earthing electrodes along with ground enhancing material & clamp would be installed in a pit near to distribution transformers, meter pillar boxes, grid sub-station, earthing for lighting arrestor etc.

7.0 EARTHING SYSTEM

The earthing system includes Copper bonded electrode, ground enhancing material (GEM) and ground rod clamps detailed as follows:-

7.1 Copper Bonded Earth Rods

7.1.1 The Earth Rods shall have a nominal (actual) dia of 5/8" (14.2mm) and length of 10 feet: (3M). The Rods shall have a steel core with molecular bonding of 250 micron of Copper

7.1.2 The core used shall be 1035 steel cold drawn to ASTM A 1080 and AISI C 1017 standards with tensile strength min 90000 psi

7.1.3 A nickel layer is applied to steel core (and subsequently copper) by an electrolytic process forming a metallurgical bond between the three. The copper used shall be type DHP alloy No. 122 CDR and rated at 99.95% copper. The thickness of copper layer shall be uniform 0.010" (250 micron)

7.1 4 The Earth Rod shall be UL(Under Writers laboratory) listed and should have the UL mark, part number and control number assigned by UL.

7.2 Ground Enhancement Material GEM

7.2 1 Ground Enhancement Material shall be permanent and maintenance free (no re-charging with salts or any other chemicals) and shall maintain its earth resistance with time.

7.2 2 It must set up firmly and not dissolve or decompose or otherwise pollute the soil or the local water table,

- 7.2.3 It shall be suitable for use in dry form or slurry form.
- 7.2.4 The Ground Enhancement Material shall not depend on the continuous presence of water or moisture in the surrounding to maintain its conductivity.
- 7.2.5 Ground Enhancement Material in its set form shall have a resistivity of not more than 0.08 ohm per m.
- 7.2.6 The material should conform to IEC 62561 Part-7 Requirement of Earthing Enhancing Compound.
- 7.2.7 Material should pass leaching per EN 12457-2 method.
- 7.2.8 Material should pass Sulphur per ISO 14869-1 method.
- 7.2.9 Material should pass Corrosion as per ASTM G59-97 and G102-89 method.
- 7.2.10 It shall not depend on the continuous presence of water to maintain its conductivity.
- 7.2.11 It should be a little alkaline in nature with pH value >7 but <9, test certificate from NABL approved laboratory to be provided for the composition so designed.
- 7.2.12 It should have better hygroscopic properties to absorb moisture. It should absorb and release the moisture in dry weather condition and help in maintaining the moisture around the earth electrode.
- 7.2.13 It should have capacity to retain >10% moisture at 105°C. Test certificate from NABL approved lab to be submitted for the composition so designed.
- 7.2.14 It should have water solubility < 5%. Test certificate from NABL approved lab to be submitted for the composition so designed.
- 7.2.15 It should be granular with granule size 0.1 mm to 3 mm.
- 7.2.16 It should be non toxic, non reactive, non explosive & non corrosive.
- 7.2.17 It shall be thermally stable between -10 degree centigrade to +60 degree centigrade ambient temperature.
- 7.2.18 It shall not decompose or leach out with time.
- 7.2.19 It shall not pollute the soil or local water table and meets environmental friendly requirement for landfill.
- 7.2.20 It should expand & swell considerably and removes entrapped air to create strong connection between earth electrode and soil.
- 7.2.21 It should be diffused into soil pores and creates conductive roots enlarging conductive zone at earth pit.
- 7.2.22 It shall be permanent & maintenance free and in its "set, form" maintains constant earth resistance with time.
- 7.2.23 It shall not require periodic charging treatment or replacement.
- 7.2.24 It shall be suitable for any kind of electrode and all kinds of soils of different resistivity.

7.2.25 It shall not cause burns, irritation to eye, skin etc.

7.2.26 The Earth enhancement material shall be supplied in sealed, moisture proof bags. These bags shall be marked with Manufacturer's name or trade name, quantity, batch no & date of manufacture

8.0 MARKING :

The marking shall be clear, distinct and visible to the naked eye from a distance of about 1 meter: the size of marking shall be of minimum 25 mm, Following information shall be legibly and indelibly marked on the packed sets:

- a) Specification no.
- b) Name of the manufacturer
- c) Batch no. & Date of manufacturer
- d) Current carrying capacity

9.0 TESTS

Following tests shall be done on one sample-

9.1 Testing of copper coating shall be done as described below:-

i) The copper coating mentioned in clause 8.1 shall not be less than the prescribed thickness at any point and shall comply with the adherence requirement in para (ii) & (iii) below.

ii) Length of the electrode with one end cut to a 45 degree point shall be driven between two steel clamping plates or the jaws of a vise set 0.04 in (1.02 mm) less than the diameter of the electrode, so as to shear off sufficient metal to expose the bond between the copper coating and electrode. Peeling of the coating by the steel plates or the jaws of the vise is acceptable, but there shall be no other evidence of separation of the coating from the metal core.

iii) At room temperature, a length of the electrode is rigidly held in a clamp or vise and the free end is bent by applying a force normal to the electrode at a distance from the clamping device equal to 40 times the diameter. The magnitude of the force and the direction of application of force shall be such that the electrode is permanently bent through a 30-degree angle. While bending of the electrode there shall be no evidence of cracking of the copper coating.

9.3 Corrosion Test : As per IS.2119, salt spray test for analysis of effect of

corrosion for the specific electrode shall be done through NABL approved testing lab, preferably for 500 hrs. or more.

9.4 Exothermic weld material shall be tested as per provisions of IEEE 837

9.5 Electrical properties test on conductive mixture

9.6 Physical, chemical & electrical properties test on earth enhancement material

9.6.1 Toxic content tests for cadmium, lead, mercury, hexavalent chromium, polybrominated biphenyls (PBBs) & polybrominated diphenyl ethers (PBDEs) on conductive mixture & earth enhancement material.

Certificates from NABL approved laboratories shall be submitted with test results of above tests. Test certificates shall not be more than three years old.

For dimension, weight and specific resistance average of 3 readings shall be taken. Average value shall be within specified limits and individual values shall not go beyond double of tolerances.

10.0 ACCEPTANCE TESTS

10.1 Following shall constitute acceptance tests and shall be done on 100% sample basis for all the tests mentioned below except where otherwise indicated—

- (a.) Physical check for earth electrode for rod type electrode.
- (b.) Earth enhancement material
- (c.) Earth resistance measurements

11.0 Rejection:

In case the any component tested and inspected in accordance with this specification, fails to pass the tests or comply with the requirement of the specification, another two component from the same lot shall be inspected in accordance with the specification and if one of them also fail to pass the test, the whole lot of that component shall be rejected subject to the discretion of the purchaser or his nominee.

12.0 INSPECTION:

All the gauges/ test & measuring instruments shall be under calibration control at the time of inspection and proof to this office shall be produced.

Inspection and testing shall be carried out by the inspecting authority nominated by the purchaser to ensure that all the requirements of this specification are complied with for the acceptance of the materials offered by the supplier for inspection

The purchaser or his nominee shall have right of free access to the works of the manufacturer and to be present at all reasonable times and shall be given facilities by the manufacturer to inspect the manufacturing process at any stage of manufacture. He shall have the right to reject whole or part of any work or material that does not conform to the terms of this specification or any other specification or requirement applicable and may order the same to be removed / replaced or altered at the expense of the manufacturer. All reasonable/complete facilities considered necessary by inspecting authorities for the inspection shall be supplied by the manufacturer free of cost.

The manufacturer shall at his own cost prepare and furnish the necessary test pieces and appliances for such testing as may be carried out at his own premises in accordance with the specification. Failing the existence of facilities at his own premises for the prescribed tests, the manufacturer shall bear the cost of carrying out the tests in an approved laboratory, workshop or test house.

13.0 FAKE INSPECTION CALLS

The manufacturer shall be responsible to pay penalty of Rs 20,000/-for each occasion at which the fake inspection call has been made or the material is rejected during testing/inspection by the authorized agency/representative of the Nigam. This penalty would be in addition to the expenses incurred by the Nigam in deputing the Inspecting Officer, carrying out such inspection.

14.0 CHALLENGE CLAUSE: -

The material offered/received after the inspection by the authorized inspecting officer may again be subjected to the test for any parameter from any Testing House/in-house technique of the Nigam & the results if found deviating un-acceptable or not complying to approved GTP's the bidder shall arrange to supply the replacement within thirty (30) days of such detection at his cost including to & fro transportation. In addition to this penalty ©10% of cost of the inspected lot of material shall be imposed

15.0 INFRINGEMENT OF PATENT RIGHTS:

Nigam shall not be responsible for infringement of patent rights arising due to similarity in design, manufacturing process, use of the components, used in design, development and manufacturing of escalator and any other factor which may cause such dispute. The responsibility to settle any issue lies with the manufacturer.

16 0 GUARANTEED TECHNICAL PARTICULARS

The guaranteed technical particulars of the equipment / material supplied shall be given by the tenderer as per Annexure-E9 along with the tender Tenders without GTPS shall be out rightly rejected

ANNEXURE "E9"

SCHEDULE OF GUARANTEED AND OTHER TECHNICAL PARTICULARS

Sr. No.	Description of feature / parameter	Technical value / magnitude
1	Copper Bonded Earth Rods	
1.1	Actual Nominal Dia of earth rod (mm / Inches)	
1.2	Length of earth rod (Feet / mm)	
1.3	Value of molecular copper bonding in Microns	
1.4	Core of Steel used with Tensile Strength (psi)	
1.5 2 -	Whether UL (Under Writers) Laboratory enlisted Ground Enhancing Material (GEM)	Yes/ No
2.1	Resistivity (Ohm -- Meters)	-
2.2	pH Value (Whether > 7 but < 9)	
2.3	Capacity (in %) to maintain moisture at 105°C	
2.4	Water solubility (in %)-	
2.5 2.6 2.7 2.8 2.9	Granule Size (mm) Whether toxic, non reactive, non-explosive and non-corrosive Whether environment friendly i.e. does not pollute soil or local water table Suitable for copper wounded electrode Whether requires periodic charging equipment or replacement	Yes/ No Yes / No Yes / No

INSTALLATION PROCEDURE:-

Auger a 3 inch hole to a depth equal to 6 inches less than the rod length . Drop the rod down the hole with the low end centered and driven in 6 inches. Fill the hole using premixed (Slurry) GEM material.

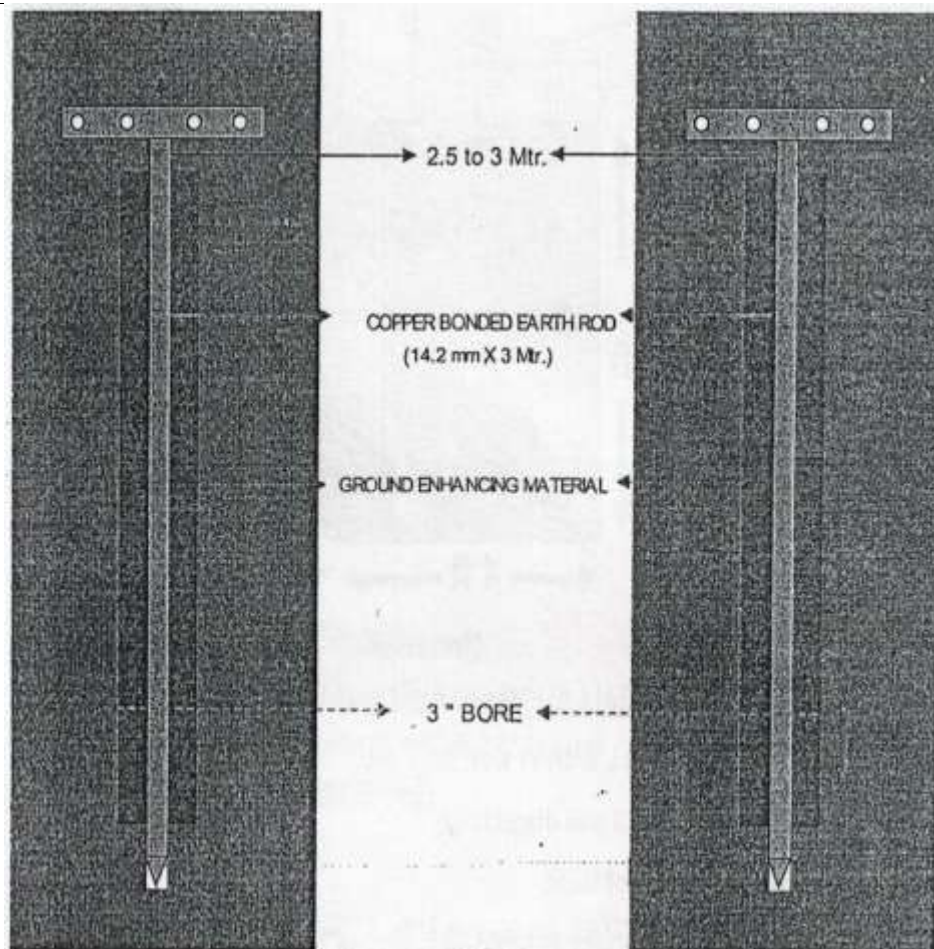

TRENCH INSTALLATION FOR -7: EARTHING SYSTEM

PROCEDURE FOR INSTALLATION :-

- 1 Dig a trench of 10 ft L X 0ft W X 5ft D.
2. Fill up with compact soil diagonally,
3. Spread out a layer of GEM.
- 4 Place the rod diagonally as shown,

----SOIL

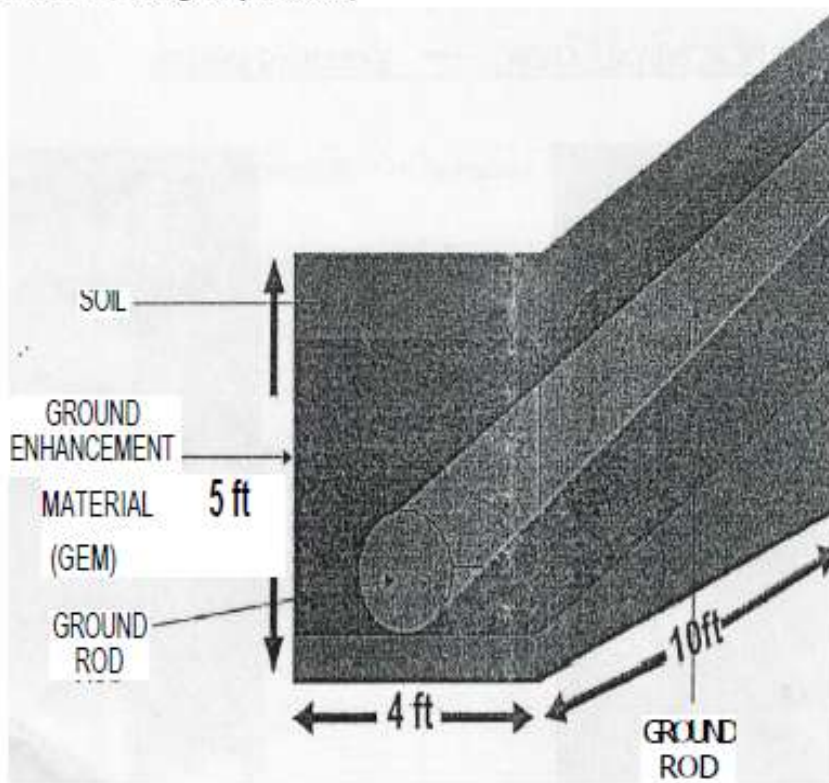

5. Cover the entire length of rod with premixed (Slurry) GEM.
6. Fill up the trench with compact soil.

.GROUND
ENHANCEMENT
MATERIAL
(GEM)

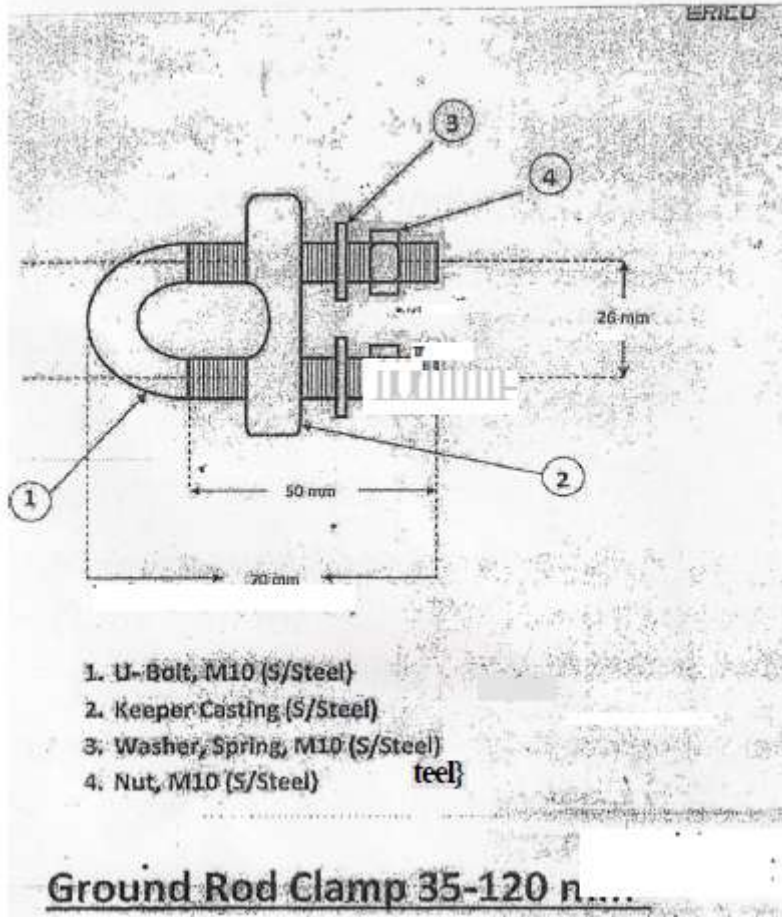

47.1. TECHNICAL SPECIFICATION OF LED STREET LIGHTS

1.0 SCOPE

This specification covers minimum requirements for design, engineering, manufacturer, installation and testing along with all necessary components including LED Luminaries, poles, remote controlling of the system etc.

Faridabad Smart City Limited (FSCL), a special purpose vehicle has been formed for designing, developing, managing and execution of the Smart City Project. FSCL has planned to install LED street lights in Faridabad City in selected area.

Scope of work under this section shall include inspection at supplier's/manufacturer's premises, appropriate, receiving at site, safe storage, transportation from point of storage to point of erection and installation of light fittings, fixtures and accessories including all necessary supports, brackets, down rods and painting as required. The contractor shall supply all materials and accessories, labour, tools, transportation, scaffolding etc., required for the completion of above work in all respects. Type of fixtures / lamps shall be as specified in the BOQ

2. REQUIREMENT OF LED LAMPS

Sodium vapour lamps are normally used for street illuminations. Life of (burning hours) this lamp is much less than LED lamps. Adopting use of LED lamps for illumination has advantage because of low electricity requirement. Burning hours of LED lamps are much higher as compared to FTL, Metal Halide and sodium vapour lamps. This reduces maintenance cost.

Energy consumed by the LED lighting is much less as compared to the sodium vapour lighting. This will reduce the energy bill of street lights to great extent. LED lamps have long life as compared to conventional lamps. Cost of LED lamps is higher but due to long burning hours and saving in electricity, overall there is a benefit in changing the lamps to LED type.

1. APPLICABLE STANDARDS:

The lighting and their associated accessories such as lamps, reflectors, housings, ballasts etc., shall comply with the latest applicable standards, more specifically the following

Luminaires: Part 5 Particular requirements, Section 3 Luminaires for road and street lighting (superseding IS:2149)	IS 10322: Part 5 : Sec 3
Code of practice for interior Illumination	IS - 3646 (All 3 parts)
Electric light fittings General and safety requirements	IS - 1913
Decorative lighting outposts	IS - 5077
Luminaires for street lighting	IS - 2149
Performing measurement of LEDs	LM-79
Water proof electric lighting fitting	IS-3528
Steel Tubes, Tubulars and Other Wrought Steel Fittings - Specification - Part 1 : Steel Tubes	IS-1239: part 1
Mild steel tubes, tubulars and other wrought steel fittings, Part 2 Mild steel tubulars and other wrought steel pipe fittings	IS-1239: part 2
Specification for Tubular Steel Poles for Overhead Power Lines	IS 2713: Parts 1 to 3
Water tight electric lighting fittings	IS 3553
Code of practice for lighting public thoroughfares	

Indian Electricity Act, 2003 and IE Rules, 1956 as amended	
Regulations laid down by the Chief Electrical Inspector	
Any other regulations laid down by the Local Authorities	

5. GENERAL REQUIREMENTS:

Fixtures shall be designed for continuous trouble free operation under atmospheric conditions, reduction in lamp life or without deterioration of materials and internal wiring. Outdoor fittings shall be weather - proof and rain proof

All fixtures shall be supplied with lamps and complete with accessories and fixings necessary for installation whether so detailed under fixture description or not.

Fixtures shall be so designed as to facilitate easy maintenance including cleaning, replacement of lamps/starters etc. Fixtures shall be installed at mounting heights as detailed on the drawings or instructed on site by the The Engineers/ Employer's representative.

Detailed catalogue for all fixtures, or, if so required by the The Engineers/ Employer's representative sample fixtures shall be submitted for approval to the The Engineers/ Employer's representative before orders for the fixtures are placed. Shop drawings for non-standard fixture types shall be submitted for approval to the The Engineers/ Employer's representative.

The fixture should conform to applicable IS 10322 / IEC60598 (Allparts & amendments) and should have the associated LM-79 and LM-80 report from a recognized lab. Test reports shall be submitted along with relevant catalogs.

6. LED LAMP

- (a.) LED Efficacy at the chip level shall be >120 lumen /watt (For High power LED)
- (b.) The efficiency of the LED lamp at 85 Degree C junction temperatures shall be more than 85%.
- (c.) The luminous efficacy of LED luminaire shall be at least 90 lumen / Watt for low wattage luminaires (<45 W system – including driver losses) and at least 95 lumen/watt for high wattage luminaires (>45 W system – including driver losses) at about 350 miliamps or so. On higher driving current higher output is expected without compromising the life of LEDs. The products showing more duration of L70 would be preferred.
- (d.) Adequate heat sink with proper thermal management shall be provided.
- (e.) Power factor of complete fitting shall be more than 0.90 at full load 220-240 V.
- (f.) LED shall be surface mounted type duly soldered to PCB by Reflow system. The Solder used shall be ROHS compatible for environment friendliness.
- (g.) Input frequency range shall be between $50\text{Hz} \pm 3\%$.
- (h.) Color rendering index (CRI) shall be at least 70 for both indoor and outdoor applications.
- (i.) Correlated color temperature shall ranged between 4000 to 6500 K.
- (j.) Minimum view angle of the LED shall not be less than 120°

7. LED DRIVER:

LED driver shall have following features:

- (a.) Input voltage range within 160V(RMS) to 270 V(RMS)

- (b.) Driver shall be designed to withstand surges of at least 1.5 KV.
- (c.) Operating input voltage 220-240V (RMS)
- (d.) Output voltage of the driver shall be designed to meet the power requirements of the system.
- (e.) Input voltage ripple should be within 3%
- (f.) Output over voltage protection 125 VDC
- (g.) Power factor > 0.90
- (h.) Full Load Efficiency $\geq 85\%$
- (i.) Total Harmonic Distortion (THD) shall be < 25 %
- (j.) Current wave form should meet EN 61000-3-2
- (k.) LED Driver should possess overvoltage cut off protection for supply over 270V AC.
- (l.) The driver should comply to CISPR15 for limit and methods of measurement of Radio Disturbance characteristics
- (m.) The equipment should comply to IEC 61547 for EMC immunity requirements
- (n.) The control gear should be compliant to IEC 61347-2-13, IEC 62031 and IEC 62384.

8. GENERAL :

The lumen maintenance of the LED fixtures shall not be less than 70% after 50,000 hours (Unless specified otherwise in the detailed specifications).

The supplier shall provide evidence that the LED chip set manufacturer has the patent right to produce the supplied LED chipset to avoid infringement of white LED patent. Warranty shall be provided by the supplier against all manufacturing defects for a period of 48 months from the date of supply or 24 months from the date of commissioning whichever is earlier. The warranty of replaced item shall re-start from date of attending defect / replaced.

The lighting supplier shall be a manufacturer of at least two components from luminaire, lamps (conventional or LED) & control gear. At least two of the above mentioned components shall be from a single manufacturer to ensure continuity of spare supplies. The lighting supplier shall necessarily have been present in India for at least 10 years with an annual turnover of at least 100 crores in each of the last 3 years to ensure adequate solvency. The lighting supplier shall also have necessarily supplied fixtures to Metro projects globally.

Test reports from various parameters i.e. lux, power, efficacy, chromaticity, temperature, protection etc. Issued by certified agency shall be furnished. Estimation on product's life and performance shall also be furnished.

9. TESTS:

Tests

Tests to be done:

- a) Type test: Type tests shall be carried out to prove confirmation with the requirement of specification and general quality/design features of the unit by the firm on particular models of the luminaire. Necessary

type test reports from NABL or ISO accredited Laboratory must be available with the firm & shall be submitted to The Engineers/ Employer's representative for Notice of No Objection.

b) Acceptance Tests: These tests are carried in the presence of The Engineers/ Employer's Representative at the supplier's premises on sample taken from a lot for the purpose of acceptance of a lot. The luminaries shall be selected from the lot at random. Sample size shall be as per mutual agreement between supplier and client/client representative.

Sr. No.	Description of Test	Type Test	Acceptance Test
1.	Visual and Dimensional Check	Y	Y
2.	Resistance to humidity	Y	-
3.	Insulation resistance test	Y	Y
4.	HV test	Y	Y
5.	Over voltage protection	Y	-
6.	Surge Protection	Y	-
7.	Reverse polarity	Y	Y
8.	Temperature rise Test	Y	-
9.	Color rendering Index measurement test	Y	Y
10	Photometry Test (LM79)	Y	Y
11	Fire Retardant test	Y	-
14	Test for IP protection	Y	Y
15	Environmental Test	Y	-
16	Reliability Test	Y	-
17	Life Test	Y	-
18	Endurance Test	Y	-
19	Torsion Test	Y	-
20	Emission of radio frequency disturbances	Y	-
21	Harmonics	Y	Y
22	Vibration test	Y	-

10. POLES:

Testing and Commissioning

The lighting installation shall be tested as per approved schedule and the instructions of Engineer and shall include but not be limited to the following:

Insulation resistance of each circuit shall be measured without the lamps being in place. It should not be less than 500000 ohms to earth.

Current and voltage of all the outdoor lighting circuits shall be measured at the Main Distribution Board with all the lamps switched on to ensure that these are within designed values and in the case of 3-phase circuits, the load shall be balanced if required.

Earth continuity shall be checked for all the circuits.

After inserting all the lamps and switching on all the circuits, minimum and maximum illumination levels shall be measured in all areas and their conformity with designed levels established. The test results shall be entered in the approved pre-commissioning proforma and submitted to the Engineer for approval before final commissioning.

11. CENTRALIZED STREET LIGHTING CONTROL

Smart LED street lighting system has facility to adopt centralized control system. This system offers following Merits –

- a. Central control, fault detection
- b. Generation of burn hours reports
- c. Automatic operation with astronomical timers

- d. Manual operation from a central location through GPRS / GSM system
- e. Dimming operation
- f. Remote metering
- g. Voltage stabilization

12. Guarantee and Warranty

The Bidder shall stand guarantee for the performance of entire equipment and components for twelve (12) months from the date of commissioning or eighteen (18) months from the date of dispatch.

SECTION 8: ANNEXURES

PART A: Annexure A to O

ANNEXURE- "A"

MODEL RULES RELATING TO LABOUR, WATER SUPPLY AND SANITATION IN LABOUR CAMPS

Note: These model rules are intended primarily for labour camps which are not of a permanent nature. They lay down the minimum desirable standard which should be adhered to Standards in Permanent or semi-permanent labour camps should not obviously be lower than those for temporary camps.

- 1. Location:** The camp should be located in elevated and well drained ground in the locality.
- 2. Labour:** Huts are to be constructed for one family of 05 persons each. The layout is to be shown in the prescribed sketch.
- 3. Hut line:** The huts to be built of local materials. Each hut should provide at least **20 Sqm.** of living space.
- 4. Sanitary facilities:** There shall be provision of latrines and urinals at least **15 M** away from the nearest quarter separately, for men and women specially so marked.
- 5. Latrines:** Pit provided at the rate of 10 users or three families per set. Separate Urinals as required as the privy can also be used for this purpose.
- 6. Drinking water:** Adequate arrangement shall be made for the supply of drinking water. If practicable, filtered and chlorinated supply shall be arranged. Where supply is from intermittent sources, an overhead covered storage tank shall be provided with a capacity of five litres per person per day. Where the supply is to be made from a well it shall conform to the sanitary standards laid down in the report of the Rural Sanitation Committee. The well should be at least 30 meters away from any latrine or other sources of pollution. If possible a hand pump should be installed for drawing the water from well. The well should be effectively disinfected once every month and quality of water should be got tested at Public Health institution between each work of disinfection. Washing and bathing should be strictly prohibited at places where water supply is from a river. The daily supply must be disinfected. In the storage reservoir and given at least 3 minutes contact with the disinfectant before it is drawn for use.
- 7. Bathing and Washing:** Separate bathing and washing place shall be provided for men and women for every **25 persons** in the camp. There shall be a gap and space of **2 Sqm.** for washing and bathing. Proper drainage for waste water should be provided.
- 8. Waste disposal:** Dustbins shall be provided at suitably place in camp and the residents shall be directed to throw all rubbish into these dustbins. The dustbins shall be provided with covers. The contents shall be removed every day and disposed of by trenching or through Municipal solid waste disposal system, if the same exists.
- 9. Medical facilities.**
 - a) Every camp where **1000 or more persons** reside shall be provided with full time doctor and dispensary. If there are women in the camp a full time nurse shall be employed.
 - b) Every camp where less than 1000 but more than 250 persons reside shall be provided with dispensary and a part time nurse/midwife shall also be employed.
 - c) If there are less than 250 persons in any camp a first aid kit shall be maintained by the in- charge of the whole time persons. All medical facilities mentioned above shall be for all residents in the camp, including a dependent of the workers, if any, free of cost. Sanitary Staff: For each labour camp there should be qualified sanitary Inspector & Sweepers should be provided in the following scale:
 1. For Camps with strength over 200 One Sweeper for every 75 persons but not exceeding 500 persons above the first 200 for which three sweepers should be provided.

2. For camps with strength over 500 One sweeper for every 100 persons above the first 500 for which six Sweepers should be provided.

ANNEXURE – “B”

COMPLIANCE WITH LABOUR REGULATIONS

During continuance of the contract, the Contractor and his sub-contractors shall abide at all times by all existing labour enactments and rules made there under, regulations, notifications and bye laws of the State or the Central Government or the local authority and any other labour law (including rules), regulations, bye laws that may be passed or notification that may be issued under any labour law in future either by the State or the Central Government or the local authority. Salient features of some of the major labour laws that are applicable to construction industry are given below. The Contractor shall keep the Employer indemnified in case any action is taken against the Employer by the competent authority on account of contravention of any of the provisions of any Act or rules made there under, regulations or notifications including amendments. If the Employer is caused to pay or reimburse, such amounts as may be necessary to cause or observe, or for non-observance of the provisions stipulated in the notifications/bye laws/Acts/Rule/regulations including amendments, if, any on the part of the Contractor, the Engineer/Employer shall have the right to deduct any money due to the Contractor including his amount of performance security. The Employer/Engineer shall also have right to recover from the Contractor any sum required or estimated to be required for making good the loss or damage suffered by the Employer.

The employees of the Contractor and the Sub-Contractor in no case shall be treated as the employees of the Employer at any point of time.

SALIENT FEATURES OF SOME MAJOR LABOUR LAWS APPLICABLE TO ESTABLISHMENTS ENGAGED IN BUILDING AND OTHER CONSTRUCTION WORK.

- a) Workmen Compensation Act 1923:- The Act provides for compensation in case of injury by accident arising out of and during the course of employment.
- b) Payment of Gratuity Act 1972 :- Gratuity is payable to an employee under the Act on satisfaction of certain conditions on separation if an employee has completed 5 years service or more on death, the rate of 15 days wages for every completed year of service. The Act is applicable to all establishments employing 10 or more employees.
- c) Employees P.F. and Miscellaneous Provision Act 1952 :- The Act Provides for monthly contributions by the Employer per workers @ 10% or 8.33%. The benefits payable under the Act are:
 - (i) Pension or family pension on retirement or death, as the case may be.
 - (ii) Deposit linked insurance on the death in harness of the worker.

- (iii) Payment of P.F. accumulation or retirement/death etc.
- d) Maternity Benefit Act 1951 :- The Act provides for leave and some other benefits to women employees in case of confinement or miscarriage etc.
- e) Contract Labour (Regulation & Abolition) Act 1970 :- The Act provides for certain welfare measures to be provided by the Contractor to contract labour and in case the Contractor fails to provide, the same are required to be provided, by the Principal Employer by Law. The principal Employer is required to take Certificate or Registration and the Contractor is required to take license from the designated Officer. The Act is applicable to the establishments or Contractor of Principal Employer, if they employ 20 or more contract labour.
- f) Minimum Wages Act 1948 :- The Employer is supposed to pay not less than the Minimum Wages fixed by appropriate Government as per provisions of the Act, if the employment is a scheduled employment. Construction of Buildings, Roads, Runways are scheduled employments.
- g) Payment of Wages Act 1936 :- It lays down as to by what date the wages are to be paid, when it will be paid and what deductions can be made from the wages of the workers.
- h) Equal Remuneration Act 1979 :- The Act provides for payments of equal wages for work of equal nature to Male and Female workers and for not making discrimination against Female employees in the matters of transfers, training and promotions etc.
- i) Payment of Bonus Act 1965: - Deleted
- j) Industrial Disputes Act 1947 :- The Act lays down the machinery and procedure for resolution of Industrial disputes, in what situations a strike or lock-out becomes illegal and what are the requirements for laying off or retrenching the employees or closing down the establishment.
- k) Industrial Employment (Standing Orders) Act 1946 :- It is applicable to all establishments employing 100 or more workmen (employment size reduced by some of the States and Central Government to 50). The Act provides for laying down rules governing the conditions of employment by the Employer on matters provided in the Act and get the same certified by the designated Authority.
- l) Trade Unions Act 1926 :- The Act lays down the procedure for registration of trade unions of workmen and employers. The Trade Unions registered under the Act have been given certain immunities from civil and criminal liabilities.
- m) Child Labour (Prohibition & Regulation) Act 1986 :- The Act prohibits employment of children below 14 years of age in certain occupations and processes and provides for regulation of employment of children in all other occupations and processes. Employment of Child Labour is prohibited in Building and Construction Industry.

- n) Inter-State Migrant workmen's (Regulation of Employment & Conditions of Service) Act 1979 :- The Act is applicable to an establishment which employs 5 or more inter-state migrant workmen through an intermediary (who has recruited workmen in one state for employment in the establishment situated in another state). The Inter-State migrant workmen, in an establishment to which this Act becomes applicable, are required to be provided certain facilities such as housing, medical aid, traveling expenses from home upto the establishment and back, etc.
- o) The Building and Other Construction workers (Regulation of Employment and Conditions of Service) Act 1996 and the Cess Act of 1996 :- All the establishments who carry on any building or other construction work and employs 10 or more workers are covered under this Act. All such establishments are required to pay cess at the rate not exceeding 2% of the cost of construction as may be modified by the Government. The Employer of the establishment is required to provide safety measures at the Building or construction work and other welfare measures, such as Canteens, First-Aid facilities, Ambulance, Housing accommodations for workers near the work place etc. The Employer to whom the Act applies has to obtain a registration certificate from the Registering Officer appointed by the Government.
- p) Factories Act 1948 :- The Act lays down the procedure for approval of plans before setting up a factory, health and safety provisions, welfare provisions, working hours, annual earned leave and rendering information regarding accidents or dangerous occurrences to designated authorities. It is applicable to premises employing 10 persons or more with aid of power or 20 or more persons without the aid of power engaged in manufacturing process.

Annexure C-I:

(Irrevocable Bank Guarantee Bond) (GUARANTEE BOND)

(In lieu of performance Security Deposit) (To be used by approved Scheduled bank)

PERFORMANCE BANK GUARANTEE

To

Faridabad Smart City Limited, B K Chowk, NIT,
Faridabad, Haryana - 121001

WHEREAS _____ [name and address of Contractor] (hereafter called "the Contractor") has undertaken, in pursuance of **Tender No.** _____ dated _____ to execute _____ [name of **Tender** and brief description of Works] (hereinafter called " the Contract").

AND WHEREAS it has been stipulated by you in the said Contract that the Contractor shall furnish you with a Bank Guarantee by a recognized bank for the sum specified therein as security for compliance with his obligation in accordance with the Contract;

AND WHEREAS we have agreed to give the Contractor such a Bank Guarantee:

NOW THEREFORE we hereby affirm that we are the Guarantor and responsible to you on behalf of the Contractor, up to a total of _____ [amount of guarantee]* _____ (in words), such sum being payable in the types and proportions of currencies in which the Contract Price is payable, and we undertake to pay you, upon your first written demand and without cavil or argument, any sum or sums within the limits of _____ [amount of guarantee] as aforesaid without your needing to prove or to show grounds or reasons for your demand for the sum specified therein.

We hereby waive the necessity of your demanding the said debt from the contractor before presenting us with the demand.

We further agree that no change or addition to or other modification of the terms of the Contract or of the Works to be performed thereunder or of any of the Contract documents which may be made between you and the Contractor shall in any way release us from any liability under this guarantee, and we hereby waive notice of any such change, addition or modification.

This guarantee shall be valid until 28 days from the date of expiry of the Defect Liability Period.

Signature and Seal of the guarantor _____

Name of Bank _____

Address _____

Date _____

Annexure C-II

To,

.....
.....
.....

Dear Sir,

We enclose Demand Draft / Bank Guarantee/Cash Certificate other similar instrument no. for in favour of Designation of the Officer concerned in lieu of deposits required from for the due fulfilment by him/them of the terms of Bidder dated..... for during the period commencing from there of if any.

Yours faithfully,

For and on behalf.

Annexure C-III

(To be used by approved Scheduled bank)

BANK GUARANTEE FOR ADVANCE PAYMENT

To

Faridabad Smart City Limited.

B K Chowk, NIT Faridabad, Haryana - 121001

_____ [name of Contractor]

Gentlemen :

In accordance with the provisions of the ,Section -5, General Conditions of Contract, Clause No 47 (iii) (“ Mobilization Advance ”) of the above-mentioned Contract, [name and address of Contractor] (hereinafter called “the Contractor”) shall deposit with Faridabad Smart City Limited a bank guarantee to guarantee his proper and faithful performance under the said Clause of the Contract in an amount of _____[amount of Guarantee]* _____ [in words].

We, the _____ [bank of financial institution], as instructed by the Contractor, agree unconditionally and irrevocably to guarantee as primary obligator and not as Surety merely, the payment to Faridabad Smart City Limited on his first demand without whatsoever right of obligation on our part and without his first claim to the Contractor, in the amount not exceeding _____ [amount of guarantee]* _____ [in words].

We further agree that no change or addition to or other modification of terms of the Contractor or Works to be performed thereunder or of any of the Contract documents which may be made between **Faridabad Smart City Limited** and the Contractor, shall in any way release us from any liability under this guarantee, and we hereby waive notice of any such change, addition or modification.

This guarantee shall remain valid and in full effect from the date of the advance payment under the Contract until **Faridabad Smart City Ltd.** receives full repayment of the same amount from the Contractor.

Yours truly,

Signature and Seal of the guarantor _____

Name of Bank _____

Address _____

Date _____

ANNEXURE-D
SAFETY CODE

1. Scaffolding:

(i) Suitable scaffold should be provided for workman for all works that cannot safely be done from the grounds or from solid construction except such short period work as can be done safely from ladder is used on extra labour shall be engaged for holding the ladder for carrying materials as well suitable foot holes and hand holds shall be provided on the ladder and the ladder shall be given an inclination not steeper than $\frac{1}{4}$ to $\frac{1}{4}$ Horizontal and 1 vertical).

(ii) Scaffolding or staging more than 12 M above, the ground floor swung or suspended from an overhead support or erected with stationer/support shall have a guard rail property attached, bolted, braced or otherwise secured at least 1 meter high above the floor platforms of such scaffolding or staging and extending along the entire length of the outside the ends thereof with only such opening as may be necessary for the delivery of the materials. Such scaffolding or staging shall be fastened as to prevent it from swaying from the building of structure.

(iii) Working platform gangways and stairway should be so constructed that they should not away unduly or unequally and if the height of the platform of the Gangway or the stairway is more than 3.54 meters above ground level and or floor level they should be closely bearded, should have adequate width and should be suitably fenced as described (ii) above.

(iv) Working platform be provided with suitable means to prevent the falling of persons or materials by providing suitable fencing or railing whose minimum height shall be 1 meter.

(v) Safe means of access shall be provided to all working platforms and other working places. Every ladder shall be securely fixed. No portable ladder shall be over 9 meter in length while the width between side rails in ring ladder shall be in no case be less than 0.3 meters from ladder up to and including 3 meter length. For longer ladders this width should be increased at least 2 cm. For each additional meter of length. Uniform step spacing shall not exceed 0.3 M adequate precaution shall be taken to prevent danger form electrical equipment. No material on any of the work site shall be so stacked or placed as to cause danger or inconvenience to any person or the public. The Bidder shall also provide all necessary fencing and lights to protect the public from accident and shall be bound to bear the expenses of defence of every suit action or other precautions of law that may be brought by any person for injury sustained owing to neglect of the above and to pay any damages and costs which may be awarded in any such suit action or proceeding to any such person or which may with consent of the Bidder be paid to compromise by any such person.

2 Excavation and Trenching: All trenches 1.2 meter or more in depth, shall at all times be supplied with at least one ladder for each 30 Meter in length or fraction thereof. Ladder shall be extended from bottom of the trench to at least 1 meter above the surface of the ground. The side of trenches which are 1.5 meter or more in depth shall be stepped back to give suitable slopes or securely held by timber bracing so as to avoid the danger of sides to collapse The excavated materials shall not be placed within 1.5 meter of the edge of the trench or half of the depth of the trench whichever is more. Cutting shall be done from top to bottom. Under no circumstances undermining or under cutting shall be done.

3 Demolition: Before any demolition work is commenced and also during the process of the works.

(a) All roads and open area adjacent to the work site shall either be closed or suitably protected.

(b) No electric cable or apparatus which is liable to be a source of danger over a cable or apparatus used by the operator shall remain electrically charged.

(c) All precautionary steps shall be taken to prevent danger to persons employed from risk of fire or explosion of flooring. No floor roof or other part of the building shall be so overloaded with debris of materials as to render it unsafe.

4 Painting: All necessary personal safety equipment as considered adequate by the Engineer-in-charge should be kept available for the use of person employed on the site and maintained in a condition suitable for immediate use and the Bidder should take adequate steps to ensure proper use of equipment by those concerned.

- a) Workers employed on mixing asphaltic materials cement lime mortars shall be provided with protective footwear and. protective goggles.
- b) Stone brackets shall be provided with protective goggles and protective clothing, and seated at sufficiently safe intervals.
- c) Those engaged in welding works shall be provided with welder's protect.
- d) When workers are employed in sewers and manholes which are in use, the Bidders shall ensure that the manhole covers are open and are ventilated at least for an hour before the work shall be coronet off with suitable railing and provided with warning signals or boards to prevent accident to the public.
- e) The Bidder shall not employ men below the age of 19 and women on the work of painting with products containing lead in any form whenever men above the age of 18 are employed on the work of lead painting the following precautions should be taken.
- f) No paint containing lead or lead shall be used except in the form of paste or readymade paint.
- i) Suitable face masks should be supplied for use by the workers when paint applied in the form of spray or a surface having lead paint dry rubble and scrapped.
- ii) Overhauled shall be supplied by the Bidder to the workman and adequate facilities shall be provided to enable the working painters to wash during the cessations of work.

5. Drawing: When the work is done near any place where there is risk a drawing of all necessary equipment should be provided and kept ready for use and all necessary steps taken for prompt rescue of any person in danger and adequate provision should be made for prompt first aid treatment for all injuries likely to be sustained during the course of the work.

6. Every crane driver or hosing equipment operator shall be properly qualified and should not have any personal disorder. Such person must be of a minimum age of 21 years.

- a) In case of every hoisting machine and every chain ring lowering or as means of suspensions. The safe working load shall be ascertained by adequate means. Every hoisting machine and gear referred to above shall be plainly marked with the safe working load. In case of hoisting machine having a variable safe working load of the conditions under which it is applicable shall be clearly indicated. No part of any machine or of any gear referred to above in this paragraph shall be loaded beyond the safe working load except for load purpose of testing.
- b) In case of departmental machine the safe working and load shall be notified by the Electrical Engineer-in-charge. As regarded Bidder's machine the Bidder shall notify the safe working load of the machine to the Engineer-in-charge, whenever he brings any machinery to site of work and get verified by the Electrical Engineer concerned.
- c) Motors, gearing transmission, Electric wiring and other dangerous part of the hoisting appliance should be provided with efficient safe guards and with such means as well reduce adequate precautions should be taken to reduce to the minimum the risk of any part of a suspended load be coming accidentally displaced When workers employed on Electrical installations which are already unregistered insulating mats wearing apparel such as gloves sleeves and boots as may be necessary should be provided the workers should not wear rings, watches and carry keys, or other materials which are good conductors of electricity.

7. All scaffolds, ladders and their safety device mentioned or described herein shall be maintained in safe condition and no scaffold ladder or equipment shall be altered or removed while it is in use. Adequate washing facilities shall be provided at or near places of work.

8. These safety provisions should be brought to the notice of all concerned by display on a Notice Board at prominent places at the work spot. The persons responsible for compliance of the safety code shall be named therein by the Bidder.
9. To ensure effective endorsement of the rules and regulations relating to safety precautions the arrangement made by the Bidder shall be open to inspection by the Labour Officer, Engineer-in-charge, or the Department or their representatives.
10. Notwithstanding the above clause (1) to (9) there is nothing in these three except the Bidders to exclude the operations of any other act or rule in force in the Republic of India.
11. The bidder has to place the safety sign board in the work area which should be properly visible to prevent any accident.
12. The bidder has to take 3rd party Insurance of the work area, equipment(s), Tools and Tackles.
13. The bidder shall keep the Safety Engineer / Officer who shall take care for safety related issues and shall be present on work area on full time basis during construction work.

ANNEXURE – E

List showing the name of near relative working in FSCL as required vide

S. No.	Name of Officers working in FSCL,	Relationship with self	Name of Person working with the Bidder who are near relative to officer mentioned in column(2)	Relationship
1	2	3	4	5

ANNEXURE-F

GENERAL SPECIFICATION

1. The successful Bidder shall carry out the construction of Smart Road for ABD area as per the approved drawings which shall be provided by FSCL. All norms of IS/NBC shall be fully complied. Before commencing construction work the successful bidder shall submit the construction plan to FSCL. The Authority shall study all such submissions and either approve the same or provide its suggestions or comments on the submissions. The successful bidder shall duly incorporate all such suggestions or comments, and if required by the Authority, and make fresh submissions to the Authority for approval. In no case shall any work be commenced by the successful bidder before obtaining all necessary approvals from the Authority. The bidder shall always commence the construction work as per Approved drawings provided by FSCL.

All designs must fully take into account conditions/terms stipulated in Section 2: Instruction to Bidders, Or any other conditions mentioned elsewhere in the Tender document.

2. It is to be noted that the works are in the ABD area of the proposed smart city and as such is prone to many challenges from the residents and users. The bidder shall cooperate with the FSCL in resolving the challenges.

3. The Smart Road works shall be constructed in such a way that it will not damage the existing facilities and the entire existing operations function normally.

General Specifications:

All material should be ISI mark / ISO 9000 accredited company or manufactured by Public sector/Govt. Owned Companies or of the firms of repute. However Govt. / Public Sector makes are preferred makes. It is necessary to mention make of equipment Bidder intends to use. If Bidder does not mention make, the Owner would be free to mention the make of his choice.

Notes:

1. Complete copies of the drawings & Designs must be submitted by the successful bidder for obtaining approval of the Authority before commencing works.

2. General specification for work following order of priority regarding specification for work shall be followed by the Bidder.

(i) Relevant B.I.S. Specification.

(ii) Specifications as may be given in writing by the Engineer-in-charge from time to time.

(iii) C P.W.D / Haryana P.W.D. specification/N.B.O./MORTH.

3. Nothing in these clauses, however, shall curtail the right of the “Engineer-In- Charge” to alter the specification for any part or whole of the work, if he considers it necessary in the interest of work. On all matters where there is a deference of opinion between the Bidder and the Engineer-In-Charge the matter will be referred to the Chief Executive Officer, FSCL whose decision will be final conclusive and binding on the Bidder.

4. The Bidder shall ensure the quality and workmanship of work as per approved drawings.

5. The existing development should not be damaged by the successful Bidder and he should hand them back as in original constructed condition.

6. Materials to be get approved before providing, execution and installation from the Engineer-in- charge. Further the bidder shall provide Ready Mix Challan clearly indicating the mix time, cement quantity, setting times, etc.
7. **The Bidder shall supply manufacturing certificates along with the supply of materials.**

LIST OF APPROVED MANUFACTURERS / MAKES

All material should be ISI mark / ISO 9000 accredited company or manufactured by Public sector/Govt. owned Companies or of the firms of repute. However Govt. / Public Sector makes are preferred makes. It is necessary to mention make of equipment Bidder intends to use. If Bidder does not mention make, the Owner would be free to mention the make of his choice.

S.No.	MATERIAL	MAKE
1	Structural/Reinforcement Steel:	SAIL/TATA/RINL/JINDAL
2	Stainless Steel:	SAIL/TATA/RINL/JINDAL
3	GI Pipes	ZENITH /TATA/JINDAL
4	Cement:	ACC/Ultra tech/Century/Lafarge/Ambuja
5	UPVC pipes / HDPE Pipes/LLDP	Astral / Finolex / Prince / Supreme
6	Ready/Mixed concrete	ACC/L&T/Ultratech/RMC/Godrej
7	Cables	Polycab / Finolex / RPG / Gemscab /Havells / KEI
8	LED Light	Havells / Philips / Bajaj
9	Light Pole	Havells / Philips / Bajaj
10	Distribution Board & Switchgears	L&T /LEGRAND /SIEMENS/ABB
11	Poly Carbonate Sheet	LEXAN/GALLINA/TUFLITE
12	Water Proofing Compound	FOSROC/SIKA/PIDILITE/
13	Paints	ASIAN / BERGER/ NEROLAC
14	Interlocking Paver Block	NILITE CONCRETE/PAVERS INDIA/NIMCO
15	Water Fountain Nozzles	PREMIER / RIPPLE

ANNEXURE G: TESTING & SPECIFICATION OF MATERIAL

FOR WORKS:

i) Rates include the element of testing of samples of various materials brought by the Bidder for use in the work as per list of mandatory tests attached herewith. Frequency of such tests to be carried out shall not be less than the prescribed frequency. Bidder shall arrange a third party testing agency which shall be approved by the Engineer-in-charge. The tests shall have to be conducted by the Bidder's material under the supervision of Engineer-in-charge or his authorized representative. A record of such tests shall be maintained in a duplicate register at site of work Duplicate copies of such tests shall be submitted to office along with running account bills. The original register shall also be submitted along with the final bill. Failure to conduct any of the test or not up to the prescribed frequencies would invite following consequences. The Engineer-in-charge may reject the work, but if in his opinion the work can be accepted despite the aforesaid shortcomings, then he may do so subject to a recovery of money to be decided by the E in C for each default and simultaneously inform the Chief Executive Officer.

ii) Wherever applicable As regards steel reinforcement; TMT Steel – confirming to IS-1786:2008 shall be provided.

All reinforcement shall be free from loose mill scales, loose rust and coats of paints, oil, mud or other costing which may destroy or reduce bond.

Only such steel as is obtained from main producers of steel as indicated in the approved makes list.

The Bidder shall have to produce Test Certificate in the Performa prescribed/ approved by B.I.S. from the manufacturer for every batch of steel brought to site of work.

Before commencement of use of steel, from any batch, brought to site of work by the Bidder, the Engineer-in-charge shall arrange to get samples tested for nominal mass, tensile strength, bend test and rebind test from any Laboratory of his choice at the cost of Bidder. The selection of test specimens and frequency shall be as per relevant I.S. Specification of steel to be used.

iii)

here, contract provides for cement to be arranged by the Bidder himself, only M25 Grade and above cement of relevant I.S. standard specifications shall be allowed to be used in the work subject to the following tests. The arrangement for necessary equipment and testing shall have to be made by the Bidder, himself at a site to be decided by the Engineer-in-charge. All expenses shall be borne by the Bidder. Any lot of cement brought to site by the Bidder would be permitted to be used in the work under the supervision of the Engineer-in-charge or his authority's representative. The record of the tests results shall be maintained in the register referred in subsequent Para.

iv)

Type of Test	Frequency	Minimum
a) Test for initial & final /setting time as per IS: 4031 (Part 5)-1988.	1st Test for 10 tonnes or part thereof	10 tonnes
b) Test for determination of compressive strength of cement as per IS: 4031 (Part 6)-1988.	1st test for 50 tonnes or part	

A Duplicate register as per format hereunder shall be maintained at site of work. Extract certified copies of the entries for each month shall be submitted to the Engineer-in-charge by the Bidder. The original register shall also be submitted to the Engineer-in-charge on completion of the work by the Bidder.

S. No	Place of receipt of cement	No. of bags	Name and Address of firm From whom Purchased	Signature of Bidder or his authorized representative	Signature of authorized representative of Engineer-in-charge	Results of test for initial and final setting	Result of tests for compressive strength	Remark
1	2	3	4	5	6	7	8	9

When the strength of concrete required is up to M-20, then O.P.C. conforming to I.S.: 269-2013 or PPC conforming to IS: 1498-1976 may be used.

When the strength of concrete required is more than M-20 but up M-30, the O.P.C. Conforming to IS: 8112-2013 shall be used.

Nominal mix would be adopted for Cement concrete M-7.5 M-10 and M-15. Design mix shall have to be adopted for concrete of higher strengths.

iv) If any item of work found to be substandard by the Engineer-in-charge who is the opinion that the same is structurally adequate and can be accepted at a reduced rate, then in such cases, the Engineer- in-charge shall have to submit proposals for appropriate reduction of rates supported by an analysis, in justification thereof, though a D.O. Letter to the commissioner to obtain his approval expeditiously (ordinarily within 15 days). The approved analysis along with orders of the Chief Executive Officer shall have to be appended to the bills of the Bidder.

v) The Bidder shall have to be provided a ruled duplicate register at site named “Site Order Book” it shall be in the custody of departmental supervisory staff. The Engineer-in-charge or his authorized representative may record their instruction in this book, which shall be noted by the Bidder or his authorized representative for compliance.

vi) Ready mix concrete :The bidder shall have to supply the ready-mixed concrete on either of the following basis :

i) Specified strength based on 28-day compressive strength of 15 -cm cubes tested in accordance with IS : 456-2000.

ii) Specified mix proportion.

NOTE: Under special circumstances and as specified the strength of concrete in (a) above may be based on 28-day or 7-day flexural strength of concrete instead of compressive strength of 15-cm cube tested in accordance with IS : 456-2000.

When the concrete is manufactured and supplied on the basis of specified strength, the responsibility for the design of mix shall be that of the manufacturer and the concrete shall conform to the requirements specified.

When the concrete is manufactured and supplied on the basis of specified mix proportions, the responsibility for the design of the mix shall be that of the purchaser and the concrete shall conform to the requirements specified.

Pipes: The length of pipes shall be measured in running meter nearest to a centimetre along the center line of the pipes over all fittings such as collars, bends, junctions etc. Fittings/specials shall not be measured separately.

UPVC PIPES : The pipes shall be round and shall be supplied in straight lengths with socketed ends. The internal and external surfaces of pipes shall be smooth, clean, free from groovings and other defects. The

ends shall be cleanly cut and square with the axis of the pipe. The pipes shall be designed by external diameter and shall conform to IS:4985-1981 or IS:13592. The pipes shall be of Class-III; 6 Kg/sqm pressure rating or type B.

Fittings

Fittings shall be of the same make as that of pipes, injection moulded and shall conform to IS:14735.

List of mandatory Tests:

Material	Test	Relevant IS code of testing	Field/ Laboratory Test	Minimum Quantity of material work for Carrying out test.	Frequency of Testing
1	2	3	4	5	6
Cement concrete or reinforced cement concrete not leaner than M-15	Slump Test	IS: 1199	Field	15 Cum or more	15 Cum or part there of frequently by Engineer In charge
Reinforced cement concrete	Cube strength	For Building IS; 456, for bridges/ Culverts IRC: 21-1987	Field	15 Cum in slab 5 cum on Columns.	15 Cum
Steel (arranged by the Bidder)	a)Tensile strength	IS: 1608	Laboratory	20 tonnes	Every 20 tonne thereof conforming to IS: 1786-1985
	b) Bend test	IS: 1599	Laboratory	-do-	--do
Cement (arranged by the Bidder)	a) Test for Initial &Final setting.	IS: 4031-Part 5	Field	10 tonnes	IS: 4031-1988
	b) Test for determination of compressive strength of Cement.	IS: 4031 Part 6	Field	50 tonnes	-do-

List of mandatory Tests:

Material	Test	Relevant IS code of testing	Field/ Laboratory Test	Minimum Quantity of material work for Carrying out test.	Frequency of Testing
1	2	3	4	5	6
Sand	a) Silt content.	IS:2386 Part III	Field		Every 20 cum or part or more frequently as by the Engineer-in charge. Every 20 Cum or part or more frequently as by the Engineer-in charge. -do
	b) Particle size distribution	IS: 2386 Part I	Field		
	c) Bulking of sand	IS: 2386 Part III	Field		
Stone Aggregate	a) Percentage of soft or deleterious material.		Central visual inspection, laboratory test where required by the Eng.-in-charge Or as Specified.	0.00 Cum	As required Engineer-in-charge.
Ready Mixed Cement (IS-4926) concrete	Cube test	IS 516 and as per 6.3.2 of IS 4926-2003	Lab	50 Cum	On eper every 50 cum of production or every 50

List of mandatory Tests:

Material	Test	Relevant IS code of testing	Field/ Laboratory Test	Minimum Quantity of material work for Carrying out test.	Frequency of Testing
1	2	3	4	5	6
					batches, whichever is greater frequency
RCC Spun Pipes (NP-3 class)	a) water test and leak test at joints		visual inspection	Water test with minimum head 1.2m and maximum 1.8 m	Check for head drop in the pipe for duration of 2 hrs. Check for the leakages at Joints.
Water for construction purposes	Ph value Limits of acidity percentage of soilds choliorides suspended matter sulphates in organic soilds and organic soilds	IS 3025	Lab	Water from each source	Before commencement of work & there after mandatory-Once in 3 months from each source,Municipal supply - Optional

List of mandatory Tests:					
Material	Test	Relevant IS code of testing	Field/ Laboratory Test	Minimum Quantity of material work for Carrying out test.	Frequency of Testing
1	2	3	4	5	6
UPVC pipes	Entire drainage system shall be tested for water tightness and smoke tightness during and after completion of the installation. No portion of the system shall remain untested. Contractor must have adequate number of expandable rubber bellow plugs, manometers, smoke testing machines, pipe and fitting work tests,		Visual inspection	Water test with minimum head 1.2m and maximum 1.8	Check for head drop in the pipe for duration of 2 hrs. Check for the leakages at Joints.

Location of Proposed Smart Road in ABD in Faridabad City

ANNEXURE-H

AFFIDAVIT (SELF CERTIFIED)

(On company's Original Letter head)

I, Mr/Ms.....S/o /
D/o.....
Aged.....years.....(Address
.....
.....)
(For and on behalf of),

I hereby certify that ESIC does not apply for our Firm.

(.....)
Authorized signatory / for and on behalf of
.....
(Affix seal)

ANNEXURE-I

POWER OF ATTORNEY

(On Rs. 100 Stamp Paper duly notarized on all pages)

Power of Attorney for Authorized Representative

The firm M/s.....authorize the following Representative to sign and submit the tender document, negotiate terms and conditions for the contract, to sign the contract, to deal with the _____, to issue and receive correspondence related to all matters of the tender “-----”. We / M/s _____ undertake the responsibility due to any act of the representative appointed hear by.

For Partnership Firm's

S .No.	Name of All Partner	Signature of Partner with Seal
1		
2		
3		
4	Name and Designation of the person Authorized	
5	Attested Signature of the Authorized Representative	

For Limited Firm's

Name and Designation of the person Authorized	
Firm	
Address	
Telephone No.	
Mobile No.	
Authority By which the Powers is delegated	
Attested Signature of the Authorized Representative	
Name and Designation of person attesting the signatures	

ANNEXURE-J

Format for Joint Bidding MOU for Consortium (To be executed on Stamp paper of (appropriate value))

THIS JOINT BIDDING MOU is entered into on this the day of 20...

AMONGST

1. { Limited, and having its registered office at} (hereinafter referred to as the "First Part" which expression shall, unless repugnant to the context include its successors and permitted assigns)

AND

2. { Limited, having its registered office at} and (hereinafter referred to as the "Second Part" which expression shall, unless repugnant to the context include its successors and permitted assigns)

AND

3. { Limited, and having its registered office at} (hereinafter referred to as the "**Third Part**" which expression shall unless repugnant to the context include its successors and permitted assigns)

The above mentioned parties of the FIRST, {SECOND and THIRD} PART are collectively referred to as the "**Parties**" and each is individually referred to as a "**Party**"

WHEREAS,

- A. FARIDABAD SMART CITY LIMITED, established under the companies Act 2013, represented by its Chief Executive Officer and having its principal offices at Nain Sadan, 3rd Floor, Plot No. 35, Sector 20A, Faridabad, Haryana - 121001, (hereinafter referred to as the "Authority" which expression shall. Unless repugnant to the context or meaning thereof, include its administrators, successors and assigns) has invited bids (the Bids") by its BID No..... date..... (the "BID") for award of contract for (Name of the Project ******) on Annuity Payment Mode (the Project").
- B. The Parties are interested in jointly bidding for the Project as members of a Consortium and in accordance with the terms and conditions of the BID document and other bid documents in respect of the Project, and
- C. It is a necessary condition under the BID document that the members of the Consortium shall enter into a Joint Bidding MOU and furnish a copy thereof with the Bid.
NOW IT IS HEREBY AGREED as follows

1. Definitions and Interpretations

In this MOU, the capitalized terms shall, unless the context otherwise requires, have the meaning ascribed thereto under the BID.

2. Consortium

2.1 The Parties do hereby irrevocably constitute a Consortium (the "Consortium") for the purposes of jointly participating in the Bidding Process for the Project.

2.2 The Parties hereby undertake to participate in the Bidding Process only through this Consortium and not individually and/ or through any other Consortium constituted for this Project, either directly or indirectly or through any of their Associates.

3. Role of the Parties

The Parties hereby should declare their respective roles and responsibilities that shall be undertaken during the course of the contract period in their BID's.

4. Joint and Several Liability

The Parties do hereby undertake to be jointly and severally responsible for all obligations and liabilities relating to the Project and in accordance with the terms of the BID.

5. Representation of the Parties

Each Party represents to the other Parties as of the date of this MOU that:

- (a) Such Party is duly organized, validly existing and in good standing under the laws of its incorporation and has all requisite power and authority to enter into this MOU;
- (b) The execution, delivery and performance by such Party of this MOU has been authorized by all necessary and appropriate corporate or governmental action and a copy of the extract of the charter documents and board resolution/ power of attorney in favor of the person executing this MOU for the delegation of power and authority to execute this MOU on behalf of the Consortium Member is annexed to this MOU, and will not, to the best of its knowledge:
 - (i) require any consent or approval not already obtained;
 - (ii) Violate any Applicable Law presently in effect and having applicability to it;
 - (iii) Violate the memorandum and articles of association, by-laws or other Applicable organizational documents thereof;
 - (iv) Violate any clearance, permit, concession, grant, license or other governmental authorization, approval, judgment, order or decree or any mortgage agreement, indenture or any other instrument to which such Party is a party or by which such Party or any of its properties or assets are bound or that is otherwise applicable to such Party; or
 - (v) create or impose any liens, mortgages, pledges, claims, security interests, charges or Encumbrances or obligations to create a lien, charge, pledge, security interest, encumbrances or mortgage in or on the property of such Party, except for encumbrances that would not, individually or in the aggregate, have a material adverse effect on the financial condition or Prospects or business of such Party so as to prevent such Party from fulfilling its obligations under this MOU;
- (b) This MOU is the legal and binding obligation of such Party, enforceable in accordance with its terms against it; and there is no litigation pending or, to the best of such Party's knowledge, threatened to which it or any of its Affiliates is a party that presently affects or which would have a material adverse effect on the financial condition or prospects or business of such Party in the fulfilment of its obligations under this MOU.

8. Termination

This MOU shall be effective from the date hereof and shall continue in full force and effect until the completion of the work in accordance with the Contract MOU, in case the Project is awarded to the Consortium. However, in case the Consortium is either not pre-qualified for the Project or does not get selected for award of the Project, the MOU will stand terminated in case the Applicant is not pre-qualified or upon return of the Bid Security by the Authority to the Bidder, as the case may be.

9. Miscellaneous

9.1 This Joint Bidding MOU shall be governed by laws of {India}.

9.2 The Parties acknowledge and accept that this MOU shall not be amended by the Parties without the prior written consent of the Authority.

IN WITNESS WHEREOF THE PARTIES ABOVE NAMED HAVE EXECUTED AND DELIVERED THIS MOU AS OF THE DATE FIRST ABOVE WRITTEN.

SIGNED, SEALED AND DELIVERED
For and on behalf of
LEAD MEMBER by: SECOND PART

SIGNED, SEALED AND DELIVERED

(Signature)

(Name)

(Designation)

(Address)

(Signature)

(Name)

(Designation)

(Address)

SIGNED, SEALED AND DELIVERED SIGNED, SEALED AND DELIVERED

For and on behalf of
THIRD PART

For and on behalf of
FOURTH PART

(Signature)

(Name)

(Designation)

(Address)

(Signature)

(Name)

(Designation)

(Address)

In the presence of:

1.

2.

Notes:

I. The mode of the execution of the Joint Bidding MOU should be in accordance with the procedure, if any, lay down by the Applicable Law and the charter documents or the executant(s) and when it is so required, the same should be under common seal affixed in accordance with the required procedure.

2. Each Joint Bidding MOU should attach a copy of the extract of the charter documents and documents such as resolution / power of attorney in favour of the person executing this MOU for the delegation of power and authority to execute this MOU on behalf of the Consortium Member.

3. For a Joint Bidding MOU executed and issued overseas, the document shall be legalized by the Indian Embassy and notarized in the jurisdiction where the Power of Attorney has been executed.

ANNEXURE-K

Format for Power of Attorney for Lead Member of Consortium

Whereas the Faridabad Smart City Limited (FSCL) ("the Authority") has invited bids from interested parties for the (Name of the Project *****). ("the Project").Whereas, and..... (collectively the " Consortium") being Members of the Consortium are interested in bidding for the Project in accordance with the terms and conditions of the BID and other connected documents in respect of the Project, and

Whereas, it is necessary for the Members of the Consortium to designate one of them as the Lead Member with all necessary power and authority to do for and on behalf of the Consortium, all acts, deeds and things as may be necessary in connection with the Consortium's bid for the Project and its execution.

NOW THEREFORE KNOW ALL MEN BY THESE PRESENTS

We,..... Having our registered office at M/s....., having our registered office at, and M/s...., having our registered office at, (hereinafter collectively referred to as the "Principals") do hereby irrevocably designate, nominate, constitute, appoint and authorize M/s., having its registered office at....., being one of the Members of the Consortium as the Lead Member and true and lawful attorney of the Consortium (hereinafter referred to as the "Attorney") and hereby irrevocably authorize the Attorney (with power to sub-delegate) to conduct all business for and on behalf of the Consortium and any one of us during the bidding process and in the event the Consortium is awarded the Concession/ Contract, during the execution of the Project, and in this regard, to do on our behalf and on behalf of the Consortium, all or any or such acts, deeds or things as are necessary or required or incidental to the submission of its bid for the Project, including but not limited to signing and submission of all applications, bids and other documents and writings, accept the Letter of Award. participate in bidders' and other conferences, respond to queries, submit information/ documents, sign and execute contracts and undertakings consequent to acceptance of the bid of the Consortium and generally to represent the Consortium in all its dealings with the Authority, and/ or any other Government Agency or any person, in all matters in connection with or relating to or arising out of the Consortium's bid for the Project and/ or upon award thereof till the Concession MOU is entered into with the Authority.

And hereby agree to ratify and confirm and do hereby ratify and confirm all acts, deeds and things done or caused to be done by our said Attorney pursuant to and in exercise of the powers conferred by this Power of Attorney and that all acts, deeds and things done by our said Attorney in exercise of the powers hereby conferred shall and shall always be deemed to have been done by us/ Consortium.

IN WITNESS WHEREOF WE THE PRINCIPALS ABOVE NAMED HAVE EXECUTED THIS POWER OF ATTORNEY ON THIS..... DAY OF 20.....

For.....

(Signature, Name & Title)

For.....

(Signature, Name & Title)

For.....

(Signature, Name & Title)

Witnesses:

I.

2.

(Executants)

(To be executed by all the Members of the Consortium)

Notes:

- *The mode of execution of the Power of Attorney should be in accordance with the procedure, (any, laid down by the applicable law and the charter documents of the executant(S) and when it is so required, the same should be under common seal affixed in accordance with the required procedure.*
- *Wherever required, the Bidder should submit for verification the extract of the charter documents and documents such as a resolution/ power of attorney in favor of the person executing this Power of Attorney for the delegation of power hereunder on behalf of the Bidder.*

For a Power of Attorney executed and issued overseas, the document will also have to be legalized by the Indian Embassy and notarized in the jurisdiction where the Power of Attorney is being issued. However, the Power of Attorney provided by Bidders from countries that have signed the Hague Legislation Convention, 1961 are not required to be legalized by the Indian Embassy (it carries a conforming Appostille certificate.

ANNEXURE - L
FORMAT FOR LETTER OF ACCEPTANCE

From

Chief Executive Officer,
Faridabad Smart City Limited
Faridabad.

To

(Name & Address of Contractor)

-----,

Memo No. -----

Dated: -----

Subject: *(Name of Work)*- **Letter of Acceptance.**

Reference: *Tender No. & Date.*

This is to notify you that in accordance to RFP Clause No. 25.1, your Bid dated.....for (Name of Work) @Rs. ----- (*In Words -----Only*)(The above rate is inclusive of GST) is hereby accepted by CEO, FSCL. You are requested to sign a copy of the acceptance letter and forward to us.

You are hereby requested to furnish Performance Security, in the form and period detailed in terms of Clause 1 of GCC for an amount equivalent to (*Rs. In Figure-----*) within seven days of the receipt of this letter of acceptance and sign the agreement in accordance with clause 27.3 of ITB , failing which action as stated in clause 13.5 of ITB will be taken.

The tender has been accepted subject to the Scope of services and terms & conditions indicated in the RFP.

Deputy General Manager
For: Chief Executive Officer,
Faridabad Smart City Limited

Copy to:-
All concerns

ANNEXURE - M **FORMAT FOR AGREEMENT**

This agreement entered into on this the ____ day of _____, 2018 at Faridabad between Faridabad Smart City Limited (FSCL) a Special Purpose Vehicle which was incorporated on Twentieth day of September Two Thousand sixteen under the Companies Act, 2013 and represented by its Board of Directors (hereinafter referred to as “the Employer” which expression shall mean and include, wherever the context so requires or admits, its assigns, nominees, successors-in-interest and administrators)

And:

(Name of the Bidder) having its registered office *(Address of Bidder)* represented here in by its Authorised Signatory *(Name and Address)* (hereinafter referred to as “the Contractor”, which expression shall mean and include, wherever the context so requires or admits, its successors-in-interest, administrators and executors)

WHEREAS the Employer is desirous that the Contractor execute works “Construction of Smart Park with operation and maintenance of 5 years including with a Defect Liability Period of Two Years” as specified in the Contract Document /RFP(hereinafter called “the Works”) at a cost of INR *(In words.....Only)* (Rs. *In Figure*). The rates quoted by the Contractor shall be deemed to be inclusive of the GST and other levies, royalty, Labour Cess, Toll Tax, if any, that the Contractor will have to pay for the performance of the Contract, together with all general risks, liabilities and obligations set out or implied in the Contract. The duration of the work will be *(Duration)* months including rainy season from the date of issue of work order or date stipulated in the work order.

NOW THIS AGREEMENT WITNESSTH as follows:

- 1 In this Agreement, words and expression shall have the same meaning as are respectively assigned to them in the conditions of contract including all the documents which shall be deemed to form and be ready and construed as part of this Contract Agreement hereinafter referred to.
- 2 In consideration of the payments to be made by the Employer to the Contractor as hereinafter mentioned, the Contractor hereby covenants with the Employer to execute and complete the Works and remedy any defects therein conformity in all aspects with the provisions of the contract.
- 3 The Employer hereby covenants to pay the Contractor in consideration of the execution and completion of the Works and remedying the defects wherein Contract Price or such other sum as may become payable under the provisions of the Contract at the times and in the manner prescribed by the Contract.
- 4 The Contractor shall perform all the works specified in the Contract Document/ Tender within the stipulated time period and shall ensure the compliance of labour legislation, environment laws and all other applicable laws.

- 5 The following documents shall be deemed to form and be ready and construed as part of this Contract Agreement viz.
 - i) Letter of Acceptance
 - ii) Contractor/s Bid as quoted
 - iii) RFP documents including conditions of contract (General and Special), Drawing and Specifications , Bill of Quantities, all corrigendum and pre-bid responses, etc. and
 - iv) Any other document listed in the RFP.
 - v) All the correspondence exchanged, if any between the Employer and the Contractor after receipt of bids till signing of agreement.

- 6 The bidder shall indemnify the FSCL and its Project Management Consultant staff on all accounts from all aspects while performing the scope of services of this project.

- 7 Any amendment and/or modifications to this agreement shall be valid and binding on either party, only if such amendment/modification is mutually agreed to in writing and executed by both parties.

- 8 If any provision contained herein should be held unlawful, becomes incapable of performance by either party, is rendered void or unenforceable for any reason, that provision shall be severed from this agreement and the other provisions shall continue to be valid and performed, as if the severed provision was never a part of this agreement.

- 9 If any provision is not contained herein or in tender document specifically, the same shall be dealt with in accordance with the decision of the Employer and binding on either party.

10 NOTICES

All notices required to be given under this agreement shall be deemed to be sufficiently given if they are forwarded by registered post A.D./hand delivery with acknowledgment to:

The Chief Executive Officer,
Faridabad Smart City Limited
 Nain Sadan, 3rd Floor, Plot No. 35
 Sector 20 A, Behind EF3 Mall
 Near Old Faridabad Metro Station
 Faridabad – 121 001
 Haryana.
Email : faridabadsmartcitylimited@gmail.com

The Contractor at:

Name and Address of contractor

- 11 This agreement shall be constructed and interpreted in accordance with the laws of India. The courts at Faridabad alone, to the exclusion of all other courts elsewhere in India, shall have jurisdiction to try any dispute arising out of this Agreement.

THE ORIGINAL OF THIS AGREEMENT SHALL BE WITH THE Employer AND THE SIGNED

DUPLICATE OR XEROX COPY OF THE AGREEMENT SHALL BE HANDED OVER TO THE CONTRACTOR.

In witness where of the parties hereto have here unto set their hands the day year first above written.

Signature

Deputy General Manager
For Chief Executive Officer,
Faridabad Smart City Limited

Signed and delivered by the CEO FSCL by the hands of (Name of the signatory), and Constituted attorney in the presence of

1.

2.

Signature
Authorised
Signatory(*Name*)

For M/s (Name of Contractor)

Signed and delivered by the hands of (Name), Authorised Signatory of (M/s Name of Contractor) in the presence of

1.

2.

ANNEXURE - N

Issue of Notice to proceed with the work

Date : -----

To,

Dear Sir,

Pursuant to your furnishing the requisite performance security of **(Rs. In Figure)** and signing of the contract agreement for the work of “*(Name of Work-----)*” at a contract price of Rs. -----/- *(In Words -----Only)* inclusive of GST.

You are hereby instructed to proceed with the execution of the said works in accordance with the contract documents.

The time allowed for carrying out the work is *(Duration)* months, including Rainy Season, to be reckoned from the date of written orders to commence the work as stipulated in clause 27.3 of ITB

Yours faithfully

Deputy General Manager
For Chief Executive Officer,
Faridabad Smart City Limited

ANNEXURE - O

BID SECURITY - EMD (BANK GUARANTEE)

WHEREAS, _____ [NAME OF BIDDER] (hereinafter called “the Bidder”) has submitted his Bid dated _____ [date] for the work of _____ [name of Contract hereinafter called “the Bid”].

KNOW ALL PEOPLE by these presents that We

[name of Bank] of _____ [name of country] having our registered office at _____ [name of Employer] (hereinafter called “the Employer”) in the sum of _____ * for which payment well and truly to be made to the said employer the Bank itself, his successors and assigns by these presents.

SEALED with the common seal of the said Bank this _____ day of _____, 2018 THE CONDITIONS of this obligation are;

If after Bid opening the Bidder withdraws his bid during the period of Bid validity specified in the Form of Bid .

OR

If the Bidder having been notified to the acceptance of his bid by the Employer during the period of Bid validity:

fails or refuses to execute the form of Agreement in accordance with the Instructions to Bidders, if required; or

fails or refuses to furnish the Performance Security, in accordance with the Instructions to Bidders; or

does not accept the correction of the Bid Price pursuant to Clause 23.

We undertake to pay to the Employer up to the above amount upon receipt of his first written

demand, without the Employer having to substantiate his demand, provided that in his demand the Employer will note that the amount claimed by him is due to him owing to the occurrence of one or any of the three conditions, specifying the occurred condition or conditions.

This Guarantee will remain in force up to and including the date _____ ** days after the deadline for submission of Bids or such deadline is stated in the Instructions to Bidders or as it may be extended by the Employer, notice of which extension(s) to the Bank hereby waived. Any demand in respect of this guarantee should reach the Bank not later than the above date.

DATE _____ SIGNATURE _____

WITNESS _____ SEAL _____

[Signature, name and address]

The Bidder should insert the amount of the guarantee in words and figures denominated in Indian Rupees. This figure should be the same as shown in Clause 13.1 of the Instructions to Bidders.

45 days after the end of the validity period of the Bid. Date should be inserted by the employer before the Bidding documents are issued.

Signaturer of Tenderer

PART B: Annexure 1 to 9

Annexure 1

Qualification Information:-					
1.1 (A)	Constitution or legal status of Bidder [attach copy]				
(B)	Place of registration of Firm/ Company (in case of other than individuals)				
(C)	Principal place of business:				
(D)	Name of Power of attorney holder for Signing of the Bid. (bidder)[attach copy]				
1.2	Total annual volume of civil engineering construction work executed and Payments received each year in the immediate five years preceding the year in which tenders are invited. (Attach certificate from Chartered Accountant)- indexed @ 10% (ten per cent) compounded per year	Financial Year	(Rs. in crores)		
			Turnover in the year	Add for indexing	Total

- Proprietary firm. Partnership firm with the certificate of registration by registrar of firms & article and Memorandum of Association with Certificate of Incorporation.
- Mention and highlight the year, which the Bidder considers for evaluation by the committee.

Signature:

Bidder's Seal

ANNEXURE-2
BANKERS CERTIFICATE

This is to certify that M/s. _____ is a reputed company with a good financial standing. If the contract for this work, namely _____ (Name of the work) is awarded to the above firm, we shall be able to provide Over Draft/ Credit Facilities to the extent of Rs.----- to meet the working capital requirements for executing the above contract.

Sd/- Senior Bank Manager, Name of the Bank, Address:

.....

Note: The original letter of credit shall be submitted in Envelope 'B' to the Employer without fail.

The solvency certificate should not be more than twelve months old. The solvency certificate shall be on Banks Letter Head (original) and duly signed by the Banks Designated Authority in Original. The solvency Certificate shall be as per the prescribed format.

ANNEXURE 3

INFORMATION ON EXECUTION OF SIMILAR WORKS [REFER QUALIFICATION CRITERIA, S.NO.1]									
S. No.	Name of Project	Name of Employer	Value of contract	Contract No.	Date of Issue of Work Order	Stipulated Date of Completion	Actual Date of Completion	Value of work done	Remarks
1	2	3	4	5	6	7	8	9	10

Note:

1. Attach relevant certificates from the Engineer in charge, not below the rank of Executive Engineer or equivalent.
2. Bidder may attach certified copies of work order(s) and completion certificate issued by the Engineer in Charge not below the rank of an Executive Engineer.
3. The Supporting documents (completion certificate etc) shall clearly indicate the value of work completed.

Signature:

Bidder's Seal

ANNEXURE-4

Work performed on all classes of Civil Engineering Construction Works over the last five years

S No	Name of Project	Name of Employer	Description of work	Value of contract (Rs.in Lacs)	Contract No.	Date of Issue of Work Order	Stipulated Date of Completion	Actual Date of Completion	Year wise value of work done as per certificate from the employer (Rs. In Lacs)					Remarks explaining reasons for Delay, if any; and the amount of deductions due to delay Also mention if any claim or dispute is pending in any forum.
									10	11	12	13	14	
1	2	3	4	5	6	7	8	9	10	11	12	13	14	15

Note: (i) Attach relevant certificates from the Engineer in charge, not below the rank of Executive Engineer or equivalent.

(ii) Bidder may attach certified copies of work order(s) and completion certificate(s) issued by Engineer in charge not below the rank of Executive Engineer

(iii) certificate etc) shall clearly indicate the value of work completed.

The Supporting documents (completion

Signature :

Bidder's seal :

ANNEXURE-5

Existing commitments and ongoing works in all classes of construction works

S. No.	Name of Project	Description of work	Contract No &Year	Name & address of the employer	Value of contract	Date of Issue of Work Order	Stipulated Date of Completion	Stipulated period of completion in months	Anticipate d date of completion	Value of work done up to the date of issue of this N.I.T	Probable value of works balance to be completed	Anticipate d months required for completion of balance works	Value of claims or dispute if any, pending
1	2	3	4	5	6	7	8	9	10	11	12	13	14

Note: The Supporting documents (completion certificate etc) shall clearly indicate the value of work completed.

ANNEXURE-6

Information regarding current claims, arbitration, litigation the Bidder is involved in.

S. No.	Name of Other party(s)	Agreement No. Date year and Dept.	Brief of cause of claims, arbitration /dispute (give reference of contract details)	Where Litigation is pending (in the department /Court/arbitration) (mention Dept./Court/Arbitration)	Amount involved/ claimed

Can use separate sheets for each agreements if necessary.

ANNEXURE-7

Affidavit

I,.....S/o.....Aged...
.....years.....(Address.....
.....)
.....)

(For and on behalf of),
do here by and herewith solemnly affirm / state on oath that: -

- 1. All documents and Information's furnished are correct in all respects to the best of my knowledge and belief**

- 2. I/We have not suppressed or omitted any required/relevant information.**

- 3. I/We is neither associated, nor has been associated, directly or indirectly, with the Consultant or any other entity that has prepared the design, specifications, and other documents for the Project or being proposed as Project Manager for the Contract.**

- 4. I/We hereby authorize the Faridabad Smart City Limited, Faridabad Officials to get all the documents submitted verified from appropriate source(s).**

(.....)

Authorized signatory / for and on behalf of

.....

(Affix seal)

ANNEXURE-8

List of key and minimum plant & Equipment to be deployed on Contract Work (Electrical/Infrastructure works/Road)

S. No.	Type of Equipment	Minimum required	Available	Own/ Lease
1	Truck/Tipper	8		
2	Excavator/loader	3		
3	Earth compactors	1		
4	Vibratory Roller	1		
5	Grader	1		
6	Concrete Paver finisher	1		
7	Vehicle mounted Bitumen Sprayer	1		
8	Bitumen Paver finisher	1		
9	Pneumatic tyre Roller	1		
10	Kerb casting machine	1		
11	Thermoplastic painting equipment	1		
12	Modern Survey equipment	1		
13	Concrete Mixer with integral weighing batching facility	1		
14	Generators 100KVA	1 Sets		
15	Plate compactors	3		
16	Water Pumps more than 2 H.P.	2		
17	Bar Bending Machines	2		
18.	Bar Cutting machine	2		
19.	Welding Sets	2		
20.	Prefabricated shuttering capacity	500 sq.m/day		
21	Crain/Lifter	1		
22	Concrete Batching Plant	1		
23	Transit Mixer (TM)	6		
24	Water Tanker with Sprayer	2		
25	Other equipment as required			

Note: - The list of the equipment and plants as mentioned above are tentative. Engineer In-charge of the project can modify the above list of the plant and equipment as per their requirements. . It is Preferred tht the bidder submit the List of Electrical T & P also.

ANNEXURE-9

List of Technical person to be deployed on Contract work

S. No.	Personnel	Qualification	Min. Personnel required.
1	Project Manager	BE Civil +15 Years' experience in Civil Construction works	1
2	Construction Managers	BE Civil +10 Years' experience in Civil Construction works	1
3	Sr. Project Engineer (Highway & Structure)	B.E. Civil + 8 Years' Experience in Civil Works.	1
4	Project Engineer (QA & QC)	B.E. Civil + 5 Years' Experience in Civil Works.	1
5	Project Engineer (Utility)	B.E. Civil + 5 Years' Experience in Relevant Field.	1
6	Site Engineer	Diploma in Civil Engineering + 05 Years' Experience in Civil Works.	2
7	Sr. Electrical Engineer	B.E. Electrical + 15 Years' Experience in Electrical Works	1
8	Electrical Engineer	Diploma in Electrical Engineering + 05 Years' Experience in Electrical Works.	2
9	Wire Man	ITI, Electrical 02 Years' Experience in Electrical Works	4
10	Horticulturist	BSc. Horticulture 05 Years' Experience in Horticulture Works	1
11	Mali	05 Years' Experience in Horticulture Works	6

Note: - The list of the Technical persons as mentioned above is tentative. Engineer In-charge of the project can modify the above list of the Technical persons as per their requirements.

SECTION 9: PRE CONTRACT INTEGRITY PACT

(To be submitted on Rs 100 Stamp Paper)

1. GENERAL

1.1. This pre-bid contract agreement (herein after called the Integrity Pact) is made onday of the monthbetween the Faridabad Smart City Limited (FSCL) acting through Shri/Smt..... (Designation of the FSCL officer)(Hereinafter called the “BUYER” which expression shall mean and include, unless the context otherwise requires, his successors in the office and assigns) and the First Party, proposes to procure..... (Name of the Store/Equipment/ Work/ Service) and M/s.represented by Shri (herein after called the BIDDER/Seller, which expression shall mean and include, unless the context otherwise requires, his successors an permitted assigns) and the Second Party, is willing to offer/ has offered.

1.2. WHEREAS the BIDDER is a Private Company/ Public Company/ Government Undertaking/ Partnership/ Registered Export Agency, constituted in accordance with the relevant law in the matter and the BUYER, performing its function as SPV under provision of Companies Act 2013.

2. OBJECTIVES:

NOW, THEREFORE, the BUYER and the BIDDER agree to enter into this pre-contract agreement, hereinafter referred to as Integrity Pact to avoid all forms of corruption by following a system that is fair, transparent and free from any influence/ prejudiced dealings prior to ,during and subsequent to the Contract to be entered into which a view to:-

2.1. Enabling the BUYER to obtain the desired Stores/ Equipment/Work/Service at a competitive price in conformity with the defined specifications by avoiding the high cost and the distortionary impact of corruption on public procurement, and

2.2. Enabling BIDDER to abstain from bribing or indulging in any corrupt practices in order to secure the contract by providing assurance to them that their competitors will also abstain from bribing any corrupt practices and the BUYER will commit to prevent corruption, in any form, by its official by following transparent procedures.

3. COMMITMENTS OF THE BUYER

The BUYER commits itself to the following:-

3.1. The BUYER undertakes that no official of the BUYER connected directly or indirectly with the contract, will demand, take promise for or accept, directly or through intermediaries, any bribe, consideration, gift, reward, favour or any material or immaterial benefits or any other advantage from the BIDDER, either for themselves or for any person, organization or third party related to the contract in exchange for an advantage in the bidding process, bid evaluation , contracting or implementation process related to the contract.

3.2. The BUYER will, during the pre-contract stage, treat BIDDERS alike, and will provide to all BIDDERS the same information and will not provide any such information to any particular BIDDER which could afford an advantage to that particular BIDDER in comparison to the other BIDDERS

3.3. All the officials of the BUYER will report the appropriate Government office any attempted or completed breaches of the above commitments as well as any substantial suspicion of such a breach.

3.4. In case any such preceding misconduct on the part of such official(s) is reported by the BIDDER to the BUYER with the full and verifiable facts and the same *prima facie* found to be correct by the

BUYER, necessary disciplinary proceedings, or any other action as deemed fit, including criminal proceedings may be initiated by the BUYER and such a person shall be debarred from further dealings related to the contract process. In such a case while an enquiry is being conducted by the BUYER the proceedings under the contract would not be stalled.

4. COMMITMENTS OF BIDDERS

The BIDDER commits itself to take all measures necessary to prevent corrupt practices, unfair means and illegal activities during any stage of its bid or during any pre-contract or post-contract stage in order to secure the contract or in furtherance to secure it and in particular commit itself to the following:-

4.1. The BIDDER will not offer, directly or through intermediaries, any bribe, gift, consideration, reward, favour, any material or immaterial benefit or other advantage, commission, fees, brokerage or inducement to any official of the BUYER, connected directly or indirectly with the bidding process, or to any person, organization or third party related to the contract in exchange for any advantage in the bidding, evaluation, contracting and implementation of the contract.

4.2. The BIDDER further undertakes that it has not been given, offered or promised to give, directly or indirectly any bribe, gift, consideration, reward, favour, any material or immaterial benefit or other advantage, commission, fees, brokerage, or inducement to any official of the BUYER or otherwise in procuring the Contract or forbearing to do or having done any act in relation to the obtaining or execution of the contract or any other contract with the Government for showing or forbearing to show favour or disfavour to any person in relation to the contract or any other contract with the Government.

4.3. The BIDDER further confirms and declares to the BUYER that the BIDDER is the original Manufacturer/Integrator/Authorized government sponsored export entity of the stores and has not engaged in individual or firm or company whether Indian or Foreign to intercede, facilitate or in any way to recommend to the BUYER or any of its functionaries, whether officially or unofficially to the award of the contract to the BIDDER, nor has any amount been paid, promised or intended to be paid to any such individual, firm or company in respect of any such intercession, facilitation or recommendation.

4.4. The BIDDER, either while presenting the bid or during pre-contract negotiations or before signing the contract, shall disclose any payment he has made, is committed to or intends to make to officials of the BUYER or their family members, agents, brokers or any other intermediaries in connection with the contract and the details of services agreed upon for such payments.

4.5. The BIDDER will not collude with other parties interested in the contract to impair the transparency, fairness and progress of the bidding process, bid evaluation contracting and implementation of the contract.

4.6. The BIDDER will not accept any advantage in exchange for any corrupt practice, unfair means and illegal activities.

4.7. The BIDDER shall not use improperly, for purpose of competition or personal gain, or pass on to others, any information provided by the BUYER as part of the business relationship, regarding plans, technical proposal and business details, including information contained in any electronic data carrier. The BIDDER also undertakes to exercise due and adequate care lest any such information is divulged.

4.8. The BIDDER commits to refrain from giving any complaint directly or through any other manner without supporting it with full and verifiable facts.

4.9. The BIDDER shall not instigate or cause to instigate any third person to commit any of the acts mentioned above.

5. PREVIOUS TRANSGRESSION

5.1. The BIDDER declares that no previous transgression occurred in the last three years immediately before signing this Integrity Pact with any other company in any country in respect of any corrupt practices envisaged hereunder or with any Public Sector Enterprise in India or any Government Department in India that could justify Bidder's exclusion from the tender process.

5.2. If the BIDDER makes incorrect statement on this subject, BIDDER can be disqualified from the tender process or the contract, if already awarded, can be terminated for such reasons.

6. EARNEST MONEY (SECURITY DEPOSIT)

6.1. Every BIDDER while submitting commercial bid, shall deposit an amount as specified in RFP as Earnest Money/ Security Deposit, with the BUYER through any of the following instruments:

6.1.1. Bank Draft or Pay Order in favour of

6.1.2. A Confirmed guarantee by an Indian Nationalized Bank, promising payment of the guaranteed sum to theon demand within three working days without any demur whatsoever and without seeking any reasons whatsoever. The demand for payment by the BUYER shall be treated as conclusive proof of payment.

6.1.3. Any other mode or through any other instrument (to be specified in the RFP).

6.2. The Earnest Money/ Security Deposit shall be valid up to a period of five years or the complete conclusion of the contractual obligations to the complete satisfaction of both the BIDDER and BUYER, including warranty period, whichever is later.

6.3. In the case of successful BIDDER a clause would also be incorporated in the Article pertaining to Performance Bond in the Purchase Contract that the provisions of Sanctions for violation shall be applicable for forfeiture of Performance Bond in case of a decision by the BUYER to forfeit the same without assigning any reason for imposing sanction for violation of this Pact.

6.4. No interest shall be payable by the BUYER to the BIDDER on Earnest Money/ Security Deposit for the period of its currency.

7. SANCTIONS FOR violations'

7.1. Any breach of the aforesaid provisions by the Bidder or any one employed by it or acting on its behalf (whether with or without the knowledge of the BIDDER) shall entitle the BUYER to take all or any one of the following actions, wherever required:-

7.1.1. To immediately call off the pre contract negotiations without assigning any reason or giving any compensation to the BIDDER. However, the proceedings with the other BIDDER(S) would continue.

7.1.2. To forfeit fully or partially the Earnest Money Deposit (in pre-contract stage) and/ or Security Deposit/ Performance Bond (after the contract is signed), as decided by the BUYER and the BUYER shall not be required to assign any reason therefore.

7.1.3. To immediately cancel the contract, if already signed, without giving any compensation to the BIDDER.

7.1.4. To recover all sums already paid by the BUYER, and in case of the Indian BIDDER with interest thereon at 2% higher than the prevailing Prime Lending Rate while in case of a BIDDER from a country other than India with interest there on at 2 % higher than the LIBOR. If any outstanding payment is due to the BIDDER from the BUYER in connection with any other contract such outstanding payment could also be utilized to recover the aforesaid sum and interest.

7.1.5. To encash the advance bank guarantee and performance bond/ warranty bond, if furnished by the BIDDER, in order to recover the payments already made by the BUYER, along with interest.

7.1.6. To cancel all or any other contracts with the BIDDER and the BIDDER all be liable to pay compensation for any loss or damage to the BUYER resulting from such cancellation/rescission and the BUYER shall be entitled to deduct the amount so payable from the money(s) due to the BIDDER.

7.1.7. To debar the BIDDER from part on behalf of the participating in future bidding processes of the Government of Haryana for a minimum period of five years, which may be further extended at the discretion of the BUYER.

7.1.8. To recover all sums paid in violation of this Pact by BIDDER(S) to any middlemen or agent or broken with a view to securing the contract.

7.1.9. In cases where irrevocable Letters of Credit have been received in respect of any contract signed by the BIDDER, the same shall not be opened.

7.1.10. If the BIDDER or any employee of the BIDDER or any person acting on behalf of the BIDDER, either directly or indirectly is closely related to any of the officers of the BUYER or alternatively, if any close relative of an officer of the BUYER has financial interest/stake in the BIDDER'S firm, the same shall be disclosed by the BIDDER at the time of filling of tender. Any failure to disclose the interest involved shall entitle the BUYER to rescind the contract without payment of any compensation to the BIDDER.

The term 'close relative' for this purpose would mean spouse whether residing with the Government servant or not, but include a spouse separated from the Government servant by a decree or order of a competent court: son or daughter or custody the step son or step daughter and wholly dependent upon Government servant, but does not include a child or step child who is no longer in any way dependent upon the Government servant or of whose the Government servant has been deprived of by or under any law; any other person related, whether by blood or marriage, to the Government servant or to the Government servant's wife or husband and wholly dependent upon Government servant.

7.1.11. The BIDDER shall not lend to or borrow any money from or enter into any monetary dealings or transactions, directly or indirectly, with any employee of the BUYER, and if he does so, the BUYER shall be entitled forthwith to rescind the contract and all other contracts with the BIDDER. The BIDDER shall be liable to pay compensation for any loss or damage to the BUYER resulting from such rescission and the BUYER shall be entitled to deduct the amount so payable from the money(s) due to the BIDDER.

7.2. The decision of the BUYER to the effect that a breach of the provisions of this pact has been committed by the BIDDER shall be final and conclusive on the BIDDER. However, the BIDDER can approach the Monitor(s) appointed for the purpose of this Pact.

8. FALL CLAUSE

8.1. The BIDDER undertakes that it has not supplied/is not supplying similar product/ systems or subsystems at a price lower than that offered in the present bid in respect of any other Department of the Government of Haryana or PSU and if it is found at any stage that similar product/ systems or sub systems was supplied by the BIDDER TO any other Department of the Government of Haryana or PSU at a lower price, then that very price, with due allowance for elapsed time, will be applicable to the present case and the difference in the cost would be refunded by the BIDDER to the BUYER, if the contract has already been concluded.

9. INDEPENDENT MONITORS

9.1. The BUYER will appoint Independent Monitors (hereinafter referred to as Monitors) for this Pact.

9.2. The task of the Monitors shall be to review independently and objectively, whether and to what extent the parties comply with the obligations under this Pact.

9.3. The Monitors shall not be subject to instructions by the representatives of the parties and perform their functions neutrally and independently.

9.4. Both the parties accept that the Monitors have the right to access all the documents relating to the project/ procurement, including minutes of meetings. The Monitor shall be under contractual obligation to treat the information and documents of the BIDDER/Sub Bidder(s) with confidentiality.

9.5. As soon as the Monitor notices, or has reason to believe, a violation of this Pact, he will so inform the Authority designated by the BUYER.

9.6. The Monitor will submit a written report to the designated Authority of BUYER/ Secretary in the Department/ within 8 to 10 weeks from the date of reference or intimation to him by the BUYER/BIDDER and, should the occasion arise, submit proposals for correcting problematic situations.

10. FACILITATION OF INVESTIGATION

In case of any allegation of violation of any provisions of this Pact or payment of commission, the BUYER or its agencies shall be entitled to examine all the documents including the Books of Accounts of the BIDDER and the BIDDER shall provide necessary information of the relevant documents and shall extend all possible help for the purpose of such examination.

11. LAW AND PLACE OF JURISDICTION

This Pact is subject to Indian Law, the place of performance and jurisdiction shall be the seat of the BUYER.

12. OTHER LEGAL ACTIONS:

The actions stipulated in this Integrity Pact are without prejudice to any other legal action that may follow in accordance with the provisions of the any other law in force relating to any civil or criminal proceedings.

13. VALIDITY

13.1. The validity of this Integrity Pact shall from the date of its signing and extend up to 5 years or the complete execution of the contract to the satisfaction of both the BUYER and the BIDDER/Seller whichever is later. In case BIDDER is unsuccessful, this Integrity Pact shall expire after six months from the date of the signing of the contract.

13.2. If one or several provisions of this Pact turn out to be invalid; the remainder of this pact shall remain valid. In such case, the parties will strive to come to an agreement to their original intentions.

14. The parties hereby sign this Integrity Pact aton

BUYER

BIDDER