

# ALIGARH SMART CITY LIMITED

www.smartcityaligarh.com

1. Chief Executive Office, Aligarh Smart City Limited, Aligarh invites online Bids on two stage system for the following works:

NIT Reference No.	Name of Project/ Work(s)	Estimate Amount (Rs.)	Bid Security (Earnest Money) (Rs.)	Cost of Document/ Tender Fee (Rs.)	Period of Completion
Tender No: 11/ASCL/ 2018-19	Design, Manufacture, Supply, Installation and Commissioning of Different Capacity Roof Top Solar PV Power Projects under Net Metering Policy in Aligarh City (Smart City Mission)	6,11,94,000/- (Six Crores Eleven Lakhs Ninety Four Thousand Only)	INR 12,23,880/- (Twelve Lakhs Twenty Three Thousand Eight Hundred and Eighty Only)	Rs. 5000/- (Rupees Five Thousand)	Six (06) Months

2. Important data of RFB is as mentioned below :

Name of Project/Work(s)	Availability of Tender on-line for bidding		Last Date & Time for on-line Submission of Bids	Date & Time of opening of tender	
	From	To		Technical Bid	Financial Bid
Design, Manufacture, Supply, Installation and Commissioning of Different Capacity Roof Top Solar PV Power Projects under Net Metering Policy in Aligarh City (Smart City Mission)	28-08-2018 1400 Hrs	12-09-2018 1700 Hrs	12-09-2018 1700 Hrs	14-09-2018 1500 Hrs	To be intimated later

3. A Pre-Bid meeting is as mentioned below :

Design, Manufacture, Supply, Installation and Commissioning of Different Capacity Roof Top Solar PV Power Projects under Net Metering Policy in Aligarh City (Smart City Mission)	Date: 05-09-2018 : Time : 1500 hrs., Place: <b>Aligarh Smart City Ltd. Office</b> , Room no.108, Nagar Nigam Aligarh, Sewa Bhawan, Civil Lines,Lal Dikki Road, Aligarh, Uttar Pradesh 202001, India
---	---

4. For additional details such as estimated cost, important data, detailed information, qualification and eligibility criteria, visit website <https://etender.up.nic.in>, <https://www.nnaligarh.com>, <https://smartcityaligarh.com> for downloading of RFB. 5. For participating in the above e-tender, the bidder shall have to get them registered with <https://etender.up.nic.in> and get user ID, password, Class 3, digital signatures Certificate (DSC) is mandatory to participate in the e-tendering process. For any clarification/difficulty/ regarding E-tendering process bidders can contact helpdesk on the phone numbers mentioned in the Website.6. The bidders should keep checking the website for any addenda/corrigenda and the bidder should incorporate the same in their bid documents. No addenda/corrigenda shall be published in the newspaper.

**Sd/- Chief Executive Officer,  
Aligarh Smart City Limited**



Specific Procurement Notice – Request for Bids (RFB)

**Project Name: Design, Manufacture, Supply, Installation and Commissioning of Different Capacity Roof Top Solar PV Power Projects under Net Metering Policy in Aligarh City- (Smart City Mission)**

---

## **Standard Procurement Document**

Section I - Instructions to Bidders .....	6
Section II - Bid Data Sheet (BDS).....	32
Section III - Evaluation and Qualification Criteria.....	37
Section IV - Bidding Forms.....	44
Section V - Eligible Countries .....	72
Section VI - Fraud and Corruption .....	73
Section VII - Works' Requirements .....	76
Section VIII - General Conditions of Contract.....	97
Section IX - Particular Conditions of Contract.....	125
Section X - Contract Forms .....	134

# **PART 1 – Bidding Procedures**

## Section I - Instructions to Bidders

### Contents

#### Table of Contents

<b>A. General.....</b>	<b>6</b>
1. Scope of Bid.....	6
2. Source of Funds .....	6
3. Fraud and Corruption.....	6
4. Eligible Bidders .....	6
5. Eligible Materials, Equipment and Services.....	8
<b>B. Contents of Bidding Document.....</b>	<b>8</b>
6. Sections of Bidding Document .....	8
7. Clarification of Bidding Document, Site Visit, Pre-Bid Meeting.....	9
8. Amendment of Bidding Document.....	10
<b>C. Preparation of Bids .....</b>	<b>11</b>
9. Cost of Bidding .....	11
10. Language of Bid.....	11
11. Documents Comprising the Bid.....	11
12. Letters of Bid and Schedules .....	12
13. Alternative Bids .....	12
14. Bid Prices and Discounts .....	13
15. Currencies of Bid and Payment .....	14
16. Documents Comprising the Technical Proposal.....	14
17. Documents Establishing the Eligibility and Qualifications of the Bidder.....	14
18. Period of Validity of Bids .....	14
19. Bid Security .....	15
20. Format and Signing of Bid.....	16
<b>D. Submission of Bids .....</b>	<b>17</b>
21. Sealing and Marking of Bids .....	17
22. Deadline for Submission of Bids .....	18
23. Late Bids .....	18
24. Withdrawal, Substitution, and Modification of Bids.....	18
<b>E. Public Opening of Technical Parts of Bids.....</b>	<b>19</b>
25. Public Opening of Technical Parts of Bids.....	19
<b>F. Evaluation of Bids – General Provisions .....</b>	<b>20</b>
26. Confidentiality .....	20
27. Clarification of Bids.....	20
28. Deviations, Reservations, and Omissions.....	21
29. Nonmaterial Nonconformities .....	21

<b>G. Evaluation of Technical Parts of Bids.....</b>	<b>21</b>
30. Evaluation of Technical Parts .....	22
31. Determination of Responsiveness.....	22
32. Qualification of the Bidder .....	22
33. Subcontractors .....	23
<b>H. Public Opening of Financial Parts.....</b>	<b>23</b>
34. Public Opening of Financial Parts .....	23
<b>I. Evaluation of Financial Parts.....</b>	<b>25</b>
35. Evaluation of Financial Parts .....	25
36. Correction of Arithmetical Errors.....	25
37. Conversion to Single Currency.....	26
38. Margin of Preference .....	26
39. Comparison of Financial Parts.....	26
40. Abnormally Low Bids .....	26
41. Unbalanced or Front Loaded Bids .....	27
42. Most Advantageous Bid.....	27
43. Employer’s Right to Accept Any Bid, and to Reject Any or All Bids.....	27
44. Standstill Period.....	28
45. Notice of Intention to Award.....	28
<b>J. Award of Contract .....</b>	<b>28</b>
46. Award Criteria .....	28
47. Notification of Award.....	28
48. Debriefing by the Employer .....	29
49. Signing of Contract.....	29
50. Performance Security.....	30
51. Adjudicator .....	30
52. Procurement Related Complaint.....	30

## Section I - Instructions to Bidders

<b>A. General</b>	
<b>1. Scope of Bid</b>	<p>1.1 In connection with the Specific Procurement Notice – Request for Bids (RFB), specified in the <b>Bid Data Sheet (BDS)</b>, the Employer, as <b>specified in the BDS</b>, issues this bidding document for the provision of Works as specified in Section VII, Works’ Requirements. The name, identification, of this RFB are <b>specified in the BDS</b>.</p>
	<p>1.2 Throughout this bidding document:</p> <ul style="list-style-type: none"> <li>(a) the term “in writing” means communicated in written form (e.g. by mail, e-mail, fax, including if <b>specified in the BDS</b>, distributed or received through electronic-procurement system used by the Employer) with proof of receipt;</li> <li>(b) if the context so requires, “singular” means “plural’ and vice versa; and</li> <li>(c) “Day” means calendar day, unless otherwise specified as a “Business Day.” A Business Day is any day that is a working day of the Employer. It excludes the Employer’s official public holidays.</li> </ul>
<b>2. Source of Funds</b>	<p>2.1 Source of Fund is from Smart City Mission funds ( Government of India and Government of Uttar Pradesh)</p>
<b>3. Fraud and Corruption</b>	<p>3.1 The Employer requires compliance with the Employer’s Anti-Corruption Guidelines and its prevailing sanctions policies and procedures as set forth in the GOI’s Sanctions Framework, as set forth in Section VI.</p> <p>3.2 In further pursuance of this policy, Bidders shall permit and shall cause their agents (where declared or not), subcontractors, sub-consultants, service providers, suppliers, and their personnel, to permit the Employer to inspect all accounts, records and other documents relating to any initial selection process, prequalification process, bid submission, proposal submission, and contract performance (in the case of award), and to have them audited by auditors appointed by the Employer.</p>
<b>4. Eligible Bidders</b>	<p>4.1 A Bidder may be a firm that is a private entity, or a state-owned enterprise or institution —subject to ITB 4—or any combination of them in the form of a joint venture (JV), under an existing agreement, or with the intent to enter into such an</p>

	<p>agreement supported by a letter of intent. In the case of a joint venture, all members shall be jointly and severally liable for the execution of the entire Contract in accordance with the Contract terms. The JV shall nominate a Representative who shall have the authority to conduct all business for and on behalf of any and all the members of the JV during the Bidding process and, in the event the JV is awarded the Contract, during contract execution. Unless <b>specified in the BDS</b>, there is no limit on the number of members in a JV.</p>
	<p>4.2 A Bidder shall not have a conflict of interest. All Bidders found to have a conflict of interest shall be disqualified. A Bidder may be considered to have a conflict of interest for the purpose of this Bidding process, if the Bidder:</p> <ul style="list-style-type: none"> <li>(a) directly or indirectly controls, is controlled by or is under common control with another Bidder; or</li> <li>(b) receives or has received any direct or indirect subsidy from another Bidder; or</li> <li>(c) has the same legal representative as another Bidder; or</li> <li>(d) has a relationship with another Bidder, directly or through common third parties, that puts it in a position to influence the Bid of another Bidder, or influence the decisions of the Employer regarding this Bidding process; or</li> <li>(e) or any of its affiliates participated as a consultant in the preparation of the design or technical specifications of the works that are the subject of the Bid; or</li> <li>(f) or any of its affiliates has been hired (or is proposed to be hired) by the Employer as Project Manager for the Contract implementation;</li> <li>(g) would be providing goods, works, or non-consulting services resulting from or directly related to consulting services for the preparation or implementation of the project <b>specified in the BDS 2.1</b> that it provided or were provided by any affiliate that directly or indirectly controls, is controlled by, or is under common control with that firm; or</li> <li>(h) has a close business or family relationship with a professional staff of the Employer (or of the project implementing agency, or of a recipient of a part of the loan) who: (i) are directly or indirectly involved in the preparation of the bidding document or specifications of the contract, and/or the Bid evaluation process of such</li> </ul>



	contract; or (ii) would be involved in the implementation or supervision of such contract unless the conflict stemming from such relationship has been resolved in a manner acceptable to the Employer throughout the procurement process and execution of the contract.
	4.3 A firm that is a Bidder (either individually or as a JV member) shall not participate in more than one Bid, except for permitted alternative Bids. This includes participation as a subcontractor in other Bids. Such participation shall result in the disqualification of all Bids in which the firm is involved. A firm that is not a Bidder or a JV member may participate as a subcontractor in more than one Bid.
	4.4 A Bidder may have the nationality of any country, subject to the restrictions pursuant to ITB 4. A Bidder shall be deemed to have the nationality of a country if the Bidder is constituted, incorporated or registered in and operates in conformity with the provisions of the laws of that country, as evidenced by its articles of incorporation (or equivalent documents of constitution or association) and its registration documents, as the case may be. This criterion also shall apply to the determination of the nationality of proposed subcontractors or sub-consultants for any part of the Contract including related Services.
	4.5 Bidders that are state-owned enterprises or institutions in the Employer’s Country may be eligible to compete and be awarded a Contract(s) only if they can establish, in a manner acceptable to the Employer, that they (i) are legally and financially autonomous (ii) operate under commercial law, and (iii) are not under supervision of the Employer unless approved by the Employer.
	4.6 A Bidder shall provide such documentary evidence of eligibility satisfactory to the Employer, as the Employer shall reasonably request.
<b>5. Eligible Materials, Equipment and Services</b>	5.1 The materials, equipment and services to be supplied under the Contract may have their origin in any country subject to the restrictions specified in Section V, Eligible Countries, and all expenditures under the Contract will not contravene such restrictions. At the Employer’s request, Bidders may be required to provide evidence of the origin of materials, equipment and services.
<b>B. Contents of Bidding Document</b>	
<b>6. Sections of</b>	6.1 The bidding document consist of Parts 1, 2, and 3, which include all the sections specified below, and which should be

<p><b>Bidding Document</b></p>	<p>read in conjunction with any Addenda issued in accordance with ITB 8.</p> <p><b>PART 1 Bidding Procedures</b></p> <ul style="list-style-type: none"> <li>• Section I - Instructions to Bidders (ITB)</li> <li>• Section II - Bid Data Sheet (BDS)</li> <li>• Section III - Evaluation and Qualification Criteria</li> <li>• Section IV - Bidding Forms</li> <li>• Section V - Eligible Countries</li> <li>• Section VI - Fraud and Corruption</li> </ul> <p><b>PART 2 Works' Requirements</b></p> <ul style="list-style-type: none"> <li>• Section VII – Works' Requirements</li> </ul> <p><b>PART 3 Conditions of Contract and Contract Forms</b></p> <ul style="list-style-type: none"> <li>• Section VIII - General Conditions of Contract</li> <li>• Section IX - Particular Conditions of Contract</li> <li>• Section X - Contract Forms</li> </ul>
	<p>6.2 Unless obtained directly from the Employer, the Employer is not responsible for the completeness of the bidding document, responses to requests for clarification, the minutes of the pre-Bid meeting (if any), or Addenda to the bidding document in accordance with ITB 8. In case of any contradiction, documents obtained directly from the Employer shall prevail.</p>
	<p>6.3 The Bidder is expected to examine all instructions, forms, terms, and specifications in the bidding document and to furnish with its Bid all information and documentation as is required by the bidding document.</p>
<p><b>7. Clarification of Bidding Document, Site Visit, Pre-Bid Meeting</b></p>	<p>7.1 A Bidder requiring any clarification of the bidding document shall contact the <i>Employer</i> in writing at the <i>Employer's</i> address <b>specified in the BDS</b> or raise its inquiries during the pre-Bid meeting if provided for in accordance with ITB 7.4. The <i>Employer</i> will respond in writing to any request for clarification, provided that such request is received prior to the deadline for submission of Bids within a period <b>specified in the BDS</b>. The <i>Employer</i> may forward copies of its response to all Bidders who have acquired the bidding document in accordance with ITB 6.3, including a description of the inquiry but without identifying its source. If so <b>specified in the BDS</b>, the Employer shall also promptly publish its response at the web page <b>identified in the BDS</b>. Should the clarification result in changes to the essential elements of the bidding document, the Employer shall amend the bidding document following the procedure under ITB 8</p>

	and ITB 22.2.
	7.2 The Bidder is advised to visit and examine the Site of works and its surroundings and obtain for itself on its own responsibility all information that may be necessary for preparing the Bid and entering into a contract for construction of the Works. The costs of visiting the Site shall be at the Bidder's own expense.
	7.3 The Bidder and any of its personnel or agents will be granted permission by the <i>Employer</i> to enter upon its premises and lands for the purpose of such visit, but only upon the express condition that the Bidder, its personnel, and agents will release and indemnify the <i>Employer</i> and its personnel and agents from and against all liability in respect thereof, and will be responsible for death or personal injury, loss of or damage to property, and any other loss, damage, costs, and expenses incurred as a result of the inspection.
	7.4 If so <b>specified in the BDS</b> , the Bidder's authorised representative is invited to attend a pre-Bid meeting and/or a Site of works visit. The purpose of the meeting will be to clarify issues and to answer questions on any matter that may be raised at that stage.
	7.5 The Bidder is requested, to submit any questions in writing, to reach the <i>Employer</i> not later than one week before the pre-Bid meeting.
	7.6 Minutes of the pre-Bid meeting, if applicable, including the text of the questions asked by Bidders, without identifying the source, and the responses given, together with any responses prepared after the meeting, will be transmitted promptly to all Bidders who have acquired the bidding document in accordance with ITB 6.3. If so <b>specified in the BDS</b> , the Employer shall also promptly publish the Minutes of the pre-Bid meeting at the web page <b>identified in the BDS</b> . Any modification to the bidding document that may become necessary as a result of the pre-Bid meeting shall be made by the <i>Employer</i> exclusively through the issue of an addendum pursuant to ITB 8 and not through the minutes of the pre-Bid meeting. Nonattendance at the pre-Bid meeting will not be a cause for disqualification of a Bidder.
<b>8. Amendment of Bidding Document</b>	8.1 At any time prior to the deadline for submission of Bids, the <i>Employer</i> may amend the bidding document by issuing addenda.
	8.2 Any addendum issued shall be part of the bidding document and shall be communicated in writing to all who have obtained the bidding document from the Employer in accordance with ITB 6.3. The Employer shall also promptly

	publish the addendum on the Employer’s web page in accordance with ITB 7.1.
	8.3 To give prospective Bidders reasonable time in which to take an addendum into account in preparing their Bids, the Employer may, at its discretion, extend the deadline for the submission of Bids, pursuant to ITB 22.2.
<b>C. Preparation of Bids</b>	
<b>9. Cost of Bidding</b>	9.1 The Bidder shall bear all costs associated with the preparation and submission of its Bid, and the <i>Employer</i> shall in no case be responsible or liable for those costs, regardless of the conduct or outcome of the Bidding process.
<b>10. Language of Bid</b>	10.1 The Bid, as well as all correspondence and documents relating to the Bid exchanged by the Bidder and the <i>Employer</i> , shall be written in the language <b>specified in the BDS</b> . Supporting documents and printed literature that are part of the Bid may be in another language provided they are accompanied by an accurate translation of the relevant passages in the language <b>specified in the BDS</b> , in which case, for purposes of interpretation of the Bid, such translation shall govern.
<b>11. Documents Comprising the Bid</b>	<p>11.1 The Bid shall comprise two Parts, namely the Technical Part and the Financial Part. These two Parts shall be submitted simultaneously in two separate sealed envelopes (two-envelope Bidding process). One envelope shall contain only information relating to the Technical Part and the other, only information relating to the Financial Part. These two envelopes shall be enclosed in a separate sealed outer envelope marked “ORIGINAL BID”.</p> <p>11.2 The <b>Technical Part</b> shall contain the following:</p> <ul style="list-style-type: none"> <li>(a) <b>Letter of Bid – Technical Part</b>, prepared in accordance with ITB 12;</li> <li>(b) <b>Bid Security</b>, in accordance with ITB 19.1;</li> <li>(c) <b>Authorization</b>: written confirmation authorizing the signatory of the Bid to commit the Bidder, in accordance with ITB 20.3;</li> <li>(d) <b>Bidder’s Eligibility</b>: documentary evidence in accordance with ITB 17.1 establishing the Bidder’s eligibility to Bid;</li> <li>(e) <b>Qualifications</b>: documentary evidence in accordance with ITB 17.2 establishing the Bidder’s qualifications to</li> </ul>

	<p>perform the Contract if its Bid is accepted;</p> <p>(f) <b>Conformity:</b> a technical proposal in accordance with ITB 16;</p> <p>(g) any other document <b>required in the BDS.</b></p> <p>11.3 The <b>Financial Part</b> shall contain the following:</p> <p>(a) <b>Letter of Bid – Financial Part:</b> prepared in accordance with ITB 12 and ITB 14;</p> <p>(b) any other document <b>required in the BDS.</b></p> <p>11.4 The Technical Part shall not include any information related to the Bid price. Where material financial information related to the Bid price is contained in the Technical Part the Bid shall be declared non-responsive and rejected.</p> <p>11.5 In addition to the requirements under ITB 11.2, Bids submitted by a JV shall include a copy of the Joint Venture Agreement entered into by all members. Alternatively, a letter of intent to execute a Joint Venture Agreement in the event of a successful Bid shall be signed by all members and submitted with the Bid, together with a copy of the proposed Agreement.</p> <p>11.6 The Bidder shall furnish in the Letter of Bid – Financial Part information on commissions and gratuities, if any, paid or to be paid to agents or any other party relating to this Bid.</p>
<p><b>12. Letters of Bid and Schedules</b></p>	<p>12.1 The Letter of Bid – Technical Part, Letter of Bid – Financial Part shall be prepared using the relevant forms furnished in Section IV, Bidding Forms. The forms must be completed without any alterations to the text, and no substitutes shall be accepted except as provided under ITB 20.3. All blank spaces shall be filled in with the information requested.</p>
<p><b>13. Alternative Bids</b></p>	<p>13.1 Unless otherwise <b>specified in the BDS</b>, alternative Bids shall not be considered.</p>
	<p>13.2 When alternative times for completion are explicitly invited, a statement to that effect will be <b>included in the BDS</b>, and the method of evaluating different alternative times for completion will be described in Section III, Evaluation and Qualification Criteria.</p>
	<p>13.3 Except as provided under ITB 13.4 below, Bidders wishing to offer technical alternatives to the requirements of the bidding document must first price the Employer’s design as described in the bidding document and shall further provide all information necessary for a complete evaluation of the alternative by the Employer, including drawings, design</p>

	<p>calculations, technical specifications, breakdown of prices, and proposed construction methodology and other relevant details. Only the technical alternatives, if any, of the Bidder with the Most Advantageous Bid conforming to the basic technical requirements shall be considered by the Employer.</p>
	<p>13.4 When <b>specified in the BDS</b>, Bidders are permitted to submit alternative technical solutions for specified parts of the Works. Such parts will be <b>identified in the BDS</b> and described in Section VII, <i>Works’ Requirements</i>. The method for their evaluation will be stipulated in Section III, <i>Evaluation and Qualification Criteria</i>.</p>
<b>14. Bid Prices and Discounts</b>	<p>14.1 The prices and discounts quoted by the Bidder in the Letter of Bid – Financial Part and in the Priced Activity Schedule or Bill of Quantities shall conform to the requirements specified below.</p>
	<p>14.2 The Bidder shall submit a Bid for the whole of the Works described in ITB 1.1 by filling in prices for all items of the Works, as identified in Section IV, <i>Bidding Forms</i>. In case of admeasurement contracts, the Bidder shall fill in rates and prices for all items of the Works described in the Bill of Quantities. Items against which no rate or price is entered by the Bidder will not be paid for by the Employer when executed and shall be deemed covered by the rates for other items and prices in the Bill of Quantities.</p>
	<p>14.3 The price to be quoted in the Letter of Bid – Financial Part, in accordance with ITB 12.1, shall be the total price of the Bid, excluding any discounts offered.</p> <p>14.4 The Bidder shall quote any discounts and indicate the methodology for their application in the Letter of Bid - Financial Part, in accordance with ITB 12.1.</p>
	<p>14.5 Unless otherwise <b>provided in the BDS</b>, and the Conditions of Contract, the prices quoted by the Bidder shall be fixed. If the prices quoted by the Bidder are subject to adjustment during the performance of the Contract in accordance with the provisions of the Conditions of Contract, the Bidder shall furnish the indices and weightages for the price adjustment formulae in the Schedule of Adjustment Data in Section IV- <i>Bidding Forms</i> and the Employer may require the Bidder to justify its proposed indices and weightings.</p> <p>14.6 If so specified in ITB 1.1, Bids are invited for individual contracts. Bidders wishing to offer discounts for the award of more than one Contract shall specify in their Bid the price reductions applicable to each package, or alternatively, to individual Contracts within the package. Discounts shall be</p>

	submitted in accordance with ITB 14.4, provided the Bids for all contracts are opened at the same time.
	14.7 All duties, taxes, and other levies payable by the Contractor under the Contract, or for any other cause, as of the date 28 days prior to the deadline for submission of Bids, shall be included in the rates and prices and the total Bid price submitted by the Bidder.
<b>15. Currencies of Bid and Payment</b>	15.1 The currency(ies) of the Bid and the currency(ies) of payments shall be the same and shall be as <b>specified in the BDS.</b>
	15.2 Bidders may be required by the Employer to justify, to the Employer's satisfaction, their local and foreign currency requirements, and to substantiate that the amounts included in the unit rates and prices and shown in the Schedule of Adjustment Data are reasonable, in which case a detailed breakdown of the foreign currency requirements shall be provided by Bidders.
<b>16. Documents Comprising the Technical Proposal</b>	16.1 The Bidder shall furnish a technical proposal in the Technical Part of the Bid including a statement of work methods, equipment, personnel, schedule and any other information as stipulated in Section IV, Bidding Forms, in sufficient detail to demonstrate the adequacy of the Bidders' proposal to meet the work's requirements and the completion time.
<b>17. Documents Establishing the Eligibility and Qualifications of the Bidder</b>	17.1 To establish Bidder's eligibility in accordance with ITB 4, Bidders shall complete the Letter of Bid, – Technical Part, included in Section IV, Bidding Forms. 17.2 In accordance with Section III, Evaluation and Qualification Criteria, to establish its qualifications to perform the Contract, the Bidder shall provide the information requested in the corresponding information sheets included in Section IV, Bidding Forms.
	17.3 If a margin of preference applies as specified in accordance with ITB 38.1, domestic Bidders, individually or in joint ventures, applying for eligibility for domestic preference shall supply all information required to satisfy the criteria for eligibility specified in accordance with ITB 38.1.
<b>18. Period of Validity of Bids</b>	18.1 Bids shall remain valid for the Bid Validity period <b>specified in the BDS.</b> The Bid Validity period starts from the date fixed for the Bid submission deadline (as prescribed by the Employer in accordance with ITB 22.1). A Bid valid for a shorter period shall be rejected by the Employer as nonresponsive.

	<p>18.2 In exceptional circumstances, prior to the expiration of the Bid validity period, the Employer may request Bidders to extend the period of validity of their Bids. The request and the responses shall be made in writing. If a Bid Security is requested in accordance with ITB 19, it shall also be extended for twenty-eight (28) days beyond the deadline of the extended validity period. A Bidder may refuse the request without forfeiting its Bid Security. A Bidder granting the request shall not be required or permitted to modify its Bid, except as provided in ITB 18.3.</p>
	<p>18.3 If the award is delayed by a period exceeding fifty-six (56) days beyond the expiry of the initial Bid validity period, the Contract price shall be determined as follows:</p> <p>(a) in the case of fixed price contracts, the Contract price shall be the Bid price adjusted by the factor <b>specified in the BDS;</b></p>
	<p>(b) in the case of adjustable price contracts, no adjustment shall be made; or</p>
	<p>(c) in any case, Bid evaluation shall be based on the Bid price without taking into consideration the applicable correction from those indicated above.</p>
<b>19. Bid Security</b>	<p>19.1 The Bidder shall furnish as part of its Technical Part of its Bid, either a Bid-Securing Declaration or a Bid Security as <b>specified in the BDS</b>, in original form and, in the case of a Bid security, in the amount and currency <b>specified in the BDS.</b></p>
	<p>19.2 A Bid-Securing Declaration shall use the form included in Section IV, Bidding Forms.</p>
	<p>19.3 <i>If a Bid Security is specified pursuant to ITB 19.1</i>, the Bid Security shall be a demand guarantee, and in any of the following forms at the Bidder's option:</p> <p>(a) Transfer through NEFT/ RTGS/ Over the counter payment or any other format as prescribed in the website of the Employer</p> <p>(b) another security <b>specified in the BDS,</b></p>
	<p>19.4 If a Bid Security or Bid-Securing Declaration is specified pursuant to ITB 19.1, any Bid not accompanied by a substantially responsive Bid Security or Bid-Securing Declaration shall be rejected by the Employer as non-responsive.</p>
	<p>19.5 If a Bid Security is specified pursuant to ITB 19.1, the Bid Security of unsuccessful Bidders shall be returned as</p>



	promptly as possible upon the successful Bidder's signing the Contract and furnishing the Performance Security.
	19.6 The Bid Security of the successful Bidder shall be returned as promptly as possible once the successful Bidder has signed the Contract and furnished the required Performance Security and.
	19.7 The Bid Security may be forfeited or the Bid-Securing Declaration executed: <ul style="list-style-type: none"> <li>(a) if a Bidder withdraws its Bid during the period of Bid validity specified by the Bidder on the Letter of Bid – Technical Part and repeated in the Letter of Bid – Financial Part or any extension thereto provided by the Bidder; or</li> <li>(b) if the successful Bidder fails to: <ul style="list-style-type: none"> <li>(i) sign the Contract in accordance with ITB 49; or</li> <li>(ii) furnish a Performance Security.</li> </ul> </li> </ul>
	19.8 The Bid Security or the Bid-Securing Declaration of a <i>JV</i> shall be in the name of the <i>JV</i> that submits the Bid. If the <i>JV</i> has not been constituted into a legally enforceable <i>JV</i> , at the time of Bidding, the Bid Security or the Bid-Securing Declaration shall be in the names of all future members as named in the letter of intent mentioned in ITB 4.1 and ITB 11.5.
	19.9 If a Bid Security is <b>not required in the BDS</b> , pursuant to ITB 19.1, and: <ul style="list-style-type: none"> <li>(a) if a Bidder withdraws its Bid during the period of Bid validity specified by the Bidder in the Letters of Bid; or</li> <li>(b) if the successful Bidder fails to: sign the Contract in accordance with ITB 49; or furnish a Performance Security;</li> </ul> <p>the Employer may, if provided for <b>in the BDS</b>, declare the Bidder ineligible to be awarded a contract by the Employer for a period of time as <b>stated in the BDS</b>.</p>
<b>20. Format and Signing of Bid</b>	20.1 The Bidder shall prepare the Bid, in accordance with the Instructions, ITB 11 and ITB 21.  20.2 Bidders shall mark as “CONFIDENTIAL” information in their Bids which is confidential to their business. This may include proprietary information, trade secrets or commercial or financially sensitive information.

	<p>20.3 The original and all copies of the Bid shall be typed or written in indelible ink and shall be signed by a person duly authorized to sign on behalf of the Bidder. This authorization shall consist of a written confirmation as <b>specified in the BDS</b> and shall be attached to the Bid. The name and position held by each person signing the authorization must be typed or printed below the signature. All pages of the Bid where entries or amendments have been made shall be signed or initialled by the person signing the Bid.</p>
	<p>20.4 In case the Bidder is a JV, the Bid shall be signed by an authorized representative of the JV on behalf of the JV, and so as to be legally binding on all the members as evidenced by a power of attorney signed by their legally authorized representatives.</p> <p>20.5 Any interlineations, erasures, or overwriting shall be valid only if they are signed or initialled by the person signing the Bid.</p>
<b>D. Submission of Bids</b>	
<b>21. Sealing and Marking of Bids</b>	<p>21.1 The Bidder shall submit the bids through e-portal. All the documents required for Technical qualification shall be submitted as per ITB and formats as per Section IV of the RFB documents. Bidder shall submit all the required documents and submit as per the standard procurement procedures of the E-portal <a href="http://etender.up.nic.in">http://etender.up.nic.in</a>.</p> <p>21.2 Financial Part shall be uploaded in the given format in web portal only.</p>
	<p>21.3 In addition, the Bidder shall submit hard copy of the Bid in the number <b>if specified in the BDS</b>. All the required documents shall be uploaded in the e-portal and Employer shall not have any liability towards the failure in uploading of the documents by the Bidder.</p> <p>21.4 The envelopes marked “ORIGINAL BID” and “BID COPIES” shall be enclosed in a separate sealed outer envelope for submission to the Employer <b>if required as BDS</b>.</p>
	<p>21.5 All inner and outer envelopes, shall:</p>

	<ul style="list-style-type: none"> <li>(a) bear the name and address of the Bidder;</li> <li>(b) be addressed to the Employer in accordance with ITB 22.1;</li> <li>(c) bear the specific identification of this Bidding process indicated in ITB 1.1; and</li> <li>(d) bear a warning not to open before the time and date for Bid opening.</li> </ul>
	21.6 If all envelopes are not sealed and marked as required, the Employer will assume no responsibility for the misplacement or premature opening of the Bid.
<b>22. Deadline for Submission of Bids</b>	22.1 Bids must be received by the <i>Employer</i> at the address and no later than the date and time <b>specified in the BDS. When so specified in the BDS</b> , Bidders shall have the option of submitting their Bids electronically. Bidders submitting Bids electronically shall follow the electronic Bid submission procedures <b>specified in the BDS</b> .
	22.2 The <i>Employer</i> may, at its discretion, extend the deadline for the submission of Bids by amending the bidding document in accordance with ITB 8, in which case all rights and obligations of the <i>Employer</i> and Bidders previously subject to the deadline shall thereafter be subject to the deadline as extended.
<b>23. Late Bids</b>	23.1 The <i>Employer</i> shall not consider any Bid that arrives after the deadline for submission of Bids, in accordance with ITB 22. Any Bid received by the <i>Employer</i> after the deadline for submission of Bids shall be declared late, rejected, and returned unopened to the Bidder.
<b>24. Withdrawal, Substitution, and Modification of Bids</b>	<p>24.1 A Bidder may withdraw, substitute, or modify its Bid after it has been submitted by sending a written notice, duly signed by an authorized representative, and shall include a copy of the authorization in accordance with ITB 20.3, (except that withdrawal notices do not require copies). The corresponding substitution or modification of the Bid must accompany the respective written notice. All notices must be:</p> <ul style="list-style-type: none"> <li>(a) prepared and submitted in accordance with ITB 20 and ITB 21 (except that withdrawal notices do not require copies), and in addition, the respective envelopes shall be clearly marked “WITHDRAWAL,” “SUBSTITUTION,” “MODIFICATION;” and</li> <li>(b) received by the Employer prior to the deadline prescribed for submission of Bids, in accordance with ITB 22.</li> </ul>

	24.2 Bids requested to be withdrawn in accordance with ITB 24.1 shall be returned unopened to the Bidders.
	24.3 No Bid may be withdrawn, substituted, or modified in the interval between the deadline for submission of Bids and the expiration of the period of Bid validity specified by the Bidder on the Letter of Bid or any extension thereof.
<b>E. Public Opening of Technical Parts of Bids</b>	
<b>25. Public Opening of Technical Parts of Bids</b>	25.1 Except in the cases specified in ITB 23 and ITB 24.2, the Employer shall publicly open and read out all Bids received by the deadline, at the date, time and place <b>specified in the BDS</b> , in the presence of Bidders` designated representatives and anyone who chooses to attend. All Bidders, or their representatives and any interested party may attend a public opening. Any specific electronic Bid opening procedures required if electronic bidding is permitted in accordance with ITB 22.1, shall be <b>as specified in the BDS</b> .
	25.2 First, the written notice of withdrawal in the envelopes marked “WITHDRAWAL” shall be opened and read out and the envelope with the corresponding Bid shall not be opened, but returned to the Bidder. No Bid withdrawal shall be permitted unless the corresponding withdrawal notice contains a valid authorization to request the withdrawal and is read out at Bid opening.  25.3 Next, envelopes marked “Substitution” shall be opened and read out and exchanged with the corresponding Bid being substituted, and the substituted Bid shall not be opened, but returned to the Bidder. No Bid substitution shall be permitted unless the corresponding substitution notice contains a valid authorization to request the substitution and is read out at Bid opening.
	25.4 Next, envelopes marked “MODIFICATION” shall be opened and read out with the corresponding Bid. No Bid modification shall be permitted unless the corresponding modification notice contains a valid authorization to request the modification and is read out at Bid opening.
	25.5 Next, all other envelopes marked “TECHNICAL PART” shall be opened one at a time. On opening the envelopes marked “TECHNICAL PART” the Employer shall read out: the name of the Bidder, the presence or the absence of a Bid Security, or Bid-Securing Declaration, if required, and whether there is a modification; and Alternative Bid - Technical Part; and any other details as the Employer may consider appropriate.
	25.6 Only Technical Parts of Bids and Alternative Bid - Technical

	<p>Parts that are read out at Bid opening shall be considered further for evaluation. The Letter of Bid- Technical Part: FINANCIAL PROPOSAL” are to be initialed by representatives of the Employer attending Bid opening in the manner <b>specified in the BDS.</b></p>
	<p>25.7 At the Bid opening the Employer shall neither discuss the merits of any Bid nor reject any Bid (except for late Bids, in accordance with ITB 23.1).</p>
	<p>25.8 The Employer shall prepare a record of the Technical Parts of Bid opening that shall include, as a minimum:</p> <ul style="list-style-type: none"> <li>(a) the name of the Bidder and whether there is a withdrawal, substitution, or modification;</li> <li>(b) the receipt of envelopes that there are no “FINANCIAL PART” submitted in the Hard Copy;</li> <li>(c) the presence or absence of a Bid Security or Bid-Securing Declaration, if one was required; and</li> <li>(d) if applicable, any Alternative Bid – Technical Part.</li> </ul> <p>25.9 The Bidders’ representatives who are present shall be requested to sign the record. The omission of a Bidder’s signature on the record shall not invalidate the contents and effect of the record. A copy of the record shall be distributed to all Bidders.</p>
<p><b>F. Evaluation of Bids – General Provisions</b></p>	
<b>26. Confidentiality</b>	<p>26.1 Information relating to the evaluation of Bids and recommendation of contract award, shall not be disclosed to Bidders or any other persons not officially concerned with the Bidding process until information on Intention to Award the Contract is transmitted to all Bidders in accordance with ITB 44.</p>
	<p>26.2 Any effort by a Bidder to influence the Employer in the evaluation of the Bids or Contract award decisions may result in the rejection of its Bid.</p>
	<p>26.3 Notwithstanding ITB 26.2, from the time of Bid opening to the time of Contract award, if a Bidder wishes to contact the <i>Employer</i> on any matter related to the Bidding process, it shall do so in writing.</p>
<b>27. Clarification of Bids</b>	<p>27.1 To assist in the examination, evaluation, and comparison of the Bids, and qualification of the Bidders, the Employer may, at its discretion, ask any Bidder for a clarification of its Bid given a reasonable time for a response. Any clarification</p>

	<p>submitted by a Bidder that is not in response to a request by the Employer shall not be considered. The Employer's request for clarification and the response shall be in writing. No change, including any voluntary increase or decrease in the prices or substance of the Bid shall be sought, offered, or permitted, except to confirm the correction of arithmetic errors discovered by the Employer in the evaluation of the Bids, in accordance with ITB 36.</p>
	<p>27.2 If a Bidder does not provide clarifications of its Bid by the date and time set in the <i>Employer's</i> request for clarification, its Bid may be rejected.</p>
<p><b>28. Deviations, Reservations, and Omissions</b></p>	<p>28.1 During the evaluation of Bids, the following definitions apply:</p> <ul style="list-style-type: none"> <li>(a) "Deviation" is a departure from the requirements specified in the bidding document;</li> <li>(b) "Reservation" is the setting of limiting conditions or withholding from complete acceptance of the requirements specified in the bidding document; and</li> <li>(c) "Omission" is the failure to submit part or all of the information or documentation required in the bidding document.</li> </ul>
<p><b>29. Nonmaterial Nonconformities</b></p>	<p>29.1 Provided that a Bid is substantially responsive, the Employer may waive any nonconformities in the Bid.</p> <p>29.2 Provided that a Bid is substantially responsive, the Employer may request that the Bidder submit the necessary information or documentation, within a reasonable period of time, to rectify nonmaterial nonconformities in the Bid related to documentation requirements. Requesting information or documentation on such nonconformities shall not be related to any aspect of the price of the Bid. Failure of the Bidder to comply with the request may result in the rejection of its Bid.</p>
	<p>29.3 Provided that a Bid is substantially responsive pursuant to ITB 31, the <i>Employer</i> shall rectify quantifiable nonmaterial nonconformities related to the Bid price. To this effect, the Bid price may be adjusted, for comparison purposes only, to reflect the price of a missing or non-conforming item or component in the manner <b>specified in the BDS</b>.</p>
<p><b>G. Evaluation of Technical Parts of Bids</b></p>	

<p><b>30. Evaluation of Technical Parts</b></p>	<p>30.1 In evaluating the Technical Parts of each Bid, the Employer shall use the criteria and methodologies listed in this ITB and Section III, Evaluation and Qualification Criteria. No other evaluation criteria or methodologies shall be permitted.</p>
<p><b>31. Determination of Responsiveness</b></p>	<p>31.1 The <i>Employer's</i> determination of a Bid's responsiveness is to be based on the contents of the Bid itself, as defined in ITB 11.</p> <p>31.2 A substantially responsive Bid is one that meets the requirements of the bidding document without material deviation, reservation, or omission. A material deviation, reservation, or omission is one that:</p> <p>(a) if accepted, would:</p> <p style="padding-left: 40px;">(i) affect in any substantial way the scope, quality, or performance of the Works specified in the Contract; or</p> <p style="padding-left: 40px;">(ii) limit in any substantial way, inconsistent with the bidding document, the Employer's rights or the Bidder's obligations under the proposed Contract; or</p> <p>(b) if rectified, would unfairly affect the competitive position of other Bidders presenting substantially responsive Bids.</p>
	<p>31.3 The Employer shall examine the technical aspects of the Bid submitted in accordance with ITB 16, in particular, to confirm that all requirements of Section VII, Works' Requirements have been met without any material deviation, reservation or omission.</p>
	<p>31.4 If a Bid is not substantially responsive to the requirements of the bidding document, it shall be rejected by the <i>Employer</i> and may not subsequently be made responsive by correction of the material deviation, reservation, or omission.</p>
<p><b>32. Qualification of the Bidder</b></p>	<p>32.1 The <i>Employer</i> shall determine to its satisfaction whether the eligible Bidders that have submitted substantially responsive Bid - Technical Parts meet the qualifying criteria specified in Section III, Evaluation and Qualification Criteria.</p>
	<p>32.2 The determination shall be based upon an examination of the documentary evidence of the Bidder's qualifications submitted by the Bidder, pursuant to ITB 17. The determination shall not take into consideration the qualifications of other firms such as the Bidder's subsidiaries, parent entities, affiliates, subcontractors (other than Specialized Subcontractors if permitted in the bidding</p>

	document), or any other firm different from the Bidder.
	32.3 If a Bidder does not meet the qualifying criteria specified in Section III, Evaluation and Qualification Criteria, its Bid shall be rejected by the Employer and may not subsequently be made responsive by correction of the material deviation, reservation, or omission.
	32.4 Only Bids that are both substantially responsive to the bidding document, and meet all Qualification Criteria shall have their “FINANCIAL PART” submitted in e-portal opened at the second public opening.
<b>33. Subcontractors</b>	<p>33.1 Unless otherwise stated <b>in the BDS</b>, the Employer does not intend to execute any specific elements of the Works by subcontractors selected in advance by the Employer.</p> <p>33.2 The subcontractor’s qualifications shall not be used by the Bidder to qualify for the Works unless their specialised parts of the Works were previously designated by the Employer <b>in the BDS</b> as can be met by subcontractors referred to hereafter as ‘Specialized Subcontractors’, in which case, the qualifications of the Specialized Subcontractors proposed by the Bidder may be added to the qualifications.</p> <p>33.3 Bidders may propose subcontracting up to the percentage of total value of contracts or the volume of works as <b>specified in the BDS</b>. Subcontractors proposed by the Bidder shall be fully qualified for their parts of the Works.</p>
<b>H. Public Opening of Financial Parts of Bids</b>	
<b>34. Public Opening of Financial Parts</b>	34.1 Following the completion of the evaluation of the Technical Parts of the Bids, and the Employer may notify in writing or upload the same in e-portal those Bidders whose Bids were considered non-responsive to the bidding document or failed to meet the Qualification Criteria, advising them of the following information:
	<p>(a) the grounds on which their Technical Part of Bid failed to meet the requirements of the bidding document;</p> <p>(b) their “FINANCIAL PART” uploaded in web portal will be not be opened; and</p>



	<p>34.2 The Employer shall, simultaneously, notify in writing or upload in e-portal those Bidders whose Technical Part have been evaluated as substantially responsive to the bidding document and met all Qualifying Criteria, advising them of the following information:</p> <ul style="list-style-type: none"> <li>(a) their Bid has been evaluated as substantially responsive to the bidding document and met the Qualification Criteria;</li> <li>(b) their “FINANCIAL PART” uploaded in e-portal will be opened at the public opening of the Financial Parts; and</li> <li>(c) notify them of the date, time and location of the second public opening of the “FINANCIAL PART” <b>as specified in the BDS.</b></li> </ul>
	<p>34.3 The opening date should allow Bidders sufficient time to make arrangements for attending the opening. The Financial Part of the Bid shall be opened publicly in the presence of Bidders’ designated representatives and anyone who chooses to attend.</p>
	<p>34.4 At this public opening the Financial Parts will be opened by the Employer in the presence of Bidders, or their designated representatives and anyone else who chooses to attend. Bidders who met the Qualification Criteria and whose bids were evaluated as substantially responsive will have their “FINANCIAL PART” opened at the second public opening. The Employer shall read out the names of each Bidder, and the total Bid prices, per contract if applicable, and any other details as the Employer may consider appropriate.</p>
	<p>34.5 The Employer shall neither discuss the merits of any Bid nor reject “FINANCIAL PART”.</p>
	<p>34.6 The Employer shall prepare a record of the Financial Part of the Bid opening that shall include, as a minimum:</p> <ul style="list-style-type: none"> <li>(a) the name of the Bidder whose Financial Part was opened;</li> <li>(b) the Bid price, per contract if applicable, including any discounts; and</li> </ul>
	<p>34.7 The Bidders whose “FINANCIAL PART” have been opened or their representatives who are present shall be requested to sign the record. The omission of a Bidder’s signature on the record shall not invalidate the contents and effect of the record. A copy of the record shall be distributed to all</p>

	Bidders.
<b>I. Evaluation of Financial Parts of Bids</b>	
<b>35. Evaluation of Financial Parts</b>	35.1 To evaluate the Financial Part, the Employer shall consider the following:
	(a) the Bid price, excluding Provisional Sums and the provision, if any, for contingencies in the Summary Bill of Quantities <sup>1</sup> for admeasurement contracts, but including Daywork <sup>2</sup> items, where priced competitively;
	(b) price adjustment for correction of arithmetic errors in accordance with ITB 36.1;
	(c) price adjustment due to discounts offered in accordance with ITB 14.4;
	(d) converting the amount resulting from applying (a) to (c) above, if relevant, to a single currency in accordance with ITB 37;
	(e) price adjustment due to quantifiable nonmaterial nonconformities in accordance with ITB 29.3; and
	(f) the additional evaluation factors are specified in Section III, Evaluation and Qualification Criteria.
	35.2 The estimated effect of the price adjustment provisions of the Conditions of Contract, applied over the period of execution of the Contract, shall not be taken into account in Bid evaluation.
	35.3 If this bidding document allows Bidders to quote separate prices for different contracts, the methodology to determine the lowest evaluated cost of the contract combinations, including any discounts offered in the Letter of Bid – Financial Part, is specified in Section III, Evaluation and Qualification Criteria
<b>36. Correction of Arithmetical Errors</b>	36.1 In evaluating the Financial Part of each Bid, the Employer shall correct arithmetical errors on the following basis:

<sup>1</sup> In lump-sum contracts, delete “Bill of Quantities” and replace with “Activity Schedule.”

<sup>2</sup> Daywork is work carried out following instructions of the Project Manager and paid for on the basis of time spent by workers, and the use of materials and the Contractor’s equipment, at the rates quoted in the Bid. For Daywork to be priced competitively for Bid evaluation purposes, the Employer must list tentative quantities for individual items to be costed against Daywork (e.g., a specific number of tractor driver staff-days, or a specific tonnage of Portland cement), to be multiplied by the Bidders’ quoted rates and included in the total Bid price.

	<p>(a) only for admeasurement contracts, if there is a discrepancy between the unit price and the total price that is obtained by multiplying the unit price and quantity, the unit price shall prevail and the total price shall be corrected, unless in the opinion of the Employer there is an obvious misplacement of the decimal point in the unit price, in which case the total price as quoted shall govern and the unit price shall be corrected;</p> <p>(b) if there is an error in a total corresponding to the addition or subtraction of subtotals, the subtotals shall prevail and the total shall be corrected; and</p> <p>(c) if there is a discrepancy between words and figures, the amount in words shall prevail, unless the amount expressed in words is related to an arithmetic error, in which case the amount in figures shall prevail subject to (a) and (b) above.</p>
	36.2 Bidders shall be requested to accept correction of arithmetical errors. Failure to accept the correction in accordance with ITB 36.1, shall result in the rejection of the Bid.
<b>37. Conversion to Single Currency</b>	37.1 For evaluation and comparison purposes, the currency(ies) of the Bids shall be converted in a single currency as <b>specified in the BDS.</b>
<b>38. Margin of Preference</b>	38.1 Unless otherwise <b>specified in the BDS</b> , a margin of preference for domestic Bidders <sup>3</sup> shall not apply.
<b>39. Comparison of Financial Parts</b>	39.1 The Employer shall compare the evaluated costs of all responsive and qualified Bids to determine the Bid that has the lowest evaluated cost.
<b>40. Abnormally Low Bids</b>	40.1 An Abnormally Low Bid is one where the Bid price, in combination with other constituent elements of the Bid, appears unreasonably low to the extent that the Bid price raises material concerns as to the capability of the Bidder to perform the Contract for the offered Bid price.

<sup>3</sup> An individual firm is considered a domestic bidder for purposes of the margin of preference if it is registered in the country of the Employer, has more than 50 percent ownership by nationals of the country of the Employer, and if it does not subcontract more than 10 percent of the contract price, excluding provisional sums, to foreign contractors. JVs are considered as domestic bidders and eligible for domestic preference only if the individual member firms are registered in the country of the Employer or have more than 50 percent ownership by nationals of the country of the Employer, and the JV shall be registered in the country of the Employer. The JV shall not subcontract more than 10 percent of the contract price, excluding provisional sums, to foreign firms. JVs between foreign and national firms will not be eligible for domestic preference.

	<p>40.2 In the event of identification of a potentially Abnormally Low Bid, the Employer shall seek written clarifications from the Bidder, including detailed price analyses of its Bid price in correlation to the subject matter of the contract, scope, proposed methodology, schedule, allocation of risks and responsibilities and any other requirements of the bidding document.</p> <p>40.3 After evaluation of the price analyses, in the event that the Employer determines that the Bidder has failed to demonstrate its capability to deliver the contract for the offered tender price, the Employer shall reject the Bid.</p>
<p><b>41. Unbalanced or Front Loaded Bids</b></p>	<p>41.1 If the Bid for an admeasurement contract, which results in the lowest evaluated cost, in the Employer’s opinion, seriously unbalanced or front loaded the Employer may require the Bidder to provide written clarifications. Clarifications may include detailed price analyses to demonstrate the consistency of the Bid prices with the scope of works, proposed methodology, schedule and any other requirements of the bidding document.</p> <p>41.2 After the evaluation of the information and detailed price analyses presented by the Bidder, the Employer may as appropriate:</p> <ul style="list-style-type: none"> <li>(a) accept the Bid; or</li> <li>(b) require that the amount of the performance security be increased at the expense of the Bidder to a level not exceeding 20% of the Contract price; or</li> <li>(c) reject the Bid.</li> </ul>
<p><b>42. Most Advantageous Bid</b></p>	<p>42.1 Having compared the evaluated costs of Bids, the Employer shall determine the Most Advantageous Bid. The Most Advantageous Bid is the Bid of the Bidder that meets the Qualification Criteria and whose Bid has been determined to be:</p> <ul style="list-style-type: none"> <li>(a) substantially responsive to the bidding document; and</li> <li>(b) the lowest evaluated cost.</li> </ul>
<p><b>43. Employer’s Right to Accept Any Bid, and to Reject Any or All Bids</b></p>	<p>43.1 The <i>Employer</i> reserves the right to accept or reject any Bid, and to annul the Bidding process and reject all Bids at any time prior to Contract Award, without thereby incurring any liability to Bidders. In case of annulment, all Bids submitted and specifically, Bid Securities, shall be promptly returned to the Bidders.</p>

<b>44. Standstill Period</b>	44.1 The Contract shall be awarded not earlier than the expiry of the Standstill Period. The duration of the Standstill Period is <b>specified in the BDS</b> . Where only one Bid is submitted, the Standstill Period shall not apply.
<b>45. Notice of Intention to Award</b>	45.1 When a Standstill Period applies, it shall commence when the Employer has transmitted to each Bidder (that has not already been notified that it has been unsuccessful) the Notification of Intention to Award the Contract to the successful Bidder. The Notification of Intention to Award shall contain, at a minimum, the following information: <ul style="list-style-type: none"> <li>(a) the name and address of the Bidder submitting the successful Bid;</li> <li>(b) the Contract price of the successful Bid;</li> <li>(c) the names of all Bidders who submitted Bids, and their Bid prices as readout, and as evaluated;</li> <li>(d) a statement of the reason(s) the Bid (of the unsuccessful Bidder to whom the letter is addressed) was unsuccessful, unless the price information in c) above already reveals the reason;</li> <li>(e) the expiry date of the Standstill Period; and</li> <li>(f) instructions on how to request a debriefing and/or submit a complaint during the standstill period.</li> </ul>
<b>J. Award of Contract</b>	
<b>46. Award Criteria</b>	46.1 Subject to ITB 43, the Employer shall award the Contract to the successful Bidder. This is the Bidder whose Bid has been determined to be the Most Advantageous Bid as specified in ITB 42.
<b>47. Notification of Award</b>	47.1 Prior to the expiration of the Bid Validity Period and upon expiry of the Standstill Period, specified in BDS ITB 44.1 or any extension thereof, or upon satisfactorily addressing a complaint that has been filed within the Standstill Period, the Employer shall transmit the Letter of Acceptance to the successful Bidder. The Letter of Acceptance shall specify the sum that the Employer will pay the Contractor in consideration of the execution of the contract (hereinafter, and in the Conditions of Contract and Contract Forms, called “the Contract Price”). <p>47.2 At the same time, the Employer shall publish the Contract Award Notice which shall contain, at a minimum, the following information:</p> <ul style="list-style-type: none"> <li>(a) name and address of the Employer;</li> </ul>

	<p>(b) name and reference number of the contract being awarded, and the selection method used;</p> <p>(c) names of all Bidders that submitted Bids, and their Bid prices as read out at Bid opening, and as evaluated;</p> <p>(d) names of all Bidders whose Bids were rejected either as nonresponsive or as not meeting qualification criteria, or were not evaluated, with the reasons therefor; and</p> <p>(e) the name of the successful Bidder, the final total contract price, the contract duration and a summary of its scope.</p> <p>47.3 The Contract Award Notice shall be published on the Employer’s website with free access.</p> <p>47.4 Until a formal Contract is prepared and executed, the Letter of Acceptance shall constitute a binding Contract.</p>
<b>48. Debriefing by the Employer</b>	<p>48.1 On receipt of the Employer’s Notification of Intention to Award referred to in ITB 45.1, an unsuccessful Bidder has three (3) Business Days to make a written request to the Employer for a debriefing. The Employer shall provide a debriefing to all unsuccessful Bidders whose request is received within this deadline.</p>
	<p>48.2 Where a request for debriefing is received within the deadline, the Employer shall provide a debriefing within five (5) Business Days, unless the Employer decides, for justifiable reasons, to provide the debriefing outside this timeframe. In that case, the standstill period shall automatically be extended until five (5) Business Days after such debriefing is provided. If more than one debriefing is so delayed, the standstill period shall not end earlier than five (5) Business Days after the last debriefing takes place. The Employer shall promptly inform, by the quickest means available, all Bidders of the extended standstill period</p>
	<p>48.3 Where a request for debriefing is received by the Employer later than the three (3)-Business Day deadline, the Employer should provide the debriefing as soon as practicable, and normally no later than fifteen (15) Business Days from the date of publication of Public Notice of Award of contract. Requests for debriefing received outside the three (3)-day deadline shall not lead to extension of the standstill period.</p>
	<p>48.4 Debriefings of unsuccessful Bidders may be done in writing or verbally. The Bidder shall bear their own costs of attending such a debriefing meeting.</p>
<b>49. Signing of</b>	<p>49.1 Promptly upon Notification of Award, the Employer shall</p>

<b>Contract</b>	send the successful Bidder the Contract Agreement.
	49.2 Within twenty-eight (28) days of receipt of the Contract Agreement, the successful Bidder shall sign, date, and return it to the Employer.
<b>50. Performance Security</b>	50.1 Within twenty-eight (28) days of the receipt of the Letter of Acceptance from the Employer, the successful Bidder shall furnish the Performance Security, in accordance with the General Conditions of Contract, subject to ITB 41.2 (b), using for that purpose the Performance Security, Contract Forms, or another form acceptable to the Employer. If the Performance Security furnished by the successful Bidder is in the form of a bond, it shall be issued by a bonding or insurance company that has been determined by the successful Bidder to be acceptable to the Employer. A foreign institution providing a bond shall have a correspondent financial institution located in the Employer's Country, unless the Employer has agreed in writing that a correspondent financial institution is not required.
	50.2 Failure of the successful Bidder to submit the above-mentioned Performance Security, or to sign the Contract Agreement shall constitute sufficient <i>grounds</i> for the annulment of the award and forfeiture of the Bid Security. In that event the Employer may award the Contract to the Bidder offering the next Most Advantageous Bid.
<b>51. Adjudicator</b>	51.1 The Employer proposes the person named <b>in the BDS</b> to be appointed as Adjudicator under the Contract, at the hourly fee <b>specified in the BDS</b> , plus reimbursable expenses. If the Bidder disagrees with this proposal, the Bidder should so state in his Bid. If, in the Letter of Acceptance, the Employer does not agree on the appointment of the Adjudicator, the Employer will request the Appointing Authority designated in the Particular Conditions of Contract (PCC) pursuant to Clause 23.1 of the General Conditions of Contract (GCC), to appoint the Adjudicator.
<b>52. Procurement Related Complaint</b>	52.1 The procedures for making a Procurement-related Complaint are as specified in the BDS.





## Section II - Bid Data Sheet (BDS)

<b>A. General</b>	
<b>ITB 1.1</b>	<p>The reference number of the Request for Bids (RFB) is:: _____</p> <p>The Employer is: <i>Aligarh Smart City Limited</i></p> <p>The name of the RFB is: Design, Manufacture, Supply, Installation and Commissioning of Different Capacity Roof Top Solar PV Power Projects under Net Metering Policy in Aligarh City (Smart City Mission)</p>
<b>ITB 1.2 (a)</b>	The number and identification of comprising this RFB is:
<b>ITB 1.2(a)</b>	<p><b>Electronic –Procurement System</b></p> <p>The Employer shall use the following electronic-procurement system to manage this Bidding process:</p> <p><a href="https://etender.up.nic.in">https://etender.up.nic.in</a></p> <p>The electronic-procurement system shall be used to manage the following aspects of the Bidding process:</p> <ul style="list-style-type: none"> <li>• Technical Proposal containing all the required documents in the required formats.</li> <li>• Financial Proposal: The Priced Bid shall be uploaded through web-portal only.</li> </ul>
<b>ITB 2.1</b>	The name of the Project is: Design, Manufacture, Supply, Installation and Commissioning of Different Capacity Roof Top Solar PV Power Projects under Net Metering Policy in Aligarh City (Smart City Mission)
<b>ITB 4.1</b>	Maximum number of members in the JV shall be: <i>Maximum of 2 with equal share in the JV.</i>
<b>B. Contents of Bidding Document</b>	
<b>ITB 7.1</b>	<p>For <b><u>clarification purposes</u></b> only, the Employer’s address is:</p> <p>Attention: <i>Chief Executive Officer</i></p> <p>Nagar Nigam Aligarh Room no 108, Sewa Bhawan, Near Ghanta Ghar Church Compound, Civil Lines, Lal Diggi Road, Aligarh, Uttar Pradesh 202001, India</p> <p>PIN Code: 202001, Telephone: 0571-2401807, 2405520</p>

	<p>Electronic mail address: <i>aligarhsmartcityltd@gmail.com</i></p> <p>Requests for clarification should be received by the Employer no later than: <b>5 days (five days)</b>.</p>
<b>ITB 7.1</b>	<p>Requests for clarification should be received by the Employer no later than: <b>5 days (five days)</b>.</p> <p>Web page: <a href="https://etender.up.nic.in">https://etender.up.nic.in</a></p>
<b>ITB 7.4</b>	<p>A Pre-Bid meeting “<i>shall</i>” take place at the following date, time and place:</p> <p>Date: <b>05-09-2018, 1500 hrs</b></p> <p>Place: Nagar Nigam Aligarh</p> <p>Room no 108, Sewa Bhawan, Near Ghanta Ghar</p> <p>Church Compound, Civil Lines, Lal Diggi Road,</p> <p>Aligarh, Uttar Pradesh 202001, India</p>
<b>ITB 7.6</b>	<p>Web page: <a href="https://etender.up.nic.in">https://etender.up.nic.in</a></p>
<b>C. Preparation of Bids</b>	
<b>ITB 10.1</b>	<p>The language of the Bid is: <i>English</i></p> <p>All correspondence exchange shall be in <i>English</i> language.</p> <p>Language for translation of supporting documents and printed literature is <i>English</i></p>
<b>ITB 11.2 (h)</b>	<p>Total monetary value of similar work performed for each of the last seven years;</p> <p><b><u>Similar Work is defined as:</u></b></p> <p>Design, manufacturing, supplying, installing, commissioning and maintaining at least SPV Power Plants of aggregate capacity <b>0.9 MWp</b> in last three years up to the last date of bidding and is in successful operation in India. Bidder is required to submit the proof of their eligibility in the form of work order, commissioning certificate from the Client, satisfactory operation reports copies and establishment details along with the tender bid in its technical bid.</p> <p><b><u>Other Conditions</u></b></p> <p>(a) Experience in works of similar nature and size for each of the last seven years, and details of works underway or contractually committed with their certificates from the concerned officer not less the rank of Executive Engineer or Equivalent. A list of clients with their contact details, who may be contacted for further information on those contracts, shall also be provided.</p>

	<p>(b) Major items of construction equipment proposed to carry out the Contract;</p> <p>(c) Qualifications and experience of key site management and technical personnel proposed for Contract;</p> <p>Reports on the financial standing of the Bidder, such as profit and loss statements and auditor's reports for the past three years;</p> <p>(d) Authority may seek references from the Bidder's bankers;</p> <p>(e) Information regarding any litigation, current or during the last seven years, in which the Bidder is involved, the parties concerned, and disputed Amount</p> <p>(f) Self-certified copy that none of the members has not been Debarred / Black Listed by the Government of India or any State Government in India and no bar subsists as on the Application Due Date.</p>
<b>ITB 11.3 (b)</b>	The following schedules shall be submitted with the Bid: <b><i>Time Schedule for Project.</i></b>
<b>ITB 14.5</b>	The prices quoted by the Bidder <b><i>shall not be</i></b> subject to adjustment during the performance of the Contract.
<b>ITB 15.1</b>	The price shall be quoted by the Bidder in: <b><i>Indian Rupees</i></b>
<b>ITB 18.1</b>	The Bid validity period shall be <b><i>120</i></b> days.
<b>ITB 19.1</b>	<p>A Bid Security <b><i>shall be</i></b> required.</p> <p>If a Bid Security/EMD shall be required, the amount and currency of the Bid Security shall be: <b>INR 12,23,880/- (Rupees Twelve Lakhs Twenty Three Thousand Eight Hundred and Eight Only)</b></p> <p><b>Bid Document fee of INR 5,000/- (Rupees Five Thousand only) is also to be deposited separately.</b></p>
<b>ITB 19.3 (d)</b>	<p>Other types of acceptable securities:</p> <p>(a) <b><i>NEFT/RTGS</i></b></p> <p>(b) <b><i>Net Banking</i></b></p> <p><b>Name: Aligarh Smart City Limited, Account no: 0294001100000818, IFSC:PUNB0001000, , MICR Code: 202024002</b></p>
<b>ITB 19.9</b>	If the Bidder performs any of the actions prescribed in ITB 19.9 (a) or (b), the Employer will declare the Bidder <b><i>ineligible</i></b> to be awarded contracts by the Employer for a period of <b><i>3</i></b> years.
<b>ITB 20.3</b>	The written confirmation of authorization to sign on behalf of the Bidder shall consist of; <b><i>Duly executed Power of Attorney in favour of person</i></b>

	<i>who is submitting the Bid</i>
<b>D. Submission of Bids</b>	
<b>ITB 21.2</b>	In addition to the original of the Bid, the number of copies is: <b>Zero (0)</b> .
<b>ITB 22.1</b>	<p>For <b><u>Bid submission purposes</u></b> only, the Employer’s address is:  Street Address: Nagar Nigam Aligarh  Room no 108, Sewa Bhawan, Near Ghanta Ghar  Church Compound, Civil Lines, Lal Diggi Road,  Aligarh, Uttar Pradesh 202001, India  PIN Code: 202001, Telephone: 0571-2401807, 2405520  Date: 12-09-2018, Time: 1700 Hrs</p> <p>Bidders “<i>shall</i>” <b>mandatorily submit all the copies of the Bid vide web portal.</b></p> <p>The electronic bidding submission procedures shall be:  The bidder would be required to register on the e-procurement market place <a href="https://etender.up.nic.in">https://etender.up.nic.in</a> and submit their bids online. Bidders are requested to submit the bid in two stages:  Stage – I: Eligibility and Technical Bid Stage.  Stage – II: Financial Bid Stage.</p> <ul style="list-style-type: none"> <li>• The first stage will cover the qualifications and eligibility criteria and the technical bid. The bidder shall upload documents in support of the above. The bidder shall submit price bid online under second stage which may include proposals for financing to cover part of the Scope of Work as per bid documents before the bid submission closing date.</li> <li>• Bidders shall submit a declaration without any reservation whatsoever that the submitted eligibility and qualification details, Techno-Commercial bid and financial bid are without any deviations and are strictly in conformity with the bid documents issued by the Employer.</li> <li>• Declaration should be given by the bidder for the correctness of the credentials submitted by him.</li> </ul>
<b>E. Public Opening of Technical Parts of Bids</b>	
<b>ITB 25.1</b>	<p>The Bid opening shall take place at:  Street Address: Nagar Nigam Aligarh  Room no 108, Sewa Bhawan, Near Ghanta Ghar  Church Compound, Civil Lines, Lal Diggi Road,  Aligarh, Uttar Pradesh 202001, India  Date: 14-09-2018, Time: 1500 Hrs</p>

<b>ITB 25.1</b>	The electronic Bid opening procedures shall be: <i><b>Bid opening will be as per the e-procurement procedures.</b></i>
<b>F. Evaluation of Bids – General Provisions</b>	
<b>ITB 29.3</b>	<i>Not Applicable</i>
<b>G. Evaluation of Bids - Technical Parts</b>	
<b>ITB 33.1</b>	At this time the Employer to execute certain specific parts of the Works by subcontractors selected in advance- <i>None</i>
<b>ITB 33.3</b>	Contractor’s proposed subcontracting: <i>None</i>
<b>H. Public Opening of Financial Parts</b>	
<b>ITB 34.2 (c)</b>	Following the completion of the evaluation of the Technical Parts of the Bids, the Employer will notify vide the e-portal mentioning of the location, date and time of the public opening of Financial Bid.  The Employer shall publish a notice of the public opening of the Financial Bids on its website.
<b>I. Evaluation of Bids - Financial Parts</b>	
<b>ITB 37.1</b>	The currency that shall be used for Bid evaluation and comparison purposes to convert at the selling exchange rate all Bid prices expressed in various currencies into a single currency is: <i><b>Indian Rupees(INR)</b></i>  The source of exchange rate shall be: <i><b>Reserve Bank of India</b></i>  The date for the exchange rate shall be: <i><b>28 days before the Submission of Bid</b></i>
<b>ITB 44</b> <b>Standstill</b> <b>Period</b>	<i>Not Applicable</i>
<b>J. Award of Contract</b>	
<b>ITB 51</b> <b>Adjudicator</b>	The Adjudicator proposed by the Employer is: to be proposed later.

## **Section III - Evaluation and Qualification Criteria**

Eligibility and Qualification Criteria			Compliance Requirements				Documentation
No.	Subject	Requirement	Single Entity	Joint Venture (existing or intended)			Submission Requirements
				All members Combined	Each member	At least one member	
<b>1. Eligibility</b>							
1.1	Nationality	Nationality in accordance with ITB 4	Must meet requirement	N/A	N/A	N/A	Forms ELI – 1.1 and 1.2, with attachments
1.2	Conflict of Interest	No conflicts of interest in accordance with ITB 4	Must meet requirement	N/A	N/A	N/A	Letter of Bid
1.3	Employer Eligibility	Not having been declared ineligible by the Employer, as described in ITB 4.	Must meet requirement	N/A	N/A	N/A	Letter of Bid
1.4	State-owned enterprise or institution of the Employer country	Meets conditions of ITB 4	Must meet requirement	N/A	N/A	N/A	Forms ELI – 1.1 and 1.2, with attachments

Eligibility and Qualification Criteria			Compliance Requirements				Documentation
No.	Subject	Requirement	Single Entity	Joint Venture (existing or intended)			Submission Requirements
				All members Combined	Each member	At least one member	
<b>1. Historical Contract Non-Performance</b>							
2.1	History of Non-Performing Contracts	Non-performance of a contract <sup>1</sup> did not occur as a result of contractor default since 10 years prior to 30 days from the due date of Bidding.	Must meet requirement <sup>1 and 2</sup>	Must meet requirement <sup>1 and 2</sup>	Must meet requirement <sup>1 and 2</sup>	Must meet requirement <sup>1 and 2</sup>	Form CON-2
2.2	Suspension Based on Execution of Bid/Proposal Securing Declaration by the Employer or withdrawal of the Bid within Bid validity period	Not under suspension based on execution of a Bid/Proposal Securing Declaration pursuant to ITB 4 or withdrawal of the Bid pursuant ITB 19.9.	Must meet requirement	Must meet requirement	Must meet requirement	Must meet requirement	Letter of Bid
2.3	Pending Litigation	Bidder's financial position and prospective long term profitability sound according to criteria established in 3.1 below and assuming that all pending litigation will be resolved against the Bidder	Must meet requirement	Must meet requirement	Must meet requirement	Must meet requirement	Form CON – 2
2.4	Litigation	No consistent history of	Must meet	Must meet	Must meet	Must meet	Form CON – 2

<sup>1</sup> Non-performance, as decided by the Employer, shall include all contracts where (a) non performance was not challenged by the contractor, including through referral to the dispute resolution mechanism under the respective contract, and (b) contracts that were so challenged but fully settled against the contractor. Non performance shall not include contracts where Employers decision was overruled by the dispute resolution mechanism. Non performance must be based on all information on fully settled disputes or litigation, i.e. dispute or litigation that has been resolved in accordance with the dispute resolution mechanism under the respective contract and where all appeal instances available to the Bidder have been exhausted.



Eligibility and Qualification Criteria			Compliance Requirements				Documentation
No.	Subject	Requirement	Single Entity	Joint Venture (existing or intended)			Submission Requirements
				All members Combined	Each member	At least one member	
	History	court/arbitral award decisions against the Bidder <sup>2</sup> since 10 years prior to 30 days from the due date of Bidding.	requirement	requirement	requirement	requirement	
<b>3. Financial Situation and Performance</b>							
3.1	Financial Capabilities	The Bidder shall demonstrate that it has access to, or has available, liquid assets, unencumbered real assets, lines of credit, and other financial means (independent of any contractual advance payment) sufficient to meet the construction cash flow requirements estimated as <b>INR 25%</b> of the estimated contract value for the subject contract(s) net of the Bidder's other commitments	Must meet requirement	Must meet requirement	N/A	Must meet requirement	Form FIN – 3.1, with attachments
		The audited balance sheets for the last 3years shall be submitted and must demonstrate the current soundness of the Bidder's financial position and <b>shall be a profit making organisation.</b>	Must meet requirement	Must meet requirement	N/A	Must meet requirement	
3.2	Average Annual Turnover	Minimum average annual turnover of <b>INR 245 Lakhs</b>	Must meet requirement	Must meet requirement	N/A	Must meet requirement	Form FIN – 3.2

<sup>2</sup> The Bidder shall provide accurate information on the letter of Bid about any litigation or arbitration resulting from contracts completed or ongoing under its execution over the last five years. A consistent history of court/arbitral awards against the Bidder or any member of a joint venture may result in disqualifying the Bidder.

Eligibility and Qualification Criteria			Compliance Requirements				Documentation
No.	Subject	Requirement	Single Entity	Joint Venture (existing or intended)			Submission Requirements
				All members Combined	Each member	At least one member	
		(Rupees Two Crores Forty Five Lakhs Only), calculated as total turnover received within the last 3 years, divided by 3 years					
<b>4. Experience</b>							
4.1 (a)	General Construction Experience	Experience under construction contracts in the role of prime contractor, JV member, nominated sub-contractor, or management contractor for at least the last 1 year, starting 10 years prior to 30 days from the due date of Bidding.	Must meet requirement	Must meet requirement	Must meet requirement	Must meet requirement	Form EXP – 4.1
4.2 (a)	Specific Construction & Contract Management Experience	(i) A minimum Works means <b>Similar Completed Works</b> as a prime contractor, joint venture member <sup>3</sup> , management contractor or nominated sub-contractor <sup>3</sup> between 10 years prior to 30 days from the due date of Bidding:  <u><b>Completed Similar Work :</b></u> <u><b>Similar Works defined as BDS 11.2 (h)</b></u>  <b>1(One) number similar completed work each of 80%</b>	Must meet requirements	Must meet requirements	N/A	Must meet requirements	Form EXP 4.2(a)

<sup>3</sup> For contracts under which the Bidder participated as a joint venture member or sub-contractor, only the Bidder's share, by value, shall be considered to meet this requirement.

Eligibility and Qualification Criteria			Compliance Requirements			Documentation	
No.	Subject	Requirement	Single Entity	Joint Venture (existing or intended)			Submission Requirements
				All members Combined	Each member	At least one member	
		<p><i>(excluding the cost of the land) in a single contract.</i></p> <p><b>OR</b></p> <p><i>2(Two) numbers similar completed works each of 50%(excluding the cost of the land) in two different contract.</i></p> <p><b>OR</b></p> <p><i>3(three) numbers similar completed works each of 40% (excluding the cost of the land) in three different contracts.</i></p>					

## 5. Key Personnel

The Bidder must demonstrate that it will have a suitably qualified (and in adequate numbers) minimum Key Personnel, as described in the table below, that are required to perform the Contract.

The Bidder shall provide details of the Key Personnel and such other Key Personnel that the Bidder considers appropriate, together with their academic qualifications and work experience. The Bidder shall complete the relevant Forms in Section IV, Bidding Forms.

The Contractor shall require the Employer’s consent to substitute or replace the Key Personnel (reference the Particular Conditions of Contract 9.1).

### Key Personnel

No.	Position	Total Work Similar Experience (years)	Nos
1	Project Manager	B.E Mechanical/ Electrical+7 Year experience	1 Nos
2	Site Engineer	B.E Mechanical/ Electrical +3 Year experience or Diploma Mechanical/ Electrical + 5 Year experience	1 Nos
3	Supervisors	Diploma Mechanical/ Electrical + 3 Year experience	2 Nos
4	Foreman	Having similar experience works of at least 5 years	2 Nos
5	Welders	Having 2 years of similar experience with required certification	1 Nos

## 6. Equipment

The Bidder must demonstrate that it has the key equipment listed hereafter:

S. No	Type of Equipment	Maximum age as on 31.03.2018 (years)	Minimum Nos.
1	Welding sets	-(preferably new)	01 Nos
2	Water Tanker	-(preferably new)	03 Nos
3	DG sets	-(preferably new)	02 nos

The Bidder shall provide further details of proposed items of equipment using Form EQU in Section IV, Bidding Forms.

## Section IV - Bidding Forms

### Table of Forms

<b>Letter of Bid - Technical Part .....</b>	<b>45</b>
<b>Appendix B to Technical Part: Equipment.....</b>	<b>47</b>
<b>Appendix C to Technical Part: Key Personnel.....</b>	<b>48</b>
Form PER -1: Key Personnel .....	49
Form PER-2: Resume and Declaration .....	51
<b>Appendix D to Technical Part: Bidder’s Qualification .....</b>	<b>53</b>
Form ELI -1.1 .....	54
Form ELI -1.2.....	55
Form CON – 2.....	56
Form FIN – 3.1 .....	58
Form FIN - 3.2: .....	59
Form FIN – 3.3.....	60
Form FIN – 3.4.....	61
Form EXP - 4.1 .....	62
Form EXP - 4.2(a) .....	63
Form EXP - 4.2(a) (cont.) .....	64
<b>Letter of Bid - Financial Part .....</b>	<b>65</b>

## Letter of Bid - Technical Part

**Date of this Bid submission:** *[insert date (as day, month and year) of Bid submission]*

**Request for Bid No.:** *[insert identification]*

To:

*Chief Executive Officer*

*Nagar Nigam Aligarh*

*Sewa Bhawan, Near Ghanta Ghar*

*Church Compound, Civil Lines, Lal Diggi Road,*

*Aligarh, Uttar Pradesh 202001, India*

*PIN Code: 202001, Telephone: 0571-2401807, 2405520*

We, the undersigned, hereby submit our Bid, in two parts, namely:

- (a) the Technical Part, and
- (b) the Financial Part

In submitting our Bid, we make the following declarations:

- (a) **No reservations:** We have examined and have no reservations to the bidding document, including Addenda issued in accordance with Instructions to Bidders (ITB 8);
- (b) **Eligibility:** We meet the eligibility requirements and have no conflict of interest in accordance with ITB 4;
- (c) **Bid-Securing Declaration:** We have not been suspended nor declared ineligible by the Employer based on execution of a Bid-Securing Declaration or Proposal-Securing Declaration in the Employer's country in accordance with ITB 4.7;
- (d) **Conformity:** We offer to execute in conformity with the bidding document the following Works: *[insert a brief description of the Works]* \_\_\_\_\_  
\_\_\_\_\_;
- (e) **Bid Validity Period:** Our Bid shall be valid for a period specified in BDS 18.1 (or as amended if applicable) from the date fixed for the Bid submission deadline specified in BDS 22.1 (or as amended if applicable), and it shall remain binding upon us and may be accepted at any time before the expiration of that period;
- (f) **Performance Security:** If our Bid is accepted, we commit to obtain a Performance Security in accordance with the bidding document;
- (g) **One Bid Per Bidder:** We are not submitting any other Bid(s) as an individual Bidder or as a subcontractor, and we are not participating in any other Bid(s) as a Joint Venture member, and meet the requirements of ITB 4.3, other than alternative Bids submitted in accordance with ITB 13;

- (h) **State-owned enterprise or institution:** *[select the appropriate option and delete the other]*  
*[We are not a state-owned enterprise or institution] / [We are a state-owned enterprise or institution but meet the requirements of ITB 4.6];*
- (i) **Binding Contract:** We understand that this Bid, together with your written acceptance thereof included in your Letter of Acceptance, shall constitute a binding contract between us, until a formal contract is prepared and executed;
- (j) **Not Bound to Accept:** We understand that you are not bound to accept the lowest evaluated cost Bid, the Most Advantageous Bid or any other Bid that you may receive; and
- (k) **Fraud and Corruption:** We hereby certify that we have taken steps to ensure that no person acting for us or on our behalf engages in any type of Fraud and Corruption;

**Name of the Bidder:** *\*[insert complete name of person signing the Bid]*

**Name of the person duly authorized to sign the Bid on behalf of the Bidder:** *\*\* [insert complete name of person duly authorized to sign the Bid]*

**Title of the person signing the Bid:** *[insert complete title of the person signing the Bid]*

**Signature of the person named above:** *[insert signature of person whose name and capacity are shown above]*

**Date signed** *[insert date of signing]* **day of** *[insert month]*, *[insert year]*

Date signed \_\_\_\_\_ day of \_\_\_\_\_,

\*: In the case of the Bid submitted by joint venture specify the name of the Joint Venture as Bidder

\*\*: Person signing the Bid shall have the power of attorney given by the Bidder to be attached with the Bid

## Appendix B to Technical Part: Equipment

The Bidder shall provide adequate information to demonstrate clearly that it has the capability to meet the requirements for the key equipment listed in Section III, Evaluation and Qualification Criteria. A separate Form shall be prepared for each item of equipment listed, or for alternative equipment proposed by the Bidder.

Item of equipment		
Equipment information	Name of manufacturer	Model and power rating
	Capacity	Year of manufacture
Current status	Current location	
	Details of current commitments	
Source	Indicate source of the equipment (a) <input type="checkbox"/> Owned <input type="checkbox"/> Rented <input type="checkbox"/> Leased <input type="checkbox"/> Specially manufactured	

Omit the following information for equipment owned by the Bidder.

Owner	Name of owner	
	Address of owner	
	Telephone	Contact name and title
	Fax	Telex
Agreements	Details of rental / lease / manufacture agreements specific to the project	





## **Appendix C to Technical Part: Key Personnel**

Form PER -1: Key Personnel

# Schedule

Bidders should provide the names and details of the suitably qualified Key Personnel to perform the Contract. The data on their experience should be supplied using the Form PER-2 below for each candidate.

## Key Personnel

1.	<b>Title of position:</b>	
	<b>Name of candidate:</b>	
	<b>Duration of appointment:</b>	<i>[insert the whole period (start and end dates) for which this position will be engaged]</i>
	<b>Time commitment for this position:</b>	<i>[insert the number of days/week/months/ that has been scheduled for this position]</i>
	<b>Expected time schedule for this position:</b>	<i>[insert the expected time schedule for this position (e.g. attach high level Gantt chart)]</i>
2.	<b>Title of position:</b>	
	<b>Name of candidate:</b>	
	<b>Duration of appointment:</b>	<i>[insert the whole period (start and end dates) for which this position will be engaged]</i>
	<b>Time commitment for this position:</b>	<i>[insert the number of days/week/months/ that has been scheduled for this position]</i>
	<b>Expected time schedule for this position:</b>	<i>[insert the expected time schedule for this position (e.g. attach high level Gantt chart)]</i>
3.	<b>Title of position:</b>	
	<b>Name of candidate:</b>	
	<b>Duration of appointment:</b>	<i>[insert the whole period (start and end dates) for which this position will be engaged]</i>
	<b>Time commitment for this position:</b>	<i>[insert the number of days/week/months/ that has been scheduled for this position]</i>
	<b>Expected time schedule for this position:</b>	<i>[insert the expected time schedule for this position (e.g. attach high level Gantt chart)]</i>
4.	<b>Title of position:</b>	
	<b>Name of candidate:</b>	
	<b>Duration of appointment:</b>	<i>[insert the whole period (start and end dates) for which this position will be engaged]</i>
	<b>Time commitment for this position:</b>	<i>[insert the number of days/week/months/ that has been scheduled for this position]</i>
	<b>Expected time schedule for this position:</b>	<i>[insert the expected time schedule for this position (e.g. attach high level Gantt chart)]</i>
5.	<b>Title of position:</b> <i>[insert title]</i>	

<b>Name of candidate</b>	
<b>Duration of appointment:</b>	<i>[insert the whole period (start and end dates) for which this position will be engaged]</i>
<b>Time commitment for this position:</b>	<i>[insert the number of days/week/months/ that has been scheduled for this position]</i>
<b>Expected time schedule for this position:</b>	<i>[insert the expected time schedule for this position (e.g. attach high level Gantt chart)]</i>

## Form PER-2: Resume and Declaration Key Personnel

Name of Bidder
----------------

Position [#1]: <i>[title of position from Form PER-1]</i>		
Personnel information	Name:	Date of birth:
	Address:	E-mail:
	Professional qualifications:	
	Academic qualifications:	
	Language proficiency: <i>[language and levels of speaking, reading and writing skills]</i>	
	Details	
	Address of employer:	
	Telephone:	Contact (manager / personnel officer):
	Fax:	
	Job title:	Years with present employer:

Summarize professional experience in reverse chronological order. Indicate particular technical and managerial experience relevant to the project.

Project	Role	Duration of involvement	Relevant experience
<i>[main project details]</i>	<i>[role and responsibilities on the project]</i>	<i>[time in role]</i>	<i>[describe the experience relevant to this position]</i>

## Declaration

I, the undersigned Key Personnel, certify that to the best of my knowledge and belief, the information contained in this Form PER-2 correctly describes myself, my qualifications and my experience.

I confirm that I am available as certified in the following table and throughout the expected time schedule for this position as provided in the Bid:

<b>Commitment</b>	<b>Details</b>
<b>Commitment to duration of contract:</b>	<i>[insert period (start and end dates) for which this Key Personnel is available to work on this contract]</i>
<b>Time commitment:</b>	<i>[insert the number of days/week/months/ that this Key Personnel will be engaged]</i>

I understand that any misrepresentation or omission in this Form may:

- (a) be taken into consideration during Bid evaluation;
- (b) my disqualification from participating in the Bid;
- (c) my dismissal from the contract.

**Name of Key Personnel:** *[insert name]*

Signature: \_\_\_\_\_

Date: (day month year): \_\_\_\_\_

**Countersignature of authorized representative of the Bidder:**

Signature: \_\_\_\_\_

**Date: (day month year):** \_\_\_\_\_

## **Appendix D to Technical Part: Bidder's Qualification**

To establish its qualifications to perform the contract in accordance with Section III (Evaluation and Qualification Criteria) the Bidder shall provide the information requested in the corresponding Information Sheets included hereunder.

<p><b>Form ELI -1.1</b>  <b>Bidder Information Form</b></p>	
<p>Date: _____</p> <p>RFB _____ No. _____ and _____ title: _____</p> <p>Page _____ of _____ pages</p>	
<p>Bidder's name _____</p>	
<p>In case of Joint Venture (JV), name of each member: _____</p>	
<p>Bidder's actual or intended country of registration:  <i>[indicate country of Constitution]</i></p>	
<p>Bidder's actual or intended year of incorporation: _____</p>	
<p>Bidder's legal address [in country of registration]: _____</p>	
<p>Bidder's authorized representative information</p> <p>Name: _____</p> <p>Address: _____</p> <p>Telephone/Fax numbers: _____</p> <p>E-mail address: _____</p>	
<p>1. Attached are copies of original documents of</p> <p><input type="checkbox"/> Articles of Incorporation (or equivalent documents of constitution or association), and/or documents of registration of the legal entity named above, in accordance with ITB 4.4.</p> <p><input type="checkbox"/> In case of JV, letter of intent to form JV or JV agreement, in accordance with ITB 4.1.</p> <p><input type="checkbox"/> In case of state-owned enterprise or institution, in accordance with ITB 4.6 documents establishing:</p> <ul style="list-style-type: none"> <li>• Legal and financial autonomy</li> <li>• Operation under commercial law</li> <li>• Establishing that the Bidder is not under the supervision of the Employer</li> </ul> <p>2. Included are the organizational chart, a list of Board of Directors, and the beneficial ownership.</p>	

**Form ELI -1.2**

**Bidder's JV Information Form**  
 (to be completed for each member of Bidder's JV)

Date: \_\_\_\_\_  
 RFB No. \_\_\_\_\_ and title: \_\_\_\_\_  
 Page \_\_\_\_\_ of \_\_\_\_\_ pages

Bidder's JV name:
JV member's name:
JV member's country of registration:
JV member's year of constitution:
JV member's legal address in country of constitution:
JV member's authorized representative information Name: _____ Address: _____ Telephone/Fax numbers: _____ E-mail address: _____
1. Attached are copies of original documents of <input type="checkbox"/> Articles of Incorporation (or equivalent documents of constitution or association), and/or registration documents of the legal entity named above, in accordance with ITB 4.4. <input type="checkbox"/> In case of a state-owned enterprise or institution, documents establishing legal and financial autonomy, operation in accordance with commercial law, and that they are not under the supervision of the Employer, in accordance with ITB 4.6. 2. Included are the organizational chart, a list of Board of Directors, and the beneficial ownership.



**Form CON – 2**

**Historical Contract Non-Performance, Pending Litigation and Litigation History**

Bidder's Name: \_\_\_\_\_  
 Date: \_\_\_\_\_  
 JV Member's Name \_\_\_\_\_  
 RFB No. and title: \_\_\_\_\_  
 Page \_\_\_\_\_ of \_\_\_\_\_ pages

Non-Performed Contracts in accordance with Section III, Evaluation and Qualification Criteria			
<input type="checkbox"/> Contract non-performance did not occur since 1 <sup>st</sup> January <i>[insert year]</i> specified in Section III, Evaluation and Qualification Criteria, Sub-Factor 2.1.			
<input type="checkbox"/> Contract(s) not performed since 1 <sup>st</sup> January <i>[insert year]</i> specified in Section III, Evaluation and Qualification Criteria, requirement 2.1			
Year	Non-performed portion of contract	Contract Identification	Total Contract Amount (current value, currency, exchange rate and INR equivalent)
<i>[insert year]</i>	<i>[insert amount and percentage]</i>	Contract Identification: <i>[indicate complete contract name/ number, and any other identification]</i> Name of Employer: <i>[insert full name]</i> Address of Employer: <i>[insert street/city/country]</i> Reason(s) for non-performance: <i>[indicate main reason(s)]</i>	<i>[insert amount]</i>
Pending Litigation, in accordance with Section III, Evaluation and Qualification Criteria			
<input type="checkbox"/> No pending litigation in accordance with Section III, Evaluation and Qualification Criteria, Sub-Factor 2.3.			
<input type="checkbox"/> Pending litigation in accordance with Section III, Evaluation and Qualification Criteria, Sub-Factor 2.3 as indicated below.			

<b>Year of dispute</b>	<b>Amount of dispute (currency) in</b>	<b>Contract Identification</b>	<b>Total Contract Amount (currency), INR Equivalent (exchange rate)</b>
		Contract Identification: _____ Name of Employer: _____ Address of Employer: _____ Matter in dispute: _____ Party who initiated the dispute: _____ Status of dispute: _____	
		Contract Identification: Name of Employer: Address of Employer: Matter in dispute: Party who initiated the dispute: Status of dispute:	
<b>Litigation History in accordance with Section III, Evaluation and Qualification Criteria</b>			
<input type="checkbox"/> No Litigation History in accordance with Section III, Evaluation and Qualification Criteria, Sub-Factor 2.4.			
<input type="checkbox"/> Litigation History in accordance with Section III, Evaluation and Qualification Criteria, Sub-Factor 2.4 as indicated below.			
<b>Year of award</b>	<b>Outcome as percentage of Net Worth</b>	<b>Contract Identification</b>	<b>Total Contract Amount (currency), INR Equivalent (exchange rate)</b>
<i>[insert year]</i>	<i>[insert percentage]</i>	Contract Identification: <i>[indicate complete contract name, number, and any other identification]</i> Name of Employer: <i>[insert full name]</i> Address of Employer: <i>[insert street/city/country]</i> Matter in dispute: <i>[indicate main issues in dispute]</i> Party who initiated the dispute: <i>[indicate "Employer" or "Contractor"]</i> Reason(s) for Litigation and award decision <i>[indicate main reason(s)]</i>	<i>[insert amount]</i>

## Form FIN – 3.1 Financial Situation and Performance

Bidder's Name: \_\_\_\_\_  
 Date: \_\_\_\_\_  
 JV Member's Name \_\_\_\_\_  
 RFB No. and title: \_\_\_\_\_  
 Page \_\_\_\_\_ of \_\_\_\_\_ pages

### 1. Financial data<sup>#</sup>

Type of Financial information in (currency)	Historic information for previous _____ years, (amount in currency, currency, exchange rate*, in INR equivalent)				
	Year 1	Year 2	Year 3	Year 4	Year 5
Statement of Financial Position (Information from Balance Sheet)					
Total Assets (TA)					
Total Liabilities (TL)					
Total Equity/Net Worth (NW)					
Current Assets (CA)					
Current Liabilities (CL)					
Working Capital (WC)					
Information from Income Statement					
Total Revenue (TR)					
Profits Before Taxes (PBT)					
Cash Flow Information					
Cash Flow from Operating Activities					

\*Refer to ITB 15 for the exchange rate

# The Financial Certificate shall be certified by the Chartered Accountant.

## Form FIN - 3.2:

### Average Annual Turnover

(See Section III, Evaluation and Qualification Criteria, Sub-Factor 3.2)

Bidder's Name: \_\_\_\_\_  
Date: \_\_\_\_\_

S. No.	Financial Year	Annual Construction Turnover (INR Crore)
1	Financial Year 2014-15	
2	Financial Year 2015-16	
3	Financial Year 2016-17	

Note: The audited Financial Statements for the corresponding year has to be attached.

Name of the auditor issuing the certificate

Name of the auditor's Firm:

Seal of the auditor's Firm:

Date:

(Signature, name and designation of the authorised signatory for the Auditor's Firm)

\* See Section III, Evaluation and Qualification Criteria, Sub-Factor 3.2.

### **Form FIN – 3.3**

#### **Financial Resources**

Specify proposed sources of financing, such as liquid assets, unencumbered real assets, lines of credit, and other financial means, net of current commitments, available to meet the total construction cash flow demands of the subject contract or contracts as specified in Section III (Evaluation and Qualification Criteria)

<b>Financial Resources</b>		
<b>No.</b>	<b>Source of financing</b>	<b>Amount (INR equivalent)</b>
1		
2		
3		

## Form FIN – 3.4 Current Contract Commitments / Works in Progress

Bidders and each member to a JV should provide information on their current commitments on all contracts that have been awarded, or for which a letter of intent or acceptance has been received, or for contracts approaching completion, but for which an unqualified, full completion certificate has yet to be issued.

<b>Current Contract Commitments</b>					
<b>No.</b>	<b>Name of Contract</b>	<b>Employer's Contact Address, Tel, Fax</b>	<b>Value of Outstanding Work [Current INR Equivalent]</b>	<b>Estimated Completion Date</b>	<b>Average Monthly Invoicing Over Last Six Months [INR month]</b>
1					
2					
3					
4					
5					

## Form EXP - 4.1 General Construction Experience

Bidder's Name: \_\_\_\_\_  
 Date: \_\_\_\_\_  
 JV Member's Name \_\_\_\_\_  
 RFB No. and title: \_\_\_\_\_  
 Page \_\_\_\_\_ of \_\_\_\_\_ pages

Starting Year	Ending Year	Contract Identification	Role of Bidder
		Contract name: _____ Brief Description of the Works performed by the Bidder: _____ Amount of contract: _____ Name of Employer: _____ Address: _____	
		Contract name: _____ Brief Description of the Works performed by the Bidder: _____ Amount of contract: _____ Name of Employer: _____ Address: _____	
		Contract name: _____ Brief Description of the Works performed by the Bidder: _____ Amount of contract: _____ Name of Employer: _____ Address: _____	

## Form EXP - 4.2(a) Specific Construction and Contract Management Experience

Bidder's Name: \_\_\_\_\_  
 Date: \_\_\_\_\_  
 JV Member's Name \_\_\_\_\_  
 RFB No. and title: \_\_\_\_\_  
 Page \_\_\_\_\_ of \_\_\_\_\_ pages

Similar Contract No.	Information			
Contract Identification				
Award date				
Completion date				
Role in Contract	Prime Contractor <input type="checkbox"/>	Member JV <input type="checkbox"/>	in Management Contractor <input type="checkbox"/>	Sub-contractor <input type="checkbox"/>
Total Contract Amount			INR	
If member in a JV or sub-contractor, specify participation in total Contract amount				
Employer's Name:				
Address:				
Telephone/fax number				
E-mail:				



**Form EXP - 4.2(a) (cont.)**  
**Specific Construction and Contract Management Experience**  
**(cont.)**

Similar Contract No.	Information
Description of the similarity in accordance with Sub-Factor 4.2(a) of Section III:	
1. Amount	
2. Physical size of required works items	
3. Complexity	
4. Methods/Technology	
5. Construction rate for key activities	
6. Other Characteristics	

## Letter of Bid - Financial Part

**Date of this Bid submission:** *[insert date (as day, month and year) of Bid submission]*

**Request for Bid No.:** *[insert identification]*

To:

*Chief Executive Officer  
Nagar Nigam Aligarh  
Sewa Bhawan, Near Ghanta Ghar  
Church Compound, Civil Lines, Lal Diggi Road,  
Aligarh, Uttar Pradesh 202001, India  
PIN Code: 202001, Telephone: 0571-2401807, 2405520*

We, the undersigned, hereby submit the second part of our Bid, the Bid Price and Bill of Quantities. This accompanies the Letter of Technical Part.

In submitting our Bid, we make the following additional declarations:

- (a) **Bid Validity Period:** Our Bid shall be valid for a period specified in BDS 18.1 (or as amended if applicable) from the date fixed for the Bid submission deadline specified in BDS 22.1 (or as amended if applicable), and it shall remain binding upon us and may be accepted at any time before the expiration of that period;
- (b) **Commissions, gratuities and fees:** We have paid, or will pay the following commissions, gratuities, or fees with respect to the Bidding process or execution of the Contract: *[insert complete name of each Recipient, its full address, the reason for which each commission or gratuity was paid and the amount and currency of each such commission or gratuity].*

Name of Recipient	Address	Reason	Amount

(If none has been paid or is to be paid, indicate “none.”)

**Name of the Bidder:** *\*[insert complete name of person signing the Bid]*

**Name of the person duly authorized to sign the Bid on behalf of the Bidder:** *\*\* [insert complete name of person duly authorized to sign the Bid]*

**Title of the person signing the Bid:** *[insert complete title of the person signing the Bid]*

**Signature of the person named above:** *[insert signature of person whose name and capacity are shown above]*

**Date signed** *[insert date of signing]* **day of** *[insert month]*, *[insert year]*

\*: In the case of the Bid submitted by a Joint Venture specify the name of the Joint Venture as Bidder.

\*\* : Person signing the Bid shall have the power of attorney given by the Bidder. The power of attorney shall be attached with the Bid Schedules

**JOINT BIDDING AGREEMENT FOR CONSORTIUM/JOINT VENTURE**  
**[To be executed on Stamp paper of appropriate value]**

THIS JOINT BIDDING AGREEMENT is entered into on this the ..... day of ..... 20...

BETWEEN

1. ...., a company having its registered office at ..... (hereinafter referred to as the **“First Part”** which expression shall, unless repugnant to the context include its successors and permitted assigns)

**AND**

2. ...., a company having its registered office at ..... (hereinafter referred to as the **“Second Part”** which expression shall, unless repugnant to the context include its successors and permitted assigns).

The above mentioned parties of the FIRST and SECOND are collectively referred to as the **“Parties”** and each is individually referred to as a **“Party”**

**WHEREAS,**

A. **Ludhiana Smart City Limited, represented by its Chief Executive Officer and having its offices at Nagar Nigam Aligarh, Sewa Bhawan, Near Ghanta Ghar, Civil Lines, Lal Diggi Road, Aligarh, Uttar Pradesh 202001, India, (hereinafter referred to as the “Employer” which expression shall, unless repugnant to the context or meaning thereof, include its administrators, successors and assigns) has invited applications (the Applications”) by its Request for Bids No. .... dated ..... (the “RFB”) for selection of Bidders for construction of the ..... works (the “Works”) through Design, Procurement, Build, Operate and Commission and Transfer Contract.**

B. The Parties are interested in jointly Bidding for the Works as members of a JVA and in accordance with the terms and conditions of the RFB document and other Bid documents in respect of the Works, and

C. It is a necessary condition under the RFB document that the members of the JVA shall enter into a Joint Bidding Agreement and furnish a copy thereof with the Application.

a. NOW IT IS HEREBY AGREED as follows:

**1. Definitions and Interpretations**

In this Agreement, the capitalized terms shall, unless the context otherwise requires, have the meaning ascribed thereto under the RFB.

**2. JVA**

2.1 The Parties do hereby irrevocably constitute a consortium/joint venture (the “JVA”) for the purposes of jointly participating in the Bidding Process for the Works. The Parties confirm that all JVA members shall sign the Contract Agreement.

2.2 The Parties hereby undertake to participate in the Bidding Process only through this JVA and not individually and/ or through any other consortium constituted for this Works, either directly or indirectly or through any of their associates.

**3. Covenants**

The Parties hereby undertake that in the event the JVA is declared the selected Bidder and awarded the Contract, the JVA members shall enter into a Contract Agreement with the Employer and, through its lead partner, undertake to perform all its obligations in compliance with the Contract Agreement for the Works.

#### 4. Role of the Parties

The Parties hereby undertake to perform the roles and responsibilities as described below:

- a. Party of the First Part shall be the Lead member of the JVA and shall have the power of attorney from all Parties for conducting all business for and on behalf of the JVA during the Tendering Process and until the Contract Agreement is entered into with the Employer; Party of the First Part shall be the responsible for ..... and
- b. Party of the Second Part shall be the responsible for .....

#### 5. Joint and Several Liabilities

The Parties do hereby undertake to be jointly and severally responsible for all obligations and liabilities relating to the Works and in accordance with the terms of the RFB, Bidding Document and the Contract Agreement.

#### 6. Percentage Participation in the JVA

- 6.1 The Parties agree that the proportion of percentage participation in works among the Parties in the JVA shall be as follows: First Party (Lead Member): [should have at-least 51% percentage participation] Second Party: [should have at least 26% percentage participation]
- 6.2 The Parties undertake that they shall collectively hold 100% (hundred per cent) of the percentage participation of the JVA at all times until the Completion of the Project.

#### 7. Representation of the Parties

Each Party represents to the other Parties as of the date of this Agreement that:

- a) Such Party is duly organized, validly existing and in good standing under the laws of its incorporation and has all requisite power and authority to enter into this Agreement;
- b) The execution, delivery and performance by such Party of this Agreement has been authorized by all necessary and appropriate corporate or governmental action and a copy of the extract of the charter documents and board resolution/ power of attorney in favour of the person executing this Agreement for the delegation of power and authority to execute this Agreement on behalf of the JVA Member is annexed to this Agreement, and will not, to the best of its knowledge:
  - i. require any consent or approval not already obtained;
  - ii. violate any Applicable Law presently in effect and having applicability to it;
  - iii. violate the memorandum and articles of association, by-laws or other applicable organizational documents thereof;
  - iv. violate any clearance, permit, concession, grant, license or other governmental authorization, approval, judgment, order or decree or any mortgage agreement, indenture or any other instrument to which such Party is a party or by which such Party or any of its properties or assets are bound or that is otherwise applicable to such Party; or

- v. create or impose any liens, mortgages, pledges, claims, security interests, charges or encumbrances or obligations to create a lien, charge, pledge, security interest, encumbrances or mortgage in or on the property of such Party, except for encumbrances that would not, individually or in the aggregate, have a material adverse effect on the financial condition or prospects or business of such Party so as to prevent such Party from fulfilling its obligations under this Agreement;
- c) this Agreement is the legal and binding obligation of such Party, enforceable in accordance with its terms against it; and
- d) there is no litigation pending or, to the best of such Party's knowledge, threatened to which it or any of its associates is a party that presently affects or which would have a material adverse effect on the financial condition or prospects or business of such Party in the fulfillment of its obligations under this Agreement.

## 8. Termination

This Agreement shall be effective from the date hereof and shall continue in full force and effect until the Defects Liability Period (DLP) of the Works is achieved under and in accordance with the Contract Agreement, in case the Contract is awarded to the JVA. However, in case the JVA is either does not get selected for award of the Contract, the Agreement will stand terminated in case the Applicant is not pre-qualified or upon return of the Bid Security by the Employer to the Bidder, as the case may be.

## 9. Miscellaneous

9.1 This Joint Bidding Agreement shall be governed by laws of India. 9.2 The Parties acknowledge and accept that this Agreement shall not be amended by the Parties without the prior written consent of the Employer.

IN WITNESS WHEREOF THE PARTIES ABOVE NAMED HAVE EXECUTED AND DELIVERED THIS AGREEMENT AS OF THE DATE FIRST ABOVE WRITTEN.

SIGNED, SEALED AND  
DELIVERED

SIGNED, SEALED AND  
DELIVERED

For and on behalf of

LEAD MEMBER by:

SECOND PART

(Signature)  
(Name)  
(Designation)  
(Address)

(Signature)  
(Name)  
(Designation)  
(Address)

**In the presence of:**

1. \_\_\_\_\_
2. \_\_\_\_\_

Notes:

1. The mode of the execution of the Joint Bidding Agreement should be in accordance with the procedure, if any, laid down by the Applicable Law and the charter documents of the executant(s) and when it is so required, the same should be under common seal affixed in accordance with the required procedure.
2. Each Joint Bidding Agreement should attach a copy of the extract of the charter documents and documents such as resolution / power of attorney in favour of the person executing this Agreement for the delegation of power and authority to execute this Agreement on behalf of the Consortium Member.
3. For a Joint Bidding Agreement executed and issued overseas, the document shall be legalised by the Indian Embassy and notarized in the jurisdiction where the Power of Attorney has been executed. However, the Power of Attorney provided by Applicants from countries that have signed the Hague Legislation Convention 1961 are not required to be legalised by the Indian Embassy if it carries a conforming Apostille certificate.

## **PAYMENT SCHEDULE/SCHEDULE OF PRICES**

**Name of the Project:** Design, Manufacture, Supply, Installation and Commissioning of Different Capacity Roof Top Solar PV Power Projects under Net Metering Policy in Aligarh City (Smart City Mission)

### **PREAMBLE**

1. The parameters given by Employer are only as a guideline. Contractor shall carryout his own survey, investigation and design the system as per requirements as specified in the bid document and whatever else is necessary for successful completion of the works. The system should be designed in such a way that it meets all Architectural, Urban Planning, Engineering requirements of project, including Performance Criteria as Specified, functional requirements, feasibility requirements. The quoted bid price is deemed to be covered with all activities those are required to complete the work as per the conditions of contract, scope of work and technical specifications and as per RFB, even if such items are not included in the given schedule.
2. Tender drawings given in the bid document are indicative. Contractor shall submit his own detailed design and drawings including all GA drawings, Civil / Electrical / Mechanical / Instrumentation / Structural drawings, detailed construction drawings etc. as per specification and works requirement. The designs and drawings shall be approved from Engineer in Charge before executing the work.
3. Contractor has to get familiar with site conditions such as location, approach, availability of water, power, nearby features such as canal, Roads, Highways, Residential areas and plots, accessibility, weather conditions, including flood levels, flood conditions, high flood level, labour conditions, bye laws and local rules, safety rules and regulations, labour hire policy and insurance policies etc. prior to quoting. No extra claim will be entertained to Contractor for ignorance of site conditions as mentioned above or any other such conditions.
4. ***The overall contract price shall be inclusive of royalties, Goods and Service Tax (GST) and other applicable duties/taxes, if any.***
5. The bidder shall quote price for the total work of design, engineering, supply, construction, erection, testing and commissioning along with defect liability period as mentioned in RFB.

*Schedules  
Bill of Quantities  
(to be downloaded from <https://etender.up.nic.in>)*



## **Section V - Eligible Countries**

### **Eligibility of Procurement for the Provision of Goods, Works and Non-consulting Services in the projects financed by Government of India and/or State Government of Uttar Pradesh**

In reference to ITB 4.8 and ITB 5.1, the bidders are requested to check the eligibilities of the countries for procurement of goods, works and Non-consulting Services whether declared prohibited/ ineligible/ debarred/ blacklisted for trade and/or procurement by the Government of India (GoI)/ Government of Uttar Pradesh. During the Contract agreement, if at any time GoI declares the prohibition of trade/procurement of goods, works, Non-consulting services from country/countries, the same shall be applicable w.e.f. the date of enforcement declared by the Government of India

## Section VI - Fraud and Corruption

- 6.1 The Bidders and their respective officers, employees, agents and advisers shall observe the highest standard of ethics during the Bidding Process and subsequent to the issue of the Letter of Acceptance and/or Letter of Award and during the subsistence of the Contract Agreement. Notwithstanding anything to the contrary contained herein, or in the Letter of Acceptance and/or Letter of Award or the Contract Agreement, the Employer shall reject a Bid, withdraw the Letter of Acceptance and/or Letter of Award, or terminate the Contract Agreement, as the case may be, without being liable in any manner whatsoever to the Bidder or Contractor or Concessionaire, as the case may be, if it determines that the Bidder or Contractor or Concessionaire, as the case may be, has, directly or indirectly or through an agent, engaged in corrupt practice, fraudulent practice, coercive practice, undesirable practice or restrictive practice in the Bidding Process. In such an event, the Employer shall forfeit and appropriate the Bid Security or Performance Security, as the case may be, as mutually agreed genuine pre-estimated compensation and damages payable to the Employer towards, inter alia, time, cost and effort of the Employer, without prejudice to any other right or remedy that may be available to the Employer hereunder or otherwise.
- 6.2 Without prejudice to the rights of the Employer under Clause 6.1 hereinabove and the rights and remedies which the Employer may have under the Letter of Acceptance and/or Letter of Award or the Contract Agreement, if a Bidder or contractor or Concessionaire, as the case may be, is found by the Employer to have directly or indirectly or through an agent, engaged or indulged in any corrupt practice, fraudulent practice, coercive practice, undesirable practice or restrictive practice during the Bidding Process, or after the issue of the Letter of Acceptance and/or Letter of Award or the Contract Agreement or the execution of the Contract Agreement, such Bidder or Contractor or Concessionaire shall not be eligible to participate in any tender or RFB issued by the Employer during a period of 3 (three) years from the date such Bidder or Contractor or Concessionaire, as the case may be, is found by the Employer to have directly or indirectly or through an agent, engaged or indulged in any corrupt practice, fraudulent practice, coercive practice, undesirable practice or restrictive practices, as the case may be.
- 6.3 For the purposes of this Clause 6, the following terms shall have the meaning hereinafter respectively assigned to them:
- (a) “corrupt practice” means (i) the offering, giving, receiving, or soliciting, directly or indirectly, of anything of value to influence the actions of any person connected with the Bidding Process (for avoidance of doubt, offering of employment to or employing or engaging in any manner whatsoever, directly or indirectly, any official of the Employer who is or has been associated in any manner, directly or indirectly with the Bidding Process or the Letter of Acceptance and/or Letter of Award or has dealt with matters concerning the Contract Agreement or arising therefrom, before or after the execution thereof, at any time prior to the expiry of one year from the date such official resigns or retires from or otherwise ceases to be in the service of the Employer, shall be deemed to constitute influencing the actions of a person connected with the Bidding Process); or (ii) engaging in any manner whatsoever, whether during the Bidding Process or after the issue of the Letter of Acceptance and/or Letter of Award or after the execution of the Contract

Agreement, as the case may be, any person in respect of any matter relating to the Project or the Letter of Acceptance and/or Letter of Award or the Contract Agreement, who at any time has been or is a legal, financial or technical adviser of the Employer in relation to any matter concerning the Project;

- (b) “fraudulent practice” means a misrepresentation or omission of facts or suppression of facts or disclosure of incomplete facts, in order to influence the Bidding Process ;
- (c) “coercive practice” means impairing or harming, or threatening to impair or harm, directly or indirectly, any person or property to influence any person’s participation or action in the Bidding Process;
- (d) “undesirable practice” means (i) establishing contact with any person connected with or employed or engaged by the Employer with the objective of canvassing, lobbying or in any manner influencing or attempting to influence the Bidding Process; or (ii) having a Conflict of Interest; and
- (e) “Restrictive practice” means forming a cartel or arriving at any understanding or arrangement among Bidders with the objective of restricting or manipulating a full and fair competition in the Bidding Process.

## **PART 2 –Works’ Requirements**

## **Section VII - Works' Requirements**

### **Table of Contents**

**Chapter 1- Introduction. ....**

**Chapter 2- Scope of Work .....**

**Chapter 3- Specifications and Standards .....**

**Chapter 4: Indicative Concept design drawings .....**

## Chapter 1- Introduction

### Introduction

- 1.1 In grid-connected solar photo-voltaic (PV) systems, solar energy is fed into the building loads that are connected to the grid through a service connection with surplus energy being fed into the grid and shortfall being drawn from the grid. Production of surplus energy may happen when solar energy produced exceeds the energy consumption of the building. This surplus is fed into the grid. During the night, or when during the day energy demand in the building exceeds solar energy generation, energy is drawn from the grid. Grid-connected solar PV systems have no battery storage and will not work during grid outage. For buildings with grid-connected solar PV systems, the service connection meter needs to be of the bidirectional type, whereby import kWh and export kWh are separately recorded.
- 1.2 A grid-connected solar PV system consists of the solar panels, solar panels mounting structure, one or more solar grid inverters, protection devices, meters, interconnection cables and switches.
- 1.3 Components and parts used in solar PV systems should conform to the BIS or IEC or other international specifications, wherever such specifications are available and applicable.

### 2.0 Quality and Workmanship

Solar PV modules are designed to last 25 years or more. It is therefore essential that all system components and parts, including the mounting structures, cables, junction boxes, distribution boxes and other parts also have a life cycle of at least 25 years. Therefore all works shall be undertaken with the highest levels of quality and workmanship. During inspection special attention will be given to neatness of work execution and conformity with quality and safety norms. Non-compliant works will have to be redone at the cost of the Installer.

### 3.0 System Sizing

As per the solar net metering orders of the Uttar Pradesh, crediting of energy for the purpose of net-metering is limited to the maximum peak capacity of the grid connected rooftop solar PV system to be installed by any eligible consumer shall not exceed 100% of the sanctioned connected load / contract demand of the consumer.

## Chapter 2- Scope of Work

### Scope of Work

- Site survey and Layout planning
- Design, development and supply of all components of the SPV power system
- Transportation of SPV Power system up to a project location
- Installation and commissioning of SPV Power system up to AC distribution board along with Net-metering including supply of bi-directional meters with necessary arrangement for integration grid and protection during absence of grid supply.
- Integration of power supplied to the grid from Gandhi Park location. The power transferred to the grid is to be designed enabling it to be used for the Electrical consumption for the facilities at Gandhi Park.
- Training of the staff
- Maintenance (CMC) during warranty period of 5 years

### Scope of Supply:

The SPV power plants should be supplied & installed by the companies as per specifications given in the document which comply with the latest guidelines of UPERC, UPNEDA, UPPCL, MNRE, and GoI. Following parts for each SPV projects are mainly required to be supplied:

- SPV Module of capacity ranging from 100Wp and above
- Power conditioning Unit (PCU) 1KW and above
- PVC insulated Copper cables as per BIS Codes for AC & DC inter connections.
- Junction Boxes with surge arrestors and MCB.
- Structure for solar PV project, MS Galvanized / Aluminium.
- O&M manual and warranty card in English Language
- **3.5c x185 sq mm 1100V PVC armoured aluminium cable as per IS 1554 ( part - 1) -30meter with system and if any more PVC cable required shall be supplied as per unit rate specified in price bid.**

Any other part as per site requirement.

### WARRANTY

- The Solar power projects including the battery shall be warranted for five years after the date of commissioning of the project for replacement in case of any manufacturing, operation failure, non-performance as per design standards.
- The PV module(s) shall be warranted for a minimum period of 25 years from the date of commissioning of the project. The PV modules must be warranted for their output peak watt capacity, which should not be less than 90% at the end of Ten (10) years and 80% at the end of twenty five (25) years

- The Warranty Card to be supplied with the system must contain the details of the system.

**Maintenance during Warrantee period of five years:**

- a. Schedule visit of the supplier's engineer to the site on quarterly basis for maintenance/ assessing the maintenance requirements.
- b. Visit to the site on call basis to provide maintenance services within three days of lodging of complaint.
- c. Corrective & remedial maintenance services to set right the malfunction of the SPV- projects include supply and replacement of all damaged parts/ components including electronics/ charge controller, Inter connected cables/ parts and fuse etc. with new parts.

**OPERATION & MAINTENANCE MANUAL**

An Operation, Instruction and Maintenance Manual, in English & Hindi Languages should be provided with the Solar PV projects. The following minimum details must be provided in the Manual:

- Basic principles of Photovoltaic.
- A small write-up (with a block diagram) on the Solar PV project - its components, PV module, battery, electronics and luminary and expected performance shall be provided.
- Type, Model number, Voltage & capacity of the battery, used in the system.
- The make, model number, country of origin and technical characteristics of all the component are required to be provided.
- Clear instructions on regular maintenance and troubleshooting of the Solar PV Projects.
- DO's and DONT's.
- Name and address of the contact person for repair and maintenance, in case of non-functionality of the SPV Projects.



## Chapter 3- Specifications and Standards

### GENERAL TECHNICAL SPECIFICATIONS-

**The General Technical Specifications must comply to the Govt of India regulations/standards and in addition to comply to with Net Metering Policy and Regulations of UPERC.**

#### A. SPV MODULES :

- ***Indigenously manufactured PV modules should be used.***
- The PV module should have crystalline silicon solar cells and must have a certificate of testing conforming to IEC 61215 Edition II / BIS 14286 from an NABL or IECQ accredited Laboratory.
- The power output of the module(s) under STC should be a minimum of 100 Wp at a load voltage\* of  $16.4 \pm 0.2$  V. Vnom 12V.
- The open circuit voltage\* of the PV modules under STC should be at least 21.0 Volts.
- The module efficiency should not be less than 14 %.
- The terminal box on the module should have provision for opening to replace the cable, if required.
- PV modules must be warranted for their output peak watt capacity which should not be less than 90 % at the end of 10 years and 80% at the end of 25 years.

#### B. IDENTIFICATION AND TRACEABILITY

Each PV module used in any solar power project must use a RF identification tag. The following information must be mentioned in the RFID used on each module

(This should be inside the laminate and must be able to withstand harsh environmental conditions.)

- Name of the Manufacturer of PV module
- Name of the manufacturer of Solar Cells.
- Month and year of the manufacture (separately for solar cells and module).
- Country of origin (separately for solar cells and module).
- I-V curve for the module.
- Peak wattage, Im, Vm and FF for the module.
- Unique serial no and model no of the module.
- Date and year of obtaining IEC PV module qualification certificate.
- Name of test lab issuing IEC certificate
- Other relevant information on traceability of solar cells and module as per
- ISO 9000 series.

#### C. BALANCE OF SYSTEM (BOS):

- Cables should confirm to applicable standards i.e. IEC 60189, IS 694/ IS1554, IS/IEC 69947.
- Switches / Circuit Breakers / Connector should confirm to IS/IEC 60947 part I,II,III,EN 0521 standards

- Junction Boxes should confirm to IP 65 for outdoor / IP 21 for indoor use and IEC 62208 standards.
- SPV system design should confirm to IEC 62124 standards
- Installation of systems should confirm to IEC 60364-7-712 standards

**D. POWER CONDITIONING UNIT (PCU)**

The PCU should convert DC power produced by SPV modules, in to AC power and adjust the voltage & frequency levels to suit the local grid conditions. The inverter shall interconnect and feed power to the LT power supply of the building and also shall have the provision to power critical loads.

Common Technical Specification:

- Control Type : Voltage source, microprocessor assisted, output regulation
- Output voltage : Single Phase, 230 V ac (+12.5 %, - 20 % V ac)
- : 3 phase, 415 V ac (+12.5 %, - 20 % V ac)
- Frequency : 50 Hz (+3 Hz, -3 Hz)
- Total Harmonic Distortion : less than 3%
- Operating temperature Range : 0 to 55 deg C

**E. INVERTER STANDARDS :**

Inverter should comply with IEC 61683/IS 61683 for efficiency and Measurements and should comply IEC 60068-2 (1, 2, 14, 30) / Equivalent BIS Standard for environmental testing. Inverter should supervise the grid condition continuously and in the event of grid failure (or) under voltage (or) over voltage, Solar System should be disconnected by the circuit Breaker / Auto switch provided in the inverter.

Power Control: MPPT

Other important Features/Protections required in the INVERTER

- Automatic morning wake-up and nightly shutdown
- Mains (Grid) over-under voltage and frequency protection
- Fool proof protection against ISLANDING.
- Included authentic tracking of the solar array’s maximum power operation voltage (MPPT).
- Array ground fault detection.
- LCD and piezoelectric keypad operator interface Menu driven
- Automatic fault conditions reset for all parameters like voltage, frequency and/or black out.

- Surge arresters on AC and DC terminals for over voltage protection from lightning-induced surges.
- INVERTER should be rated to operate at 0 –55 deg. Centigrade unless provision for air conditioning is included in INVERTER
- All parameters should be accessible through an industry standard communication link.
- Overload capacity (for 10 sec) should be 150 % of continuous rating

**F. HARMONICS STANDARD :**

As per the standard of IEEE 519, the permissible individual harmonics level shall be less than 3% (for both voltage and current harmonics) and Total

Harmonics Distortion (THD) for both voltage and current harmonics of the system shall be less than 5%.

**Technical and interconnection requirements**

<b>Overall conditions of Service</b>	State Distribution/Supply Code	State Distribution/Supply Code
<b>Overall Grid Standards</b>	Central Electricity Authority (Grid Standard) Regulations 2010	Central Electricity Authority (Grid Standard) Regulations 2010
<b>Equipment</b>	BIS / IEC / IEEE	BIS / IEC / IEEE
<b>Meters</b>	Central Electricity authority (Installation & operation of meters) Regulation 2006 as amended time to time	Central Electricity authority (Installation & operation of meters) Regulation 2006 as amended time to time
<b>Safety and supply</b>	Central Electricity Authority(measures of safety and electricity supply) Regulations, 2010	Central Electricity Authority(measures of safety and electricity supply) Regulations, 2010
<b>Harmonic Requirement Harmonic Current</b>	IEEE 519 CEA (Technical Standards for Connectivity of the Distributed Generation Resources) Regulations 2013	IEEE 519 CEA (Technical Standards for Connectivity of the Distributed Generation Resources) Regulations 2013
<b>Synchronization</b>	IEEE 519 CEA Connectivity of the Distributed Generation Resources) Regulations 2013	Photovoltaic system must frequency synchronization device. Every time the generating station is synchronized to the electricity system. It shall not cause voltage fluctuation greater than+/- 5% at point of connection.



<b>Voltage</b>	IEEE 519 CEA (Technical Standards for Connectivity of the Distributed Generation Resources) Regulations 2013	The voltage-operating window should minimize nuisance tripping and should be under operating range of 80% to 110% of the nominal connected voltage. Beyond a clearing time of 2 second, the photovoltaic system must isolate itself from the grid.
<b>Flicker</b>	IEEE-519 CEA(Technical Standards for Connectivity of the Distribution GenerationResources) Regultions 2013	Operation of Photovoltaic system should not cause voltage flicker in excess of the limits stated in IEC 61000 standards or other equivalent Indian standards, if any.
<b>Frequency</b>	IEEE 519 CEA (Technical Standards for Connectivity of the Distributed Generation Resources) Regulations 2013	When the Distribution system frequency deviates outside the specified conditions (50.5 Hz on upper side and 47.5 Hz on lower side), There should be over and under frequency trip functions with a clearing time of 0.2 seconds.
<b>DC injection</b>	IEEE 519 CEA (Technical Standards for Connectivity of the Distributed Generation Resources) Regulations 2013	Photovoltaic system should not inject DC power more than 0.5% of full rated output at the interconnection point or 1% of rated inverter output current into distribution system under any operating conditions.

<b>Power Factor</b>	IEEE 519 CEA (Technical Standards for Connectivity of the Distributed Generation Resources) Regulations 2013	While the output of the inverter is greater than 50%, a lagging power factor of greater than 0.9 should operate.
<b>Islanding and Disconnection</b>	IEEE 519 CEA (Technical Standards for Connectivity of the Distributed Generation Resources) Regulations 2013	The photovoltaic system in the event of fault, voltage or frequency variations must island/disconnect itself within IEC standard on stipulated period.
<b>Overload and Overheat</b>	IEEE 519 CEA (Technical Standards for Connectivity of the Distributed Generation Resources) Regulations 2013	The inverter should have the facility to automatically switch off in case of overload or overheating and should restart when normal conditions are restored.
<b>Paralleling Device</b>	IEEE 519 CEA (Technical Standards for Connectivity of the Distributed Generation Resources) Regulations 2013	Paralleling device of photovoltaic system shall be capable of withstanding 220% of the normal voltage at the interconnection point.

## G. ELECTRICAL SAFETY, EARTHING AND PROTECTION

- **Internal Faults:** In built protection for internal faults including excess temperature, commutation failure, overload and cooling fan failure (if fitted) is obligatory.
- **Galvanic Isolation:** Galvanic Isolation is required to avoid any DC component being injected into the grid and the potential for AC components appearing at the array.
- **Over Voltage Protection:** Over Voltage Protection against atmospheric lightning discharge to the PV array is required. Protection is to be provided against voltage fluctuations in the grid itself and internal faults in the power conditioner, operational errors and switching transients.
- **Earth fault supervision:** An integrated earth fault device shall have to be provided to detect eventual earth fault on DC side and shall send message to the supervisory system.
- **Cabling practice:** Cable connections must be made using PVC Cu cables, as per BIS standards. All cable connections must be made using suitable terminations for effective contact. The PVC Cu cables must be run in GL trays with covers for protection.
- **Fast acting semiconductor type current limiting fuses** at the main bus-bar to protect from the grid short circuit contribution.

- The INVERTER shall include an easily accessible emergency OFF button located at an appropriate position on the unit.
- The INVERTER shall include ground lugs for equipment and PV array grounding. The DC circuit ground shall be a solid single point ground connection in accordance with WEC 69042.
- All exposed surfaces of ferrous parts shall be thoroughly cleaned, primed, and painted or otherwise suitably protected to survive a nominal 30 years design life of the unit. The INVERTER enclosure shall be weatherproof and capable of surviving climatic changes and should keep the INVERTER intact under all conditions in the room where it will be housed. The INVERTER shall be located indoor and should be either wall/ pad mounted.
- Moisture condensation and entry of rodents and insects shall be prevented in the INVERTER enclosure.
- Components and circuit boards mounted inside the enclosures shall be clearly identified with appropriate permanent designations, which shall also serve to identify the items on the supplied drawings.
- All doors, covers, panels and cable exists shall be gasketed or otherwise designed to limit the entry of dust and moisture. All doors shall be equipped with locks. All openings shall be provided with grills or screens with openings no larger than 0.95 cm. (about 3x8 inch).
- In the design and fabrication of the INVERTER the site temperature (50 to 55O C), incident sunlight and the effect of ambient temperature on component life shall be considered carefully. Similar consideration shall be given to the heat sinking and thermal for blocking diodes and similar components.

**H. SOLAR PV MODULES MOUNTING STRUCTURE**

- 1.1 The PV modules shall be mounted on fixed metallic structures having adequate strength and appropriate design, which can withstand the load of the modules and high wind velocities. The support structure shall be hot dip galvanized steel or aluminum.
- 1.2 Detailed specifications for the mounting structure are given below:

Wind velocity withstanding capacity	150km/hour
Structure material	Hot dip Galvanized steel with minimum galvanization thickness of 120 microns or Aluminum alloy
Bolts , nuts, fasteners, panel mounting clamps	Stainless steel SS 304
Mounting arrangement for RCC flat roofs	With removable concrete ballast made of pre-fabricated PCC(1:2:4), M 15
Mounting arrangement for metal sheet roofs	Mounting directly on the sheet metal ensuring stability and wind withstanding capacity or penetrating the sheet metal and fixing to the sub-structure, ensuring that the roof remains water proof
Mounting arrangement for elevated structure	The elevated structure has to be surely anchored to the supporting surface concrete foundations of appropriate weight and depth for elevated

	structures mounted directly on the ground bolted with Anchor bolts of appropriate strength for elevated structure mounted on RCC structure
Mounting arrangement for ground installations	With removable concrete ballast made of pre-fabricated PCC (1:2:4), M 15 assuring enough ground clearance to prevent damage of the module through water, animals and other environmental factors
Installation	The structures shall be designed for simple mechanical on site installation. There shall be no requirement of welding or complex machinery at the installation site
Minimum distance between roof edge and mounting structure	0.6m
Access for panel cleaning and maintenance	All solar panels must be accessible from the top for cleaning and from the bottom for access to the module junction box
Panel tilt angle	North –south orientation with a fixed tilt angle of 11-13 degrees (depending on location) south facing.

1.3 The prospective Installer shall specify installation details of the solar PV modules and the support structures with lay-out drawings and array connection diagrams. The work shall be carried out as per the designs approved by the Customer.

**I. DATA ACQUISITION SYSTEM / PLANT MONITORING**

- i. Data Acquisition System shall be provided for each of the solar PV plant above 10 kWp capacity.
- ii. Data Logging Provision for plant control and monitoring, time and date stamped system data logs for analysis with the high quality, suitable PC. Metering and Instrumentation for display of systems parameters and status indication to be provided.
- iii. Solar Irradiance: An integrating Pyranometer / Solar cell based irradiation sensor (along with calibration certificate) provided, with the sensor mounted in the plane of the array. Readout integrated with data logging system.
- iv. Temperature: Temperature probes for recording the Solar panel temperature and/or ambient temperature to be provided complete with readouts integrated with the data logging system
- v. The following parameters are accessible via the operating interface display in real time separately for solar power plant:
  - a. AC Voltage.
  - b. AC Output current.
  - c. Output Power



- d. Power factor.
  - e. DC Input Voltage.
  - f. DC Input Current.
  - g. Time Active.
  - h. Time disabled.
  - i. Time Idle.
  - j. Power produced
  - k. Protective function limits (Viz.-AC Over voltage, AC Under voltage, over frequency, under frequency ground fault, PV starting voltage, PV stopping voltage.
- vi. All major parameters available on the digital bus and logging facility for energy auditing through the internal microprocessor and read on the digital front panel at any time) and logging facility (the current values, previous values for up to a month and the average values) should be made available for energy auditing through the internal microprocessor and should be read on the digital front panel.
  - vii. PV array energy production: Digital Energy Meters to log the actual value of AC/ DC voltage, Current & Energy generated by the PV system provided. Energy meter along with CT/PT should be of 0.5 accuracy class.
  - viii. Computerized DC String/Array monitoring and AC output monitoring shall be provided as part of the inverter and/or string/array combiner box or separately.
  - viii. String and array DC Voltage, Current and Power, Inverter AC output voltage and current (All 3 phases and lines), AC power (Active, Reactive and Apparent), Power Factor and AC energy (All 3 phases and cumulative) and frequency shall be monitored.
  - ix. Computerized AC energy monitoring shall be in addition to the digital AC energy meter.
  - x. The data shall be recorded in a common work sheet chronologically date wise. The data file shall be MS Excel compatible. The data shall be represented in both tabular and graphical form.
  - xi. All instantaneous data shall be shown on the computer screen.
  - xii. Software shall be provided for USB download and analysis of DC and AC parametric data for individual plant.
  - xiii. Provision for instantaneous Internet monitoring and download of historical data shall be also incorporated.
  - xiv. Remote Server and Software for centralized Internet monitoring system shall be also provided for download and analysis of cumulative data of all the plants and the data of the solar radiation and temperature monitoring system.
  - xv. Ambient / Solar PV module back surface temperature shall be also monitored on continuous basis.
  - xvi. Simultaneous monitoring of DC and AC electrical voltage, current, power, energy and other data of the plant for correlation with solar and environment data shall be provided.

- xvii. Remote Monitoring and data acquisition through Remote Monitoring System software at the owner with latest software/hardware configuration and service connectivity for online / real time data monitoring / control complete to be supplied and operation and maintenance / control to be ensured by the bidder.
- xviii. The bidders shall be obligated to push real-time plant monitoring data on a specified intervals (say 15 minute) through open protocol at receiver location (cloud server) in XML/JSON format, preferably. Suitable provision in this regard will be intimated to the bidders.

**J. INTEGRATION OF PV POWER WITH GRID:**

The output power from SPV would be fed to the inverters which converts DC produced by SPV array to AC and feeds it into the main electricity grid after synchronization. In case of grid failure, or low or high voltage, solar PV system shall be out of synchronization and shall be disconnected from the grid. Once the DG set comes into service, PV system shall again be synchronized with DG supply and load requirement would be met to the extent of availability of power. 4 pole isolation of inverter output with respect to the grid/ DG power connection need to be provided

**K. METER CONFIGURATION OPTIONS**

The metering system for rooftop solar system, under net-metering arrangement, shall be as elaborated below which should be applicable till such time the Central Electricity Authority notifies the standards in this matter.

The utility meter (Net-meter) has to be bi-directional meter to register both import grid electricity amount as well as export solar electricity amount.

Bidirectional energy meter with CTs and PT, if required, having the feature of recording both the import and export of energy, besides other parameters shall be as per CEA metering regulations or State Grid code as applicable and of the make & specifications as approved by DVVNL shall be installed at the point where interconnection is made between Consumer system and DVVNL system.

Details of Energy Meters are under.

SR NO	METER DESCRIPTION	ACCURACY	LOAD OF CONSUMER	VOLTAGE LEVEL
1	Single Phase 10-60 A, whole current	Class-I	Up to 7 KW	Single Phase LT 230 V
2	3 Phase 10-60 A, whole current	Class-I	More than 7KW & up to 25 KW	Three Phase LT 400 V
3	LT AC 3-Phase 4- Wires CT operated static DLMC compliant energy meter	Class- 0.5s or better	More than 25 KW & up to 100 KW	Three Phase LT 400 V

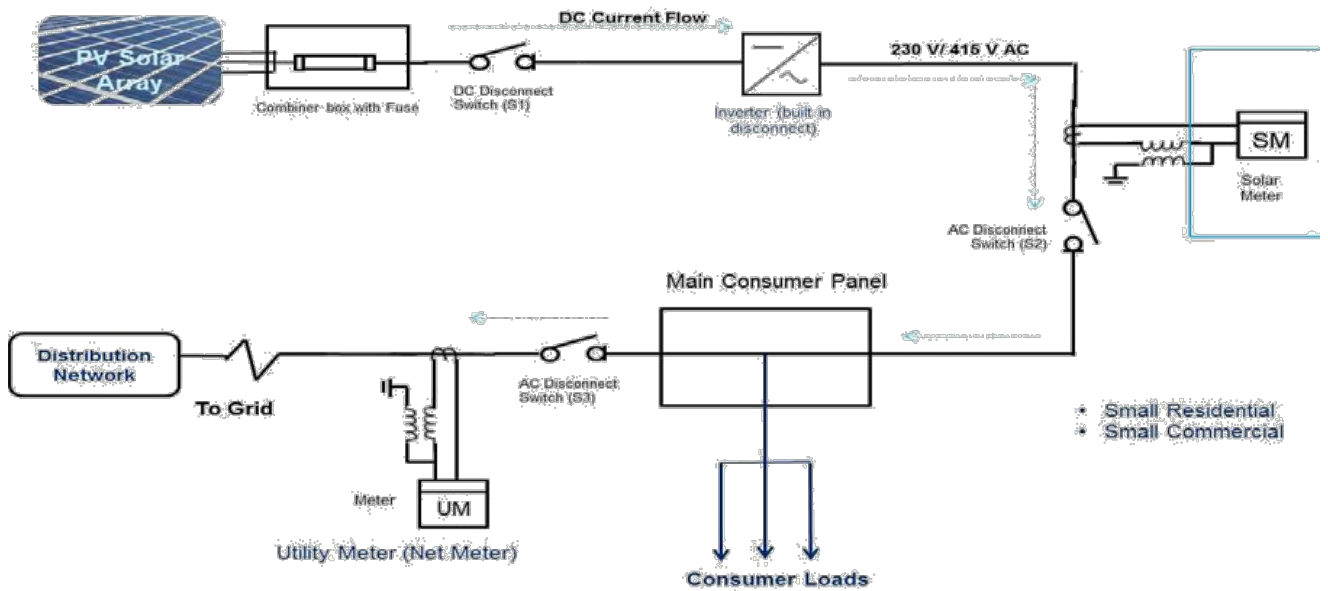

4	HT TPT Meter, DLMS Compliant & AMR Compatible	Class- 0.5s or better	More than 100 KW	Three Phase HT (11 KV)
---	---	-----------------------	------------------	------------------------

**Two Meter Configuration without Storage** The metering protocol for ‘Grid connected rooftop solar PV system without storage’ and location of solar meter and consumer meter shall be in accordance with the schematic below:-

**L. SPV PLANT AND METERING: -**

All the equipment associated with solar plant installation like solar PV panels, inverters; synchronizer, MPPT, batteries, transformers, cables, junction boxes etc shall be brand new and as per latest specified Indian/IEC standards. Bidirectional energy meter with CTs and PT, if required, having the feature of recording both the import and export of energy, besides other parameters shall be as per CEA metering regulations or State Grid code as applicable and of the make & specifications as approved by DVVNL shall be installed at the cost of the SPV plant owner at the point where interconnection is made between Consumer system and DVVNL system. The Plant owner has option to install the meter and metering equipment procured by DVVNL or can procure from vendors approved by DVVNL. If metering system is procured by Plant owner, then the testing and installation of meters including CTs and PT shall be got carried out from DVVNL as per the latest departmental instructions and no meter rentals shall be charged. DVVNL shall seal the tested bidirectional energy meters as per prevailing practice of DVVNL.

**M. CONNECTIVITY AND PROTECTION: -**

Solar Photo Voltaic rooftop systems shall be allowed in house auto synchronization or de synchronization facility with distribution system of the licensee at generation voltage level. It will utilize the same service line for excess power injection into the Grid which is currently being used by the consumer for drawl of power from utility network and shall operate in synchronization with DVVNL system provided that such injection of power from the rooftop solar PV system shall not be more than 90% of the total consumption from the licensee's supply by the consumer in a Settlement Period. It shall be mandatory for the solar rooftop generator to provide an appropriate protection system on their incoming side or consumer premises with the feature of "Islanding the SPV generator", so as to achieve isolation of consumer power-system from utility power-system during grid failure including protection from voltage / lightning surges. The Power Conditioning Unit of the SPV plant shall have features to filter out harmonics and other distortions before injecting the energy into DVVNL system

**N. OPERATION AND MAINTENANCE: -**

- (a) The solar plant shall comply with the relevant standards specified by the MNRE /BIS and CEA. The responsibility of operation and maintenance of the solar photo voltaic (SPV) generator including all accessories and apparatus lies with the consumer. The design and installation of the rooftop SPV should be equipped with appropriately rated protective devices to sense any abnormality in the system and carry out automatic isolation of the SPV from the grid. The inverters used should meet the necessary quality requirements and should be certified for their quality by appropriate authority; the protection logics should be tested before commissioning of the plant.
- (b) The automatic isolation or islanding protection of SPV should be ensured for, no grid supply and low or over voltage conditions and within the required response time. Adequate rated fuses and fast acting circuit breakers on input and output side of the inverters and disconnect/isolating switches to isolate DC and AC system for maintenance shall be provided. The consumer should provide for all internal safety and protective mechanism for earthing, surge, DC ground fault, transients etc.

- (c) To prevent back feeding and possible accidents when maintenance works are carried out by DISCOM personnel, Double pole/Triple pole with neutral isolating disconnect switches which can be locked by DISCOM personnel should be provided. This is in addition to automatic sensing and isolating on grid supply failure etc and in addition to internal disconnect switches. In the event of DISCOM LT/HT supply failure, the consumer has to ensure that there will not be any solar power being fed to the LT/HT grid of DISCOM. The consumer is solely responsible for any accident to human beings/animals whatsoever (fatal/non-fatal/departmental/non-departmental) that may occur due to back feeding from the SPV plant when the grid supply is off. DISCOM reserves the right to disconnect the installation at any time in the event of damage to its grid, meter, etc. or to prevent accident or damage
- (d) The consumer shall abide by all the codes and regulations issued by the Commission to the extent applicable and in force from time to time. The consumer shall comply with DISCOM/CEA requirements with respect to safe, secure and reliable function of the SPV plant and the grid. The power injected into the grid shall be of the required quality in respect of wave shape, frequency, absence of DC components etc.
- (e) The consumer shall restrict the harmonic generation within the limit specified in the agreement or specified by the Central Electricity Authority as and when such regulation is issued.
- (f) The SPG (individual homes/commercial establishments) may establish LT grid interactive solar power plant in the roof top or elevated surface with the following options: (i). Grid interactive solar PV system without battery. (ii). Grid interactive solar PV system with battery backup.

However, in both the options, features as per section clause (b) & (c) above shall be available so as to ensure islanding of the SPV system & prevent back feeding to Grid system of DVVNL.

- (g) The inverter standard shall be such that it should not allow solar power/battery power to extend to DISCOM's LT grid on failure of DISCOM's grid supply, irrespective of the LT connectivity options. The required inverter standard for three phase and single phase solar power are furnished in the document. (8) The inverter should be a sine wave inverter. Harmonic standards shall be as per IEEE 519. 2.13. Penalty or Compensation: - In case of failure of net metering system, the provisions of penalty or compensation shall be as per the provisions of the standard of performance regulations for distribution licensee.

## **O. INTERCONNECTION WITH THE GRID, STANDARDS & SAFETY**

The interconnection of the rooftop solar system with the network of the distribution licensee shall conform to the standards as provided in Central Electricity Authority (Technical Standard for Connectivity of the Distributed Generation Resources) Regulations, 2013 as amended from time to time. 8.2 The interconnection of the rooftop solar system with the distribution system of the licensee shall conform to the relevant

provisions of the Central Electricity Page 8 of 13 Authority (Measures relating to Safety and Electric Supply), Regulations, 2010, as amended from time to time. 8.3 The grid interactive rooftop solar system may be installed with or without battery backup. Provided that where the rooftop solar system is installed with battery backup (full load backup/partial load backup), the inverter shall have separate backup wiring to prevent the battery/decentralized generation power to flow into the grid in the absence of grid supply and manual isolation switch shall also be provided. 8.4 The consumer shall be responsible for safe operation, maintenance and rectification of any defect of the rooftop solar system up to the point of Net Meter beyond which the responsibility of safe operation, maintenance and rectification of any defect in the system, including the Net Meter, shall be that of the licensee. 8.5 The consumer shall provide appropriate protection for islanding of SPV system from the network of distribution licensee during grid/supply failure. 8.6 The licensee shall have the right to disconnect the rooftop solar system at any time in the event of possible threat/damage, from such rooftop solar system to its distribution system, to prevent any accident or damage, without any notice.



## Chapter 4: Proposed Locations

Sl. No.	Site	Proposed SPV plant Size (kWp)
1	Aligarh Development Authority	34
2	Collectorate meeting hall (District Minority Welfare office)	49
3	Nagar Nigam	28
4	Jila Vidyalaya Nirikshak karyalay	2
5	Circuit House	63
6	Gandhi Eye hospital	133
7	Head Post Office	32
8	Diwani Parisar	85
9	Treasury Office	36
10	CMO Office	20
11	Vikas Bhawan	67
12	Divisional Commissioner Office	34
13	38 <sup>th</sup> BN PAC , Aligarh	500
14	Gandhi Park	13
15	Rajkiya Kanya Inter College	5
16	Divisional Commissioner Residence	34
	<b>Total</b>	<b>1135</b>





## **PART 3 – Conditions of Contract and Contract Forms**



## **Section VIII - General Conditions of Contract**

## Table of Clauses

<b>A. General.....</b>	<b>100</b>
1. Definitions .....	100
2. Interpretation.....	102
3. Language and Law.....	103
4. Project Manager’s Decisions .....	103
5. Delegation.....	103
6. Communications .....	103
7. Subcontracting .....	103
8. Other Contractors.....	103
9. Personnel and Equipment .....	104
10. Employer’s and Contractor’s Risks .....	104
11. Employer’s Risks.....	104
12. Contractor’s Risks.....	105
13. Insurance.....	105
14. Site Data.....	105
15. Contractor to Construct the Works .....	105
16. The Works to Be Completed by the Intended Completion Date .....	106
17. Approval by the Project Manager.....	106
18. Safety .....	106
19. Discoveries.....	107
20. Possession of the Site.....	107
21. Access to the Site.....	107
22. Instructions, Inspections and Audits.....	107
23. Appointment of the Adjudicator .....	107
24. Procedure for Disputes.....	108
25. Fraud and Corruption.....	108
<b>B. Time Control.....</b>	<b>109</b>
26. Program.....	109
27. Extension of the Intended Completion Date.....	109
28. Acceleration .....	110
29. Delays Ordered by the Project Manager.....	110
30. Management Meetings.....	110
31. Early Warning.....	110
<b>C. Quality Control .....</b>	<b>110</b>
32. Identifying Defects .....	110
33. Tests.....	111
34. Correction of Defects & Operation and maintenance.....	112
35. Uncorrected Defects .....	112
<b>D. Cost Control.....</b>	<b>112</b>
36. Contract Price .....	112
37. Changes in the Contract Price.....	112
38. Variations.....	113
39. Cash Flow Forecasts .....	114

---

40.	Payment Certificates .....	115
41.	Payments .....	115
42.	Compensation Events .....	116
43.	Tax .....	117
44.	Currencies .....	118
45.	Price Adjustment.....	118
46.	Retention.....	118
47.	Liquidated Damages .....	119
48.	Bonus .....	119
49.	Advance Payment .....	119
50.	Securities.....	120
51.	Dayworks .....	121
52.	Cost of Repairs.....	121
<b>E.</b>	<b>Finishing the Contract .....</b>	<b>121</b>
53.	Completion.....	121
54.	Taking Over .....	121
55.	Final Account.....	121
56.	Operating and Maintenance Manuals .....	122
57.	Termination.....	122
58.	Payment upon Termination.....	123
59.	Property.....	123
60.	Release from Performance.....	124
61.	Suspension of Grant by GOI and/or State Government of Uttar Pradesh .....	124

## General Conditions of Contract

### A. General

<b>1. Definitions</b>	<p>1.1 Boldface type is used to identify defined terms.</p> <ul style="list-style-type: none"><li>(a) The Accepted Contract Amount means the amount accepted in the Letter of Acceptance for the execution and completion of the Works and the remedying of any defects.</li><li>(b) The Adjudicator is the person appointed jointly by the Employer and the Contractor to resolve disputes in the first instance, as provided for in GCC 23.</li><li>(c) Employer means the name <b>as specified in the PCC</b>.</li><li>(d) Bill of Quantities means the priced and completed Bill of Quantities forming part of the Bid.</li><li>(e) Compensation Events are those defined in GCC Clause 42 hereunder.</li><li>(f) The Completion Date is the date of completion of the Works as certified by the Project Manager, in accordance with GCC Sub-Clause 53.1.</li><li>(g) The Contract is the Contract between the Employer and the Contractor to execute, complete, and maintain the Works. It consists of the documents listed in GCC Sub-Clause 2.3 below.</li><li>(h) The Contractor is the party whose Bid to carry out the Works has been accepted by the Employer.</li><li>(i) The Contractor's Bid is the completed bidding document submitted by the Contractor to the Employer.</li><li>(j) The Contract Price is the Accepted Contract Amount stated in the Letter of Acceptance and thereafter as adjusted in accordance with the Contract.</li><li>(k) Days are calendar days; months are calendar months.</li><li>(l) Dayworks are varied work inputs subject to payment on a time basis for the Contractor's employees and Equipment, in addition to payments for associated Materials and Plant.</li><li>(m) A Defect is any part of the Works not completed in accordance with the Contract.</li><li>(n) The Defects Liability Certificate is the certificate issued</li></ul>
-----------------------	---

	<p>by Project Manager upon correction of defects by the Contractor.</p> <p>(o) The Defects Liability Period is the period <b>named in the PCC</b> pursuant to Sub-Clause 34.1 and calculated from the Completion Date.</p> <p>(p) Drawings means the drawings of the Works, as included in the Contract, and any additional and modified drawings issued by (or on behalf of) the Employer in accordance with the Contract, include calculations and other information provided or approved by the Project Manager for the execution of the Contract.</p> <p>(q) The Employer is the party who employs the Contractor to carry out the Works, <b>as specified in the PCC</b>.</p> <p>(r) Equipment is the Contractor’s machinery and vehicles brought temporarily to the Site to construct the Works.</p> <p>(s) “In writing” or “written” means hand-written, type-written, printed or electronically made, and resulting in a permanent record;</p> <p>(t) The Initial Contract Price is the Contract Price listed in the Employer’s Letter of Acceptance.</p> <p>(u) The Intended Completion Date is the date on which it is intended that the Contractor shall complete the Works. The Intended Completion Date is <b>specified in the PCC</b>. The Intended Completion Date may be revised only by the Project Manager by issuing an extension of time or an acceleration order.</p> <p>(v) Materials are all supplies, including consumables, used by the Contractor for incorporation in the Works.</p> <p>(w) Plant is any integral part of the Works that shall have a mechanical, electrical, chemical, or biological function.</p> <p>(x) The Project Manager is the person <b>named in the PCC</b> (or any other competent person appointed by the Employer and notified to the Contractor, to act in replacement of the Project Manager) who is responsible for supervising the execution of the Works and administering the Contract.</p> <p>(y) PCC means Particular Conditions of Contract.</p> <p>(z) The Site is the area <b>defined as such in the PCC</b>.</p> <p>(aa) Site Investigation Reports are those that were included</p>
--	--

	<p>in the bidding document and are factual and interpretative reports about the surface and subsurface conditions at the Site.</p> <p>(bb) Specification means the Specification of the Works included in the Contract and any modification or addition made or approved by the Project Manager.</p> <p>(cc) The Start Date is <b>given in the PCC</b>. It is the latest date when the Contractor shall commence execution of the Works. It does not necessarily coincide with any of the Site Possession Dates.</p> <p>(dd) A Subcontractor is a person or corporate body who has a Contract with the Contractor to carry out a part of the work in the Contract, which includes work on the Site.</p> <p>(ee) Temporary Works are works designed, constructed, installed, and removed by the Contractor that are needed for construction or installation of the Works.</p> <p>(ff) A Variation is an instruction given by the Project Manager which varies the Works.</p> <p>(gg) The Works are what the Contract requires the Contractor to construct, install, and turn over to the Employer, <b>as defined in the PCC</b>.</p>
<p><b>2. Interpretation</b></p>	<p>2.1 In interpreting these GCC, words indicating one gender include all genders. Words indicating the singular also include the plural and words indicating the plural also include the singular. Headings have no significance. Words have their normal meaning under the language of the Contract unless specifically defined. The Project Manager shall provide instructions clarifying queries about these GCC.</p> <p>2.2 If sectional completion is <b>specified in the PCC</b>, references in the GCC to the Works, the Completion Date, and the Intended Completion Date apply to any Section of the Works (other than references to the Completion Date and Intended Completion Date for the whole of the Works).</p> <p>2.3 The documents forming the Contract shall be interpreted in the following order of priority:</p> <ul style="list-style-type: none"> <li>(a) Agreement,</li> <li>(b) Letter of Acceptance,</li> <li>(c) Contractor’s Bid,</li> <li>(d) Particular Conditions of Contract,</li> </ul>

	<ul style="list-style-type: none"> <li>(e) General Conditions of Contract, including Appendices,</li> <li>(f) Specifications,</li> <li>(g) Drawings,</li> <li>(h) Bill of Quantities, and</li> <li>(i) any other document <b>listed in the PCC</b> as forming part of the Contract.</li> </ul>
<b>3. Language and Law</b>	<p>3.1 The language of the Contract and the law governing the Contract are <b>stated in the PCC</b>.</p> <p>3.2 Throughout the execution of the Contract, the Contractor shall comply with the import of goods and services prohibitions in the Employer's country when</p> <ul style="list-style-type: none"> <li>(a) as a matter of law or official regulations, the Employer's country prohibits commercial relations with that country.</li> </ul>
<b>4. Project Manager's Decisions</b>	<p>4.1 Except where otherwise specifically stated, the Project Manager shall decide contractual matters between the Employer and the Contractor in the role representing the Employer.</p>
<b>5. Delegation</b>	<p>5.1 Otherwise <b>specified in the PCC</b>, the Project Manager may delegate any of his duties and responsibilities to other people, except to the Adjudicator, after notifying the Contractor, and may revoke any delegation after notifying the Contractor.</p>
<b>6. Communications</b>	<p>6.1 Communications between parties that are referred to in the Conditions shall be effective only when in writing. A notice shall be effective only when it is delivered and receipt is obtained against the delivery of the notice.</p>
<b>7. Subcontracting</b>	<p>7.1 Sub-Contracting shall not be allowed under this contract..</p>
<b>8. Other Contractors</b>	<p>8.1 The Contractor shall cooperate and share the Site with other contractors, public authorities, utilities, and the Employer between the dates given in the Schedule of Other Contractors, as <b>referred to in the PCC</b>. The Contractor shall also provide facilities and services for them as described in the Schedule. The Employer may modify the Schedule of Other Contractors, and shall notify the Contractor of any such modification.</p>



<p><b>9. Personnel and Equipment</b></p>	<p>9.1 The Contractor shall employ the key personnel and use the equipment identified in its Bid, to carry out the Works or other personnel and equipment approved by the Project Manager. The Project Manager shall approve any proposed replacement of key personnel and equipment only if their relevant qualifications or characteristics are substantially equal to or better than those proposed in the Bid.</p> <p>9.2 If the Project Manager asks the Contractor to remove a person who is a member of the Contractor’s staff or work force, stating the reasons, the Contractor shall ensure that the person leaves the Site within seven days and has no further connection with the work in the Contract.</p> <p>9.3 If the Employer, Project Manager or Contractor determines, that any employee of the Contractor be determined to have engaged in Fraud and Corruption during the execution of the Works, then that employee shall be removed in accordance with Clause 9.2 above.</p>
<p><b>10. Employer’s and Contractor’s Risks</b></p>	<p>10.1 The Employer carries the risks which this Contract states are Employer’s risks, and the Contractor carries the risks which this Contract states are Contractor’s risks.</p>
<p><b>11. Employer’s Risks</b></p>	<p>11.1 From the Start Date until the Defects Liability Certificate has been issued, the following are Employer’s risks:</p> <p>11.2 The Employer is responsible for the excepted risks which are (a) in so far as they directly affect the execution of the Works in India, the risks of war, hostilities, invasion, act of foreign enemies, rebellion, revolution, insurrection or military or usurped power, civil war, riot commotion or disorder (unless restricted to the Contractor’s employees) and contamination from any nuclear fuel or nuclear waste or radioactive toxic explosive,(b) a cause due solely to the design of the Works, other than the Contractor’s design.</p> <p>11.3 From the Completion Date until the Defects Liability Certificate has been issued, the risk of loss of or damage to the Works, Plant, and Materials is an Employer’s risk except loss or damage due to</p> <ul style="list-style-type: none"> <li>(a) a Defect which existed on the Completion Date,</li> <li>(b) an event occurring before the Completion Date, which was not itself an Employer’s risk, or</li> <li>(c) the activities of the Contractor on the Site after the</li> </ul>

	Completion Date.
<b>12. Contractor's Risks</b>	12.1 From the Starting Date until the Defects Liability Certificate has been issued, All risks of loss of or damage of physical property and of personal injury and death which arise during and in consequence of the performance of the Contract other than the excepted risks referred to in clause 11.2, are the responsibility of the Contractor.
<b>13. Insurance</b>	<p>13.1 The Contractor shall provide, in the joint names of the Employer and the Contractor, insurance cover from the Start Date to the end of the Defects Liability Period, in the amounts and deductibles <b>stated in the PCC</b> for the following events which are due to the Contractor's risks:</p> <ul style="list-style-type: none"> <li>(a) loss of or damage to the Works, Plant, and Materials;</li> <li>(b) loss of or damage to Equipment;</li> <li>(c) loss of or damage to property (except the Works, Plant, Materials, and Equipment) in connection with the Contract; and</li> <li>(d) personal injury or death.</li> </ul> <p>13.2 Policies and certificates for insurance shall be delivered by the Contractor to the Project Manager for the Project Manager's approval before the Start Date. All such insurance shall provide for compensation to be payable in the types and proportions of currencies required to rectify the loss or damage incurred.</p> <p>13.3 If the Contractor does not provide any of the policies and certificates required, the Employer may effect the insurance which the Contractor should have provided and recover the premiums the Employer has paid from payments otherwise due to the Contractor or, if no payment is due, the payment of the premiums shall be a debt due.</p> <p>13.4 Alterations to the terms of an insurance shall not be made without the approval of the Project Manager.</p> <p>13.5 Both parties shall comply with any conditions of the insurance policies.</p>
<b>14. Site Data</b>	14.1 The Contractor shall be deemed to have examined any Site Data <b>referred to in the PCC</b> , supplemented by any information available to the Contractor.
<b>15. Contractor to Construct the</b>	15.1 The Contractor shall construct and install the Works in

<p><b>Works</b></p>	<p>accordance with the Specifications and Drawings.</p> <p>15.2 The Contractor shall be responsible for maintaining the safety of all activities on the site, including smooth flow of traffic at his own cost as per guidelines including any amendment(s) of the IRC/MORT&amp;H/PWD/CPWD.</p> <p>15.3 In respect of all labour directly or indirectly employed in the work for the performance of the Contractor's part of this contract, the Contractor shall at his own expense arrange for the safety provisions as per Safety Code framed from time to time and shall at his own expense provide for all facilities in connection therewith. In case the Contractor fails to make arrangement and provide necessary facilities as aforesaid, the Employer shall be at liberty to make arrangement and provide facilities as aforesaid and recover the costs incurred in that behalf from the Contractor. The decision of the Engineer in this regard shall be final and no claim on account of this shall be entertained.</p>
<p><b>16. The Works to Be Completed by the Intended Completion Date</b></p>	<p>16.1 The Contractor may commence execution of the Works on the Start Date and shall carry out the Works in accordance with the Program submitted by the Contractor, as updated with the approval of the Project Manager, and complete them by the Intended Completion Date.</p>
<p><b>17. Approval by the Project Manager</b></p>	<p>17.1 The Contractor shall submit Specifications and Drawings showing the proposed Temporary Works to the Project Manager, for his approval.</p> <p>17.2 The Contractor shall be responsible for design of Temporary Works.</p> <p>17.3 The Project Manager's approval shall not alter the Contractor's responsibility for design of the Temporary Works.</p> <p>17.4 The Contractor shall obtain approval of third parties to the design of the Temporary Works, where required.</p> <p>17.5 All Drawings prepared by the Contractor for the execution of the temporary or permanent Works, are subject to prior approval by the Project Manager before this use.</p>
<p><b>18. Safety</b></p>	<p>18.1 The Contractor shall be responsible for the safety of all activities on the Site including personnel and equipment. The contractors shall follow all the applicable rules and regulations of the Employer's country pertaining to the safety of the</p>

	personnel and material.
<b>19. Discoveries</b>	19.1 Anything of historical or other interest or of significant value unexpectedly discovered on the Site shall be the property of the Employer. The Contractor shall notify the Project Manager of such discoveries and carry out the Project Manager's instructions for dealing with them.
<b>20. Possession of the Site</b>	20.1 The Employer shall give possession of all parts of the Site to the Contractor. If possession of a part is not given by the date <b>stated in the PCC</b> , the Employer shall be deemed to have delayed the start of the relevant activities, and this shall be a Compensation Event.
<b>21. Access to the Site</b>	21.1 The Contractor shall allow the Project Manager and any person authorized by the Project Manager access to the Site and to any place where work in connection with the Contract is being carried out or is intended to be carried out.
<b>22. Instructions, Inspections and Audits</b>	22.1 The Contractor shall carry out all instructions of the Project Manager which comply with the applicable laws where the Site is located.
	22.2 The Contractor shall keep, and shall make all reasonable efforts to cause its personnel to keep, accurate and systematic accounts and records in respect of the Works in such form and details as will clearly identify relevant time changes and costs.
	22.3 The Contractor shall permit and shall cause its personnel to permit, the Employer and/or persons appointed by the Employer to inspect the Site and/or the accounts and records relating to the performance of the Contract and the submission of the bid, and to have such accounts and records audited by auditors appointed by the Employer if requested by the Employer. The Contractor's and its 'Personnel' attention is drawn to Sub-Clause 25.1 which provides, inter alia, that acts intended to materially impede the exercise of the Employer's inspection and audit rights provided for under Sub-Clause 22.2 constitute a prohibited practice subject to contract termination (as well as to a determination of ineligibility pursuant to the Employer's prevailing sanctions procedures).
<b>23. Appointment of the Adjudicator</b>	23.1 The Adjudicator shall be appointed jointly by the Employer and the Contractor, at the time of the Employer's issuance of the Letter of Acceptance. If, in the Letter of Acceptance, the Employer does not agree on the appointment of the Adjudicator, the Employer will request the Appointing Authority <b>designated in the PCC</b> , to appoint the Adjudicator within 14 days of

	<p>receipt of such request.</p> <p>23.2 Should the Adjudicator resign or die, or should the Employer and the Contractor agree that the Adjudicator is not functioning in accordance with the provisions of the Contract, a new Adjudicator shall be jointly appointed by the Employer and the Contractor. In case of disagreement between the Employer and the Contractor, within 30 days, the Adjudicator shall be designated by the Appointing Authority <b>designated in the PCC</b> at the request of either party, within 14 days of receipt of such request.</p>
<p><b>24. Procedure for Disputes</b></p>	<p>24.1 If the Contractor believes that a decision taken by the Project Manager was either outside the authority given to the Project Manager by the Contract or that the decision was wrongly taken, the decision shall be referred to the Adjudicator within 14 days of the notification of the Project Manager’s decision.</p> <p>24.2 The Adjudicator shall give a decision in writing within 28 days of receipt of a notification of a dispute.</p> <p>24.3 The Adjudicator shall be paid by the hour at the <b>rate specified in the PCC</b>, together with reimbursable expenses of the types <b>specified in the PCC</b>, and the cost shall be divided equally between the Employer and the Contractor, whatever decision is reached by the Adjudicator. Either party may refer a decision of the Adjudicator to an Arbitrator within 28 days of the Adjudicator’s written decision. If neither party refers the dispute to arbitration within the above 28 days, the Adjudicator’s decision shall be final and binding.</p> <p>24.4 The arbitration shall be conducted in accordance with the arbitration procedures published by the institution named and in the place <b>specified in the PCC</b>.</p>
<p><b>25. Fraud and Corruption</b></p>	<p>25.1 The Employer requires compliance with its policy in regard to corrupt and fraudulent practices as set forth in Appendix to the GCC.</p> <p>25.2 The Employer requires the Contractor to disclose any commissions or fees that may have been paid or are to be paid to agents or any other party with respect to the bidding process or execution of the Contract. The information disclosed must include at least the name and address of the agent or other party, the amount and currency, and the purpose of the commission, gratuity or fee.</p>

## B. Time Control

<p><b>26. Program</b></p>	<p>26.1 Within the time <b>stated in the PCC</b>, after the date of the Letter of Acceptance, the Contractor shall submit to the Project Manager for approval a Program showing the general methods, arrangements, order, and timing for all the activities in the Works. In the case of a lump-sum contract, the activities in the Program shall be consistent with those in the Activity Schedule.</p> <p>26.2 An update of the Program shall be a program showing the actual progress achieved on each activity and the effect of the progress achieved on the timing of the remaining work, including any changes to the sequence of the activities.</p> <p>26.3 The Contractor shall submit to the Project Manager for approval an updated Program at intervals no longer than the period <b>stated in the PCC</b>. If the Contractor does not submit an updated Program within this period, the Project Manager may withhold the amount <b>stated in the PCC</b> from the next payment certificate and continue to withhold this amount until the next payment after the date on which the overdue Program has been submitted. In the case of a lump-sum contract, the Contractor shall provide an updated Activity Schedule within 14 days of being instructed to by the Project Manager.</p> <p>26.4 The Project Manager's approval of the Program shall not alter the Contractor's obligations. The Contractor may revise the Program and submit it to the Project Manager again at any time. A revised Program shall show the effect of Variations and Compensation Events.</p>
<p><b>27. Extension of the Intended Completion Date</b></p>	<p>27.1 The Project Manager shall extend the Intended Completion Date if a Compensation Event occurs or a Variation is issued which makes it impossible for Completion to be achieved by the Intended Completion Date without the Contractor taking steps to accelerate the remaining work, which would cause the Contractor to incur additional cost.</p> <p>27.2 The Project Manager shall decide whether and by how much to extend the Intended Completion Date within 21 days of the Contractor asking the Project Manager for a decision upon the effect of a Compensation Event or Variation and submitting full supporting information. If the Contractor has failed to give early warning of a delay or has failed to cooperate in dealing with a delay, the delay by this failure shall not be considered in assessing the new Intended Completion Date.</p>

<p><b>28. Acceleration</b></p>	<p>28.1 When the Employer wants the Contractor to finish before the Intended Completion Date, the Project Manager shall obtain priced proposals for achieving the necessary acceleration from the Contractor. If the Employer accepts these proposals, the Intended Completion Date shall be adjusted accordingly and confirmed by both the Employer and the Contractor.</p> <p>28.2 If the Contractor's priced proposals for an acceleration are accepted by the Employer, they are incorporated in the Contract Price and treated as a Variation.</p>
<p><b>29. Delays Ordered by the Project Manager</b></p>	<p>29.1 The Project Manager may instruct the Contractor to delay the start or progress of any activity within the Works.</p>
<p><b>30. Management Meetings</b></p>	<p>30.1 Either the Project Manager or the Contractor may require the other to attend a management meeting. The business of a management meeting shall be to review the plans for remaining work and to deal with matters raised in accordance with the early warning procedure.</p> <p>30.2 The Project Manager shall record the business of management meetings and provide copies of the record to those attending the meeting and to the Employer. The responsibility of the parties for actions to be taken shall be decided by the Project Manager either at the management meeting or after the management meeting and stated in writing to all who attended the meeting.</p>
<p><b>31. Early Warning</b></p>	<p>31.1 The Contractor shall warn the Project Manager at the earliest opportunity of specific likely future events or circumstances that may adversely affect the quality of the work, increase the Contract Price, or delay the execution of the Works. The Project Manager may require the Contractor to provide an estimate of the expected effect of the future event or circumstance on the Contract Price and Completion Date. The estimate shall be provided by the Contractor as soon as reasonably possible.</p> <p>31.2 The Contractor shall cooperate with the Project Manager in making and considering proposals for how the effect of such an event or circumstance can be avoided or reduced by anyone involved in the work and in carrying out any resulting instruction of the Project Manager.</p>
<p><b>C. Quality Control</b></p>	
<p><b>32. Identifying</b></p>	<p>32.1 The Project Manager shall check the Contractor's work and</p>

<p><b>Defects</b></p>	<p>notify the Contractor of any Defects that are found. Such checking shall not affect the Contractor’s responsibilities. The Project Manager may instruct the Contractor to search for a Defect and to uncover and test any work that the Project Manager considers may have a Defect.</p>
<p><b>33. Tests</b></p>	<p>33.1 If the Project Manager instructs the Contractor to carry out a test not specified in the Specification to check whether any work has a Defect and the test shows that it does, the Contractor shall pay for the test and any samples. If there is no Defect, the test shall be a Compensation Event.</p> <p>33.2 The Contractor shall constitute quality assurance system to demonstrate compliance with the requirements of the Contract. The system shall be in accordance with the details stated in the Contract. The Project Manager shall be entitled to audit any aspect of the system.</p> <p>33.3 Details of all procedures and compliance documents shall be submitted to the Project Manager for information before each design and execution stage is commenced. When any document of a technical nature is issued to the Project Manager, evidence of the prior approval by the Contractor himself shall be apparent on the document itself.</p> <p>33.4 For carrying out mandatory tests as prescribed in the specifications, the Contractor shall establish field laboratory at the location decided by Project Manager or Conduct the tests a reputed institute in consultation with the Project Manager. If the field laboratory is established, the field laboratory will have minimum of equipment as required to conduct the tests. The contractor shall be solely responsible for:</p> <ul style="list-style-type: none"> <li>i) Carrying out the mandatory tests prescribed in the Specifications, and</li> <li>ii) For the correctness of the test results, whether performed in his laboratory or elsewhere.</li> </ul> <p>33.5 The Project Manager will be free to conduct surprise, random or in situ checks any time during the execution and after the completion of the work but not later than the Defect Liability Period, so as to have cross check in quality of works/projects and compliance to specifications and standards at all stages of the work.</p> <p>33.6 Nothing in this clause shall reduce the overall responsibility of the Contractor regarding quality and he shall remain liable for</p>



	any defect in the execution of the Project/Works at all stages.
<b>34. Correction of Defects &amp; Operation and maintenance</b>	<p>34.1 The Project Manager shall give notice to the Contractor of any Defects before the end of the Defects Liability Period, which begins at Completion, and is <b>defined in the PCC</b>. The Defects Liability Period shall be extended for as long as Defects remain to be corrected.</p> <p>34.2 Every time notice of a Defect is given, the Contractor shall correct the notified Defect within the length of time specified by the Project Manager's notice.</p> <p>34.3 Operation and Maintenance as specified in the P.C.C.</p>
<b>35. Uncorrected Defects</b>	35.1 If the Contractor has not corrected a Defect within the time specified in the Project Manager's notice, the Project Manager shall assess the cost of having the Defect corrected, and the Contractor shall pay this amount.
<b>D. Cost Control</b>	
<b>36. Contract Price</b>	36.1 The Bill of Quantities shall contain priced items for the Works to be performed by the Contractor. The Bill of Quantities is used to calculate the Contract Price. The Contractor will be paid for the quantity of the work accomplished at the rate in the Bill of Quantities for each item.
<b>37. Changes in the Contract Price</b>	<p>37.1 The Engineer shall have power to make any variations, alterations omission, additions to or substitutions for the original specifications, drawings, designs and instructions that may appear to be necessary or advisable during the progress of the work, and the Contractor shall be bound to carry out the work in accordance with any instructions which may be given to him in writing, signed by the Engineer. Such alterations/additions/substitutions shall not invalidate the contract and shall be carried out by the Contractor on the same conditions in all respect on which he agreed to do the main work. The time of completion of the work shall be extended in the proportion that he altered, additional or substituted works bears to the original contract work and the certificate of the Engineer shall be conclusive as to such proportion.</p> <p>37.2 If the final quantity of the work done differs from the quantity in the Bill of Quantities for the by more than 25 percent, the Project Manager shall adjust the rate to allow for the change, duly considering:</p> <p>(a) Justification for rate adjustment as furnished by the</p>

	<p>Contractor.</p> <p>(b) Economies resulting from increase in quantities by way of reduced plant, equipment and overhead costs.</p> <p>(c) Entitlement of the Contractor to compensation events where such events are caused by any additional work.</p> <p>(d) The revised rates will be applicable to the quantity that exceeds 25% limit and not on the entire quantity.</p> <p>37.3 The Project Manager shall not adjust rates from changes in quantities if thereby the Initial Contract Price is exceeded by more than 15 percent, except with the prior approval of the Employer.</p> <p>37.4 If requested by the Project Manager, the Contractor shall provide the Project Manager with a detailed cost breakdown of any rate in the Bill of Quantities.</p>
<p><b>38. Variations</b></p>	<p>38.1 All Variations shall be included in updated Programs produced by the Contractor.</p> <p>38.2 The Contractor shall provide the Project Manager with a quotation for carrying out the Variation when requested to do so by the Project Manager. The Project Manager shall assess the quotation, which shall be given within seven (7) days of the request or within any longer period stated by the Project Manager and before the Variation is ordered.</p> <p>38.3 If the work in the Variation corresponds to an item description in the Bill of Quantities and if, in the opinion of the Project Manager, the quantity of work above the limit stated in Sub-Clause 37.1 or the timing of its execution do not cause the cost per unit of quantity to change, the rate in the Bill of Quantities shall be used to calculate the value of the Variation. If the cost per unit of quantity changes, or if the nature or timing of the work in the Variation does not correspond with items in the Bill of Quantities, the quotation by the Contractor shall be in the form of new rates for the relevant items of work.</p> <p>38.4 If the Contractor's quotation is unreasonable, the Project Manager may order the Variation and make a change to the Contract Price, which shall be based on the Project Manager's own forecast of the effects of the Variation on the Contractor's costs.</p> <p>38.5 If the Project Manager decides that the urgency of varying the work would prevent a quotation being given and considered without delaying the work, no quotation shall be given and the</p>

	<p>Variation shall be treated as a Compensation Event.</p> <p>38.6 The Contractor shall not be entitled to additional payment for costs that could have been avoided by giving early warning.</p> <p>38.7 <b>Value Engineering:</b> The Contractor may prepare, at its own cost, a value engineering proposal at any time during the performance of the contract. The value engineering proposal shall, at a minimum, include the following;</p> <ul style="list-style-type: none"> <li>(a) the proposed change(s), and a description of the difference to the existing contract requirements;</li> <li>(b) a full cost/benefit analysis of the proposed change(s) including a description and estimate of costs (including life cycle cost) the Employer may incur in implementing the value engineering proposal; and</li> <li>(c) a description of any effect(s) of the change on performance/functionality.</li> </ul> <p>The Employer may accept the value engineering proposal if the proposal demonstrates benefits that:</p> <ul style="list-style-type: none"> <li>(a) accelerates the contract completion period; or</li> <li>(b) reduces the Contract Price or the life cycle costs to the Employer; or</li> <li>(c) improves the quality, efficiency, safety or sustainability of the Facilities; or</li> <li>(d) yields any other benefits to the Employer,</li> </ul> <p>without compromising the functionality of the Works.</p> <p>If the value engineering proposal is approved by the Employer and results in:</p> <ul style="list-style-type: none"> <li>(a) a reduction of the Contract Price; the amount to be paid to the Contractor shall be the <b>percentage specified in the PCC</b> of the reduction in the Contract Price; or</li> <li>(b) an increase in the Contract Price; but results in a reduction in life cycle costs due to any benefit described in (a) to (d) above, the amount to be paid to the Contractor shall be the full increase in the Contract Price.</li> </ul>
<p><b>39. Cash Flow</b></p>	<p>39.1 When the Program, is updated, the Contractor shall provide the</p>

<p><b>Forecasts</b></p>	<p>Project Manager with an updated cash flow forecast. The cash flow forecast shall include different currencies, as defined in the Contract, converted as necessary using the Contract exchange rates.</p>
<p><b>40. Payment Certificates</b></p>	<p>40.1 The Contractor shall submit to the Project Manager monthly statements with all requisite supporting documents of the estimated value of the work executed less the cumulative amount certified previously.</p> <p>40.2 The requisite supporting documents shall contain, Request For Inspection (RFIs), measurements and Quantities (jointly measure by the representative of the Contractor and the Employer) of items of work done since last bill, Copies of the quality control tests in specified format covering the work done since last bill, copies of the instructions recorded in the instruction book containing the instructions and compliance made thereof, covering the work done since last bill, applicable work done/as built drawings, details of approvals (as required) obtained. The contractor shall submit all the bills on the printed/computerised forms.</p> <p>40.3 The Project Manager shall check the Contractor’s monthly statement and certify the amount to be paid to the Contractor.</p> <p>40.4 The value of work executed shall be determined by the Project Manager.</p> <p>40.5 The value of work executed shall comprise the value of the quantities of work in the Bill of Quantities that have been completed.<sup>1</sup></p> <p>40.6 The value of work executed shall include the valuation of Variations and Compensation Events.</p> <p>40.7 The Project Manager may exclude any item certified in a previous certificate or reduce the proportion of any item previously certified in any certificate in the light of later information.</p>
<p><b>41. Payments</b></p>	<p>41.1 Payments shall be adjusted for deductions for advance payments and retention. The Employer shall pay the Contractor the amounts certified by the Project Manager within 28 days of</p>

<sup>1</sup> In lump-sum contracts, replace this paragraph with the following: “The value of work executed shall comprise the value of completed activities in the Activity Schedule.”

	<p>the date of each certificate.</p> <p>41.2 If an amount certified is increased in a later certificate or as a result of an award by the Adjudicator or an Arbitrator, the Contractor shall be paid interest upon the delayed payment as set out in this clause. Interest shall be calculated from the date upon which the increased amount would have been certified in the absence of dispute.</p> <p>41.3 Unless otherwise stated, all payments and deductions shall be paid or charged in the proportions of currencies comprising the Contract Price.</p> <p>41.4 Items of the Works for which no rate or price has been entered in shall not be paid for by the Employer and shall be deemed covered by other rates and prices in the Contract.</p>
<p><b>42. Compensation Events</b></p>	<p>42.1 The following shall be Compensation Events:</p> <ul style="list-style-type: none"> <li>(a) The Employer does not give access to a part of the Site by the Site Possession Date pursuant to GCC Sub-Clause 20.1.</li> <li>(b) The Employer modifies the Schedule of Other Contractors in a way that affects the work of the Contractor under the Contract.</li> <li>(c) The Project Manager orders a delay or does not issue Drawings, Specifications, or instructions required for execution of the Works on time.</li> <li>(d) The Project Manager instructs the Contractor to uncover or to carry out additional tests upon work, which is then found to have no Defects.</li> <li>(e) The Project Manager unreasonably does not approve a subcontract to be let.</li> <li>(f) Ground conditions are substantially more adverse than could reasonably have been assumed before issuance of the Letter of Acceptance from the information issued to bidders (including the Site Investigation Reports), from information available publicly and from a visual inspection of the Site.</li> <li>(g) The Project Manager gives an instruction for dealing with an unforeseen condition, caused by the Employer, or additional work required for safety or other reasons.</li> <li>(h) Other contractors, public authorities, utilities, or the</li> </ul>

	<p>Employer does not work within the dates and other constraints stated in the Contract, and they cause delay or extra cost to the Contractor.</p> <ul style="list-style-type: none"> <li>(i) The advance payment is delayed.</li> <li>(j) The effects on the Contractor of any of the Employer's Risks.</li> <li>(k) The Project Manager unreasonably delays issuing a Certificate of Completion.</li> </ul> <p>42.2 If a Compensation Event would cause additional cost or would prevent the work being completed before the Intended Completion Date, the Contract Price shall be reasonably increased and/or the Intended Completion Date shall be reasonably extended. The Project Manager shall decide reasonableness of whether and by how much the Contract Price shall be increased and whether and by how much the Intended Completion Date shall be extended.</p> <p>42.3 As soon as information demonstrating the effect of each Compensation Event upon the Contractor's forecast cost has been provided by the Contractor, it shall be assessed by the Project Manager, and the Contract Price shall be adjusted accordingly. If the Contractor's forecast is deemed unreasonable, the Project Manager shall adjust the Contract Price based on the Project Manager's own forecast. The Project Manager shall assume that the Contractor shall react competently and promptly to the event.</p> <p>42.4 The Contractor shall not be entitled to compensation to the extent that the Employer's interests are adversely affected by the Contractor's not having given admissible early warning or not having admissibly cooperated with the Project Manager.</p>
<p><b>43. Tax</b></p>	<p>43.1 The rates quoted by the Contractor shall be deemed to be inclusive of all the taxes, levies, duties etc. including their variations as notified by the concerned authority from time to time, and also of all the new taxes and levies that may be imposed that the Contractor will have to pay for the performance of this Contract. The Project Manager on behalf of the Employer will perform such duties in regard to the deduction of such taxes at source as per applicable law.</p> <p>43.2 The Contractor shall comply with the proper bye-laws and legal orders of the local body or public authority, authority under the jurisdiction of which the work is executed and pay all fees and charges for which he may be liable. Nothing extra shall be</p>

	payable on this account.
<b>44. Currencies</b>	44.1 Where payments are made in currencies other than the currency of the Employer’s country <b>specified in the PCC</b> , the exchange rates used for calculating the amounts to be paid shall be the exchange rates stated in the Contractor’s Bid.
<b>45. Price Adjustment</b>	<p>45.1 Prices shall be adjusted for fluctuations in the cost of inputs only if <b>provided for in the PCC</b>. If so provided, the amounts certified in each payment certificate, before deducting for Advance Payment, shall be adjusted by applying the respective price adjustment factor to the payment amounts due in each currency. A separate formula of the type specified below applies to each Contract currency:</p> $P_c = A_c + B_c \text{ Imc/Ioc}$ <p>where:</p> <p><math>P_c</math> is the adjustment factor for the portion of the Contract Price payable in a specific currency “c.”</p> <p><math>A_c</math> and <math>B_c</math> are coefficients <b>specified in the PCC</b>, representing the nonadjustable and adjustable portions, respectively, of the Contract Price payable in that specific currency “c;” and</p> <p><math>Imc</math> is the index prevailing at the end of the month being invoiced and <math>Ioc</math> is the index prevailing 28 days before Bid opening for inputs payable; both in the specific currency “c.”</p> <p>45.2 If the value of the index is changed after it has been used in a calculation, the calculation shall be corrected and an adjustment made in the next payment certificate. The applicable index value shall be deemed to take account of all changes in cost due to fluctuations in costs.</p>
<b>46. Retention</b>	<p>46.1 The Employer shall retain from each payment due to the Contractor the proportion <b>stated in the PCC</b> until Completion of the whole of the Works.</p> <p>46.2 Upon the issue of a Certificate of Completion of the Works by the Project Manager, in accordance with GCC 51.1, half the total amount retained shall be repaid to the Contractor and half when the Defects Liability Period has passed and the Project Manager has certified that all Defects notified by the Project Manager to the Contractor before the end of this period have been corrected. The Contractor may substitute retention money</p>

	with an “on demand” Bank guarantee.
<b>47. Liquidated Damages</b>	<p>47.1 The Contractor shall pay liquidated damages to the Employer at the rate per day <b>stated in the PCC</b> for each day that the Completion Date is later than the Intended Completion Date. The total amount of liquidated damages shall not exceed the amount <b>defined in the PCC</b>. The Employer may deduct liquidated damages from payments due to the Contractor. Payment of liquidated damages shall not affect the Contractor’s liabilities.</p> <p>47.2 If the Intended Completion Date is extended after liquidated damages have been paid, the Project Manager shall correct any overpayment of liquidated damages by the Contractor by adjusting the next payment certificate. The Contractor shall be paid interest on the overpayment, calculated from the date of payment to the date of repayment, at the rates specified in GCC Sub-Clause 41.1.</p>
<b>48. Bonus</b>	<p>48.1 The Contractor shall be paid a Bonus calculated at the rate per calendar day <b>stated in the PCC</b> for each day (less any days for which the Contractor is paid for acceleration) that the Completion is earlier than the Intended Completion Date. The Project Manager shall certify that the Works are complete, although they may not be due to be complete.</p>
<b>49. Advance Payment</b>	<p>49.1 The Employer shall make advance payment to the Contractor of the amounts <b>stated in the PCC</b> by the date <b>stated in the PCC</b>, against provision by the Contractor of an Unconditional irrevocable Bank Guarantee in a form and by Employer acceptable to the Employer in amounts and currencies equal to the advance payment. The Guarantee shall remain effective until the advance payment has been repaid, but the amount of the Guarantee shall be progressively reduced by the amounts repaid by the Contractor. Interest shall be charged at the rate 12% per annum on the advance payment.</p> <p>49.2 The Contractor is to use the advance payment only to pay for Equipment, Plant, Materials, and mobilization expenses required specifically for execution of the Contract. The Contractor shall demonstrate that advance payment has been used in this way by supplying copies of invoices or other documents to the Project Manager.</p> <p>49.3 The advance payment shall be repaid by deducting proportionate amounts from payments otherwise due to the Contractor, following the schedule of completed percentages of the Works on a payment basis, but not later than the completion of the</p>



	<p>seventy five percent (75%) of the initial project time period. No account shall be taken of the advance payment or its repayment in assessing valuations of work done, Variations, price adjustments, Compensation Events, Bonuses, or Liquidated Damages.</p> <p>49.4 <b>Secured Advance:</b> The contractor ,on signing an indenture in the form to be specified by the Project Manager, shall be entitled to be paid, during the execution of work, upto 75% of the estimated value of any materials, which, in the opinion of the Project Manager, are non-perishable, non-fragile, non-combustible and which have been procured and adequately stored against damage, but which have not been incorporated in the works at the time of making advance.</p> <p>This secured advance is subject to the following:</p> <ol style="list-style-type: none"> <li>a. The materials are in accordance with the specification for works;</li> <li>b. Such materials have been delivered to site, and are properly stored and protected against damage or deterioration to the satisfaction of the Project Manager. The contractor shall store the bulk material in measurable stacks;</li> <li>c. The contractor’s records of the requirements, orders, receipt and use of materials are kept in a form approved by the Project Manager and such records shall be available for inspection by the Engineer;</li> <li>d. The contractor has submitted with his monthly statement the estimated value of the materials on site together with such documents as may be required by the Project Manager for the purpose of valuation of the materials and providing evidence of ownership and payment thereof;</li> <li>e. Ownership of such materials shall be deemed to vest in the Employer for which the Contractor has submitted an Indemnity Bond in an acceptable format; and</li> </ol> <p>49.5 The quantities of materials are not excessive and shall be used within a reasonable time as determined by the Project Manager.</p>
<p><b>50. Securities</b></p>	<p>50.1 The Performance Security (including additional security for unbalanced bids) shall be provided to the Employer no later than the date specified in the Letter of Acceptance and shall be issued in an amount <b>specified in the PCC</b>, by a bank acceptable</p>

	<p>to the Employer, and denominated in the types and proportions of the currencies in which the Contract Price is payable. The Performance Security shall be valid until a date 60 days from the date of expiry of Defects Liability Period and additional security for unbalanced bids shall be valid until a date 28 days from the date of issue of the certificate of completion by the Project Manager/Employer.</p>
<b>51. Dayworks</b>	<p>51.1 If applicable, the Dayworks rates in the Contractor’s Bid shall be used only when the Project Manager has given written instructions in advance for additional work to be paid for in that way.</p> <p>51.2 All work to be paid for as Dayworks shall be recorded by the Contractor on forms approved by the Project Manager. Each completed form shall be verified and signed by the Project Manager within two days of the work being done.</p> <p>51.3 The Contractor shall be paid for Dayworks subject to obtaining signed Dayworks forms.</p>
<b>52. Cost of Repairs</b>	<p>52.1 Loss or damage to the Works or Materials to be incorporated in the Works between the Start Date and the end of the Defects Correction periods shall be remedied by the Contractor at the Contractor’s cost if the loss or damage arises from the Contractor’s acts or omissions.</p>
<b>E. Finishing the Contract</b>	
<b>53. Completion</b>	<p>53.1 The Contractor shall request the Project Manager to issue a Certificate of Completion of the Works, and the Project Manager shall do so upon deciding that the whole of the Works is completed.</p>
<b>54. Taking Over</b>	<p>54.1 The Employer shall take over the Site and the Works within seven days of the Project Manager’s issuing a certificate of Completion.</p>
<b>55. Final Account</b>	<p>55.1 The Contractor shall supply the Project Manager with a detailed account of the total amount that the Contractor considers payable under the Contract before the end of the Defects Liability Period. The Project Manager shall issue a Defects Liability Certificate and certify any final payment that is due to the Contractor within 56 days of receiving the Contractor’s account if it is correct and complete. If it is not, the Project Manager shall issue within 56 days a schedule that states the scope of the corrections or additions that are necessary. If the Final Account is still unsatisfactory after it</p>

	<p>has been resubmitted, the Project Manager shall decide on the amount payable to the Contractor and issues a payment certificate.</p>
<p><b>56. Operating and Maintenance Manuals</b></p>	<p>56.1 If “as built” Drawings and/or operating and maintenance manuals are required, the Contractor shall supply them by the dates <b>stated in the PCC</b>.</p> <p>56.2 If the Contractor does not supply the Drawings and/or manuals by the dates <b>stated in the PCC</b> pursuant to GCC Sub-Clause 56.1, or they do not receive the Project Manager’s approval, the Project Manager shall withhold the amount <b>stated in the PCC</b> from payments due to the Contractor.</p>
<p><b>57. Termination</b></p>	<p>57.1 The Employer or the Contractor may terminate the Contract if the other party causes a fundamental breach of the Contract.</p> <p>57.2 Fundamental breaches of Contract shall include, but shall not be limited to, the following:</p> <ul style="list-style-type: none"> <li>a) the Contractor stops work for 28 days when no stoppage of work is shown on the current Program and the stoppage has not been authorized by the Project Manager;</li> <li>b) the Project Manager instructs the Contractor to delay the progress of the Works, and the instruction is not withdrawn within 28 days;</li> <li>c) the Employer or the Contractor is made bankrupt or goes into liquidation other than for a reconstruction or amalgamation;</li> <li>d) a payment certified by the Project Manager is not paid by the Employer to the Contractor within 84 days of the date of the Project Manager’s certificate;</li> <li>e) the Project Manager gives Notice that failure to correct a particular Defect is a fundamental breach of Contract and the Contractor fails to correct it within a reasonable period of time determined by the Project Manager;</li> <li>f) the Contractor does not maintain a Security, which is required;</li> <li>g) the Contractor has delayed the completion of the Works by the number of days for which the</li> </ul>

	<p>maximum amount of liquidated damages can be paid, as <b>defined in the PCC</b>; or</p> <p>h) if the Contractor, in the judgment of the Employer has engaged in Fraud and Corruption, as defined in paragraph 2.2 a of the Appendix A to the GCC, in competing for or in executing the Contract, then the Employer may, after giving fourteen (14) days written notice to the Contractor, terminate the Contract and expel him from the Site.</p>
	57.3 Notwithstanding the above, the Employer may terminate the Contract for convenience.
	57.4 If the Contract is terminated, the Contractor shall stop work immediately, make the Site safe and secure, and leave the Site as soon as reasonably possible.
	57.5 When either party to the Contract gives notice of a breach of Contract to the Project Manager for a cause other than those listed under GCC Sub-Clause 56.2 above, the Project Manager shall decide whether the breach is fundamental or not.
<b>58. Payment upon Termination</b>	<p>58.1 If the Contract is terminated because of a fundamental breach of Contract by the Contractor, the Project Manager shall issue a certificate for the value of the work done and Materials ordered less advance payments received up to the date of the issue of the certificate and less the percentage to apply to the value of the work not completed, as <b>specified in the PCC</b>. Additional Liquidated Damages shall not apply. If the total amount due to the Employer exceeds any payment due to the Contractor, the difference shall be a debt payable to the Employer.</p> <p>58.2 If the Contract is terminated for the Employer's convenience or because of a fundamental breach of Contract by the Employer, the Project Manager shall issue a certificate for the value of the work done, Materials ordered, the reasonable cost of removal of Equipment, repatriation of the Contractor's personnel employed solely on the Works, and the Contractor's costs of protecting and securing the Works, and less advance payments received up to the date of the certificate.</p>
<b>59. Property</b>	59.1 All Materials on the Site, Plant, Equipment, Temporary Works, and Works shall be deemed to be the property of the Employer if the Contract is terminated because of the

	Contractor's default.
<p><b>60. Release from Performance</b></p>	<p>60.1 If the Contract is frustrated by the outbreak of war or by any other event entirely outside the control of either the Employer or the Contractor, the Project Manager shall certify that the Contract has been frustrated. The Contractor shall make the Site safe and stop work as quickly as possible after receiving this certificate and shall be paid for all work carried out before receiving it and for any work carried out afterwards to which a commitment was made.</p>
<p><b>61. Suspension of Grant by GOI and/or State Government of Uttar Pradesh</b></p>	<p>61.1 In the event that the Government of India (GoI) and/or State Government of Uttar Pradesh suspends the grant to the Employer, from which part of the payments to the Contractor are being made:</p> <ul style="list-style-type: none"> <li>(a) The Employer is obligated to notify the Contractor of such suspension within 7 days of having received the GoI and/or State Government of Uttar Pradesh's suspension notice.</li> <li>(b) If the Contractor has not received sums due to it within the 28 days for payment provided for in Sub-Clause 40.1, the Contractor may immediately issue a 14-day termination notice.</li> </ul>

## Section IX - Particular Conditions of Contract

<b>A. General</b>	
<b>GCC 1.1 (c)</b>	The financing institution is: Government of India and State Government of Uttar Pradesh
<b>GCC 1.1 (q)</b>	The Employer is <i>CEO, Aligarh Smart City Limited.</i>
<b>GCC 1.1 (u)</b>	The In-tended Completion Date for the whole of the Works shall be <b>Six (06) Months</b> from the <b>date of signing the agreement.</b>
<b>GCC 1.1 (x)</b>	The Project Manager is <i>[as nominated by ASCL]</i>
<b>GCC 1.1 (z)</b>	The Site is located at Aligarh
<b>GCC 1.1 (cc)</b>	The Start Date shall be <b>As mentioned in LoA.</b>
<b>GCC 1.1 (gg)</b>	The work consists of Design, Manufacture, Supply, Installation and Commissioning of Different Capacity Roof Top Solar PV Power Projects under Net Metering Policy in Aligarh City (Smart City Mission)
<b>GCC 2.2</b>	Sectional Completions are: <i>Not Applicable</i>
<b>GCC 2.3(i)</b>	The following documents also form part of the Contract: Construction Schedule.
<b>GCC 3.1</b>	The language of the contract is <i>English.</i>  The law that applies to the Contract is the law of <i>India</i>
<b>GCC 5.1</b>	The Project manager <i>may</i> delegate any of his duties and responsibilities.
<b>GCC 8.1</b>	Schedule of other contractors: <i>None</i> , if obtained during the implementation period, the same shall be provided to the Contractor.
<b>GCC 9.1</b>	<b>Key Personnel</b> GCC 9.1 is replaced with the following:  Key Personnel are the Contractor's personnel named in this GCC 9.1 of the Particular Conditions of Contract. The Contractor shall employ the Key Personnel and use the equipment identified in its Bid, to carry out the Works or other personnel and equipment

	<p>approved by the Project Manager. The Project Manager shall approve any proposed replacement of Key Personnel and equipment only if their relevant qualifications or characteristics are substantially equal to or better than those proposed in the Bid.</p> <p>[insert the name/s of each Key Personnel agreed by the Employer prior to Contract signature.]</p>
<b>GCC 9.2</b>	<p><b>Code of Conduct (ESHS)</b></p> <p>The following is inserted at the end of GCC 9.2:</p> <p>“The reasons to remove a person include behavior which breaches the Code of Conduct (EHS) (e.g. spreading communicable diseases, sexual harassment, gender based violence, illicit activity or crime).”</p>
<b>GCC 13.1</b>	<p>The minimum insurance amounts and deductibles shall be:</p> <p>(a) for loss or damage to the Works, Plant and Materials: <i>Equal to the Contract Amount.</i></p> <p>(b) for personal injury or death:</p> <p>(i) of the Contractor’s employees: <i>INR 25 Lakh</i></p> <p>(ii) of other people: <i>In accordance with the statutory requirements applicable to India.</i></p>
<b>GCC 14.1</b>	Site Data are: None
<b>GCC 20.1</b>	The Site Possession Date(s) shall be: <i>as per the approved Programme</i>
<b>GCC 23.1 &amp; GCC 23.2</b>	Appointing Authority for the Adjudicator: <b><i>Will be finalised later as agreed mutually.</i></b>
<b>GCC 24.3</b>	Hourly rate and types of reimbursable expenses to be paid to the Adjudicator: shall be intimated later.
<b>GCC 24.4</b>	<p>The place of arbitration shall be: <b>Aligarh, India</b></p> <p><b>DISPUTES RESOLUTION MECHANISM</b></p> <p>(i) If any dispute or differences of any kind what-so-ever arise between the Employer, its authorized representatives and the contractor in connection with or arising out of this contract or the execution of work, these shall be resolved as under.</p> <p>(ii) Whether before its commencement or during the</p>

	<p>progress of Project/Work or after the termination, abandonment or breach of the contract, the dispute shall, in the first instance, be referred for settlement to the Project Manager of the work and he shall, within a period of sixty (60) days after being requested in writing by the contractor to do so, convey his decision to the contractor. Such decision in respect of every matter so referred shall, subject to arbitration as hereinafter provided, be final and binding upon the Contractor. In case the work is already in process, the contractor shall proceed with the execution of the work on receipt of the decision of the Project Manager as aforesaid with all due diligence, whether any of the parties requires arbitration as hereinafter provided or not.</p> <p>(iii) If the Project Manager has conveyed his decision to the contractor and no claim for arbitration has been filed by the contractor within a period of sixty (60) days from the receipt of the latter communicating the decision, the said decision shall be final and binding upon the contractor and will not be a subject matter of arbitration at all.</p> <p>(iv) If the Project Manager fails to convey his decision within a period of sixty days from the date on which the said request was made by the contractor, he may refer the dispute for arbitration as hereinafter provided.</p> <p>(v) All disputes or differences in respect of which the decision is not final and conclusive shall, at the request of either party made in communication sent through registered A.D. post, be referred for arbitration.</p> <p>(vi) The provisions of the Arbitration and Reconciliation Act, 1996 or any other statutory there under or modification thereof and for the time being in force shall apply to the arbitration proceedings under this clause.</p> <p>(vii) The Employer shall have the authority to change the arbitrator on an application by either the contractor or the Engineer requesting change of arbitrator giving reasons thereof, either before the start of the arbitration proceedings or during the course of such proceedings. The arbitration proceedings would stand suspended as soon as an application for change of Arbitrator is filed before the Employer and a notice thereof is given by the applicant to the Arbitrator. The Employer after hearing both the parties may pass a speaking order rejecting the application or accepting to change the arbitrator or</p>
--	--



	<p>simultaneously, appointing a technical officer as Arbitrator under the contract. The new arbitrator so appointed may enter upon the reference afresh or he may continue the hearings from the point these were suspended before the previous arbitrator.</p> <p>(viii) The reference to the arbitrator shall be made by the claimant party within one hundred twenty (120) days from the date of dispute of claim arises during the execution of work. If the claim pertains to rates or recoveries introduced in the final bill, the reference to the arbitrator shall be made within six calendar months from the date of payment of the final bill to the contractor or from the date a registered notice is sent to the contractor to the effect that his final bill is ready by the Engineer (whose decision in this respect shall be final and binding) whichever is earlier.</p> <p>(ix) It shall be an essential term of this contract that in order to avoid frivolous claims, the party invoking arbitration shall specify the disputes based upon facts and calculations stating the amount claimed under each claim and shall furnish a “deposit-at-call” for ten percent (10%) of the amount claimed, on a scheduled bank in the name of the Arbitrator, by his official designation who shall keep the amount in deposit till the announcement of the award. In the event of an award in favour of the claimant, the deposit shall be refunded to him in proportion to the amount awarded with respect to the amount claimed and the balance, if any, shall be forfeited and paid to the other party.</p> <p>(x) The Arbitrator/Arbitral Tribunal shall give a reasoned award for each claim/counter claim</p> <p>(xi) The independent claims of the party other than one seeking arbitration as also the counter claims of any party shall be entertained by the arbitrator.</p> <p>(xii) The work under the contract shall continue during the arbitration proceedings.</p> <p>(xiii) The stamp fee due on the award shall be payable by the party as desired by the Arbitrator/Arbitral Tribunal and in the event of such party’s default , the stamp fee shall recoverable from another sum due to such party under this or any other contract.</p>
--	--

	<p>(xiv) Neither party shall be entitled to bring a claim for arbitration, if it is not filed as per the time period already specified or within six (06) months of the following:-</p> <ul style="list-style-type: none"><li>a) of the date of completion of the work as certified by the Project manager or</li><li>b) of the date of abandonment of the work or breach of contract under any of its clauses, or</li><li>c) of its non-commencement or non-resumption of work within 10 days of written notice for commencement or resumption as applicable, or</li><li>d) of the cancellation, termination or withdrawal of the work from the contractor in whole or in part and/or revision for closure of the contract, or</li><li>e) Of receiving an intimation from the Project Manager that the final payment due or recover from the contractor had been determined, for the purpose of payment/adjustment whichever is the latest. If the matter is not referred to arbitration within the period prescribed above, all the rights and claims of either party under the contract shall be deemed to have been fortified and absolutely barred by the time for arbitration and even for civil litigation.</li></ul> <p>(xv) No question relating to this contract shall be brought before any civil court without first invoking and completing the arbitration proceedings, if the issue is covered by the scope of arbitration under the contract. The pending arbitration proceedings shall not disentitle the Project Manager to terminate the contract and to make alternate arrangement for completion of the works.</p> <p>(xvi) The Arbitrator/Arbitral Tribunal shall be deemed to have entered on the reference on the day, notice is issued to the parties fixing the first date of hearing. The arbitrator/Arbitral Tribunal may, from time to time, with the consent of the parties enlarge the initial time for making and publishing the award. However, Arbitrator/Arbitral Tribunal shall make all out efforts to decide each claim within a period of 6 months from the date of initiation.</p> <p>(xvii) The expiry to the contractual time limit, whether originally fixed or extended, shall not invalidate the provisions of this clause.</p>
--	--

<b>B. Time Control</b>	
<b>GCC 26.1</b>	The Contractor shall submit for approval a Program for the Works within 15 days from the date of the Letter of Acceptance.
<b>GCC 26.2</b>	<p><b>EHS Reporting</b></p> <p>Inserted at the end of GCC 26.2:</p> <p>“In addition to the progress report, the Contractor shall also provide a report on the Environmental, Health and Safety (EHS) metrics. In addition to Appendix A reports, the Contractor shall also provide immediate notification to the Project Manager of incidents in the following categories. Full details of such incidents shall be provided to the Project Manager within the timeframe agreed with the Project Manager.</p> <ul style="list-style-type: none"> <li>(h) confirmed or likely violation of any law or international agreement;</li> <li>(i) any fatality or serious (lost time) injury;</li> <li>(j) significant adverse effects or damage to private property (e.g. vehicle accident, damage from fly rock, working beyond the boundary)</li> <li>(k) major pollution of drinking water aquifer or damage or destruction of rare or endangered habitat (including protected areas) or species; or</li> <li>(l) any allegation of sexual harassment or sexual misbehaviour, child abuse, defilement, or other violations involving children.</li> </ul>
<b>GCC 26.3</b>	<p>The period between Program updates is 30 days.</p> <p>The amount to be withheld for late submission of an updated Program is Indian Rupees Two lakh Fifty Thousand only (INR2,50,000/-)</p>
<b>C. Quality Control</b>	
<b>GCC 34.1</b>	<p>The Defects Liability Period is: <i>1 year from the date of completion of work in all respect and issuance of the Completion Certificate.</i></p> <p>Add the following clause after clause 34.3</p>

	<p><b>Operation and maintenance:</b></p> <p>34.4 The operation and maintenance period is 5 year from the date of completion of Works as per schedule mentioned in section VII- Works Requirement.</p>
<p><b>D. Cost Control</b></p>	
<b>GCC 38.2</b>	<p>At the end of 38.2 add after the first sentence:</p> <p>“The Contractor shall also provide information of any EHS risks and impacts of the Variation.”</p>
<b>GCC 38.8</b>	<p>Variation</p> <ul style="list-style-type: none"> <li>• Extra items of work are Items, which are completely new and in addition to the items in contract.</li> <li>• Substituted items are items which are taken up in lieu of those already provided in the contract. These are with partial modification in items of work in the contract. If an agreement item is completely changed, the new time taken up in lieu of it is an Extra Item.</li> <li>• Wordings of extra/substituted items sanctioned by competent authorities should be properly formulated so as to reflect the exact mode of execution in the field.</li> <li>• No extra/substituted item should be executed without the prior approval of the authority who accorded the technical sanction.</li> <li>• Fixation of rates shall be made as per the provisions of the 38.2 38.3, 38.4 of GCC</li> </ul>
<b>GCC 38.7</b>	<p>If the value engineering proposal is approved by the Employer the amount to be paid to the Contractor shall be 5% (<i>five percent</i>) of the reduction in the Contract Price. The amount shall be paid after the completion of the project taking the final contract amount in consideration.</p>
<b>GCC 38.7</b>	<p>In the first paragraph insert new sub-paragraph (d):</p> <p>“(d) a description of the proposed work to be performed, a programme for its execution and sufficient EHS information to enable an evaluation of EHS risks and impacts;”</p>
<b>GCC 40</b>	<p>Add new GCC 40.8</p>

	<p>“40.8 The payment for the operation and maintenance shall be made quarterly on pro-rata basis. The Contractor shall submit the quarterly bill supported with requisite documents to the Project Manager mentioning the details of the operation and maintenance done during the quarter. The payment will be made by the Project Manager clause 41 of the G.C.C.”</p>
<b>GCC 44.1</b>	The currency of the Employer’s country is: <i>Indian Rupees.</i>
<b>GCC 45.1</b>	The Contract <i>is not</i> subject to price adjustment in accordance with GCC Clause 45.
<b>GCC 46.1</b>	The proportion of payments retained is: <i>5% (five Percent)]</i>
<b>GCC 47.1</b>	<p>The liquidated damages for the whole of the Works are <i>0.10 %</i> (zero point one percent) per day. The maximum amount of liquidated damages for the whole of the Works is <i>10% (ten percent)</i> of the final Contract Price.</p> <p>The Contractor shall ensure due diligence to achieve progress of work not less than that indicated in the following milestones:</p> <ul style="list-style-type: none"> <li>a) Lapse of 25% of the Contractual time- 10%</li> <li>b) Lapse of 50% of the Contractual time- 30%</li> <li>c) Lapse of 75% of the Contractual time- 65%</li> <li>d) Lapse of 100% of the Contractual time-100%</li> </ul> <p>In addition to the above, the works would be carried out and the ASCL would back charge the bidder along with a markup of 20% on the actual cost incurred to carry out the said work.</p>
<b>GCC 47</b>	<p>Add New GCC 47.3</p> <p>“Clause 47.3- In case of continued default or shortfall in progress, the Project Manager may go on further enhancing the levy of liquidated damages, each time limited to 1% of the amount of contract per week of further default subject to maximum limit of five (5) percent of the Contract value.</p>
<b>GCC 48.1</b>	Not Applicable
<b>GCC 49.1</b>	The Advance Payments shall be: <i>Ten percent (10%) against the unconditional irrevocable BG of 110% of the Value.</i>
<b>GCC 50.1</b>	The Performance Security amount is 5% of the Contract Amount. Additional performance security of 10% for the unbalanced bid.

<b>GCC 51</b>	Not Applicable
<b>E. Finishing the Contract</b>	
<b>GCC 56.1</b>	<p>The date by which operating and maintenance manuals are required is <i>30 days before the completion of the Contract period.</i></p> <p>The date by which “as built” drawings are required is <i>15 days after the completion of the Contract period or with the Final Bill whichever is earlier.</i></p>
<b>GCC 56.2</b>	The amount to be withheld for failing to produce “as built” drawings and/or operating and maintenance manuals by the date required in GCC 58.1 is <i>Indian Rupees 20.00 (twenty) Lakhs.</i>
<b>GCC 57.2 (g)</b>	The maximum number of days is 100 days.
<b>GCC 58.1</b>	The percentage to apply to the value of the work not completed, representing the Employer’s additional cost for completing the Works, is <i>20% (twenty percent).</i>

## Section X - Contract Forms

This Section contains forms which, once completed, will form part of the Contract. The forms for Performance Security and Advance Payment Security, when required, shall only be completed by the successful Bidder after contract award.

### Table of Forms

Letter of Acceptance .....	135
Contract Agreement .....	136
Performance Security - Bank Guarantee.....	138
Advance Payment Security .....	140
Indenture For Secured Advances .....	142

## NOTIFICATION OF AWARD

### Letter of Acceptance

*[on letterhead paper of the Employer]*

..... *[date]* .....

To: ..... *[ name and address of the Contractor]* .....

Subject: ..... *[Notification of Award Contract No.]* .....

This is to notify you that your Bid dated . . . . *[insert date]* . . . . for execution of the . . . .  
. . . . . *[insert name of the contract and identification number, as given in the PCC]* . .  
. . . . . for the Accepted Contract Amount of . . . . . *[insert amount in numbers  
and words and name of currency]*, as corrected and modified in accordance with the  
Instructions to Bidders is hereby accepted by Aligarh Smart City Limited(LSCL)..

You are requested to furnish the Performance Security within 28 days in accordance  
with the Conditions of Contract, using for that purpose the of the Performance Security  
Form included in Section X - Contract Forms, of the bidding document.

*[Choose one of the following statements:]*

We accept that \_\_\_\_\_ *[insert the name of Adjudicator  
proposed by the Bidder]* be appointed as the Adjudicator.

*[or]*

We do not accept that \_\_\_\_\_ *[insert the name of the Adjudicator  
proposed by the Bidder]* be appointed as the Adjudicator, and by sending a copy of this  
Letter of Acceptance to \_\_\_\_\_ *[insert name  
of the Appointing Authority]*, the Appointing Authority, we are hereby requesting such  
Authority to appoint the Adjudicator in accordance with ITB 50.1 and GCC 23.1.

Authorized Signature: .....

Name and Title of Signatory: .....

Name of Agency: .....

**Attachment: Contract Agreement**



## Contract Agreement

THIS AGREEMENT made the . . . . .day of . . . . ., . . . . ., between . . . . . Aligarh Smart City Limited (hereinafter “the Employer”), of the one part, and . . . . . *[name of the Contractor]*. . . . .(hereinafter “the Contractor”), of the other part:

WHEREAS the Employer desires that the Works known as . . . . . *[name of the Contract]*. . . . .should be executed by the Contractor, and has accepted a Bid by the Contractor for the execution and completion of these Works and the remedying of any defects therein,

The Employer and the Contractor agree as follows:

1. In this Agreement words and expressions shall have the same meanings as are respectively assigned to them in the Contract documents referred to.
2. The following documents shall be deemed to form and be read and construed as part of this Agreement. This Agreement shall prevail over all other Contract documents.
  - (a) the Letter of Acceptance
  - (b) the Letter of Bid Technical and Financial Parts
  - (c) the addenda Nos \_\_\_\_\_(if any)
  - (d) the Particular Conditions of Contract
  - (e) the General Conditions of Contract, including Appendices;
  - (f) the Specification
  - (g) the Drawings
  - (h) Bill of Quantities; and
  - (i) any other document **listed in the PCC** as forming part of the Contract;
3. In consideration of the payments to be made by the Employer to the Contractor as specified in this Agreement, the Contractor hereby covenants with the Employer to execute the Works and to remedy defects therein in conformity in all respects with the provisions of the Contract.
4. The Employer hereby covenants to pay the Contractor in consideration of the execution and completion of the Works and the remedying of defects therein, the Contract Price or such other sum as may become payable under the provisions of the Contract at the times and in the manner prescribed by the Contract.

IN WITNESS whereof the parties hereto have caused this Agreement to be executed in accordance with the laws of . . . . . [India]. . . . .on the day, month and year specified above.



Signed by: \_\_\_\_\_  
for and on behalf of the Employer

Signed by: \_\_\_\_\_  
for and on behalf the Contractor

in the  
presence of: \_\_\_\_\_  
Witness, Name, Signature, Address, Date

in the  
presence of: \_\_\_\_\_  
Witness, Name, Signature, Address, Date

## Performance Security - Bank Guarantee

*[Guarantor letterhead or SWIFT identifier code]*

**Beneficiary:** *[insert name and Address of Employer]*

**Date:** *\_ [Insert date of issue]*

**PERFORMANCE GUARANTEE No.:** *[Insert guarantee reference number]*

**Guarantor:** *[Insert name and address of place of issue, unless indicated in the letterhead]*

We have been informed that *\_ [insert name of Contractor, which in the case of a joint venture shall be the name of the joint venture]* (hereinafter called "the Applicant") has entered into Contract No. *[insert reference number of the contract]* dated *[insert date]* with the Beneficiary, for the execution of *\_ [insert name of contract and brief description of Works]* (hereinafter called "the Contract").

Furthermore, we understand that, according to the conditions of the Contract, a performance guarantee is required.

At the request of the Applicant, we as Guarantor, hereby irrevocably undertake to pay the Beneficiary any sum or sums not exceeding in total an amount of *[insert amount in figures]* (\_\_\_\_\_) *[insert amount in words]*,<sup>1</sup> such sum being payable in the types and proportions of currencies in which the Contract Price is payable, upon receipt by us of the Beneficiary's complying demand supported by the Beneficiary's statement, whether in the demand itself or in a separate signed document accompanying or identifying the demand, stating that the Applicant is in breach of its obligation(s) under the Contract, without the Beneficiary needing to prove or to show grounds for your demand or the sum specified therein.

This guarantee shall expire, no later than the .... Day of ....., 2...<sup>2</sup>, and any demand for payment under it must be received by us at this office indicated above on or before that date.

\_\_\_\_\_  
*[signature(s)]*

<sup>1</sup> *The Guarantor shall insert an amount representing the percentage of the Accepted Contract Amount specified in the Letter of Acceptance, less provisional sums, if any, and denominated either in the currency(cies) of the Contract or a freely convertible currency acceptable to the Beneficiary.*

<sup>2</sup> *Insert the date twenty-eight days after the expected completion date as described in GCC Clause 53.1. The Employer should note that in the event of an extension of this date for completion of the Contract, the Employer would need to request an extension of this guarantee from the Guarantor. Such request must be in writing and must be made prior to the expiration date established in the guarantee. In preparing this guarantee, the Employer might consider adding the following text to the form, at the end of the penultimate paragraph: "The Guarantor agrees to a one-time extension of this guarantee for a period not to exceed [six months][one year], in response to the Beneficiary's written request for such extension, such request to be presented to the Guarantor before the expiry of the guarantee."*

*Note: All italicized text (including footnotes) is for use in preparing this form and shall be deleted from the final product.*

## Advance Payment Security

### Demand Guarantee

*[Guarantor letterhead or SWIFT identifier code]*

**Beneficiary:** *[Insert name and Address of Employer]*

**Date:** *[Insert date of issue]*

**ADVANCE PAYMENT GUARANTEE No.:** *[Insert guarantee reference number]*

**Guarantor:** *[Insert name and address of place of issue, unless indicated in the letterhead]*

We have been informed that *[insert name of Contractor, which in the case of a joint venture shall be the name of the joint venture]* (hereinafter called “the Applicant”) has entered into Contract No. *[insert reference number of the contract]* dated *[insert date]* with the Beneficiary, for the execution of *[insert name of contract and brief description of Works]* (hereinafter called "the Contract").

Furthermore, we understand that, according to the conditions of the Contract, an advance payment in the sum *[insert amount in figures]* ( ) *[insert amount in words]* is to be made against an advance payment guarantee.

At the request of the Applicant, we as Guarantor, hereby irrevocably undertake to pay the Beneficiary any sum or sums not exceeding in total an amount of *[insert amount in figures]*/ ( \_\_\_\_\_ ) *[insert amount in words]*<sup>1</sup> upon receipt by us of the Beneficiary’s complying demand supported by the Beneficiary’s statement, whether in the demand itself or in a separate signed document accompanying or identifying the demand, stating either that the Applicant:

- (a) has used the advance payment for purposes other than the costs of mobilization in respect of the Works; or
- (b) has failed to repay the advance payment in accordance with the Contract conditions, specifying the amount which the Applicant has failed to repay.

A demand under this guarantee may be presented as from the presentation to the Guarantor of a certificate from the Beneficiary’s bank stating that the advance payment referred to above has been credited to the Applicant on its account number *[insert number]* at *[insert name and address of Applicant’s bank]*.

---

<sup>1</sup> *The Guarantor shall insert an amount representing the amount of the advance payment and denominated either in the currency(ies) of the advance payment as specified in the Contract, or in a freely convertible currency acceptable to the Employer.*

The maximum amount of this guarantee shall be progressively reduced by the amount of the advance payment repaid by the Applicant as specified in copies of interim statements or payment certificates which shall be presented to us. This guarantee shall expire, at the latest, upon our receipt of a copy of the interim payment certificate indicating that ninety (90) percent of the Accepted Contract Amount, less provisional sums, has been certified for payment, or on the [insert day] day of [insert month], 2 [insert year],<sup>2</sup> whichever is earlier. Consequently, any demand for payment under this guarantee must be received by us at this office on or before that date.

---

[signature(s)]

***Note: All italicized text (including footnotes) is for use in preparing this form and shall be deleted from the final product.***

---

<sup>2</sup> *Insert the expected expiration date of the Time for Completion. The Employer should note that in the event of an extension of the time for completion of the Contract, the Employer would need to request an extension of this guarantee from the Guarantor. Such request must be in writing and must be made prior to the expiration date established in the guarantee. In preparing this guarantee, the Employer might consider adding the following text to the form, at the end of the penultimate paragraph: “The Guarantor agrees to a one-time extension of this guarantee for a period not to exceed [six months][one year], in response to the Beneficiary’s written request for such extension, such request to be presented to the Guarantor before the expiry of the guarantee.”*

## Indenture For Secured Advances

*(For use in cases in which the contract is for finished work and the Contractor has entered into an agreement for the execution of a certain specified quantity of work in a given time)*

This indenture made the day of \_\_\_\_\_, 20 \_\_\_\_ BETWEEN \_\_\_\_\_ (hereinafter called the Contractor which expression shall where the context so admits or implies be deemed to include his executors, administrators and assigns) or the one part and Employer of the other part.

Whereas by an agreement dated \_\_\_\_\_ (hereinafter called the said agreement) the Contractor has agreed.

AND WHEREAS the Contractor has applied to the Employer that he may be allowed advanced on the security of materials absolutely belonging to him and brought by him to the site of the works the subject of the said agreement for use in the construction of such of the works as he has undertaken to executive at rates fixed for the finished work (inclusive of the cost of materials and labour and other charges).

AND WHEREAS the Employer has agreed to advance to the Contractor the sum of Rupees on the security of materials the quantities and other particulars of which are detailed in Accounts of Secured Advances attached to the Running Account bill for the said works signed by the Contractor on and the Employer has reserved to himself the option of making any further advance or advances on the security of other materials brought by the Contractor to the site of the said work.

NOW THIS INDENTURE WITNESSETH that in pursuance of the said agreement and in consideration of the sum of Rupees \_\_\_\_\_ on or before the execution of these presents paid to the Contractor by the Employer (the receipt where of the Contractor doth hereby acknowledge) and of such further advances (if any) as may be made to him as a for said the Contractor doth hereby covenant and agree with the President and declare as follows:

1. That the said sum of Rupees so advanced by the Employer to the Contractor as aforesaid and all or any further sum of sums advanced as aforesaid shall be employed by the Contractor in or towards expending the execution of the said works and for no other purpose whatsoever.
2. That the materials details in the said Account of Secured Advances which have been offered to and accepted by the Employer as security are absolutely the Contractor's own propriety and free from encumbrances of any kind and the Contractor will not make any application for or receive a further advance on the security of materials which are not absolutely his own property and free from encumbrances of any kind and the Contractor indemnified the Employer against all claims to any materials in respect of which an advances has be made to him as aforesaid.
3. That the materials detailed in the said account of Secured Advances and all other materials on the security of which any further advance or advances may hereafter be

made as aforesaid (hereafter called the said materials) shall be used by the Contractor solely in the execution of the said work in accordance with the directions of the project Manager.

4. That the Contractor shall make at his own cost all necessary and adequate arrangements for the proper watch, safe custody and protection against all risks of the said materials and that until used in construction as aforesaid the said materials shall remain at the site of the said works in the Contractor's custody and on his own responsibility and shall at all times be open to inspection by the Project Manager or any officer authorized by him.

In the event of the said materials or any part thereof being stolen, destroyed or damaged or becoming deteriorated in a greater degree than is due to reasonable use and wear thereof the Contractor will forthwith replace the same with other materials of like quality or repair and make good the same required by the Project Manager.

5. That the said materials shall not be any account be removed from the site of the said works except with the written permission of the Project Manager or an officer authorized by him on that behalf.
6. That the advances shall be repayable in full when or before the Contractor receives payment from the Employer of the price payable to him for the said works under the terms and provisions of the said agreement. Provided that if any intermediate payments are made to the Contractor on account of work done than on the occasion of each such payment the Employer will be a liberty to make a recovery from the Contractor's bill for such payment by deducting there from the value of the said materials than actually used in the construction and in respect of which recovery has not been made previously, the value for this purpose being determined in respect of each description of materials at the rates at which the amounts of the advances made under these presents were calculated.
7. That if the Contractor shall at any time make any default in the performance or observance in any respect of any of the terms and provisions of the said agreement or of these presents the total amount of the advance or advances that may still be owing of the Employer shall immediately on the happening of such default be repayable by the Contractor to be the Employer together with interest thereon at twelve per cent (12%) per annum from the date or respective dates of such advance or advances to the date of repayment and with all costs, charges, damages and expenses incurred by the Employer in or for the recovery thereof or the enforcement of this security or otherwise by reason of the default of the Contractor and the Contractor hereby covenants and agrees with the Employer to reply and pay the same respectively to him accordingly.
8. That the Contractor hereby charges all the said materials with the repayment to the Employer of the said sum of Rupees and any further sum of sums advanced as aforesaid and all costs, charges, damages and expenses payable under these presents PROVIDED ALWAYS and it is hereby agreed and declared that notwithstanding anything in the said agreement and without prejudice to the power contained therein if and whenever the covenant for payment and repayment here-in- before contained shall become enforceable and the money owing shall not be paid in accordance there with the Employer may at any time thereafter adopt all or any of the following courses as he may deem best:



- 
- a. Seize and utilize the said materials or any part thereof in the completion of the said works on behalf of the Contractor in accordance with the provisions in that behalf contained in the said agreement debiting the Contractor with the actual cost of effecting such completion and the amount due to the Contractor with the value of work done as if he had carried it out in accordance with the said agreement and at the rates thereby provided. If the balance is against the Contractor, he is to pay same to the Employer on demand.
  - b. Remove and sell by public auction the seized materials or any part thereof and out of the moneys arising from the sale retain all the sums aforesaid repayable or payable to the Employer under these presents and pay over the surplus (if any) to the Contractor.
  - c. Deduct all or any part of the moneys owing out of the security deposit or any sum due to the Contractor under the said agreement.
9. That except in the event of such default on the part of the Contractor as aforesaid interest on the said advance shall not be payable.
  10. That in the event of any conflict between the provisions of these presents and the said agreement the provisions of these presents shall prevail and in the event of any dispute or difference arising over the construction or effect of these presents the settlement of which has not been here-in-before expressly provided for the same shall be referred to the Employer whose decision shall be final and the provision of the Indian Arbitration Act for the time being in force shall apply to any such reference.