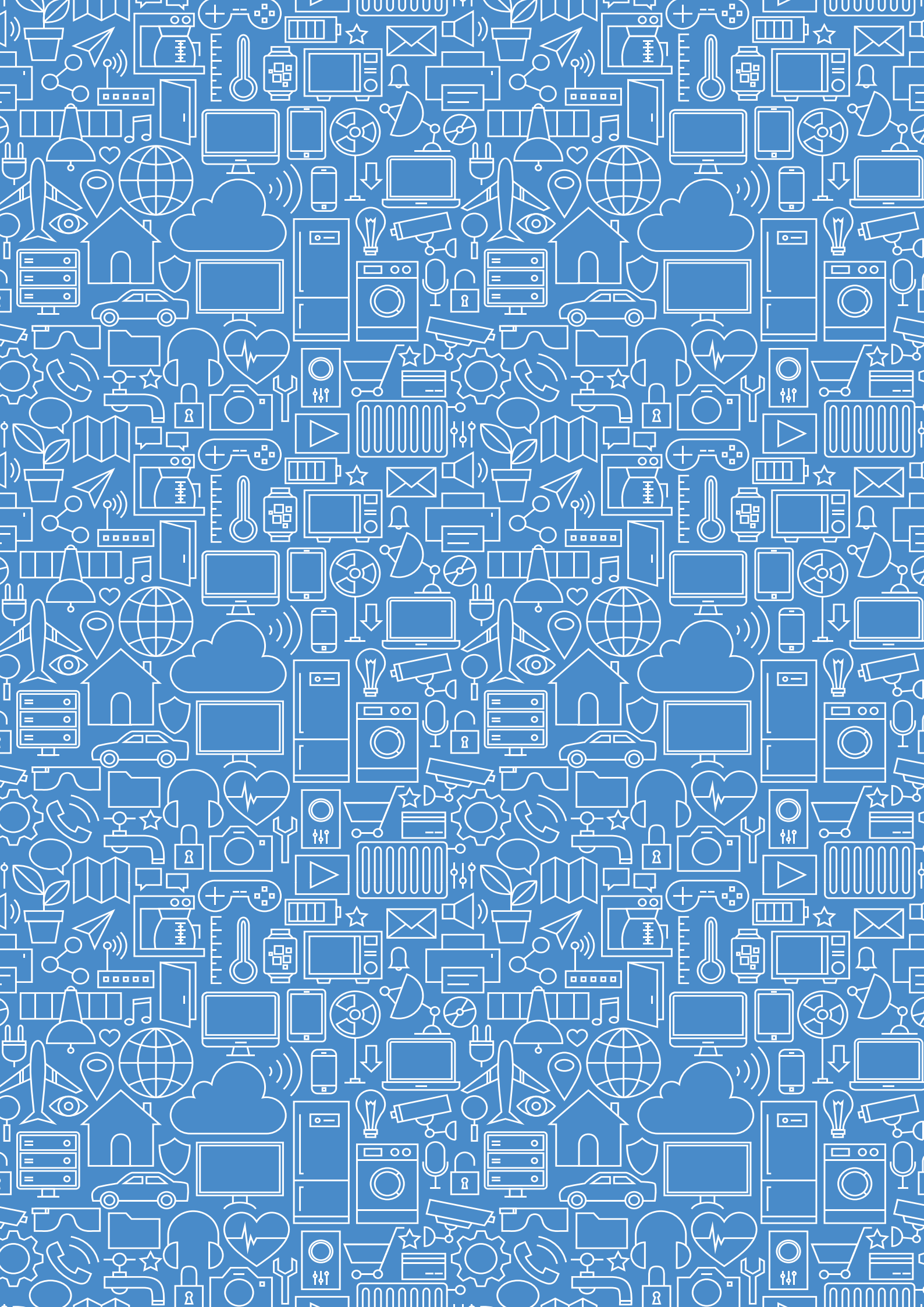




SMART SUSTAINABLE CITY

# Shaping smarter and more sustainable cities

*Striving for sustainable development goals*





# Shaping smarter and more sustainable cities

*Striving for sustainable  
development goals*















# FOREWORD

The ITU-T Focus Group on Smart Sustainable Cities (FG-SSC) concluded its two-year study in May 2015 with the delivery of 21 Technical Reports and Specifications to provide the foundations of subsequent ITU-T standardization work. This compendium of the reports and specifications released by the Focus Group will assist the studies of all decision-makers with smart-city ambitions.

Smart Sustainable Cities will contribute to the achievement of the Sustainable Development Goals by leveraging information and communication technologies (ICTs) to set cities on a development course characterized by environmental sustainability, resilience, and equitable social and economic growth.

The ITU-T Focus Group on Smart Sustainable Cities encouraged collaboration among the many stakeholders expected to contribute to the development of Smart Sustainable Cities. The diverse group analyzed research on the topic of smart cities, addressing gaps in research and establishing a basis for the development of relevant international standards.

Smart Sustainable Cities require trusted information infrastructure capable of supporting an enormous volume and diversity of ICT applications and citizen-driven services. The foundational ICT infrastructure of a smart city should ensure openness and interoperability, achieved with coordinated adherence to common standards.

In June 2015, ITU members established the new ITU-T Study Group 20 to look at “Internet of Things and its applications including smart cities and communities”. ITU-T Study Group 20 is taking an innovative approach to IoT standardization by placing ITU’s technical expertise at the service of national and local governments, city planners and a wide range of vertical industries. We have also partnered with Dubai and Singapore in a two-year trial of ITU’s



key performance indicators for Smart Sustainable cities, and we are in discussion with other cities interested in following suit.

The development of Smart Sustainable Cities will require national and local governments to work in collaboration with industry and society to develop processes for more integrated decision-making. ITU-T Study Group 20 and the trial implementation of the key performance indicators are examples of new models of collaboration to improve the coordination of smart-city development.

I trust that this compendium will provide a valuable reference point to the community driving the development of Smart Sustainable Cities. The Focus Group was successful in encouraging the collaboration of smart-city stakeholders, and this compendium is expected to play a similar role in building a common understanding of stakeholders’ respective responsibilities in the development of Smart Sustainable Cities.

A handwritten signature in blue ink, consisting of stylized, overlapping loops and lines.

Chaesub Lee  
Director, ITU Telecommunication  
Standardization Bureau





# TABLE OF CONTENTS

<b>1</b>	<b>Introduction</b>	<b>01</b>
<b>2</b>	<b>Empowering Smart Sustainable City Transitions</b>	<b>05</b>
2.1	An overview of smart sustainable cities and the role of information and communication technologies – (technical report)	07
2.2	Smart Sustainable Cities: an analysis of definitions – (technical report)	47
2.3	Smart sustainable cities: a guide for city leaders- (technical report)	125
2.4	Master plan for smart sustainable cities- (technical report)	135
2.5	Setting the stage for stakeholders’ engagement in smart sustainable cities – (technical report)	169
<b>3</b>	<b>Exploring the Smart Sustainable City Infrastructure</b>	<b>213</b>
3.1	Overview of smart sustainable cities infrastructure- (technical report)	215
3.2	Setting the framework for an ICT architecture of a smart sustainable city- (technical specifications)	337
3.3	Multi-service infrastructure for smart sustainable cities in new-development areas - (technical specifications)	383
3.4	Cybersecurity, data protection and cyber resilience in smart sustainable cities – (technical report)	421
3.5	Intelligent sustainable buildings for smart sustainable cities- (technical report)	453
3.6	Smart water management in cities – (technical report)	497
3.7	Information and communication technologies for climate change adaptation in cities – (technical report)	543
3.8	Electromagnetic field (EMF) considerations in smart sustainable cities – (technical report)	585
3.9	Integrated management for smart sustainable cities – (technical report)	649
3.10	Anonymization infrastructure and open data in smart sustainable cities- (technical report)	683
<b>4</b>	<b>Metrics for Measuring Smart Sustainable City Transitions</b>	<b>753</b>
4.1	Overview of key performance indicators in smart sustainable cities – (technical specifications)	755
4.2	Key performance indicators related to the use of information and communication technology in smart sustainable cities – (technical specifications)	771
4.3	Key performance indicators related to the sustainability impacts of information and communication technology in smart sustainable cities – (technical specifications)	795
4.4	Key performance indicators definitions for smart sustainable cities – (technical report)	817
<b>5</b>	<b>Paving the way for SSC</b>	<b>919</b>
5.1	Standardization roadmap for smart sustainable cities – (technical report)	921
5.2	Standardization activities for smart sustainable cities- (technical report)	957
<b>6</b>	<b>Conclusion</b>	<b>1105</b>





# INTRODUCTION

The development of Smart Sustainable Cities is at the heart of our pursuit of sustainability. Modern cities are responsible for 80 per cent of global economic output and 70 per cent of global energy consumption and GHG emissions, and, by year 2050, cities will be home to 66 per cent of the world's projected 9 billion inhabitants.

The ITU-T Focus Group on Smart Sustainable Cities was established as an open platform for smart-city stakeholders – such as municipalities; academic and research institutes; non-governmental organizations (NGOs); and ICT organizations, industry forums and consortia – to exchange knowledge in the interests of identifying the standardized frameworks needed to support the integration of ICT services in smart cities.

ITU collaboration with UN Economic Commission for Europe (UNECE), within the framework provided by the ITU-T Focus Group on Smart Sustainable Cities, led to the international agreement of a definition of Smart Sustainable Cities:

“A smart sustainable city (SSC) is an innovative city that uses information and communication technologies (ICTs) and other means to improve quality of life, efficiency of urban operation and services, and competitiveness, while ensuring that it meets the needs of present and future generations with respect to economic, social, environmental as well as cultural aspects”.

This compendium of the 21 Technical Reports and Specifications developed by the Focus Group provides an overview of how ICTs could be deployed with traditional infrastructures to promote the coordinated, integrated use of new digital technologies in meeting 21st Century urban-development objectives.

In September 2015, the United Nations General Assembly achieved consensus on a new set of 17 Sustainable Development Goals, adopting a global sustainable development agenda, applicable to both developed and developing countries.

ICTs play an important role in this agenda, in particular as part of Goal 9 – Build resilient infrastructure, promote inclusive and sustainable industrialization and foster innovation – which includes a target to increase access to ICTs and provide universal and affordable access to the Internet. Addressing urban development more directly, Goal 11 – Make cities and human settlements inclusive, safe, resilient

and sustainable – encourages cities to adopt integrated policies and plans to build more inclusive, resource-efficient cities able to mitigate and adapt to climate change and improve their resilience to disasters. The promotion of Smart Sustainable Cities will be key to achieving these objectives, in addition serving the overarching objective outlined by Goal 13, to “Take urgent action to combat climate change and its impacts”.

The new ITU-T Study Group 20 is developing international standards to enable the coordinated development of the Internet of Things (IoT), including machine-to-machine communications and ubiquitous sensor networks. The Study Group will develop standards that leverage IoT to address urban-development challenges, building on the 21 Technical Reports and Specifications compiled by this compendium.

The Technical Reports and Specifications outline feasible means of developing Smart Sustainable Cities. They provide guidance to city leaders in establishing a framework for the management, control and optimization of the Smart Sustainable City environment as a laboratory for innovation and urban simulation. Such frameworks help us to improve our understanding of existing urban challenges as a basis for the development of effective responses to these challenges using coordinated urban ICT systems.

This compendium also provides a detailed list of the key performance indicators (KPIs) for Smart Sustainable Cities developed by the Focus Group to assist city leaders in evaluating their degree of success in achieving the objectives of smart-city strategies. Dubai and Singapore were the first two cities to join ITU’s two-year pilot project to evaluate the feasibility of the KPIs, and ITU has been approached by a range of other cities interesting in joining the project. The pilot project will contribute to ITU’s international standardization of the indicators and the subsequent development of a ‘Global Smart Sustainable Cities Index’ derived from this set of indicators.

This compendium is part of ITU’s efforts to support city leaders in their efforts to improve their understanding of the capabilities of Smart Sustainable Cities and the urban-development challenges motivating their development. ITU is committed to assisting cities in defining and executing long-term strategies for the development of Smart Sustainable Cities, and we are pleased to present this compendium in service of this commitment.











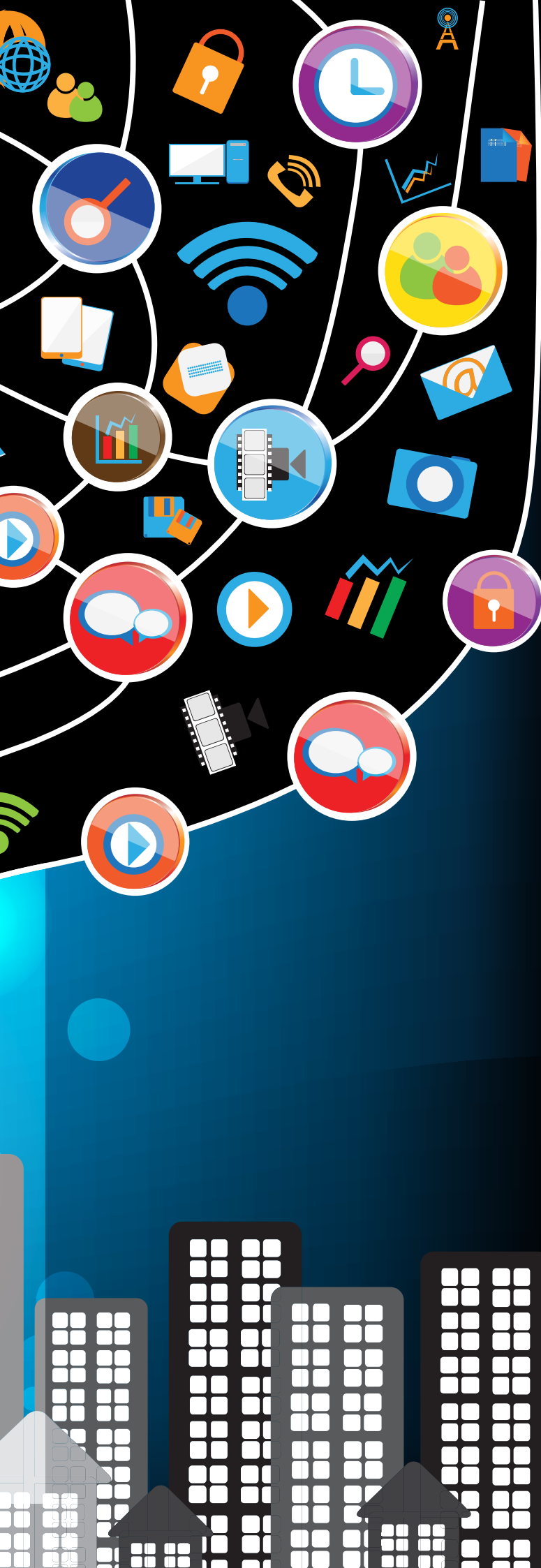
EMPOWERING  
SMART SUSTAINABLE  
CITY TRANSITIONS

2









# 2.1

**An overview of smart sustainable cities and the role of information and communication technologies**

**Technical Report**

## Acknowledgements

This Technical Report was researched and principally authored by Professor Sekhar N. Kondepudi from the National University of Singapore (NUS). The author would like to first thank ITU for providing such an exciting opportunity to work and research under the ITU-T Focus Group on Smart Sustainable Cities (FG-SSC). Vinod Ramanarayanan, Alok Jain, Guru Nandan Singh, Nitin Agarwal NK, Rahul Kumar and Rahul Singh (National University of Singapore), Pernilla Bergmark (Ericsson), Takafumi Hashitani (Fujitsu), Paolo Gemma (Huawei), Ziqin Sang (Fiberhome Technologies), Daniela Torres (Telefonica), Mythili Menon (University of Geneva), Angelica V. Ospina (University of Manchester) and Chris Ip (University of Toronto) provided inputs for this Technical Report.

The author also acknowledges the guidance and support from all the members of the ITU-T FG-SSC Management Team, and especially, Paolo Gemma (Huawei and FG-SSC Working Group 2 Coordinator).

Additional information and materials relating to this Technical Report can be found at: [www.itu.int/itu-t/climatechange](http://www.itu.int/itu-t/climatechange). If you would like to provide any additional information, please contact Cristina Bueti (ITU) at [tsbsg5@itu.int](mailto:tsbsg5@itu.int).



## Table of Contents

		Page
<b>1</b>	<b>Introduction .....</b>	<b>12</b>
1.1	Scope .....	12
1.2	Smart sustainable city: Concept and goals.....	13
1.3	ITU-T Focus group on smart sustainable cities.....	13
<b>2</b>	<b>City dimensions and attributes .....</b>	<b>14</b>
2.1	Environment and sustainability .....	15
2.2	City level services.....	16
2.3	Quality of life .....	17
2.4	Summary.....	18
<b>3</b>	<b>ICT, infrastructure and disasters in SSC.....</b>	<b>19</b>
3.1	The role of ICT in smart city solutions .....	20
3.2	Physical and service infrastructure elements .....	23
3.3	ICT infrastructure.....	29
3.4	Emergency/disaster response mechanisms.....	34
<b>4</b>	<b>Conclusions .....</b>	<b>35</b>
	<b>Glossary .....</b>	<b>38</b>
	<b>Bibliography .....</b>	<b>40</b>
	<b>Annex 1 – Smart city dimensions and attributes .....</b>	<b>43</b>



# Innovative solutions for Urban Improvement





## An overview of smart sustainable cities and the role of information and communication technologies

### Executive summary

This Technical Report describes the main attributes of a smart sustainable city (SSC) and provides readers with a better understanding of what constitutes SSC. It identifies the role and potential of information and communication technologies (ICTs) in SSC, and outlines at a high level the key ICT infrastructures which will enable SSC strategies.

Economy, governance, environment and society are the four primary pillars which characterize a city. These are reflected via three overarching dimensions of a city: (1) environment and sustainability, (2) city level services and (3) quality of life. Each of these dimensions have multiple attributes which characterize them, some of which overlap. Sustainability and the environment are critical to the urban landscape since cities represent 75% of energy consumption and 80% of CO<sub>2</sub> emissions on a global basis. The primary attributes in this dimension include infrastructure and governance, energy and climate change, pollution, waste, social, economic and health aspects. As for city level services, the key attributes include technology and infrastructure (e.g. transportation, buildings, healthcare), sustainability (e.g. water, air, waste), governance (e.g. organization, administration and leadership) and economy (e.g. financial, human capital, economic strength). The final dimension is the quality of life of the citizens. This reflects how the inhabitants of a city perceive their own sense of well-being and the fact that they are constantly striving to better themselves – for example, in terms of wealth, health and education. All of the above need to be balanced for a successful smart sustainable city.

Infrastructure is a pivotal aspect of a smart sustainable city. Traditionally, there have been two types of infrastructure: physical (e.g. buildings, roads, transportation, and power plants) and digital (information technology (IT) and communications infrastructure). There is also the concept of a service infrastructure which provides services which run on top of the physical infrastructure (e.g. education, health care, e-government, and mass transit). The digital infrastructure provides the glue to enable the smart sustainable city to operate efficiently and in an optimal manner.

Common physical and service infrastructures include: (1) smart energy, (2) smart buildings, (3) smart transportation, (4) smart water, (5) smart waste, (6) smart physical safety and security, (7) smart health care and (8) smart education.

ICT has a crucial role in SSC since it acts as the platform to aggregate information and data to help enable an improved understanding on how the city is functioning in terms of resource consumption, services, and lifestyles. Examples of what ICT can achieve include: (1) ICT-enabled information and knowledge sharing, (2) ICT-enabled forecasts and (3) ICT-enabled integration. Data prediction, analytics, big data, open data, Internet of things (IoT), data accessibility and management, data security, mobile broadband, ubiquitous sensor networks, all become essential in SSC and are predicated on a solid ICT infrastructure.

Therefore, a smart sustainable city has an end goal to achieve an economically sustainable urban environment without sacrificing the comfort and convenience/quality of life of citizenry. It strives to create a sustainable living environment for all its citizens through the use of information and communication technologies (ICTs).

# 1 Introduction

---

In the last 50 years, the world population has grown exponentially at an average rate of 1.2% per year. In 2007, for the first time in the history of mankind, the number of people living in cities surpassed the number of people living in rural areas. It is estimated that the proportion will exceed 70% by 2050. As the UN World Economic and Social Survey 2013<sup>1</sup> suggested, Africa, Asia, and other developing regions will be housing an estimate of 80% of the world's urban population in the coming years. In the period from 1950 to 2010, small cities saw a net increase of 1.3 billion people, while medium cities (632 million) and large cities (570 million) saw about half as much growth<sup>1</sup>.

Given the avenues of socio-economic development that urban areas have to offer, migration to urban cities has become synonymous to opportunities and prosperity for millions of people around the world. As a result, urban areas are getting more and more congested. Along with the associated natural population growth, local and national policies, and environmental changes, urban migration and congestion are expected to be continuous trends.

While urbanization brings advantages, it also brings challenges. Rapid urbanization adds pressure to the resource base, and increases demand for energy, water, and sanitation, as well as for public services, education and health care. Consequently, social, economic and environmental issues have become tightly interconnected. Cities greatly contribute to environmental degradation on local, regional, and global scales. Studies have demonstrated that they are accountable for 70% of global greenhouse gas emissions as well as 60-80%<sup>2</sup> of global energy consumption<sup>3</sup>.

The obvious question is: how can cities be made sustainable under such underlying conditions?

The answer lies in making cities 'smarter' by efficient management of resources and infrastructure, greener environment, and smart governance resulting in a better quality of living of its citizens. All of which can be enabled by the effective use of information and communication technologies (ICTs).

ICT tools have the ability to provide eco-friendly and economically viable solutions for cities. Potential advancements could be made in the forms of efficient water management based on real-time information exchanges, public transport systems organized through information gathered by satellites, exploring solutions to concerns related to air quality monitoring and electromagnetic fields, among others. This is where the concept of smart sustainable city comes into play.

## 1.1 Scope

Despite the wide range of literature that exists on the topic of global smart cities, there is a lack of agreement on the definition and on the specific parameters that characterize a smart sustainable city. Therefore, a comprehensive view of SSCs is vital to foster the consensus and consistency needed to advance the articulation of strategies, practice and research in this field.

In response to that need, this Technical Report seeks to: (1) provide an overview of the main attributes that make cities smart and sustainable, (2) explore the role and potential of ICTs within

---

<sup>1</sup> [http://www.un.org/en/development/desa/policy/wess/wess\\_current/wess2013/WESS2013.pdf](http://www.un.org/en/development/desa/policy/wess/wess_current/wess2013/WESS2013.pdf)

<sup>2</sup> [http://www.unhabitat.org/downloads/docs/E\\_Hot\\_Cities.pdf](http://www.unhabitat.org/downloads/docs/E_Hot_Cities.pdf)

<sup>3</sup> <http://www.un.org/en/sustainablefuture/cities.shtml>



SSCs, and (3) acknowledge, at a general level, the key ICT infrastructure needed to enable SSC strategies<sup>4</sup>.

The intended audience of this Technical Report are stakeholders and members of the general public interested in gaining a better understanding of what constitutes a smart sustainable city, and what its main attributes are.

This Technical Report is not intended as a recommendation document for best practices, but rather as a general foundation for further, more in-depth explorations of specific topics on a smart sustainable city. It aims to provide the reader with a broad overview of issues that are the forefront of the notion of a smart sustainable city, while setting the stage for additional detailed technical reports which are part of the mandate of the ITU-T Focus Group on Smart Sustainable Cities (FG-SSC).

## 1.2 Smart sustainable city: Concept and goals

In October 2015, ITU-T's Study Group 5 "Environment and Climate Change" and UNECE agreed on the following definition of a smart sustainable city based on the work carried out by ITU-T Focus Group on Smart Sustainable Cities:

*"A Smart Sustainable city (SSC) is an innovative city that uses information and communication technologies (ICTs) and other means to improve quality of life, efficiency of urban operation and services, and competitiveness, while ensuring that it meets the needs of present and future generations with respect to economic, social, environmental as well as cultural aspects".*

Linked to this definition, the main goal for SSC is to enhance the quality of life of its citizens across multiple, interrelated dimensions, including (but not limited to) the provision and access to water resources, energy, transportation and mobility, education, environment, waste management, housing and livelihoods (e.g. jobs), utilizing ICTs as the key medium.

Despite the enormous potential embedded in the goals of SSC, it is important to acknowledge the existence of challenges associated to global urbanization, urban migration trends, environmental degradation, climate change impacts, aging infrastructure, as well as constraints in the resources and structures needed to respond to a growing demand in settlement areas, among many others.

Within these increasingly complex urban systems, ICTs can act as a platform to help overcome these challenges and take advantage of emerging opportunities, as cities advance in the process towards becoming smart and sustainable.

## 1.3 ITU-T Focus group on smart sustainable cities

ITU-T Study Group 5 (ITU-T SG5) is working on tackling environmental and climate change issues including the development of a methodology to assess the environmental impact related to ICT in cities. As part of this effort, a Focus Group on Smart Sustainable Cities<sup>5</sup> (FG-SSC) was established in February 2013 by ITU-T Study Group 5.

<sup>4</sup> This topic is addressed in detail in the Technical Report on SSC Infrastructure, produced by ITU-T FG-SSC Working Group 2.

<sup>5</sup> <http://www.itu.int/en/ITU-T/focusgroups/ssc/Pages/default.aspx>

The Focus Group has four (4) main working groups (WG):

- WG1 – ICT role and roadmap for smart sustainable cities
- WG2 – ICT infrastructure
- WG3 – Standardization gaps, key performance indicators (KPIs) and metrics
- WG4 – Policy and positioning (communications, liaisons and members)

This Technical Report is part of the research and analysis for the Focus Group on Smart Sustainable Cities as a working document from WG1.

FG-SSC has coordinated a series of open meetings with the participation of multiple stakeholders involved in the design and implementation of SSC initiatives around the globe, including telecommunications companies, ICT companies, governments and academia, which provide the Focus Group with diverse perspectives and a broad base of information.

FG-SSC will play a key role in fostering a platform where various stakeholders can share views, develop sets of deliverables, and showcase initiatives, projects, policies, and standards. The Focus Group will also analyse ICT solutions and projects that promote environmental sustainability in cities. Best practices will then be identified from these experiences in order to facilitate and inform the implementation of new solutions in cities, and to be standardized by ITU-T SG5.

The Focus Group will develop a standardization roadmap taking into consideration the activities currently undertaken by the various standards development organizations (SDOs) and forums. The Focus Group is also working with non ITU-T members, leveraging the role of the ICT sector to foster the growth of smart and sustainable cities worldwide<sup>6</sup>.

## 2 *City dimensions and attributes*

---

To begin, the notion of a 'Smart and Sustainable City' entails more than just the implementation of technologies and strategies aimed at meeting today's needs without compromising those of future generations. It is also about understanding the city itself: its identity and its goals, its stakeholders and their priorities, and in that way, identifying the attributes that would tailor to the uniqueness of each city while enhancing its overall living quality and sustainability with the support of ICTs.

This section provides an overview of the key attributes that characterize cities, thus setting the basis for identifying the role of ICTs within the SSC context (section 3). Annex 1 provides some additional background and description for some of these dimensions and attributes.

Broadly speaking, there are three overarching and closely interrelated dimensions at the core of a city:

- a. environment and sustainability
- b. city level services
- c. quality of life

Each of these dimensions, and the attributes that characterize them, will be explored in further detail.

---

<sup>6</sup> [http://www.itu.int/en/ITU-T/focusgroups/ssc/Documents/ToR\\_FG%20SSC.docx](http://www.itu.int/en/ITU-T/focusgroups/ssc/Documents/ToR_FG%20SSC.docx)

## 2.1 Environment and sustainability

Cities represent 75% of energy consumption and 80% of CO<sub>2</sub> emissions on a global basis, and represent the largest of any environmental policy challenge<sup>7</sup>. Therefore, sustainability and the environment are the most critical components in the functioning of any city.

There is a clear distinction between the two terms (i.e. sustainability and the environment) that needs to be made. According to the [Brundtland Commission](#), sustainable development refers to the environmental, economic and social aspects, whereas environmental aspects refer to the physical and biological surroundings of a city.

The major attributes included under this dimension are the following:

- city infrastructure and governance
- energy and climate change
- pollution and waste
- social, economy and health

Multiple studies conducted in this field suggest that each of these attributes encompasses a series of more granular categories and components, as described below<sup>8 9 10 11 12 13</sup>.

**Table 1 – Categories and components of the environment and sustainability dimension**

City infrastructure and governance	
Policy and management	Infrastructure
<ul style="list-style-type: none"> <li>▪ Integrated environmental management</li> <li>▪ Strategy</li> <li>▪ Municipal administration</li> <li>▪ Effective conservation</li> </ul>	<ul style="list-style-type: none"> <li>▪ Urban planning</li> <li>▪ Buildings and physical infrastructure</li> <li>▪ Mobility, transportation and traffic</li> <li>▪ Public safety</li> </ul>
Energy and climate change	
CO <sub>2</sub> emissions	Energy
<ul style="list-style-type: none"> <li>▪ CO<sub>2</sub> from energy production</li> <li>▪ Emissions per capita</li> </ul>	<ul style="list-style-type: none"> <li>▪ Energy performance</li> <li>▪ Conservation</li> </ul>

<sup>7</sup> <http://www.theguardian.com/sustainable-business/smart-cities-innovation-energy-sustainable>

<sup>8</sup> Esty D.C., Levy M.A., Kim C.H., de Sherbinin A., Srebotnjak T., Mara V. (2008). 2008 Environmental Performance Index. New Haven: Yale Center for Environmental Law and Policy.

<sup>9</sup> <http://ec.europa.eu/environment/europeangreencapital/applying-for-the-award/evaluation-process/index.html#sthash.QXukMUww.dpuf>

<sup>10</sup> IBM smart cities web site  
[http://www.ibm.com/smarterplanet/us/en/smarter\\_cities/overview/index.html](http://www.ibm.com/smarterplanet/us/en/smarter_cities/overview/index.html)

<sup>11</sup> <http://www.forrester.com/pimages/rws/reprints/document/82981/oid/1-LTEQ9N>

<sup>12</sup> Murakami S., Kawakubo S., Asamai Y., Ikaga T., Yamaguchi N., and Kaburagi S. (2011). Development of comprehensive city assessment tool: CASBEE-City, Building Research & Information (2011) 39(3), 195-210.

<sup>13</sup> <http://euronet.uwe.ac.uk/www.sustainable-cities.org/indicators/ECI%20Final%20Report.pdf>



**Table 1 (end)**

Pollution and waste			
Waste	Air	Water	Noise
<ul style="list-style-type: none"> <li>▪ Waste</li> <li>▪ Management</li> <li>▪ Wastewater treatment</li> </ul>	<ul style="list-style-type: none"> <li>▪ Urban particulates and air quality</li> <li>▪ Indoor air pollution</li> <li>▪ Local ozone</li> <li>▪ Regional ozone</li> <li>▪ NO<sub>x</sub> and SO<sub>x</sub></li> </ul>	<ul style="list-style-type: none"> <li>▪ Drinking water</li> <li>▪ Water quality index</li> <li>▪ Water stress</li> <li>▪ Water management</li> </ul>	<ul style="list-style-type: none"> <li>▪ Noise pollution</li> </ul>
Social, economy and health			
<ul style="list-style-type: none"> <li>▪ Social services</li> <li>▪ Citizen satisfaction</li> <li>▪ Education</li> <li>▪ Culture and recreation</li> <li>▪ Social inclusion</li> <li>▪ Demographics (aging)</li> </ul>	<ul style="list-style-type: none"> <li>▪ Gross Domestic Product (GDP)</li> <li>▪ Employment</li> <li>▪ Financial resilience</li> </ul>	<ul style="list-style-type: none"> <li>▪ Adequate sanitation</li> <li>▪ Disease control and mitigation</li> <li>▪ Citizen health services</li> </ul>	

The categories and components reflected in Table 1 evidence that the environment and sustainability dimension is pivotal to the operations of cities. At the same time, these components can be used as the basis to design indicators and methods to assess the city's performance in this field. The development of key performance indicators for SSC is the focus of one of the Technical Reports produced by FG-SSC<sup>14</sup>.

Furthermore, based on Table 1, it is clear that a wide variety of different attributes representing different aspects related to a city contribute to this dimension. These can be summarized as policy, infrastructure, management, climate change and CO<sub>2</sub> emissions, energy, pollution: water, air, waste, noise and their implications on the social, health and economic well-being.

## 2.2 City level services

The second dimension of a city is its services and how they characterize a functional urban environment. Various studies <sup>15 16 17 18 19</sup> suggest the following attributes for this dimension:

<sup>14</sup> <http://www.itu.int/en/ITU-T/focusgroups/ssc/Pages/default.aspx>

<sup>15</sup> [http://www.cityindicators.org/Deliverables/Indicators%20revised%20-core%20and%20supporting\\_8-31-2009-1743191.pdf](http://www.cityindicators.org/Deliverables/Indicators%20revised%20-core%20and%20supporting_8-31-2009-1743191.pdf)

<sup>16</sup> UN (2011), The Global Compact Cities Programme – <http://citiesprogramme.com>

<sup>17</sup> Circles of Sustainability: <http://citiesprogramme.com/wp-content/uploads/2013/04/Urban-Profile-Process-Tool-V3.3-web.pdf>

<sup>18</sup> Siemens websites include links to the Green city index reports.  
<http://www.nwe.siemens.com/sweden/internet/se/Smartcity/Pages/Default.aspx>  
<http://www.siemens.com/entry/cc/en/urbanization.htm?stc=wwccc020805>

<sup>19</sup> [http://www.citigroup.com/citi/citiforcities/home\\_articles/n\\_eiu.htm](http://www.citigroup.com/citi/citiforcities/home_articles/n_eiu.htm);  
[http://www.citigroup.com/citi/citiforcities/pdfs/eiu\\_hotspots\\_2012.pdf](http://www.citigroup.com/citi/citiforcities/pdfs/eiu_hotspots_2012.pdf)

- technology and infrastructure
- sustainability
- governance
- economy

Each of these attributes and their components are described below:

**Table 2 – Categories and components of the city level services dimension**

Technology and infrastructure	Sustainability
<ul style="list-style-type: none"> <li>▪ Transportation</li> <li>▪ Buildings</li> <li>▪ Fire and emergency response</li> <li>▪ Health care</li> <li>▪ Urban planning</li> <li>▪ Safety and security</li> <li>▪ Education</li> </ul>	<ul style="list-style-type: none"> <li>▪ Environmental and natural hazards</li> <li>▪ Water: consumption, leakage</li> <li>▪ CO<sub>2</sub>: emissions, reduction</li> <li>▪ Air Quality: NO, SO, particulates</li> <li>▪ Waste: solid, water, land use</li> <li>▪ Policies: recycling, reduction</li> <li>▪ Energy: consumption, intensity</li> </ul>
Governance	Economy
<ul style="list-style-type: none"> <li>▪ Organization</li> <li>▪ Law and justice</li> <li>▪ Resilience</li> <li>▪ Leadership</li> <li>▪ Commitment</li> <li>▪ Environmental regulation</li> </ul>	<ul style="list-style-type: none"> <li>▪ Economic strength</li> <li>▪ Human capital</li> <li>▪ Institutional effectiveness</li> <li>▪ Financial maturity</li> <li>▪ Physical (financial) capital</li> <li>▪ Production/resourcing</li> </ul>

It can be observed that some of the attributes for this dimension are common to those discussed in the “environment and sustainability dimension”; however, while there are overlapping components, the lens through which they are viewed differ. For one, the environment and sustainability dimension views these shared attributes as the backdrop of a functional smart sustainability city, while the city level service dimension focuses on the operational aspect of these shared attributes and thus form corresponding strategies that would ensure and provide quality services.

## 2.3 Quality of life

Quality of life (QoL) is a recurrent theme in understanding the nature and operation of a city and a key dimension since it reflects how citizens or inhabitants of a city perceive their own sense of well-being. People are constantly striving to better themselves across many facets of their lives. The trend of rapid urbanization is reflected here because of the migration to urban areas in search of better employment and hopefully improved living conditions.

The World Health Organization (WHO) defines quality of life as an individual's perception of their position in life in the context of the culture and value systems in which they live and in relation to their goals, expectations, standards and concerns. It is a broad ranging concept affected in a complex way by the person's physical health, psychological state, personal beliefs, social relationships and their relationship to salient features of their environment.<sup>20</sup>

<sup>20</sup> <http://www.who.int/healthinfo/survey/whoqol-qualityoflife/en/>

The multidimensional nature of the quality of life incorporates (among others) basic needs: water, food, shelter, health, jobs (economy), safety and security, education, culture, environment, social equity, technology and innovation. Another way to look at this dimension is the concept of “well-being” – physical, material, social and emotional.

Despite the complexity of this dimension, the overarching element shared by the different natures of the quality of life is that the QoL for citizens living in an urban environment must be constantly improving in a steady pace as this is the basis for a prosperous city.

Some studies have focused on this aspect<sup>21 22 23 24</sup>, among them the Global City Indicators Facility<sup>25</sup>. Twenty "themes" are organized into two categories: (1) those which measure city services and (2) quality of life factors. City performance is measured by 115 indicators across these themes, collectively used to "tell a story." Approximately 35% of the indicators provide basic statistics and background information for comparative studies, approximately 25% of these are "core" standards, and all cities participating are expected to report on them. The remaining 40% are considered "supporting" indicators where cities in developing economies are encouraged, but not mandated to report the information, since there are differences in resources and capabilities compared to developed economies.

## 2.4 Summary

In summary, three different dimensions have been identified for a city along with key attributes. These dimensions are: (1) environment and sustainability, (2) city level services and (3) quality of life. Each of these dimensions has a number of important attributes and in some cases there is some overlap in what these attributes represent; it is recognized that the "lens" through they are viewed can vary and therefore a 360° view is important to consider.

The following reclassification into four areas (pillars), listed below, for a city is observed – representing the three dimensions and attributes. It should be noted that technology and infrastructure are discussed separately since they tend to have a broader role in a city landscape. Details of these pillars are provided in Table 3.

- (1) **Economy** – The city must be able to thrive – jobs, growth, finance
- (2) **Governance** – The city must be robust in its ability for administrating policies and pulling together the different elements
- (3) **Environment**<sup>26</sup> – The city must be sustainable in its functioning for future generations
- (4) **Society** – The city is for its inhabitants (the citizens)

<sup>21</sup> <http://www.mercer.com/press-releases/quality-of-living-report-2012>

<sup>22</sup> <http://www.mercer.com/surveys/quality-of-living-report#features>

<sup>23</sup> Economist (2005). The Economist Intelligence Unit's quality-of-life index. Economist Online, December 2004. [http://www.economist.com/media/pdf/QUALITY\\_OF\\_LIFE.pdf](http://www.economist.com/media/pdf/QUALITY_OF_LIFE.pdf)

<sup>24</sup> <https://www.ntt-review.jp/archive/ntttechnical.php?contents=ntr200703043.pdf>

<sup>25</sup> Global city indicators web site <http://www.cityindicators.org/themes.aspx>

<sup>26</sup> The term 'environment' in this particular description incorporates sustainability.



**Table 3 – Core pillars of a smart sustainable city**

Economy	Governance	Environment	Society
<ul style="list-style-type: none"> <li>▪ Employment</li> <li>▪ GDP</li> <li>▪ Market – Global/Local</li> <li>▪ Viability</li> <li>▪ Investment</li> <li>▪ PPP</li> <li>▪ Value chain</li> <li>▪ Risk</li> <li>▪ Productivity</li> <li>▪ Innovation</li> <li>▪ Compensation</li> </ul>	<ul style="list-style-type: none"> <li>▪ Regulatory</li> <li>▪ Compliance</li> <li>▪ Processes</li> <li>▪ Structure</li> <li>▪ Authority</li> <li>▪ Transparency</li> <li>▪ Communication</li> <li>▪ Dialogue</li> <li>▪ Policies</li> <li>▪ Standards</li> <li>▪ Citizen services</li> </ul>	<ul style="list-style-type: none"> <li>▪ Sustainable</li> <li>▪ Renewable</li> <li>▪ Land use</li> <li>▪ Biodiversity</li> <li>▪ Water/Air</li> <li>▪ Waste</li> <li>▪ Workplace</li> </ul>	<ul style="list-style-type: none"> <li>▪ People</li> <li>▪ Culture</li> <li>▪ Social networks</li> <li>▪ Tech Savvy</li> <li>▪ Demographics</li> <li>▪ Quality of life</li> <li>▪ User experiences</li> <li>▪ Equal access</li> <li>▪ End consumers</li> <li>▪ Community needs</li> <li>▪ The city as a database</li> </ul>

### 3 ICT, infrastructure and disasters in SSC

The essential duty of a city is to facilitate the health, safety and security of its citizens. Cities may face various problems like increasing population, unprecedented weather manifestations, natural disasters, unemployment, unique geography, poverty, crime, and other social problems that pose a serious threat to the stable functioning of the city.

Governments are using technological innovations to make a paradigm-shift to tackle the above challenges in urban environments. As a result, an increasing amount of data is collected and brought together at various levels to enable police officials to provide better security, doctors and health care professionals to enhance health care treatments, and inform governmental officials to solve social problems more effectively.

'Smart' can be defined as an implicit or explicit ambition of a city to improve its economic, social and environmental standards<sup>27</sup>. The concept of smartness in terms of performance is highly relevant to technologically implementable solutions.

In many cases, if there is some form of ICT, which is present in a city, the city or its activity is considered "smart". ICT devices and services are only an enabler or purveyor which allows the "smartness" to percolate throughout a system. Just by having a personal computer (PC) or smart phone does not define "smartness" or intelligence. Specifically, the International Organization for Standardizations (ISO)<sup>28</sup> has recently released a report (ISO/TR 37150:2014) entitled: "Smart community infrastructures – Review of existing activities relevant to metrics".

<sup>27</sup> [http://www.pleecproject.eu/downloads/Reports/Smart%20City%20Profiles/pleec\\_d2\\_1\\_smart\\_city\\_profiles\\_introduction.pdf](http://www.pleecproject.eu/downloads/Reports/Smart%20City%20Profiles/pleec_d2_1_smart_city_profiles_introduction.pdf)

<sup>28</sup> ISO/TR 37150:2014 "Smart community infrastructures – Review of existing activities relevant to metrics." [http://www.iso.org/iso/executive\\_summary\\_iso\\_37150.pdf](http://www.iso.org/iso/executive_summary_iso_37150.pdf)

Underscoring the need for ICT in ensuring a city is truly sustainable and smart, IBM states that “a smart city is one that makes optimal use of all the interconnected information available today to better understand and control its operations and optimizes the use of limited resources”<sup>29</sup>.

The relevance of urban infrastructure has long been a critical aspect for a smart sustainable city. Traditionally, there have been two types of infrastructure: physical (buildings, roads, transportation, power plants) and digital (IT and communications infrastructure). There is a distinction between these two types of infrastructures – physical and digital, with both operating on separate fields. A convergence of the two, coupled with smart management of the different infrastructures, could provide a multiplier effect.

Disaster management is a critical component to consider when designing a smart sustainable city, as recent experiences from the recent Fukushima, Katrina and 9-11 incidents have evidenced. In the case of the 9-11 tragedy, it has been suggested that the lack of interoperability between the first respondents and other corresponding civic agencies significantly hampered rescue efforts. To this end, the exploration of the use and potential of ICT in the area of disaster management has come to light<sup>30</sup>.

### 3.1 The role of ICT in smart city solutions

The role played by ICTs in SSCs is crucial, due to their ability to act as a digital platform from which an information and knowledge network can be created<sup>31</sup>. Such a network then allows for the aggregation of information and data not only for the purpose of data analysis, but also towards an improved understanding on how the city is functioning in terms of resource consumption, services, and lifestyles. Information made amiable by these digital platforms would serve as a reference for stakeholders to take action and create policy directions that would eventually improve the quality of life for the citizens and the society as a whole.

The multiple systems (infrastructure elements) within a city can be thought of as sub-networks of a larger network, i.e. “system of systems” or a “network of networks”. When these sub-systems are integrated with one another using ICT, they can be thought of as the “Internet of things” (IoT) for cities. All of these systems comprise of sub-systems, components and devices which have nodes, end points and behave like a network in terms of their end use characteristics and interactivity with other nodes. This is completely analogous to an information technology (IT) or data communications network, so mainstream ICT-based management process and approaches can be utilized with some modifications.

#### a. A holistic approach to SSC<sup>32</sup>

In traditional approaches to urban development, all the infrastructure systems are managed in silos, with limited communication and information sharing among and across government departments and civil society. This could be proven detrimental not only for the optimization of resource usage, but also for accessing vital information when needed to inform decisions during emergency situations. Therefore, to become a smart city it is essential to adopt a holistic approach that may

<sup>29</sup> <http://www-03.ibm.com/press/us/en/pressrelease/27791.wss>

<sup>30</sup> <http://www.forbes.com/sites/investor/2011/09/08/911-safety-update-why-first-responder-communications-hasnt-improved-in-10-years/>

<sup>31</sup> <http://itu4u.wordpress.com/2013/09/15/connected-cities-smart-sustainable-cities/>

<sup>32</sup> <http://www.edmonton.ca/transportation/SmarterCitiesChallengeReport.pdf>

involve the creation of multiple infrastructures (as discussed above), as well as strengthening the motivation for government participation, the application of technology, and the integration of various smart infrastructure management systems combined with citizen collaboration.

This integration can be achieved through ICTs, with ICT tools acting as the “glue” between the different physical infrastructures. For example, ICT could be used as the key medium to disseminate information on the locations of electric vehicle charging stations in order to optimize traffic flows and energy usage of electric vehicles.

ICTs also enable the following functions, which are keys to achieving the goals and maximizing the performance of SSCs:

- **ICT-enabled information and knowledge sharing:** Traditionally due to inefficiency on sharing of information, a city may not be ready to solve a problem even if it is well equipped to respond. With immediate and accurate information, cities can gain an insight on the problem and take action before it escalates.
- **ICT-enabled forecasts:** Preparing for stressors like natural disasters requires a considerable amount of data dedicated to study patterns, identify trends, recognize risk areas, and predict potential problems. ICT provides and manages this information more efficiently, so that the city can improve its preparedness and response capability.
- **ICT-enabled integration:** Access to timely and relevant information (e.g. ICT-based early warning systems) need to be ensured in order to better understand the city's vulnerabilities and strengths.

Together with this concept of integration of all the individual services, urban stakeholders can implement, optimize and make the city a smarter and better place to live in.

## b. Data prediction

According to Gartner, **Predictive analytics** describes any approach to data mining with four primary attributes<sup>33</sup>:

- 1) An emphasis on prediction (rather than description, classification or clustering).
- 2) Rapid analysis measured in hours or days (rather than the stereotypical months of traditional data mining).
- 3) An emphasis on the business relevance of the resulting insights.
- 4) An emphasis on ease of use, thus making the tools accessible to business users.

Predictive analysis essentially applies modern statistical techniques of modelling, machine learning, data mining facts (current and historical) to make predictions about future events. Predictive analytics has become an essential tool in business modelling. Such models exploit historical and transactional data to develop a better understanding of behavioural patterns and use them for business purposes, for example, credit scoring techniques.

Such tools can now be applied to large datasets (i.e. Big Data) in order to improve or enhance the city's development. For example, constant data sharing would be able to provide immediate warning for any fragile water pipelines to relevant government departments before it bursts, mobile applications that predict which traffic routes to avoid or use, or predict which trains will be fully occupied at a given time and modelling people flows or workflows with real-time feedback loops.

---

<sup>33</sup> <http://www.gartner.com/it-glossary/predictive-analytics/>



A smart city is therefore a "predictive city"<sup>34</sup> where specific incidents, events or scenarios can be anticipated, the end result being an improved quality of life, or allowing citizens to make more informed and educated decisions on what actions to take next.

### c. Data accessibility and management

Data and information availability are vital for the functioning of any smart solution. Access to data must be possible under any circumstance, thus enabling corresponding actions to be taken by city officials. This is particularly important in the case of emergency and crisis situations.

Cross-scale information sharing using ICTs as platforms allows policy makers and officials from different sectors to base their decisions on common information, and undertake coordinated courses of action. Such data exchange not only strengthens the collaborative efforts between departments and sectors, but could also be used as part of critical assessments and forecasting of various emergencies, as well as to optimize any smart solutions implemented in the city.

Therefore, it is recommended for city managers to base the implementation of smart solutions on appropriate policies and governance structures that can support and sustain such efforts in the short, medium and long term. The following are some of the key components that ensure data accessibility and management in SSC:

- **Accessibility to data:** There is a need for schemas that will promote openness and accessibility to data. While there will always be a concern in terms of “privacy” and the proprietary nature of data, most 'sensitive' data can perhaps be made anonymous before being made accessible. This question of balancing the need for both privacy and accessibility is still not well understood in terms of a legal and regulatory framework and needs to be addressed in the design of smart sustainable cities.
- **Open data:** It is recommended that data on energy, utilities, transportation, and other basic datasets are to be made public. This is vital in facilitating the cross-scale information sharing component of a smart city that was suggested above. Information sharing allows better operational decisions to be made and implemented. It is equally important to note that all data should be presented in a consistent and standardized manner. It is only when all data is based on the same parameters that it allows for meaningful exchanges and decision making, such as in the case of open application programming interfaces (APIs).
- **Managing massive data:** Cities come in various sizes and so does the information associated with them. To get an accurate view of the data from various sources and various places, this information usually comes in huge packets and should be able to provide accuracy, analytical capabilities, data security, and data storage. Therefore, data needs to be managed using highly efficient database constructs.
- **High performance:** Creating new insights from massive volumes of data needs to be complemented with digital infrastructures that are capable of high performance. Large amounts of data can place a lot of pressure on the workload and operational capacity of existing devices. To make the task optimal, the ICT systems should be reliable, ensure precise data transmission, minimize downtime, and avoid system failure. In cases of failure, the solution should be ready to handle and recover from error.

---

<sup>34</sup> Personal Communications, Rob van den Dam, IBM Institute for Business Value, ITU Telecom World 2013.

- **Maximum efficiency:** In order for ICTs to be ready to swiftly disseminate the information from one corner of the city to another, it should operate at its peak efficiency at all points of time. Improving quality and flexibility while minimizing capital and operational cost is crucial for both maximizing and maintaining the role of ICTs over time.

## 3.2 Physical and service infrastructure elements

The following physical and service infrastructures are commonly found in the literature as key aspects for a smart sustainable city:

- Smart energy
- Smart buildings
- Smart transportation
- Smart water
- Smart waste
- Smart physical safety and security
- Smart health care
- Smart education

These infrastructures are traditional and very physical in nature. The convergence with digital (ICT) infrastructures leads them to become “smart”.

### a. Smart energy

Rising energy prices, energy security and theft, depleting energy sources and the global warming caused due to the impact of energy usage are only some of the main issues that drive city managers to look into city sustainability. There is a global water deficit which is a result of the tripling of water demand over the last half-century. Water shortage could quickly translate into food shortages, consequently contributing to the rising food prices. Studies suggest that between early 2007 and 2008, the prices of wheat, rice, corn and soybeans have roughly tripled around the globe. Coupled with the more frequent occurrence of record high temperatures such as in the case of the summer of 2010 in Moscow, energy management needs to be fundamentally restructured<sup>35</sup>. Cities are looking to solve these problems with the development of new technologies to collect information and control energy in order to maximize urban energy consumption levels.

Smart energy management systems use sensors, advanced meters, digital controls and analytic tools to automate, monitor, and control the two-way flow of energy<sup>36</sup>. These systems optimize grid operation and usage by keeping consumers, the producers and providers up to date with the latest technology advancements to deliver energy efficient solutions. This information can help translate real-time data into action.

### b. Smart buildings

Buildings are an urban necessity, and healthy buildings contribute to improve the quality of life by providing comfortable, secure places to live in, work, and play. However, buildings are also the main contributors to greenhouse gas emissions. For example, Canadians spend about 90% of their time

---

<sup>35</sup> "World on the edge, how to prevent environmental and economic collapse", Lester R. Brown.

<sup>36</sup> <http://www.slideshare.net/IMDEAENERGIA/smart-energy-management-algorithms>

indoors, which suggests buildings represent a big part of a city's carbon footprint<sup>37</sup>. In the United States, buildings account for<sup>38</sup>:

- 36% of total energy use and 65% of electricity consumption
- 30% of greenhouse gas emissions
- 30% of raw materials use
- 30% of waste output (136 million tons annually)
- 12% of potable water consumption

Smart building management systems with up-to-date information can make intelligent modifications to improve building energy efficiency, reduce wastage, and make optimum usage of water with operational effectiveness and occupant satisfaction. Moreover, these modifications not only apply to new buildings but also to existing buildings that can take advantage of the new and more energy efficient solutions, and thus reduce their energy use by up to 50% through simple retrofit programmes<sup>39</sup>.

### c. Smart transportation

Transportation solutions are needed in order to move people (and goods) in an efficient (time), safe (secure), cost effective (economic), and an environmentally friendly and sustainable fashion. This typically means that there is a need for some form of "smartness" and occupant satisfaction in order to realize these goals. Therefore, intelligent transport systems (ITS) have become more relevant and are being implemented.

Smart transportation management systems should use technology and collect information about mobility patterns. This information enables city managers to make sure that with the current infrastructure and with lesser investments, the city provides cleaner, efficient and smarter transportation systems. This method lessens the level of wastage and improves the level of citizens' lifestyle, thus overcoming the challenges of transporting goods, services and people from one point to another. In addition, ICT can help to reduce the overall need for transportation and travel by offering virtual alternatives to physical movements.

### d. Smart water

Studies suggest that approximately 783 million people lack access to clean water, 2.5 billion lack access to adequate sanitation, and 6 to 8 million are dying per year due to water-related diseases and disasters. ICTs can play a key role in this respect through a number of technologies that contribute to a better distribution, management, and allocation of water resources.<sup>40</sup>

While the bulk of the Earth's surface is covered with water, less than 3 percent of the water on the earth is fresh water and, of that, less than 1 percent is available for human use. The global groundwater table is dwindling fast and a water crisis is looming. There are increased concerns regarding water availability, quality, lack of infrastructures and the ability to manage water in an efficient and optimal manner. The management of water systems is still nascent, and a growing

<sup>37</sup> <http://vancouver.ca/files/cov/Greenest-city-action-plan.pdf>

<sup>38</sup> <http://www.epa.gov/oaintrnt/projects/>

<sup>39</sup> <http://saveonenergy.ca/Business/Program-Overviews/Retrofit-for-Commercial.aspx>

<sup>40</sup> <http://www.unwater.org/water-cooperation-2013/water-cooperation/facts-and-figures/en/>



science in terms of utilizing, adopting and integrating advanced information technology (IT) remains in the developmental stage.

Water pollution, water wastage, supply and transportation of portable water and the cost associated with the overall water management are some of the issues that challenge the water sector<sup>41</sup>. Lack of awareness of the problem, inadequate information, and difficulties in the ability to demonstrate investment returns are driving governments across the globe to integrate advanced IT techniques and infrastructure to improve the management of water resources<sup>42</sup>.

Smart water management systems use and apply ICT in the development and delivery of solutions to provide access to safe water, manage demand and supply, and develop a pricing mechanism. Examples include:

- Providing continuous monitoring of water quality and availability via smart sensors
- Improving water and energy efficiency
- Enabling better overall water management

This acts as an important factor to connect the problems of consumers with the potential answers of the service providers.

Recognizing that the availability of water has become critical, the Focus Group on Smart Water Management<sup>43</sup> (FG-SWM) was established by the ITU-T TSAG meeting in Geneva, 4-7 June 2013, with ITU-T Study Group 5 as its parent group. The FG-SWM had its first meeting in Lima, Peru, in December 2013.

With urbanization, the problem for sustainable water (environmentally and financially) and sanitation services is becoming a major challenge for cities. ITU aims to acknowledge the water management problems faced by cities and position the implementation of smart water management (SWM), using ICT as an enabler to address, manage and provide potential solutions to alleviate challenges.

The integration of such technologies is adapted to monitor water resources and to understand problems in the urban water sector. All aspects in a city's water system are managed by prioritizing and managing maintenance issues as well as data.

In order to realize these opportunities in cities, the FG-SWM is developing a technical report that emphasizes the need for careful design and proper coordination among all relevant sectors on SWM technologies such as:

- Smart pipes and sensor networks
- Smart metering
- Communication modems
- Geographic information systems (GIS)
- Cloud computing
- Supervisory control and data acquisition (SCADA)
- Models, optimization, and decision-support tools
- Web-based communication and information system tools

---

<sup>41</sup> <http://water.org/water-crisis/water-facts/water/>

<sup>42</sup> <http://www.globalissues.org/article/601/water-and-development>

<sup>43</sup> <http://www.itu.int/en/ITU-T/focusgroups/swm/Pages/default.aspx>

The FG-SWM Technical Report stresses the existence of further opportunities of collaboration in this field, as well as the need to foster further dialogue and discussion on these issues.

#### e. Smart waste

While some cities in the world are converting bird sanctuaries into landfill areas, others are importing waste to meet the ever rising demands of energy from waste. With the ever growing increase in consumer goods, the wastage also has increased exponentially. Cities are finding it difficult to source, segregate different kinds of waste and make use of a product which can be potentially bought back into consumer life cycle.

This challenge can be solved with source reduction, proper identification of the category of waste and development of a proper use for the waste. There may be various forward-looking resolutions for converting waste into a resource and creating closed loop economies, but to enable this process we need proper and correct information and advanced technology.

Smart waste management systems will enable the following areas of action, among others:<sup>44</sup>

- Implementing waste tracking systems to monitor and control the movement of different kinds of waste
- Sorting of waste without the operator coming into contact with it
- Leveraging technology to collect and share data from source to transportation to disposal of waste
- Connecting various smart waste management systems with local waste management service providers

#### f. Smart physical safety and security

Incidents ranging from simple "jumping a traffic signal" to high level security breaches such as in airports can be effectively managed with good information and monitoring systems. These systems provide "on-the-go" data to officials which become an important step in keeping human security-related issues under check. Examples of ICT in physical security<sup>45</sup> include the use of analytical tools which help to sense, respond to and resolve incidents, as well as towards criminal identification, predictive analysis and criminal pattern identification.

As urbanization becomes more mainstream, the following physical safety and security-related trends will become increasingly realized:

- Security will become more critical as cities and their infrastructure evolve
- Cities will continue to grow (i.e. urbanization), resulting in more and more anonymous threats
- There will be increasing pressure on local authorities to cope with expected and unexpected security threats against citizens
- There will be an increased rate of technology adoption and penetration that will enable a more "safe city"
- There will be an increased cooperation between private and public sectors
- Agencies will strengthen their collaboration on city-wide deployments
- There will be a growing integration of existing infrastructures

<sup>44</sup> <http://www.thecitiesoftomorrow.com/solutions/waste/challenges/circular-economies-sustainable-cities>

<sup>45</sup> Smarter Cities Series: Understanding the IBM Approach to Public Safety, REDP-4738.

Overall, it is expected that there will be a growing integration of technologies such as physical security information management (PSIM). Citizen and security agencies will communicate seamlessly through smart technology. Command and control systems will be shared across multiple city departments such as energy, waste, security, and transport, enabling a holistic, city-wide approach. Predictive analytics and data mining will become a mainstay.

Existing security technology such as video surveillance, video analytics, and biometrics will remain the main focus of a city's security and how the analysis of key information flow is the main area for improvement in the next generation of security. According to ITU, the visual surveillance<sup>46</sup> service is “telecommunication service focusing on video (but also including audio) application technology, which is used to remotely capture multimedia (such as audio, video, image and alarm signals) and present them to the end user in a user-friendly manner, based on a managed broadband network with ensured quality, security and reliability.” Requirements for a good visual surveillance system with detailed specifications on functional architecture reference points, signalling and control methods, sets overall protocols for a visual surveillance system.

#### **g. Smart health care**

Smarter health care management converts health-related data into clinical and business insights. Progressive organizations and cities are working together on their health care data to enable secure communications and information sharing. This data empowers health specialists to improve the productivity of the service provided at the point of contact of patients.

Examples of smart health care include the availability of remote alternative diagnoses, remote treatment or tele-assistance, online medical services, requesting an appointment online or the possibility of having a digital record via an electronic health management system, remote home services, alarm systems or even remote patient monitoring systems.

An ITU Focus Group to study Machine-to-Machine (FG-M2M) communications was established under the management of Study Group 11 in February 2012. While M2M is considered a key enabler of applications and services across a broad range of vertical markets (e.g. health care, logistics, transport, utilities, etc.), the Focus Group is first focusing on the health care market and to identify a minimum set of common requirements. Some of the key aspects being studied by the FG-M2M include:

- A "gap analysis" for vertical market M2M service layer needs, initially focusing on applications and services for the health care market
- Identification of a minimum common set of M2M service layer requirements and capabilities, initially focusing on e-health applications and services

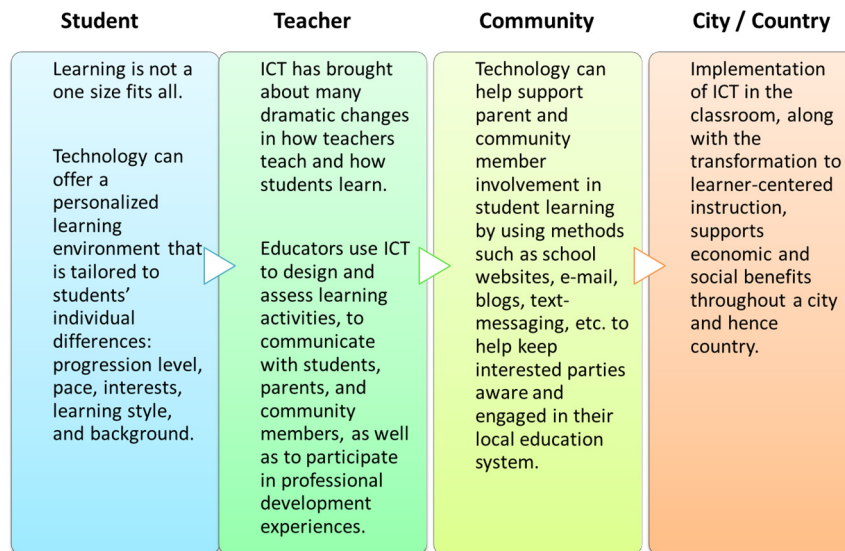
---

<sup>46</sup> <http://www.itu.int/rec/T-REC-H.627-201206-l>



### h. Smart education

Education is a crucial component of smart city services. In the long run, education may be the most important smart city service of all, for adults as well as for children. As the world rapidly globalizes, one of the only ways to stay competitive is to develop and continue to build knowledge-based skills via education. *This includes initial knowledge (e.g. through school, vocational and university education) as well as lifelong learning.* The role of schools and universities is therefore a key element to consider in the design of smart education solutions. While there are many examples of how ICT can positively impact education, the following figure adapted from Intel<sup>47</sup> summarizes some of the key contributions of ICT tools to education.



**Figure 1 – Potential impact of ICT on education<sup>47</sup>**

### Summary of physical and service infrastructures

Table 4 provides some examples of the eight physical infrastructure and service elements of a functioning city seen through a “smart” lens.

<sup>47</sup> <http://www.intel.ie/content/dam/www/public/us/en/documents/flyers/education-ict-benefits-infographic.pdf>

**Table 4 – Examples of city infrastructure applications**

Infrastructure	Example components
<b>Real estate and buildings</b>	<ul style="list-style-type: none"> <li>▪ Synergies between energy efficiency, comfort and safety and security</li> <li>▪ Building as a network: Integration of multiple technologies (HVAC, lighting, plug loads, fire, safety, mobility, renewable, storage, materials, IAQ, etc.)</li> <li>▪ Software: Efficiency, automation and control, analytics and big data management</li> </ul>
<b>Industrial and manufacturing</b>	<ul style="list-style-type: none"> <li>▪ Data interoperability</li> <li>▪ Sustainable production and zero emissions</li> <li>▪ Networked sensors and cloud computing</li> <li>▪ Factories of the future</li> </ul>
<b>Energy and utilities</b>	<ul style="list-style-type: none"> <li>▪ Smart grid and smart metering: Generation/distribution/measurement</li> <li>▪ Wireless communications</li> <li>▪ Analytics and policies</li> <li>▪ Load balancing, decentralization and co-generation</li> </ul>
<b>Air, water and waste management</b>	<ul style="list-style-type: none"> <li>▪ Water information systems (WIS)</li> <li>▪ Integrated water, waste and energy savings optimization schema</li> <li>▪ Sensor networks for water and air systems</li> </ul>
<b>Safety and security</b>	<ul style="list-style-type: none"> <li>▪ Video surveillance and video analytics</li> <li>▪ Seamless communication during natural and man-made disasters</li> </ul>
<b>Health care</b>	<ul style="list-style-type: none"> <li>▪ Smart hospitals</li> <li>▪ Real-time health care including analytics</li> <li>▪ Home and remote health care including monitoring</li> <li>▪ Electronic records management</li> </ul>
<b>Education</b>	<ul style="list-style-type: none"> <li>▪ Flexible learning in an interactive learning environment</li> <li>▪ Accessing world class digital content online using collaborative technologies</li> <li>▪ Massive open online course (MOOC)</li> </ul>
<b>Mobility and transportation</b>	<ul style="list-style-type: none"> <li>▪ Intelligent transportation technologies in the age of smart cities</li> <li>▪ Traffic management: Monitoring and routing</li> <li>▪ Real-time linkage to emissions, traffic patterns, reduced fuel consumption</li> </ul>

### 3.3 ICT infrastructure

There are a number of additional studies<sup>48, 49, 50, 51</sup> that suggest the existence of a series of key dimensions and attributes for cities that are striving for "smartness" and sustainability. Throughout these dimensions, there is a recognition of the essential aspects of an overarching ICT infrastructure that enables all these "smart" attributes to become realized.

<sup>48</sup> Giffinger R. *et al.* (2007). Smart cities, ranking of European medium-sized cities, Final report from Centre of Regional Science, Vienna UT, October 2007.

<sup>49</sup> <http://www.smart-cities.eu/>

<sup>50</sup> Pan J.-G., Lin Y.-F., Chuang S.-Y., Kao Y.-C. (2011). From governance to service-smart city evaluations in Taiwan, Proceedings from the 2011 International Joint Conference on Service Sciences, pp. 334-337.

<sup>51</sup> <http://www.fastcoexist.com/1680538/what-exactly-is-a-smart-city>

ICT infrastructure is a very wide topic by itself. A detailed description of ICT infrastructure is not part of the scope of this Technical Report. At a general level, it is infrastructure that enables computing, communications and associated analysis. ICT infrastructure includes both hardware and software components (e.g. network infrastructure, cloud computing, business and social applications software and access devices).

While the Technical Report<sup>52</sup> produced by ITU-T FG-SSC Working Group 2 focuses on this topic, this section provides a summary of these key components in order to contextualise the notion of SSC and its attributes.

The following topics are highly relevant to the design and functioning of SSCs:

- ICTs specific to smart sustainable cities
- Internet of things
- Ubiquitous sensor networks
- Data security
- Mobile broadband

### ICTs specific to smart sustainable cities

In addition to traditional ICT infrastructures such as network infrastructure, software applications, cloud computing/data platforms and access devices, Table 5 is a sample list (not exhaustive) of communications-related technologies which have relevance to SSCs.

### The Internet of things

An important trend that has gained prominence in the last few years is the 'Internet of things' (IoT). Ashton<sup>53</sup> defined the term in 1998 and re-stated in 2009 that: “Today computers – and, therefore, the Internet – are almost wholly dependent on human beings for information”.

What this actually means is that all objects and equipment in the world will be connected via Internet in one way or another. Internet will be in everything including the jewellery and clothing. Today's information technology is so dependent on data originated by people that our computers know so much about things.

According to recent report by Gartner<sup>54</sup>, the Internet of things (things, people, places and systems) will create new markets and a new economy adding USD 1.9 trillion worth of economic value by 2020. It is further estimated that in the next two years, the combined IT and telecom market will hit almost USD 4 trillion.

Another example of how pervasive the Internet of things could be found from a study by MIT. Researchers from MIT followed close to 3000 items of trash using smart tags and found that the some of this trash travels from its source location in the United States for more than 3 months before they reach a waste disposal unit.<sup>55</sup>

---

<sup>52</sup> <http://www.itu.int/en/ITU-T/focusgroups/ssc/Pages/default.aspx>

<sup>53</sup> <http://www.rfidjournal.com/articles/view?4986>

<sup>54</sup> <http://www.gartner.com/newsroom/id/2621015>

<sup>55</sup> <http://senseable.mit.edu/trashtrack/index.php>



**Table 5 – Smart ICT-based technologies in city infrastructure**

Infrastructure topic	Technologies
<b>Building management</b>	<ul style="list-style-type: none"> <li>▪ Building automation</li> <li>▪ Building control</li> <li>▪ IT network systems</li> <li>▪ Crises management solution (power, infrastructure damage, etc.)</li> </ul>
<b>Data communications and security</b>	<ul style="list-style-type: none"> <li>▪ Voice/video/data</li> <li>▪ Audio visual</li> <li>▪ Structured cabling</li> <li>▪ TCP/IP/BAS protocols</li> <li>▪ Remote VPN Access</li> <li>▪ Computer access</li> <li>▪ Network access</li> <li>▪ Firewalls</li> <li>▪ Managed security services</li> <li>▪ Mobile broadband</li> <li>▪ Mobile security</li> <li>▪ Data security infrastructure</li> </ul>
<b>Smart grid/energy/utilities</b>	<ul style="list-style-type: none"> <li>▪ Energy logistics</li> <li>▪ Distribution (electricity, water, gas)</li> <li>▪ Utility monitor</li> <li>▪ Heat</li> <li>▪ Lighting</li> <li>▪ Back-up power</li> <li>▪ Leakage monitor</li> </ul>
<b>Physical safety and security</b>	<ul style="list-style-type: none"> <li>▪ Access control</li> <li>▪ Video surveillance intrusion detection</li> <li>▪ Biometrics</li> <li>▪ Perimeter and occupancy sensors</li> <li>▪ Fire alarm panels</li> <li>▪ Detection (smoke/heat/gas/flame)</li> <li>▪ Fire suppression</li> <li>▪ Notification and evacuation</li> </ul>
<b>Emergency response</b>	<ul style="list-style-type: none"> <li>▪ Integrated fire department</li> <li>▪ Police and medical services</li> <li>▪ Centralized and remote command and control</li> <li>▪ Scalable decision-making process</li> </ul>
<b>Traffic and transportation (Mobility)</b>	<ul style="list-style-type: none"> <li>▪ Traffic control and monitoring (rail, underground, buses, personal vehicles)</li> <li>▪ 24/7 supply management (logistics)</li> </ul>

A city consists of countless physical structures, layered by multiple infrastructures. It is expected that the information that a city can generate at any moment is massive. As discussed previously, ICT infrastructures are the key layer capable of managing such massive amount of data and of delivering any crucial information to any relevant actors or departments at any given moment. Furthermore, ICT infrastructures, which consist of multiple Internet of things, are not only capable of transmitting data to actors but also to buildings. By allowing communication between buildings, it is expected that efficiency would be maximized particularly in the field of energy consumption and harmful gas emissions.

By 2020, 30 billion things will be interconnected, with each item having a unique Internet protocol (IP) address, thanks to Internet protocol version 6 (IPv6)<sup>56</sup>. Despite of this seemingly large number, it is still very much possible to attach sensors or radio frequency identification device (RFID) tags in every single one of these items, and connecting them through a central platform, thus creating a network similar to the one between Internet and a server. These networks churn out huge volumes of data that is used for analytical modelling. Another revolution is that these physical information systems are now being deployed and function automatically.

Along with technological advancements, the adoption of Internet of things is growing rapidly. The data from sensors is collected, processed and analyzed in real time, and lowering costs is expected to speed their adoption.<sup>57</sup> Corporations should consider the impacts and opportunities arising from the Internet of things. IoT can be viewed as a global infrastructure for the information society, the technology that connects not just humans with things but also things with every other thing. The Internet of things (IoT) is a vision that connects technological and societal implications.

Recommendation ITU-T Y.2060<sup>58</sup> provides an overview of the Internet of things (IoT). This protocol adds more clarity to the concept and scope of IoT, classifies the fundamental characteristics and high-level requirements of IoT and also describes the IoT reference model.

### Mobile broadband

Mobile broadband is a mainstay of information and data communication. The GSMA (GSM Association)<sup>59</sup> states that as of Q1 2013, there are over 1.6 billion mobile broadband users. Mobile broadband now accounts for a quarter of global connections at over 1.6 billion (as of Q1 2013). There are over 350 million users in Europe, almost 800 million users in Asia, 525 million in the Americas and even 60 million in Africa. High speed packet access (HSPA) makes up most of the mobile broadband connectivity and has been the fastest growing wireless technology with a rate of adoption (since its introduction six years ago) ten times faster than the uptake of the global system for mobile communication (GSM) phones when they were introduced in the mid-1990s. With the advent of 4G and long-term evolution (LTE), there is an ever bigger push towards higher speed, secure data connectivity on the go.

Full hypertext mark-up language (HTML) (soon to be HTML5) browsers on smart phones has made ubiquitous access to the web commonplace. Access to e-mail – anywhere, anytime has had a tremendous impact on productivity and is now an integral part of both personal and working lives. The proliferation of applications or "apps" offers convenient access to services through a rich user

---

<sup>56</sup> <https://www.abiresearch.com/research/service/internet-of-everything/>

<sup>57</sup> <https://www.abiresearch.com/research/service/internet-of-everything/>

<sup>58</sup> <http://www.itu.int/rec/T-REC-Y.2060-201206-I>

<sup>59</sup> <https://gsmaintelligence.com/analysis/2013/01/dashboard-mobile-broadband/364/>

experience, often for free or at a low price. Voice and video are already transforming the next generation of mobile broadband with the integration of these technologies into applications such as WhatsApp, Viber, FaceTime and You-Tube all on mobile broadband.

One example of such an application is “Waze”, (recently acquired by Google) using crowd sourcing. Waze uses data gathered from global positioning system (GPS) and location data from smart phones to inform users about traffic patterns including how fast or slow the traffic was moving. It is not difficult to imagine a series of "smart sustainable city applications" such as smart energy, smart pollution, smart water, smart noise – all of which enable the general public not only to be able be better informed, but also to interact in real time with their environment

This unprecedented uptake of smartphones, coupled with the “app revolution” and the robust mobile broadband backbone, have begun to foster widespread innovations that are expected to help make the urban landscape more inclusive, safe and sustainable.

### Ubiquitous sensor networks

A related topic to the IoT is that of ubiquitous sensor networks (USN). USNs utilize wire line and/or wireless sensor networks. These networks consist of interconnected autonomous devices distributed across the location, and use sensors to collectively monitor physical/environmental conditions (e.g. temperature, sound, vibration, pressure, motion or pollutants). USNs are conceptual networks built over existing physical networks; they make use of sensed data and provide knowledge services to anyone, anywhere at any time. Context awareness contributes to the generation of information for decision-making.

Recommendation ITU-T Y.2221<sup>60</sup> has prepared a description on general features of USN and its applications and services publicly available. It also analyses the service necessities of USN applications and services and highlights the new capabilities and requirements based on the services.

### Data security<sup>61</sup>

Population growth, economic crisis, resource crisis, growing energy demands, compliance to the urgency to carbon emission targets, increasing importance to public safety and security and exposure to online data transmission are driving the cities to become smarter.

Cities access a lot of information through the ICT system. More information means more knowledge and more vulnerability to data security. The more complex a system is the higher the need is for cities to protect the data. Some examples of verticals where the data security is important include energy, transportation and health care services:

- Energy data security – Attacks on the energy systems can lead to interruptions and also hinder data exchange between energy distribution centres and end users, and severely compromise the delivery of energy services.
- Transportation data security – A small hindrance caused to the flow of data or the traffic control systems will affect the overall aim of transportation optimization. For example, traffic management could be weakened when the navigation system is hacked leading to confusion and directing to wrong routes.

---

<sup>60</sup> <http://www.itu.int/rec/T-REC-Y.2221-201001-I/en>

<sup>61</sup> Transformational 'smart cities': cyber security and resilience, Executive Report, Giampiero Nanni, Symantec (2013).



- Healthcare data security – ICT in health care is now fast becoming a reality. In this context, backup, cyber security and authentication solutions can ensure that health care systems offer such reliability and integrity, as well as patient privacy.

The following is an example of a step-by-step implementation approach for data security at a city level:

- Establishing the governance framework – Identifying key stakeholders in the government administration level and citizen associations.
- Fulfilling Governance, risk and compliance – Fulfilling the duty of governance with the inputs from different stakeholders at a policy level.
- Service continuity – Cities should create a group of people or organization who can monitor and measure for data security on a continuous basis. A partner with cities for data security.
- Information Protection – The cities needs a safe data storage area. Infrastructure managing services can be practiced by protecting information through efficient tools after partnering with the organizations which provide service continuity.
- User authentication – Before and during data sharing, a strong authentication process of the user should be in place.
- Infrastructure protection – Protection of storage areas and the data management systems are important.
- Response to data security threats – Visibility to possible threats to data security and efficient threat management strategies should be in place.

### 3.4 Emergency/disaster response mechanisms

Disasters are events that exceed the response capabilities of a community and/or the organizations that exist within it. Natural hazards, building environment, political/social unrest, as well as IT and data security are potential risks to consider.

During a disaster or an emergency, a smart city must be able to provide swift responses in a time-sensitive manner, as well as disaster-specific recommendations. No plan can anticipate or include procedures to address all the human, operational and regulatory issues. Essential business transactions must function, addressing needs assessment, communication, volunteer outreach and coordination, grant applications, and community assistance under rapidly changing circumstances<sup>62</sup>.

There is an applied case of the technology to reinforce the disaster prevention that is one of the roles of the ICT in smart sustainable cities<sup>63</sup>. During a disaster or emergency situation, it is sometimes very difficult to get an accurate real-time assessment of the situation on the ground. There is a lot of data, which needs to be obtained, analyzed and shared among many different agencies, organizations and individuals. Technology, especially ICT, has the ability and potential to address and solve some of these issues by providing the appropriate (relevant) information from various sources. ICT can aggregate, create, integrate information, and search the heterogeneous and multi-domain data and deliver a comprehensive set of information, appropriate for each end user. This typically implies "Big Data" type of analysis including real-time sensing data, social sensing

<sup>62</sup> [http://www.cof.org/files/Documents/Community\\_Foundations/DisasterPlan/DisasterPlan.pdf](http://www.cof.org/files/Documents/Community_Foundations/DisasterPlan/DisasterPlan.pdf)

<sup>63</sup> <http://ifa.itu.int/t/fg/ssc/docs/1309-Madrid/in/fg-ssc-0036-nict.doc>

data from social networking services (SNS) (e.g. Twitter), web archives, and scientific databases, which are collected and accumulated via the Internet from various individuals and organizations.

A smart city should have carried out risk assessment with respect to its susceptibility to various natural disasters and should have a strategy in place to deal with natural disasters to which it is highly susceptible.

Cities worldwide are placing increasing importance on building up resilience to natural disasters. These include flooding, extreme weather, as well as heat and water stress, all linked to climate change. Sophisticated ICT infrastructure combined with analytical capabilities aid smart cities confronted by natural disasters to manage the information flow. This may be between multiple public agencies, such as transport authorities, emergency services and energy providers, and citizens. City municipalities may rely on mobile networks to reach the majority of its citizens at short notice.<sup>64</sup>

The Organisation for Economic Co-operation and Development (OECD) published a study in 2010 estimating that major coastal cities including Miami, New Orleans, Tokyo and New York, would rely on flood defences to protect as many as 150 million people by 2070.<sup>65</sup>

A smart city's disaster resilience solutions should cover observation systems, information gathering capabilities, data analysis and decision-making aids. These components matched with an intelligent and interoperable warning system will enable cities to respond effectively to natural disasters. This heavily depends on the municipality's uses of ICT infrastructure, including mobile networks, to efficiently receive, process, analyse and redistribute data, and mobilize various city services.

## 4 Conclusions

---

The end goal for a smart sustainable city is to achieve an economically sustainable urban environment without sacrificing the comfort and convenience/quality of life of citizenry.

A smart sustainable city strives to create a sustainable living environment for all its citizens through the use of information and communication technologies (ICTs). The various attributes of a smart sustainable city need to be identified and can be used as part of the metrics and reference points for defining the smartness and the sustainability of a city. This will help contribute to a better, more in-depth understanding of what constitutes a smart sustainable city.

While the actual development of key performance indicators (KPIs) for a smart sustainable city is outside the scope of this Technical Report, The latter does provide however some background towards the identification and development of such KPIs. A separate detailed report on such KPIs has been prepared by the ITU-T FG-SSC Working Group 3.

What a smart sustainable city is depends on the "lens" or viewpoint from which one looks at a city. There are three key dimensions for a city, each of which has a number of attributes:

- **Environment and sustainability** – Related to city infrastructure and governance, energy and climate change, pollution and waste, and social, Economy and health.
- **City level services** – Viewing through an "urban" lens, there are multiple aspects and indicators including: technology and infrastructure, sustainability, governance and economics.

---

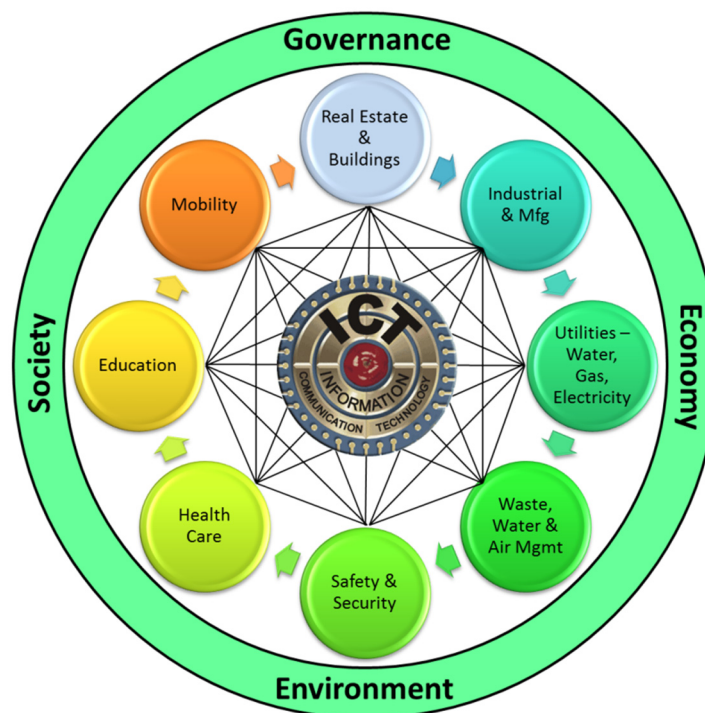
<sup>64</sup> [http://www.gsma.com/connectedliving/wp-content/uploads/2013/02/cl\\_SmartCities\\_emer\\_01\\_131.pdf](http://www.gsma.com/connectedliving/wp-content/uploads/2013/02/cl_SmartCities_emer_01_131.pdf)

<sup>65</sup> [http://www.rms.com/publications/OECD\\_Cities\\_Coastal\\_Flooding.pdf](http://www.rms.com/publications/OECD_Cities_Coastal_Flooding.pdf)

- **Quality of life** – An improvement in the quality of life of a city's inhabitants or populace.

The above dimensions can be reclassified into four overarching pillars incorporating the different attributes (illustrated in the outer ring of Figure 2):

- **Economy** – The city must be able to thrive – e.g. jobs, growth, and finance.
- **Governance** – The city must be robust in its ability to administer policies and pull together the different elements.
- **Environment**<sup>66</sup> – The city must be sustainable in its functioning for future generations.
- **Society** – The city is for its inhabitants (the citizens).



**Figure 2 – Pictorial representation of a smart and sustainable urban landscape**

The above four pillars are enabled through a series of physical and service infrastructures which form a city's lifeline including (but are not limited to):

- Real estate and buildings
- Industry and manufacturing
- Utilities/energy
- Waste, water and air management
- Physical safety and security
- Health care
- Education
- Mobility

<sup>66</sup> The term 'environment' in this particular description incorporates sustainability.

The ICT infrastructure is at the core and acts as the nerve centre, orchestrating all the different interactions between the pillars and the infrastructure elements. It is an essential ingredient, since it acts as the "glue" that integrates all the other elements of the smart sustainable city in the form of a foundational platform. ICT acts as the "great equalizer" (human-to-human, human-to-machine and machine-to-machine) to connect a variety of everyday living services to public infrastructures, such as utilities, mobility and water.



## Glossary

API	Application Programming Interface
BAS	Building Automation System
BREEAM	Building Research Establishment Environmental Assessment Methodology
BRT	Bus Rapid Transit
FG-SCC	ITU-T Focus Group on Smart Sustainable Cities
GDP	Gross Domestic Product
GIS	Geographic Information System
GPS	Global Positioning System
GRP	Gross Regional Product
GSM	Global System for Mobile communication
HSPA	High Speed Packet Access
HTML	HyperText Markup Language
HVAC	Heating, Ventilation, Air Conditioning
IAQ	Indoor Air Quality
ICT	Information and Communication Technology
IoT	Internet of Things
IP	Internet Protocol
IPv6	Internet Protocol version 6
IT	Information Technology
ITS	Intelligent Transport System
KPI	Key Performance Indicator
LEED	Leadership in Energy and Environmental Design
LF	Labour Force
LTE	Long-Term Evolution
M2M	Machine-to-Machine
MOOC	Massive Open Online Course
MWh	Megawatt hour
NO	Nitrogen Oxides
PC	Personal Computer
PPP	Purchasing Power Parity
PSIM	Physical Security Information Management
QoL	Quality of Life
R&D	Research and Development
RFID	Radio Frequency Identification Device
SCADA	Supervisory Control and Data Acquisition
SCC	Smart Sustainable Cities
SDO	Standards Development Organization
SG	Study Group
SNS	Social Network Service
SO	Sulfur Oxides

SWM	Smart Water Management
TCP	Transmission Control Protocol
USN	Ubiquitous Sensor Network
VPN	Virtual Private Network
WG	Working Group
WiFi	Wireless Fidelity
WIS	Water Information System

## Bibliography

1. [http://www.un.org/en/development/desa/policy/wess/wess\\_current/wess2013/WESS2013.pdf](http://www.un.org/en/development/desa/policy/wess/wess_current/wess2013/WESS2013.pdf)
2. [http://www.unhabitat.org/downloads/docs/E\\_Hot\\_Cities.pdf](http://www.unhabitat.org/downloads/docs/E_Hot_Cities.pdf)
3. <http://www.un.org/en/sustainablefuture/cities.shtml>
4. <http://www.itu.int/en/ITU-T/focusgroups/ssc/Pages/default.aspx>
5. [http://www.itu.int/en/ITU-T/focusgroups/ssc/Documents/ToR\\_FG%20SSC.docx](http://www.itu.int/en/ITU-T/focusgroups/ssc/Documents/ToR_FG%20SSC.docx)
6. Esty, D. C., Levy, M. A., Kim, C. H., de Sherbinin A., Srebotnjak T., and Mara, V. (2008), *2008 Environmental Performance Index*, New Haven: Yale Centre for Environmental Law and Policy.
7. <http://ec.europa.eu/environment/europeangreencapital/applying-for-the-award/evaluation-process/index.html#sthash.QXukMUww.dpuf>
8. IBM smart cities website  
[http://www.ibm.com/smarterplanet/us/en/smarter\\_cities/overview/index.html](http://www.ibm.com/smarterplanet/us/en/smarter_cities/overview/index.html)
9. <http://www.forrester.com/pimages/rws/reprints/document/82981/oid/1-LTEQ9N>
10. Murakami, S., Kawakubo, S., Asamai, Y., Ikaga, T., Yamaguchi, N. and Kaburagi, S. (2011), *Development of comprehensive city assessment tool: CASBEE-City*, Building Research & Information (2011) 39(3), pp. 195-210.
11. <http://euronet.uwe.ac.uk/www.sustainable-cities.org/indicators/ECI%20Final%20Report.pdf>
12. <http://www.mercer.com/press-releases/quality-of-living-report-2012>
13. <http://www.mercer.com/surveys/quality-of-living-report#features>
14. Economist (2005). The Economist Intelligence Unit's quality-of-life index. Economist Online, December 2004. [http://www.economist.com/media/pdf/QUALITY\\_OF\\_LIFE.pdf](http://www.economist.com/media/pdf/QUALITY_OF_LIFE.pdf)
15. <https://www.ntt-review.jp/archive/ntttechnical.php?contents=ntr200703043.pdf>
16. Global city indicators web site <http://www.cityindicators.org/>
17. [http://www.cityindicators.org/Deliverables/Indicators%20revised%20-core%20and%20supporting\\_8-31-2009-1743191.pdf](http://www.cityindicators.org/Deliverables/Indicators%20revised%20-core%20and%20supporting_8-31-2009-1743191.pdf)
18. UN (2011), The Global Compact Cities Programme – <http://citiesprogramme.com>
19. Circles of Sustainability: <http://citiesprogramme.com/wp-content/uploads/2013/04/Urban-Profile-Process-Tool-V3.3-web.pdf>
20. Siemens websites include links to the Green city index reports.  
<http://www.nwe.siemens.com/sweden/internet/se/Smartcity/Pages/Default.aspx>  
<http://www.siemens.com/entry/cc/en/urbanization.htm?stc=wwccc020805>
21. [http://www.citigroup.com/citi/citiforcities/home\\_articles/n\\_eiu.htm](http://www.citigroup.com/citi/citiforcities/home_articles/n_eiu.htm);  
[http://www.citigroup.com/citi/citiforcities/pdfs/eiu\\_hotspots\\_2012.pdf](http://www.citigroup.com/citi/citiforcities/pdfs/eiu_hotspots_2012.pdf)
22. ISO Draft Proposal for Smart Community Infrastructures: ISO/DTR/ 37150 – confidential draft provided by ISO (Sept. 2013). Not Published as of 15 December 2013.
23. Giffinger R. *et al.* (2007), *Smart cities, ranking of European medium-sized cities*, Final report from Centre of Regional Science, Vienna UT, October 2007. [http://www.smart-cities.eu/download/smart\\_cities\\_final\\_report.pdf](http://www.smart-cities.eu/download/smart_cities_final_report.pdf)

24. <http://www.smart-cities.eu/>
25. Pan, J.-G., Lin, Y.-F., Chuang, S.-Y., and Kao, Y.-C. (2011), *From governance to service-smart city evaluations in Taiwan*, Proceedings from the 2011 International Joint Conference on Service Sciences, pp. 334-337.
26. <http://www.fastcoexist.com/1680538/what-exactly-is-a-smart-city>
27. <http://www-03.ibm.com/press/us/en/pressrelease/27791.wss>
28. <http://itu4u.wordpress.com/2013/09/15/connected-cities-smart-sustainable-cities/>
29. [http://en.wikipedia.org/wiki/Predictive\\_analytics](http://en.wikipedia.org/wiki/Predictive_analytics)
30. Personal Communications, Rob van den Dam, IBM Institute for Business Value, ITU Telecom World 2013.
31. <http://www.slideshare.net/IMDEAENERGIA/smart-energy-management-algorithms>
32. <http://www.epa.gov/oaintrnt/projects/>
33. [www.imf.org/external/pubs/ft/fandd/2007/09/bloom.htm](http://www.imf.org/external/pubs/ft/fandd/2007/09/bloom.htm), The Urban Revolution – David E. Bloom and Tarun Khanna, Harvard University.
34. <http://water.org/water-crisis/water-facts/water/>
35. <http://www.globalissues.org/article/601/water-and-development>
36. <http://www.itu.int/en/ITU-T/focusgroups/swm/Pages/default.aspx>
37. <http://www.thecitiesoftomorrow.com/solutions/waste/challenges/circular-economies-sustainable-cities>
38. Smarter Cities Series: Understanding the IBM Approach to Public Safety, REDP-4738 [www.redbooks.ibm.com/redpapers/epubs/redp4738.epub](http://www.redbooks.ibm.com/redpapers/epubs/redp4738.epub)
39. <http://www.itu.int/rec/T-REC-H.627-201206-I>
40. <http://www.intel.ie/content/dam/www/public/us/en/documents/flyers/education-ict-benefits-infographic.pdf>
41. <http://www.rfidjournal.com/articles/view?4986>
42. <http://senseable.mit.edu/trashtrack/index.php>
43. <https://www.abiresearch.com/research/service/internet-of-everything/>
44. [http://www.mckinsey.com/insights/high\\_tech\\_telecoms\\_internet/the\\_internet\\_of\\_things](http://www.mckinsey.com/insights/high_tech_telecoms_internet/the_internet_of_things)
45. <http://www.itu.int/rec/T-REC-Y.2060-201206-I>
46. <https://gsmainelligence.com/analysis/2013/01/dashboard-mobile-broadband/364/>
47. <http://www.itu.int/rec/T-REC-Y.2221-201001-I/en>
48. Transformational 'smart cities': cyber security and resilience, Executive Report, Giampiero Nanni, Symantec (2013).
49. [http://www.cof.org/files/Documents/Community\\_Foundations/DisasterPlan/DisasterPlan.pdf](http://www.cof.org/files/Documents/Community_Foundations/DisasterPlan/DisasterPlan.pdf)
50. <http://ifa.itu.int/t/fg/ssc/docs/1309-Madrid/in/fg-ssc-0036-nict.doc>
51. [http://www.gsma.com/connectedliving/wp-content/uploads/2013/02/cl\\_SmartCities\\_emer\\_01\\_131.pdf](http://www.gsma.com/connectedliving/wp-content/uploads/2013/02/cl_SmartCities_emer_01_131.pdf)
52. [http://www.rms.com/publications/OECD\\_Cities\\_Coastal\\_Flooding.pdf](http://www.rms.com/publications/OECD_Cities_Coastal_Flooding.pdf)



53. <http://nsn.com/news-events/publications/unite-magazine-february-2010/the-ict-behind-cities-of-the-future>
54. [http://www.askoxford.com/concise\\_oed/infrastructure](http://www.askoxford.com/concise_oed/infrastructure)
55. Sullivan, Arthur, and Sheffrin, Steven M. (2003), *Economics: Principles in Action*, Upper Saddle River, New Jersey 07458: Pearson Prentice Hall. p. 474.
56. [http://en.wikipedia.org/wiki/Environmental\\_management#cite\\_note-Wostl2006-1](http://en.wikipedia.org/wiki/Environmental_management#cite_note-Wostl2006-1)
57. [http://www.stateofgreen.com/en/Profiles/Ramboll/Solutions/Smart-Energy-Cities-\(2\)](http://www.stateofgreen.com/en/Profiles/Ramboll/Solutions/Smart-Energy-Cities-(2))
58. [http://www.itu.int/dms\\_pub/itu-t/oth/4B/01/T4B010000060001PDFE.pdf](http://www.itu.int/dms_pub/itu-t/oth/4B/01/T4B010000060001PDFE.pdf)
59. [Our Common Future, Report of the World Commission on Environment and Development](#), World Commission on Environment and Development, 1987. Published as Annex to General Assembly document A/42/427, [Development and International Co-operation: Environment](#) August 2, 1987.
60. Smart Cities Study: International study on the situation of ICT, innovation and knowledge in cities. Iñaki Azkuna, Mayor of the City of Bilbao [http://www.cities-localgovernments.org/committees/cdc/Upload/formations/smartcitiesstudy\\_en.pdf](http://www.cities-localgovernments.org/committees/cdc/Upload/formations/smartcitiesstudy_en.pdf)
61. [http://www.who.int/mental\\_health/media/68.pdf](http://www.who.int/mental_health/media/68.pdf)
62. Building Ireland's Smart Economy – Government of Ireland 2008 Report [http://www.taoiseach.gov.ie/eng/Building\\_Ireland's\\_Smart\\_Economy/Building\\_Ireland's\\_Smart\\_Economy\\_-\\_Executive\\_Summary.pdf](http://www.taoiseach.gov.ie/eng/Building_Ireland's_Smart_Economy/Building_Ireland's_Smart_Economy_-_Executive_Summary.pdf)
63. [http://www.dot.ca.gov/hq/tpp/offices/ocp/smf\\_files/SMF\\_handbook\\_062210.pdf](http://www.dot.ca.gov/hq/tpp/offices/ocp/smf_files/SMF_handbook_062210.pdf)
64. [http://www.mckinsey.com/insights/urbanization/urban\\_world](http://www.mckinsey.com/insights/urbanization/urban_world)
65. [http://www.smart2020.org/assets/files/01\\_Smart2020ReportSummary.pdf](http://www.smart2020.org/assets/files/01_Smart2020ReportSummary.pdf)
66. <http://gesi.org/SMARTer2020>
67. [http://www.theclimategroup.org/assets/files/information\\_marketplaces\\_05\\_12\\_11.pdf](http://www.theclimategroup.org/assets/files/information_marketplaces_05_12_11.pdf)
68. <http://www.boydcohen.com/smartcities.html>
69. <http://www.fastcoexist.com/1679127/the-top-10-smart-cities-on-the-planet>
70. <http://www.fastcoexist.com/1680967/the-top-10-smartest-cities-in-north-america>
71. [http://www.ubmfuturecities.com/document.asp?doc\\_id=%20524106&page\\_number=2](http://www.ubmfuturecities.com/document.asp?doc_id=%20524106&page_number=2)
72. <http://www.idc-ei.com/getdoc.jsp?containerId=EIRS56T>
73. [http://www.lacatedralonline.es/innova/system/Document/attachments/12501/original/Smart\\_Cities.pdf](http://www.lacatedralonline.es/innova/system/Document/attachments/12501/original/Smart_Cities.pdf)
74. Gartner Group Report Innovation Insight: Smart City Aligns Technology Innovation and Citizen Inclusion G00235001, Dec 2012. <https://www.gartner.com/doc/2286119/innovation-insight-smart-city-aligns>
75. Giffinger, R., Haindlmaier, G., and Kramer, H. (2010), *The role of rankings in growing city competition*, Urban Research & Practice. Vol. 3, No. 3, November 2010, pp. 299-312.
76. Giffinger, R, and Haindlmaier, G. (2010), *Smart cities ranking: an effective instrument for the positioning of cities?* ACE: Architecture, City and Environment, January 2010, ISSN 1886-4805.

## Annex 1

### Smart city dimensions and attributes<sup>67</sup>

Dimension	Attribute	Descriptor	Description
<b>Environment</b>	Smart buildings	Sustainability-certified buildings	Number of LEED or BREEAM sustainability certified buildings in the city
	Resource management	Total energy consumption	Annual total electrical energy consumption per capita (in MWh) Annual electricity consumption per capita (MWh)
		Carbon footprint	Annual CO <sub>2</sub> emissions per capita (in tonnes)
		Waste generation	Annual total waste volume generated by the city per capita (kg) Annual household waste per capita (in kg)
	Sustainable urban planning	Green space per capita	Urban green open areas per capita (in m <sup>2</sup> )
<b>Mobility</b>	Efficient transport	Clean-energy transport	Percentage of clean-energy transport use (electric train, subway/metro, tram, cable railway, electric taxis, bicycles)
	Multi-modal access	Public transport use	Percentage of public transit trips/Total trips
	Technological infrastructure	Access to real-time information	Number of public transit services that offer real-time information to the public: 1 point for each transit category up to 5 total points (bus, regional train, metro, rapid transit system (e.g. bus rapid transit system, BRT, tram), and sharing modes (e.g. bike sharing, car sharing)
<b>Government</b>	Online services	Online procedures	Number of online procedures performed/total procedures
	Infrastructure	Wi-Fi coverage	Number of Wi-Fi – 33 hotspots per km <sup>2</sup>

<sup>67</sup> <http://www.boydcohen.com/smartcities.html>

Dimension	Attribute	Descriptor	Description
		Diversity of sensors	Diversity of installed sensors to monitor the following categories (1 to 5 points): air and noise contamination; waste, transit, emergency, other
		Municipal human resources	Percentage of administrative employees with university degree
	Open government	Datasets	Total number of open datasets (excluding regulations/laws) with information for the last three years
		Open data	Number of publicly available applications utilizing open data
<b>Economy</b>	Opportunity	New start-ups	Number of new opportunity-based start-ups
		R + D	Percentage of GDP invested in R&D in private sector
	Productivity	GRP per capita	Gross regional product (GRP) per capita (in USD)
	Local and global connection	ICT cluster	Percentage of ICT companies based in local clusters
		International-held events	Number of international congresses and fair attendees
<b>Society</b>	Integration	Internet-connected households	Percentage of Internet-connected households
		Gini index	Gini coefficient of inequality
	Education	University graduates	Number of university Graduates per 1000 inhabitants
	Creativity	Creative industry jobs	Percentage of labour force (LF) engaged in creative industries
<b>Quality of life</b>	Culture and well-being	Life conditions	Percentage of inhabitants with housing deficiency in any of the following five areas (potable water, sanitation, overcrowding, deficient material quality, or lacking electricity)
		Investment in culture	Percentage of municipal budget allocated for culture
	Safety	Crime	Number of crimes per 100,000 inhabitants
	Health	Life expectancy	Life expectancy at birth







# 2.2

## Smart Sustainable Cities: an analysis of definitions

## Acknowledgements

This Technical Report was researched and principally authored by Professor Sekhar N. Kondepudi from the National University of Singapore (NUS). Vinod Ramanarayanan, Alok Jain, Guru Nandan Singh, Nitin Agarwal NK, Rahul Kumar and Rahul Singh (NUS), Pernilla Bergmark (Ericsson), Takafumi Hashitani (Fujitsu), Paolo Gemma (Huawei), Ziqin Sang (Fiberhome), Daniela Torres (Telefónica), Angelica Ospina (University of Manchester) and Mythili Menon (University of Geneva) provided inputs to this Technical Report.

The author also acknowledges the guidance and support from all the members of the ITU-T FG-SSC Management Team.

Additional information and materials relating to this Technical Report can be found at: [www.itu.int/itu-t/climatechange](http://www.itu.int/itu-t/climatechange). If you would like to provide any additional information, please contact Cristina Bueti (ITU) at [tsbsg5@itu.int](mailto:tsbsg5@itu.int).

## Table of Contents

		Page
<b>1</b>	<b>Introduction .....</b>	<b>53</b>
1.1	Scope .....	53
<b>2</b>	<b>Goals and motivation for a comprehensive definition .....</b>	<b>54</b>
2.1	Goals .....	54
2.2	Lack of standardized terminologies .....	54
2.3	Need for a comprehensive definition.....	55
<b>3</b>	<b>Observations from literature .....</b>	<b>55</b>
3.1	Attributes.....	55
3.2	Core themes .....	55
3.3	Infrastructure – Physical, service and digital.....	56
<b>4</b>	<b>Definitions and analysis.....</b>	<b>56</b>
4.1	Sources of information .....	56
4.2	Methodology .....	56
4.3	Approach .....	57
<b>5</b>	<b>Results.....</b>	<b>58</b>
5.1	Keyword analysis from definitions .....	58
5.2	Keyword grouping .....	60
5.3	Important terms to be included in a standardized definition.....	62
<b>6</b>	<b>Recommended definition .....</b>	<b>63</b>
6.1	Criteria for definition.....	63
6.2	Specification .....	64
6.3	Agreed definition by FG-SSC.....	64
<b>7</b>	<b>Conclusions .....</b>	<b>65</b>
	<b>Annex 1 – Definitions of a smart sustainable city .....</b>	<b>66</b>
	<b>Annex 2 – References for definitions.....</b>	<b>113</b>
	<b>Annex 3 – Glossary of terms.....</b>	<b>122</b>





## Smart sustainable cities: An analysis of definitions

### Executive summary

This Technical Report was written with the aim of establishing a concrete definition for smart sustainable cities (SSC) which can be used worldwide. Although there is abundant literature available on smart cities, there is no standardized, commonly accepted set of terminologies which would help to aptly describe a "smart sustainable city". Such a standardized definition will help create a more defined structure in relation to information and communication technology (ICT) infrastructure, key performance indicators (KPIs), metrics and policies for smart sustainable cities as viewed by ITU.

The following common criteria was used as a guideline, based on key attributes: (1) sustainability, (2) quality of life, (3) urban aspects, and (4) intelligence or smartness.

Core themes for SSC include: (1) society, (2) economy, (3) environment, and (4) governance.

Approximately 116 existing definitions of smart sustainable cities were studied and analysed by using as a guideline the attributes and themes of SSC developed in a parallel ITU-T Technical Report on the Overview of smart sustainable cities. These definitions were obtained from a variety of sources including: academia and research communities, government initiatives, international organizations (United Nations, ITU, etc.), corporate/company profiles, user centric definitions, trade associations and standards development organizations (SDOs).

Key categories and indicators were established and a list of 30 key terms which should be included in a standardized definition were also identified. The following eight (8) categories were identified to be key for SSC: (1) quality of life and lifestyle, (2) infrastructure and services, (3) ICT, communications, intelligence and information, (4) people, citizen and society, (5) environment and sustainability, (6) governance, management and administration, (7) economy and Finance, and (8) mobility. Six (6) primary indicators were identified to be smart living, smart people, smart environment and sustainability, smart governance, smart mobility and smart economy. The following 30 key words were identified to be representative of SSC.

- ICT
- Adaptable
- Reliable
- Scalable
- Accessible
- Security
- Safe
- Resilient
- Economic
- Growth
- Standard of living
- Employment
- Citizens
- Well-being
- Medical Welfare
- Physical safety
- Education
- Environmental
- Physical and service infrastructure
- Transportation and mobility
- Water
- Utilities and energy
- Telecommunications
- Manufacturing
- Natural and man-made disasters
- Regulatory and compliance
- Governance
- Policies and processes
- Standardization

Finally, based on the above analysis, a proposed definition for a smart sustainable city was approved by ITU-T Study Group 5 “Environment and Climate Change” and UNECE based on the work of the ITU-T FG-SSC reads as follows:

*"A smart sustainable city is an innovative city that uses information and communication technologies (ICTs) and other means to improve quality of life, efficiency of urban operation and services, and competitiveness, while ensuring that it meets the needs of present and future generations with respect to economic, social, environmental as well as cultural aspects".*

# 1 Introduction

---

In 2007, the number of people living in cities surpassed the number of those living in rural areas. It is estimated that the proportion of people living in an urban environment will exceed 70% by 2050. From 1950-2010, small cities have witnessed a net increase of 1.3 billion people, double the number of people inhabiting medium cities (632 million) or large cities (570 million).

People move to urban areas with the hope of finding better job opportunities as well as a better standard of living. However, the increasing number of people migrating to urban areas leads to complex issues such as congestion, increased demand for a limited pool of natural as well as other resources including energy, water, sanitation, education and healthcare services<sup>1</sup>, among others.

Information and communication technologies (ICTs) are able to provide more environmentally friendly and more economically viable solutions to some of the aforementioned problems faced in cities. As of today, ICTs' role in tackling environmental issues has not been completely identified. Potential areas where ICTs can assist include management of water sources, energy efficiency, and solid waste management, public transport infrastructure reducing traffic congestion, growth of ICT infrastructure and managing its environmental impact with reference to concerns related to electromagnetic field (EMF), visual aspects and air quality monitoring<sup>2</sup>.

The main question the Technical Reports series on smart sustainable cities aims to address is: In light of the growing economic and environmental problems in urban areas (as a result of increased rural to urban migration), how can ICTs be used to remedy the situation?

This Technical Report analyses the major aspects of smart cities and eco-cities from: (i) the perspective of academics, (ii) the business initiative approach, and (iii) the international organization collaborations with the final aim of establishing a concrete definition for smart sustainable cities which can be used worldwide. This would also provide a basis for understanding the most common features of smart sustainable cities.

## 1.1 Scope

A Focus Group on Smart Sustainable Cities<sup>3</sup> (FG-SSC) was established in February 2013 by ITU-T Study Group 5 (SG5) which has been working on environmental and climate change issues including the development of a methodology to assess the environmental impact related to ICT in cities.

FG-SSC has been assigned the task to analyse ICT solutions and projects that promote environmental sustainability in cities. This would help identify the best practices using ICTs in cities which can be standardized by ITU-T SG5. FG-SSC has held a series of open meetings with the participation of a variety of stakeholders including ITU-T members, telecommunications companies, ICT companies, governments, academia and others. These open meetings provide a broad-based source of information gathered from all stakeholders. The FG-SSC will leverage the role of the ICT sector to foster the growth of smart sustainable cities worldwide, while developing a standardization roadmap that ensures activities currently undertaken by various standards development organizations (SDOs) and forums are taken into consideration.

---

<sup>1</sup> <http://www.itu.int/en/ITU-T/focusgroups/ssc/Pages/default.aspx>

<sup>2</sup> Organization for Economic Cooperation and Development (OECD): Addressing Environmental Challenges: The role of Information and Communication Technologies (ICTs) and the Internet. 2012

<sup>3</sup> <http://www.itu.int/en/ITU-T/focusgroups/ssc/Pages/default.aspx>

FG-SSC has four (4) main working groups (WGs):

- WG1 – ICT role and roadmap for smart sustainable cities.
- WG2 – ICT infrastructure.
- WG3 – Standardization gaps, KPIs and metrics.
- WG4 – Policy and positioning (communications, liaisons and members).

One of the key deliverables for WG1 in the Focus Group on SSC is to develop a standardized definition for smart sustainable cities: "What definitions and attributes describe a smart sustainable city" especially in terms of ICT infrastructure. In order to help address the above questions, FG-SSC has developed this detailed Technical Report on Smart sustainable cities – an Analysis of Definitions. Using this Technical Report as a basis, the Focus Group will be able to fulfil its mandate to develop a set of Draft Technical Specifications for ITU-T Study Group 5 for a standardized definition of a "smart sustainable city".

## **2 Goals and motivation for a comprehensive definition**

---

### **2.1 Goals**

With rapid urbanization and the obvious need to develop a sustainable model to support anticipated growth, a number of cities in the world has jumped on the 'Smart Sustainable City' bandwagon labelling itself as 'smart' in one way or the other.

The primary goal of this Technical Report is to help understand the multiple definitions of 'Smart Sustainable Cities', based on open literature, perform analysis and then propose a formal and comprehensive definition for the ITU term Smart Sustainable City (which specifically highlights the sustainability aspect in such cities). Such a standardized set of terminologies for a "smart sustainable city" will be useful not only for the definition of the term but also in relation to ICT infrastructure, KPIs, metrics and policies for smart sustainable cities as viewed by ITU.

### **2.2 Lack of standardized terminologies**

Though there is abundant literature available on smart cities, there is no standardized, commonly accepted set of terminologies which would help to aptly describe a "Smart Sustainable City". Depending upon the lens with which it is viewed, there are different descriptors, definitions, attributes, indicators and indices.

To ensure that the sustainability aspect in smart cities is not overlooked, ITU-T Focus Group on Smart Sustainable Cities has conceptualized a new term. Smart sustainable cities which may be considered a variant of smart cities (inclusive of some of the basic features of eco-cities/sustainable cities).

Various definitions and features of smart cities and sustainable cities have to be analysed before setting a standardized definition which is expected to provide a good basis for the development of the concept of smart sustainable cities (SSC) for the Focus Group on SSC and its various stakeholders.

What could be the main features which make a city a "smart sustainable city"? Is it governance, technology, communication, transport, infrastructure, people, economy, environment, natural resources, innovation, quality of living or something more? What are the necessary factors for a city to be called as smart and sustainable?



## 2.3 Need for a comprehensive definition

As discussed in the previous subsection, there is a clear need for a standardized definition for a "smart sustainable city". The process for developing a new definition will clearly pave the way for a more defined structure not only for the definition of the term but also in relation to ICT infrastructure, KPIs, metrics and policies for smart sustainable cities as viewed by ITU. Another aspect which is also critical is that within ITU-T, there are multiple study groups involved with topics which overlap or intersect with smart sustainable cities. Data security (SG17) as well as other SDOs such as ISO, BSI, ANSI, IEC, and IEEE are working on smart sustainable cities as well, albeit through a different lens and based on a different framework.

## 3 Observations from literature

---

The following preliminary observations are made from the literature describing smart and sustainable cities. The definition of a smart sustainable city depends on the lens or the viewpoint taken (refer to Annex 1 for list of definitions and features analysed). This is important to note, since this approach will provide an insight into why and what certain attributes are important. There are many subjective viewpoints of what a smart sustainable city is and these can be segmented into the following categories:

- Attributes
- Themes
- Infrastructure

A combination of smartness/intelligence in an urban environment with sustainability as a key backdrop is the basis for this Technical Report. Note that this Technical Report is not a recommendation document for best practices but a description of what is prevalent in the open literature.

### 3.1 Attributes

The following attributes appear consistently across the literature in terms of describing a smart sustainable city:

- **Sustainability** – This is related to city infrastructure and governance, energy and climate change, pollution and waste, and social, economics and health.
- **Quality of life** – Quality of life (QoL) is a recurrent theme. One of the aims of SSC would be to improve QoL in terms of emotional as well as financial well-being.
- **Urban aspects** – This includes multiple aspects and indicators including: technology and infrastructure, sustainability, governance and economics.
- **Intelligence or smartness** – A "smart" city exhibits implicit or explicit ambition to improve economic, social and environmental standards. Commonly quoted aspects of smartness include smart economy, smart people, smart governance, smart mobility, smart living and smart environment.

### 3.2 Core themes

There are four core themes for a smart sustainable city:

- **Society** – The city is for its inhabitants (i.e. the citizens).
- **Economy** – The city must be able to thrive – jobs, economic growth and finance, etc.

- **Environment** – The city must be sustainable in its functioning for the present as well as future generations.
- **Governance** – The city must be robust in its ability for administrating policies and pulling together the different elements.

### 3.3 Infrastructure – physical, service and digital

Infrastructure in an urban environment can be best described in a threefold manner: physical, service and ICT or digital. Physical infrastructure is what is truly "physical" – for example, buildings, train tracks, roads, electric lines, gas pipelines, water, factories and the like. Service infrastructure is the service overlay on the physical aspects – for example, a transportation service such as Mass Rapid Transit ((MRT), bus), utilities (water, gas, and electricity), education and health care. The ICT infrastructure is essential for a successful smart sustainable city – it acts as the "glue" which integrates all the other elements of the smart sustainable city acting as a foundational platform. ICT infrastructure is at the core and acts as the nerve centre, orchestrating all the different interactions between the various core elements and the physical infrastructure.

## 4 Definitions and analysis

---

### 4.1 Sources of information

This section presents a study of definitions and associated attributes in terms of indicators, indices and rankings of smart sustainable cities. For the purpose of this Technical Report, various articles were collected from the Internet as well as from other databases. These articles were reviewed and analysed to help consolidate a wide range of perspectives which ensures that the definition of smart sustainable cities proposed by the Focus Group includes all major aspects. These definitions were obtained from a variety of sources including:

- Academia and research communities.
- Government initiatives including EU.
- International organizations (United Nations, ITU, etc.).
- Corporate/company profiles.
- User centric definitions (from leading market research firms).
- Trade associations.
- Standards development organizations.

A complete list of over all the definitions found in the open literature is stated in Annex 1.

### 4.2 Methodology

Given the large amount of data, the various indicators, metrics and the 100+ definitions for a smart city, there was a need to perform some in-depth analysis to determine what would be a comprehensive and inclusive definition of a smart sustainable city from the perspective of the work being undertaken by the Focus Group on Smart Sustainable Cities (FG-SSC). All the definitions in Annex 1 were analysed to identify what makes a smart sustainable city. The results from this analysis which identified the top keywords and characteristics of a smart sustainable city are discussed in more detail in section 5.

For each definition, a set of key words was extracted and tabulated. These keywords were then grouped under some common themes. Some words such as "smart" and "city" are implicit and were mentioned in almost every description, so they are not captured explicitly as a separate keyword.

### 4.3 Approach

A systematic approach was followed throughout the study including:

- Top down approach – indicators, indices, and rankings.
- Bottom up approach – definitions, attributes, and descriptors.

As part of the research, multiple words and combinations thereof were used during the search from primary sources. Primary search words included (but not limited to): smart, sustainable, environment, city/cities, definition, attributes, index, indicator, characteristics, ICT, intelligent, urban, methodology, solution, example, success, and ranking. A detailed analysis of different key words and attributes and perspectives from these diverse sources was performed. Such an approach has provided a truly diverse set of definitions and supplied a sense of "completeness" or comprehensiveness to the study.

Based on the definitions, a series of keywords was identified and documented as illustrated in the sample below in Table 1:

**Table 1 – Sample table depicting the definitions, keywords and the respective sources for each**

Source	Definitions	Keywords
Giffinger, Rudolf, <i>et al.</i> . "Smart Cities Ranking of European Medium-sized Cities." Centre of Regional Science, Vienna UT, Oct. 2007. Page 10. Web. Last Accessed 8 Feb. 2014. <a href="http://www.smart-cities.eu/download/smart_cities_final_report.pdf">http://www.smart-cities.eu/download/smart_cities_final_report.pdf</a>	"A city well performing in a forward-looking way in [economy, people, governance, mobility, environment, and living] built on the smart combination of endowments and activities of self-decisive, independent and aware citizens."	Economy, people, governance, mobility, environment, quality of living, forward looking, aware citizens, self-decisive citizens, independent citizens.
Cohen, Boyd. "The Top 10 Smart Cities On The Planet." Fast Company, 11 Jan. 2011. Web. Last accessed 12 Feb. 2014. <a href="http://www.fastcoexist.com/1679127/the-top-10-smart-cities-on-the-planet">http://www.fastcoexist.com/1679127/the-top-10-smart-cities-on-the-planet</a> .	Smart sustainable cities use information and communication technologies (ICT) to be more intelligent and efficient in the use of resources, resulting in cost and energy savings, improved service delivery and quality of life, and reduced environmental footprint – all supporting innovation and the low-carbon economy.	ICT, cost efficiency, energy efficiency, energy savings, quality of life, environment, improved service delivery, innovation, low carbon economy.

Source	Definitions	Keywords
Hitachi. "Smart Sustainable City Overview." <i>Smart Cities: Hitachi</i> . Hitachi, Web. Last accessed 9 Feb. 2014. <a href="http://www.hitachi.com/products/smartcity/vision/concept/overview.html">http://www.hitachi.com/products/smartcity/vision/concept/overview.html</a> .	Hitachi's vision for the smart sustainable city seeks to achieve concern for the global environment and lifestyle safety and convenience through the coordination of infrastructure. Smart Sustainable Cities realized through the coordination of infrastructures consist of two infrastructure layers that support consumers' lifestyles together with the urban management infrastructure that links these together using information technology (IT).	Coordinated infrastructure, lifestyle safety, lifestyle convenience, urban infrastructure, IT.
Meijer, Albert, and Manuel Pedro Rodríguez Bolívar. "Governing the Smart Sustainable City: Scaling-Up the Search for Socio-Techno Synergy." T EGPA 2013 (Edinburgh, September) Permanent Study Group on E-Government, 2013, Web. Last accessed 8 Feb. 2014. <a href="https://www.scss.tcd.ie/disciplines/information_systems/egpa/docs/2013/BolivarMeijer.pdf">https://www.scss.tcd.ie/disciplines/information_systems/egpa/docs/2013/BolivarMeijer.pdf</a>	"We believe a city to be smart when investments in human and social capital and traditional (transport) and modern (ICT) communication infrastructure fuel sustainable economic growth and a high quality of life, with a wise management of natural resources, through participatory governance."	ICT, high quality of life, natural resource management, participatory governance, transport infrastructure, communication infrastructure, economic growth, sustainability.
IBM. "India Needs Sustainable Cities." IBM SMARTER PLANET, Web. Last accessed 6 Feb. 2014. <a href="http://www.ibm.com/smarterplanet/in/en/sustainable_cities/ideas/">http://www.ibm.com/smarterplanet/in/en/sustainable_cities/ideas/</a> .	Replacing the actual city infrastructures is often unrealistic in terms of cost and time. However, with recent advances in technology, we can infuse our existing infrastructures with new intelligence. By this, we mean digitizing and connecting our systems, so they can sense, analyse and integrate data, and respond intelligently to the needs of their jurisdictions. In short, we can revitalize them so they can become smarter and more efficient. In the process, cities can grow and sustain quality of life for their inhabitants.	Technology, connecting systems, analyse data, integrate data, responsive, efficient, growth, quality of life, sustainability.

## 5 Results

### 5.1 Keyword analysis from definitions

All the definitions (listed on Annex 1) were analysed to identify the top keywords and characteristics that make a smart sustainable city. Some words such as "smart" and "city" are implicit and mentioned in almost every description, and hence these words have not been captured explicitly as a separate keyword.

A total of 50 keywords were identified which appeared to have multiple references across all the studied definitions. There were a total number of 726 instances of these 50 keywords. These are captured and presented below in a table to reflect the relative contribution/number of times that these keywords were repeated across all the 100+ definitions. Based on the literature review, a graphical representation of the relative importance of the different keywords was developed. The larger the font is, the more important the word is.



Figure 1 – Word graph depicting the relative importance of the identified keywords

Table 2 reflects a quantitative analysis of different keywords and the number of occurrences that these keywords had from the documents studied (as detailed in Annex 1).

Table 2 – List of keywords, occurrences and relative percentage

No	Keyword	Total Occurrences	% Occurrence
1	Quality of life	44	6.1%
2	Development	16	2.2%
3	Services	10	1.4%
4	Buildings	17	2.3%
5	Health, safety and security	26	3.6%
6	Utilities	3	0.4%
7	Education	16	2.2%
8	Energy	17	2.3%
9	Water	16	2.2%
10	Electricity	3	0.4%
11	Modern	2	0.3%
12	ICT	27	3.7%
13	Technology	42	5.8%
14	Interconnected	1	0.1%
15	Information	24	3.3%
16	Communication	15	2.1%
17	Intelligent	16	2.2%
18	Integrate	22	3.0%
19	Systems	34	4.7%
20	Advanced	1	0.1%
21	Design	4	0.6%
22	Community	5	0.7%
23	Accessible	2	0.3%
24	People	36	5.0%



No	Keyword	Total Occurrences	% Occurrence
25	Urban	16	2.2%
26	Society	6	0.8%
27	Actively	4	0.6%
28	Innovation	15	2.1%
29	Aware	2	0.3%
30	Participatory	3	0.4%
31	Efficient	24	3.3%
32	Sustainable	28	3.9%
33	Adaptable	3	0.4%
34	Optimal	2	0.3%
35	Environment	22	3.0%
36	Resources	27	3.7%
37	Natural	11	1.5%
38	Governance and administration	35	4.8%
39	Management	20	2.8%
40	Capital	4	0.6%
41	Operational	1	0.1%
42	Public	6	0.8%
43	Solutions	4	0.6%
44	Vision	1	0.1%
45	Economy	34	4.7%
46	Investments	9	1.2%
47	Business	13	1.8%
48	Competitive	5	0.7%
49	Mobility	14	1.9%
50	Transport	18	2.5%
<b>Total</b>		<b>726</b>	<b>100%</b>

## 5.2 Keyword grouping

Some logical groupings were made as illustrated by Table 3 and the different keywords mapped into these groupings (appropriately colour coded) in order to better understand the relative importance of the different keywords and categories.

**Table 3 – Logical groupings**

Category	% Occurrence
Quality of life and lifestyle	6%
Infrastructure and services	17%
ICT, communication, intelligence, information	26%
People, citizens, society	12%
Environment and sustainability	17%
Governance, management and administration	10%
Economy and finance	8%
Mobility	4%
<b>Total</b>	<b>100%</b>

In order to minimize any subjectivity in defining the above keyword grouping, a literature search was conducted to best describe each of them. This is important to maintain a baseline of what is meant by each of those keywords.

### ICT/communication/intelligence/information

Information and communication technology (ICT) provides services such as security, health care, and transport for citizens, improved and cost effective power supply for industries, remote working and e-commerce for businesses, as well as entertainment and communications for individuals.<sup>4</sup>

### Infrastructure

Infrastructure includes the basic physical and organizational structures necessary for the operations of society/enterprises and the services/facilities that keep the economy functional.<sup>5, 6</sup>

### Environment/sustainability

As defined by the IUCN, UNEP and WWF: "sustainability is improving the quality of human life while living within the carrying capacity of supporting eco-systems"<sup>7</sup>. The World Commission on Environment and Development<sup>8</sup> (also known as the Brundtland Commission) defines sustainable development as a form of development which "meets the needs of the present without compromising the ability of future generations to meet their own needs".<sup>9</sup>

<sup>4</sup> ICT behind cities of the future. Nokia. Retrieved 29th June 2014 from <http://nsn.com/news-events/publications/unite-magazine-february-2010/the-ict-behind-cities-of-the-future>

<sup>5</sup> Oxford Dictionaries. Retrieved 1st June 2014 from [http://www.askoxford.com/concise\\_oed/infrastructure](http://www.askoxford.com/concise_oed/infrastructure)

<sup>6</sup> Sullivan, Arthur, Steven M. Sheffrin (2003), Economics: Principles in action. Upper Saddle River, New Jersey 07458: Pearson Prentice Hall. p. 474.

<sup>7</sup> IUCN/UNEP/WWF. Caring for the Earth: A Strategy for Sustainable Living. (Gland, Switzerland: 1991). (IUCN – The International Union for Conservation of Nature, UNEP – United Nations Environment Programme, WWF – World Wide Fund for Nature).

<sup>8</sup> UN Documents Gathering a body of global agreements. NGO Committee on Education. Retrieved 2<sup>nd</sup> June from < <http://www.un-documents.net/wced-ocf.htm> >

<sup>9</sup> Toolkit on Environmental Sustainability for the ICT Sector. International Telecommunication Union. Retrieved from [http://www.itu.int/dms\\_pub/itu-t/oth/4B/01/T4B010000060001PDFE.pdf](http://www.itu.int/dms_pub/itu-t/oth/4B/01/T4B010000060001PDFE.pdf). 2012

### People/citizens/society

The differentiating element between a digital city and a smart city is smart people. Key elements include skills, education level, life-long learning, and social integration in terms of human capital.<sup>10</sup>

### Quality of life/lifestyle

The World Health Organization (WHO) defines quality of life as "individuals' perception of their position in life in the context of the culture and value systems". These include their location in relation to goals, expectations, and concerns<sup>11</sup>.

### Governance/management/administration<sup>12</sup>

Smart governance includes political and active participation, citizenship services and the smart use of e-government.

### Economy/resources

Successful elements of the enterprise economy and the innovation/ideas economy are combined to form the smart economy. It also provides for a high-quality environment that focuses on the bettering of energy security and social cohesion.<sup>13</sup>

### Mobility

Smart mobility moves people and freight while enhancing economic, environmental, and human resources by emphasizing convenient and accessible multimodal travel (ensuring safety and operating at suitable speeds).<sup>14</sup>

## 5.3 Important terms to be included in a standardized definition

Based on all the analysis performed above, using the key categories and principle key word indicators, the following are 30 key terms which should be included in a standardized definition for a smart sustainable city.

---

<sup>10</sup> SMART CITIES STUDY: International study on the Situation of ICT, Innovation and Knowledge in cities. Iñaki Azkuna, Mayor of the City of Bilbao. Retrieved from [http://www.cities-localgovernments.org/committees/cdc/Upload/formations/smartcitiesstudy\\_en.pdf](http://www.cities-localgovernments.org/committees/cdc/Upload/formations/smartcitiesstudy_en.pdf)

<sup>11</sup> Programme on Mental Health: Measuring Quality of Life. Division of Mental Health and Prevention of Substance Abuse. World Health Organization. 1997. Retrieved from [http://www.who.int/mental\\_health/media/68.pdf](http://www.who.int/mental_health/media/68.pdf).

<sup>12</sup> <http://www.cities-localgovernments.org/committees/cdc/index.asp?IdPage=62>

<sup>13</sup> Building Ireland's Smart Economy – Government of Ireland 2008 Report Retrieved from [http://www.taoiseach.gov.ie/eng/Building\\_Ireland's\\_Smart\\_Economy/Building\\_Ireland's\\_Smart\\_Economy\\_-\\_Executive\\_Summary.pdf](http://www.taoiseach.gov.ie/eng/Building_Ireland's_Smart_Economy/Building_Ireland's_Smart_Economy_-_Executive_Summary.pdf)

<sup>14</sup> Smart City Mobility: a call to action for the new decade. United States Environmental Protection Agency. February 2010. Retrieved from [http://www.dot.ca.gov/hq/tpp/offices/ocp/smf\\_files/SMF\\_handbook\\_062210.pdf](http://www.dot.ca.gov/hq/tpp/offices/ocp/smf_files/SMF_handbook_062210.pdf).

**Table 4 – List of key terms to be included in a standardized definition for smart sustainable cities**

<ul style="list-style-type: none"> <li>▪ ICT</li> <li>▪ Adaptable</li> <li>▪ Reliable</li> <li>▪ Scalable</li> <li>▪ Accessible</li> <li>▪ Security</li> <li>▪ Safe</li> <li>▪ Resilient</li> <li>▪ Economic</li> <li>▪ Growth</li> </ul>	<ul style="list-style-type: none"> <li>▪ Standard of living</li> <li>▪ Employment</li> <li>▪ Citizens</li> <li>▪ Well-being</li> <li>▪ Medical</li> <li>▪ Welfare</li> <li>▪ Physical safety</li> <li>▪ Education</li> <li>▪ Environmental</li> <li>▪ Physical and service infrastructure</li> <li>▪ Transportation and mobility</li> </ul>	<ul style="list-style-type: none"> <li>▪ Water</li> <li>▪ Utilities and energy</li> <li>▪ Telecommunications</li> <li>▪ Manufacturing</li> <li>▪ Natural and man-made disasters</li> <li>▪ Regulatory and compliance</li> <li>▪ Governance</li> <li>▪ Policies and processes</li> <li>▪ Standardization</li> </ul>
---	---	--

## 6 Recommended definition

### 6.1 Criteria for definition

Based on a detailed analysis of the keywords in over 100 definitions of a smart sustainable city, it was found that the following criteria best define a smart sustainable city:

#### Key categories or groups

- ICT/communication/intelligence/information
- Infrastructure and services
- Environment/sustainable
- People/citizens/society
- Quality of life/lifestyle
- Governance/management/administration
- Economy/resources
- Mobility

#### Categories based on key indicators

- Smart living
- Smart people
- Smart environment and sustainability
- Smart governance
- Smart mobility
- Smart economy

### Key terms to be included

A set of 30 key terms were identified as essential to be included in the standardized definition for a *smart sustainable city*. This list is provided in section 5.3.

## 6.2 Specification

Based on the analysis discussed in this Technical Report, the following can form the basis for a specification for a "smart sustainable city".

A smart sustainable city is a city that leverages the ICT infrastructure in an adaptable, reliable, scalable, accessible, secure, safe and resilient manner in order to:

- Improve the quality of life of its citizens.
- Ensure tangible economic growth such as higher standards of living and employment opportunities for its citizens.
- Improve the well-being of its citizens including medical care, welfare, physical safety and education.
- Establish an environmentally responsible and sustainable approach which "meets the needs of today without sacrificing the needs of future generations".
- Streamline the physical infrastructure based services such as transportation (mobility), water, utilities (energy), telecommunications, and manufacturing sectors.
- Reinforce prevention and handling functionality for natural and man-made disasters including the ability to address the impacts of climate change.
- Provide an effective and well-balanced regulatory, compliance and governance mechanisms with appropriate and equitable policies and processes in a standardized manner.

## 6.3 Agreed definition of SSC

In October 2015, ITU-T Study Group 5 "Environment and Climate Change" and UNECE, based on the work of FG-SSC agreed on the following definition encompassing the major attributes of smart sustainable cities:

*"A smart sustainable city is an innovative city that uses information and communication technologies (ICTs) and other means to improve quality of life, efficiency of urban operation and services, and competitiveness, while ensuring that it meets the needs of present and future generations with respect to economic, social and environmental as well as cultural aspects".*



## 7 Conclusions

---

This Technical Report provides an insight into what is meant by a "smart sustainable city (SSC)" and the underlying factors that make a city smart.

- This Technical Report analysed approximately 120 existing definitions of smart sustainable cities from various sources to determine a common theme identifying a smart sustainable city.
- In addition, this Technical Report considered the key indicators and categories which should be taken into account for a smart sustainable city.
- A list of 30 key terms to be included in a standardized definition were also identified.
- Although this Technical Report is based on secondary data sources, it can be extremely useful to understand the concept of a smart sustainable city.
- Similarly, this Technical Report can form the basis of developing a standard definition of a global smart sustainable city and subsequently can be used to develop a framework to measure the performance of a smart sustainable city.
- Finally, a proposed comprehensive definition of a smart sustainable city has been presented.

## Annex 1 - Definitions of a smart sustainable city

\*Details of references are provided in Annex 2.

Ref. No.	Category	Definitions/Features	Key concept/ Keywords	Source
1	Academic	<p>A smart sustainable city is a city well performing in six (6) characteristics, built on the 'smart' combination of endowments and activities of self-decisive, independent and aware citizens:</p> <ul style="list-style-type: none"> <li>(i) Economy.</li> <li>(ii) Mobility.</li> <li>(iii) Environment.</li> <li>(iv) People.</li> <li>(v) Living.</li> <li>(vi) Governance.</li> </ul>	Economic growth, transport, mobility, environment, standard of living, governance.	Giffinger <i>et al.</i> (2007)
2	Academic	"We believe a city to be smart when investments in human and social capital and traditional (transport) and modern (ICT) communication infrastructure fuel sustainable economic growth and a high quality of life, with a wise management of natural resources, through participatory governance."	ICT, high quality of life, natural resource management, participatory governance, transport infrastructure, communication infrastructure, economic growth, sustainability.	Meijer <i>et al.</i> (2013)
3	Academic	The rudiments of what constitutes a smart sustainable city which we define as a city in which ICT is merged with traditional infrastructures, coordinated and integrated using new digital technologies.	Traditional infrastructure, ICT, integrated infrastructure, coordinated infrastructure, digital technology.	Batty <i>et al.</i> (2012)
4	Academic	<p>Instead of striving for physical growth, a city's success today should be measured by how wisely it uses energy, water, and other resources, how well it maintains a high quality of life for its people, and how smart it is in building prosperity on a sustainable foundation.</p> <p>In short, cities have to become much smarter about how they use the existing capacities and resources.</p>	Wise use of resources, quality of life, sustainability.	Dixon (2012)

Ref. No.	Category	Definitions/Features	Key concept/ Keywords	Source
5	Academic	<p>The Cellular City Compact, diverse, walk able and attractive cities are a luxury, but they should not be. The City Science Initiative at the MIT Media Lab is exploring technologies to help develop cities that facilitate the creation of desirable urban features, such as shared electric vehicles, adaptable living environments, and flexible work spaces.</p> <p>Our goal is to design urban cells that are compact enough to be walk able and foster casual interactions, without sacrificing connectivity to their larger urban surroundings. These cells must be sufficiently autonomous and provide resiliency, consistent functionality, and elegant urban design.</p> <p>Most importantly, the cellular city must be highly adaptable so it can respond dynamically to changes in the structure of its economic and social activities.</p>	Urban, technology, desirable features, shared electric vehicles, adaptable living environments, flexible work places, compact urban cells, elegant design, connected, autonomous adaptable dynamic.	Massachusetts Institute of Technology (2014)
6	Academic	<p>Tracing the genealogy of the word smart in the label smart sustainable city can contribute to an understanding of how the term smart is being loaded. In marketing language, smartness is centered on a user perspective.</p> <p>As a result of the need for appeal to a broader base of community members, smart serves better than the more elitist term intelligent. Smart is more user-friendly than intelligent, which is limited to having a quick mind and being responsive to feedback. Smart Sustainable City is required to adapt itself to the user needs and to provide customized interfaces.</p>	User perspective, user friendly, responsive, adaptability.	Nam <i>et al.</i> (2011)

Ref. No.	Category	Definitions/Features	Key concept/ Keywords	Source
7	Government	"A city that monitors and integrates conditions of all of its critical infrastructures including roads, bridges, tunnels, rails, subways, airports, sea-ports, communications, water, power, even major buildings, can better optimize its resources, plan its preventive maintenance activities, and monitor security aspects while maximizing services to its citizens."	Integrated infrastructure, resource optimization, preventive maintenance, monitors security, and maximizes services.	Hall <i>et al.</i> (2009)
8	Academic	<p>The term "smart city" is not used in a holistic way but with reference to various aspects which range from ICT districts to smart inhabitants in terms of their educational level. In addition, the term often refers to the relation between city government and citizens (e.g. good governance or smart governance). There is often a strong reference to the use of modern technology in everyday urban life, which includes innovative transport systems, infrastructures and logistics as well as green and efficient energy systems. Additional 'soft factors' connected to urban life for a Smart City include: participation, security/safety, cultural heritage.</p> <p>In conclusion, the literature review reveals the following main dimensions (or clusters of aspects):</p> <ul style="list-style-type: none"> <li>(i) smart governance (related to participation).</li> <li>(ii) smart human capital (related to people).</li> <li>(iii) smart environment (related to natural resources).</li> <li>(iv) smart living (related to the quality of life) and smart economy (related to competitiveness).</li> </ul>	Living, governance, economy, infrastructure, ICT, citizens, transport, energy, urban life.	Lombardi (2011)

Ref. No.	Category	Definitions/Features	Key concept/ Keywords	Source
9	Academic	The 'eco-cities' theme does not stand alone but is situated in a complex array of relevant variations of sustainable development, sustainable urban development, sustainable communities, bioregionalism, community economic development, appropriate technology, social ecology, green movement.	Ecology, technology, communities.	Roseland (1997)
10	Academic	A sustainable city is one in which its people and businesses continuously endeavour to improve their natural, built and cultural environments at neighbourhood and regional levels, whilst working in ways which always support the goal of global sustainable development.	Business, natural environment, built environment, cultural environment.	Haughton <i>et al.</i> (1994)
11	Academic	We say that a sustainable city is one in which the community has agreed on a set of sustainability principles and has further agreed to pursue their attainment.  These principles should provide the citizenry with a good quality of life, in a liveable city, with affordable education, health care, housing, and transportation.	Quality of life, lovable city, education, health care, housing	Munier (2007)
12	Academic	A sustainable city can broadly be defined as "one that has put in place action plans and policies that aim to ensure adequate resource availability and (re)utilization, social comfort and equity and economic development, and prosperity for future generations".	Policies, resource availability, social comfort, economic development, future generations.	Jingzhu (2011a)
13	Academic	A sustainable city is one that relates its use of resources and its generation and disposal of wastes to the limits imposed on such activities by the planet and its organisms.	Resources, waste, planet and organisms.	Jingzhu (2011b)



Ref. No.	Category	Definitions/Features	Key concept/ Keywords	Source
14	Academic	The basic feature of a sustainable city can be characterized as: facilitating economical uses of resources by technological and environmental improvements, targeting economic development, wealth building, social progress, and ecological security, maintaining a balance among resources, environment, information, interflow of material of the inner-outer urban system, meeting a city's future needs based on a correct assessment, and satisfying the present needs of urban development.	Technology, economic development, wealth, social progress, resources, information, urban development.	Jingzhu (2011c)
15	Academic	"Improving the quality of life in a city, including ecological, cultural, political, institutional, social, and economic components without leaving a burden on future generations".	Ecological, cultural, political, institutional, social and economic.	Jingzhu (2011d)
16	Academic	World Watch Institute considered that a city moving toward sustainability should improve public health and well-being, lower its environmental impacts, increase recycling its materials, and use energy with growing efficiency.	Public health, materials, recycle, energy efficiency.	Jingzhu (2011e)
17	Academic	A sustainable city is one that can provide and ensure sustainable welfare for its residents with the capacity of maintaining and improving its ecosystem services.	Residents, ecosystem services, welfare.	Jingzhu (2011f)
18	Academic	The urban ecosystem service can be generally defined as processes and conditions offered for people's survival and development by cities as social-economic-natural complex ecosystems.	People, survival, development, social, economic, natural.	Jingzhu (2011g)

Ref. No.	Category	Definitions/Features	Key concept/ Keywords	Source
19	Academic	A smart city is referred to as the safe, secure, environmentally green, and efficient urban centre of the future with advanced infrastructures such as sensors, electronics, and networks to stimulate sustainable economic growth and a high quality of life.	Safe, secure, environment, green, efficient, urban, future, infrastructure, sensor, electronics, networks, sustainability, economy, quality of life.	Schaffers <i>et al.</i> (2012a)
20	Academic	Major aspects highlighted in this paper balance different economic and social demands as well as the needs implied in urban development, while also encompassing peripheral and less developed cities.	Economic, social, urban development.	Schaffers <i>et al.</i> (2012b)
21	Academic	A smart city as a high-tech intensive and advanced city that connects people, information and city elements using new technologies in order to create a sustainable greener city, a competitive and innovative commerce and an increase in the quality of life with a straightforward administration and maintenance system of the city.	Advanced, high-tech, information, sustainability, green, competitive, innovation, commerce, quality of life, administration, maintenance.	Schaffers <i>et al.</i> (2012c)
22	Academic	A "smart city" is a city well performing in a forward-looking way in the six characteristics (smart economy, smart people, smart governance, smart mobility, smart environment, smart living) built on the 'smart' combination of endowments and activities of self-decisive, independent and aware citizens.	Citizens, economy, people, governance, mobility, environment, living.	Chourabi <i>et al.</i> (2012a)

Ref. No.	Category	Definitions/Features	Key concept/ Keywords	Source
23	Academic	A city "connecting the physical infrastructure, the IT infrastructure, the social infrastructure, and the business infrastructure to leverage the collective intelligence of the city".	Interconnected IT, social, business infrastructure.	Chourabi <i>et al.</i> (2012b)
24	Academic	A city striving to make itself "smarter" (more efficient, sustainable, equitable, and liveable).	Efficient, sustainable, equitable, liveable, standard of living.	Chourabi <i>et al.</i> (2012c)
25	Academic	Based on the exploration of a wide and extensive array of literature from various disciplinary areas, we identify eight critical factors of smart city initiatives: (i) management and organization. (ii) technology. (iii) governance. (iv) policy context. (v) people and communities, economy. (vi) built infrastructure. (vii) natural environment.	Technology, governance, policy context, people and communities, economy, built infrastructure, and natural environment.	Chourabi <i>et al.</i> (2012d)

Ref. No.	Category	Definitions/Features	Key concept/ Keywords	Source
26	Academic	<p>In general terms, we can define a "smart city" as a public administrative service or authority that delivers (or aims to deliver) a set of new generation services and infrastructure, based on information and communication technologies. Defining a new generation service is nevertheless a bit more complex and broader as the systems and services provided by smart cities should be easy to use, efficient, responsive, open and sustainable for the environment. The "smart city" concept brings together all the characteristics associated with organizational change, technological, economic and social development of a modern city.</p> <p>Moreover, smart city services and infrastructures entail the characteristics of engaging and interacting with the citizen that makes use of them. Another central element is the adaptive nature of services, ICT systems, infrastructures, buildings that comprehend the smart city concept. They acknowledge their initial status via a set of indicators and adapt their response according to the external changes that affect them. In doing so, they intelligently adapt to the external variables and demands that they are subject to, thus offering an always customized, more efficient and adaptive response.</p>	Technology, economic, social development, ICT, infrastructure, buildings.	González <i>et al.</i> (2011)

Ref. No.	Category	Definitions/Features	Key concept/ Keywords	Source
27	Corporate	Hitachi's vision for the "smart sustainable city" seeks to achieve concern for the global environment and lifestyle safety and convenience through the coordination of infrastructure. Smart sustainable cities realized through the coordination of infrastructures consist of two infrastructure layers that support consumers' lifestyles together with the urban management infrastructure that links these together using IT.	Coordinated infrastructure, lifestyle safety, lifestyle convenience, urban infrastructure, IT.	Hitachi (2014)
28	Corporate	A smarter city uses technology to transform its core systems and optimize finite resources. At the highest levels of maturity, a smarter city is a knowledge-based system that provides real-time insights to stakeholders, as well as enabling decision-makers to proactively manage the city's subsystems. Effective information management is at the heart of this capability, and integration and analytics are the key enablers.	Technology, transform, optimize finite resources, real-time information, decision-making information, information management, integration, analytics.	IBM (2013)
29	Corporate	Five (5) steps to make a city smart: (i) Vision: setting the goal and the roadmap to get there. (ii) Solutions: bringing in the technology to improve the efficiency of the urban systems. (iii) Integration: combining information and operations for overall city efficiency. (iv) Innovation: building each city's specific business model. (v) Collaboration: driving collaboration between global players and local stakeholders.	Urban systems, efficiency, technology, integration, innovation, efficiency.	Schneider Electric (2014)



Ref. No.	Category	Definitions/Features	Key concept/ Keywords	Source
30	Corporate	A "smart sustainable city" is one in which the seams and structures of the various urban systems are made clear, simple, responsive and even malleable via contemporary technology and design. Citizens are not only engaged and informed in the relationship between their activities, their neighbourhoods, and the wider urban ecosystems, but are actively encouraged to see the city itself as something they can collectively tune in, such that it is efficient, interactive, engaging, adaptive and flexible, as opposed to the inflexible, mono-functional and monolithic structures of many 20th century cities.	Urban system optimization, technology and design, informed citizens, citizen contribution, efficiency, interactive, adaptive, flexible.	ARUP (2011)
31	Corporate	Infrastructure, operations and people. What makes a city? The answer, of course, is all three. A city is an interconnected system of systems. A dynamic work in progress, with progress as its watchword. A tripod that relies on strong support for and among each of its pillars, to become a smarter city for all.	Interconnected systems, progress, infrastructure, operations, and people.	IBM (2014)

Ref. No.	Category	Definitions/Features	Key concept/ Keywords	Source
32	Corporate	<p>A city's attractiveness is directly related to its ability to offer the basic services that support growth opportunities, build economic value and create competitive differentiation. Potential inhabitants, of both the commercial and residential variety, are a discriminating lot, and they are looking for cities that operate efficiently and purposefully. They are looking for smarter cities. In particular, we are seeing the most advanced cities focus on three areas of expertise:</p> <ul style="list-style-type: none"> <li>(i) Leveraging information to make better decisions.</li> <li>(ii) Anticipating and resolving problems proactively.</li> <li>(iii) Coordinating resources to operate more efficiently.</li> </ul> <p>Forward-thinking cities are not waiting for better economic times to take action. They are focused on staying competitive, maximizing the resources at their disposal and laying the groundwork for transformation. They are redefining what it means to be a smarter city.</p>	Growth, economy, competitive differentiation, efficiency, purpose.	IBM (2012)
33	Corporate	<p>Replacing the actual city infrastructures is often unrealistic in terms of cost and time. However, with recent advances in technology, we can infuse our existing infrastructures with new intelligence. By this, we mean digitizing and connecting our systems, so they can sense, analyse and integrate data, and respond intelligently to the needs of their jurisdictions. In short, we can revitalize them so they can become smarter and more efficient. In the process, cities can grow and sustain quality of life for their inhabitants.</p>	Technology, connecting systems, analyse data, integrate data, responsive, efficient, growth, quality of life, sustainability.	IBM-India Needs Smart Cities (2014)

Ref. No.	Category	Definitions/Features	Key concept/ Keywords	Source
34	Corporate	<p>The "smart sustainable city" concept is really a framework for a specific vision of modern urban development. It recognizes the growing importance of information and communication technologies (ICTs) as drivers of economic competitiveness, environmental sustainability, and general liveability. By leveraging ICT as a core element of their development, the smart sustainable cities of the future will foster economic growth, improve the lifestyle of citizens, create opportunities for urban development and renewal, support eco-sustainability initiatives, improve the political and representative process, and provide access to advanced financial services.</p> <p>The right ICT infrastructure will affect the way each city will be created and evolved. It will enable smart sustainable cities to include vastly enhanced sustainable areas, such as smart buildings, smart infrastructures (water, energy, heat, and transportation) and smart services (e-substitutes and e-services for travel, health, education, and entertainment), which drastically change the urban experience for city dwellers and travellers.</p>	ICT, economy, environment, sustainability, quality of life, development, renewal, citizen representation, financial services, smart buildings, smart infrastructure, water, energy, heat, transportation, e-services.	Alcatel Lucent (2011)

Ref. No.	Category	Definitions/Features	Key concept/ Keywords	Source
35	Corporate	<p>The most effective definition of a smart sustainable city is a community that is efficient, liveable, and sustainable, and these three elements go hand-in-hand. Traditionally, water, gas, electricity, transportation, emergency response, buildings, hospitals, and public services systems of a city are separate and operate in silos independent of each other.</p> <p>A truly efficient city requires not only that the performance of each system is optimized but also that these systems are managed in an integrated way to better prioritize investment and maximize value. An efficient city also starts a community on the path to become competitive for talent, investment, and jobs by becoming more liveable.</p> <p>A city must work to become a pleasant place to live, work, and play. It must appeal to residents, commuters, and visitors alike. It must be socially inclusive, creating opportunities for all of its residents. It must provide innovative, meaningful services to its constituents. Liveability plays a critical role in building the talent pool, the housing market, and in providing cultural events which can bring memorable experiences, international attention, and investment to the community. A sustainable community is one which reduces the environmental consequences of urban life and is often an output of efforts to make the city more efficient and liveable. Cities are the largest contributors of carbon emissions; the highways, public spaces, and buildings we rely on to live, work, and play emit the bulk of each city's emissions. Implementing efficient, cleaner, and sustainable operations in all of these areas is critical to minimizing a city's environmental footprint.</p>	Efficient, quality of life, sustainability, integrated, services, natural resources, resource optimization, talent, investment, jobs, socially inclusive, innovative, low carbon, efficiency, regeneration.	Aoun-Schneider Electric (2014)

Ref. No.	Category	Definitions/Features	Key concept/ Keywords	Source
		Cities must also look at other methods of achieving sustainability, including resource efficiency, regenerating aging districts, ensuring robustness of systems, and incorporating design and planning in harmony with their natural ecosystem, as opposed to simply living in them.		
36	Corporate	A smart sustainable city is typically defined as "an environmentally conscious city that uses information technology (IT) to utilize energy and other resources efficiently."  In Hitachi's vision, a smart sustainable city is one that seeks to satisfy the desires and values of its residents, with the use of advanced IT to improve energy efficiency and concern for the global environment as prerequisites, and in so doing maintains a "well-balanced relationship between people and the Earth."	Environment, ICT, energy, resource management, efficiency, environment, values of citizens, desires of citizens.	Smart Cities: Hitachi (2014)



Ref. No.	Category	Definitions/Features	Key concept/ Keywords	Source
37	Corporate	<p>A city has common capabilities and delivers a set of common services, as well – office and residential buildings, natural resource management, transportation, health and safety, waste management, education and culture, public administration and services.</p> <p>One important characteristic that distinguishes an intelligent city is the manner in which it delivers services using advanced technologies: an integration of a number of innovations including machine-to-machine communication enabled by telematics, sensors and RFID technologies, smart grid technologies to enable better energy production and delivery, intelligent software and services, and high-speed communications technologies that serve as a core network for all related city, citizen and business services.</p>	Services, natural resource management, transportation, health, safety, waste management, education, culture, public administration, services, ICT, RFID, integrated, smart grid, energy, high speed communication.	Berton <i>et al.</i> Accenture (2014)
38	Corporate	<p>The 'Smart Community' is a next-generation community in which the management and optimized control of various infrastructures such as electricity, water, transportation, logistics, medicine, and information are integrated. The 'Smart Community' will provide comprehensive solutions encompassing energy, water, and medical systems in order to realize a synergetic balance between environmental considerations and comfortable living.</p>	Electricity, water, transportation, logistics, medicine, information, integrated, optimization, energy, comfortable living.	Takenaka- Toshiba (2012)

Ref. No.	Category	Definitions/Features	Key concept/ Keywords	Source
39	Corporate	We define a "smart sustainable city" as the city that uses information technology and communications to make both its critical infrastructure, its components and utilities offered more interactively, efficiently and where citizens are made more aware of them. It is a city committed to the environment, both environmentally and in terms of cultural and historical elements.	ICT, infrastructure, utilities, interactive, efficient, aware, environment, culture, history.	Telefónica (2014)
40	Corporate	A city that uses data, information and communication technologies strategically to: <ul style="list-style-type: none"> <li>(i) provide more efficient, new or enhanced services to citizens.</li> <li>(ii) monitor and track government's progress toward policy outcomes, including meeting climate change mitigation and adaptation goals.</li> <li>(iii) manage and optimize the existing infrastructure, and plan for a new one more effectively.</li> <li>(iv) reduce organizational silos and employ new levels of cross-sector collaboration, enable innovative business models for public and private sector service provision.</li> </ul>	Quality of life, authority, development, citizens, infrastructure.	Arup, Accenture, Horizon, University of Nottingham (2014)
41	Corporate	The "smart city" concept includes digital city and wireless city. In a nutshell, a smart city describes the integrated management of information that creates value by applying advanced technologies to search, access, transfer, and process information. A smart city encompasses e-home, e-office, e-government, e-health, e-education and e-traffic.	ICTs, quality of life, health, employment.	Huawei (2014)

Ref. No.	Category	Definitions/Features	Key concept/ Keywords	Source
42	Corporate	<p>A sustainable city is made up of three (3) main parameters to make sure that there is an overall development of energy, health care, buildings, transport, and water management in a city:</p> <ul style="list-style-type: none"> <li>(i) Environmental care – With right technologies, cities will become more environmentally friendly.</li> <li>(ii) Competitiveness – With the right technologies, cities will help their local authorities and businesses to cut costs.</li> <li>(iii) Quality of life – With the right technologies, cities will increase the quality of life for their residents.</li> </ul>	Quality of life, technologies, authorities, buildings, transport, water.	Siemens (2014)
43	Corporate	<p>As nations look to rebuild their aging infrastructures and at the same time take on the challenge of global climate change, Patel argues that resource usage needs to be at the heart of their thinking. We must also take a fundamental perspective in examining "available energy" in building and operating the infrastructure.</p> <p>Only if we use fewer resources to both build and run our infrastructures, he says, we will create cities that can thrive for generations to come. We can only build in that way, he suggests, if we seamlessly integrate IT into the physical infrastructure to provision the resources – power, water, waste, etc. – at a city scale based on the need.</p>	Infrastructure, energy, IT, power, water, waste.	Patel,-Hewlett Packard (2014)

Ref. No.	Category	Definitions/Features	Key concept/ Keywords	Source
44	Corporate	<p>One manifestation of the Oracle iGovernment vision is Oracle's Solutions for Smart Cities, which will address the ever increasing need to provide businesses and citizens with transparent, efficient and intelligent engagement with their local authority/administration – through any channel – for any purpose, from information requests and government programme enrolment, to incident reporting or scheduling inspections, to complete online start-up of a local business.</p> <p>Development, implementation and refinement of such a multichannel, single point-of-contact platform to all government organizations lays the foundation for a range of additional capabilities from business recruitment and retention to self-selecting, interest- and knowledge-based communities amongst citizens to improved management of civil contingencies and emergency disaster planning.</p>	Authority, information, business, development, citizens, disaster.	Oracle (2014)
45	Corporate	<p>A future where clean, efficient and decentralized energy will power a smart electricity grid to deliver power efficiently to millions of homes; a world not suffering from water scarcity where waste is seen as a resource; where citizens' mobility and health care needs are all taken care of by efficient and comprehensive systems; and where they can live in sustainable cities with green spaces, clean air and a high quality of life.</p>	Efficient, decentralized, energy, electricity, water, waste, green spaces, clean air and quality of life.	Dunlop (2012)

Ref. No.	Category	Definitions/Features	Key concept/ Keywords	Source
46	Corporate	<p>Urbanization, rapid population growth and shortages of resources are placing a new strain on city systems. So how can cities fuel economic growth whilst improving environment and social conditions? What must they do to raise service quality despite finite resources, and ever-growing demand? How can they work more effectively across the public sector, and with the private and 3rd sectors to transform outcomes? Smart technologies help city administrations tap into public information and create not just smarter, but more sustainable cities.</p>	Fuel economy, technology, administrations, sustainable.	Capgemini (2014)
47	Corporate	<p>"Smart Cities" are an effective response to today's needs which have become crucial. Thanks to the rapid, pressing trends seen throughout the world. In our view, the "smart city" is an urban model that minimizes efforts around "low level" needs and effectively satisfies "higher level" needs to guarantee an elevated quality of life while optimizing resources and areas for sustainability.</p>	Quality of life, optimization, resources, sustainability.	ABB Group (2014)
48	Corporate	<p>It takes more to build a smart city than simply using ICT to link and manage social infrastructure. Providing new values and services that residents truly need is also essential.</p> <p>Generating the knowledge to arrive at solutions by continuing to closely examine local issues, while putting this information into the equation when analysing the enormous amount of data from smartphones, various sensors, metres, and other devices, is a crucial task. Achieving it requires that Fujitsu put ICT to work to establish a sustainable social value cycle and create new innovations.</p>	Knowledge, solutions, sensors, data, ICT, innovations, infrastructure.	Fujitsu (2014)



Ref. No.	Category	Definitions/Features	Key concept/ Keywords	Source
49	Corporate	<p>The IBM vision for a smarter city uses technology to bring cities forward so that they can accomplish these types of objectives:</p> <ul style="list-style-type: none"> <li>(i) Quality of life for its citizens and visitors.</li> <li>(ii) A well-managed city works to create an optimal urban environment for its citizens, visitors, and industries by focusing on urban design, energy and water management, and an efficient and easy-to-use transportation system. These cities provide better performing and reliable city services that enable simplified and integrated access to services.</li> <li>(iii) A healthy and safe city addresses the health and safety of residents and visitors through innovations in local health care networks, disease management and prevention, social services, food safety, public safety, and individual information privacy.</li> <li>(iv) A sustainable city implements concrete measures toward sustainability through, for example, reduced consumption of energy and water and reduced emissions of CO<sub>2</sub>. Possible measures that can make a city sustainable include urban planning principles for mixed land use, architecture and construction principles for buildings, and methods to use rainwater instead of treated water.</li> </ul>	Quality of life, water and energy consumption, networks, information.	Kehoe-IBM (2011a)

Ref. No.	Category	Definitions/Features	Key concept/ Keywords	Source
		<p>(i) A city with good governance strives to improve the quality and efficiency of city services. It mandates transparency and accountability at all levels of the government. It provides the means to listen, understand, and respond to the needs of its citizens and businesses.</p> <p>(ii) A city that incorporates culture and events attracts visitors and keeps citizens interested in the city through investments in arts, culture, and tourism. These investments are a great way to draw attention to the city and a way to establish the city as a world-class location to live in.</p> <p>(iii) A city focused on its citizens looks to address their needs by providing information and access to city services in a convenient and easy-to-use manner. When done rightly, both the citizens and the city government can benefit. This mechanism gives the citizens access to the information and services when needed and gives the city a means to share important information and obtain input from its citizens in a timely manner.</p>		

Ref. No.	Category	Definitions/Features	Key concept/ Keywords	Source
50	Corporate	<p>Business growth and development, building the city's economy:</p> <ul style="list-style-type: none"> <li>(i) A city of digital innovation focuses on using strategic investments in connectivity and communications (for example, wireless broadband either broadcast or through hotspots). It attracts cutting edge businesses in the industrial and high-tech fields and builds human and intellectual capital.</li> <li>(ii) A city of commerce establishes itself as a local, regional, or national centre of commerce and economic development. It builds local expertise in a specific industry and the infrastructure and services to support continued growth and to remain competitive.</li> <li>(iii) A city attracting and keeping skilled workers promotes itself as being a desirable place to locate to or to grow up and stay in. This ability to maintain skilled workers is accomplished by anticipating and accommodating shifts in business needs, skills, local population, and demographics to offer economic opportunities.</li> <li>(iv) A city with free flowing traffic identifies and manages congestion actively. This demand is accomplished by making various forms of transport (such as road, air, rail, and bus) cost effective and efficient.</li> </ul>	Digital, commerce, building the city's economy, cost effective.	Kehoe-IBM (2011b)

Ref. No.	Category	Definitions/Features	Key concept/ Keywords	Source
51	Corporate	IBM defines a smarter city as one that makes optimal use of all the interconnected information available today to better understand and control its operations and optimize the use of limited resources.	Information, operations, resources, optimize.	IBM Smarter City Assessment Tool (2009)
52	Corporate	Smart cities: Innovative urban developments that leverage ICT for the management of natural energy consumption at the community level and other technologies to balance environmental stewardship with comfortable living.	Innovation, urban, ICT, energy, community, technology, environment, living.	Fujitsu (2014)
53	Corporate – Derived from video	<p>Cities are a complex and dynamic system. According to SAP, there are eight (8) fundamental factors that determine what defines a sustainable city:</p> <ul style="list-style-type: none"> <li>(i) Smart economy – long-term prosperity, innovation, entrepreneurs, and social business models.</li> <li>(ii) Good government – high performance.</li> <li>(iii) Open society.</li> <li>(iv) Resilience and sustainability – being clean and green.</li> <li>(v) Global attractiveness.</li> <li>(vi) Human and social capital.</li> <li>(vii) World-class financial expertise.</li> <li>(viii) Excellent infrastructure – physical and soft infrastructure (technology, research and knowledge).</li> </ul>	Smart economy, good government, open society, global attractiveness, human and social capital, infrastructure, knowledge, technology.	SAP (2014)

Ref. No.	Category	Definitions/Features	Key concept/ Keywords	Source
54	Corporate definition derived	Smart is a combination of collaborative leadership, policy and legal, customer insight, budget and performance management, service orientation and technology.	Leadership, policy, customer, service orientation, technology.	Colclough-Capgemini (2011)
55	Corporate CSR	In a broader definition, a city can be considered as "smart" when its investment in human and social capital and in communications infrastructure actively promotes sustainable economic development and a high quality of life, including the wise management of natural resources through participatory government.	Human capital, social capital, communication, economic growth, economic development, sustainability, quality of life, natural resource management, participatory government.	Hirst-European Investment Bank (2012)
56	Corporation	A smart city is a city that meets its challenges through the strategic application of ICT goods network and services to provide services to citizens or to manage its infrastructure.  A sustainable city is a city that meets the needs of the present without compromising the ability of future generations to meet their own needs.	ICTs, citizens, environment, social, economic growth.	Lovehagen-Ericsson (2013)
57	Government/ International organization	Traditionally, a "smart sustainable city" has been defined as a city that uses information and communication technology to make both its critical infrastructure, its components and utilities more interactive, efficient, making citizens more aware of them.	ICT, interactive critical infrastructure, interconnectivity, efficiency, awareness.	Azkuna (2012a)



Ref. No.	Category	Definitions/Features	Key concept/ Keywords	Source
58	Government/ International organization	<p>In preparing this report, we used the smart sustainable city model, which identifies the presence and convergence of six areas: economy, mobility, environment, citizenship, quality of life, and, finally, management.</p> <p>A city can be defined as smart when it displays a positive performance in these six areas, and when it has been built based on a "smart" combination of elements (communication, infrastructure, economic development) and on purposeful and independent citizen activities (participation, education) that make sound management of natural resources through participatory governance.</p>	Convergence, integration, economy, mobility, environment, citizenship, quality of life, communication, infrastructure, economic development, citizen participation, education, natural resource management, participatory governance.	Azkuna (2012b)
59	Government/ International organization	<p>A type of city that uses new technologies to make them more liveable, functional, competitive and modern, the promotion of innovation and knowledge management, bringing together six (6) key fields of performance: economy, mobility, environment, citizenship, quality of life and, finally, management.</p>	Liveable, technology, citizens, quality of life, management, economy.	Azkuna (2012c)
60	Government/ International organization	<p>Smart sustainable cities combine diverse technologies to reduce their environmental impact and offer citizens better lives. This is not, however, simply a technical challenge. Organizational change in governments – and indeed society at large – is just as essential. Making a city smart is therefore a very multidisciplinary challenge, bringing together city officials, innovative suppliers, national and EU policymakers, academics and civil society.</p>	Diverse technology, environment, quality of life, city officials, suppliers, policy makers, academics, civil society.	European Commission (2014)

Ref. No.	Category	Definitions/Features	Key concept/ Keywords	Source
61	Government/ International organization	A real smart city develops the city to reach the aim of improving the quality of life. It needs sound and innovative economic development as a means to reach this aim. Uses ICT as a tool with a great potential for ameliorating daily life, public services and the economy.	Quality of life, innovative, economic, ICT, public services.	Schweiker - Council of European Municipalities (2010)
62	Academic	Amsterdam Smart City uses innovative technology and the willingness to change behaviour related to energy consumption in order to tackle climate goals. Amsterdam Smart City is a universal approach for design and development of a sustainable, economically viable programme that will reduce the city's carbon footprint.	Smart city, innovative, technology, energy, economically, carbon footprint.	Lee <i>et al.</i> (2012)
63	Government/ International organization	There are three major functions that "ICT Smart Town" is expected to contain. ICT to be used both in ordinary times and in times of disaster. ICT is used in order to contribute to self-sustaining town development in ordinary times, while it functions for disaster prevention and mitigation in times of disaster. Users, mainly local citizens, can participate in the Smart Town community using the ICT system through user-friendly and accessible interfaces such as mobile phones and TVs. New services resulting from the use of "Big Data", including the government-held (public) data, private sector data and real-time data, collected through sensors.	Disaster, citizens, smart town, community, interfaces, government, real-time data.	Japan Ministry of Internal Affairs and Communications (2013)

Ref. No.	Category	Definitions/Features	Key concept/ Keywords	Source
64	Government/ International organization	Smart cities should be regarded as systems of people interacting with and using flows of energy, materials, services and finance to catalyse sustainable economic development, resilience, and high quality of life; these flows and interactions become smart through making strategic use of information and communication infrastructure and services in a process of transparent urban planning and management that is responsive to the social and economic needs of society.	People, quality of life, energy, materials, sustainable, economic, urban planning, society.	European Commission (2013)
65	Government/ International organization	A "city" can be defined smart when systematic information and communication technologies and resource-saving technologies are used to work towards a post fossil society, to reduce resource consumption, enhance permanently citizens' quality of life and the competitiveness of local economy – thus improving the city's sustainability.  The following areas are at least taken into account: energy, mobility, urban planning and governance. An elementary characteristic of a smart city is the integration and cross-linking of these areas in order to implement the targeted ecological and social aspects of urban society and a participatory approach.	Energy, mobility, urban planning, governance, integration, ecological, ICT.	Homeier-City of Vienna (2013)
66	Government/ International organization	Create a real shift in the balance of power between the use of information technology by business, government, communities and ordinary people who live in cities.	Power, information technology, business communications, government, people.	Deakin-European Commission (2014)

Ref. No.	Category	Definitions/Features	Key concept/ Keywords	Source
67	Corporate	<p>A smart city offers its inhabitants a maximum of life quality by a minimum use of resources thanks to intelligent combination of different infrastructure systems (transport, energy communication, etc.) on different levels like buildings, areas, quarters and cities.</p> <p>«Intelligent» in this context does not automatically mean "IT". By similar performance, passive or self-regulating mechanisms is preferable to active regulated systems.</p>	Quality of life, infrastructure systems, intelligence.	Horbaty-Energie Schweiz (2013)
68	Academic	"...are territories with a high capacity for learning and innovation, which is built into the creativity of their population, their institutions of knowledge creation and their digital infrastructure for communication". .... [and are concerned] with people and the human capital side of the equation, rather than blindly believing that IT itself can automatically transform and improve cities.	Learning, innovation, creative people, knowledge institutions, communication infrastructure.	Hollands (2008)
69	Industry association	The Council defines a Smart Sustainable City as one that has digital technology embedded across all city functions.	ICT, integrated, city functions.	Smart Cities Council (2014)
70	Government/ International organization	"At its core a smart city is a welcoming, inclusive city, an open city. By being forthright with citizens, with clear accountability, integrity, and fair and honest measures of progress, cities get smarter".	Integrity, citizens.	Comstock-World Bank Blogs (2012)
71	Internet	A developed urban area that creates sustainable economic development and high quality of life by excelling in multiple key areas: economy, mobility, environment, people, living, and government. Excelling in these key areas can be done through strong human capital, social capital, and/or ICT infrastructure.	Economic growth, standard of living, quality of life, transport, mobility, environment, governance, human capital, social capital, ICT, urban area.	Business Dictionary (2014)

Ref. No.	Category	Definitions/Features	Key concept/ Keywords	Source
72	Corporate	<p>Framing the "triple bottom line" of economy, environment, and social equity in one big picture. We are working to get our arms around a more sustainable future – a better way to connect people, homes, jobs and places – as a metro area and region, with more transportation choices.</p> <p>Frankly, it is a very tough challenge.</p>	Metro, economy, environment and social equity, transportation, interconnecting people, home, jobs and places.	Ott-HBR Blog Network (2011)
73	ITU	<p>A "smart sustainable city" is mainly based on the information and communication technologies. Through the transparent and full access to information, the extensive and secure transmission of information, the efficient and scientific utilization of information, SSC increases the urban operational and administrative efficiency, improves the urban public service level, forms the low-carbon urban ecological circle, and constructs a new formation of urban development.</p>	ICT, information access, information utilization, operational efficiency, administrative efficiency, services, low carbon, urban development.	FG-SSC-0005 (2014)

Ref. No.	Category	Definitions/Features	Key concept/ Keywords	Source
74	ITU	<p>Smart sustainable cities are well managed, integrated physical and digital infrastructures that provide optimal services in a reliable, cost effective, and sustainable manner while maintaining and improving the quality of life for its citizens. Key attributes of a smart sustainable city are mobility, sustainability, security, reliability, flexibility, technology, interoperability and scalability. Foundational aspects include economy, governance, society and environment with vertical infrastructures such as mobility, real estate and buildings, industrial and manufacturing, utilities - electricity and gas, waste, water and air management, safety and security, health care and education. All of these are woven into a single fabric with ICT infrastructure as a core.</p>	<p>Well managed, integrated, digital infrastructure, optimize services, sustainability, quality of life, mobility, security, reliability, flexibility, technology, interoperability, scalability, economy, governance, society, environment, real estate and buildings, industrial and manufacturing, utilities - electricity and gas, waste, water and air management, safety and security, health care and education, integrated, ICT.</p>	<p>FG-SSC-0013 (2014)</p>
75	ITU/ Government	<p>It is a city with a large, efficient and widespread technological network that fosters dialogue between citizens and everyday objects. It integrates the huge amount of information available to generate intelligence and improve daily life in a lifestyle that is increasingly "smart". It combines innovation with the environment, mobility and quality of life. It is a new phenomenon, complex and rapidly changing. Technological innovation moves in several directions (green buildings, smart mobility, e-health, e-government, etc.).</p>	<p>ICT, integrated, quality of life, innovation, environment, mobility, green buildings, health, environment governance.</p>	<p>FG-SSC-0014 (2013)</p>



Ref. No.	Category	Definitions/Features	Key concept/ Keywords	Source
76	ITU	ICT spans across a number of application sectors that characterize the framework of smart sustainable cities. Among others, energy, buildings, transport and mobility, water and waste management.	ICT, sustainability, energy, buildings, transport, mobility, water management, waste management.	FG-SSC-0020 (2013)
77	ITU	"A Smart Sustainable City has been defined as a 'knowledge', 'digital', and 'cyber' or 'eco' city; representing a concept open to a variety of interpretations, depending on the goals set out by a Smart Sustainable City's planners. We might refer to a Smart Sustainable City as an improvement on today's city both functionally and structurally, using information and communication technology (ICT) as an infrastructure. Looking at its functions as well as its purposes, a Smart Sustainable City can perhaps be defined as "a city that strategically utilizes many smart factors such as Information and Communication Technology to increase the city's sustainable growth and strengthen city functions, while guaranteeing citizens' happiness and wellness."	ICT, strategic resource utilization, sustainability, growth, services, citizen happiness, citizen wellness.	Hwang <i>et al.</i> (2013)
78	Magazine	Smart sustainable cities use information and communication technologies (ICT) to be more intelligent and efficient in the use of resources, resulting in cost and energy savings, improved service delivery and quality of life, and reduced environmental footprint – all supporting innovation and the low-carbon economy.	ICT, cost efficiency, energy efficiency, energy savings, quality of life, environment, improved service delivery, innovation, low carbon economy.	Cohen (2011)

Ref. No.	Category	Definitions/Features	Key concept/ Keywords	Source
79	Magazine	<p>An eco-city is defined as a city in which citizens, business and government sustainably work, live and interact through delivery of integrated, low carbon products and services. The objective of this project is to build a new industrial community to maximize the welfare of the people and minimize carbon emission.</p> <p>The above vision can be achieved by integrating technology across water, waste, energy, transportation and safety infrastructure while taking measures like maximum utilization of renewable resources for electricity supply, minimum loss of natural resources and others.</p>	Sustainably, integrated, low carbon products and services, maximize welfare, industrial community, integrated technology.	Manesar (2011)
80	User centric	"The use of Smart Computing technologies to make the critical infrastructure components and services of a city-which include city administration, education, healthcare, public safety, real estate, transportation, and utilities-more intelligent, interconnected, and efficient".	Computing technologies, interconnected components, city administration, education, healthcare, public safety, real estate, transportation, utilities, efficiency.	Washburn <i>et al.</i> (2010)
81	User centric	A smart sustainable city is characterized by the integration of technology into a strategic approach to sustainability, citizen well-being, and economic development.	ICT, integrated, sustainability, citizen well-being, economic development.	Woods <i>et al.</i> (2013)
82	User centric	The terms "smart" and "intelligent" have become part of the language of urbanization policy, referring to the clever use of IT to improve the productivity of a city's essential infrastructure and services and to reduce energy inputs and CO <sub>2</sub> outputs in response to global climate change.	ICT, infrastructure productivity, services, low carbon, environment.	Hodkinson, S. (2011)

Ref. No.	Category	Definitions/Features	Key concept/ Keywords	Source
83	User centric	A smart sustainable city is one that "uses information and communications technologies to make the critical infrastructure components and services of a city – administration, education, healthcare, public safety, real estate, transportation and utilities – more aware, interactive and efficient."	ICT, administration, education, health care, public safety, real estate, transportation, utilities, integrated, efficient, interactive.	Belissent (2010)
84	User centric	An urbanized area where multiple public and private sectors cooperate to achieve sustainable outcomes through the analysis of contextual information exchanged between them. The sectors could include hospitals or emergency services or finance and so on. The interaction between sector-specific and intra-sector information flows results in more resource-efficient cities that enable more sustainable citizen services and more knowledge transfer between sectors.	Information exchange, integrated, resource efficiency, services, sustainability.	Maio (2012)
85	User centric	Cities need to differentiate themselves to attract investment and productive residents, and this is coupled with constrained financial resources, fast-growing populations, and aging infrastructures, is driving investment in smart sustainable city solutions. Smart sustainable city solutions leverage ICT not only to deliver higher-quality citizen services more efficiently but also to effect behavioural change in government workers, city businesses, and citizens so that cities can develop more sustainably.	ICT, services, efficient, development and behavioural change in government workers, city businesses, and citizens.	IDC (2014)

Ref. No.	Category	Definitions/Features	Key concept/ Keywords	Source
86	User centric	<p>It is precisely because of the importance of cities and the need to deepen knowledge of urban issues that we undertake the study. The effort to question and understand where cities are and where they are headed benefits all of us in a world urbanizing like never before. This includes the officials and policymakers setting the course, businesses invested in city well-being, and the citizens who build their lives in thousands of city neighbourhoods worldwide, rich or poor, picturesque or prosaic.</p>	<p>Policymakers, business, well-being, urbanizing.</p>	<p>Ernst &amp; Young (2014)</p>
87	User centric	<p>Many cities are exploring the "Smart City" or "Intelligent Community" concept to improve efficiencies, optimize how they use largely finite resources and become better places to live and make business. They are deploying new information and communications technology to strengthen social and business services across different sectors and to build an intelligent digital nervous system supporting urban operations.</p> <p>By incorporating information and communications technology and strategically exploiting the vast amounts of data they generate, smart cities can make buildings more efficient, reduce energy consumption and waste, and make better use of renewable energy. They can manage traffic intelligently, monitor how infrastructure performs, provide better communications infrastructures, deliver services much more efficiently, and enhance citizens' access to government.</p>	<p>Social, business, efficient, renewable, monitor, infrastructure, citizens, government, ICT, energy consumption.</p>	<p>Craren <i>et al.</i> (2012a)</p>

Ref. No.	Category	Definitions/Features	Key concept/ Keywords	Source
88	User centric	<p>What makes a city tick? "Justice remains the appropriate name for certain social utilities which are vastly more important, and therefore more absolute and imperative, than any others," John Stuart Mill wrote in <i>Utilitarianism</i> in 1861. He added, "education and opinion, which have so vast a power over human character, should so use that power to establish in the mind of every individual an indissoluble association between his own happiness and the good of the whole."</p> <p>Many of those we spoke with this year in developing Cities of Opportunity agree. The foundations of healthy cities remain rule of law and safety and security today, as well as strong education to foster those qualities for future generations.</p>	Justice, education, happiness, healthy, security, safety.	Craren <i>et al.</i> (2012b)
89	User centric	<p>Smart city is characterized by the integration of technology into a strategic approach to sustainability, citizen well-being, and economic development. Smart city projects span several industry and operational silos: energy, water, transportation, buildings management, and government services.</p> <p>Most importantly, the smart city concept promotes new integrated approaches to city operations, leading to innovation in cross-functional technologies and solutions.</p>	Technology, well-being, economic development, energy, water, transportation, buildings, government, innovation, technology.	Woods <i>et al.</i> (2013)

Ref. No.	Category	Definitions/Features	Key concept/ Keywords	Source
90	User centric	<p>According to Deloitte the three market drivers of smart cities are smart water, smart energy and smart agriculture. Smart water is increasingly seen as a component of ambitious smart city programmes that address the myriad of problems created by mass urbanization.</p> <p>Smart energy – the race for more and more energy sources is driving an increase in unconventional oil and gas exploration – in turn driving significant water and wastewater issues. Smart agriculture – the challenge to feed a growing global population is stressing food systems in both the developed and developing world and requires novel agricultural solutions.</p>	Solutions, water, agriculture, energy, population.	Haji (2013)



Ref. No.	Category	Definitions/Features	Key concept/ Keywords	Source
91	User centric	<p>The definition of sustainable development comprises five categories:</p> <ul style="list-style-type: none"> <li>(i) Basic needs: Access to safe water, sufficient living space, adequate health care, and education are fundamental priorities for urban populations.</li> <li>(ii) Resource efficiency: A city's efficiency in such areas as the use of water and energy and the effective recycling of waste directly correlates to the quality of life of its citizens.</li> <li>(iii) Environmental cleanliness: Limiting exposure to harmful pollutants is fundamental to a city's liveability.</li> <li>(iv) Built environment: Equitable access to green space, public transportation, and dense, efficient buildings makes communities more liveable and efficient.</li> <li>(v) Commitment to future sustainability. An increase in the number of employees and the level of financial resources devoted to sustainability suggests how committed city governments are to implementing national and local policies and standards.</li> </ul>	Water, living space, health care, urban populations, energy, recycling, quality of life, pollutants, cleanliness, efficient, policies and standards.	Bouton <i>et al.</i> (2012)

Ref. No.	Category	Definitions/Features	Key concept/ Keywords	Source
92	Non-profit	A city "combining ICT and Web 2.0 technology with other organizational, design and planning efforts to de-materialize and speed up bureaucratic processes and help to identify new, innovative solutions to city management complexity, in order to improve sustainability and liveability."	ICT, web 2.0, bureaucratic efficiency, city management, innovative solutions, sustainability, liveability, standard of living.	Toppeta (2010)
93	Conference	<p>What makes a city smart? A non-vendor driven definition of a 'Smart Sustainable City'</p> <p>The closer a city behaves to the ethos of the Internet, the smarter it is. That means the city is a platform – an enabler for the people. So, empowering people is at the centre of the perfect storm.</p> <p>So, what does a smart sustainable city look like? A city can be defined as smart when investments in human and social capital and traditional (ex-transport) and modern (ex-ICT) communications infrastructure fuel sustainable economic development and a high quality of life with a wise management of natural resources through participatory governance.</p>	People enabler, human capital, social capital, traditional communication, modern communication, ICT, economic development, quality of life, natural resource management, participatory governance.	Jaokar (2012)

Ref. No.	Category	Definitions/Features	Key concept/ Keywords	Source
94	Others	<p>Seven (7) important elements in most cases of a smart sustainable city (Source: Xi She):</p> <ul style="list-style-type: none"> <li>(i) sensible – sensor sensing the environment.</li> <li>(ii) connectable – networking devices bringing the sensing information to the web.</li> <li>(iii) accessible – the broader information of our environment is published on the web, and is accessible to the user on the web, (web).</li> <li>(iv) ubiquitous – the user can access information through the web, but more importantly through the use of the mobile (mobile).</li> <li>(v) social – the user acquires the information, and publishes it through his social network (social network).</li> <li>(vi) sharing – sharing is not limited to data but also to the physical object, when some objects are in free status, people can get the notification and use it. (web, mobile).</li> <li>(vii) visibility/augmented – to retrofit the physical environment, make the hidden information seen not only through the mobile device by individuals but also with the naked eyes in a more border range like street signs.</li> </ul>	Sensor monitoring, Internet connectivity, information availability, mobile, visible.	World Smart Capital (2012)

Ref. No.	Category	Definitions/Features	Key concept/ Keywords	Source
95	Industry	A smart city is a city that employs ICT infrastructures by sensing, transmitting and utilizing information in order to fulfil information sharing and service collaboration, further improve citizens' livelihood standards and their quality of life, increase urban operation efficiency and public service level, enhance the quality of economic development and industry competitive ability, and realize the scientific and sustainable development of the city.	Sensing, transmitting, ICT infrastructure, information, collaboration, quality of life, urban efficiency, economy, competitive, scientific, sustainable.	China Communication Standards Association (2014)
96	Government	Smart cities should be regarded as systems of people interacting with and using flows of energy, materials, services and finance to catalyse sustainable economic development, resilience, and high quality of life; these flows and interactions become smart through making strategic use of information and communication infrastructure and services in a process of transparent urban planning and management that is responsive to the social and economic needs of society.	Systems, people, energy, materials, services, finance, sustainable, economic, resilience, quality of life, ICT infrastructure, urban planning, responsive, social.	European Innovation Partnership on Smart Cities and Communities
97	Academic	Main features to be included in smart city administration: (i) Quality of life. (ii) Sustainable resource management. (iii) Cultural facilities. (iv) Health facilities. (v) Sustainable and innovative and safe transport systems. (vi) Environmental protection.	QoL, resources, sustainability, environment, health, transport, mobility.	Vienna University of Technology, University of Ljubljana, Delft University of Technology (2007)

Ref. No.	Category	Definitions/Features	Key concept/ Keywords	Source
98	Academic	Eco-cities focus on: (i) entrepreneurship. (ii) environment. (iii) sustainable urban development.	Business, environment, sustainability.	Rapoport, E. (2014)
99	Academic	Smart cities should focus on: (i) improvement of urban living capacity. (ii) resource efficient development. (iii) low carbon economy. (iv) use of ICT to manage complex urban system.	Urban, resources, economy, people.	Alusi, A., Eccles, R. G., Edmondson, A. C., Zuzul, T. (2011)
100	Academic	Smart city triple helix: human and social relations connecting the intellectual capital, natural wealth and governance of their regional development.	People, intelligent, development, governance and administration, natural, resources.	Njikamp, Lombardi, P., Giordano, S., Caraglui, A., Del Bo, C., Deakin, M.
101	Academic/ Corporate	Key aspect of smart cities is a plan for efficient management of utilities enabled by technologies such as those entailing smart metering of the residential consumption of electricity, water or gas.	Technology, utilities, efficient, water, electricity.	Monedero, D. R., Bartoli, A., Hernandez-Saerrano, J., Forne, J., Soriano, M. (2013)
102	Academic	Features of smart cities involve the use of discrete future Internet technologies (RFID), improving e-governance, providing and environment for innovation.	ICT, technology, governance and administration.	Balloon, Pieter, Glidden, J., Kranas, P., Menychtas, A., Ruston, S., Van der Graaf, S. (2011)

Ref. No.	Category	Definitions/Features	Key concept/ Keywords	Source
103	Academic	<p>Typology of smart city functions:</p> <ul style="list-style-type: none"> <li>(i) Smart economy (competitiveness): innovative spirit, entrepreneurship, economic image, productivity.</li> <li>(ii) Smart mobility (transport and ICT): local accessibility, availability of ICT infrastructure, innovative and safe transport systems.</li> <li>(iii) Smart people (social and human capital): level of qualification, flexibility, creativity, participation in public life.</li> <li>(iv) Smart environment (natural resources): pollution control, environmental protection, sustainable resource management.</li> <li>(v) Smart governance (participation): decision-making, transparent governance, political strategies and perspectives.</li> <li>(vi) Smart living (quality of life): cultural activities, health conditions, housing quality, education facilities, touristic attractiveness, social cohesion.</li> </ul>	Economy, business, competition, mobility, transport, social, people, capital, society, environment, sustainable, resources, natural, efficient, governance and administration, QoL, education, health, buildings.	Batty, M. Axhausen, K. W., Giannotti, F., Pozdnoukhov, A., Bazzani, A., Wachowicz, M., Ouzounis, G., Portugali, Y. (2012)
104	Academic	Smart cities should be centred around ecological modernization with an emphasis on business opportunities associated with a move to low carbon economy.	Environment, business, resources, efficient, economy.	Antrobus, D. (2011)



Ref. No.	Category	Definitions/Features	Key concept/ Keywords	Source
105	Academic	<p>"Smarter cities" has the following four components:</p> <ul style="list-style-type: none"> <li>(i) the application of a wide range of electronic and digital technologies to communities and cities.</li> <li>(ii) the use of information technologies to transform life and work within a region.</li> <li>(iii) the embedding of such ICTs in the city.</li> <li>(iv) the territorialisation of such practices in a way that brings ICTs and people together so as to enhance innovation, learning, knowledge and problem solving that the technologies offer.</li> </ul>	ICT, technology, QoL, community, public, innovations, society, intelligent.	Allwinkle, S., Cruickshank, P. (2011)
106	Academic	Urban dwellers should be provided with smart phones that provide advanced capabilities to connect to the Internet, determine the user's location as well as provide crowd-sourcing platforms.	Public, ICT, community, participatory, actively, accessible, mobility.	Benouret, K., Ramalingam, R. V., Charoy, F. (2013)
107	Academic	"A smart city is generally meant as a city capable of joining competitiveness and sustainability by integrating different dimensions of development and addressing infrastructural investments able to support economic as well as the quality of life of communities, a more careful management of natural resources, a greater transparency and participation to the decision making process."	Sustainable, participatory, society, quality of life, integrate, resources, competitive, investment, economy, community, transparency, active, development.	Papa, R. (2013)

Ref. No.	Category	Definitions/Features	Key concept/ Keywords	Source
108	Academic	<p>Findings denote that smart cities should include the following dimensions:</p> <ul style="list-style-type: none"> <li>(i) Urban openness: making information visually available, participatory services to drive civic engagement.</li> <li>(ii) Service innovation: using ICTs to drive development in health, welfare, education, transportation, sectors, etc.</li> <li>(iii) Partnership formation: partnerships for building effective smart cities (central government, state government, private bodies, NGO involvement), direct vs indirect involvement, contracted/outsourcing development.</li> <li>(iv) Smart city integration: smart service access over multiple device platforms, app-based formatting of service information.</li> <li>(v) Smart city governance: Smart city teams involved with strategy, policy, and infrastructure and include ICT-based performance evaluation and feedback channels.</li> </ul>	Accessible, participatory, ICT, governance and administration, investments, transport, business, health security and safety, urban, design, innovation.	Lee, J. H. Hancock, M. G., Hu, M. (2012)

Ref. No.	Category	Definitions/Features	Key concept/ Keywords	Source
109	Corporate	IBM Smarter Cities Initiative: <ul style="list-style-type: none"> <li>(i) is a long term process aiming to transform city based technologies and, in the process, help cities achieve their strategic vision.</li> <li>(ii) recognizes that the needs and aspirations of each city may be very different.</li> <li>(iii) requires partnerships (across many clients and with other delivery partners) to achieve the desired large scale transformations.</li> <li>(iv) is based heavily on dimensions from IBM's global Smarter Planet strategy of which there are many applications (smart education systems, cloud computing, risk assessments, ICT based platform for exchange of ideas etc.).</li> </ul>	Vision, solutions, design, management, business, education, ICT, technology.	Paroutis. S., Bennett, Heracleous, L. (2012)
110	Academic	"The basic concept of the Smart Cities initiative can be expressed as follows: the Smart Cities initiative seeks to improve urban performance by using data, information and IT to provide more efficient services to citizens to monitor and optimize existing infrastructure, to increase collaboration between economic actors and to encourage innovative business models in both public and private sectors."	Urban, ICT, innovation, people, economy, business, public, information, management, services.	Llacuna, M. L. M. Llinas, J. C., Frigola, J. M. (2014)
111	Academic	Five successful factors for a smart city: <ul style="list-style-type: none"> <li>(i) broadband connectivity.</li> <li>(ii) knowledge workforce.</li> <li>(iii) digital inclusion.</li> <li>(iv) innovation.</li> <li>(v) marketing.</li> <li>(vi) advocacy.</li> </ul>	ICT, education, technology, innovation, business, communication.	Kramers, A., Hojer, M., Lovehagen, N., Wangel, J. (2014)

Ref. No.	Category	Definitions/Features	Key concept/ Keywords	Source
112	Academic	<p>"The concept of Smart City as a means to enhance the life quality of citizen has been gaining increasing importance in the agendas of policy makers".</p> <p>The main domains of a smart city include:</p> <ul style="list-style-type: none"> <li>(i) Employing ICT to deliver energy, enhance entrepreneurship and enable information exchange about consumption between providers and users with the aim of reducing costs and increasing reliability and transparency of energy supply systems.</li> <li>(ii) Public lighting, natural resources and water management.</li> <li>(iii) Waste management: Using innovations to manage waste generated by people, businesses and city services. This includes waste collection, disposal, recycling and recovery.</li> <li>(iv) Environment: Technology used to manage environmental resources and related infrastructure. This is done with the aim of improving sustainability.</li> <li>(v) Transport: Using sustainable public transportation based on environmentally friendly fuels and innovative propulsion systems.</li> <li>(vi) Healthcare: ICT applications and remote assistance to prevent and diagnose diseases. Improved access to health care systems.</li> <li>(vii) Public security: Use of ICT to assist with security issues like fire. ICTs may also be of help to the police department.</li> <li>(viii) Education and culture: Using ICTs to create opportunities for students and teachers, promote cultural events, manage tourism and hospitality.</li> </ul>	Energy, economy, resources, management, water, environment, participatory, governance and administration, business, health security and safety, education, intelligent, ICT, innovation, natural, public, management, transport, utilities.	Neirotti, P., De Marco, A., Cagliano, A. C., Mangano, G., Scorrano, F. (2014)

Ref. No.	Category	Definitions/Features	Key concept/ Keywords	Source
		(ix) Public administration and governance: Promoting digitalized public administration, e-ballots and ICT-based transparency of government activities to enhance the empowerment of the inhabitants and involvement in administration.		
113	Corporate	Smart cities are aimed at: (i) addressing urbanization. (ii) facilitating economic growth, enhancing technological progress using ICTs. (iii) environmental sustainability.	Urban, ICT, environment, innovation, technology.	Naphade, M., Guruduth, B., Harrison, C., Jurij, P., Morris, R. (2014)
114	Academic/International organization	Smart city establishments include: (i) Energy policy management. (ii) Healthcare governance. (iii) Financial policy management. (iv) Remote monitoring. (v) Complaint management. (vi) Intelligent buildings. (vii) Security systems based on ICT,IT configuration management databases.	Energy, health, security and safety, intelligent, ICT, management, buildings.	Asimakopoulou, E., Bessis, N. (2011)
115	Academic	"A city that monitors and integrates conditions of all the its critical infrastructures, including roads, bridges, tunnels, rails subways, airports, seaports, communications, water, power, even major buildings can better optimize its resources, plan its preventive maintenance activities, and monitor security aspects while maximizing services to its citizens."	Transport, energy, resources, society, integration.	Hall, R., E. (2000)
116	Academic	"A city striving to make itself smarter (more efficient, sustainable, equitable and livable)."	Sustainable, QoL, society, ICT, technology.	Nfuka, E., N., Rusu, L. (2010)

## Annex 2 - References for definitions

---

1. Giffinger, Rudolf, *et al. Smart Cities Ranking of European Medium-sized Cities*, Centre of Regional Science, Vienna UT, Oct. 2007. Page 10. Web. Last accessed 8 Feb. 2014. [http://www.smart-cities.eu/download/smart\\_cities\\_final\\_report.pdf](http://www.smart-cities.eu/download/smart_cities_final_report.pdf).
2. Meijer, Albert, and Bolívar, Manuel Pedro Rodríguez, *Governing the Smart Sustainable City: Scaling-Up the Search for Socio-Techno Synergy*, T EGPA 2013 (Edinburgh, September) Permanent Study Group on E-Government, 2013, Web. Last accessed 8 Feb. 2014. [https://www.scss.tcd.ie/disciplines/information\\_systems/egpa/docs/2013/BolivarMeijer.pdf](https://www.scss.tcd.ie/disciplines/information_systems/egpa/docs/2013/BolivarMeijer.pdf)
3. Batty, Michael, Axhausen, Kay, Fosca, Giannotti, Pozdnoukhov, Alexei, Bazzani, Armando, Wachowicz, Monica, Ouzounis, Georgios, and Portugali, Yuval, *CASA Working Paper 188 – Smart Cities of the Future*, The Bartlett Centre for Advanced Spatial Analysis – UCL, 05 Oct. 2012. Web. Last accessed 8 Feb. 2014. <http://www.bartlett.ucl.ac.uk/casa/publications/working-paper-188>.
4. Dixon, Michael J., *How Smart Cities Save Money (and the Planet)*, Harvard Business Review, HBR Blog Network, 29 Oct. 2012. Web. Last accessed 8 Feb. 2014. [http://blogs.hbr.org/cs/2012/10/tech-savvy\\_cities\\_are\\_saving\\_m.html](http://blogs.hbr.org/cs/2012/10/tech-savvy_cities_are_saving_m.html).
5. *About City Science*, MIT Cities, Massachusetts Institute of Technology, 2012. Web. Last accessed 8 Feb. 2014. <http://cities.media.mit.edu/about/cellular-city>.
6. Nam, Taewoo, and Pardo, Theresa A., *Conceptualizing Smart Sustainable City with Dimensions of Technology, People, and Institutions*, The Proceedings of the 12th Annual International Conference on Digital Government Research, June 2011. Web. Last accessed 8 Feb. 2014. [http://www.ctg.albany.edu/publications/journals/dgo\\_2011\\_smartcity/dgo\\_2011\\_smartcity.pdf](http://www.ctg.albany.edu/publications/journals/dgo_2011_smartcity/dgo_2011_smartcity.pdf)
7. Hall, R. E., Bowerman, B., Braverman, J., Taylor, J., Todosow, H., and Von Wimmersperg, U., *The Vision of a Smart Sustainable City*, SciTech Connect: U.S. Department of Energy, Office of Scientific and Technical Information (OSTI), 28 Sept. 2009. Web. Last accessed 8 Feb. 2014. <http://www.osti.gov/scitech/servlets/purl/773961>.
8. Lombardi, Patrizia, *New Challenges in the Evaluation of Smart Cities*, Network Industries Quarterly, Vol. 13, 2011. Web. Last accessed 8 Feb. 2014. <http://newsletter.epfl.ch/mir/index.php?module=epflfiles&func=getFile&fid=241&inline=1>.
9. Roseland, Mark, *Dimensions of the Eco-city*, Dimensions of the Eco-city, Pergamon, Aug. 1997. Web. Last accessed 8 Feb. 2014. [http://www.sze.hu/fk/kornyezet/Cikkek2/Dimensions-of-the-eco-city\\_1997\\_Cities.pdf](http://www.sze.hu/fk/kornyezet/Cikkek2/Dimensions-of-the-eco-city_1997_Cities.pdf).
10. Houghton, G., and Hunter, C., *Sustainable Cities*, London: Jessica Kingsley and Regional Studies Association, 1994. <http://www.civ.utoronto.ca/sir/>.
11. Munier, Nolberto, *Handbook on Urban Sustainability*, Springer, 2007. Web. 15 Feb. 2014. <http://www.springer.com/environment/environmental%2Bmanagement/book/978-1-4020-5350-4>.
12. Zhao, Jingzhu, *Towards Sustainable Cities in China*, SpringerBriefs in Environmental Science, Springer, 2011a. Page 2. Web. Last accessed 8 Feb. 2014. <http://link.springer.com/book/10.1007%2F978-1-4419-8243-8>



13. Zhao, Jingzhu, *Towards Sustainable Cities in China*, SpringerBriefs in Environmental Science, Springer, 2011b. Page 2. Web. Last accessed 8 Feb. 2014.  
<http://link.springer.com/book/10.1007%2F978-1-4419-8243-8>
14. Zhao, Jingzhu, *Towards Sustainable Cities in China*, SpringerBriefs in Environmental Science, Springer, 2011c. Page 3. Web. Last accessed 8 Feb. 2014.  
<http://link.springer.com/book/10.1007%2F978-1-4419-8243-8>
15. Zhao, Jingzhu, *Towards Sustainable Cities in China*, SpringerBriefs in Environmental Science, Springer, 2011d. Page 2. Web. Last accessed 8 Feb. 2014.  
<http://link.springer.com/book/10.1007%2F978-1-4419-8243-8>
16. Zhao, Jingzhu, *Towards Sustainable Cities in China*, SpringerBriefs in Environmental Science, Springer, 2011e. Page 2. Web. Last accessed 8 Feb. 2014.  
<http://link.springer.com/book/10.1007%2F978-1-4419-8243-8>
17. Zhao, Jingzhu, *Towards Sustainable Cities in China*, SpringerBriefs in Environmental Science, Springer, 2011f. Page 2. Web. Last accessed 8 Feb. 2014.  
<http://link.springer.com/book/10.1007%2F978-1-4419-8243-8>
18. Zhao, Jingzhu, *Towards Sustainable Cities in China*, SpringerBriefs in Environmental Science, Springer, 2011g. Page 2. Web. Last accessed 8 Feb. 2014.  
<http://link.springer.com/book/10.1007%2F978-1-4419-8243-8>
19. Schaffers, Hans, Komninos, Nicos, *et al. Landscape and Roadmap of Future Internet and Smart Cities*, 17 April 2012. Web. Last accessed 9 Feb. 2014.  
[http://hal.inria.fr/docs/00/76/97/15/PDF/FIREBALL\\_D2.1\\_M24.pdf](http://hal.inria.fr/docs/00/76/97/15/PDF/FIREBALL_D2.1_M24.pdf)
20. Schaffers, H., Komninos, N., Pallot, M., Trousse, B., Nilsson, M., *Smart cities and the Future Internet: Towards Cooperation Frameworks for Open Innovation*, 2011a (page 172). Web. Last accessed 15 Feb. 2014. <http://www-sop.inria.fr/axis/pages/bestpaper/FIA2011t.pdf>.
21. Schaffers, H., Komninos, N., Pallot, M., Trousse, B., Nilsson, M., *Smart cities and the Future Internet: Towards Cooperation Frameworks for Open Innovation*, 2011b (page 172). Web. Last accessed 15 Feb. 2014. <http://www-sop.inria.fr/axis/pages/bestpaper/FIA2011t.pdf>.
22. Chourabi, Hafedh, Nam, Taewoo, Walker, Shawn, Gil-Gracia, Ramon J., Mellouli, Sehl, Nahon, Karine, Prado, Theresa A., and Scholl, Hans Jochen, *Understanding Smart Cities: An Integrative Framework*, Hawaii International Conference on System Sciences, 2012a. Page 2290. Web. Last accessed 9 Feb. 2014.  
[http://www.ctg.albany.edu/publications/journals/hicss\\_2012\\_smartcities/hicss\\_2012\\_smartcities.pdf](http://www.ctg.albany.edu/publications/journals/hicss_2012_smartcities/hicss_2012_smartcities.pdf).
23. Chourabi, Hafedh, Nam, Taewoo, Walker, Shawn, Gil-Gracia, Ramon J., Mellouli, Sehl, Nahon, Karine, Prado, Theresa A., and Scholl, Hans Jochen, *Understanding Smart Cities: An Integrative Framework*, [Http://www.ctg.albany.edu/](http://www.ctg.albany.edu/). Hawaii International Conference on System Sciences, 2012b. Page 2290. Web. Last accessed 9 Feb. 2014.  
[http://www.ctg.albany.edu/publications/journals/hicss\\_2012\\_smartcities/hicss\\_2012\\_smartcities.pdf](http://www.ctg.albany.edu/publications/journals/hicss_2012_smartcities/hicss_2012_smartcities.pdf).
24. Chourabi, Hafedh, Nam, Taewoo, Walker, Shawn, Gil-Gracia, Ramon J., Mellouli, Sehl, Nahon, Karine, Prado, Theresa A., and Scholl, Hans Jochen, *Understanding Smart Cities: An Integrative Framework*, Hawaii International Conference on System Sciences, 2012c. Page 2289. Web. Last accessed 9 Feb. 2014.  
[http://www.ctg.albany.edu/publications/journals/hicss\\_2012\\_smartcities/hicss\\_2012\\_smartcities.pdf](http://www.ctg.albany.edu/publications/journals/hicss_2012_smartcities/hicss_2012_smartcities.pdf)

25. Chourabi, Hafedh, Nam, Taewoo, Walker, Shawn, Gil-Gracia, Ramon J., Mellouli, Sehl, Nahon, Karine, Prado, Theresa A., and Scholl, Hans Jochen, *Understanding Smart Cities: An Integrative Framework*, Hawaii International Conference on System Sciences, 2012d. Page 2290. Web. Last accessed 9 Feb. 2014. [http://www.ctg.albany.edu/publications/journals/hicss\\_2012\\_smartcities/hicss\\_2012\\_smartcities.pdf](http://www.ctg.albany.edu/publications/journals/hicss_2012_smartcities/hicss_2012_smartcities.pdf).
26. González, Juan Andrés Alonso, and Rossi, Andrea, *New Trends for Smart Cities*, Competitiveness and Innovation Framework Programme, 2011. Web. Last accessed 9 Feb. 2014. <http://opencities.net/sites/opencities.net/files/content-files/repository/D2.2.21%20New%20trends%20for%20Smart%20Cities.pdf>.
27. Hitachi, *Smart Sustainable City Overview*, Smart Cities: Hitachi, Hitachi, Web. Last accessed 9 Feb. 2014. <http://www.hitachi.com/products/smartcity/vision/concept/overview.html>.
28. IBM, *IBM's Smarter Cities Challenge*, IBM Corporation, July 2013. Web. Last accessed 9 Feb. 2014. [http://smartercitieschallenge.org/scc/executive\\_reports/SCC-Copenhagen-Report.pdf](http://smartercitieschallenge.org/scc/executive_reports/SCC-Copenhagen-Report.pdf).
29. Schneider Electric, *Smart Cities*, Schneider Electric, Web. Last accessed 9 Feb. 2014. [http://www2.schneider-electric.com/sites/corporate/en/solutions/sustainable\\_solutions/smart-cities.page](http://www2.schneider-electric.com/sites/corporate/en/solutions/sustainable_solutions/smart-cities.page).
30. ARUP, *Transforming the 21st Century City via the Creative Use of Technology*, ARUP's IT & Communications Systems Team, 01 Sept. 2011. Web. Last accessed 9 Feb. 2014. [http://www.arup.com/Publications/Smart\\_Cities.aspx](http://www.arup.com/Publications/Smart_Cities.aspx).
31. IBM, *Smarter Cities*, IBM SMARTER PLANET, Web. Last accessed 6 Feb. 2014. [http://www.ibm.com/smarterplanet/us/en/smarter\\_cities/overview/index.html](http://www.ibm.com/smarterplanet/us/en/smarter_cities/overview/index.html).
32. IBM, *Smarter, More Competitive Cities*, IBM SMARTER PLANET, Jan. 2012. Web. Last accessed 6 Feb. 2014. <http://public.dhe.ibm.com/common/ssi/ecm/en/pub03003usen/PUB03003USEN.PDF>.
33. IBM, *India Needs Sustainable Cities*, IBM SMARTER PLANET, Web. Last accessed 6 Feb. 2014. [http://www.ibm.com/smarterplanet/in/en/sustainable\\_cities/ideas/](http://www.ibm.com/smarterplanet/in/en/sustainable_cities/ideas/).
34. Alcatel Lucent, *Understanding the Market Opportunity in the Cities of Tomorrow*, Alcatel Lucent, Feb. 2011. Web. Last accessed 6 Feb. 2014. [http://www2.alcatel-lucent.com/knowledge-center/admin/mci-files-1a2c3f/ma/Smart\\_Cities\\_Market\\_opportunity\\_MarketAnalysis.pdf](http://www2.alcatel-lucent.com/knowledge-center/admin/mci-files-1a2c3f/ma/Smart_Cities_Market_opportunity_MarketAnalysis.pdf).
35. Aoun, Charbel, *The Smart Sustainable City Cornerstone: Urban Efficiency*, Schneider Electric, Web. Last accessed 9 Feb. 2014. [http://www2.schneider-electric.com/documents/support/white-papers/smart-cities/998-1185469\\_smart-city-cornerstone-urban-efficiency.pdf](http://www2.schneider-electric.com/documents/support/white-papers/smart-cities/998-1185469_smart-city-cornerstone-urban-efficiency.pdf).
36. Hitachi, *Smart Cities: Hitachi*, Hitachi, Ltd, Web. Last accessed 9 Feb. 2014. <http://www.hitachi.com/products/smartcity/vision/concept/index.html>.
37. Berton, Bruno, Massat, Patrice, and Collinson, Shawn, *Building and Managing an Intelligent City*, <http://www.accenture.com/>. Accenture Management Consulting, Web. Last accessed 9 Feb. 2014. <http://www.accenture.com/SiteCollectionDocuments/PDF/Accenture-Building-Managing-Intelligent-City.pdf>.
38. Takenaka, Shoji, *Toshiba Smart Community*, Toshiba, 2 Feb. 2012. Web. Last accessed 9 Feb. 2014. <http://www.saudiarabia-jccme.jp/forumpdf/14-2.pdf>.

39. Telefónica, *What Is a Smart Sustainable City?* Telefónica, Web. Last accessed 9 Feb. 2014. <http://smartcity-telefonica.com/?p=373>.
40. Arup, Accenture, Horizon, and University of Nottingham, *Information Marketplaces: The New Economics of Cities*, The Climate Group, Web. Last accessed 9 Feb. 2014. [http://www.theclimategroup.org/\\_assets/files/information\\_marketplaces\\_05\\_12\\_11.pdf](http://www.theclimategroup.org/_assets/files/information_marketplaces_05_12_11.pdf).
41. Huawei, *Brilliant Life Powered by Smart Sustainable City*, Huawei Ltd, Web. Last accessed 9 Feb. 2014. <http://www.huawei.com/en/about-huawei/publications/communicate/hw-079367.htm>
42. Siemens, *Transforming Cities for the Better through Sustainable Technology*, Siemens, Web. Last accessed 9 Feb. 2014. <http://w3.usa.siemens.com/topics/us/en/sustainable-cities/Pages/home.aspx>.
43. Patel, Chandrakanth, *Rebuilding Cities Right*, Hewlett Packard Development Company, L.P., Web. Last accessed 9 Feb. 2014. [http://www.hpl.hp.com/news/2009/jan-mar/patel\\_interview.html](http://www.hpl.hp.com/news/2009/jan-mar/patel_interview.html).
44. Oracle, *Solutions for Smart Cities*, Oracle, Web. Last accessed 9 Feb. 2014. <http://www.oracle.com/us/industries/public-sector/smart-cities.htm>.
45. Dunlop, Harley, *The Role of ITC in Creating a Low-carbon City Region Economy*, GE in Leeds City – UK, 11 Sept. 2012. Web. 15 Feb. 2014. [http://www.basecities.com/content/leeds/docs/pm\\_smart\\_pt1\\_COMPRESSED.pptx](http://www.basecities.com/content/leeds/docs/pm_smart_pt1_COMPRESSED.pptx).
46. Capgemini, *Build Smarter Cities for the Future*, *Www.capgemini.com*. Capgemini, Web. Last accessed 9 Feb. 2014. <http://www.capgemini.com/public-sector/cities>.
47. ABB, *Smart Cities in Italy: An Opportunity in the Spirit of the Renaissance for a New Quality of Life*, ABB, Web. Last accessed 9 Feb. 2014. [http://www02.abb.com/db/db0003/db002698.nsf/0/af0569d84fa29925c1257a71004dc253/\\$file/SmartCitiesReport10Points.pdf](http://www02.abb.com/db/db0003/db002698.nsf/0/af0569d84fa29925c1257a71004dc253/$file/SmartCitiesReport10Points.pdf)
48. Fujitsu, *Making Secure, Prosperous Society a Reality*, Fujitsu, Web. Last accessed 9 Feb. 2014. <http://www.fujitsu.com/global/about/responsibility/feature/2012/smartcity/>
49. Kehoe, Michael, *et al. Smarter Cities Series: A Foundation for Understanding IBM Smarter Cities*, IBM – Red Books, 6 Dec. 2011a. Page 3. Web. Last accessed 9 Feb. 2014. <http://www.redbooks.ibm.com/redpapers/pdfs/redp4733.pdf>.
50. Kehoe, Michael, *et al. Smarter Cities Series: A Foundation for Understanding IBM Smarter Cities*, IBM – Red Books, 6 Dec. 2011b. Page 4. Web. Last accessed 9 Feb. 2014. <http://www.redbooks.ibm.com/redpapers/pdfs/redp4733.pdf>.
51. IBM, *IBM Offers Smarter City Assessment Tool*, 24 June 2009. Web. Last accessed 9 Feb. 2014. <http://www-03.ibm.com/press/us/en/pressrelease/27791.wss>.
52. Fujitsu, *Making Secure, Prosperous Society a Reality*, Fujitsu, Web. Last accessed 9 Feb. 2014. <http://www.fujitsu.com/global/about/responsibility/feature/2012/smartcity/>
53. SAP *Urban Matters: Better Cities, Better Lives*. [Http://global.sap.com](http://global.sap.com/demos/richmedia/videos/sap-urban-matters-better-cities-better-lives-12-ov-us.epx). SAP, Web. Last accessed 12 Feb. 2014. <http://global.sap.com/demos/richmedia/videos/sap-urban-matters-better-cities-better-lives-12-ov-us.epx>.
54. Colclough, Graham, *Transformational Government - Leading Cities Through the Change*, Capgemini – Global Cities, 11 July 2011. Web. Last accessed 12 Feb. 2014. [http://www.smartcities.info/files/22%20-%20Graham%20Colclough%20-%20Creating\\_Smarter\\_Cities\\_2011.pdf](http://www.smartcities.info/files/22%20-%20Graham%20Colclough%20-%20Creating_Smarter_Cities_2011.pdf).

55. Hirst, Paula, *et al. Joint European Support For Sustainable Investment in City Areas*, European Investment Bank, 11 Dec. 2012. Web. Last accessed 12 Feb. 2014. [http://ec.europa.eu/regional\\_policy/thefunds/instruments/doc/jessica/jessica\\_horizontal\\_study\\_smart\\_and\\_sustainable\\_cities\\_en.pdf](http://ec.europa.eu/regional_policy/thefunds/instruments/doc/jessica/jessica_horizontal_study_smart_and_sustainable_cities_en.pdf).
56. Lovehagen, Nina, and Bondesson, Anna, *Evaluating Sustainability of Using ICT Solutions in Smart Cities – Methodology Requirements*, Ericsson, 14 Feb. 2013. Web. Last accessed 12 Feb. 2014. <http://www.ericsson.com/res/docs/2013/lovehagen-bondesson-evaluating-sustainability-of-using-ict-solutions.pdf>.
57. Azkuna, Inaki, *International Study on the Situation of ICT, Innovation and Knowledge in Cities*, City of Bilbao, 2012a. Page 21. Web. Last accessed 12 Feb. 2014. [http://issuu.com/uclgcglu/docs/smartcitiesstudy\\_en](http://issuu.com/uclgcglu/docs/smartcitiesstudy_en).
58. Azkuna, Inaki, *International Study on the Situation of ICT, Innovation and Knowledge in Cities*, City of Bilbao, 2012b. Page 21. Web. Last accessed 12 Feb. 2014. [http://issuu.com/uclgcglu/docs/smartcitiesstudy\\_en](http://issuu.com/uclgcglu/docs/smartcitiesstudy_en).
59. Azkuna, Inaki, *International Study on the Situation of ICT, Innovation and Knowledge in Cities*, City of Bilbao, 2012c. Page 7. Web. Last accessed 12 Feb. 2014. [http://issuu.com/uclgcglu/docs/smartcitiesstudy\\_en](http://issuu.com/uclgcglu/docs/smartcitiesstudy_en).
60. *Smart Cities and Communities*, European Commission, Web. Last accessed 12 Feb. 2014. <http://eu-smartcities.eu/faqs>.
61. Schweiker, Marit, *Aims and Goals of Smart Sustainable City Management - Putting Quality of Citizens' Lives First*, Council of European Municipalities and Regions, 5 Oct. 2010. Web. Last accessed 12 Feb. 2014. [http://ec.europa.eu/regional\\_policy/conferences/od2010/file-upload/2010/docs/39-05A34-Presentation\\_OD\\_Smart\\_Cities\\_CEMR.pdf](http://ec.europa.eu/regional_policy/conferences/od2010/file-upload/2010/docs/39-05A34-Presentation_OD_Smart_Cities_CEMR.pdf).
62. Lee, Jung Hoon, and Hancock, Marguerite Gong, *Toward a Framework for Smart Cities: A Comparison of Seoul, San Francisco & Amsterdam*, Stanford Program on Regions of Innovation and Entrepreneurship, 2012. Web. Last accessed 12 Feb. 2014. [http://iis-db.stanford.edu/evnts/7239/Jung\\_Hoon\\_Lee\\_final.pdf](http://iis-db.stanford.edu/evnts/7239/Jung_Hoon_Lee_final.pdf).
63. *Current Activities For Smart Sustainable Cities*, Japan Ministry of Internal Affairs and Communications (MIC) Smart Town, Contribution No. FG-SSC-0033, ITU Focus Group on Smart Sustainable Cities, Madrid, September 2013. Web. Last accessed 14 Feb 2014. <http://ifa.itu.int/t/fg/ssc/docs/1309-Madrid/in/fg-ssc-0033-japan.doc>
64. *European Innovation Partnership on Smart Cities and Communities*, European Commission, 14 Oct. 2013. Web. Last accessed 12 Feb. 2014. [http://ec.europa.eu/eip/smartcities/files/sip\\_final\\_en.pdf](http://ec.europa.eu/eip/smartcities/files/sip_final_en.pdf).
65. Homeier, Ina, *Smart Sustainable City Wien Initiative*, City of Vienna, May 2013. Web. Last accessed 12 Feb. 2014. <http://www.impacts.org/euroconference/vienna2013/presentations/Vienna%20impacts%20smart%20city.pdf>.
66. Deakin, Mark, *Towards Smart(er) Cities*, European Commission, Web. Last accessed 12 Feb. 2014. [http://www.smartcities.info/files/Towards\\_Smart\(er\)CitiesTC\\_\(2\).pdf](http://www.smartcities.info/files/Towards_Smart(er)CitiesTC_(2).pdf).
67. Horbaty, Robert, *Smart Cities – Intelligente Vernetzung Kommunaler Infrastruktur*, European Energy Award - Energie Schweiz, 19 March 2013. Web. Last accessed 12 Feb. 2014. [http://www.worldresourcesforum.org/files/EM2013/1b\\_Horbaty.pdf](http://www.worldresourcesforum.org/files/EM2013/1b_Horbaty.pdf).

68. Hollands, Robert, *Will the Real Smart Sustainable City Please Stand Up?* Taylor & Francis Online, 26 Nov. 2008. Web. Last accessed 12 Feb. 2014.  
<http://www.tandfonline.com/doi/abs/10.1080/13604810802479126#.Uv-TivmSxUd>
69. *Definitions and Overviews*, Smart Cities Council, Web. Last accessed 12 Feb. 2014.  
<http://smartcitiescouncil.com/smart-cities-information-center/definitions-and-overviews>.
70. Comstock, Maggie, *What Is a Smart Sustainable City and How Can a City Boost Its IQ?* World Bank Blogs – Sustainable Cities, 02 April 2012. Web. Last accessed 12 Feb. 2014.  
<http://blogs.worldbank.org/sustainablecities/what-is-a-smart-city-and-how-can-a-city-boost-its-iq>.
71. "Smart Sustainable City, Business Dictionary, Web. Last accessed 13 Feb. 2014.  
<http://www.businessdictionary.com/definition/smart-city.html>.
72. Ott, Marc, *Tools for Sustainable Cities*, HBR Blog Network, 20 April 2011. Web. Last accessed 12 Feb. 2014. <http://blogs.hbr.org/2011/04/the-sustainable-places-analyti/>.
73. *White Paper on Smart Sustainable Cities*, Fiberhome Technologies Group, Contribution No. FG-SSC-0005, ITU Focus Group on Smart Sustainable Cities, Turin, May 2013. Web. Last accessed 14 Feb 2014. <http://ifa.itu.int/t/fg/ssc/docs/1305-Turin/in/fg-ssc-0005-fiberhome%20technologies%20group.zip>
74. *Smart Sustainable Cities – Food For Thought*, Sekhar Kondepudi, National University of Singapore, Contribution No. FG-SSC-0013, ITU Focus Group on Smart Sustainable Cities, Turin, May 2013. Web. Last accessed 14 Feb 2014. <http://ifa.itu.int/t/fg/ssc/docs/1305-Turin/in/fg-ssc-0013-singapore%20university.zip>
75. *Smart Sustainable Cities & Smart Statistics*, Government of Italy, Contribution No. FG-SSC-0014, ITU Focus Group on Smart Sustainable Cities, Turin, May 2013. Web. Last accessed 14 Feb 2014. <http://ifa.itu.int/t/fg/ssc/docs/1305-Turin/in/fg-ssc-0014-Italy.zip>
76. *Requirements and opportunities in developing a common, cost-effective, reliable and secure ICT infrastructure by exploiting and fostering synergies among different areas encompassed in the concept of Smart Sustainable Cities*, University of Genoa, Contribution No. FG-SSC-0020, ITU Focus Group on Smart Sustainable Cities, Turin, May 2013. Web. Last accessed 14 Feb 2014.  
<http://ifa.itu.int/t/fg/ssc/docs/1305-Turin/in/fg-ssc-0020-genoa%20university.zip>
77. Hwang, Jong Sung, and Choe, Young Han, *Smart Cities Seoul: A Case Study*, International Telecommunication Union, Feb. 2013. Web. Last accessed 12 Feb. 2014.  
[http://www.itu.int/dms\\_pub/itu-t/oth/23/01/T23010000190001PDFE.pdf](http://www.itu.int/dms_pub/itu-t/oth/23/01/T23010000190001PDFE.pdf)
78. Cohen, Boyd, *The Top 10 Smart Cities On The Planet*, Fast Company, 11 Jan. 2011. Web. Last accessed 12 Feb. 2014.  
<http://www.fastcoexist.com/1679127/the-top-10-smart-cities-on-the-planet>.
79. *Manesar to Home Eco-city Project*, Business Standard, 22 April 2011. Web. Last accessed 12 Feb. 2014. [http://www.business-standard.com/article/economy-policy/manesar-to-home-eco-city-project-111042200074\\_1.html](http://www.business-standard.com/article/economy-policy/manesar-to-home-eco-city-project-111042200074_1.html).
80. Washburn, Doug, and Sindhu, Usman, *Helping CIOs Understand "Smart Sustainable City" Initiatives*, FORRESTER, Last accessed 11 Feb. 2010. Web. Last Accessed 12 Feb. 2014.  
[http://public.dhe.ibm.com/partnerworld/pub/smb/smarterplanet/forr\\_help\\_cios\\_und\\_smart\\_city\\_initiatives.pdf](http://public.dhe.ibm.com/partnerworld/pub/smb/smarterplanet/forr_help_cios_und_smart_city_initiatives.pdf).



81. Woods, Eric, and Wheelock, Clint, *Smart Cities*, Navigant Research, 2013. Web. Last accessed 12 Feb. 2014. <http://www.navigantresearch.com/wp-assets/uploads/2013/01/SCIT-13-Executive-Summary.pdf>.
82. Hodkinson, Steve, *Is Your City Smart Enough*, OVUM Consulting, March 2011. Web. Last accessed 12 Feb. 2014. [http://www.cisco.com/web/strategy/docs/Is\\_your\\_city\\_smart\\_enough-Ovum\\_Analyst\\_Insights.pdf](http://www.cisco.com/web/strategy/docs/Is_your_city_smart_enough-Ovum_Analyst_Insights.pdf).
83. Belissent, Jennifer, *Getting Clever About Smart Cities: New Opportunities Require New Business Models*, FORRESTER, 2 Nov. 2010. Web. Last accessed 13 Feb. 2014. <http://www.forrester.com/Getting%2BClever%2BAbout%2BSmart%2BCities%2BNew%2BOpportunities%2BRequire%2BNew%2BBusiness%2BModels/fulltext/-/E-RES56701?objectid=RES56701>
84. Maio, Andrea Di, *Technology Is Almost Irrelevant for Smart Cities To Succeed*, Gartner, 10 Aug. 2012. Web. Last accessed 13 Feb. 2014. [http://blogs.gartner.com/andrea\\_dimai/2012/08/10/technology-is-almost-irrelevant-for-smart-cities-to-succeed/](http://blogs.gartner.com/andrea_dimai/2012/08/10/technology-is-almost-irrelevant-for-smart-cities-to-succeed/).
85. *Smart Cities Strategies*, IDC, Web. Last accessed 13 Feb. 2014. [http://www.idc.com/getdoc.jsp?containerId=IDC\\_P23432](http://www.idc.com/getdoc.jsp?containerId=IDC_P23432).
86. *Innovative Future of Russia's Cities*, Center for Smart Sustainable City Innovation – Ernst & Young, Web. Last accessed 13 Feb. 2014. <http://www.ey.com/RU/en/Services/Specialty-Services/Smart-City-Innovation-Center>.
87. Craren, Tom, Dougher, Brendan, and Wylde, Kathryn, *Cities of Opportunity*, PwC, 2012a. Page 4. Web. 15 Feb. 2014. <http://www.pfnyc.org/reports/2012-Cities-of-Opportunity.pdf>.
88. Craren, Tom, Dougher, Brendan, and Wylde, Kathryn, *Cities of Opportunity*, PwC, 2012b. Page 3. Web. 15 Feb. 2014. <http://www.pfnyc.org/reports/2012-Cities-of-Opportunity.pdf>.
89. Woods, Eric, and Gartner, John, *Smart Sustainable City Suppliers*, Navigant Research, 2013. Web. Last accessed 13 Feb. 2014. <http://www.navigantresearch.com/wp-assets/uploads/2013/07/LB-SCITS-13-Executive-Summary.pdf>.
90. Haji, Sheeraz, *State of Cleantech Innovation*, Deloitte Services LP, 20 Sept. 2013. Web. Last accessed 13 Feb. 2014. [http://www.deloitte.com/assets/Dcom-UnitedStates/Local%20Assets/Documents/Energy\\_us\\_er/us\\_er\\_2013AESeminar\\_NewTechnologies\\_Sep2013.pdf](http://www.deloitte.com/assets/Dcom-UnitedStates/Local%20Assets/Documents/Energy_us_er/us_er_2013AESeminar_NewTechnologies_Sep2013.pdf).
91. Bouton, Shannon, Linday, Molly, and Woetzel, Jonathan, *New Models for Sustainable Growth in Emerging-market Cities*, McKinsey & Company, June 2012. Web. Last accessed 13 Feb. 2014. [http://mckinseyonsociety.com/downloads/reports/Sustainability/SRP\\_07\\_Cities.pdf/](http://mckinseyonsociety.com/downloads/reports/Sustainability/SRP_07_Cities.pdf/).
92. Toppeta, Donato, *The Smart Sustainable City Vision: How Innovation and ICT Can Build Smart, "liveable", Sustainable Cities*, Think Innovation, Oct. 2010. Web. Last accessed 13 Feb. 2014. <http://www.thinkinnovation.org/en/portfol/the-smart-city-vision-how-innovation-and-ict-can-build-smart-liveable-sustainable-cities-2-2/>.
93. Jaokar, Ajit, *Big Data for Smart Cities*, Smart Cities Industry Summit, London, Sept. 2012, Web. Last accessed Feb. 14 2014. <http://www.opengardensblog.futuretext.com/wp-content/uploads/2012/09/informa-smart-cities-ajit-jaokar.pdf>
94. *The Apps for Smart Cities Manifesto*, World Smart Capital, 2012. Web. Last accessed 13 Feb. 2014. <http://www.appsforsmartcities.com/?q=manifesto>



95. Definition of Smart Cities – China Communications Standards Association (CCSA), Smart Sustainable City: terminologies and definitions, 2013, [http://www.ccsa.org.cn/workstation/project\\_disp.php?auto\\_id=4336](http://www.ccsa.org.cn/workstation/project_disp.php?auto_id=4336) (in Chinese)
96. European Innovation Partnership on Smart Cities and Communities – Strategic Implementation Plan, 2013. Web. Last accessed 02 March 2014. [http://ec.europa.eu/eip/smartcities/files/sip\\_final\\_en.pdf](http://ec.europa.eu/eip/smartcities/files/sip_final_en.pdf)
97. Vienna University of Technology, University of Ljubljana, Delft University of Technology. Smart Cities: Ranking of European Medium-Sized Cities. October 2007.
98. Rapoport, E., *Utopian Visions and Real Estate Dreams: The Eco-city Past Present and Future*, Geography Compass, Volume 8, Issue 2, pages 137–149, February 2014
99. Alusi, A., Eccles, R. G., Edmondson, A. C., Zuzul, T., *Sustainable Cities: Oxymoron or the Shape of the Future*, Working Paper 11-062 Havard Business School. 2011.
100. Njikamp, Lombardi, P., Giordano, S., Caraglui, A., Del Bo, C., Deakin, M., *An advanced triple helix network model for smart city performance*, . No 45, [Serie Research Memoranda from VU University Amsterdam, Faculty of Economics, 2011](http://EconPapers.repec.org/RePEc:vua:wpaper:2011-45) . <http://EconPapers.repec.org/RePEc:vua:wpaper:2011-45>
101. Monedero, D. R., Bartoli, A., Hernandez-Saerrano, J., Forne, J., Soriano, M., *Reconciling privacy and efficient utility management in smart cities*, Transactions on emerging telecommunication technologies. September 2013.
102. Balloon, Pieter, Glidden, J., Kranas, P., Menychtas, A., Ruston, S., Van der Graaf, S., *Is there a need for cloud platform for European Smart Cities?* eChallenges e-2011 Conference Proceedings, IIMC International Information Management Corporation, 2011, ISBN: 978-1-905824-27-4.
103. Batty, M., Axhausen, K. W., Giannotti, F., Pozdnoukhov, A., Bazzani, A., Wachowicz, M., Ouzounis, G., Portugali, Y., *Smart cities of the future*, The European Physical Journal, pp. 418-518. December 2012.
104. Antrobus, D., *Smart green cities: from modernization to resilience*, Urban Research and Practice, Vol. 4, July 2011.
105. Allwinkle, S., Cruickshank, P., *Creating Smarter Cities: An Overview*, Journal of Urban Technology, 2011.
106. Benouaret, K., Ramalingam, R. V., Charoy, F., Crowd, S. C., *Building Smart Cities with Large Scale Citizen Participation*, IEEE Computer Society. December 2013.
107. Papa, R., *Smart City: Researches, Projects and Good Practices for the City*, Journal of Land Use, Mobility and Environment. April 2013.
108. Lee, J. H., Hancock, M. G., Hu, M., *Towards an effective framework for building smart cities: Lessons from Seoul and San Francisco*, Technological Forecasting and Social Change. November 2012.
109. Paroutis, S., Bennett, Heracleous, L., *A strategic view on smart city technology: The case of IBM Smarter Cities during a recession*, Technological Forecasting and Social Change: An International Journal. November 2012.

110. Llacuna, M. L. M., Llinas, J. C., Frigola, J. M., *Lessons in urban monitoring taken from sustainable and livable cities to better address Smart City initiatives*, Technological Forecasting and Social Change: An International Journal. January 2014.
111. Kramers, A., Hojer, M., Lovehagen, N., Wangel, J., *Smart Sustainable Cities-Exploring ICT Solutions for reduced energy use in cities*, Environmental Modelling and Software, Issue 56. January 2014. pp. 52-62.
112. Neirotti, P., De Marco, A., Cagliano, A. C., Mangano, G., Scorrano, F., *Current Trends in Smart City initiatives: Some stylized facts*, Cities: The International Journal of Urban Policy and Planning. January 2014.
113. Naphade, M., Guruduth, B., Harrison, C., Jurij, P., Morris, R., *Smarter Cities and their innovation Challenges*, IBM. 2011.
114. Asimakopoulou, E., Bessis, N., *Buildings and Crowds: Forming Smart Cities for more effective disaster management*, Fifth International Conference on Innovative Mobile and Internet Services in the Ubiquitous Computing. 2011.
115. Hall, R. E., *The vision of a smart city*, In Proceedings of the 2nd International Life Extension Technology Workshop, Paris, France. 2000.
116. Nfuka, E. N., Rusu, L., *Critical success factors for effective IT governance in the public sector organization in a developing: The case of Tanzania*, In proceeding of the 18th European Conference on Information Systems (ECIS), Pretoria, South Africa. June 7-9 2010.

## Annex 3 – Glossary of Terms

---

ANSI	American National Standards Institute
BSI	British Standards Institution
EMF	Electro-Magnetic Field
FG-SSC	Focus Group on Smart Sustainable Cities
IEEE	Institute of Electrical and Electronics Engineers
IEC	International Electrotechnical Commission
ICT	Information and Communication Technology
ICTs	Information and Communication Technologies
ISO	International Organization for Standardization
IT	Information Technology
IUCN	International Union for Conservation of Nature
KPIs	Key Performance Indicators
MRT	Mass Rapid Transit
NGO	Non-Governmental Organization
QoL	Quality of Life
RFID	Radio Frequency Identification Device
SSC	Smart Sustainable Cities
SDO	Standards Development Organization
SG	Study Group
UNEP	United Nations Environment Programme
WG	Working Group
WHO	World Health Organization
WWF	World Wide Fund for Nature

issc

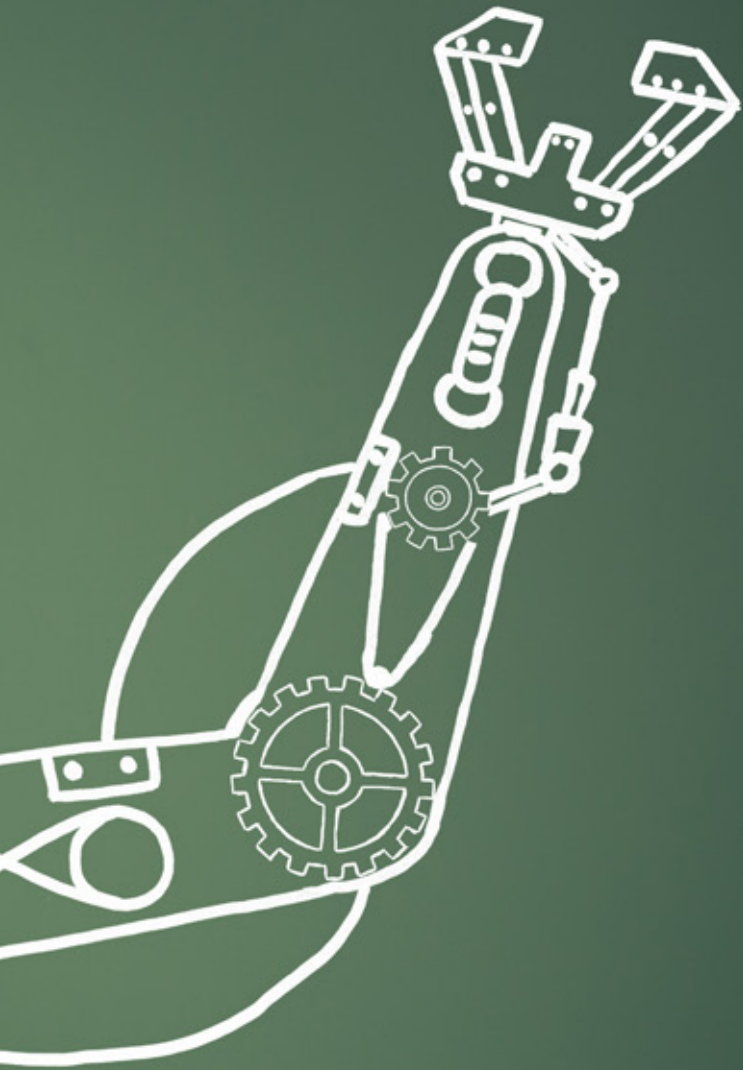


CREATIVE  
THINKING









# 2.3

## Smart sustainable cities: a guide for city leaders

Technical Report



## Acknowledgement

This Technical Report was researched and written by Silvia Guzmán Araña (Spain) and Mythili Menon (University of Geneva), as a contribution to ITU-T Focus Group on Smart Sustainable Cities (FG-SSC).

Special thanks to Angelica Ospina (University of Manchester), Juan Manuel Sabio Morchio (University of KwaZulu-Natal, South Africa), Mike Wood (Telstra), Paolo Gemma (Huawei), Sang Ziqin (Fiber Home Technologies), Guilherme Canela (UNESCO) for their helpful review and contribution.

Additional information and materials relating to this report can be found at: [www.itu.int/itu-t/climatechange](http://www.itu.int/itu-t/climatechange). If you would like to provide any additional information, please contact Cristina Bueti at [tsb5@itu.int](mailto:tsb5@itu.int).

## Table of Contents

	<b>Page</b>
<b>1</b> Introduction .....	<b>128</b>
<b>2</b> Smart sustainable cities: the urban future we want! .....	<b>128</b>
<b>3</b> Starting your SSC journey .....	<b>129</b>
<b>4</b> Cities are our best future!.....	<b>132</b>
<b>Bibliography</b> .....	<b>133</b>

## 1 Introduction

---

Modern cities have experienced unprecedented socio-economic growth and environmental crises since the latter half of the 20th century and the beginning of the 21st century. In 2014, there were 28 mega cities, home to 453 million people.<sup>1</sup> With 54% of the world's population living in urban areas, cities are confronted with contemporary problems, ranging from rapid urbanization, rising pollution levels and an ever increasing rural to urban migration, all of which have exerted pressure on an ageing city infrastructure.

*“It is a truth universally acknowledged that a (smart) city in possession of a good ICT infrastructure must also be sustainable”*

Projections indicate that the percentage of the global population living in cities is expected to rise to 66% by 2050.<sup>2</sup> Globally, cities also account for 75-80% of a country's GDP and are considered the main engines of global economic growth.<sup>3</sup> On the flip side, cities also produce 50% of the global waste<sup>4</sup> along with 60% of the global greenhouse gas (GHG) emissions.<sup>5</sup>

As a result, there is increasing pressure on existing natural resources such as water, land and fossil fuels.<sup>6</sup> Additionally, there are growing concerns regarding existing transportation infrastructure, provision of adequate healthcare, access to education and overall safety for the growing population of urban residents.<sup>7</sup>

## 2 Smart sustainable cities: the urban future we want!

---

In light of the above facts, urban planners are faced with daunting questions as to whether to promote cities as drivers of economic growth or pay heed to issues such as increasing population, resource overuse and dependence in cities. Understanding this dilemma, ITU's Focus Group on Smart Sustainable Cities (FG-SSC) set the path for cities to become smart and sustainable. Smart Sustainable Cities (SSC) is a concept developed by the FG-SSC which intends to leverage the potential of Information and Communication Technology (ICT) in urban governance systems to create cities which are not only economically and socially advanced but are also designed to achieve environmental sustainability.

---

<sup>1</sup> World Habitat Day: Voice from Slums. UN-Habitat

<sup>2</sup> World Habitat Day: Voice from Slums. UN-Habitat

<sup>3</sup> How can Cities decouple economic growth from resource use and its environmental impacts and find a balance between social, environmental and economic goals?. United Nations Environment Programme

<sup>4</sup> Cities and Buildings. United Nations Environment Programme

<sup>5</sup> Cities and Climate Change Mitigation: UN-Habitat

<sup>6</sup> Smarter Cities and Their Innovation Challenges

<sup>7</sup> Evolution Roadmaps for Smart Cities: Determining Viable Paths

*"A smart sustainable city is an innovative city that uses information and communication technologies (ICTs) and other means to improve quality of life, efficiency of urban operation and services, and competitiveness, while ensuring that it meets the needs of present and future generations with respect to economic, social, environmental as well as cultural aspects".*

Source: ITU-T Study Group 5 and UNECE (2015)

This document is intended for city decision makers and strategists, whose decisions have a significant impact on the way their city functions and its future development trajectory. Accordingly, this high level policy document helps identify practical steps based on which urban decision makers can envisage and build their very own Smart Sustainable City!

### 3 Starting your SSC journey

---

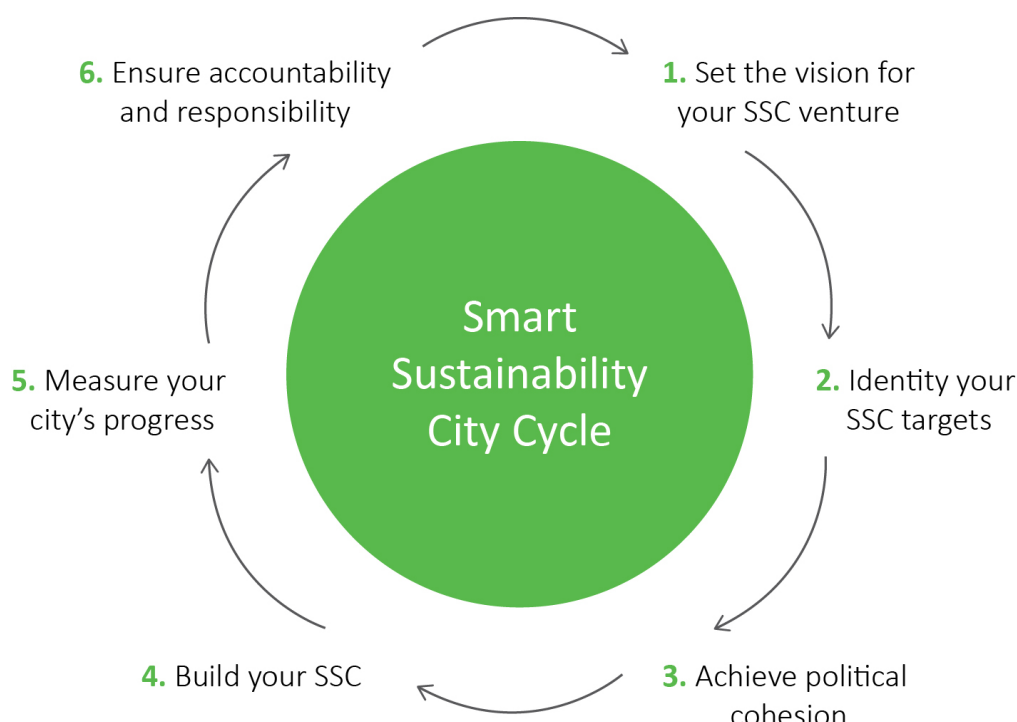
For cities wishing to go the SSC way, each city has to start from a different baseline for their transition to a Smart Sustainable City. However, it is important to understand that SSC means embracing a journey and cannot be considered the final destination.

Through its research work on SSC, FG-SSC intended to assist city decision makers (including municipal and government representatives) by re-defining the way in which the city's infrastructure is built, services are offered, citizens are engaged and systems linked, with the aim of transforming cities into more sustainable, smart, resilient and robust living environments.

Realizing that the establishment of SSC is a long term process and cannot be achieved overnight, it is essential that a series of generic steps are defined that would not only allow for comparability but would also promote sustainable development along with each city being able to quantify improvements as time passes.

In keeping with this thought, the FG-SSC has developed some basic steps for SSC transformation. Each of the steps described in this document are required when making transition to a Smart Sustainable City. These steps can help formulate an action strategy oriented to: (i) consensus building among varied stakeholders, (ii) governance mechanisms, (iii) citizen engagement, (iv) ICT infrastructure, (iv) monitoring mechanisms and (v) learning among SSC stakeholders.

Figure 1 gives an overview of the steps to becoming a Smart Sustainable City.



**Figure 1 – SSC 6-step Transition cycle**  
(adapted from on ICLEI’s ‘Sustainability Cycle’)

### Step (1) Set the vision for your SSC venture

Local Governments should increasingly take on a more central role in such development initiatives. They should assist in identifying a specific SSC vision and assessing the city’s existing situation in order to establish the relevance and feasibility of becoming a Smart Sustainable City. This step includes the following aspects:

- a) Identifying a SSC vision that is in line with the city’s identity, political priorities and long-term development strategy;
- b) Gathering relevant data on the status of ICT infrastructure and its usage at the city-level, including the status of the city in regards to the widely used FG-SSC Technical Specifications ad Reports;
- c) Identifying the SSC stakeholders;
- d) Identifying the existing governance and organisational mechanisms that would allow an efficient and effective management of SSC solutions;
- e) Identifying mechanisms for multi-stakeholder involvement, citizen engagement, communication and information sharing throughout the SSC process.

This step can be facilitated through a basic SSC SWOT analysis (Strengths, Weaknesses, Opportunities and Threats for each city). This will assist in framing a city specific strategy and goals.

### Step (2) Identify your SSC targets

Local governments should work in close collaboration with the various SSC stakeholders to design the overall master plan for the SSC’s implementation. This should include broad agreement on objectives, priorities, initiatives and actions needed in the short, medium and long term.

Consideration should be accorded to setting measurable SSC targets and timeframes for their achievement. This step involves, among others, the identification of SSC targets in regards to:

- a) Developing SSC infrastructure and integrated platform for example using Internet of Things (IoT);
- b) Identifying and developing SSC services;
- c) Defining SSC Key Performance Indicators (KPIs);
- d) Educating the stakeholders on the advantages of SSC.

### Step (3) Achieve political commitment

Engagement with political leadership is imperative. Local governments should obtain the necessary political approval and backing to ensure that the SSC strategic programme is pursued. This includes the adoption of the SSC programme/targets through consensus. This will provide the basis for an agreed document that has widespread support, and will serve as a reference for the strategic planning by the local authority.

### Step (4) Build your SSC

Using the political backing gained in Step 3 and support from other SSC stakeholders, local governments should lead the way to actually initiating the establishment of their smart sustainable city. For this step, the existing traditional infrastructure may be significantly improved on by integrating the required ICT applications for the upgrade to SSC. The stakeholders may also choose to build a new infrastructure from scratch.

For either of the aforementioned scenarios, the following features are pertinent:

- a) Making of a feasible master plan for your SSC journey;
- b) Conforming to appropriate construction models (e.g. Public Private Partnerships in various SSC programmes);
- c) Ensuring long term services via good operation and maintenance after the infrastructure is in place.

### Step (5) Measure your city progress

The fifth step consists of monitoring and evaluating a work programme required to achieve the targets. This stage involves close coordination and collaboration among SSC stakeholders, as well as an assessment on the basis of relevant Key Performance Indicators (KPIs). The FG-SSC has developed a useful set of KPIs for SSC, which can be utilized for this specific step. These KPIs form an excellent baseline for city decision makers, as they map their city's progress of their overall SSC journey.

### Step (6) Ensure Accountability and Responsibility

The last step is focused on evaluating, reporting and learning from the SSC process and related experiences. This involves an assessment of the implementation of the work programme, and an analysis of reflections about strengths and shortcomings. Such an evaluation contributes to informing the decision making process of the local council, as well as to inform the preparation of future baseline reviews to deepen SSC master plans, among others.

Better decisions are reached if they emerge out of a process of knowledge sharing and dialogue between stakeholders. The reflective process of evaluation will feed into a process of continuous learning, which in turn will influence and inform the development of the future vision and strategy for SSC.



Cities must be capable of applying lessons learned and instituting best practices concerning SSC. Consequently, cities must be accountable for continuous improvement to strengthen the effectiveness of future SSC strategies. For this city leaders must be flexible and able to adapt to the dynamic, evolving and complex nature of SSC and be able to continuously update the vision as required.

## 4 *Cities are our best future!*

---

While sustainability challenges of cities are significant, urban areas also hold the key to achieving many global sustainability goals. Cities are home to the majority of humanity, and sustainable development cannot be achieved without significantly transforming the way we build and manage our urban spaces.

The infusion of ICT into key processes is pertinent to achieving sustainability. ICTs can assist with the establishment of SSCs through innovation, redesign of existing processes. This can include new applications, technologies and systems for smart energy, smart transportation, smart buildings, smart water management and smart Government.

*“To be.... or not to be a Smart Sustainable City. That is no longer the question”.*

As ICTs provide an integrated strategic approach to sustainability in SSC, they are key enablers of urban development, making ICT integration also vital to the achievement of the post-2015 Sustainable Development Goals (SDGs).

Cities do not have the option to continue functioning as they have done in the past. Hence city decision makers have to see the writing on the wall, and decide on a maintainable urban process, which promotes economic progress as well as environmental protection. Here, the SSC vision not only provides the benefit for sustained economic growth but also ensures a high quality of life for the citizens along with environmental sustainability.

## Bibliography

- Anthopoulos, Leonidas, Fitsilis, Panos. *Evolution Roadmaps for Smart Cities: Determining Viable Paths*. Proceedings of the European Conference on e-governance.
- Cities and Buildings. United Nations Environment Programme (UNEP).
- Cities and Climate Change Mitigation. UN-Habitat - <http://unhabitat.org/climate-change/>.
- How can cities decouple economic growth from resource use and its environmental impacts and find a balance between social, environmental and economic goals? United Nations Environment Programme (UNEP). 2013.
- Naphde. M, Banavar. G, Harrison. C, Paraszczak. J., *Smarter Cities and Their Innovation Challenges*. 2011.
- Sustainability Cycle, ICLEI, 2014,  
<http://www.sustainablecities.eu/pathways/integratedmanagement/sustainability-cycle/>
- World Urbanization Prospects: Revision 2014, United Nations.
- World Habitat Day: Voice from Slums. UN-Habitat. 2012.
- Focus Group on Smart Sustainable Cities (FG-SSC), ITU, 2015





# 2.4

**Master plan  
for smart  
sustainable cities**

**Technical Report**

## Acknowledgements

This Technical Report was researched and principally authored by Silvia Guzmán Araña, FG-SSC Chairman. The author would like to first thank ITU for providing such an exciting opportunity to work and research under the ITU-T Focus Group on Smart Sustainable Cities (FG-SSC).

Special thanks goes also to Ziqin Sang (Fiberhome Technologies), Mythili Menon (University of Geneva), Daniela Torres (Spain), Ramy Ahmed Fathy (NTRA, Egypt), Lei Gu (China Telecom), Michael Mulquin (IS Communications Ltd), Sabrina Coccia (Smart Metropolis), John Devaney (BSI) and Angelica Ospina (University of Manchester).

Additional information and materials relating to this report can be found at: [www.itu.int/itu-t/climatechange](http://www.itu.int/itu-t/climatechange). If you would like to provide any additional information, please contact Cristina Bueti at [tsbsg5@itu.int](mailto:tsbsg5@itu.int).

## Table of Contents

	<b>Page</b>
<b>1 Introduction .....</b>	<b>141</b>
<b>2 SSC definition .....</b>	<b>143</b>
<b>3 Building a master plan: towards an integrated management in SSC .....</b>	<b>145</b>
3.1 Phase 1: Setting the basis for a Smart Sustainable City .....	146
3.2 Phase 2: Strategic Planning .....	149
3.3 Phase 3: Action Plan .....	150
3.4 Phase 4: Management Plan .....	163
<b>4 Conclusions and key considerations .....</b>	<b>164</b>
<b>References .....</b>	<b>166</b>





## Master plan for smart sustainable cities

### Executive Summary

This Technical Report has been developed within the Focus Group on Smart Sustainable Cities (FG-SSC) of the International Telecommunication Union (ITU). It aims to foster the design and implementation of an integrated management scheme on Smart Sustainable Cities (SSC), proposing feasible phases to develop a City Master Plan that can be followed by any municipality interested in utilizing Information and Communication Technologies (ICTs) as enablers of urban transformation.

Defined as "*an innovative city that uses ICTs and other means to improve quality of life, efficiency of urban operation and services, and competitiveness, while ensuring that it meets the needs of present and future generations with respect to economic, social, environmental as well as cultural aspects*", the notion of SSC is becoming crucial to overcome the challenges and benefit from the opportunities that characterize complex urban environments.

Amidst the challenges posed by rapid urbanization and multiple/concurrent vulnerability dimensions (e.g., economic, social, political and environmental), decision-makers are facing the pressing need to re-think and re-define the way in which infrastructure is built, services are offered, citizens are engaged, and systems linked, with the aim of transforming cities into more sustainable and robust living environments.

Based on the work conducted by FG-SSC members and contributing organizations, this technical report suggests that SSC Master Plan is a dynamic process that involves four inter-connected phases.

The starting point of the proposed Master Plan is the recognition that, while technology is an essential component of strategies to develop and implement SSC, cities are about *people*. Therefore, any strategy aimed at making urban systems smarter and more sustainable, should be focused on ultimately improving the quality of life of the city's inhabitants through novel, more efficient, and increasingly inclusive ICT-enabled approaches.

In order to follow the suggested phases of the Master Plan, it is very important to start by defining a baseline of the actual city status; "Phase 1: Setting the Basis for a smart sustainable city". This baseline will provide municipalities with valuable information about the strengths and weaknesses of the city. This information allows the design of specific projects, aimed at improving the weaker aspects of the city.

The "Phase 2: Strategic Planning" for a SSC, including the governance, leadership and citizen engagement is required to move SSC's vision forward in short, medium and long term. The early identification of inclusive stakeholder and citizen engagement mechanisms (to be implemented throughout the process) is seen as a key component of the SSC Master Plan.

It is also extremely important to reach a consensus among local authorities and other stakeholders during the definition of the priorities and objectives of a smart sustainable city. Becoming a smart sustainable city is a long-term path that can be slowed down and/or hindered by political disagreements. Hence, SSC cannot be used as a "political tool" and instead should be fostered as a long-term strategy to improve the quality of life in the city.

The "Phase 3: Action Plan", has to do with the planning and development of strategic lines of action of the city, the identification of SSC initiatives to be developed, and the establishment of the ICT technology plan.

Focus on identifying the ICT infrastructure that can be used to increase the smartness and sustainability of the city, as well as the strategic planning is required for the deployment (and integration) of ICT infrastructure at the national level. This includes mechanisms for municipalities to incentivize supply and demand of SSC infrastructure, as well as to access the necessary funding.

Additionally, this phase consists of the identification and promotion of SSC services that should be part of a city's integrated planning, in order to address complex urban challenges. Key SSC services include smart water management, smart energy management, smart transportation, smart waste management, smart healthcare, smart education, physical safety and security, smart buildings, as well as city services for climate change mitigation and adaptation.

The activities conducted as part of this phase, will provide the basis of a smart sustainable city Security System, including the minimum requirements for its implementation, and the technologies that are needed to achieve it.

The "Phase 4: Management Plan" includes the definition of the city governance and the setting of the monitoring dashboard to evaluate city performance in the future, in order to assess the improvement achieved. This activity will be carried in parallel and in alignment with the KPIs assessment process.

The development and implementation of 'Key Performance Indicators' (KPIs) is also essential to provide a basic set of criteria to evaluate existing cities and to measure the results of different projects, with the aim of increasing smartness and sustainability. The use of KPIs is critical to measure and to quantify efficiency improvements in city services through the implementation of SSC services.

Each of the stages and technical requirements described as part of this Master Plan are based on a series of detailed technical reports and specifications that have been produced as part of the FG-SSC's mandate. These reports and specifications are freely available for consultation<sup>1</sup> for interested parties.

The analysis also identifies some of the key factors that can influence the effectiveness of the Master Plan implementation. These key factors need to be taken into account by municipal stakeholders and city decision-makers for building their SSC.

---

<sup>1</sup> Please find the FG-SSC Technical Reports and Specifications at: <http://www.itu.int/en/ITU-T/focusgroups/ssc/Pages/default.aspx>

# 1 Introduction

---

Within an increasingly inter-connected world, rapid urbanization constitutes one of the most challenging facets of the 21<sup>st</sup> century. 54% of the world's population resides in urban areas, a percentage that is expected to reach 66% by 2050<sup>2</sup>. The growth of the world's urban population is evidencing the need to re-think traditional approaches to sustainable development and urban planning, in both developed and developing countries. During the period between 1950-2010, small cities have grown in population (1.3 billion) much more than medium cities (632 million) or large cities (570 million)<sup>3</sup>. According to the United Nations Population Fund (UNFPA), in 2007, for the first time in the history, people living in cities were more than those in rural areas<sup>4</sup>.

Due to migration flows, the natural population growth and certain policies, among other factors, urban areas are becoming more congested. Rapid urbanization is adding pressure to the existing resource base, while increasing the demand for energy, water, sanitation, and public services such as education and health care. In parallel to the rising demand for services, cities are developing into vast consumers of energy and major producers of greenhouse gas (GHG) emissions, and have been estimated to represent three quarters of the global energy consumption and 80% of CO<sub>2</sub> emissions worldwide<sup>5</sup>.

In order to meet the growing needs and the opportunities associated with an increasing urban population, cities require innovative approaches to achieve sustainable development. This involves an improvement in the efficiency of all aspects of a city's operation (e.g., public services, construction, transportation), which are crucial to ensure more inclusive development pathways, and a higher quality of life (QoL) for its inhabitants.

Smart Sustainable Cities (SSC) are key enablers for the achievement of these goals. Despite the recent emergence of SSC initiatives around the globe<sup>6</sup>, efforts to realize an integrated vision based on the notions and implications of 'smartness' and sustainability, including the standardization efforts needed to assess their efficiency, are still in the early stages.

As the momentum of SSC continues to grow, there is an increasing need to better understand and foster the use of new technologies, particularly of rapidly diffusing Information and Communication Technologies (ICTs). Addressing this need is at the core of the Focus Group on Smart Sustainable Cities' (FG-SSC) mandate.

---

<sup>2</sup> UNDESA (2014), 'World Urbanization Prospects: The 2014 Revision, Highlights', United Nations, Department of Economic and Social Affairs, Population Division.  
<http://esa.un.org/unpd/wup/Highlights/WUP2014-Highlights.pdf>

<sup>3</sup> UNDESA (2013), 'World Economic and Social Survey 2013: Sustainable Development Challenges Overview', United Nations Department of Economic and Social Affairs (UNDESA), [http://www.un.org/en/development/desa/policy/wess/wess\\_current/WESS%20Overview%202013%20E.pdf](http://www.un.org/en/development/desa/policy/wess/wess_current/WESS%20Overview%202013%20E.pdf)

<sup>4</sup> UNFPA (2007) 'State of the World Population 2007: Unleashing the Potential of Urban Growth', United Nations Population Fund (UNFPA), <http://www.unfpa.org/swp/2007/english/introduction.html>

<sup>5</sup> Provoost, R. (2013), 'Smart Cities: Innovation in Energy will Drive Sustainable Cities', The Guardian Professional, 13 November, <http://www.theguardian.com/sustainable-business/smart-cities-innovation-energy-sustainable>

<sup>6</sup> See for example the Partnership for Smart and Sustainable Cities, <http://www.urbanknowledge.org/smartsustainablecities.html>

The efforts conducted by this group have been rooted on the recognition of the city as a complex system that is continuously evolving, and one that is formed by a wide variety of stakeholders that need to be involved in any strategy leading to a more sustainable future. In line with this understanding, efforts to develop 'smart' technological innovations, and to integrate physical infrastructures, are not enough. The role of ICTs within SSC strategies needs to be articulated with broader, more holistic visions of the city, in synchrony with its identity and urban development goals, supported by appropriate governance structures, and being responsive to the needs of the citizens, who are at the core of the city's functioning.

Building on this basis, the report suggests a stage-based, action-oriented process or 'Master Plan Phases' to develop an integrated management scheme for SSC, to help inform the work of city decision makers, as they tackle the challenge of transforming their cities into Smart Sustainable Cities.

### Scope

This document seeks to provide municipalities and interested stakeholders with a general overview of the stages and technical specifications that need to be considered to effectively apply the notion of SSC to their respective cities. It provides a guide for the implementation of SSC based on intensive use of ICTs, and refers the reader to a series of thematic reports, prepared by the FG-SSC, that address the specific technical aspects involved in the design and operation of SSC strategies (Annex 1).

While building upon expertise available in the field, this document is intended to be as general and inclusive as possible. It aims to inform the design of SSC strategies of any city irrespective of its size, location or resource availability, both in developed and developing countries.

The concepts and definitions presented in the document are in alignment with the technical reports and specifications produced by the FG-SSC as part of its contribution to the work of ITU-T Study Group 5 (SG5) on Environment and Climate Change<sup>7</sup>.

The composition and scope of work of the FG-SSC are summarized in Box 1.

---

<sup>7</sup> Further information on the work of ITU-T SG5 is available at: <http://www.itu.int/en/ITU-T/studygroups/2013-2016/05/Pages/default.aspx>



**Box 1 – FG-SSC: Composition and Scope of Work**

Established in February 2013 by ITU-T Study Group 5, the **Focus Group on Smart Sustainable Cities** provides a platform to share views, develop a series of deliverables, showcase initiatives, projects, policies and standard related activities that are taking place in the area of smart and sustainable cities. It also analyzes ICT solutions and projects that promote environmental sustainability in cities. It is composed of four Working Groups (WG), focussing on the following tasks:

- **Working Group 1** is focused on providing an overview of current state-of-art of SSC. The most important results of this group is the proposed definition of SSC and an overview which define the different parameters which currently outline a smart sustainable city and the role of ICT in this urban environment, as the glue which integrates all the other elements as a foundational platform.
- **Working Group 2** is responsible for identifying the technologies and city service infrastructures needed in the city, specially focused on ICT. It aims to look into future trends and to identify standardization gaps. This working group has developed several technical reports focused on the infrastructure and ICT based services needed in SSC, including: smart buildings, smart water management systems, security and resilience structures, among others.
- **Working Group 3** focuses on defining the Key Performance Indicators (KPIs) that will allow the evaluation of the city's transformation into a smart sustainable city, using a new integration model of technology vis-à-vis city services. This working group has also identified the standardization roadmap gaps which is helpful for the standardization activities related to the development of SSC.
- **Working Group 4** is responsible for identifying all the stakeholders that need to be involved in a smart sustainable city, as well as identifying the major challenges that they could face in its implementation. This group also has the task to identify key stakeholders within the SSC standardization and non-standardization activities worldwide, in order to disseminate and share the outcomes of the focus group.

Source: ITU (2014). Further information is available at: <http://www.itu.int/en/ITU-T/focusgroups/ssc>

## 2 *SSC definition*

The emergence of the 'Smart City' notion has been accompanied by a plethora of definitions and terminology related to smartness, sustainability and innovation within urban settings. Recognizing the need for a standardized definition of SSC, the FG-SSC commissioned the preparation of a technical report aimed at exploring available literature on the subject, analysing existing definitions of smart cities and sustainable cities from academic, private sector, government, and NGO sources, and identifying the factors that lay at the core of the SSC's concept.



Based on the analysis of more than one hundred definitions of what constitutes a smart sustainable city, the Technical Report on "*Smart sustainable cities – an analysis of definitions*"<sup>8</sup> identifies a series of key attributes that are intrinsic to this notion, most notably:

- a) **Sustainability** – This is related to the city's infrastructure, governance, energy and climate change, pollution and waste management, socio-economic aspects and health provision.
- b) **Quality of Life** – A crosscutting issue, the quality of life of the citizens and the initiatives in place to continuously improve it, are vital to the strategic vision and identity of SSC.
- c) **Intelligence or Smartness** – A "smart" city exhibits implicit or explicit ambition to improve economic, social and environmental standards. Commonly quoted aspects in definitions reviewed in the report include: Smart Economy, Smart People, Smart Governance, Smart Mobility, Smart Living and Smart Environment.

These attributes are present across four intersecting dimensions of complex urban systems, where SSC functionalities take place:

- **Societal:** The city is for its inhabitants (i.e., the citizens).
- **Economic:** The city must be able to thrive – create and sustain jobs, growth and finance.
- **Environmental:** The city must be sustainable in its functioning for future generations.
- **Governmental:** The city must be robust in its ability to administer and implement policies, and bring together different actors.

Ultimately, the review conducted in the report identifies a series of key issues that should be considered a part of a comprehensive understanding of SSC's role, namely its ability to:

- Improve the quality of life of its citizens.
- Ensure tangible economic growth, including higher standards of living and employment opportunities for its citizens.
- Improve the wellbeing of its citizens including medical care, welfare, physical safety, education, social inclusion and culture.
- Establish an environmentally responsible and sustainable approach, which "meets the needs of the present generation without sacrificing the needs of future generations".
- Streamline physical infrastructure-based services, including those related to the transportation (mobility), water, utilities (energy), telecommunications, and manufacturing sectors.
- Reinforce prevention, resilience capacities and handling functionality for natural and man-made disasters, including the ability to address the impacts of climate change.
- Provide an effective and well-balanced regulatory, as well as compliant governance mechanisms with appropriate and equitable policies and processes in a standardized manner.

Based on the outcomes of this research, numerous contributions from FG-SSC members and collaborating institutions, as well as on extensive discussions, held as part of the focus group's meetings, the following SSC definition was proposed and agreed:

---

<sup>8</sup> FGSSC (2014). 'Smart sustainable cities – an analysis of definitions'. Focus Group on Smart Sustainable Cities Working Group 1, International Telecommunications Union (ITU). <http://www.itu.int/en/ITU-T/focusgroups/ssc/>

*"A **smart sustainable city** is an innovative city that uses information and communication technologies (ICTs) and other means to improve quality of life, efficiency of urban operation and services, and competitiveness, while ensuring that it meets the needs of present and future generations with respect to economic, social, environmental as well as cultural aspects".*

Source: ITU-T Study Group 5 and UNECE, 2015.

Having established a comprehensive working definition of SSC, the following section identifies the key technical specifications that provide an enabling environment for the design and implementation of SSC strategies.

### **3 Building a master plan: towards an integrated management in SSC**

---

Emerging experiences aimed at the design and realization of SSC have evidenced that there is no single approach to make a city smarter and more sustainable. Each city constitutes a unique system, where different actors and city agencies, undertaking a range of activities, interact at multiple scales, using different facilities and infrastructures. Recognizing the particular environmental and societal contexts of the city, its purposes priority actions, as well as its history and characteristics, has become crucial not only to ensure effective governance, but also to determine the most appropriate path towards becoming smart and sustainable.

Local administrations need to prepare municipal strategic plans as frameworks for the implementation of Smart Cities initiatives; optimise urban services and tailor them towards citizens; move away from standardised and uniform service models to models that involve the provision of personalised services; develop transparent tariff systems, which reflect the real cost of providing services to citizens; create small big data with useful information about KPIs and develop integrated technological platforms that enable the management of intelligent cities.

Building on the work conducted by the FG-SSC, the SSC Master Plan presented in Figure 1 provides an overview of the key components and stages involved in the process of building “an integrated management scheme for SSC.

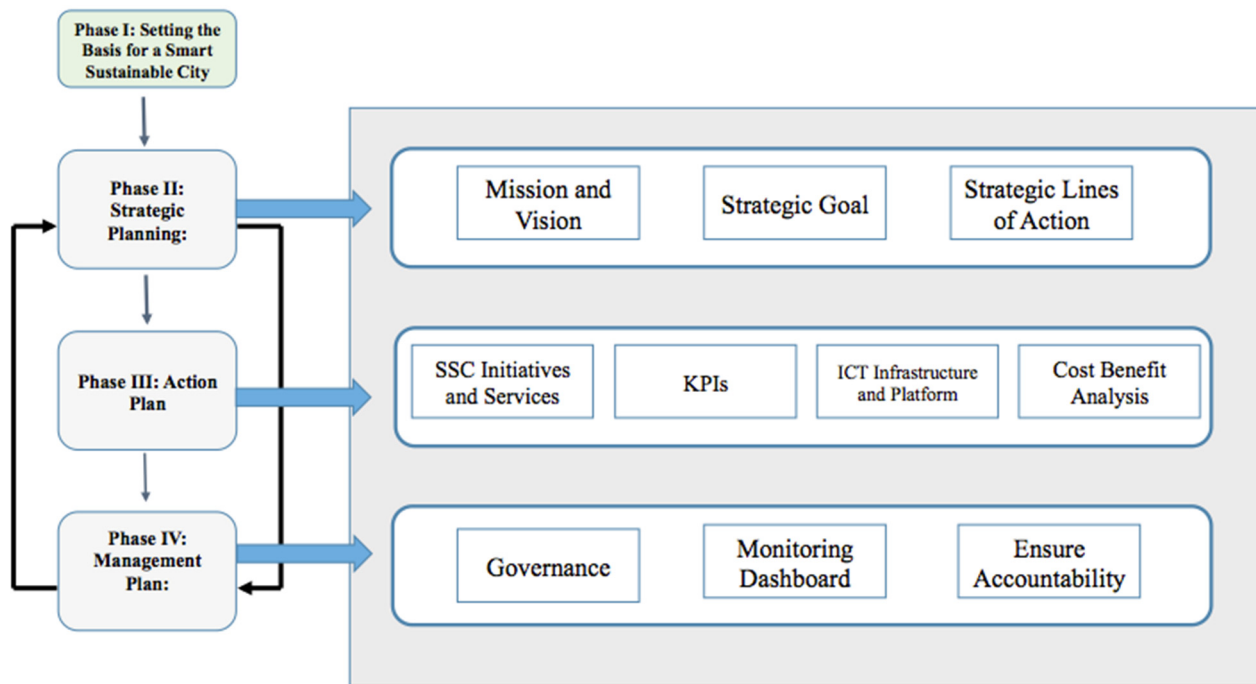


Figure 1 – Stages of Action: SSC Master Plan

### 3.1 Phase 1: Setting the basis for a Smart Sustainable City

Cities that decide to become smart and sustainable have to start by determining their motivations and priorities, including the identification of the stakeholders that need to be involved, the implications of this transformation on the city's governance, as well as the mechanisms needed to ensure continuous citizen participation and feedback throughout the process (in the short, medium and long-term, and across scales).

Setting the basis for a smart sustainable city, is largely based on gaining a clear, yet in-depth understanding of what it means to become a 'smart sustainable city', and what the process would entail (e.g., basic FG-SSC technical specifications).

As stated in the preceding sections of the analysis, the concept of SSC is extremely broad, and there are multiple and often competing approaches on how to achieve goals related to 'smartness' and 'sustainability' within urban settings. The concept of a 'smart city' also varies significantly in different regions. For instance, Latin American SSC perspectives are strongly focused on the improvement of security, local government management and mobility, Asian SSC initiatives emphasize the importance of infrastructure and services provided to the citizens with the trend of urbanization, while European SSC approaches often concentrate on the improvement of public services' efficiency to strengthen citizens' well-being.

Seeking to address this lack of consensus in the understanding of SSC, the FG-SSC – WG 1 worked on the identification of a comprehensive definition of SSC, presented in section 2 of this report. This definition recognizes the pivotal role played by ICTs as enablers of sustainable and efficient city services.

Further information on the notion and attributes of SSC, and the role of ICTs are available at:

- FG-SSC deliverable (2014), Technical Report on *“An overview of SSC and the role of ICT”*.
- FG-SSC deliverable (2014), Technical Report on *“Smart sustainable cities: an analysis of definitions”*.

Also involved in this first stage of implementation, is the definition of a baseline identifying the city's strengths and weaknesses, and defining clearly the priorities and objectives, as the city moves towards the obtaining of smart sustainable city status. This baseline must be defined in an empirical and standardized way through the use of indicators.

In this regard, it is important to recognize that for SSC strategies to succeed over time, they need to be well articulated and aligned with existent approaches to urban planning, so as to ensure that smart technologies, infrastructures and city services respond to a broader, more holistic vision of the city. Understanding the urban system, its goals, operation, gaps and opportunities, is a necessary step that should precede, and serve as a foundation for, the implementation of SSC strategies.

Identifying the city's purposes and existing urban planning goals, will help determine the priority actions in their path towards becoming a smart sustainable city – i.e., the common solutions the city would want to implement first, the areas of focus in the short, medium and long term.

Thus, the identification of city purposes/priorities of action, governance and stakeholders are closely interlinked, and are vital to form a robust basis for the design of SSC. Along with the set of stakeholders and their roles and responsibilities within the SSC framework, decision makers need to define a governance model and leadership strategies required for the city's transformation.

Thus, the establishment of a cross-sectorial body that can provide continuous support to city council officials and decision makers could contribute to a coherent design and implementation of smart and sustainable cities over time. This body could help ensure the articulation of SSC strategies and the city's urban planning goals, as well as facilitate collaboration and strategic alignment between the multiple stakeholders (including city-level departments and structures at local, municipal and national levels) that need to be involved in the realization of SSC.

The ITU-T FG-SSC – WG 4 have developed a technical report that identifies key SSC stakeholders, as summarized in Box 2.

**Box 2 – SSC Key Stakeholders**

- **Municipalities: City Council and city administration:** They are responsible for city management, and therefore they are the main promoters of SSC initiatives for each specific city.
- **National and regional governments:** They have remit on policies that can affect SSC implementation.
- **City services companies:** They would be implementing SSC solutions to increase the efficiency of city services.
- **Utility providers:** They are responsible for the deployment of some of the features of SSC such as smart grid or smart water management.
- **ICT Companies (Telecom Operators, Start-ups, Software Companies):** They are the providers of the global and integrated solutions, the city platforms, as well as the ICT infrastructure to support SSC deployment.
- **NGOs:** These NGOs are involved in all initiatives that can influence society and therefore are considered a stakeholder in SSC, especially on the axis of social sustainability.
- **International, Regional and Multilateral Organizations:** They include UN agencies and multilateral organizations. They can be promoters of initiatives towards human development, environmental sustainability and improvement of quality of life worldwide. They can offer funding opportunities, and are promoters of SSC initiatives.
- **Industry associations:** As industries are interested in the deployment of SSC, industry associations also work towards the success of this new model.
- **Academia, research organizations and specialized bodies.** They study SSC and associated trends, including its impacts and contributions to sustainable development.
- **Citizens and citizen organizations:** As inhabitants of cities, citizens are affected both directly and indirectly by SSC deployment.
- **Urban Planners:** The expertise of these urban planners is important to better understand how to include ICTs into medium and long term city planning, as well as to consider urban complexities.
- **Standardization bodies:** These organizations are critical to ensure a common terminology and minimum characteristics of a smart sustainable city, as well as to define measurement methods to assess the performance and sustainability of city services based on ICT technologies.

Source: ITU-T FG -SSC, ITU (2014)

A crucial step for setting an inclusive and sustainable basis for SSC consists of identifying and implementing effective mechanisms for citizen engagement. Citizens are the ultimate beneficiaries of SSC functionalities, as these are aimed at increasing the access to and boosting efficiency of city services, in order to improve citizens' well-being.

While these mechanisms should be set up at the onset of the SSC's strategy, they should be maintained, monitored and adjusted throughout the process of implementation to ensure flexibility, as well as the provision of up-to-date information about the features and benefits that SSC can provide to its citizens.

Without relevant and timely information, citizens can perceive SSC projects as an unnecessary use of their taxes. It is, therefore, important to demonstrate transparency and accountability in terms of the investments made in SSC service provision, and the way in which these investments are having an impact on the citizens' quality of life.

A smart sustainable city needs to promote participation in crucial aspects of the city's functioning, like participatory budgets. Citizenry can also play a key role in the provision of data to inform city-level decision-making processes (e.g., citizen as a sensor, real-time reporting/monitoring using social media), as well as in the provision of innovative ideas to improve city services, or to tackle emerging challenges through cost-effective approaches. In addition, it is very important to involve the companies in the design of the city in order to better understand their needs and facilitate investments made on their behalf.

SSC must be inclusive and enable access to those sectors of the population that may not have access to technology. To address this challenge, municipalities can offer training programs targeting marginalized populations (e.g., vulnerable women, the elder), equip public zones with technologies to broaden the user base, and implement other programs aimed at raising awareness and encouraging citizen engagement in the realization of the SSC strategy.

Further information on the role of SSC stakeholders is available at:

- FG-SSC deliverable (2015), Technical Report on *“Setting the stage for stakeholder's engagement in smart sustainable cities”*.

## 3.2 Phase 2: Strategic Planning

Progress needs to be made through holistic visions and transversal policies that strengthen the integrated approach, which should prevail in all SSC. Therefore, initiatives for SSC should consider metropolises from a global perspective; otherwise, the effectiveness and scope of such initiatives may be severely reduced.

In the first step of the cycle, local governments identify a SSC vision and assess the city's situation in order to establish the relevance and feasibility of becoming a SSC. This step includes, among others:

- To define, what kind of city it should be. What are the overall aims of the initiative and what is the main idea to achieve specific targets?
- Identifying a SSC vision that is line with the city's identity, political priorities and long-term development strategy;
- The vision establishes the connection between the SSC components and its guiding principle. This is necessary to provide a deeper understanding of the vision of a smart sustainable city;
- Document the detailed business process of the main existing city services along with their inter-relationships and dependencies;
- Gathering relevant data on the status of ICT infrastructure and usage at the city-level, including the status of the city in regards to the SSC technical specifications;



- Identifying the existing governance and organizational conditions that would allow an efficient and effective management of SSC solutions;
- Identifying mechanisms for multi-stakeholder involvement, citizen engagement, communication and information sharing throughout the SSC process. Assurance of the participation of citizens and relevant stakeholders in SSC is essential for the transformation process into a smart sustainable city; and
- Encourage the two ways of participation; top-down or a bottom-up approach. A top-down approach promotes a high degree of coordination, whereas a bottom-up approach allows more opportunity for common people to participate directly.

In this phase, it is crucial to understand the city as an ecosystem. This ecosystem should be created by entities which are involved in the process of development of SSC strategies, including universities, research centers, companies, public agencies and society

In this phase, local governments should achieve the necessary political approval and legitimization to ensure that the SSC strategic program is pursued. It consists of the adoption of the SSC program/targets by the local council through a political decision, thus becoming an agreed document that has widespread support. This would also serve as a reference for the strategic planning of the local authority.

Any SSC initiative should have a strong political leadership from the local government. Additionally, it will be necessary to identify within institutions, organisms and/or businesses involved, the people with greater level of leadership. Such leadership should be conveyed through the initiative of project administration, the constant co-ordination between the relevant actors, the decision-making, the overcoming of challenges and any other action to guarantee the continuous development of the project.

### 3.3 Phase 3: Action Plan

An action plan involves turning a suggested project into something tangible. This in turn requires a clearly defined plan for integrating technology solutions into an action plan. Important considerations can include: timing of the action; the costs related for implementation; the identification of who are individuals or agencies responsible for implementation; progress indicators; procedures for reporting and evaluation.

In this phase, local governments work in close collaboration with the various SSC stakeholders to design the overall plan for the SSC's implementation (e.g., objectives, priorities, initiatives and actions needed in the short, medium and long term, including SSC infrastructure investments, setting measurable SSC targets and time frames for their achievement). This step involves, the identification of SSC targets and major milestones with regards to:

- SSC services;
- SSC Key Performance Indicators (KPIs);
- SSC architecture;
- SSC infrastructure and integrated platform;
- SSC data security, EMF ; and
- SSC projected cost benefit analysis.

A plan of action must be elaborated which proposes a series of realistic development measures. Such measures will be hierarchized and studies will be done with regards to associated costs and

the appropriate period when investment should take place. A clearly established plan of action will be the guide for development of actions and strategies. A strategy will be designed which has quick-wins, which will be instrumental in the creation of public and private support needed for the success of SSC initiatives and systems such as:

#### a) Smart Sustainable Cities Services

Cities provide many different services to its citizens, including water management, energy, transport, waste management, healthcare, education and security. The efficiency of these services can be significantly improved with the use of ICT technologies, creating a new set of "smart services" which will lead to improved efficiency and sustainability.

Every municipality should evaluate the different services that their city might need. The work conducted by the FG-SSC working groups, have allowed the identification of several ICT services that contribute to the efficiency of city services, as summarized below:

- **Smart Water Management Systems:** These systems promote the sustainable management of water (water supply and distribution, water and wastewater treatment and other municipal related services like raw water services, drainage services or reclaimed water services) through coordinated water management by the integration of ICT infrastructure (products, solutions and systems) in order to maximize the socioeconomic welfare of a society without compromising the environment<sup>9</sup>.
- **Smart Energy Management Systems:** These systems use sensors, advanced meters, digital controls and analytic tools to automate, monitor and control the two way flow of energy, optimizing grid operation and usage, to ensure reliability, self-healing, interactivity, compatibility, energy saving, safety, optimal use of energy from renewable sources and minimum carbon footprint. ITU-T Focus Group on Smart Grids has developed several documents in this field<sup>10</sup>.
- **Smart Transportation Management Systems:** These systems need to move people (and goods) in an efficient, timely and cost effective, safe and environmentally sustainable way. With that aim in mind, they need to use technology (e.g., M2M communication, Wi-Fi and RFID technologies, Global Positioning Systems, sensors) and collect information (e.g., real-time traffic flow information, data analytics, prediction techniques) about mobility patterns. Some added benefits of these systems include the capability to locate and identify vehicles, and monitor and control infrastructures like roads. As a result, it is possible to reduce travel times, incident duration and traffic accidents.
- **Smart Waste Management Systems:** These systems will empower the implementation of waste tracking systems based on their ability to monitor the movement of different kinds of waste, optimize collection routes, connect various smart waste management systems with local service providers, leverage technology to collect and share data from waste sources, to waste transportation, disposal and sorting. These upgrades will help to convert waste into a resource and create closed loop economies, fostering more sustainable and productive uses of waste.

---

<sup>9</sup> ITU FG-SSC (2014) Technical Report on "Smart water management in cities".

<sup>10</sup> <http://www.itu.int/en/ITU-T/focusgroups/smart/Pages/Default.aspx>

- **Smart Healthcare Management:** These management systems can convert health related data into clinical and business insights, and enable secure communications and information sharing in order to improve the productivity of the service provided to citizens. Examples of smart healthcare systems include the availability and improvement of remote diagnosis, remote treatment, on-line medical services, health management systems and remote patient monitoring systems. To achieve these goals, M2M communications will be crucial.
- **Smart Education:** Education, for adults and children, may be the most important smart city service. The use of ICT can improve education by providing the student with a personalized learning environment (e.g., tailored to his progression level, interests, learning style), as well as by providing educators with new tools to design learning activities or opening new communication channels with student, parents and community members. At the city level, the use of ICT in education can generate other economic and social benefits, including the improvement of tourism services.
- **Smart Security:** Ensuring physical safety and security required, the use of ICTs responds to the need of resolving incidents, providing criminal identification, as well as conducting predictive analysis and criminal pattern identification to improve the citizen safety. Command and control systems shared across multiple city departments like energy, waste, transport and security will be needed to provide a holistic city-wide view of safety patterns and trends. New ICT infrastructure also has to be protected from security threats.
- **Smart Buildings Systems:** These systems can use data to improve building energy efficiency, reduce wastage and optimize water usage, without affecting the occupants' satisfaction. These systems may include building automation, life safety, and telecommunications, among others.

Further information on ICTs and Smart City Services is available at:

- FG-SSC Technical Report on “*Overview of SSC infrastructure*”
- FG-SSC Technical Report on “*Intelligent sustainable buildings for smart sustainable cities*”.

The analysis conducted thus far suggests that ICT use can improve the efficiency of city services and, ultimately, strengthen the quality of life of its citizens. To assess these benefits, Key Performance Indicators (KPIs) are needed to quantify and evaluate the transformation of a city into a smart sustainable city. Other KPIs that are specifically designed for each city service, are also needed to monitor performance and assess, quantitatively, the efficiency gained through the implementation of SSC solutions.

While the list of smart services provided earlier reflects the standard/most common city services, municipalities can integrate different services according to their own needs and priorities.

#### **b) Key Performance Indicators, Standards.**

Key Performance Indicators (KPIs) are not only useful to evaluate the performance of city services, but can also be used to assess, empirically, how one or a set of modifications contribute to the city's transformation into a smart sustainable city, providing ground for standardization. KPIs can also allow comparisons between different cities to determine which one is 'smarter' or more sustainable in the face of particular challenges. Evaluating these indicators can help cities as well as their stakeholders understand to what extent they may be perceived as Smart Sustainable Cities (SSC).

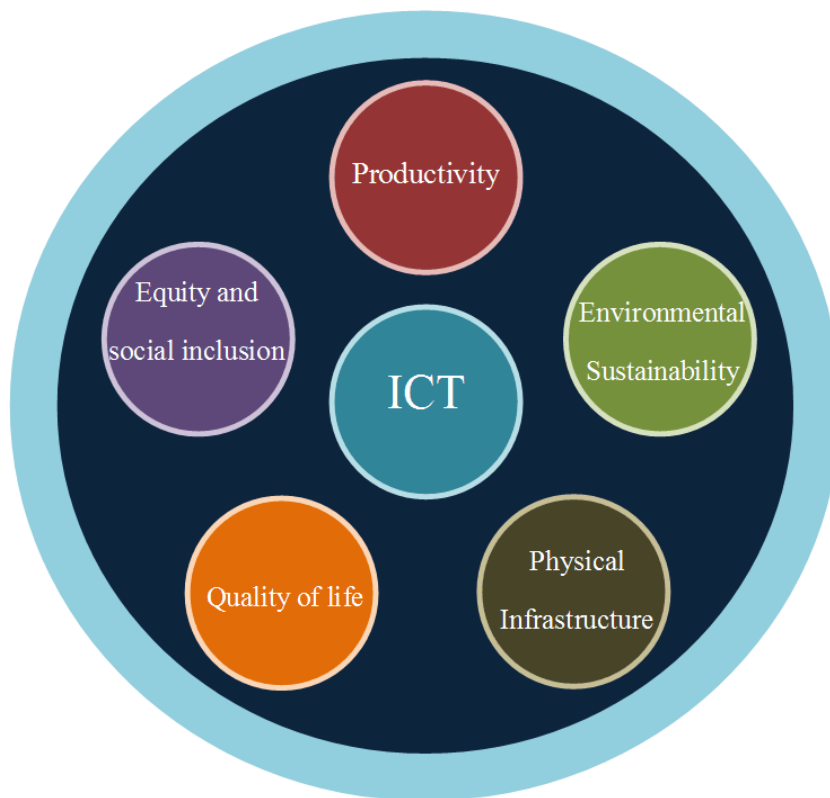
In order to provide a complete list of KPIs that can be used for city and municipal administrations, city residents, development and other organizations of operating in SSC (e.g., producers, service providers, planning units), as well as evaluation or ranking agencies, the FG-SSC has developed a series of documents:

- Technical Specifications on “Overview of key performance indicators in smart sustainable cities”.
- Technical Specifications on “Key performance indicators related to the use of information and communication technology in smart sustainable cities”.
- Technical Specifications on “Key performance indicators related to the sustainability impacts of information and communication technology in smart sustainable cities”.
- Technical Report on “Key performance indicators definitions for smart sustainable cities”.

The Technical Specifications define standardized KPIs with the aim to provide criteria to evaluate existing cities (e.g., single cities from the administrative point of view, or the union of small cities in the same area that share some services), but not to compare them. It will enable cities and municipal administrations to understand the progress of SSC development and design suitable strategies, city residents to know the details of development of SSC, and development and operation organizations of SSC to fulfil the tasks related to information provision.

The evaluation principles chosen to define dimensions, sub-dimensions and indicators are the following: comprehensiveness (i.e., should cover all SSC aspects), comparability (i.e., should be able to compare scientifically different phases of urban development and different cities), availability (i.e., quantitative data must be accessible and scientific), independency (i.e., the indicators in the same dimension must be independents), simplicity (i.e., concepts and calculation must be simple and intuitive) and timeliness (i.e., ability to produce KPIs with respect to emerging issues in SSC construction). The dimensions of KPIs can be categorized as follows (shown in Figure 2):

- Information and Communication Technology
- Environmental sustainability
- Productivity
- Quality of life
- Equity and social inclusion
- Physical infrastructure



**Figure 2 – Dimensions of evaluation of SSC**

Source: FG-SSC<sup>11</sup>

Using the evaluation principles explained before, the key performance of SSC can be categorized into six dimensions, each with their respective sub-dimensions and indicators, as follows:

**Table 1 – SSC: KPIs, Dimensions and Sub-dimensions**  
**Overview of key performance indicators in smart sustainable cities**

Dimension label	Dimension	Sub-dimension label	Sub-dimension
D1	Information and Communication Technology	D1.1	Network and access
		D1.2	Services and Information platforms
		D1.3	Information security and privacy
		D1.4	Electromagnetic field
D2	Environmental sustainability	D2.1	Air quality
		D2.5	Water, soil and noise
D3	Productivity	D3.1	Capital investment
		D3.4	Trade
		D3.8	Innovation
		D3.9	Knowledge economy

<sup>11</sup> ITU FG-SSC (2014) Technical report on "Key performance indicators definitions for smart sustainable cities".

Dimension label	Dimension	Sub-dimension label	Sub-dimension
D4	Quality of life	D4.1	Education
		D4.2	Health
		D4.3	Safety/security public place
D5	Equity and social inclusion	D5.3	Openness and public participation
		D5.4	Governance
D6	Physical infrastructure	D6.1	Infrastructure/connection to services – piped water
		D6.2	Infrastructure/ connection to services – sewage
		D6.3	Infrastructure/ connection to services – electricity
		D6.8	Infrastructure/connection to services – road infrastructure
		D6.11	Building

Source: ITU-T FG-SSC (2014)<sup>12</sup>

The corresponding indicators for each sub-dimension are detailed in the "Technical Specifications on key performance indicators related to the use of information and communication technology in smart sustainable cities" and "Technical Specifications on key performance indicators related to the sustainability impacts of information and communication technology in smart sustainable cities".

### c) Setting the framework for ICT architecture of smart sustainable cities

The architecture of smart sustainable cities has been defined in the corresponding FG-SSC Technical Specification on "Setting the framework for an ICT architecture of a smart sustainable city" (fg-ssc-0345). At a high level, a Meta-Architecture consists of 5 layers (as depicted in Figure 3), which focus on the integration between natural environment and soft infrastructure of urban spaces, while SSC services run across these layers.

<sup>12</sup> ITU FG-SSC (2014), Technical report on "Key performance indicators definitions for smart sustainable cities".



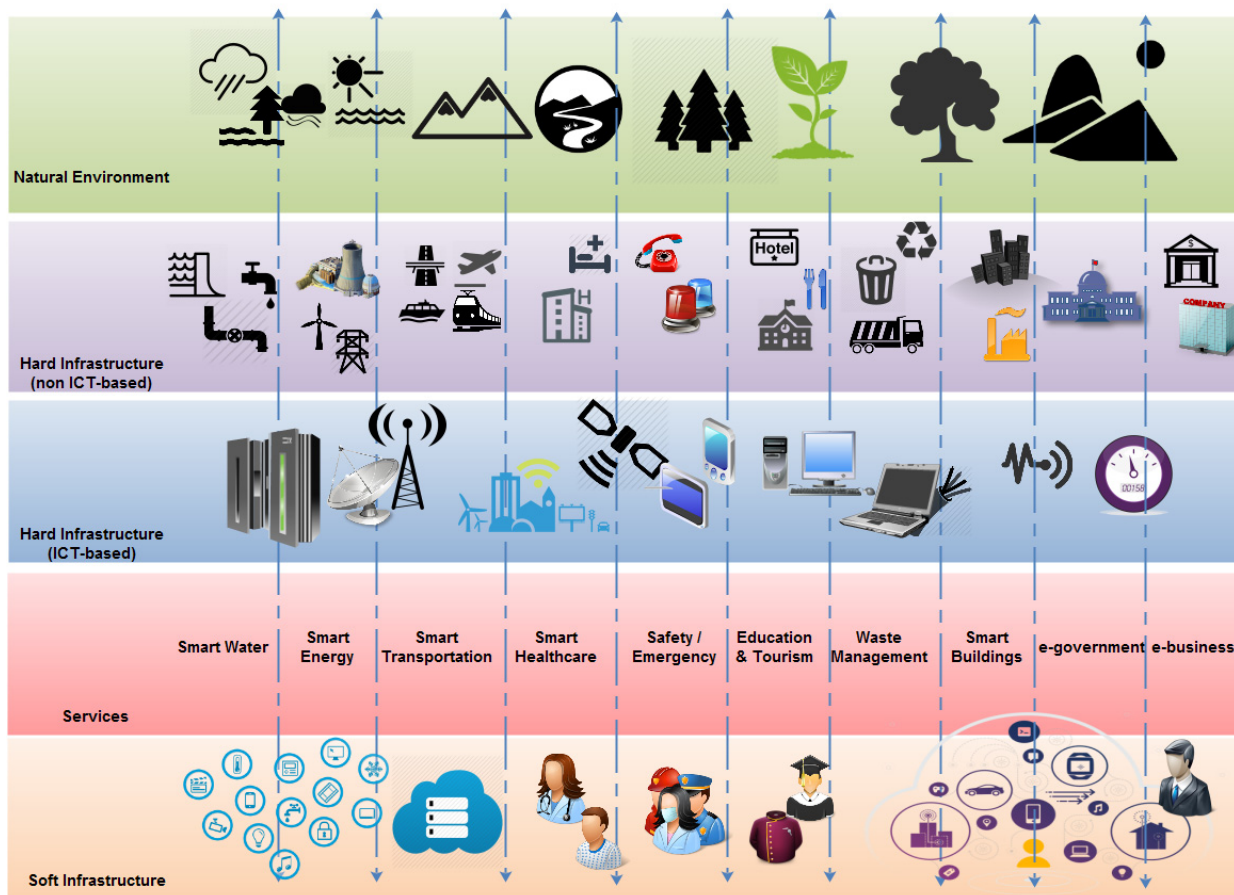
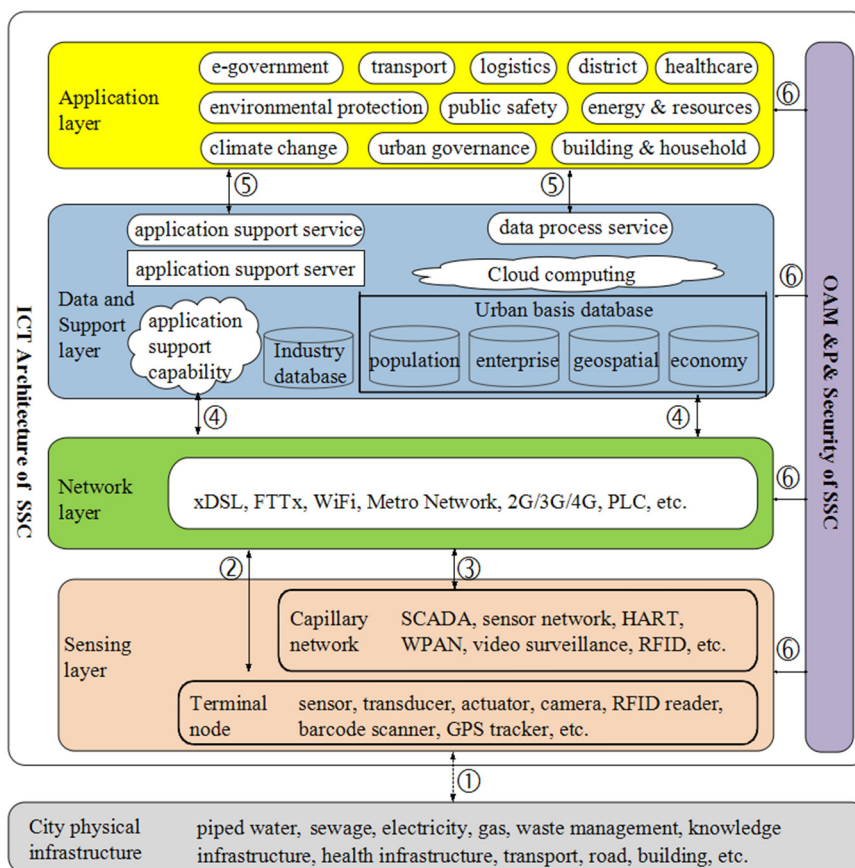


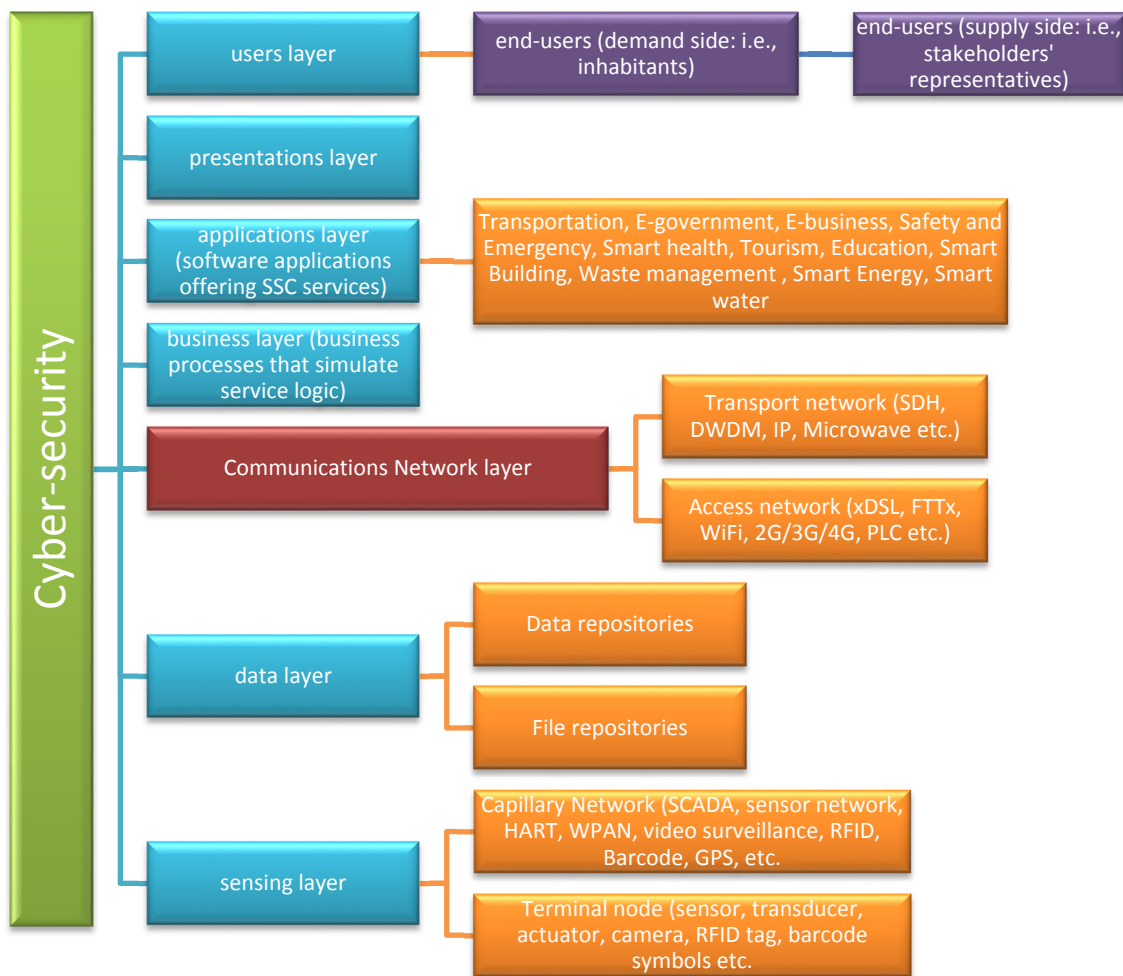
Figure 3 – Multi-tier SSC ICT meta-architecture<sup>13</sup>

A smart sustainable city can also be considered a system of subsystems. With regard to its technical definition, it can be viewed from different perspectives. Figures 4 and 5 demonstrate the communications view of the SSC ICT architecture, based on a physical and an information flow perspective respectively. Both perspectives of this view are multi-tier.

<sup>13</sup> Technical Specification on “Setting the framework for an ICT architecture of a smart sustainable city” (fg-ssc-0345)



**Figure 4 – A multi-tier SSC ICT architecture from communications view, emphasizing on a physical perspective**



**Figure 5 – A multi-tier SSC ICT architecture from communications view, emphasizing on an information flow perspective**

Both the given figures concern valid representations of the same architecture view, one closer to the language of infrastructure developers and the second more in line with the information system developer's context. The architecture view contains the following layers (as depicted in Figure 4):

- *Sensing layer:* This layer consists of terminal node and capillary network. Terminals (sensor, transducer, actuator, camera, RFID reader, barcode symbols, GPS tracker, etc) sense the physical world. They provide the superior “environment-detecting” ability and intelligence for monitoring and controlling the physical infrastructure within the city. The capillary network (including SCADA, sensor network, HART, WPAN, video surveillance, RFID, GPS related network etc.) connects various terminals to network layer, providing ubiquitous and omnipotent information and data.
- *Network layer:* The network layer indicates various networks provided by telecommunication operators, as well as other metro networks provided by city stakeholders and/or enterprise private communication network. It is the information superhighway (infobahn), the network layer data and support layer. The data and support layer makes the city “smarter”, its main purpose is to ensure the support capabilities of various city-level applications and services. Data and support layer contain the data centers from industries, departments, enterprises, as well as the municipal dynamic data center and data warehouse (etc), established for the realization of data process and application support.

- *Application layer:* The application layer includes various applications that manage SSC and deliver the SSC services.
- *OAM & P & security framework:* This layer provides the operation, administration, maintenance and provisioning, and security function for the ICT systems of SSC.

The multi-tier SSC ICT architecture from communications view, emphasizing on an information flow perspective (illustrated in Figure 5) contains the following layers:

- *Users layer:* It organizes SSC service end-users into groups from both the demand and the supply sides;
- *Presentations layer:* It contains the user interfaces (web, apps, voice commands etc.), which stand between end-users and SSC services;
- *Applications layer:* It contains all corresponding software applications that realize the SSC services;
- *Business layer:* It consists of the business processes, which lie behind each smart sustainable city service execution;
- *Communications layer:* It contains the above mentioned networks, over which the SSC services are performed and transactions and data flow are realized;
- *Data layer:* It contains the data and file repositories, where data are created or retrieved;
- *Sensing layer:* This layer consists of terminal node and capillary network. The terminals (sensor, transducer, actuator, camera, RFID tag, barcode symbols etc.) sense the natural environment where the smart sustainable city is located and the corresponding hard infrastructure and utilities (water, transport etc.). It provides the superior 'environment-detecting' ability and intelligence for monitoring and controlling the physical infrastructure within the city. The capillary network connects various terminals to communication layer, or directly to data layer and/or application layer providing ubiquitous and omnipotent information and data.

Detailed discussions on ICT Architecture and Architecture Framework, as well as security aspect of Smart Sustainable Cities is available in deliverables SSC-0345 "Setting the framework for an ICT architecture of a smart sustainable city" and SSC-0090 "Technical Report on ICT Infrastructure for Cyber-Security, Data Protection & Resilience", respectively of the Focus Group on Smart Sustainable Cities (FG-SSC).

#### d) Smart Infrastructure and Integrated Platform

Investing in ICT infrastructure constitutes a critical component of a city's transformation into a SSC. This technology can provide crucial information for city managers to increase the efficiency in urban services, improve the quality of life of citizens, ensure a tangible economic growth, strengthen prevention and management of natural disasters, simplify physical infrastructure used in some services (e.g., mobility, energy), and improve the city's sustainability.

In order to reduce as much as possible, this initial investment, cities can adopt the notion of "convergence", by using pre-existing networks to establish new ICT infrastructure.

The first step for introducing ICT technologies in cities is to consider all stakeholders involved in this process. In terms of interconnected infrastructure, the most relevant stakeholders will be the telecom operators, ICT providers, financial institutions, utility providers, emergency services, local institutions, NGOs, regulators, funding bodies, universities, as well as Research and Development (R&D) institutes.

The ICT infrastructure of SSC contains a vast array of technologies. The most important ones, grouped in three categories, are listed in Table 2:

**Table 2 – Technologies and Categories of SSC ICT**

<b>Network Facilities</b>	Data Layer
	Data/Content Center
	Communication Layer
	Transport Networks
	Access Networks
<b>ICT Facilities</b>	Network Management Software
	ICT Integrated Services Capacity
	Data Management
	Cloud Computing and Data Platform
	Geographic Information Infrastructure
	Augmented Reality
<b>Terminals, Sensing &amp; Multi-device layer</b>	Terminals & Gateways
	Sensors
	Internet of Things

Source: ITU-T FG-SSC, 2014<sup>14</sup>

FG-SSC WG 2 defines two different aspects related with the strategic planning required for the national deployment of ICT infrastructure.

The first one is the deployment of ICT infrastructure itself, including the formulation and implementation of related policies and strategies. It requires the involvement of all the stakeholders identified before. The second aspect refers to improving the infrastructure deployed in order to reduce defects like perception (e.g., the infrastructure is not able to automatically perceive themselves running), cleverness (e.g., the operation and application of facilities use a fixed configuration and it is unable to judge the situation automatically), lack of sharing mechanisms (e.g., lack of horizontal integration that prevents synergies) and communication restrictions (e.g., the bandwidth and reach of various branded communication facilities are uneven).

Decision makers must consider that during the implementation of ICT infrastructure there is the risk of creating a polarization effect in zones that have more investment than others, creating (or accentuating existing) digital divides in the city. Strategies aimed at addressing these risks can include the use of public funds to invest in zones with the least development infrastructure.

Municipalities can adopt different strategies for the development of ICT infrastructure. These include the provision of supply incentives, using existing infrastructure for the deployment of ICT, or the adoption of strategies to incentivize demand (e.g., using ICT to improve local service management, or to improve the relationship with citizens). It must be noted that supply and demand stimulate each other. An adequate supply will often push the demand, while the growth of demand can increase and improve the supply, fostering a virtuous circle. With that in mind, local governments should focus on both strategies.

All ICT infrastructure implementation must fulfil the applicable laws and regulations. In cases of municipal infrastructure and deployment of projects, financing strategies tend to be very heterogeneous.

<sup>14</sup> Ibid.

Some of the main funding mechanisms that can be used to support the activities involved in this stage are summarized in Table 3.

**Table 3 – ICT infrastructure funding methods**

Funding Mechanism	Description
<b>Taxes</b>	Pay using taxes
<b>Redemption from taxes (tax or rates)</b>	Local government taxing rights are exchanged for infrastructure or services
<b>Loans + Free Cash Flow</b>	Initial capital comes from financial leverage from partners. After that the project can try to sustain itself
<b>Local Government as a Major Customer</b>	Funds provided by city government
<b>Advertising</b>	Funds generated by advertising
<b>Utilities Allowance</b>	Funds collected from other public services used to maintain infrastructures. Some regulations prevent this system
<b>Corporate Donations</b>	Some corporations can donate funds
<b>Agreements with Private Companies</b>	Agreement with private companies to offer funds free of charge to the public
<b>National or Multinational Subsidies</b>	Funds coming from national or multinational organizations.
<b>Cooperative Projects</b>	Local government ends up with a project originally created as a cooperative and community project

Source: ITU-T FG-SSC, 2014<sup>15</sup>

Further information on the role of SSC infrastructure is available at:

- FG-SSC Technical Report on “*Overview of SSC infrastructure*”.

### e) Data Security and EMF

All cities need to consider two fundamental topics in order to protect their citizens in a new context of smartness and sustainability; *cybersecurity and data security*, to protect the citizen data, and *electromagnetic fields (EMF)*, to address existing concerns of the public around this topic.

#### Data Security

SSC apply the use of technologies in many different areas of the city (e.g., infrastructure, resource management, public services, industrial systems, social aspects, security). They do this in more extensive and intensive ways than traditional cities, and thus generate larger amounts of valuable data. This information is needed to improve the efficiency of cities. However, its management can be challenging.

One of the principal objectives of any city is to become a safe place to live for its citizens. In a smart sustainable city, citizens' security must be expanded to data security (i.e., cyber-security and data protection) in order to protect one of its most important resources.

<sup>15</sup> Ibid.



Considering the growing importance of this area, the FG-SSC developed the Technical Report on “Cyber-security, data protection and cyber-resilience in smart sustainable cities” to identify ways of improving cyber-security and cyber-resilience (defined by the Information Security Forum as the capacity to withstand negative impacts due to known or unknown, predictable or unpredictable, uncertain and unexpected threats from activities in cyberspace<sup>16</sup>).

In order to protect the city from these threats, SSC shall be provided with security systems that offers protection in four dimensions: physical and environmental security (e.g., equipment security, disaster recovery prevention), system security (e.g., anti-virus technology, host security reinforcement and operating system security), network security (e.g., gateway anti-virus, firewall and intrusion detection) and data and application security (e.g., database encryption and database backup technologies).

As a result of their complexity and significance within the city's operation, the security of some smart city services and infrastructures must be prioritized (e.g., smart grids, intelligent transportation, connected healthcare, public safety and security or wireless communications and hotspots).

The information security infrastructure constitutes the technical foundation of the entire system, and as such, it provides a large number of security functions. The tasks of the information security infrastructure centers include disaster recovery, emergency monitoring, key management, security management, security evaluation and identity management.

Further information on the technologies and actions that can be implemented to achieve the SSC's security is available at:

- FG-SSC Technical Report on “*Cybersecurity, data protection and cyber resilience in smart sustainable cities*”.

### EMF Considerations

SSC are based on the extensive use of wired and wireless ICTs, to provide city services in a more efficient way. Scientific research over many decades has enabled national and international health authorities to establish safety limits for human exposure to electromagnetic fields. Exposure limits vary depending on the EMF frequency and EMF source and incorporate conservative safety margins for added protection.

ICTs devices and networks should be designed and deployed ensuring EMF compliance, while supporting the maximum efficiency of ICTs' utilization.

Further information on the basic principles that SSC will need to consider when defining EMF policies is available at:

- FG-SSC Technical Report on “*Electromagnetic field (EMF) considerations in smart sustainable cities*”.

---

<sup>16</sup> <https://www.securityforum.org/>

#### f) SSC Projected Cost Benefit Analysis

Given the massive expected amounts of investments needed to realize the SSC concept, it is of extreme importance to conduct cost benefit analysis to analyze the feasibility of deploying such systems. Not only does the sustainability concept address environmental and societal challenges, but also includes issues related to the economic feasibility and long-term break-even on the micro and macro levels.

In the process of analyzing the different possibilities to achieve the set strategic targets, it is important to develop a technology market adoption model<sup>17</sup> which would be capable of estimating the needed investments using different SSC technologies combinations or options. The model should estimate the needed investments per SSC service sector, in addition to its financial viability and foreseen macro-economic impact. This quantitative analysis enables policy makers to establish the right combination of policy tools and strategic directives to create a robust SSC ecosystem.

### 3.4 Phase 4: Management Plan

This last phase includes the definition of the *City Governance* and the setting of the *Monitoring Dashboard* to evaluate city performance in the future.

This stage involves close coordination and collaboration among SSC stakeholders, as well as the implementation of Key Performance Indicators (KPIs).

The execution of each initiative must be carried out in accordance with the Action Plan. The necessary information must be made available in order to realize the initiative and learn from experiences. Additionally, it is in this implementation phase, where special attention must be paid to infrastructural needs.

This phase is also focused on evaluating, reporting and learning from the SSC process and related experiences. The results must be registered, measured and analyzed in order to identify the improvements made through the different initiatives.

The level of success of the SSC initiative will arrive through the economic, social and environmental results in the long term). This evaluation contributes to informing the high-level municipal decision-makers, as well as to informing the preparation of future baseline reviews to deepen SSC plans, among others. It can involve the use of various mechanisms for knowledge and experience sharing among the different SSC stakeholders.

The implementation process is the most crucial stage of any strategic plan. During this process one may face several challenges which include: defining the skills required for those responsible for its execution, defining the budget and related financial issues, establishing progress indicators, evaluating the results and presenting the findings to the stakeholders<sup>18</sup>:

1. Governance of Implementation: For the purpose of implementation of the master plan, a governance committee should be set up. The members of this governance committee should be people who worked on the development of the master plan first hand. The governance committee will be in charge of reinforcing the competences in budgetary control, and should be able to specify relevant agreements, and develop a communication plan.

---

<sup>17</sup> eMisr, National Broadband Plan, Egypt, 2011 available at: <http://www.tra.gov.eg/emisr/Documents.aspx>

<sup>18</sup> Fernández Güell, J.M. (2006) – Planificación estratégica de ciudades: Nuevos instrumentos y procesos, Barcelona: Editorial Reverté.

2. **Financing Model:** Even though there are various methods to fund a project and these methods may vary in each city, common criteria should be included, when using such methods. These include stability, diversification, balance, and adaptability. The members of this committee should be people who worked on the development of the master plan first hand. However this should reinforce the competences in budgetary control, and should be able to specify the agreements, and develop a communication plan.
3. **Evaluation Model:** For this model, it is important to differentiate the evaluation of specific smart sustainable city projects or examine a holistic vision of smart sustainable city developments. Furthermore, the constant monitoring of external factors, and the choice of evaluation methods of key issues is needed. By doing so, it is possible to obtain better control of the evolution of the economic execution plans, deadlines and the upgrading of existing KPIs.
4. **Dissemination and Communication:** The master plan will be followed by a communication strategy in order to maintain interest in the process. Instruments such as the creation of a corporate image for the project, outreach publicity, publication of technical documents (etc) will support this objective.

## 4 *Conclusions and key considerations*

---

In order for a smart sustainable city initiative to be adopted and succeed, it is important to understand the need for such vision and ambition. Accordingly, some considerations must be taken into account.

- The SSC initiative must have a strong political leadership from the local government. Such leadership must be shown through the administration of the project, the constant co-ordination between the relevant actors, the decision-making, the change management, customize training, by overcoming challenges and any other action necessary to guarantee the development of the project. The designation of responsibilities is key in order to ensure success.
- The set of objectives must be clear and must allow for the quantifiable evaluation of results obtained.
- The continued evaluation of results is fundamental to show the value of the initiatives developed and the role of indicators (KPIs) is key and must be significant.
- Develop models of public-private collaboration, as they are powerful alliances, leading the ecosystem of innovative actors to obtain success. The planning must facilitate a scenario of mutual benefits between all agents, while the role of the administrator will be to facilitate the relationship between all agents.
- On the other hand, if SSC are about efficiency and a better quality of life, they must support important economic savings or the implementation of new services. A serious study must take place regarding the financial aspects of the initiative and also the future administration of financial resources. Here, the public-private collaboration plays a key role.
- Citizens should be recognized as the cornerstone of any smart sustainable city. They are the main beneficiaries of the SSC model that can provide valuable data, ideas and feedback to the city. Consequently, the city has to actively promote and enable citizen participation.

In any event, understanding the city as an open ecosystem, to promote open areas of collaboration, through co-working, accelerators program and urban labs, makes mechanisms become available in order to naturally incorporate the collective intelligence and the areas of co-creation.

The collaboration between the ecosystem's actors in the city as well as the collaboration between cities, can be made available and improved through the use of ICTs which allow collaboration tools and integration initiatives more realistic and efficient, reason why the public-private initiatives are key. It is very important to learn from past initiatives and experiences.

It is very important to adopt, at different levels of decision, common and shared policies of ICT tools and solutions, combined with organizational changes and the acquisition of new skills in order to generate savings and greater productivity of the city's administration that can have a positive effect on the increasingly tight budgets. Investing in ICT also produces great benefits for the city's economy, boosting productivity through incentives and the creation of new jobs.

As experiences continue to emerge around the globe, it is crucial to recognize that the effectiveness of SSC strategies requires a holistic, articulated approach that is not solely based on technological and infrastructural aspects, but primarily on improving the citizen's well-being.

Installing smart technologies alone will not improve city services. SSC are about strategic integration and articulation. New technology needs to be complemented by intelligent management. In this sense, strategists will need to define how technologies and information collected will be used, considering that a key characteristic of SSC, is the breakdown of silo-based approaches, and the integration of services to improve the quality of life of citizens. Thus, considering the different stages and components of the Master Plan presented in this report, as well as the set of technical reports produced as part of the FG-SSC's mandate, can help to guide and inform that process.

## References

Fernández Güell, J.M. (2006) – Planificación estratégica de ciudades: Nuevos instrumentos procesos, Barcelona: Editorial Reverté.

Greenfield, A. (2013) – Against the smart city, New York: Do projects.

Iván Tosics January 2011, Governance challenges and models for the cities of tomorrow,

Directorate-General for Regional and Urban Policy, Brussels

Kooiman, J. 1990, Modern Governance, Sage. London.

Manville, e.a. 2014, Mapping Smart Cities in the EU, Policy Department Economic and Scientific Policy, European Parliament, Brussels.

Kauffman, S. (1995) – At home in the Universe: The search for the laws of self-organization and complexity, Nueva York: Oxford University Press.

Townsend, A. (2013) – Smart Cities. Big data, civic hackers and the quest for new utopia, New York: W. W. Norton & Co.

Von Bertalanffy, L. (1968) – General Systems Theory: Foundations, Development and Applications, New York: Braziller.

Waldrop, M. (1992) – Complexity: The Emerging Science at the Edge of Order and Chaos, New York: Simon & Schuster.











# 2.5

## Setting the stage for stakeholders' engagement in smart sustainable cities

Technical Report

## Acknowledgements

This Technical Report was researched and written by Daniela Torres (Telefónica), Jara Forcadell Ortiz (MSc on Smart Cities at University of Girona, Spain) and Mythili Menon (University of Geneva) and as a contribution to ITU-T Focus Group on Smart Sustainable Cities (FG-SSC).

Special thanks are due to Angelica Ospina (University of Manchester), Giampiero Nanni (Symantec Corporation), Juan Manuel Sabio Morchio (University of KwaZulu-Natal, South Africa), Marc Gil (MSc on Smart Cities at University of Girona), Amanda Mc Intosh (Carlo-Schmid Programme), Chris Ip (University of Toronto), José Miguel Fernández Güell (Universidad Politécnica de Madrid), Ziqin Sang (Fiberhome), Guilherme Canela (UNESCO) and Silvia Guzmán (FG-SSC Chairman) for their helpful review and contribution.

Additional information and materials relating to this report can be found at: [www.itu.int/itu-t/climatechange](http://www.itu.int/itu-t/climatechange). If you would like to provide any additional information, please contact Cristina Bueti at [tsbsg5@itu.int](mailto:tsbsg5@itu.int).

## Table of Contents

		Page
<b>1</b>	<b>Smart sustainable cities: overview and challenges .....</b>	<b>176</b>
1.1	SSC overview.....	176
1.2	SSC challenges .....	177
<b>2</b>	<b>Methodology for SSC stakeholder identification and engagement.....</b>	<b>181</b>
2.1	Identification of all stakeholders involved in SSC.....	182
2.2	Categorization of stakeholders .....	183
<b>3</b>	<b>Detailed analysis of selected stakeholders.....</b>	<b>184</b>
3.1	An analysis of selected stakeholders.....	184
3.2	Analysis of stakeholder engagement progress .....	185
<b>4</b>	<b>Stakeholders' roles in SSC.....</b>	<b>187</b>
4.1	Municipalities, city council and city administration.....	187
4.2	National and regional governments.....	190
4.3	City services companies.....	191
4.4	Utility providers .....	192
4.5	ICT companies (e.g., telecom operators, start-ups, software companies) ....	192
4.6	Non – governmental organizations (NGOs) .....	193
4.7	International, regional and multilateral organizations .....	193
4.8	Industry associations .....	194
4.9	Academia, research organizations and specialized bodies .....	195
4.10	Citizens and citizen organizations .....	196
4.11	Urban planners .....	196
4.12	Standards Developing Organizations (SDOs) .....	197
<b>5</b>	<b>Conclusions .....</b>	<b>197</b>
	<b>Annex 1 – Summary of Stakeholder Identification, categorization and analysis .....</b>	<b>199</b>
	<b>Annex 2 – SCC – CERT/CSIRT/SOC.....</b>	<b>205</b>
	<b>Bibliography .....</b>	<b>209</b>





Think

Design

IDEAS

Creative





## Setting the stage for stakeholders' engagement in smart sustainable cities

### Executive summary

This Technical Report has been developed as part of the mandate of the International Telecommunication Union's (ITU) Focus Group on Smart Sustainable Cities (FG-SSC). It responds to the need for identifying and mapping the different stakeholders that are involved in the development of Smart Sustainable Cities (SSC), to foster broad cross-sectoral engagement and participation in SSC strategies.

In addition to identifying the key stakeholders' roles and responsibilities within SSC, the report aims at providing a series of recommendations to ensure the effective integration of these stakeholders in the design, implementation and assessment of SSC operations.

This report argues that, despite the potential of SSC to overcome the challenges posed by rapid urbanization and heightened vulnerability due to stressors such as climate change, SSC also face operational, financial, technological and human resource challenges, including the effective engagement and participation of citizens since the inception of SSC strategies.

The analysis suggests that, in order to overcome these aforementioned challenges and take advantage of potential opportunities, SSC decision makers need to effectively integrate multiple key stakeholders in the process of transformation of their cities into smart sustainable cities.

In order to facilitate this integration the report suggests a methodology to identify and map key stakeholders, based on the principles of the Logical Framework Approach (LFA). Building on that, the analysis identifies the role and responsibilities of each of the stakeholders involved in the effective functioning of SSCs, including municipalities and city administration, national and regional governments, city services companies and utility providers, ICT companies, NGOs, multilateral organizations, industry associations, urban planners, academia, scientific community and research organizations, citizens and citizen organizations, and standardization bodies.

This Technical Report indicates that, in order to foster an inclusive approach, city decision makers should take into account the diversity of stakeholders supporting the development of a SSC initiative or project. This report describes three steps to accomplish this: (1) developing an initial stakeholder identification process; (2) categorizing and identifying the relationships among them, and (3) conducting a detailed analysis of all stakeholders' interests to identify their role and contribution to the SSC.

The document concludes with general recommendations on SSC stakeholder integration, by presenting a summary table identifying SSC stakeholders, their scale/sector of operations, their key aims and challenges, strengths and constraints associated with their role, and their expected contribution to the SSC's rollout.



## Introduction

In the last 50 years, the world's population has grown exponentially at an average rate of 1.2% per year. Globally, more people live in urban areas than in rural areas. In 2007, for the first time in history, the global urban population exceeded the global rural population, and the world population has remained predominantly urban thereafter.<sup>1</sup> As of 2014, 54 % of the world's population resides in urban environments and by 2050, 66 % of the world's population is projected to be urban.<sup>2</sup> This rapid urbanization is adding pressure to cities, with increasing demand for energy, water, sanitation, as well as for public services, education and health care.

Strategies to implement Smart Sustainable Cities (SSC) are emerging around the globe as a response to the challenges posed by this rapid urbanisation, by integrating Information Communication Technologies (ICTs) into all aspects of the city's planning and operation. Acting as a platform, ICT tools enable information gathering to increase the efficiency of the city's functions, allowing both the municipality and the citizens to make better informed decisions, facilitating the integration of city services, and the cooperation across different sectors.

The Focus Group on Smart Sustainable Cities (FG-SSC) of the International Telecommunication Union (ITU) brings together a variety of SSC stakeholders (e.g. municipalities, academic and research institutes, non-governmental organizations (NGOs), ICT organizations, industry forums and consortia) with the interest of identifying the standardized frameworks needed to support the integration of ICT services in smart sustainable cities. Smart sustainable cities bring together a variety of stakeholders. This is one of the key prerequisites for the success of SSC: the effective integration of private, governmental and public bodies, the citizens, and also the academic and scientific communities. This concurrence of actors also results in high complexity, evidencing the need for an in-depth analysis of the stakeholders involved in the design and implementation of SSC strategies. This includes the design of a comprehensive map of actors involved in this new urban landscape, including their potential role and contribution to the realization of SSC, defined by the ITU-T Study Group 5 and UNECE as follows:

*"A smart sustainable city is an innovative city that uses information and communication technologies (ICTs) and other means to improve quality of life, efficiency of urban operation and services, and competitiveness, while ensuring that it meets the needs of present and future generations with respect to economic, social, environmental as well as cultural aspects."<sup>3</sup>*

This report is divided into four sections. The first section presents an overview of the main challenges faced by SSCs, including operational, financial and technological aspects, as well as human resource and citizen engagement. The report argues that, in order to overcome these challenges and take advantage of potential opportunities, SSC strategists need to integrate the role of multiple key stakeholders. The second section proposes a methodology for the identification of stakeholders, based on the principles of the Logical Framework Approach (LFA).<sup>4</sup>

<sup>1</sup> [http://www.un.org/en/development/desa/policy/wess/wess\\_current/wess2013/WESS2013.pdf](http://www.un.org/en/development/desa/policy/wess/wess_current/wess2013/WESS2013.pdf)

<sup>2</sup> <http://esa.un.org/unpd/wup/Highlights/WUP2014-Highlights.pdf>

<sup>3</sup> <http://www.itu.int/en/ITU-T/focusgroups/ssc/Pages/default.aspx>

<sup>4</sup> Introduction to the Logical Framework Approach (LFA) for GEF-financed projects. German Foundation for International Development.

Building on that, the third section provides an in-depth analysis of the roles and responsibilities of each of the stakeholders that contribute to the effective functioning of SSC, namely municipalities and city administration, national and regional governments, city services companies and utility providers, ICT companies, NGOs, multilateral organizations, industry associations, academia and scientific community, citizens and citizen organizations, and standardization bodies.

The final section of the report outlines a series of strategic recommendations for multi-stakeholder involvement, aimed at city decision makers working in the design and/or implementation of SSC.

The report concludes by presenting a summary table that identifies SSC stakeholders, their scale/sector of operations, their key aims and challenges, their potential and constraints associated with their role, and their expected contribution to SSC's rollout.

## Scope

The FG-SSC Working Group 1 (WG1) suggests that one of the major challenges in the emerging SSC field is the lack of a common framework and understanding of SSC stakeholders, including their roles and responsibilities. Responding to that need, the objective of this report is to strengthen the design and implementation of SSC by providing all interested stakeholders with a clear overview of roles and responsibilities, including a series of recommendations that can help maximize their contributions to SSC goals.

Global human security and development depend on the strengthening of collective action. The many challenges faced (including the establishment process of SSC) cannot be met effectively by individual governments without the active involvement of civil society, non-governmental organizations (NGOs), private sector.<sup>5</sup>

Hence, countries, governments, business and various stakeholders realize that complex issues such as the establishment of SSC cannot be achieved by a single actor. Such complex activities would require coordinated effort with multiple stakeholders contributing to innovative and sustainable solutions.<sup>6</sup> This document based on this fact is expected to help maximize the contribution of each of these actors, prevent overlapping of functions, and facilitate the identification of gaps, so as to increase the likelihood that SSC's goals will be achieved.

It is expected that this document will help to maximize the contribution of each of these actors, prevent overlapping of functions, and facilitate the identification of gaps, so as to facilitate the achievement of SSC's goals.

This report is addressed to a broad audience of city decision makers and practitioners involved in the design and implementation of SSC. It is intended to be as general and inclusive as possible, applicable and relevant to any city, regardless of its size or location, in both developed and developing countries. The concepts and definitions presented in this document are in alignment with the series of Technical Reports on smart sustainable cities produced as part of the deliverables of ITU's FG-SSC.

---

<sup>5</sup> UN System Engagement with NGOs, Civil Society, the Private Sector and other Actors. United Nations Non Governmental Liaison Service, German Federal Ministry For Economic Cooperation

<sup>6</sup> The Stakeholder Engagement Manual Volume 1: The Guide to Practitioners Perspectives on Stakeholder Engagement Volume 1

# 1 *Smart sustainable cities: overview and challenges*

---

The first part of this section provides a brief summary of the work undertaken by the three working groups that form the FG-SSC, in order to highlight the importance of adopting a multi-stakeholder approach in the emerging SSC field. The second part of the section identifies the key challenges faced by SSC and its stakeholders.

## 1.1 **SSC overview**

FG-SSC Working Group 1 has developed a general overview and a standardized definition for smart sustainable cities, as indicated above. Studies conducted by the group experts suggest the existence of a series of attributes that are crucial to better understand the nature and impact of SSC, including those related to goals of sustainability, quality of life, efficient provision of urban services, as well as intelligence or 'smartness.'<sup>7</sup>

In addition to those key attributes, WG1 suggests that the following are the key themes that lie at the core of SSC operations:

- Society – the city is for its inhabitants (the citizens).
- Economy – the city must be able to thrive – in terms of jobs, growth, finance.
- Environment – the city must be sustainable in its functioning for future generations.
- Governance – the city must be robust in its ability to administer policies and put together the different elements.

Building on these foundations, the FG-SSC Working Group 2 has developed a series of Technical Reports that explore the use of ICT in smart sustainable cities. From this series, the report on SSC Infrastructure suggests that the architecture of SSC is composed of different layers (i.e., sensing layer, communication layer, data layer and application layer). These layers relate ICT infrastructure to cities, and are a useful reminder of the complexity that characterizes SSC. It suggests that the successful operation of these cities requires an intricate articulation of multiple fields of expertise and sectoral engagement. This complexity also illustrates the need for an inclusive, multi-stakeholder approach in the design and implementation of SSC infrastructure and several ICT services for smart buildings, for climate change adaptation, and for smart water management, among others.

Also reflecting the need for this approach, the FG-SSC Working Group 3 has developed a series of reports aimed at developing a standard set of Key Performance Indicators (KPIs) for SSC evaluation. WG3 has identified multiple dimensions to assess and measure the performance and impact of SSC (i.e., indicators related to ICT infrastructure, environmental sustainability, productivity, quality of life, equity and social inclusion, and non-ICT infrastructure development) which reflect the wide range of perspectives that need to be considered in SSC.

The next part of the section identifies some of the key challenges faced by SSC. Exploring these areas is crucial to gain a more in depth understanding of the potential contribution of different stakeholders to overcome existing and emerging constraints, and achieving the full potential of SSC.

---

<sup>7</sup> [LINK TO OVERVIEW DOCUMENT-WG1.](#)

## 1.2 SSC challenges

The work developed by the different working groups of the FG-SSC has brought to light several challenges faced that cities need to address as part of the design and implementation of SSC strategies in a complex multi-stakeholder urban environment.

Some of the most likely challenges which SSC stakeholders could possibly face are the following:

- **City vision challenges**

There are various paths to becoming a SSC: each city has its own needs, and starts from a different baseline. In this sense, standards are needed to create a common framework that can continuously support and foster sustainable development as well as allow comparability and evaluation of results for different cities and initiatives. The standards used in SSC would define any necessary baselines and quantify improvements progressively. They would also become the foundations which cities across the globe could develop upon based on their cities' priorities and capacity. This is particularly important in smart sustainable cities as sustainable development policies often involve multiple stakeholders at all levels of government.

The process of becoming a SSC is not a short one, and is a forward looking commitment to be fulfilled in a long-term future. To achieve the successful completion of a long term SSC roadmap it is important that all political parties of the municipality are involved in the definition of the strategy and remain committed to the project.

Finally, the approach to SSC must be holistic and inclusive. This is not easy to achieve because, traditionally, city management is divided into different departments with little cooperation between them. Therefore, it is crucial to increase interdepartmental communication and cooperation. The same issue applies at the national level, where the management could be divided into different ministries or departments. Achieving communication and cooperation at all levels of government is of paramount importance as building the city's a common vision is not restricted to one level only, but it requires a combined effort from at all levels of government.

- **Economic and financial challenges**

The lack of funding for city projects has become a common obstacle in the development of SSC. In the case of developed countries, the recent global and regional economic recession has severely restrained limited their capacity in investing in SSC initiatives. The recession between 2008 and 2012 has "reduced capital accumulation for new investments... these, in turn, affect the pace of innovation and the general development of the green economy... in the U.S. investments in clean technology dropped from 1 billion to 154 million... venture capital investment in clean technology also dropped from 991 million to 791 million."<sup>8</sup> In the case of developing countries, limited resources and widespread poverty simply mean that while these countries do invest in sustainable development initiatives, other areas which require immediate attention become their priorities. With 1.2 billion people still living on less than a dollar a day, and half of the developing world still lacking access to sanitation<sup>9</sup>, it is not surprising that investment on a common SSC framework or SSC services may not be a priority item in the development agenda. Additionally, there are difficulties in accessing resources from financial institutions due to the lack of business models that determine the return of the investment.

---

<sup>8</sup> [http://tokyo2013.earthsystemgovernance.org/wp-content/uploads/2013/01/0177-OBANI\\_GUPTA.pdf](http://tokyo2013.earthsystemgovernance.org/wp-content/uploads/2013/01/0177-OBANI_GUPTA.pdf)

<sup>9</sup> <http://www.grida.no/publications/et/ep4/page/2632.aspx>

Considering that citizens' welfare is a priority of any SSC, job creation and maintenance must be rallied as the cornerstone during the developmental stage of SSC. Hence, an important challenge for SSC stakeholders at all levels is to take advantage of the projects and transformations the city will go through to generate employment and promote the creation of new businesses, so that the city's economy can benefit from this transformation. In other words, a multi-stakeholder approach is crucial as a variety of stakeholders working together can not only contribute to the transformation of the city towards becoming smart and sustainable but also in getting through tackling challenges more easily and more effectively.

#### ▪ **Technological challenges**

While the number of mobile-broadband subscriptions has reached 2.3 million with 55% of them in developing countries,<sup>10</sup> most SSC solutions require the support of ICT infrastructure and services that many cities still lack. This includes widespread Internet broadband, comprehensive mobile network or communication networks for sensors, among others. The deployment of such infrastructure constitutes a major challenge that needs to be overcome. This problem is particularly acute in developing countries where the existing infrastructure is inadequate and connectivity rates remain low, a situation often referred to as the 'digital gap'.

When planning the deployment or the upgrading of ICT technology, it is important to consider the adaptability, scalability, accessibility, safety and flexibility of this infrastructure. Incorporation of technology with the current infrastructure is also a very important issue to be addressed.

Another challenge in this category is the lack of accessibility to information about the technology. This is partly attributed to the novelty of this field and also because companies are protective about their technological knowhow. Collaboration and sharing of know-how could be very beneficial in improving access. For instance, information about the specific technology used in the initiatives that are being carried out in different cities could be of use to others who may want to replicate their actions. It is evident that information sharing is important to ensure success for smart sustainable cities. Stakeholders working together and sharing information will lead to better decision making in the long run.

#### ▪ **Low levels of citizen engagement and participation**

Citizens' participation in the development of municipal projects is critical for urban development. As core users of city services, it is important that city planning strategies include the vision and expectations of the citizenry. ICT technologies such as mobile applications or social media tools can be very helpful to enable citizen engagement and participation. According to the Eurocities Initiatives Report "Citizen participation: paving the path to new city politics", citizens' participation improves city management, promotes social cohesion and reinforces political engagement. The integration of the perspective and opinions of city residents into local policies can support the adaptation of city services to their daily needs.<sup>11</sup>

#### ▪ **Scarcity of natural resources**

Cities are facing serious environmental challenges related to issues such as energy, water, air quality, sanitation, waste management and other city management activities. According to the KPMG report "Expect the Unexpected: Building business value in a changing world", cities will require extensive improvements in infrastructure including basic city services to manage efficiently

---

<sup>10</sup> <http://www.itu.int/en/ITU-D/Statistics/Documents/facts/ICTFactsFigures2014-e.pdf>

<sup>11</sup> [http://www.eurocities2012.eu/fichier/p\\_ressource/4548/ressource\\_fichier\\_en\\_citizen.participation.eurocities.2012.nantes.pdf.pdf](http://www.eurocities2012.eu/fichier/p_ressource/4548/ressource_fichier_en_citizen.participation.eurocities.2012.nantes.pdf.pdf)

scarce resources in cities.<sup>12</sup> This resource constraint has brought into focus the need to be more sustainable in all aspects of human living and has been precisely one of the triggers of the transformation to SSC. Rising energy prices, energy security, depleting energy sources and global warming caused due to the impact of energy usage have made energy management one of the key challenges to smart and sustainable cities.

Cities stakeholders demand different type of resources; therefore it is important that decision makers and citizens should understand that resources are limited. In this respect, ICT can play a crucial role in developing services for the efficient management of waste, water and energy in cities, for example with smart buildings, smart water management systems and smart grid technologies.

#### ▪ **Environmental management challenges**

Cities face several environmental management challenges due to its economic activities, urban expansion patterns and citizens' consumption habits. At present cities are responsible for the management of the environmental quality of the city (air, soil and water) and its pollution control. Cities must provide services such as urban waste management or transportation. With increasing urbanization, cities are enduring various challenges to secure financially sustainable water and sanitation services for its citizens.<sup>13</sup>

The growing demand of goods and services in cities, generate an ecosystem in which economic and industrial activities are carried out. If not controlled effectively, these generate environmental risks especially with reference to potential pollution sources such chemicals, hazardous waste generation, emissions, among others. Controlling and managing these environmental problems is the responsibility of city administration. In this context, any process or solutions that can be improved by ICT based smart sustainable cities solutions should be considered to improve a city's environmental quality.

#### ▪ **Climate change challenges**

The role of cities has been increasingly recognized as being key in the implementation of policies and programs to tackle climate change impacts. In the future cities may need to become much more resource efficient and resilient in the face of extreme weather events and other threats. As experts have pointed out, "natural hazards linked to climate change have increased in intensity and frequency... rising sea level, floods, heat waves, and storms are projected to continue to be worsen."<sup>14</sup> Scientists project that the adverse effects may include more floods, windstorms, forest fires, and the melting of permafrost that holds about 1,700 gigatons of carbon.<sup>15</sup> At present, most of the cities of the world are called upon to develop their climate actions plans with a long-term planning vision. These plans usually include mitigation and adaptation policies together with an innovative approach to technologies and financing mechanisms.<sup>16</sup>

---

<sup>12</sup> [https://www.kpmg.com/dutchcaribbean/en/Documents/KPMG%20Expect\\_the\\_Unexpected\\_ExtveSmmry\\_FINAL\\_WebAccessible.pdf](https://www.kpmg.com/dutchcaribbean/en/Documents/KPMG%20Expect_the_Unexpected_ExtveSmmry_FINAL_WebAccessible.pdf)

<sup>13</sup> Technical Report on Smart Water Management for Smart Sustainable Cities. Focus Group on Smart Water Management (FG-SWM). International Telecommunications Union (ITU).

<sup>14</sup> <http://sustainabledevelopment.un.org/content/documents/2843WESS2013.pdf>

<sup>15</sup> <http://www.worldbank.org/en/news/speech/2014/01/15/climate-change-is-challenge-for-sustainable-development>

<sup>16</sup> World Bank. Cities & Climate Change Leadership Program. (2013)



Given that land use, buildings, electricity production, industrial energy use, transport, or waste management generate over 90% of GHG emissions sources in cities.<sup>17</sup> Cities face climate change mitigation challenges, particularly to minimize emissions or to optimize services that produce GHG emissions on a local level. At present, existing technologies for climate change mitigation in cities still require major technological shifts, new investments and integrated planning.

From a climate adaptation point of view, cities are the territorial areas of the planet that are the most vulnerable to the impacts of climate change. These specific impacts differ among countries, regions and cities, and can vary from an increase in extreme weather events and flooding, to hotter temperatures in particular locations, negatively affecting social welfare in cities. Floods for example, are impacting major industrial activities or are exacerbating the conditions of poverty for inhabitants of vulnerable areas.<sup>18</sup>

At the same time cities face challenges in implementing climate change mitigation and adaptation policies. However, these challenges can turn into opportunities as cities provide the optimal scenario to lead and foster the use of ICTs for climate change mitigation and adaptation. In this respect, cities will need to invest today to reduce costs to adapt and transform their infrastructure in the future in order to be able to optimize city services. Cities need low-carbon services. Smart technologies supported by ICTs can help achieve these goals (e.g. smart building or smart transport solutions). From an adaptation point of view, the role of ICT infrastructure and services are critical for climate adaptation planning, as well as for the implementation of disaster risk management programs.

Cities that are in the process of becoming smart and sustainable, have a huge opportunity to include in their climate change actions plans, ICT infrastructure and ICT solutions to improve efficiency of their city services. As the intensity of urbanization is expected to increase, most of the urban infrastructure that will exist in 40–50 years has not yet been built. Therefore cities are called on to plan a long term strategy with ICTs in mind that may avoid locking themselves in costly, high-emitting and non-climate resilient infrastructures.

- **Shortage of SSC expertise**

In order to succeed in the implementation of smarter and more sustainable cities, expert professionals in this specific field are needed. This refers to urban planners, technologists, economists, among other types of professionals, who must be prepared to deal with the challenges of the new urban landscape. Apart from being experts on their specific field they should have a general awareness of all the other aspects that define and shape cities. More importantly, this transversal knowledge has to enable them to have a holistic and integrated view of the SSC framework. In this scenario, an urban planner or an environmental expert would also have general knowledge about the capabilities and functioning of the Internet of Things (IoT) applied to cities, and the ICT infrastructure that is needed for that and can therefore have a holistic vision of the SSC.

- **Growing inequality**

The World Economic Forum on its Outlook on the Global Agenda 2014<sup>19</sup>, ranked widening income disparities as the second most significant global trend. A recent study by Oxfam suggest that "seven out of ten people live in countries where economic inequality has increased in the last 30 years" and

---

<sup>17</sup> <http://www.epa.gov/climatechange/ghgemissions/global.html>

<sup>18</sup> Guide to Climate Change Adaptation in Cities. World Bank. (2011)

<sup>19</sup> <http://www.weforum.org/reports/outlook-global-agenda-2014>

"almost half of the world's wealth is now owned by just one per cent of the population."<sup>20</sup> Since SSC strive for social sustainability is therefore important that the projects developed include all the levels of society.

The range and nature of the multiple challenges that are faced by SSC evidence the need to gain a more in-depth understanding of the stakeholders that play a role in the operation of SSC, that can help overcome obstacles and take advantage of opportunities towards the realization of smart and sustainable city goals.

Having explored the different challenges that cities face, it is important to realize the multi-stakeholder nature of SSC. Accordingly, the next section will propose a methodology to facilitate the identification of these stakeholders, as well as their inclusion into SSC strategies.

## 2 Methodology for SSC stakeholder identification and engagement

---

In this report a stakeholder is defined as any entity, an institution or an individual, that has an interest in smart sustainable cities. A stakeholder may also be an entity/institution/individual that can significantly influence or be influenced by its deployment.<sup>21</sup>

Stakeholder engagement may be viewed as a technique of enhancing the (i) relevance, (ii) responsiveness (iii) accountability (iv) transparency (v) inclusiveness (vi) legitimacy (vii) effectiveness (viii) efficiency (ix) equitability of the decision making process. Keeping in mind the aforementioned aspects, if the stakeholder identification and participation are carried out properly, good participation can itself make a significant contribution to the governance. This is based on the assumption that policymaking conducted in an interactive way would build on stakeholder knowledge and this process of policy making would be more contextual, reliable and easy to implement.<sup>22</sup> Based on this, the methodology for stakeholder analysis for SSC has been elaborated in this Technical Report.

The methodology for stakeholder analysis that has been followed in this report is an adaptation of the principles proposed by the Logical Framework Approach (LFA).<sup>23</sup> The methodological approach proposed is general in scope, and aims at obtaining a broad classification of the stakeholders involved in a city that wants to become smart and sustainable. This method can be adapted by a particular city to identify and analyse the stakeholders that play a role at the local level.

The steps proposed are summarized in Figure 1 and further developed during this chapter.

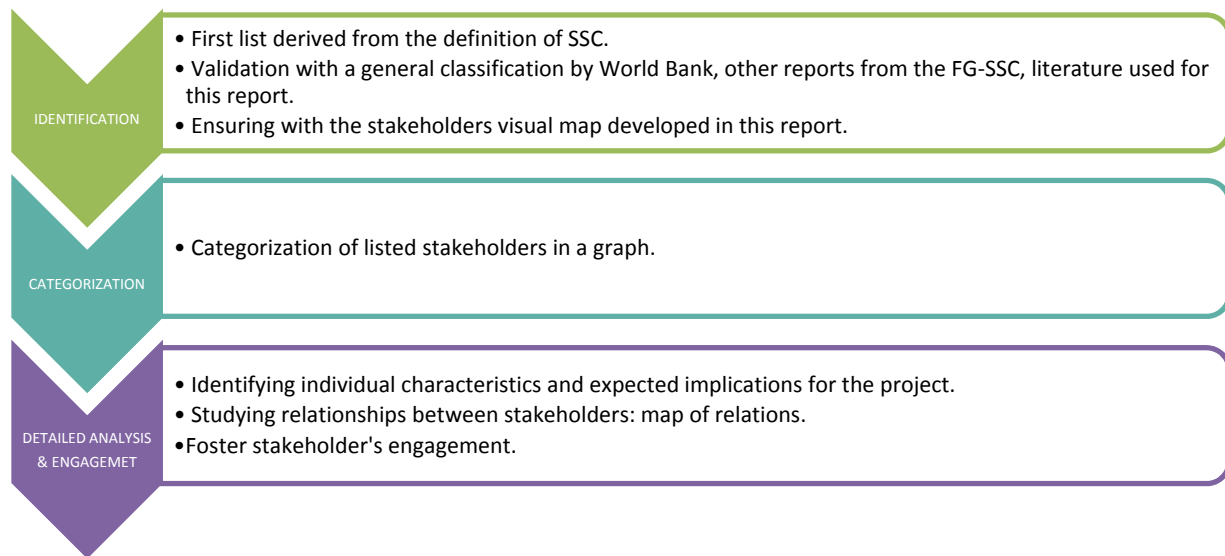
---

<sup>20</sup> Working for the few. Oxfam 2014. <http://www.oxfam.org/sites/www.oxfam.org/files/bp-working-for-few-political-capture-economic-inequality-200114-en.pdf>

<sup>21</sup> The definition is a modification from the definition that appears in <http://www1.worldbank.org/publicsector/anticorrupt/PoliticalEconomy/stakeholderanalysis.htm>

<sup>22</sup> Strengthening UNEP's Legitimacy: Towards Greater Stakeholder Engagement. United Nations Environment Programme

<sup>23</sup> Introduction to the Logical Framework Approach (LFA) for GEF-financed projects. German Foundation for International Development.



**Figure 1 – Steps involved in the analysis of SSC stakeholders**

Adapted from World Bank and LFA approach.

## 2.1 Identification of all stakeholders involved in SSC

In this first stage, all stakeholders which may be affected or which can affect the deployment of the SSC model are identified. The following steps were carried out in order to compile the list of key SSC stakeholders:

- Initial list derived from the definition: agents that are interested, affected or that have power to influence SSC.
- Validation of the list based on a general classification of stakeholders.
- Validation of the list with stakeholders that appear on the different reports from the FG-SSC.
- Validation of the list with stakeholders that appear on the literature used for this report.

Based on those steps, the following non-exhaustive list of SSC stakeholders has been compiled (in no particular order):

- a. **Municipalities, City Council and city administration:** They are responsible for city management, and therefore they are the main promoters of SSC initiatives on each specific city.
- b. **National and regional governments:** They have remit on policies that can affect SSC implementation.
- c. **City services companies:** Would be implementing SSC solutions to increase city services efficiency.
- d. **Utility providers:** They are responsible for the deployment of some of the features of SSC such as smart grid or smart water management.
- e. **ICT Companies (Telecom Operators, Start-ups, Software Companies):** Are the providers of the global and integrated solutions, the city platforms, as well as the ICT infrastructure to support SSC deployment.
- f. **NGOs:** These are involved in all initiatives that can influence society and therefore are considered a stakeholder in SSC, especially on the axis of social sustainability.

- g. **International, Regional and Multilateral Organizations:** They include UN agencies and multilateral organizations. They can be promoters of initiatives towards human development, environmental sustainability and improvement of quality of life worldwide. They can offer funding opportunities, and are promoters of SSC initiatives.
- h. **Industry associations:** Since industries are interested in the deployment of SSC, industry associations also work towards the success of this new model.
- i. **Academia, research organizations and specialized bodies:** They study SSC and associated trends, including its impacts and contributions to sustainable development.
- j. **Citizens and citizen organizations:** As inhabitants of cities, citizens are affected both directly and indirectly by SSC deployment.
- k. **Urban Planners:** Their expertise is important to better understand how to include ICTs into medium and long term city planning, as well as to consider urban complexities.
- l. **Standardization bodies:** These organizations are critical to ensure a common terminology and minimum characteristics of a SSC, as well as to define measurement methods to assess the performance and sustainability of city services based on ICT technologies.

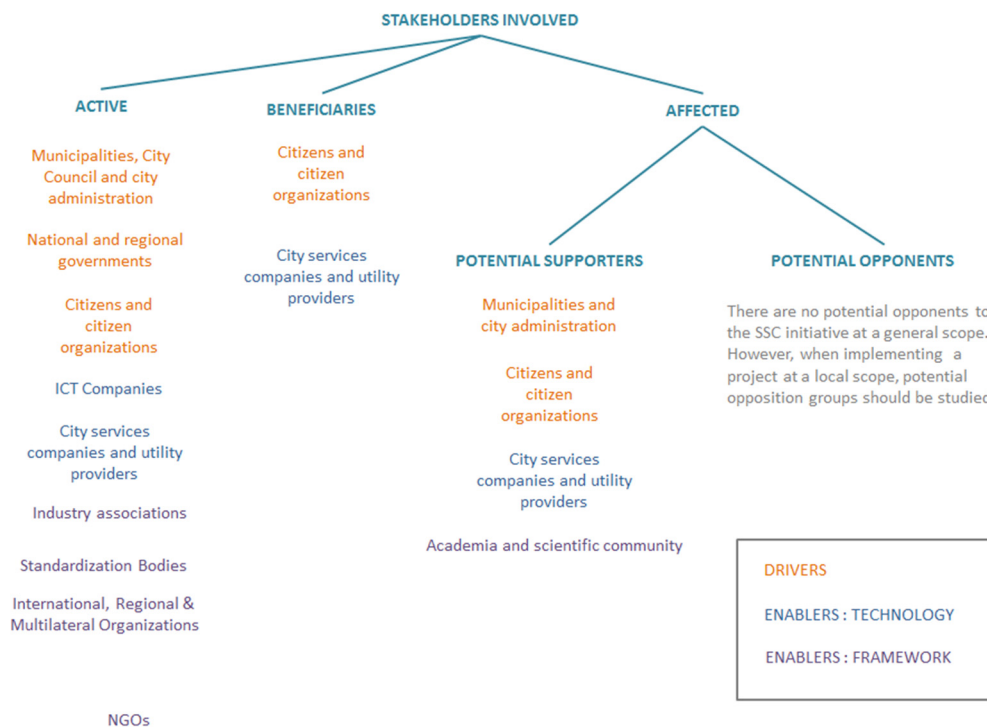
The roles and responsibilities of each of these stakeholders will be further explained in section 4.

## 2.2 Categorization of stakeholders

The stakeholders included in the list are then categorized according to two different criteria:

- a) According to their **role and participation in a project or projects related to SSC**. This classification is based on the LFA methodology, as follows:
  - **Active:** This refers to all the actors that have the resources and the power to influence the initiative. In this report all stakeholders have been classified as active because potentially any of them can influence the SSC agenda. When making this classification at the local level this list is usually shorter since not all the actors who potentially could, will have the resources and power to do so.
  - **Beneficiaries:** These are the stakeholders that will directly benefit from the deployment of SSC.
  - **Affected:** This category includes all actors that will be somehow affected by the deployment of SSC. They can be further divided in potential supporters, and potential opponents.
- b) According to their role as drivers or enablers of SSC processes and solutions.
  - **Enablers of technology:** They provide the technology and/or the technological solutions.
  - **Drivers of technology:** These are the stakeholders that incorporate technology and SSC solutions into their processes, for example in city services provision processes.
  - **Enablers of the SSC:** They facilitate the technical & policy framework needed for SSC by collaborating to some extent into concepts and KPIs definition, infrastructure development, standardization, etc.

Figure 2 illustrates a classification of SSC stakeholders at a general level, based on the categories explained above. It is relevant to note that, given the specific context and set of stakeholders that operate in a particular city, the implementation of this method will slightly differ from one city to another.



**Figure 2 – Example of SSC stakeholder classification.**

Adapted from the LFA Methodology.

This stakeholder mapping exercise will provide cities with an initial framework to identify the stakeholders that will take part of their transformation into smart sustainable cities. It is intended to be a tool to facilitate the coordination activities needed to implement SSC policies and projects. As mentioned before, the stakeholder identification has to be city-specific.

### 3 Detailed analysis of selected stakeholders

#### 3.1 An analysis of selected stakeholders

This is one of the most important phases of the stakeholder's identification process for SSC, because it establishes a methodological approach to analyse the role and potential contribution implications that one stakeholder may have on a city. This analysis can be done considering two approaches, described as follows:

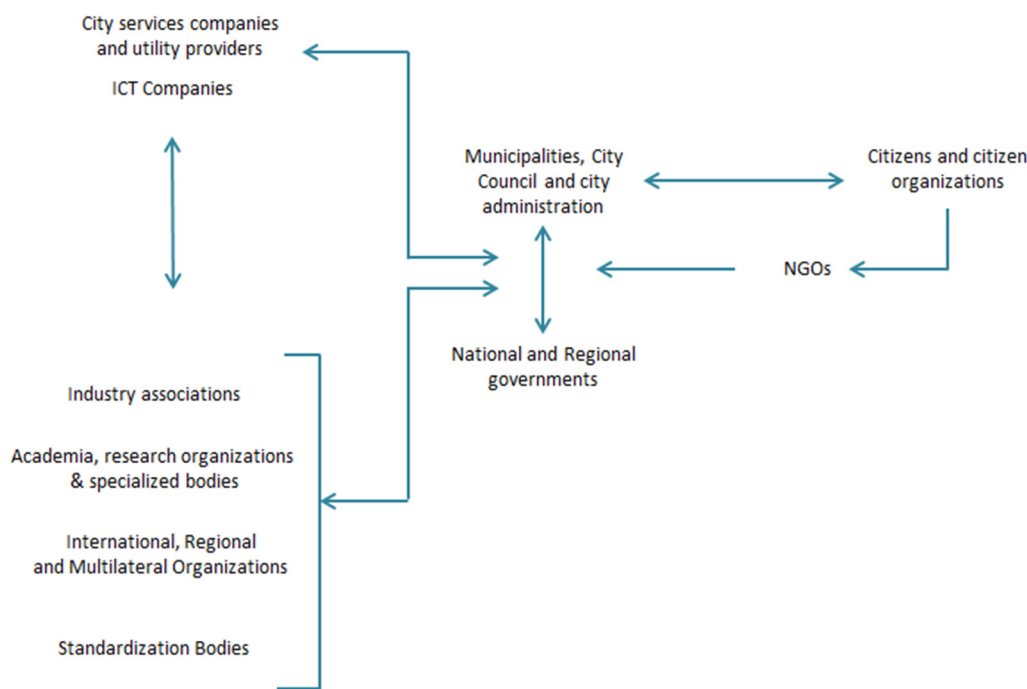
- a. By identifying their individual characteristics and their potential contribution expected implications for the project, which can be illustrated in a matrix of stakeholders containing the following dimensions:
  - **Scale and Sector:** The scale at which the stakeholder operates (e.g., local or supra-local scale); and, when relevant, the sector in which they operate (e.g., public or private sector).
  - **Aims and Challenges:** The aims refer to the key objectives or advantages they seek from their involvement in SSC strategies, while challenges refer to the problems, unsatisfied needs or concerns they might have.
  - **Potential and Constraints:** Potential refer to issues such as stakeholders' resource endowment, knowledge, experience and know-how. Constraints refer to issues that

limit the realization of their role within SSC, including lack of coordination, lack of expertise, limited financial resources, among others.

- **Role and Contributions:** This refers to the role of the stakeholder with respect to SSC's goals, and the contributions towards their achievement.

A summary table that illustrates this classification has been included as part of the reports' conclusions in Annex 1.

- b. The graph below provides an overview of the stakeholders involved in SSCs, and how they relate with each other.



**Figure 3 – Example of SSC stakeholder's (interaction) map**

Both analyses should be developed together in order to better understand stakeholders roles and relationships. The next section of this report provides an analysis of these dimensions per SSC stakeholder.

### 3.2 Analysis of stakeholder engagement progress

After selection of the potential stakeholders for SSC, it is essential that the engagement progress is also mapped carefully to avoid pitfalls. Perils that may impede SSC progress may include the following:

- As the identified stakeholder reflect various power structures within a city, some of the stakeholders may wield more power (monetary as well as administrative) than others. For example. The business and industry group tend to more well-funded and influential and may overpower the influence of other groups and prioritize their own interests. Care needs to be taken to maintain a balance between competing interests.
- Potential SSC stakeholder engagement comes at a price - the process described in this report of SSC stakeholder engagement could become bureaucratic, labour intensive and may never be perfect or completely inclusive. As such care need to be



taken to ensure that the process may needs to be reviewed, updated and monitored continuously.

- Stakeholder process may even become “exclusive” and privileged groups and the large number of social segments and rights holders who are organized within a formalized group may be excluded from the process of SSC establishments.<sup>24</sup>

To promote effective stakeholder engagement, there are common guiding principles for effective stakeholder engagement that facilitate this process:

- The consultative process should recognize diversity of stakeholder and must include a wide range of relevant stakeholders at national, sub-national and local levels.
- These consultations must be conducted with transparency in mind along with timely access to required information. The relevant stakeholders should have prior access to the information before the consultative process starts.
- Consultations should be conducted with the aim of building consensus and should facilitate dialogue and exchange of information.
- Impartial, accessible and fair mechanisms for grievance, conflict resolution must be established before the consultative process.<sup>25</sup>

### 3.2.1 Core values of stakeholder participation

Given the apparent pitfalls of the stakeholder engagement progress, it also is essential to outline the core values of principles to be followed during stakeholder participation. These core values include:

- All the identified stakeholders should be allowed to a stand on all decisions about SSC based actions that could affect the life of the inhabitants.
- The contribution of each stakeholder will in principle be heard and will influence the final decision.
- Stakeholder participation should include communication and recognizing the needs and interests of all participants including the decision makers themselves.
- Stakeholder participation would provide the participants with the required information needed to contribute to the policymaking process in a meaningful way.
- Stakeholder participation seeks out and facilitates the involvement of actors either likely to be affected by the decision making process or those actors interested in contributing to the process.
- Stakeholder participation would also include communicating to the participant how their input affected the final decision making process.<sup>26</sup>

---

<sup>24</sup> Strengthening UNEP’s Legitimacy: Towards Greater Stakeholder Engagement. United Nations Environment Programme.

<sup>25</sup> Guidelines on Stakeholder Engagement in REDD+Readiness with a Focus on the Participation of the Indigenous People and Other Forest Dependent Communities.

<sup>26</sup> Stakeholder Engagement: A Road Map tp Meaningful Engagement: How to do Corporate Responsibility Series.

## 4 Stakeholders' roles in SSC

---

This section explores in further detail each of the SSC stakeholders, including a brief definition of, and an outline of the roles they are meant to take.

### 4.1 Municipalities, city council and city administration

Municipalities are the basis for SSC management, and are at the core of the SSC framework. Municipalities and its departments must be the body that coordinate all the system within an integrated technological platform. Municipalities are constantly involved in development strategies and will hence play a pivotal role in SSC initiatives. They would also serve as a convenient contact point for the inhabitants regarding SSC establishment.

Municipalities have to deal with the everyday problems and demands of citizens and the challenges of city management. Shrinking municipal budgets on one side, and the need to reach national and international targets of reduction of emissions on the other, are pushing municipalities to become more sustainable, both environmentally and economically. Additionally, the growing demand of the voters for transparency and citizen participation in municipal issues triggers the development of more socially sustainable cities.

As the main promoters on the idea of becoming a SSC<sup>27</sup>, municipalities have the responsibility to decide which path to follow, from the long-term roadmap to the specific solutions to implement. There is not a unique path, so each city can choose theirs depending on the qualities of the city, its state of affairs, strengths and opportunities available. It is important that they do so thinking on the long run, with a holistic approach, transparency and the citizen interests at its core.

One way to increase efficiency in city services is to evaluate them through objective indicators agreed between the municipality and the service provider. To achieve this there has to be a change from the tendering model that is currently based on assets to a model based on Key Performance Indicators (KPIs). As the main consumers of solutions, municipalities are ideally placed to lead this change to KPIs-based public tender offers. For the model to work, municipalities should act as the examiner on the performance of the services, starting by choosing what KPIs will apply, what values have to be achieved and under what conditions and continuing with periodical evaluations. Otherwise, the city service companies would be acting as judge and judged on their own evaluation.

Another important responsibility this stakeholder has is to engage public participation and include the citizen on any SSC initiative. As it will be seen later, citizen engagement is pertinent to many urban projects and even more importantly, the final objective of SSC is to enhance the satisfaction and the quality of life of the citizenry. Most SSC projects entail benefits for the population at several levels, but often these benefits are not perceived by the citizens. Consequently, it is recommended that municipalities conduct efforts to communicate the decisions taken, as well as the advantages and consequences these entail.

Regarding public participation, the city administration has to ensure that all the population is informed and has the means needed to take part on the programs and initiatives being carried out.

Another important aspect in this area is the accessibility to public data by the citizenry. An "Open Data" platform where the citizen can access all public data, except confidential or critical, is

---

<sup>27</sup> Informe Anual Smart Cities Telefonica.

primordial in any SSC to ensure transparency and will also act as a catalyser for innovation and business generation.

One of the keys for the success of SSC strategies is that they must have a holistic vision, so all departments of the city administration must be involved at some level on the project. Collaboration among them is also critical for a successful SSC implementation. This is not an easy task, due to traditional governance models and separation of powers that divide city functions into separate independent departments with little interaction<sup>28</sup>, which compromises the efficiency and hinders the synergies that can emerge with new services for the city.

It is expected that some departments would have a stronger role to play in leading the city's transformation to a more sustainable and smart model. Some of these key departments have been identified in Table 1, including examples of possible collaborations between them. Since city departments are organized differently across cities, some of the departments listed below may be named differently, or may be grouped together with others.<sup>29</sup>

**Table 1 – Examples of the role of different municipal units/divisions in SSCs**

<p>▪ <b>Urban planning unit</b></p>
<p>The urban planning unit has many responsibilities regarding the implementation of SSC. Since it has the mandate to manage the territorial setting of the city and establish the respective use of the land, this unit is one of the most important when SSC projects are to be implemented at a city level. It is important that they consider the ICT infrastructure as part of their long term city planning. Due to its integrative capacities and transversality, this unit should be the one that manages the city platform that integrates the different city services, as well as the data gathering and analysis of the city.</p> <p>This unit should also work towards the spread of more efficient, safe and smart buildings, facilities and businesses across the cities. Finally, it is an ideally placed unit to implement public participation programs where citizens can contribute to the design and planning of the city. This can be done, for instance, in the case of rebuilding a square, modifying a street, finding a new use for a public owned building or simply proposing changes in planning or design that the city needs.</p>
<p>▪ <b>Security and emergency services unit</b></p>
<p>The main role for this unit within the SSC model is to implement solutions that increase the city's resilience. To do this is recommended that ICT technologies are included in their planning and response activities. This will mean an increase of information, especially real-time information, that will enable this unit to better anticipate risk situations, and if they take place, to have a quicker reaction to limit their financial, environmental and human costs, as well as speed up restoration of normal living conditions. This unit has to be prepared to coordinate the other units in case of an emergency, especially with the health, infrastructure, transportation and citizen services units.</p>

<sup>28</sup> Readiness Guide. Smart Cities Council.

<sup>29</sup> [http://w110.bcn.cat/portal/site/Ajuntament/menuitem.38c1cee3a16e78f040f740f7a2ef8a0c/?vgnextoid=6050142be8ef0310VgnVCM10000074fea8c0RCRD&vgnnextchannel=6050142be8ef0310VgnVCM10000074fea8c0RCRD&lang=ca\\_ES](http://w110.bcn.cat/portal/site/Ajuntament/menuitem.38c1cee3a16e78f040f740f7a2ef8a0c/?vgnextoid=6050142be8ef0310VgnVCM10000074fea8c0RCRD&vgnnextchannel=6050142be8ef0310VgnVCM10000074fea8c0RCRD&lang=ca_ES)  
<http://www.cityoflondon.gov.uk/about-the-city/who-we-are/Pages/organisational-structure.aspx>  
<http://www.cityofchicago.org/city/en/depts.html>  
<https://www.cityofboston.gov/government/citydept.asp>  
<http://www.rio.rj.gov.br/orgaos-municipais;jsessionid=D0DA80C05219FFC60C4BA14200A12F71.liferay-inst5>  
<http://www.df.gob.mx/index.php>  
<http://www.municipalidaddesantiago.cl/categorias/home/municipio-2/oficinas-municipales>

<p>▪ <b>Citizen services unit</b></p> <p>This is the unit that is responsible for informing the citizens and increasing their participation and involvement within the municipality. In this sense, this unit should include new ICT based services in their technology roadmap, to promote efficiencies and cost savings on a city level. This unit will have to be in touch with all the others in order to report to the citizens on the projects that are being carried out in the city.</p>
<p>▪ <b>Unit dealing with infrastructure and ICTs</b></p> <p>The deployment of SSC requires significant new infrastructure, especially technological such as communications networks or the addition of smart meters on the existing water and energy infrastructures. This unit will have a very important role on integrating the different city systems and technologies based on a holistic ICT-based management approach.</p>
<p>▪ <b>Environmental unit</b></p> <p>In line with the focus of SSCs, this unit must promote, coordinate and evaluate the actions taken by other units to achieve the environmentally conscious and efficient use of scarce resources at the city level. ICT technologies will help to optimize resource management. For example, it can collaborate with the transportation unit in smart transport programs such as the regulation of the access to the city by car depending on the pollution values measured in real-time. With the cooperation of the housing unit, they can also lead campaigns to promote efficiency in buildings through smart buildings, or measure the improvements that are achieved as well as cooperating in the deployment of new ICT-based environmental quality sensors in green areas within the city like parks or green corridors. SSC technologies should be considered as part of the technology alternatives in climate change action plans.</p>
<p>▪ <b>Transportation unit</b></p> <p>Mobility is one of the most important issues that cities have to tackle. Many of the projects implemented in SSC are related to this unit. The objective of this unit must be to build a smart transportation network that meets the requirements of the population maximizing the efficiency and comfort and minimizing the environmental impact.</p>
<p>▪ <b>Financial unit</b></p> <p>This is a very transversal unit. Considering that municipal treasuries must face heavy financial burdens, the units of finance have to evolve to more innovative business models and make partnerships with private enterprises, based on sustainability performance KPIs. Innovations can be also made regarding collection of taxes, increasing the level of personalization of the due amount to pay in order to achieve behaviour changes in the population. ICTs can become a great tool to improve efficiency in financial processes on a city level. New SSC projects must impact the financial performance of the municipalities on a positive way.</p>
<p>▪ <b>Legal affairs unit</b></p> <p>This unit is responsible for establishing the legal and operational framework needed to guarantee the new city services development. In this sense, it is very important that these legal units understand the new vision that smart sustainable cities must have.</p>
<p>▪ <b>Water &amp; sanitation management unit</b></p> <p>Some municipalities have this unit, and some others delegate this function directly to a service company. The function of managing water resources and sewage system of a city is a challenging task. Cities are experiencing a growing stress in relation to the water resources and a proper and effective use of ICT can help deal with this issue in a sustainable manner. It is therefore a responsibility of this unit to implement smart and sustainable management of the water resources that guarantees access to water and sanitation services to current and future city dwellers.</p>
<p>▪ <b>CERT/CSIRT unit</b></p> <p>The role of the Computer Emergency Response Team (CERT) or the Computer Security Incident Response Team (CSIRT) is to provide services and support for preventing, handling and responding to computer security incidents. To do so, it is key that this unit acts as a central trusted point of contact for cyber security incident reporting and for general security issues. This unit should also build expertise in information security, incident management and computer forensics as well as enhancing information security awareness.</p> <p>Other functions this unit can also develop are to assist in improving the cyber security law, disseminating information about threats, vulnerabilities, and cyber security incidents and coordinating with other domestic and international CERT/CSIRTs and related organizations as well as sharing information and lessons learned with them.</p> <p>For more information, please see Annex 2.</p>

Finally, municipalities can make alliances with others to share knowledge and good practices. Examples of this are the Covenant of Mayors and Energy Cities, the mainstream European movement involving local and regional authorities, voluntarily committing to increasing energy efficiency and use of renewable energy sources on their territories.<sup>30</sup> Energy Cities is the European Association of local authorities in energy transition. It was created in 1990 and represents now more than 1,000 towns and cities in 30 countries.<sup>31</sup>

## 4.2 National and regional governments

National and regional governments have remit on many issues and policies that affect cities and therefore are considered a SSC stakeholder. For instance, policies related to deployment of new infrastructure such as optic fibers or mobile connectivity, or related to subjects like health or education that without being specific to cities are also included in the SSC; usually belong to the national government. Similarly, much of the information that can be made available to the citizens through the open data platforms belongs to the central administration.

In order to drive the transition to SSC, national governments should define legal frameworks that enable the implementation of many of the smart sustainable cities features. For example in China, the National Development and Reform Commission (NDRC), designs the macro policies of national economic and social development. In order to build SSC, NDRC also leads the strategy planning for smart cities, coordinating with dozens of units of central government. Another clear example can be found in Spain, where the policies that regulate low-voltage distribution in multi-family blocks prevents the installation of electric vehicle charging points in communal parking areas. A modification to this policy that includes a solution to this issue will be essential to allow the widespread adoption of electric vehicles on a city level.

Discussions have begun about on the application of the principles behind SSC to regions, either to analyse urban regions around a big city, or agglomerations of small towns. In the first case, it is about coordinating the urban area as a whole since usually many people from the surrounding areas work at the city centre and there is a lot of mobility around the entire urban area. In the second case, the idea is to generate efficiency by creating collaborations between the towns and villages in an area. For instance, if they want to provide a service that would not be cost-effective for a town of their size, they can provide it together and benefit from economies of scale. In these cases, regional governments can have a leading role helping the mayors of the municipalities involved, and acting as coordinators of these clusters, and as promoters of the initiatives.

As in the case of municipalities, it is also interesting to analyse the different units or ministries involved, as illustrated in Table 2. As in the case of city units, government units or ministries are not the same in all countries, so the names used in the examples may differ in some cases.

**Table 2 – Examples of the role of different national Ministries and units in SSCs**

<ul style="list-style-type: none"> <li>▪ <b>Ministry of Infrastructure, Industry and Information Technology</b></li> </ul>
<p>This is the ministry that has to fulfil the challenge of creating or modifying the policies related to infrastructure deployment and therefore can be decisive in the development of SSC. Issues regarding Electromagnetic Field (EMF) planning considerations on a national level must be transmitted by this unit to local governments and their particular units dealing with this issue.</p>

<sup>30</sup> Covenant of Mayors. [http://www.covenantofmayors.eu/index\\_en.html](http://www.covenantofmayors.eu/index_en.html)

<sup>31</sup> Energy Cities. <http://www.energy-cities.eu/>

<ul style="list-style-type: none"> <li>▪ <b>Ministry of Science and Technology</b></li> </ul>
<p>This is the ministry that launches or should promote the research of SSC within the high technology research programmes.</p>
<ul style="list-style-type: none"> <li>▪ <b>Ministry of Environment</b></li> </ul>
<p>Similarly to the municipal unit, the Ministry of Environment must work transversally to ensure that actions are taken across the other ministries towards a more sustainable country, considering and integrating the role of ICTs. They should also be involved in monitoring and measuring the current state as well as the improvements achieved. This ministry also organizes awareness campaigns to encourage sustainable habits, sometimes together with other ministries like the transportation or energy ministries. Climate change units must also work on the inclusion of ICTs into national and local climate change programs.</p>
<ul style="list-style-type: none"> <li>▪ <b>Ministry of Energy</b></li> </ul>
<p>Even if there are examples of cities deploying first pilot projects of the so-called smart grids, the electrical grid, faring system and policies, is still remit of the central government. Therefore the support of the Ministry of Energy is needed for the deployment of smart grids at the national level. The same can apply regarding other energy systems such as the natural gas network with the deployment of smart meters. This ministry should develop policies that promote and regulate the upgrade of the energy networks to become smarter and more efficient.</p>
<ul style="list-style-type: none"> <li>▪ <b>Health Unit</b></li> </ul>
<p>The health unit can benefit from the features developed in the frame of the SSC in order to provide a better service to the patients or service users, and at the same time, increasing its efficiency. There are the technological solutions that can be comprised in the term "e-Health". This includes solutions such as telemedicine, healthcare information systems or health apps on smartphones to name a few. At the same time, the health unit can benefit from applying the concept of cooperation that is intrinsic in SSC initiatives. For instance, it can be synchronized with the emergency units both to react quickly to an emergency that will need medical resources, and/or alert emergency services in case of a pandemic.</p>
<ul style="list-style-type: none"> <li>▪ <b>Ministry of Education</b></li> </ul>
<p>Similarly to the health unit, the Ministry of Education can take advantage of technological solutions to improve its services. This includes e-learning which can be useful for children that cannot attend school or to make long life learning more accessible to adults, among others.</p>
<ul style="list-style-type: none"> <li>▪ <b>Transportation Unit or Ministry</b></li> </ul>
<p>Although urban mobility is usually remit of the municipal government of each city, regional or national governments are entrusted with ensuring good connectivity between cities and towns as well as international destinations. Thus, multiple units will have to get together and collaborate in order to cover the transportation-related requirements of SSC.</p>
<ul style="list-style-type: none"> <li>▪ <b>Ministry of Public Security</b></li> </ul>
<p>The Ministry of Public Security (MPS) is the principal police and security authority, as well as the <a href="#">government</a> agency that exercises oversight and is ultimately responsible for day-to-day law enforcement. The Ministry operates the system of <a href="#">Public Security Bureaus</a>, which are broadly the equivalent of police forces or police stations. The MPS must work transversally to ensure the safety and security of the cities, as well as emergency responses that rely on the wide usage of ICTs.</p>

Adapted from the author's analysis and reviewed contributions.

### 4.3 City services companies

Among the companies that provide services for the SSC, it is possible to identify two main groups. The first are the traditional providers of city services, such as water management, waste collection or transportation, which should add new functionalities to become more efficient and smart. This first group is usually contracted by the municipality. The second group are the new companies that specialize in SSC and provide new services derived from SSC such as (but not limited to) mobile applications, sensor deployment or software for fleet management. The companies in this second group, depending on the services they offer, can either be contracted by the municipality or offer



their services directly to the citizens. In most cases, these companies are the ones that provide the equipment and deploy the sensors.

To help on the implementation of SSC, city service companies must learn to work with KPI based business models and work together with municipalities in this transition. As a result, these companies will have to increase the efficiency of their solutions, as their performance will be quantified and evaluated. This will increase competitiveness of the service companies.

When creating their vertical solutions, city services companies should try to build these solutions in a way that they can adapt to standard transversal platforms, so that information from all the services can be accessed and disseminated.

A difficulty that can be encountered in some cases, especially in companies that belong to the first group, is the lack of expertise or capacity to integrate ICTs on their processes since the "know-how" of these companies is usually focused on the specific service they provide. At the same time, these companies are used to work independently in their vertical solution and the change to a more collaborative and interdependent model of service provision is not always easy.

#### 4.4 Utility providers

Utility providers offer services, such as electricity and gas, directly to the citizen. They usually integrate production, distribution and commercialization aspects, which provide them with expertise in all the different links of the value chain.

They are responsible for the deployment of smart grids, smart metering systems and deployment of charging points for electrical vehicles, and therefore, their involvement in SSC initiatives is essential for their success.

Utility providers cover extensive parts of the city's territory. For this reason, the upgrade of their systems and the inclusion of ICT in their infrastructures implies a massive rollout and requires a considerable investment. One of the problems that they face nowadays is the morphology of the demand curve, which has peak and valley hours with very different consumption values. In the case of the electricity providers is complex to adapt to this curve, which is one of the issues that constraints the development and implementation of renewable energies. With the implementation of ICT based solutions, a smarter and sustainable network could flatten the demand curve and also increase the predictability of the demand.

#### 4.5 ICT companies (e.g., telecom operators, start-ups, software companies)

The main role of ICT companies is to provide the ICT infrastructure and solutions that will support and integrate the services of SCC. It is important that these technological solutions are global and standard in nature, so that different vertical solutions can be easily integrated throughout the SSC.

Due to the diversification they have experienced, Telecom operators, for example, can provide experience and expertise on the development of the platforms needed to integrate SSC services, as well as on the services themselves<sup>32</sup>. Because of their transversal nature, these platforms can encourage cooperation between services, and enable the creation of efficiencies. In order to drive the change towards SCC, ICT companies have to develop new financially sustainable business models that guarantee the implementation of smart solutions.

---

<sup>32</sup> Informe Anual Smart Cities. Telefonica.

They also have to keep researching and innovating in order to provide even better technical solutions. In this regard, big Telecom operators or mature software companies which are usually more financially stable, could redirect more resources toward the R&D budget, and act as important actors in the SSC implementation phase.

New and innovative ICT companies and start-ups can also provide also particular solutions to smart sustainable cities challenges. Local companies can understand in a better way city operation and have proximity with citizens.

It should also be acknowledged that the ICT companies' compliance with standards plays a key role in the achievement of compatibility, replicability and scalability of the SSC solutions implemented in different cities.

## 4.6 Non-governmental organizations (NGOs)

One of the aims of SSC is to increase social sustainability. NGOs, with their expertise on social inclusiveness and equity, are a key asset to achieve this goal. One of their roles should be to raise awareness on the concerns of the population, especially in regards to challenges left unattended or that affect the weakest sectors of the society. As they already do regarding other issues, NGOs would be ensuring that all society is and feels included in new SSC strategies. NGOs can also benefit from the solutions and the technology adopted by the SSC in order to widen their scope, improve their services, reach out to broader audiences, and thus expand their impact.

## 4.7 International, regional and multilateral organizations

There are different ways in which international, regional and multilateral organizations can help move forward SSC initiatives. They include UN agencies with specialized mandates in various fields that contribute to the implementation of SSC models. Examples include (but not limited to) ITU, UNESCO, UNEP, UNDP, UNFCCC and UN Habitat. They can be promoters of initiatives towards human development, environmental sustainability and improvement of quality of life worldwide. They can provide funds, through their raising awareness and technical assistance programs, to help kick-starting SSC projects.

An example of a multilateral program that fulfils these two objectives is the "City energy Efficiency transformation initiative" a three-year technical assistance program with an initial budget of US\$9 million. This program is led by the World Bank's Energy Sector Management Assistance Program (ESMAP).<sup>33</sup> It provides technical assistance to city governments in developing countries to integrate energy efficiency into the core of city planning through programs that build their capacity, map out citywide efficiency strategies, and facilitate access to development financing.

Another example of an international and multilateral technical assistance program is the "Emerging and Sustainable Cities Initiative (ESCI)", a program by the Inter-American Development Bank (IDB) that helps intermediate cities in Latin America and the Caribbean in identifying prioritizing and structuring projects to improve their environmental, urban and fiscal sustainability.<sup>34</sup> This program provides emerging cities with a set of tools to identify key bottlenecks that they may face in their path towards sustainability, to weigh and prioritize the identified problems to guide investment

---

<sup>33</sup> <https://www.esmap.org/>

<sup>34</sup> Emerging and Sustainable Cities Initiative (ESCI) - Inter-American Development Bank (IDB) <http://www.iadb.org/en/topics/emerging-and-sustainable-cities/responding-to-urban-development-challenges-in-emerging-cities,6690.html>

decisions in the sectors that may generate more positive impacts and to find specific and adequate solutions according to a cost-benefit analysis.

Lastly, by creating knowledge exchange platforms, these organisations can drive collaboration between stakeholders, and promote the replication of successful initiatives. An example of that is the Smart Cities Stakeholders Platform created by the European Commission or the ITU's Focus Group on Smart Sustainable Cities.<sup>35</sup>

## 4.8 Industry associations

This category includes some industry associations from the ICT and electrical sectors. Many of these industry associations work to promote the deployment of SSC with the objective of extending this new market.

A clear example of this is the Asociación Iberoamericana de Centros de Investigación y Empresas de Telecomunicaciones (AHCJET)<sup>36</sup>, the main organizer of the Ibero-American Meeting of Digital Cities (In Spanish, Encuentro Iberoamericano de Ciudades Digitales).<sup>37</sup>

Another example is China's Strategic Alliance of Smart City Industrial Technology Innovation, founded in 2012 under the guidance of the Ministry of Science of Technology (MOST). The alliance is a non-profit organization with 68 members from enterprises, government institutions and academia. Through the study of common technologies of smart cities, the alliance aims to innovate on the standardization and on dedicated technologies, in order to apply them in pilot smart cities and projects. It is also very active in international collaboration on behalf of MOST.<sup>38</sup>

Another example can be found with the GSM Association (GSMA), an international association of mobile operators and related companies that has created the GSMA Smart Cities initiative focused on accelerating the adoption of mobile based solutions and services.<sup>39</sup>

The Institute of Electrical and Electronics Engineers (IEEE) also aims to assist municipalities in the correct use of technology and to raise awareness of the benefits of its deployment to overcome the challenges presented by urban population growth. Towards that aim, they have created the IEEE Urbanization Challenge<sup>40</sup>, an initiative that brings to selected cities assistance and advice from experts, workshops, education resources (including support for Masters and PhD students), the organization of an international conference on smart cities, and a knowledge repository. The initiative selects a city per continent each year. The requisites includes the existence of an strategic plan and availability of funding, willingness of the administration to share the experience during the process, existence of a local section of IEEE and of a university interested in the field of smart cities. The first city to be included to the program was Guadalajara (Mexico).

<sup>35</sup> Smart Cities Stakeholders Platform - EU <http://eu-smartcities.eu/>

<sup>36</sup> Asociación Iberoamericana de Centros de Investigación y Empresas de Telecomunicaciones (AHCJET) <http://ahciet.net/index.php/ahciet/quienes-somos>

<sup>37</sup> Encuentro Iberoamericano de Ciudades Digitales <http://www.ciudadesdigitales2013.com/>

<sup>38</sup> China Strategic Alliance of Smart City Industrial Technology Innovation. <http://www.smartcityunion.cn/>

<sup>39</sup> GSMA Smart Cities initiative. <http://www.gsma.com/connectedliving/smart-cities/>

<sup>40</sup> IEEE Urbanization Challenge [www.itu.int/en/ITU-T/Workshops-and-Seminars/ssc-la/201312/Documents/S1P1\\_Victor\\_Rosillo.ppt](http://www.itu.int/en/ITU-T/Workshops-and-Seminars/ssc-la/201312/Documents/S1P1_Victor_Rosillo.ppt)

There are also associations of companies that cluster companies from different sectors. This is the case of the Smart Cities Council, which defines itself as an advisor and market accelerator that promotes the move to smart, sustainable cities with the objective of contributing to its partners' business success.<sup>41</sup>

## 4.9 Academia, research organizations and specialized bodies

The academia is a crucial piece on the SSC landscape, and has many roles to play. It has to educate a new wave of city professionals: urban planners, technologists and economists that are prepared to deal with the challenges of the new urban landscape. This has already started to occur; as different universities around the world are launching specific post-graduate programs aimed at creating professionals specialized in this field. The University of Girona (Spain)<sup>42</sup> has been a pioneer in this regard, followed by others such as the University of Madrid<sup>43</sup> and the University of London<sup>44</sup>, who are launching their own programs.

Research organizations also have a role to play by participating in the on-going conversation on how to better drive cities to the smart and sustainable model, and it must have a voice on the standardization processes.

Building on documented experienced and conceptualizations, the academia and research organizations can even make a science of cities. For example, researchers at the Santa Fe Institute are already doing so through a research initiative titled Cities, Scaling and Sustainability, aimed at developing theoretical insights about that can inform quantitative analyses of the cities' long-term sustainability.<sup>45</sup> There are also universities that have created labs specially focused on this subject, like the Senseable Cities Lab from MIT<sup>46</sup> and the Smart city Lab from the University of Bologna.<sup>47</sup>

Universities, associated labs and research parks, can be very helpful in the development of SSC models by driving research and creating innovation. Research in other fields, not specifically focused in cities, such as mathematics, data mining, analytics, economics, and computer vision, among others, can help develop useful solutions and tools for SSC.

Specialized bodies such as consulting firms, with expertise on SSC projects are able to assess and propose new ideas for SSC. They are also able to assess the initial situation before a project takes place and define the baseline upon which the improvements can be measured. This is essential on any urban and SSC project, to be able to prove and quantify the improvements achieved. With their expertise in measuring methods and framework definition, these bodies can assist city managers and policy makers on the transition to this SSC new model.

---

<sup>41</sup> Smart Cities Council <http://smartcitiescouncil.com/category-vision>

<sup>42</sup> Master in Smart Cities. University of Girona. <http://www.udg.edu/tabid/8439/Default.aspx?ID=3105M0413&language=en-US&IDE=5>

<sup>43</sup> Master in Citi Sciences. Universidad Politécnica de Madrid. <http://www.citysciences.com/>

<sup>44</sup> Smart Cities courses at CASA. University College London. <http://mcsmartcities.org/>

<sup>45</sup> <http://www.santafe.edu/research/cities-scaling-and-sustainability/>

<sup>46</sup> Senseable Cities Lab. Massachusetts Institute of Technology (USA). <http://senseable.mit.edu/>

<sup>47</sup> Smart city Lab. University of Bologna (Italy). <http://smartcity.csr.unibo.it/>

Finally, through technology transfer programs and partnerships with the private sector, universities, research organizations & specialized bodies can also be a source of innovation for the private sector, and promote new business creation in the form of spin offs.

#### 4.10 Citizens and citizen organizations

Citizens are the key to transform a digital city into a smart city.<sup>48</sup> Citizens are the ultimate users of SSC services, covering the associated costs via taxes or, in some cases, via fees. Therefore, it is important that they are informed on the features and the benefits of each of those services, so they can value them. Without achieving this, citizens could perceive SSC projects as an unnecessary expenditure, rather than as a proper investment of their taxes.

The value of the citizens' role can be viewed from multiple perspectives: as a source of data, the concept of citizen as a sensor of local/real-time information, as a source of ideas through citizen participation mechanisms, as a receiver of information and as end users of city services.

We can find many examples of the citizen's as sources of data, including the use of ICT applications that, with the user permission, gather data from the sensors embedded in smartphones to identify issues such as the state of the road<sup>49</sup>, or that allow users to report incidents on the street.<sup>50</sup> Data mining from social networks allows to predict events, or to learn the opinion of the population on key issues and even automated sensors to collect environmental parameters that anyone can install at home.<sup>51</sup> There is a lot of innovation taking place in this field, with new applications and projects appearing every day and allowing citizens to contribute to make their cities more sustainable.

Citizen participation is key to enable a citizen-centred approach in cities. Technology can be of help to carry out mass opinion surveys and participatory processes, but it is important to ensure that everyone can participate. This can be achieved by providing means of participation to sectors of the population that may not have easy access to communication technologies like the elderly or economically constrained sections of the population.

Citizen as information receivers and users of services refer to information from the city such as real time traffic state, the public transport timetables and safety alerts, to name a few.

It is important to emphasize that the citizen is the final user of the city and the city services, and therefore, it is who will benefit from a shift towards a smarter, more sustainable urban model.

#### 4.11 Urban planners

Urban planners develop plans and programs for the use of land in cities. Their plans help create communities, accommodate population growth, and revitalize physical facilities in towns, cities, counties, and metropolitan areas.<sup>52</sup>

Urban planners are key actors for smart sustainable cities. In some instances, these stakeholders perceive smart city strategies with some degree of reluctance and scepticism due to the dominant role given to technology over other city dimensions. To most planners, the lack of understanding of

<sup>48</sup> Overview and Role of ICT in Smart Sustainable Cities. Technical Report WG1 FG on SSC.

<sup>49</sup> Street Bump <http://streetbump.org/about>

<sup>50</sup> Repara Ciudad <http://reparaciudad.com/>

<sup>51</sup> Smart Citizen Kit <http://smartcitizen.me/pages/sck>

<sup>52</sup> <http://www.bls.gov/ooh/life-physical-and-social-science/urban-and-regional-planners.htm#tab-2>

city's complexities and dynamics may put into question, and even render useless large investments made on smart initiatives.<sup>53</sup> In this sense it is important that urban planners participate actively in the design and implementation on smart sustainable city projects to foster a broader understanding of three basic characteristics of contemporary cities: complexity, diversity and uncertainty. A closer look at those three aspects may provide a clearer and more in-depth understanding of the cities' nature and identity, particularly to stakeholders that lack an urban background.

## 4.12 Standards Developing Organizations (SDOs)

SDOs are essential to the deployment of SSC as they can provide a standardized framework and a minimum set of characteristics to define and implement SSC. One of their priorities should be to develop a common terminology for all stakeholders to bring clarity and harmonization in this field.<sup>54</sup>

In addition, the success of SSC implementation will depend on the definition of measurement methods to assess the performance, smartness and sustainability of city services based on ICT technologies.

There is a need to develop specific standards that can allow the various technologies involved in SSC to be able to interoperate.<sup>55</sup>

ITU with its Focus Group on Smart sustainable Cities has developed a Technical Report which identify the standardization gaps for SSC.

Having identified the multiple stakeholders and the diverse roles that they play in SSCs, the following section provides a series of specific recommendations in order to ensure that these multiple views and contributions are effectively integrated as part of smart sustainable city strategies.

## 5 Conclusions

---

As described throughout this report, the identification of SSC stakeholders is a critical component in the design and implementation of SSC strategies and projects.

Cooperation between stakeholders is key for cities that want to become smart and sustainable. A thorough study of the characteristics and roles of the stakeholders can be useful to identify the relationships that exist among them, create useful synergies, and allow the integration of stakeholders' views on SSC projects and initiatives.

In order to successfully develop an analysis of SSC stakeholders in a given city, the following three steps should be considered:

- Step 1: Identification of all stakeholders involved. It is very important to develop an initial list of stakeholders for a SSC project development. This list is not a closed list and can be updated.
- Step 2: Categorization of the stakeholders. It is important to categorize stakeholders based on their interests and to identify all the relationships among them. It is advisable to develop a stakeholder diagram and a map of their relations and interactions so as to facilitate further analysis.

---

<sup>53</sup> Universidad Politécnica de Madrid, contribution to FGSSC.

<sup>54</sup> ISO Focus Magazine. Volume 4, No. 1, January 2013, ISSN 2226-1095.

<sup>55</sup> ISO Focus Magazine. Volume 4, No. 1, January 2013, ISSN 2226-1095.



- **Step 3: Detailed analysis of selected stakeholders and engagement.** This is the most important step of the process. In order to succeed, a detailed analysis of all stakeholders must be done. This is a reiterative process that can be repeated as new stakeholders emerge and new projects and initiatives are carried out in a SSC project or initiative. It is important to have a final summary table reflecting the stakeholders' aims, challenges, potentials and constraints, and especially their role and contribution to the SSC challenge (as reflected in Annex 1). This will set the basis for proper stakeholder's engagement.

For a smart sustainable city initiative to succeed, it is important to identify all the stakeholders involved in order to guarantee its success and sustainability. Cities are complex systems with several stakeholders. In a smart sustainable city, stakeholders interact together to build a resilient city which is smart, sustainable and innovative. In addition, it must also be taken into account that cities from developed and developing countries differ in terms of their existing infrastructure as well as the multi-stakeholders' ability to implement ICTs within the city. In other words, what may be feasible for one city may be challenging for another.

It is imperative that a multi-stakeholder approach is applied to achieve the highest rate of success by working together as a team irrespective of the city they are based in.

## Annex 1 Summary of Stakeholder Identification, categorization and analysis

Stakeholder	Scale/ sector	Aims and challenges		Potential and constraints		Role/contribution to SSC rollout
Municipalities, City Council and city administration	Local Public	<ul style="list-style-type: none"> <li>- Increase efficiency (energetic as well as economic).</li> <li>- Increase environmental sustainability.</li> <li>- Aim to give the best service to citizens.</li> </ul>	<ul style="list-style-type: none"> <li>- Shrinking budgets.</li> <li>- Growing demand of the voters for transparency, citizen participation.</li> <li>- Pressure by local, national and international agreements and targets for sustainable development.</li> </ul>	<ul style="list-style-type: none"> <li>- Expertise on city management.</li> <li>- In charge of city services provision.</li> </ul>	<ul style="list-style-type: none"> <li>- Lack of interdepartmental coordination.</li> <li>- Lack of professionals with specific knowledge on SSC.</li> <li>- Constrains in allocating budget.</li> </ul>	<ul style="list-style-type: none"> <li>- It is a strong driver of SSC.</li> <li>- Promote SSC initiatives and decide the roadmap to follow and specific solutions to be implemented.</li> <li>- Engage citizens and communicate them benefits of SSC.</li> <li>- Monitor city services: define KPIs and evaluate them.</li> <li>- To promote SSC services provision and integrated management.</li> </ul>
National and regional governments	Supralocal Public	<ul style="list-style-type: none"> <li>- Increase efficiency guarantee security of resources. (natural &amp; economic resources).</li> <li>- Increase environmental sustainability of the country.</li> <li>- Aim to give the best service to all citizens; including and above all ICT technologies.</li> </ul>	<ul style="list-style-type: none"> <li>- Growing demand of the voters for transparency, citizen participation.</li> <li>- Pressure by international agreements and targets for sustainable development and climate change.</li> </ul>	<ul style="list-style-type: none"> <li>- In charge of policies that can directly affect SSC deployment.</li> <li>- To promote the intensive use of ICTs facilitating technology development.</li> </ul>	<ul style="list-style-type: none"> <li>- Lack of coordination among ministries.</li> <li>- Lack of professionals with specific knowledge on SSC.</li> </ul>	<ul style="list-style-type: none"> <li>- Define policies and legal frameworks that enable SSC deployment.</li> <li>- Promoting and managing implementation of "smart regions".</li> <li>- To facilitate ICT technology development and competition.</li> </ul>

Stakeholder	Scale/ sector	Aims and challenges		Potential and constraints		Role/contribution to SSC rollout
City services companies	Local Private	<ul style="list-style-type: none"> <li>– Increase efficiency of their processes.</li> <li>– Provide a service with a greater added value (or a new service in some cases).</li> <li>– To grow their business and provide SSC solutions.</li> </ul>	<ul style="list-style-type: none"> <li>– With their current functioning, city services will not be able to cover the future demand due to population growth.</li> <li>– City services are not efficient enough to fulfil the sustainability challenges cities are facing.</li> </ul>	<ul style="list-style-type: none"> <li>– Expertise on city services functioning, needs and characteristics.</li> <li>– Know-how on the service they provide and citizens' needs.</li> </ul>	<ul style="list-style-type: none"> <li>– Some of them do not have enough expertise and/or capacity to include ICT in their processes.</li> <li>– Some of them are used to work independently in vertical solutions, not cooperating with the rest of the services.</li> <li>– Some of them may require innovation transformations.</li> </ul>	<ul style="list-style-type: none"> <li>– Provide their expertise to collaborate with municipalities and ICT companies to develop integrated collaborative models.</li> <li>– Change towards "smart" and "KPI-based" city service models.</li> <li>– In some cases: create a new service that covers a new or an uncovered urban need.</li> </ul>
Utility providers	Supralocal Private	<ul style="list-style-type: none"> <li>– Increase efficiency of their processes.</li> <li>– Flatten the demand curve.</li> <li>– Increase the predictability of the consumer's needs.</li> </ul>	<ul style="list-style-type: none"> <li>– Considerable resource losses (water, gas or energy) on their supply chains.</li> <li>– Challenges for massive deployment of new technologies, especially time &amp; economic resources.</li> </ul>	<ul style="list-style-type: none"> <li>– Expertise in all the links of the value chain: production, distribution and commercialization.</li> </ul>	<ul style="list-style-type: none"> <li>– Due to their size, the upgrade of their systems and the inclusion of ICT in their infrastructures could be a challenge.</li> </ul>	<ul style="list-style-type: none"> <li>– Responsible for the deployment of some SSC features: smart grid (energy, gas, etc.) and smart water management.</li> <li>– Can also implement the SSC solutions outside the city, in all their value chain.</li> </ul>

Stakeholder	Scale/ sector	Aims and challenges		Potential and constraints		Role/contribution to SSC rollout
ICT Companies	Supralocal Private	<ul style="list-style-type: none"> <li>– Finding new fields for business development.</li> <li>– To provide services based on positive business cases.</li> </ul>	<ul style="list-style-type: none"> <li>– Difficulties to access cities services contests to offer SSC projects that are still directed to vertical city services.</li> <li>– Lack of legal &amp; commercial framework to provide SSC services.</li> </ul>	<ul style="list-style-type: none"> <li>– Experience and expertise on transversal solutions and integration of services.</li> <li>– R+D departments with significant budgets.</li> <li>– Expertise in developing business models.</li> </ul>	<ul style="list-style-type: none"> <li>– Lack of expertise in city management services.</li> <li>– Urgency to deploy ICT services due to customers' demands.</li> </ul>	<ul style="list-style-type: none"> <li>– Provide the ICT infrastructure to support and integrate SSC services. It has to be standard, compatible and scalable.</li> <li>– Research and innovate to provide better technical solutions.</li> <li>– Develop innovative and financially sustainable business models to enable SSC implementations.</li> </ul>
NGOs	Local & Supralocal	<ul style="list-style-type: none"> <li>– Ensuring social sustainability, inclusiveness and equity on a local and national level.</li> </ul>	<ul style="list-style-type: none"> <li>– They do not have an active role in SSC solutions deployment.</li> <li>– With increasing urban populations, inequity, poverty and social strains are going to be increased in cities.</li> </ul>	<ul style="list-style-type: none"> <li>– Experience on raising awareness of concerns of the population, on watching over the weakest sectors of society and developing initiatives.</li> <li>– Knowledge on social sustainability.</li> <li>– Impartiality and legitimacy to raise issues.</li> </ul>	<ul style="list-style-type: none"> <li>– Limited resources: (economic, human...).</li> <li>– Limited power of influence on local, national and international agendas.</li> </ul>	<ul style="list-style-type: none"> <li>– Give advice on how to achieve social sustainability.</li> <li>– Raise awareness of concerns of the population.</li> <li>– Ensure inclusiveness of all society in the SSC model.</li> </ul>

Stakeholder	Scale/ sector	Aims and challenges		Potential and constraints		Role/contribution to SSC rollout
International, Regional and Multilateral Organizations	Local & Supralocal	<ul style="list-style-type: none"> <li>– Improving quality of life of citizens worldwide.</li> <li>– Ensuring social sustainability, inclusiveness and equity.</li> <li>– Promoting new business models on city administration.</li> </ul>	<ul style="list-style-type: none"> <li>– To support sustainability management technical advice to local governments.</li> </ul>	<ul style="list-style-type: none"> <li>– Expertise on developing initiatives and driving change.</li> <li>– Workforce of experts in different fields.</li> <li>– Technical and economic resources.</li> </ul>	<ul style="list-style-type: none"> <li>– Lack of expertise in SSC models.</li> <li>– They have to rely on the bodies they are supporting (national or municipal governments and administrations) since they have no decision-making capabilities.</li> </ul>	<ul style="list-style-type: none"> <li>– Provide funds and make promotion programs to drive SSC.</li> <li>– Provide technical assistance and documentation.</li> <li>– Create knowledge exchange platforms.</li> </ul>
Industry associations	Supralocal	<ul style="list-style-type: none"> <li>– Promote an initiative their associate industries are interested in.</li> <li>– Finding new fields for business development for their associates.</li> </ul>	<ul style="list-style-type: none"> <li>– Same problems as the industries they represent.</li> </ul>	<ul style="list-style-type: none"> <li>– Legitimacy to raise the subjects on behalf of the sector.</li> </ul>	<ul style="list-style-type: none"> <li>– Lack of expertise in SSC models.</li> <li>– They have to rely on their associated.</li> </ul>	<ul style="list-style-type: none"> <li>– Bring the SSC issues to the table for debate.</li> <li>– Build spaces for discussion.</li> <li>– Facilitate financing options for the development of SSC.</li> </ul>

Stakeholder	Scale/ sector	Aims and challenges		Potential and constraints		Role/contribution to SSC rollout
Academia, research organizations and specialized bodies.	Local & Supralocal	<ul style="list-style-type: none"> <li>– Lack of experience &amp; resources for implementing SSC projects including business &amp; local government vision.</li> </ul>	<ul style="list-style-type: none"> <li>– To study SSC as a new trend which has impact in the sustainable development of society and has a very technical component.</li> <li>– To develop new field of research and associated studies (new degrees or masters).</li> </ul>	<ul style="list-style-type: none"> <li>– Experience in developing "science".</li> <li>– Research facilities, workforce and know-how.</li> <li>– Capacity to innovate.</li> <li>– A certain level of impartiality and an external and holistic vision of SSC. Experience in measuring, defining baselines,</li> <li>– Teams of specialized professionals.</li> </ul>	<ul style="list-style-type: none"> <li>– In some cases, difficulties when cooperating with the private sector.</li> <li>– Distancing from the reality when delving into more theoretical issues.</li> <li>– Often they are not recognized as stakeholders in the SSC model.</li> <li>– Lack of funding for investments.</li> </ul>	<ul style="list-style-type: none"> <li>– Develop a science of cities, to study them as the complex systems they are.</li> <li>– Participate on SSC standardization activities.</li> <li>– Drive research and innovation in fields related to SSC.</li> <li>– They have to include the social aspects on the debate.</li> <li>– Assist city managers and policy makers with the transition to the new model in regard to measuring methods, baseline definition.</li> </ul>
Citizens and citizen organizations	Local	<ul style="list-style-type: none"> <li>– Achieve better quality of life.</li> <li>– They need access to better city services.</li> <li>– They are the final beneficiaries of SSC.</li> </ul>	<ul style="list-style-type: none"> <li>– Need for more active participation in decision making.</li> <li>– They suffer the strains of urban growth: traffic congestion, pollution.</li> </ul>	<ul style="list-style-type: none"> <li>– Source of data.</li> <li>– Users of the city: they can provide information on what they need.</li> <li>– They can be a source of innovation.</li> </ul>	<ul style="list-style-type: none"> <li>– Lack of knowledge of the ICT implications of SSC models.</li> <li>– Lack of knowledge of the benefits that SSC could bring to them.</li> </ul>	<ul style="list-style-type: none"> <li>– Key to go from "intelligent" to "smart sustainable" city: they have to use the new applications.</li> <li>– They are a source of data.</li> <li>– Citizen participation, engagement in the SSC project.</li> <li>– Citizens must recognize that SSC need business models that include the service price.</li> </ul>



Stakeholder	Scale/ sector	Aims and challenges		Potential and constraints		Role/contribution to SSC rollout
Urban Planners	Local	<ul style="list-style-type: none"> <li>– Achieve better quality of life.</li> <li>– Promote city sustainability.</li> </ul>	<ul style="list-style-type: none"> <li>– To develop short- and long-term plans to create, grow, and revitalize communities and areas in cities.</li> </ul>	<ul style="list-style-type: none"> <li>– Experience in city planning.</li> <li>– Understanding of city needs from a non-technological perspective.</li> </ul>	<ul style="list-style-type: none"> <li>– Reluctant to a technology-only approach for SSC.</li> <li>– Not aware of smart technologies for cities.</li> </ul>	<ul style="list-style-type: none"> <li>– Include in their studies and city planning processes the use of ICTs to promote SSC as a part of a broader approach.</li> <li>– To give the guidance to SSC stakeholders on city planning needs.</li> </ul>
Standardization Bodies	Supralocal	<ul style="list-style-type: none"> <li>– Define standards in a new field that has not been standardized yet to assess the performance of SSCs.</li> </ul>	<ul style="list-style-type: none"> <li>– To develop a common language for all stakeholders involved.</li> </ul>	<ul style="list-style-type: none"> <li>– Expertise in development of standards of ICTs &amp; sustainability.</li> </ul>	<ul style="list-style-type: none"> <li>– They have to rely on their members (from private and public sector, academia...) and reach consensus.</li> <li>– Lack of expertise in city management.</li> </ul>	<ul style="list-style-type: none"> <li>– Laying the framework for SSC and defining standards for this new model.</li> <li>– Identify standardization gaps on SSC field.</li> </ul>

## Annex 2

### SCC – CERT/CSIRT/SOC

#### Definitions

---

- The term **CERT** (Computer Emergency Response Team) refers to a team of IT security experts whose main business is to respond to computer security incidents. The term CERT is a registered service mark of Carnegie Mellon University (CMU).
- The term **CSIRT** (Computer Security Incident Response Team) also refers to a team of IT security experts designated to respond to computer security incidents. This term, however, is more accurate since it reflects a broader array of security services provided, beyond reactive functions.
- Term like **SOC** (Security Operations Center) is also used. Although his name suggest mainly an operational responsibility, it is often tasked with similar broad duties as a corporate CERT or CSIRT.

#### Description

---

- A CERT/CSIRT is an organization or team that provides services and support, to a defined constituency, for preventing, handling and responding to computer security incidents.
- This means that should work proactively as well as reactively and will play a critical role in the coordination of several subjects working like a bonding in order to provide a quick and effective response to any security issue.

#### Objectives

---

- Enhance information security awareness.
- Build expertise in information security, incident management and computer forensics.
- Enhance the cyber security law and assist in the creation of new laws.
- Provide a central trusted point of contact for cyber security incident reporting and for general security issues.
- Establish a center to disseminate information about threats, vulnerabilities, and cyber security incidents.
- Coordinate with other domestic and international CERT/CSIRTs and related organizations.
- Share information and lesson learned with other CERT/CSIRT/response teams and appropriate organizations and sites.
- Become an active member of recognized security organizations and forums.

## Type of services

---

The portfolio of services that is widely used as the de facto set of CERT/CSIRT services is organized in three categories:

- **Proactive Services:** performed before an incident occurs or is detected.
- **Reactive Services:** executed when an incident becomes known.
- **Security Quality Management Services:** continuously executed in order to ensure incidents can be dealt with.

## Type of Authority

---

- The best approach suggested to build the City CERT/CSIRT is to build it using the Shared Authority model.
- A CERT/CSIRT Manager need to be nominated to lead the CERT/CSIRT .
- CERT/CSIRT Manager should available on call on 24/7 basis.
- CERT/CSIRT Manager is responsible for coordinating all emergencies that can be raised by SOC and by any other department inside the City IT .
- Initially the CERT/CSIRT team can be virtual, meaning that some resources will be identified in each team involved to be available to join the CERT/CSIRT Manager in case of emergency.
- If this approach is not totally effective a dedicated team needs to be built to aid the CERT/CSIRT Manager for managing emergencies faster.

## Mission and scope

---

When CERT/CSIRT are created:

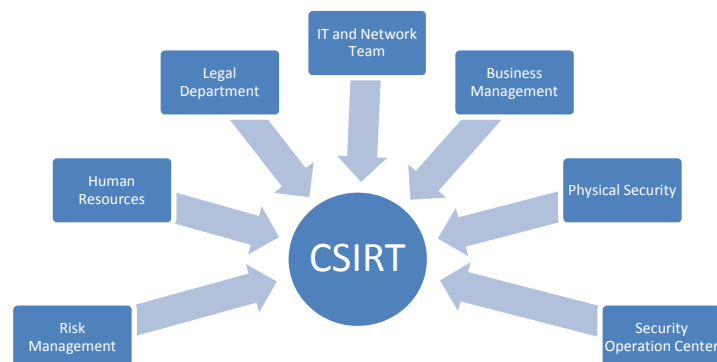
- The Manager should clearly define a mission statement for CERT/CSIRT.
- The Mission Statement should clearly define the intentions of CERT/CSIRT including services they will handle and the scope/region which is covered.

CERT/CSIRT constituency (scope) could be defined/limited to:

- Covers the entire City .
- Is responsible for providing security related solutions to all City employees.
- In collaboration with SOC is responsible for handling Security infrastructure (like Firewall/IDS, etc.) and Security Breach related security incidents in City services and components.

## CERT/CSIRT Stakeholders

---



- Incident Handling and response is not a self contained process.
- Relationship, communication channels, data sharing agreements , policies and procedures must be established across the organization.
- Strong commitment is needed from High Management .
- CERT/CSIRT Manager is the prime actor to work on this specific task.

## Suggested Services

---

- Alert and Warning

CERT/CSIRT responsibilities includes:

- In collaboration with SOC and Risk Team CSERT/CSIRT will collect share all the latest security alerts/information from internet sites with the main goal of:
  - Coordinating with different teams to maintain highest security level at ISMD.
  - Patch Management, Anti Virus Management etc.
  - Trend Analysis for possible emergency scenarios .
  - Problem Management Security Update report.
  - Security Assurance audit reports.

- Vulnerability Handling and Artifact Handling

CERT/CSIRT responsibilities includes:

- In collaboration with Risk Team CSERT/CSIRT will:
  - Identify the relevance of the information to the City ICT.
  - Conduct impact analysis of the identified/reported vulnerability.
  - Gather information about systems vulnerable to identified/reported vulnerability.
  - Support the involved team in implementing controls based on priority.

- Artifact Handling

CERT/CSIRT responsibilities includes:

- Technical examination and analysis of any artifact found on a system.

- Determining the appropriate actions to detect and remove artifacts from a system, as well as actions to prevent future similar issues (this may involve creating signatures that can be added to antivirus software or IDS).
- Coordination and sharing the information collected with other CERT/CSIRT, similar security organization as well as vendors.

- Incident Handling

CERT/CSIRT responsibilities includes:

- Management of emergencies at City ICT.
- Coordination between all the team involved.

The coordination work may involve collecting contact information, notifying subjects of their potential involvement (as victim or source of an attack), collecting statistics about the number of subjects involved, and facilitating information exchange and analysis. Part of the coordination work may involve notification and collaboration with legal department, human resources and/or public relations departments.

It would also include coordination with law enforcement.

- Announcements and Technology watch

CERT/CSIRT responsibilities includes monitor of:

- New technical developments, intruder activities, and related trends to help identify future threats.
- Announcements and Technology watch inform constituents about new developments with medium to long-term impact, in order to allow proactive protection to be enable.
- The outcome of this service might be some type of announcement, guidelines, or recommendations focused at more medium to long-term security issues.

## Bibliography

- Department of Economic and Social Affairs of the United Nations Secretariat. World Economic and Survey 2013 Social Sustainable Development Challenges. Retrieved on 14 of March 2014 from [http://www.un.org/en/development/desa/policy/wess/wess\\_current/wess2013/WESS2013.pdf](http://www.un.org/en/development/desa/policy/wess/wess_current/wess2013/WESS2013.pdf)
- Focus Group on Smart Water Management (FG-SWM), International Telecommunications Union (ITU). Technical Report on Smart Water Management for Smart Sustainable Cities.
- World Bank. Cities & Climate Change Leadership Program. (2013)
- Medellín: the fast track from the slums* The Guardian. Retrieved on 6 of May 2014 from <http://www.theguardian.com/world/2013/jul/31/medellin-colombia-fast-track-slums-escalators>
- The definition is a modification from the definition that appears in <http://www1.worldbank.org/publicsector/anticorrupt/PoliticalEconomy/stakeholderanalysis.htm>
- Introduction to the Logical Framework Approach (LFA) for GEF-financed projects. German Foundation for International Development, Telefonica. Informe Anual. Smart Cities: un primer paso hacia la internet de las cosas.
- Smart Cities Council. Readiness Guide. Retrieved on 13 of March 2014 from <http://smartcitiescouncil.com/resources/smart-cities-readiness-guide>
- Barcelona city hall. Retrieved on 13 of March 2014 from [http://w110.bcn.cat/portal/site/Ajuntament/menuitem.38c1cee3a16e78f040f740f7a2ef8a0c/?vgnextoid=6050142be8ef0310VgnVCM10000074fea8c0RCRD&vgnnextchannel=6050142be8ef0310VgnVCM10000074fea8c0RCRD&lang=ca\\_ES](http://w110.bcn.cat/portal/site/Ajuntament/menuitem.38c1cee3a16e78f040f740f7a2ef8a0c/?vgnextoid=6050142be8ef0310VgnVCM10000074fea8c0RCRD&vgnnextchannel=6050142be8ef0310VgnVCM10000074fea8c0RCRD&lang=ca_ES)
- City of London. About the City. Retrieved on 13 of March 2014 from <http://www.cityoflondon.gov.uk/about-the-city/who-we-are/Pages/organisational-structure.aspx>
- City of Chicago. Departments. Retrieved on 13 of March 2014 from <http://www.cityofchicago.org/city/en/depts.html>
- City of Boston. Retrieved on 18 of March 2014 from <https://www.cityofboston.gov/government/citydept.asp>
- Rio de Janeiro. Órgãos municipais. Retrieved on 13 of March 2014 from <http://www.rio.rj.gov.br/orgaos-municipais;jsessionid=D0DA80C05219FFC60C4BA14200A12F71.liferay-inst5>
- Ciudad de Méjico DF. Retrieved on 13 of March 2014 from <http://www.df.gob.mx/index.php>
- Santiago de Chile. Oficinas Municipales. Retrieved on 13 of March 2014 from <http://www.municipalidaddesantiago.cl/categorias/home/municipio-2/oficinas-municipales>
- Covenant of Mayors. Last accessed 19 of March 2014 [http://www.covenantofmayors.eu/index\\_en.html](http://www.covenantofmayors.eu/index_en.html)
- Energy Cities. Last accessed 19 of March 2014, <http://www.energy-cities.eu/>
- Smart Cities Stakeholders Platform – European Commission. Retrieved on 19 of March 2014 from <http://eu-smartcities.eu/>



- Asociación Iberoamericana de Centros de Investigación y Empresas de Telecomunicaciones (ACHIET) Retrieved on 19 of March 2014 from <http://ahciet.net/index.php/ahciet/quienes-somos>
- Encuentro Iberoamericano de Ciudades Digitales. Retrieved on 19 of March 2014 from <http://www.ciudadesdigitales2013.com/>
- GSMA Smart Cities initiative. Retrieved on 19 of March 2014 from <http://www.gsma.com/connectedliving/smart-cities/>
- Smart Cities Council. Retrieved on 19 of March 2014 <http://smartcitiescouncil.com/category-vision>
- Master in Smart Cities. University of Girona. Last accessed 21 of March 2014 <http://www.udg.edu/tabid/8439/Default.aspx?ID=3105M0413&language=en-US&IDE=5>
- Master in City Sciences. Universidad Politécnica de Madrid. Last accessed 21 of March 2014. <http://www.citysciences.com>
- Smart Cities courses at CASA. University College London. Last accessed 21 of March 2014. <http://mscsmartcities.org/>
- Santa Fe Institute. Cities, Scaling and Sustainability. Last accessed 24 of March 2014. <http://www.santafe.edu/research/cities-scaling-and-sustainability/>
- Senseable Cities Lab. Massachusetts Institute of Technology (USA). Last accessed 21 of March 2014. <http://senseable.mit.edu/>
- Smart city Lab. University of Bologna (Italy). Last accessed 21 of March 2014. <http://smartcity.csr.unibo.it/>
- Working group 2 from the Focus Group on Smart Sustainable Cities (FG-SSC) International Telecommunications Union. Overview and Role of ICT in Smart Sustainable Cities. Technical Report.
- Street Bump. Last accessed 12 of March 2014. <http://streetbump.org/about>
- Repara Ciudad. Last accessed 12 of March 2014. <http://reparaciudad.com/>
- Smart Citizen Kit. Last accessed 12 of March 2014. <http://smartcitizen.me/pages/sck>
- ISO Focus Magazine. Volume 4, No. 1, January 2013, ISSN 2226-1095. Retrieved on 11 of March 2014. [http://www.iso.org/iso/home/news\\_index/iso\\_magazines/isofocusplus\\_index/isofocusplus\\_2013/isofocusplus\\_2013-01.htm](http://www.iso.org/iso/home/news_index/iso_magazines/isofocusplus_index/isofocusplus_2013/isofocusplus_2013-01.htm)
- Street Bump. Retrieved on 18 of March 2014. <http://streetbump.org/about>
- Repara Ciudad. Retrieved on 18 of March 2014. <http://reparaciudad.com/>
- Smart Citizen Kit. Retrieved on 18 of March 2014. <http://smartcitizen.me/pages/sck>
- The Stakeholder Engagement Manual Volume 1: The Guide to Practitioners Perspectives on Stakeholder Engagement Volume 1
- Strengthening UNEP's Legitimacy: Towards Greater Stakeholder Engagement. United Nations Environment Programme
- Guidelines on Stakeholder Engagement in REDD+Readiness with a Focus on the Participation of the Indigenous People and Other Forest Dependent Communities.
- Stakeholder Engagement: A Road Map to Meaningful Engagement: How to do Corporate Responsibility Series.









Exploring the  
Smart Sustainable  
City Infrastructure

3





# 3.1

## Overview of smart sustainable cities infrastructure



## Acknowledgements

This Technical Report was researched and written by Roberto Ortiz, Wilmer Narvaez and Wilmer Azurza (Ministry of Transportation and Communications, Peru), with support from Ziqin Sang (Fiber Home Technologies), Paolo Gemma (Huawei) and Leonidas Anthopoulos (Technological Education Institute of Thessaly), as a contribution to ITU-T Focus Group on Smart Sustainable Cities (FG-SSC).

Special thanks to Wilmer Narvaez, Fiorella Moschella, Abel Mellado, Wilmer Azurza (Ministry of Transportation and Communications, Peru) for their helpful review and contribution.

Additional information and materials relating to this report can be found at: [www.itu.int/itu-t/climatechange](http://www.itu.int/itu-t/climatechange). If you would like to provide any additional information, please contact Cristina Bueti at [tsbsg5@itu.int](mailto:tsbsg5@itu.int).

## Table of Contents

		Page
<b>1</b>	<b>Introduction .....</b>	<b>220</b>
1.1	Background.....	220
1.2	Stakeholders in SSC .....	220
1.3	Architecture of a Smart Sustainable City .....	221
<b>2</b>	<b>Digital/ICT infrastructure for SSC .....</b>	<b>225</b>
2.1	Network facilities.....	225
2.2	ICT facilities: over the top, services, applications and contents .....	246
2.3	Terminals, Sensing and multi-device layer .....	250
2.4	Energy efficiency of ICT infrastructure .....	270
2.5	Example of designing an open access network for smart cities .....	276
2.6	Adaptation to Climate Change effect.....	284
<b>3</b>	<b>Physical infrastructure and its intelligent upgrading .....</b>	<b>287</b>
3.1	Energy and water.....	287
3.2	Transportation.....	298
3.3	Healthcare .....	305
3.4	Public safety and emergency.....	306
3.5	Education and tourism .....	317
3.6	Environment and waste management.....	317
3.7	Smart building, digital home .....	318
<b>4</b>	<b>Planning the national deployment of ICT infrastructure for SSC .....</b>	<b>322</b>
4.1	Urban growth in the knowledge era and the digital divide .....	325
4.2	Strategies for the deployment of digital/ICT infrastructure .....	326
4.3	Evolution to become a Smart Sustainable City .....	329
	<b>Annex A – Abbreviations .....</b>	<b>330</b>
	<b>Appendix I – Bibliography .....</b>	<b>335</b>

GPS coordinates

N60°33.858' E30° 45.258'

Donec pede justo, fringilla vel, aliquet nec, vulputate eget, arcu.

Donec pede justo, fringilla vel, aliquet nec, vulputate eget, arcu.



## Overview of smart sustainable cities infrastructure

### Executive Summary

The goal of this report is to provide a technical overview on infrastructure related to information and communications technology (ICT) and specifically, to develop smart sustainable cities (SSC). This document is divided into five sections.

The world is facing a structural change process associated with the development and application of the ICT. ICT have the capacity to provide intelligence to traditional infrastructure, turning it into a smart infrastructure. Here, it is important to note that traditional infrastructures also facilitate the deployment of communications networks.

This development and innovation in the ICT sector along with its potential to upgrade traditional infrastructure, enables the construction of SSC as envisioned by ITU. According to research conducted by FG-SSC, there are multiple stakeholders who can contribute meaningfully to the establishment of SSC in the future. These stakeholders are actively involved in the development and deployment of the required infrastructure for SSC.

This document on SSC infrastructure elaborates on the architecture of SSC. The architecture of SSC is divided into four layers namely: sensing, communication, data and application layer. For the digital infrastructure of SSC, there are different telecommunications networks required for data centers, specialized software, sensors etc.

While planning the national deployment of ICT infrastructure, there are two aspects to be considered. First is the deployment of new ICT infrastructure and second is the improvement of the current infrastructure. These deployment strategies should focus on boosting both supply and demand.

As mentioned in this document, evolution to SSC may start from varying degrees of urbanization (depending on the current development of each urban area. Existing cities which have embarked on the SSC journey, can help other upcoming cities by providing with valuable lessons to be learnt for the SSC transition.

# 1 Introduction

---

## 1.1 Background

There are several definitions of a city. A city can be classified according to its population density and its level of urbanization. Both variables are related to the human intervention over a populated area. Those areas with high population density appear to be the most heavily modified when compared with their original landscapes. This reflects the intensity of human activities which have taken place in the area. However, defining a city only from a statistical point of view can be misleading.

From an economic point of view, the emergence of agglomeration economies causes an increase in productivity and efficiency in a city. Meanwhile, it reduces transportation and communications costs, stimulates the labor division and promotes the development of economies of scale and increasing returns to scale. These agglomeration economies partially explain the process of urbanization, since people move to cities when companies move business there. Historically, this process has been associated with two major structural changes; firstly, the development of the agricultural and industrial sectors and secondly, the expansion of the services sector.

Nowadays, the world is facing a third structural advancement with the development and application of the information and communications technology (ICT). In accordance with this development, there have been several novel concepts for cities based on ICT. The reputed sociologist, Manuel Castells, an influential thinker on the changes caused by ICT, developed the idea of an Informational City. This concept is related to the communication flows among a city.

It is important to recognize that in order to be part of this ICT based metamorphosis, cities need to incorporate infrastructures that have the capacity to utilize the potential of ICT and combine them with the existing infrastructure (such as building, roads, etc.). For this reason, the "convergence" ICT idea is applied to the infrastructure for "Smart Sustainable Cities (SSC)". For instance, electricity networks serve as routes outlined to telecommunications transport networks (which also develops with better control on the electrical system using SCADA systems). The use of buildings for the installation of raised elements such as antennas and base stations is also required.

Therefore, ICT acts as an enabler to construct SSC with it is intelligent and efficient use of resources being the focus. Consequently using ICTs in SSC results in cost and energy saving, increased economic growth, improved quality of life (QoL), and reduced environmental footprint.

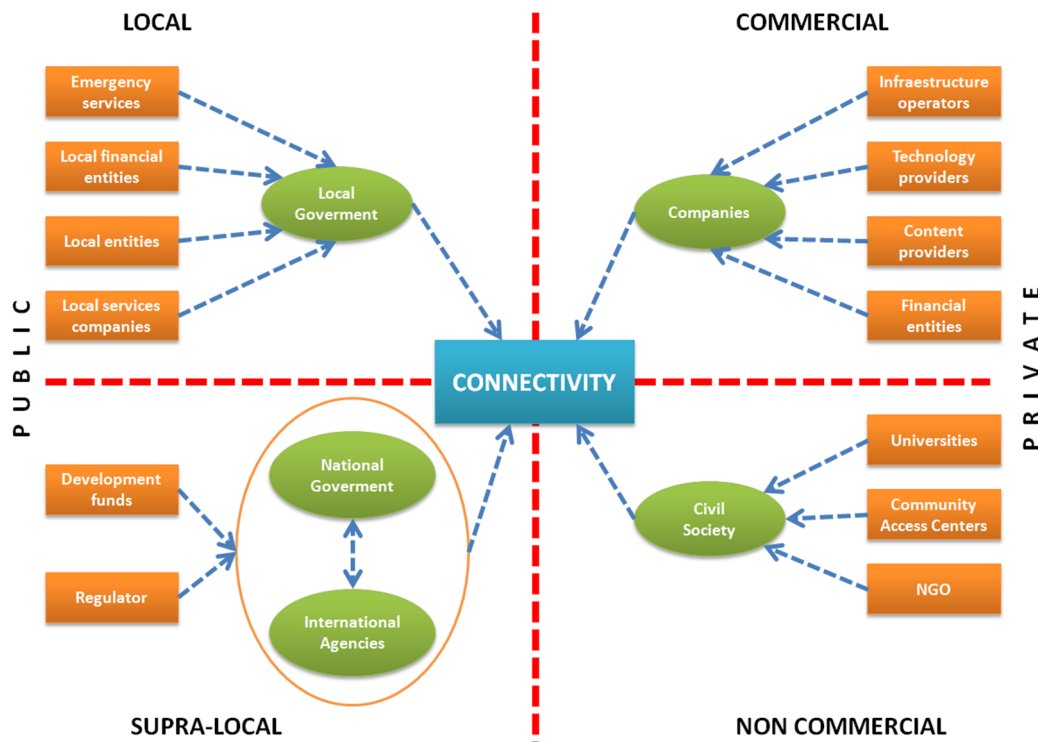
A definition of Smart Sustainable Cities is available in deliverable SSC-0146 "Agreed definition of a Smart Sustainable City" of this focus group.

## 1.2 Stakeholders in SSC

Stakeholders refer to the major players involved in SSC establishment and functioning. The classification of these stakeholders is diverse. In particular, the classification of interdependent and standalone stakeholders distinguishes public and private institutions, local and supra-local entities, as well as commercial and non-commercial entities. The following diagram<sup>1</sup> shows an example of the interrelationships between some key stakeholders.

---

<sup>1</sup> Adapted from "Broadband and Local Government: evaluation of experiences and recommendations". United Nations (CEPAL). September 2007



**Figure 1 – Relationship between key stakeholders**

Source: Ministry of Transportation and Communications of Peru

All these actors (and other identifiable ones) will have interests linked to the idea of "Smart Sustainable City" in order to:

- Improve the quality of the citizens' life.
- Ensure sustainable economic growth to provide a better standard of life and employment opportunities for the citizens.
- Improve the welfare of the citizens, which means improving the quality of medical care, welfare, physical safety, and education, among others.
- Establish and implement a responsible and sustainable approach to environmental management.
- Strengthen prevention and management of natural disasters, including the ability to reduce the impacts of climate change.
- Provide an effective mechanism for regulatory compliance and well balanced governance, with policies and standardized processes.

A detailed analysis of stakeholders is available in the Technical Report on Setting the Stage for Stakeholders' Engagement in Smart Sustainable Cities.

### 1.3 Architecture of a Smart Sustainable City

The architecture of SSC has been defined in the corresponding FG-SSC Technical Specifications on "Setting the framework for an ICT architecture of a smart sustainable city",

At a high level, a Meta-Architecture consists of five layers as depicted in Figure 2.



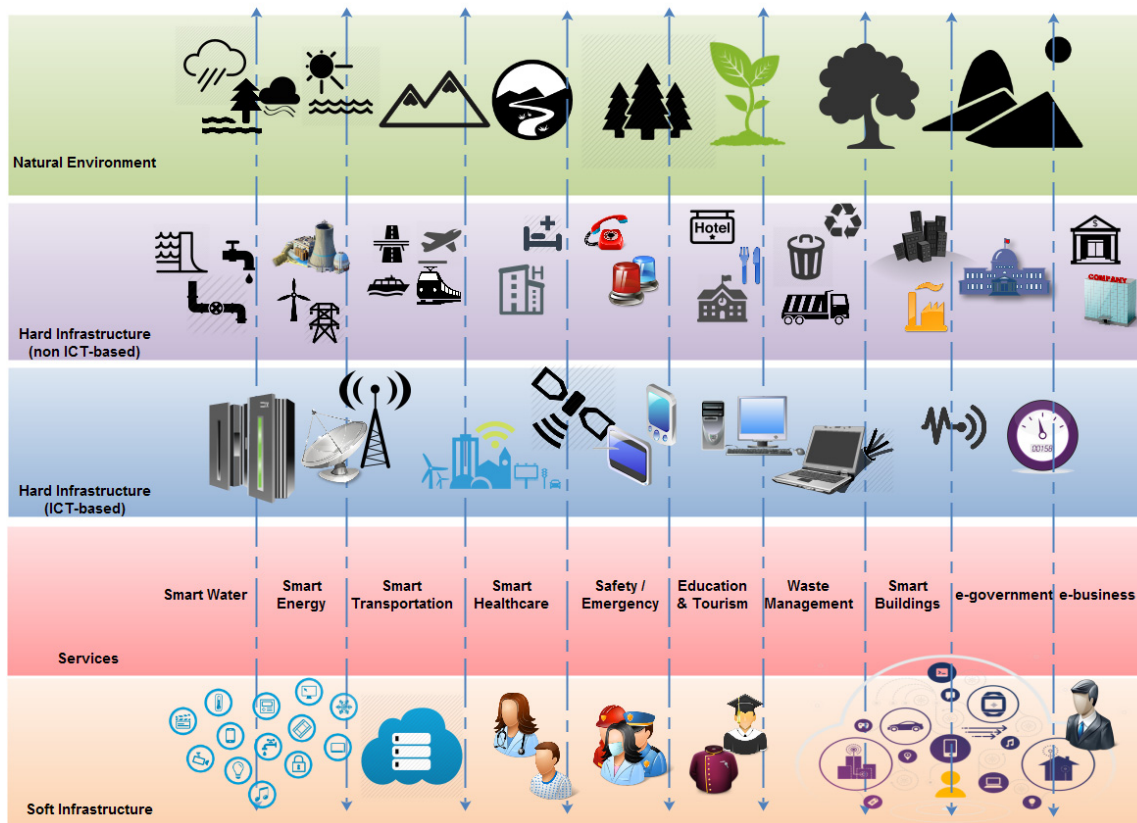


Figure 2 – Multi-tier SSC ICT meta-architecture<sup>2</sup>

A smart sustainable city can be also considered a system comprising subsystems and, its ICT architecture (as depicted in Figure 3), where each subsystem addresses a different smart sustainable city service category. Finally, with regard to its technical definition, it has been seen from different views. Figures 4 and 5 demonstrate the communication view of the SSC ICT architecture, from a physical and an information flow perspective respectively. Please note that both perspectives of this view are multi-tier.



Figure 3 – Subsystems of SSC ICT architecture<sup>2</sup>

<sup>2</sup> According to Technical Specifications on “Setting the framework for an ICT architecture of a smart sustainable city”.

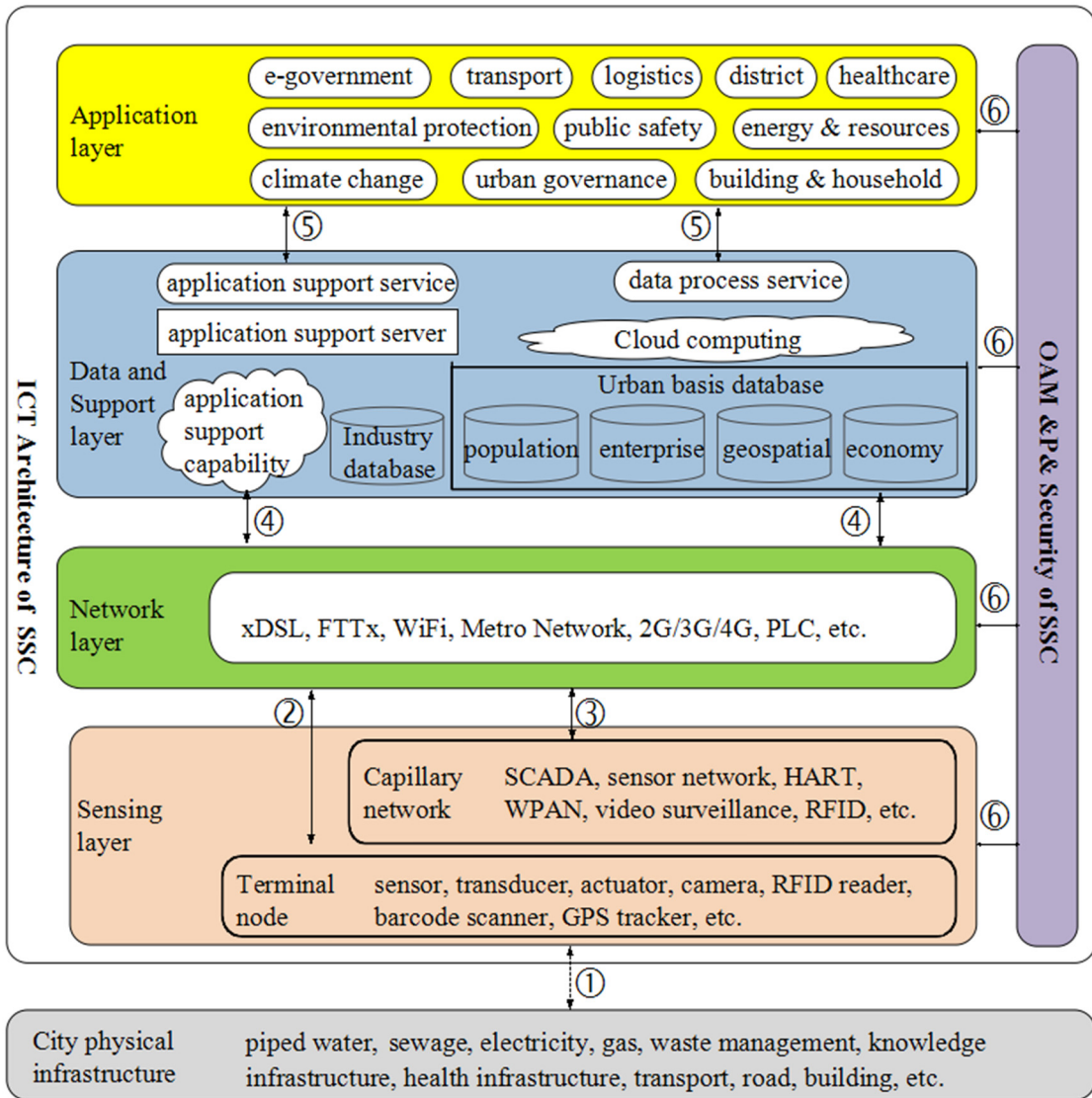
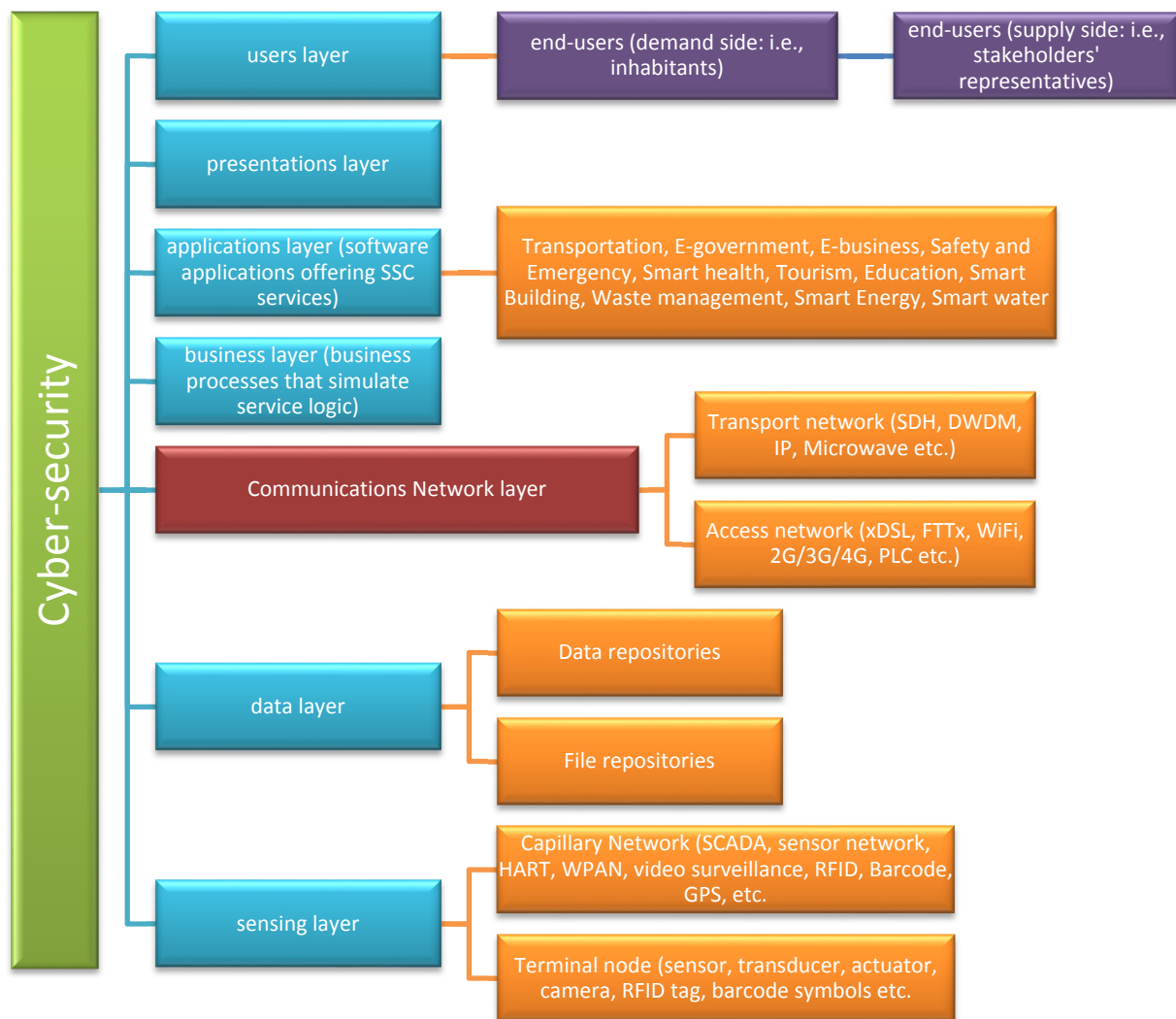


Figure 4 – A multi-tier SSC ICT architecture from communication view, (physical perspective)



**Figure 5 – A multi-tier SSC ICT architecture from communications view, (information flow perspective)**

Both these perspectives concern valid representations of the same architecture, one closer to the language of infrastructure developer the second more in line with the context required for information system developers. The architecture consists of the following layers (illustrated in Figure 4.):

- **Sensing layer:** This layer consists of a terminal node and capillary network. Terminals (sensor, transducer, actuator, camera, RFID reader, barcode symbols, GPS tracker, etc.) are capable of sensing the physical world. They provide the superior “environment-detecting” ability and intelligence for monitoring and controlling the physical infrastructure within the city. The capillary network (including SCADA, sensor network, HART, WPAN, video surveillance, RFID, GPS related network etc.) connects various terminals to the network layer, providing ubiquitous and omnipotent information and data.
- **Network layer:** The network layer indicates various networks provided by telecommunication operators, as well as other metro networks provided by city stakeholders and/or enterprise private communication network. It is the “infobahn”, the network layer data and support layer: The data and support layer makes the city “smarter”. Its main purpose is to ensure the support capabilities of various city-level applications and services. Data and support layer contain data

centers from industries, departments, enterprises, as well as the municipal dynamic data center and data warehouse, established for the realization of data processing and application support.

- Application layer: This layer includes various applications that manage SSC and deliver the SSC services.
- Operation Automation Monitoring & Protection & security framework: this framework provides the operation, administration, maintenance, provisioning, and security function for the ICT systems of SSC.

Figure 4 respect to figure 5 utilize also the following layers:

- Users layer: it organizes SSC service end-users into groups from both the demand and the supply sides;
- Presentations layer: it contains the user interfaces (web, Apps, voice commands etc.), which stand between end-users and SSC services;
- Applications layer: it contains all corresponding software applications that realize the SSC services;
- Business layer: it consists of the business processes, which lie behind each SSC service execution;
- Communications layer: it contains the above mentioned networks, over which the SSC services are performed and transactions and data flow are realized;
- Data layer: it contains the data and file repositories, where data are created or retrieved;
- Sensing layer: this consists of terminal node and capillary network. The terminals (sensor, transducer, actuator, camera, RFID tag, barcode symbols etc.) sense the natural environment where the smart sustainable city is located and the corresponding hard infrastructure and utilities (water, transport etc.). It provides the superior 'environment-detecting' ability and intelligence for monitoring and controlling the physical infrastructure within the city. The capillary network connects various terminals to communication layer, or directly to data layer and/or application layer providing ubiquitous and omnipotent information and data.

The detailed discussions on ICT Architecture and Architecture Framework, as well as security aspect of Smart Sustainable Cities is available in deliverables SSC-0345 "Setting the framework for an ICT architecture of a smart sustainable city" and SSC-0090-rev3 "Technical Report on ICT Infrastructure for Cyber-Security, Data Protection & Resilience" respectively of this focus group.

## 2 Digital/ICT infrastructure for SSC

---

ICT infrastructure plays a crucial role in all SSC subsystems (Figure 3) and they deliver the SSC services, which were presented in SSC meta-architecture (Figure 2). This section demonstrates technical aspects with regard to the ICT Infrastructure, which is utilized in the SSC ICT architecture.

### 2.1 Network facilities

The network services describe both data and communications layers depicted Figures 4 and 5.

#### 2.1.1 Data layer

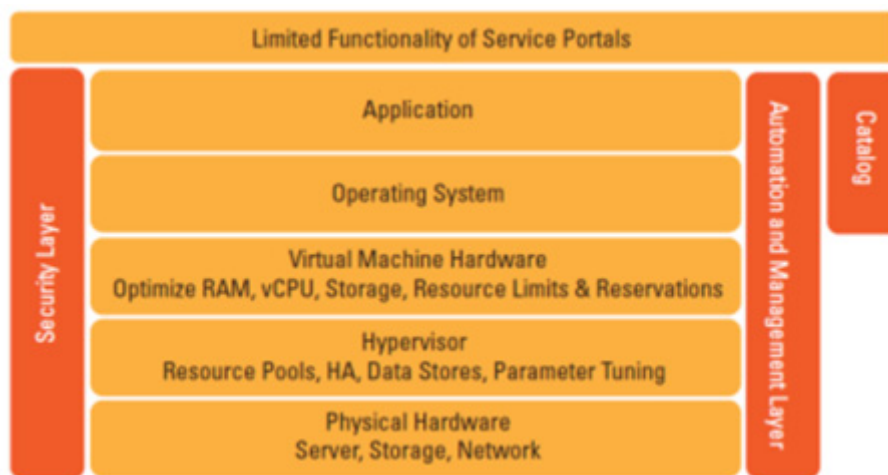
The Data Layer concerns, the distributed nodes that require intelligent management and are integrated into the network. This layer has components that are described in the following subsections.

### 2.1.1.1 Data/content center

These are centralized repositories, for the storage, management, and dissemination of data and information organized around the objective of creating SCC. It is recommended that data warehouses use a platform that is scalable, reliable and high performance that allows for growth as the number of sensors installed is increased in the territory or/and the city.

### 2.1.1.2 Data center characteristics and the evolution of infrastructure architecture

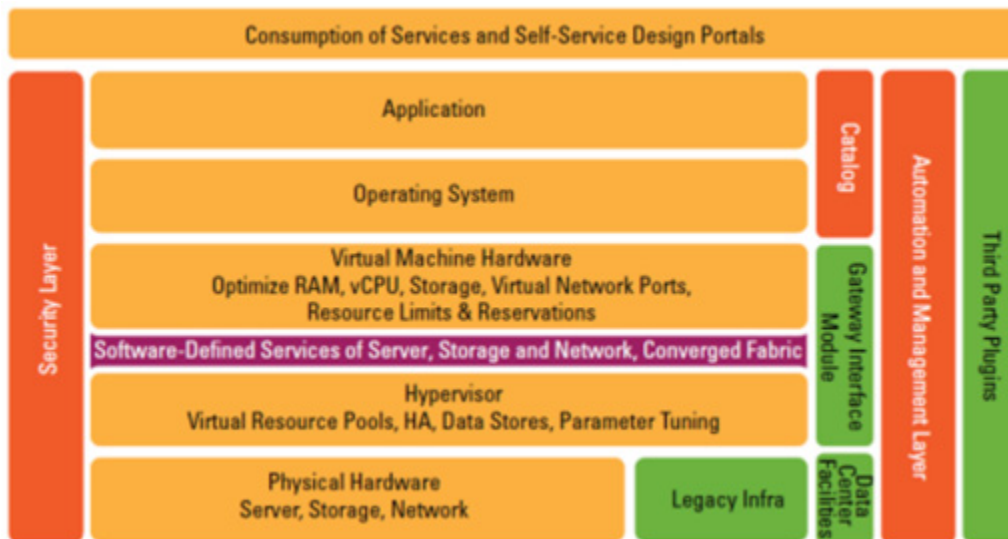
The infrastructure must be designed and provisioned including the specific volumetric considerations for supporting the business applications and considering the peak load transaction in jobs per second, availability and scalability requirements. When volumetric and projected growth do not manifest as envisaged, this method of sizing infrastructure computation and storage could lead to either undersizing or oversizing the footprint. Often, having such islands of computer infrastructure and storage, leads to underutilization of resources. This has a cascading effect on investment and effort spent on energy consumption, management overheads, software licenses and data center costs.



**Figure 6 – Data center infrastructure architecture: a conceptual view**

Figure 6 depicts a conceptual view of today's infrastructure architecture in a traditional data center. The surrounding data center components such as data centers facilities and legacy infrastructure would exist in this case, as individual components in the data center.





**Figure 7 – Legacy infrastructure surrounding software-defined data center: a conceptual view**

Figure 7 illustrates the infrastructure architecture surrounding Software-Defined Data Center (SDDC)<sup>3</sup>, where software is deployed to meet applications for dynamic workloads. SDDC blocks need to be holistic for integration across physical, legacy and data centers facilities. This requires third-party vendors with plug-ins to provide the interfaces.

Based on the previous figure, the following aspects can be emphasized on:

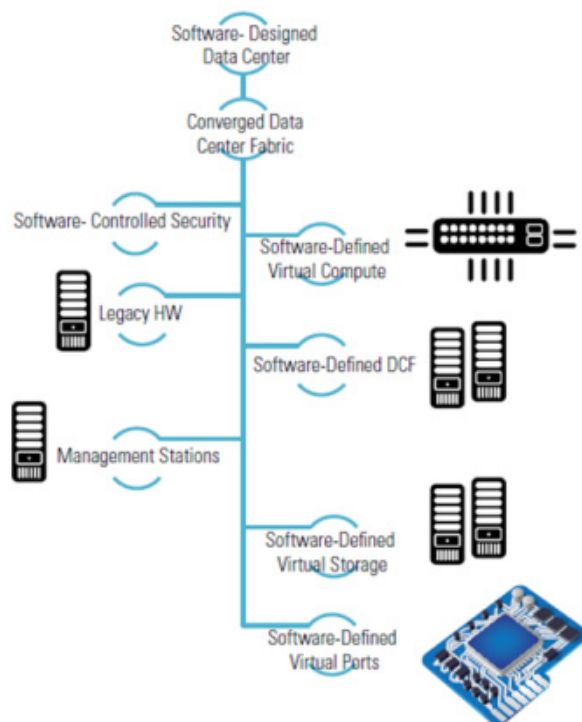
- Physical hardware and legacy infrastructure:
  - This constitutes the bare metal hardware and data centers that can be virtualized across physical or legacy systems. The ability of these to be involved and controlled via software, programmatically, will be based on the evolution of technology or business needs, depending on the abstraction of server, storage, network components and legacy integration requirements. Original equipment manufacturing (OEMs)<sup>4</sup> and converged infrastructure vendors are key players since they design, fabricate and integrate to make this happen.
- Automation and Management layer:
  - This consists of an integrated suite of management and monitoring solutions for the data center estate, comprising operations and performance engineering capabilities.
- Gateway interface module:
  - For SDDCs to be mainstream, they must be integrated with existing data centers components. This gateway module will comprise of multi-vendor OEM plug-ins connecting with the existing data center footprint. OEM partners and service system integrators need to drive this.

<sup>3</sup> The term SDDC, or software-defined data center, was coined in 2012 by VMware's former chief technology officer (CTO), Dr. Steve Herrod. At first, it may seem unusual to define a data center in terms of software, rather than hardware infrastructure that programmatically turns on and off devices, or shrinks and expands computing resource consumption as business requirements dictate.

<sup>4</sup> Original equipment manufacturing (OEM).



The following figure shows a logical depiction of SDDC to explain the challenges foreseen in mainstream adoption.



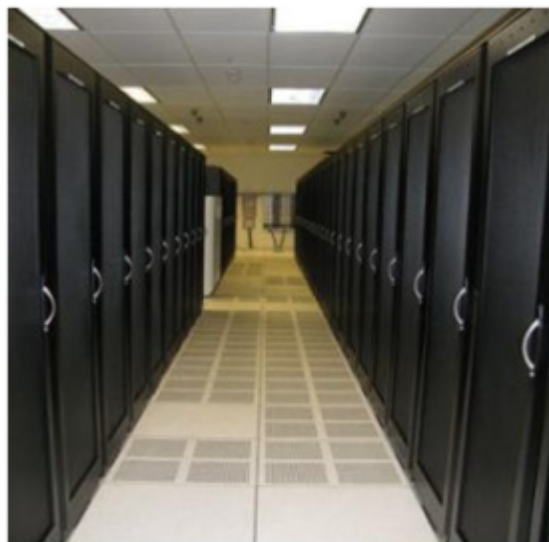
**Figure 8 – A logical view of future SDDC**

For a data center, the facilities play an important role in ensuring that the SLAs are aligned and met. Given the mix of data center categories in use (such as tier 1, 2, 3 or 4, with tier 4 data centers built for maximum resiliency and uptime), data centers providers must develop integrated and adaptable power and cooling solutions in line with the infrastructure capacity planned and provisioned.

### 2.1.1.3 Design considerations of data center

A data center is a facility used to house computer systems and associated components, such as telecommunications and storage systems. It generally includes redundant or backup power supplies, redundant data communications connections, environmental controls (e.g., air conditioning, fire suppression) and various security devices.

A data center can occupy one room of a building, one or more floors, or an entire building itself. Most of the equipment is often in the form of servers mounted in 19 inch rack cabinets, which are usually placed in single rows forming corridors (so-called aisles) between them. This allows people access to the front and rear of each cabinet. Servers differ greatly in size from 1U servers to large freestanding storage silos which occupy many square feet of floor space. Some equipment such as mainframe computers and storage devices are often as big as the racks themselves, and are placed alongside them. Very large data centers may use shipping containers packed with 1,000 or more servers each. When repairs or upgrades are needed, whole containers are replaced (rather than repairing individual servers).



**Figure 9 – Cabinet aisle in a data center**

#### **2.1.1.4 Technology infrastructure design**

Technology infrastructure design addresses the telecommunications cabling systems that run throughout data centers. There are cabling systems for all data centers environments, including horizontal cabling, voice, modem, and facsimile telecommunications services, premises switching equipment, computer and telecommunications management connections, keyboard/video/mouse connections and data communications. Wide area, local area, and storage area networks should link with other building signaling systems (e.g., fire, security, power, HVAC, EMS).



**Figure 10 – Under floor cable runs**

#### **2.1.1.5 Electrical power**

A bank of batteries in a large data center, used to provide power until diesel generators can start backup power, consists of one or more uninterruptible power supplies including battery banks, and/or diesel/gas turbine generators.

To prevent single points of failure, all elements of the electrical systems, including backup systems, are typically fully duplicated, and critical servers are connected to both the "A-side" and "B-side" power feeds. This arrangement is often made to achieve N+1 redundancy in the systems. Static transfer switches are sometimes used to ensure instantaneous switchover from one supply to the other in the event of a power failure.



**Figure 11 – Bank of batteries**

#### **2.1.1.6 Network infrastructure**

Communications in data centers today are most often based on networks running the IP protocol suite. Data centers contain a set of routers and switches that transport traffic between the servers and to the outside world. Redundancy of the Internet connection is often provided by using two or more upstream service providers as Multihoming. Multihoming refers to a computer or device connected to more than one computer network. It can be used, for example, to increase the reliability of an Internet Protocol network, such as a user served by more than one Internet service provider. Also SAN solutions are recommended for redundant storage management.

Some of the servers at the data center are used for running the basic internet and intranet services needed by internal users in the organization, e.g., e-mail servers, proxy servers, and DNS servers.

Network security elements are also usually deployed: firewalls, VPN gateways, intrusion detection systems, IPS (Intrusion Prevention System) is also widely used. Monitoring systems for the network and some of the applications are also common. Additional off site monitoring systems are also typical, in case of a failure of communications inside the data center.



**Figure 12 – Rack mounted servers**

#### **2.1.1.7 Environmental control**

The physical environment of a data center must be rigorously controlled. Air conditioning is used to control the temperature and humidity in the data center. Some guidelines recommend a temperature range of 18–27 °C (64–81 °F), a few point range of 5–15 °C (41–59 °F), and a maximum relative humidity of 60% for data centers environments. The temperature in a data center will naturally rise because the electrical power used heats the air. Unless the heat is removed, the ambient temperature will rise, resulting in malfunctioning of the electronic equipment. By controlling the air temperature, the server components at the board level are kept within the manufacturer's specified temperature/humidity range. Air conditioning systems help control humidity by cooling the return space air below the dew point. Too much humidity and water may begin to condense on internal components. In case of a dry atmosphere, ancillary humidification systems may add water vapour if the humidity is too low, which can result in static electricity discharge problems which may damage components. Subterranean data centers may keep computer equipment cool while expending less energy than conventional designs.



**Figure 13 – Air conditioning equipment**

#### 2.1.1.8 Power saving system control technology to maintain temperature and humidity of container-type data centers<sup>5</sup>

Power saving system control technology shall be included to maintain temperature and humidity of container-type data centers by closely coordinating the operation of servers and air-conditioning systems as elemental technology for ICT infrastructure of smart sustainable cities.

Data centers are used in smart sustainable cities in order to collect necessary data, process those data and provide and manage application services using them.

With container-type data centers rather than data centers in buildings, one can expand the scale of data centers according to increases in demand. It facilitates the achievement of a balance between investment and return for data centers providers as well as a reduction of environmental burden.

To reduce the environmental burden of the container-type data centers themselves, the technology is required to reduce the amount of electricity consumed to maintain proper temperature and humidity levels.

There is technology that maintains temperature and humidity of container-type data centers using external ambient air and air-conditioning equipment attached to the inside of the container, instead of an internal fan equipped to each server. The use of external ambient air reduces the amount of electricity used by the air conditioning.

By eliminating the use of internal fans of servers, the amount of electricity used by air conditioning is also reduced. Generally speaking, when external ambient air is used to cool servers, the higher the ambient temperature is, the larger the amount of electricity consumption of internal fans becomes. However, this technology allows the use of internal fans by maintaining temperature and humidity with air-conditioning equipment attached to inside of the container.

The main composing elements of the air-conditioning equipment attached to inside of the container are the fans. They are controlled to achieve optimum temperature of CPUs using information of location, temperature and electricity consumption of each CPU.

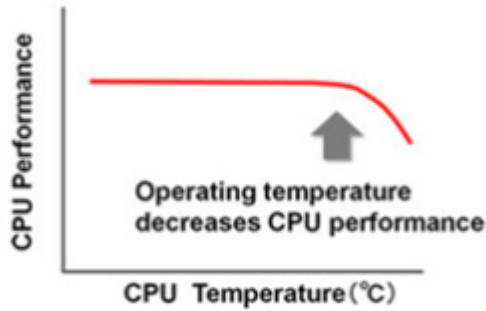
If the temperature of each CPU is too high, the performance of the CPU gets lower (Figure 14). The technology controls the container air-conditioning fan to ensure that the system never reaches an operating temperature where CPU performance is compromised.

In addition, there is optimum temperature of CPU to minimize the total power consumption (Figure 15). When a CPU's operating temperature becomes too high, the amount of electricity consumed by a server increases as a result of the impact of the CPU's leakage current. Conversely, by trying to lower the CPU temperature, greater power is consumed by the container air-conditioning fan. The technology controls the container air-conditioning fan to achieve an optimal CPU temperature that will enable the amount of power consumed by the entire container data centers to be minimized.

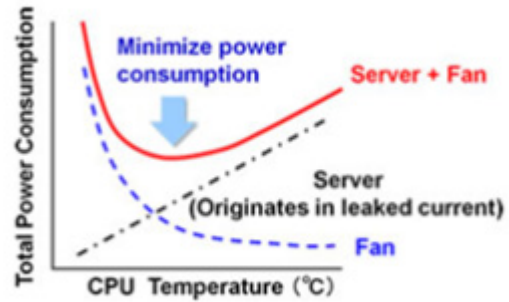
---

<sup>5</sup> Corresponds to a contribution of FUJITSU (Japan) by document FG-SSC-0031.





**Figure 14 – Control technology to prevent decreased CPU performance**



**Figure 15 – Control technology to minimize overall energy consumption**

Source Fujitsu (2012) Fujitsu develops power saving system control technology for container data centers<sup>6</sup>

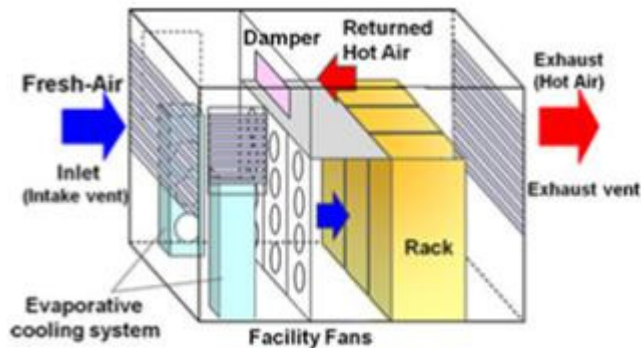
When the external temperature is between 10°C and 35°C, the container's air conditioning fan takes air through the external intake vent and moves it inside the racks. The warm air from inside the racks is then released from the exhaust vent.

When the external temperature exceeds 35°C, an evaporative cooling system cools the air to 35°C or lower before moving it with the fan. This ensures that the temperature of the moving air into the racks does not exceed the favorite range of temperature for servers.

Conversely, when the outside temperature is below 10°C, warm air being released from the racks is passed through a damper and returned to the air intake vent side where it is warmed to 10°C or higher before being moved into the racks by the fan. This prevents dew condensation.



**Figure 16 – Prototype container data center**



**Figure 17 – Container data center contents**

Figure 16 is a photo of a prototype container data center and Figure 17 is a schematic of the container's contents.

The effect of reduction of electricity consumption with the prototype container data center was as depicted in Figure 18. It shows that energy consumption is reduced by approximately 40% compared with conventional container data center using internal fans equipped to servers.

<sup>6</sup> <http://www.fujitsu.com/global/news/pr/archives/month/2012/20120404-02.html>



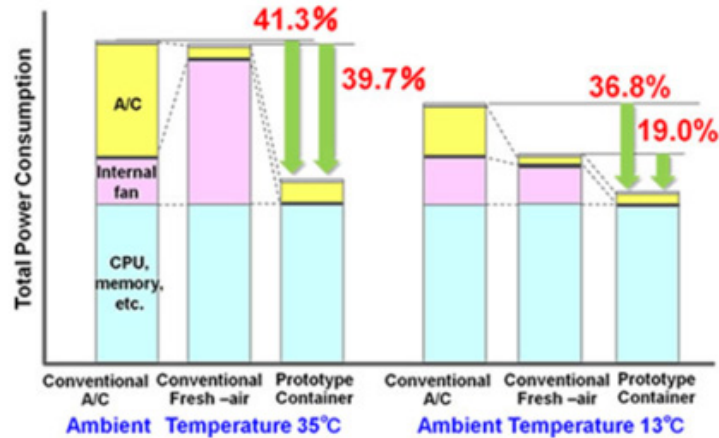


Figure 18 – Power reduction effectiveness

2.1.1.9 Requirements of the technology

(i) To be able to reduce the overall power consumption

PUE (Power Usage Effectiveness) is often used as an indicator to measure the energy effectiveness of air-conditioning of data centers. PUE is the ratio between power consumption of overall data center and that of ICT equipment in the data center. If the figure of PUE gets lower, it means the effectiveness improves. As electricity consumption for internal fans is counted as that of ICT equipment, the larger the internal fans are, the smaller PUE is and the better the energy effectiveness. In contrast to this, it is required to reduce the overall power consumption of data centers, not to limit to lower PUE values.

(ii) To be able to use regardless of climate conditions

Temperature or humidity of external ambient air varies according to locations and seasons. It is required to be able to reduce power consumption in a wide range of temperatures and humidity levels.

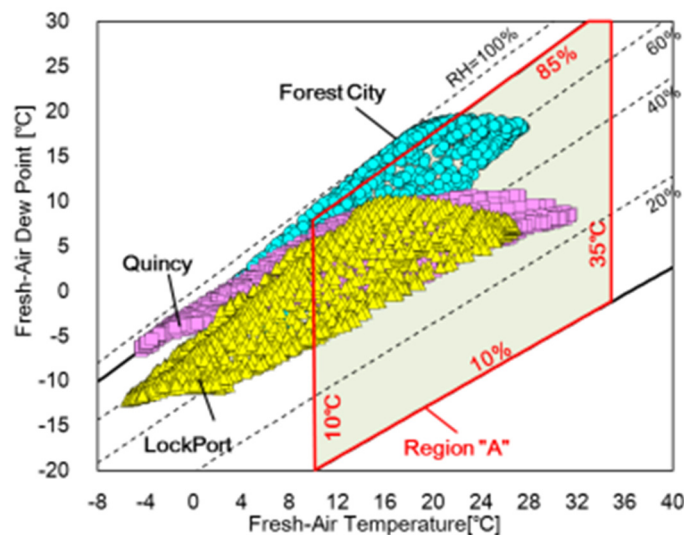


Figure 19 – Hourly climate data for 2010 observed at locations of direct fresh-air-cooled data centers

Source: Hiroshi Endo et.al. (2013). Effect of climatic conditions on energy consumption in direct fresh-air container data centers; IEEE.

#### 2.1.1.10 Data center infrastructure management

Data Center Infrastructure Management (DCIM) is the integration of Information and Communication technology (ICT) and facility management disciplines to centralize monitoring, management and intelligent capacity planning of a data center's critical systems. Achieved through the implementation of specialized software, hardware and sensors; DCIM enables common, real-time monitoring and management platform for all interdependent systems across IT and facility infrastructures.

Depending on the type of implementation, DCIM products can help data centers managers identify and eliminate sources of risk to increase availability of critical IT systems. DCIM products also can be used to identify interdependencies between facility and IT infrastructures to alert the facility manager to gaps in system redundancy, and provide dynamic, holistic benchmarks on power consumption and efficiency to measure the effectiveness of "green IT" initiatives.

Measuring and understanding important data centers efficiency metrics. A lot of the discussion in this area has focused on energy issues, but other metrics can give a more detailed picture of the data centers operations. Server, storage, and staff utilization metrics can contribute to a more complete view of an enterprise data centers. In many cases, disc capacity goes unused and in many instances the organizations run their servers at 20% utilization or less. More effective automation tools can also improve the number of servers or virtual machines that a single admin can handle.

The Recommendation ITU-T L.1300 "Best practices for green data centers", recommended a possible methodology for cooling data centers with high density ICT devices.

Recommendation ITU-T L.1300 describes best practices aimed at reducing the negative impact of data centers on the climate. It is commonly recognized that data centers will have an ever-increasing impact on the environment in the future. The application of the best practices defined in this Recommendation can help owners and managers to build future data centers, or improve existing ones, to operate in an environmentally responsible manner. Such considerations will strongly contribute to a reduction in the impact of the Information and Communication Technology (ICT) sector on climate change.

#### 2.1.2 Communication layer

This is one of the main aspects of the ICT infrastructure. Particular attention should be paid in both the national and urban infrastructure, since the backhuls will feed the backbones that are bound to the international links. Access networks are key for the development of SSC. However they are issues related the deployment of antennas which pose problems in setting up access networks.

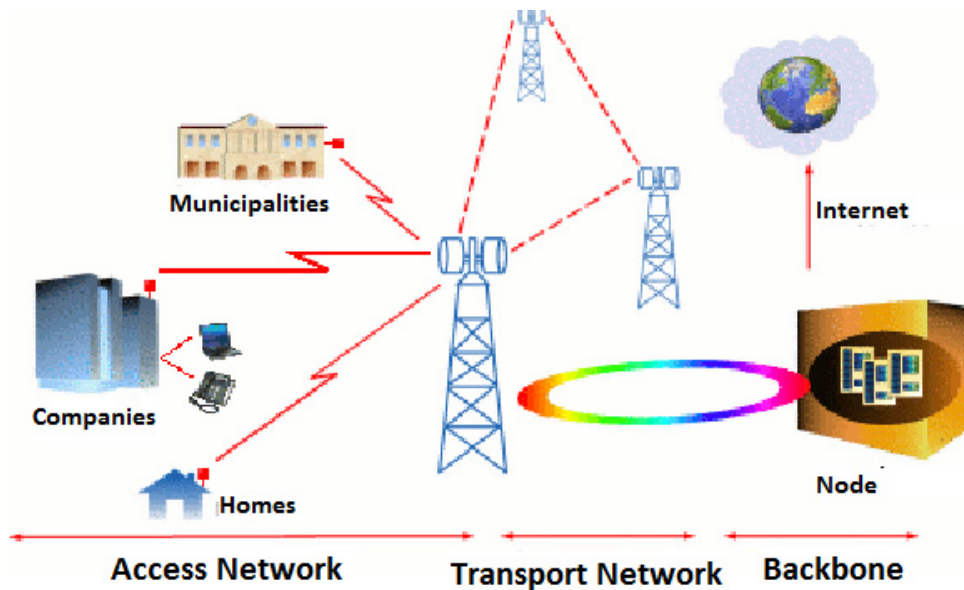


Figure 20 – Communication layer

### 2.1.2.1 Transport networks

The convergence of infrastructure already introduced earlier should be considered carefully for this type of transport of data networks in urban environments.

To transport the large amount of data that handled the smart sustainable cities will be necessary for local governments to implement national policies for the deployment broadband networks.

#### Optical Transport

Fiber is the optimum physical medium to transmit large amounts of data over long distances. The bandwidth-over-distance capabilities of fiber by far exceed those of any other medium such as copper or wireless technologies. Fiber-optic transport is therefore the unchallenged foundation for all high-speed networks.

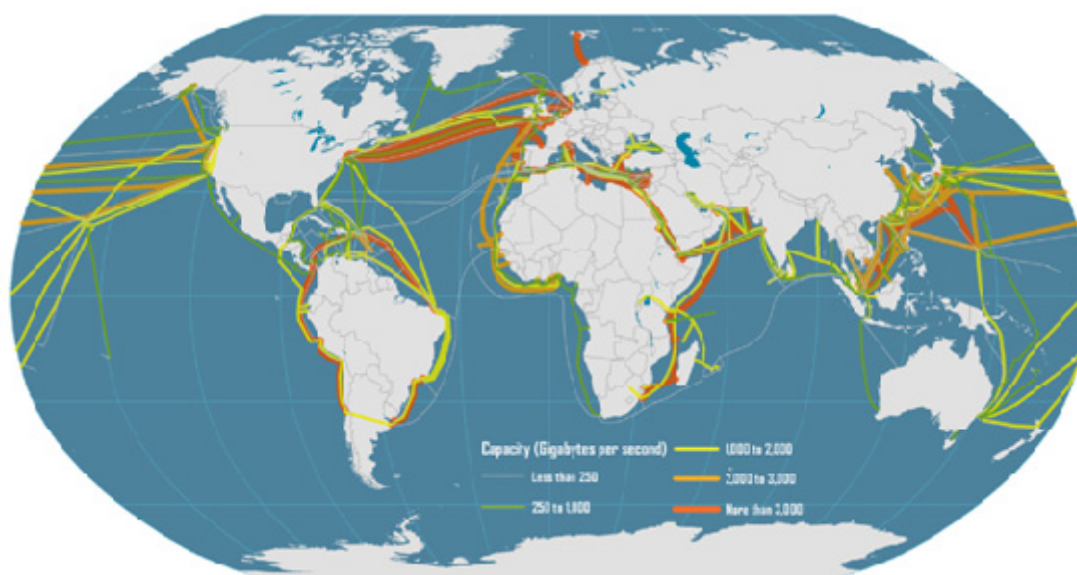


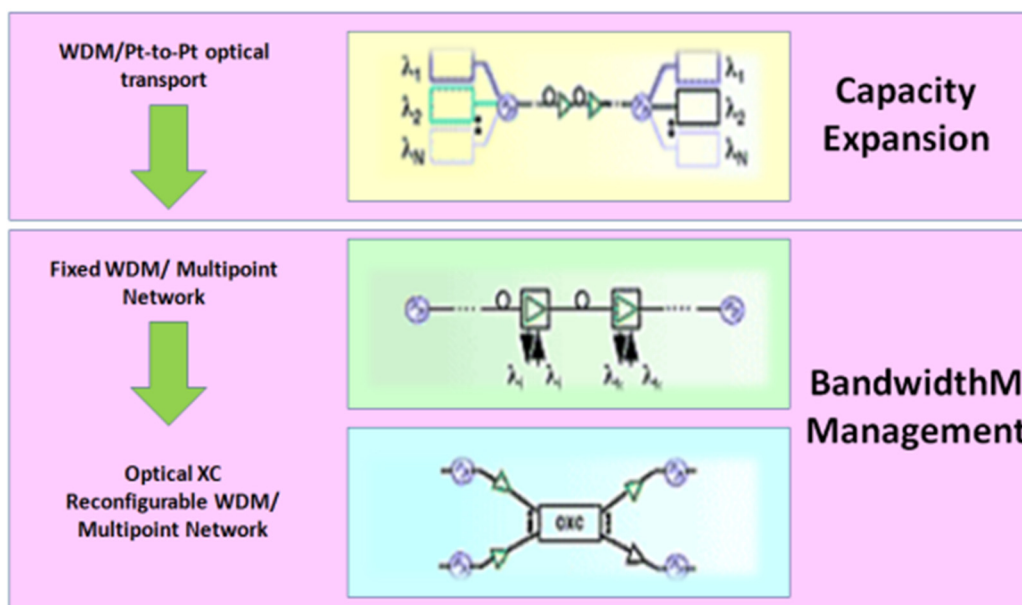
Figure 21 – Fiber optic networks worldwide

### Dense Wavelength Division Multiplexing (DWDM)

This is an optical multiplexing technology used to increase bandwidth over existing fiber networks. DWDM works by combining and transmitting multiple signals simultaneously at different wavelengths on the same fiber. The technology creates multiple virtual fibers, thus multiplying the capacity of the physical medium.

WDM has revolutionized the cost per bit of transport. Owing to DWDM, fiber networks are capable of carrying multiple Terabits of data per second over thousands of kilometers – at cost points unimaginable less than a decade ago. State-of-the-art DWDM systems support up to 192 wavelengths on a single pair of fiber, with each wavelength transporting up to 100Gbit/s capacity – 400Gbit/s and one Terabit/s on the horizon.

DWDM provides ultimate scalability and reach for fiber networks. Without the capacity and reach of DWDM systems, most Web 2.0 and cloud-computing solutions today would not be feasible. Establishing transport connections as short as tens of kilometers to enabling nationwide and transoceanic transport networks, DWDM is the workhorse of all the bit-pipes keeping the data highway alive and expanding.

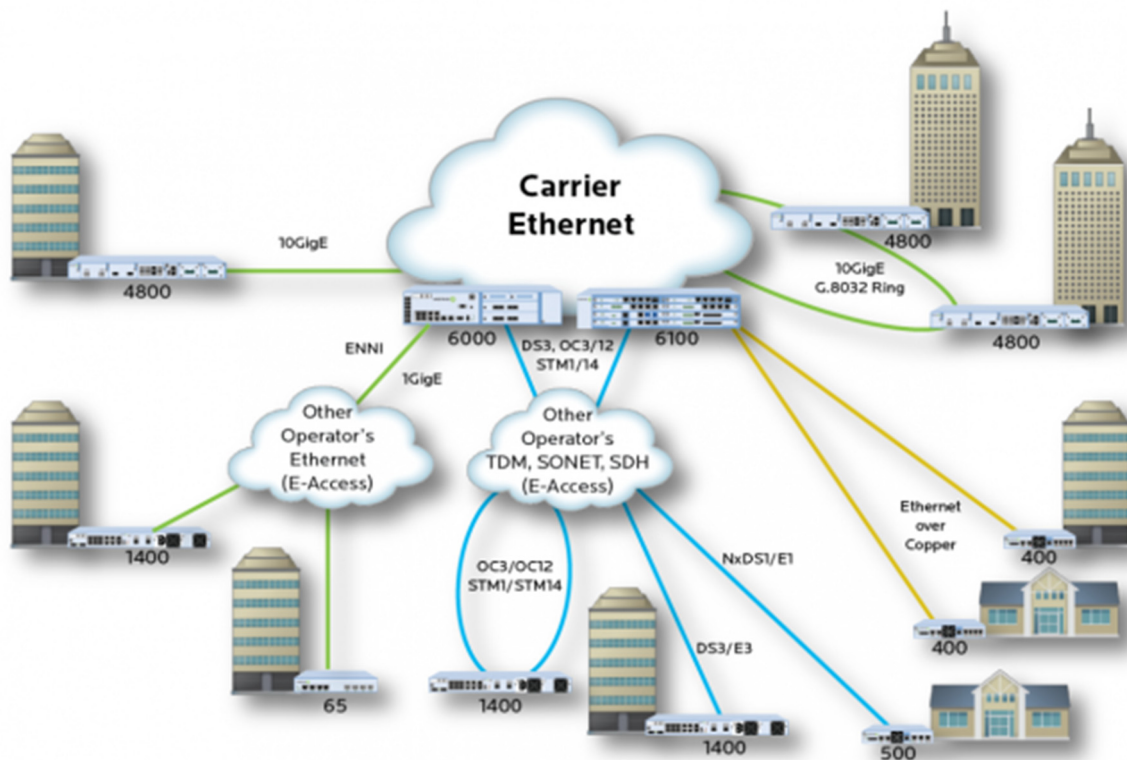


**Figure 22 – Optical transport to optical networking: evolution of the photonics layer**

Use of DWDM allows providers to offer services such as e-mail, video, and multimedia carried protocol (IP) data over asynchronous transfer mode (ATM) and voice carried over SONET/SDH. Despite the fact that these formats-IP, ATM, and SONET/SDH-provide unique bandwidth management capabilities, all there can be transported over the optical layer using DWDM. This unifying capability allows the service provider the flexibility to respond to customer demands over one network.

### Ethernet data link

In a world that is moving to a packet-based future, Ethernet is the dominant data-link protocol for today's networks, supporting a multitude of communication applications. Also, Ethernet is one of the key protocols used to interconnect routers and to carry applications in high-speed optical networks to backhaul access traffic.



**Figure 23 – Ethernet is the dominant data-link protocol**

Source Overture<sup>7</sup>

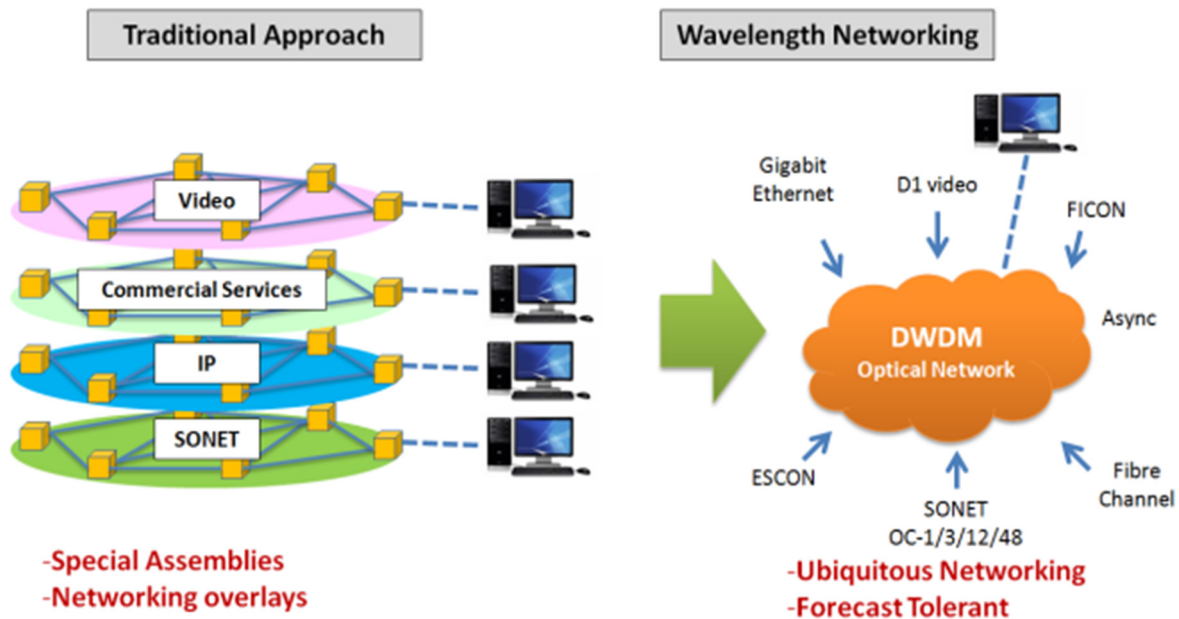
**Optical+Ethernet (Foundation for high-speed Networks)**

The combination of fiber-optic transmission technology and Ethernet-optimized data processing (Optical+Ethernet) is the perfect solution to deliver high-speed connectivity for data, storage, voice and video applications.

Optical+Ethernet innovation enables us to advance the transformation of packet-oriented optical networking and increase the efficiency of existing network infrastructures. Wavelength Division Multiplexing (WDM) technology provides more capacity, higher speeds, longer reach and a greater utilization of optical networks. As a result, networks become more manageable, operate more efficiently and transport considerably higher bandwidth for high-volume data transmission.

<sup>7</sup> link not working 404 page not found





One Network = Rapid Services Turn-up & Reduced Operations Costs

**Figure 24 – Convergence at the optical layer**

### MPLS (Multiprotocol Label Switching)

Using MPLS the traffic engineering capabilities are integrated into Layer 3 (OSI) which optimizes the routing of IP traffic through the guidelines established by the topology and the trunk capacities.

MPLS IP VPN gives a network of separate and independent communication for all its offices in the Telecommunications Network. Its benefits are:

- Access to all information wirelessly.
- Connecting stable, private and secure.
- Availability for teleconferencing, video-calls and unlimited exchange of information in real time.
- Total availability of corporate headquarters from a single point.
- Implementation of loyalty systems and databases such as CRM, SAP, ORACLE, ERP, etc.
- Transmission of data, images and voice.

MPLS could be divided into 2 category, MPLS for user access network, MPLS-TP (Transport Profile) for transport network.

#### 2.1.2.2 Access networks

These are shaped by fixed and mobile access, preferably by broadband communication networks. Mobile networks are especially important for a smart sustainable city to permit permanent and wireless connection of objects, people and environments





**Figure 25 – Sensing and Network Layer**

Source: Ministry of Transportation and Communications of Peru

### MPLS and Ethernet as Access Networks

These types of networks are used mainly as part of the transport facilities inside telecommunication networks; but also can be used as access networks specifically in business environments for the connectivity for example of branch offices.

### FTTX Access Networks

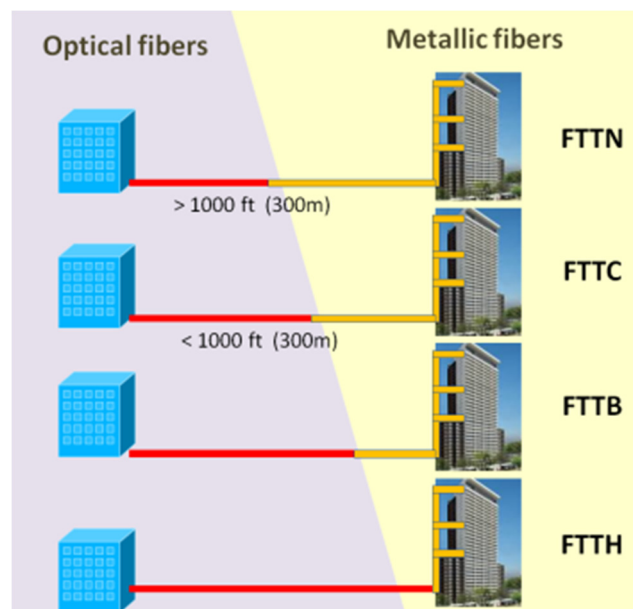
Fiber to the X (FTTX) is a generic term for any broadband network architecture using optical fiber to provide all or part of the local loop used for last mile telecommunications. The term is a generalization for several configurations of fiber deployment, ranging from FTTN (fiber to the neighborhood) to FTTH (fiber to the desktop).

One of the most used technologies for FTTX is the passive optical network (PON). It is a point-to-multipoint fiber to the premises network architecture in which unpowered optical splitters utilizing Brewster's angle principles are used to enable a single optical fiber to serve multiple premises, typically 32 to 128. A PON consists of an optical line terminal (OLT) at the service provider's central office (CO) and a number of optical network units (ONUs) near end users. A PON configuration reduces the amount of fiber and CO equipment required compared with point to point architectures.

The telecommunications industry differentiates between several distinct FTTX configurations. The terms in most widespread use today are:

1. FTTN / FTTLA (fiber-to-the-node, -neighborhood, or -last-amplifier): fiber is terminated in a street cabinet, possibly miles away from the customer premises, with the final connections being copper. FTTN is often an interim step toward full FTTH and is typically used to deliver advanced triple-play telecommunications services.

2. FTTC / FTTK (fiber-to-the-curb/kerb, -closet, or -cabinet): This is very similar to FTTN, but the street cabinet or pole is closer to the user's premises, typically within 1,000 feet (300 m), within range for high-bandwidth copper technologies such as wired Ethernet or IEEE 1901 power line networking and wireless Wi-Fi technology. FTTC is occasionally ambiguously called FTTP (fiber-to-the-pole), leading to confusion with the distinct fiber-to-the-premises system.
3. FTTP (fiber-to-the-premises): This term is used either as a blanket term for both FTTH and FTTB, or where the fiber network includes both homes and small businesses.
  - a. FTTB (fiber-to-the-building, -business, or -basement): Fiber reaches the boundary of the building, such as the basement in a multi-dwelling unit, with the final connection to the individual living space being made via alternative means, similar to the curb or pole technologies.
  - b. FTTH (fiber-to-the-home): Fiber reaches the boundary of the living space, such as a box on the outside wall of a home. Passive optical networks and point-to-point Ethernet are architectures that deliver triple-play services over FTTH networks directly from an operator's central office.
4. FTTD (fiber-to-the-desktop): Fiber connection is installed from the main computer room to a terminal or fiber media converter near the user's desk.
5. FTTE / FTTZ (fiber-to-the-telecom-enclosure or fiber-to-the-zone) is a form of structured cabling typically used in enterprise local area networks, where fiber is used to link the main computer equipment room to an enclosure close to the desk or workstation. FTTE and FTTZ are not considered part of the FTTX group of technologies, despite the similarity in name.



**Figure 26 – FTTX Access Networks**

Increased competition from multiple system operators (MSOs), telecommunications, and Internet Protocol television (IPTV) service providers worldwide are driving the deployment of quadruple-play services over next-generation access networks. As a result, service providers are faced with many new business and service delivery challenges. New optical access networks delivering higher bandwidths for increased service offerings.

Whether the access network is purely optical fiber-to-the home (FTTH) or based on a mixed fiber/copper technology (fiber-to-the curb [FTTC], fiber-to-the business [FTTB]), the requirements for operation and maintenance are changing dramatically compared to pure digital subscriber loop (DSL)-based access. At the same time, expectations have been set to reduce the maintenance effort especially on the fiber network, because it is regarded as more reliable than copper.

### XDSL (X Digital Subscriber Line)

This is a family of technologies that allows access to provide broadband access network over conventional telephony (PSTN). Therefore, in the copper, the data are transmitted in a frequency range higher than that used for voice, while avoiding the mutual interference. Implementation of DSL modem requires placing a client (Modem) at home and an equipment (called Digital Subscriber Line Access Multiplexer DSLAM) in the central operator. One of the main considerations in the deployment of this technology is the length of the local loop, as given band width is inversely proportional to this length.

The example in the following Figure shows how the different access networks connect homes.

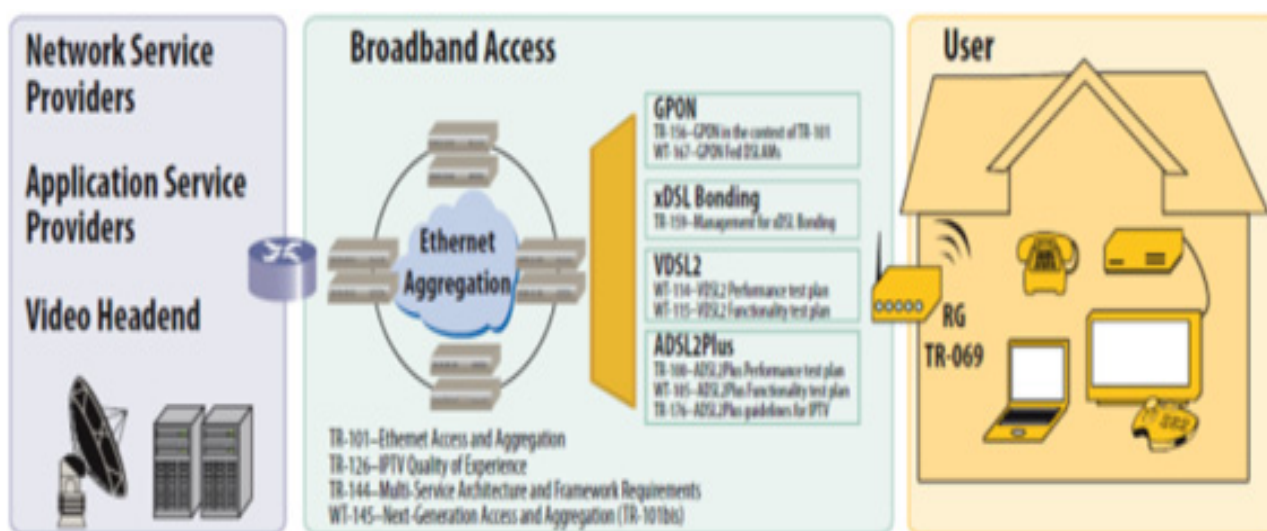


Figure 27 – Broadband Access

### Mobile Broadband Wireless Access Technologies

Wireless broadband technologies provide ubiquitous broadband access to mobile users and to all kind of terminal equipment, enabling consumers with a broad range of mobility and a variety of wireless multimedia services and applications. Broadband wireless access technologies provide broadband data access through wireless media to consumer and business markets.

There have been continued efforts to deliver ubiquitous broadband wireless access by developing and deploying advanced radio access technologies such as 3GPP UMTS and LTE, as well as mobile WiMAX systems; commercially known as 3G and 4G technologies. In the future, it is expected that 5G will deliver higher speeds.

The broadband wireless access is also an attractive option to network operators in geographically remote areas with no or limited wired network. The advantages in terms of savings in speed of deployment and installation costs are further motivation for broadband wireless access technologies.

There are various types of broadband wireless access technologies that are classified based on the coverage area and user mobility as follows:

1. Personal Area Network (PAN) is a wireless data network used for communication among data devices/peripherals around a user. The wireless PAN coverage area is typically limited to a few meters with no mobility. Examples of PAN technologies include Bluetooth or IEEE 802.15.1 and Ultra-Wideband (UWB) technology.
2. Local Area Network (LAN) is a wireless or wireline data network used for communication among data/voice devices covering small areas such as home or office environments with no or limited mobility. Examples include Ethernet (fixed wired LAN) and Wi-Fi or IEEE 802.11 (wireless LAN for fixed and nomadic users).
3. Metropolitan Area Network (MAN) is a data network that connects a number of LANs or a group of stationary/mobile users distributed in a relatively large geographical area. Wireless infrastructure or optical fiber connections are typically used to link the dispersed LANs.  
Examples include the IEEE 802.16-2004 (fixed WiMAX) and Ethernet-based MAN.
4. Wide Area Network (WAN) is a data network that connects geographically dispersed users via a set of inter-connected switching nodes, hosts, LANs, etc., and covers a wide geographical area.  
Examples of WAN include the Internet and national cellular networks.

The user demand for broadband wireless services and applications are continually growing. Also the connection of the elements for SSC will increase this demand. Offering customized and ubiquitous services based on diverse individual and SSC needs through versatile communication systems will require certain considerations in the technology design and deployment.

### The 4th Generation of Mobile Broadband Wireless Access Technologies

International Mobile Telecommunications-Advanced (IMT-Advanced) or alternatively 4th Generation (4G) cellular systems are mobile systems that extend and improve upon the capabilities of the IMT-2000 family of standards. Such systems are expected to provide users with access to a variety of advanced IP-based services and applications, supported by mobile and fixed broadband networks, which are predominantly packet-based. The IMT-Advanced systems can support a wide range of data rates, with different quality of service requirements, proportional to user mobility conditions in multi-user environments.

### Millimeter Wave Communication<sup>8</sup>

**High capacity wireless communication technology using impulse radio operating in the millimeter wave E-band:**

Expanding use of applications of sensor networks and/or Internet of things (IoT) for SSC requires a huge amount of data to be transferred on the telecommunication networks of the cities.

Moreover, due to the popularity of smartphones and tablets in recent years, along with the growing volumes of content handled by such devices, there has been a sharp increase in traffic passing through mobile networks and other communications channels.

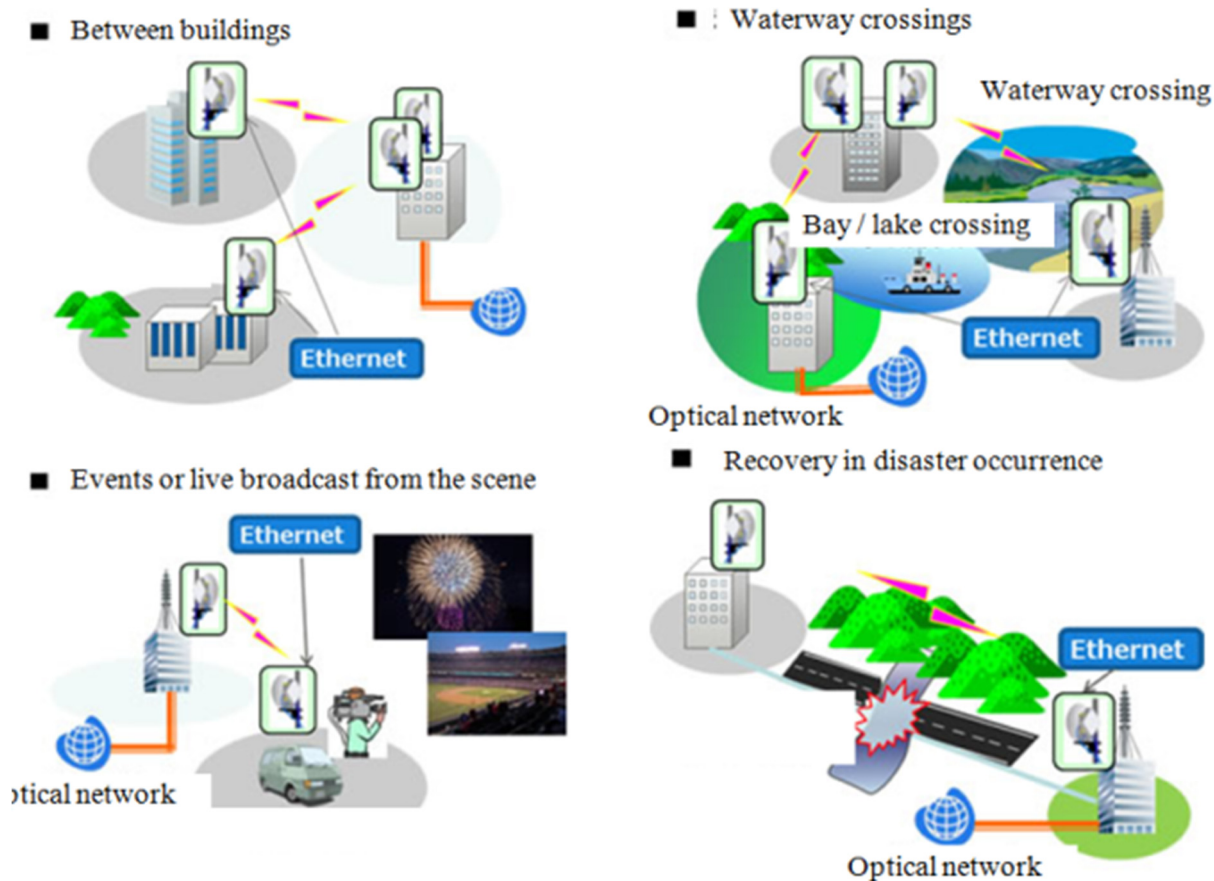
---

<sup>8</sup> Corresponds to a contribution of FUJITSU (Japan) by document FG-SSC-0061

Mainly, optical cables are used for backbone broadband network. However, wireless broadband technology complement to the optical cables is also required to meet the telecommunication demand for more flexibility.

In some cases, it is difficult to lay cables. Such cases include providing services around waterway crossings and between buildings. In other cases, it is not efficient to lay cables. Such cases include providing services for use at temporary events and for rapid network recovery in emergency occasions like big natural disasters.

The following figures show use cases of the technology:



Setting transmission equipment at each of two sites (Figure below), the distance between them is several kilometers; data is to be transmitted between them wirelessly. Operating in the millimeter wave allows the system to access to a wider radio frequency spectrum and prevents the radio wave from interfering with other radio waves as a result of the rectilinear propagation characteristic. Transmission rate of few Gbps comparable to optic cables is achieved.





**Figure 28 – Example installation**

From an environmental point of view, to consume less electricity:

- It is required to consume less electricity per unit amount of transmission of data in order to reduce the environmental burden.
- It is also required to use less electricity when some data is transmitted along the same distance.
- It is preferable to be able to obtain electricity autonomously using natural energy such as wind power and energy from sunlight.

To be small and lightweight:

- It is required to be easily installed and used for temporary radio relays or live broadcast from the events sites as well as the means of rapid network recovery in emergency where mobility characteristic is required.
- It is preferable to be able to lessen the number of component parts or the amount of volume to contain in order to reduce the environmental burden. For example, impulse radio wireless technology allows the system not to use oscillators which are likely to be large-size.

### Connectivity to Internet

Internet connections through the many access networks listed before, are a solution for SSC data transmission. As security is an extremely important element, Virtual Private Networks (VPN) are necessary to send data over the Internet. Encryption in these VPN is vital for the safe transport of data. A VPN is a private network in logical terms, mounted potentially on a shared medium.

The Internet solution is a very economical option compared to using private channels from MPLS or Ethernet networks, but depends on the speed and availability of broadband Internet access. The Virtual Private Network (VPN) perfectly fits the requirements: security, data encryption, transparency and lower monthly costs.

Tasks that must satisfy a VPN are:

- Remote access to databases, servers, etc.
- Authentication of both ends of the connection (main office and remote office).
- Ability to send IP packets through a tunnel in the public network (Internet), so that the two segments of the network interconnecting remote LAN does not appear to be geographically separated.



- Encryption of data traveling over a public network (Internet) so that nobody can decipher its contents.
- National coverage.
- Massive transfer of information.

## 2.2 ICT facilities: over the top, services, applications and contents

This section addresses the application and security layers illustrated in Figures 4 and 5, and contains specifications for corresponding ICT facilities.

### 2.2.1 ICT integrated services capacity

The capacity of integration of services has a direct relationship with interoperability, which is decisive. Every entity involved in the development SSC applications shall adopt open standards that enable interoperability between information systems with the systems of other actors, public and private, and for data captured through smart devices of citizens serve as basis for open and reuse data and generate new services and platforms.

### 2.2.2 Data management

#### 2.2.2.1 Data security

As stated in the European Commission Project SMARTIE (Secure and Smarter Cities Data Management)<sup>9</sup>: "A secure, trusted, but easy to use (...) system for a smart city will benefit the various stakeholders of a smart city. This also holds true for SSC. The city administration will find it easier to get information from their citizens while protecting their privacy. Furthermore, the services offered will be more reliable if quality and trust of the underlying information is ensured".

There are numerous risks to be addressed involving all levels of data of the system itself, and considering citizens' concerns about data intrusion, then security becomes a key concept in the adoption and sustainability of a smart city, some of these risk are<sup>10</sup>:

- Event-driven agents to enable an intelligent/self-aware behavior of networked devices.
- Authentication and data integrity.
- Models for decentralized authentication and trust.
- Security and trust for cloud computing.
- Data ownership, repository data management, privacy policies management and privacy preserving technologies.
- Legal and liability issues (etc.).

#### 2.2.2.2 Integration of heterogeneous data

The sensing of urban spaces and the participation of society in the generation of content and social networks exponentially increases the volume of information available. There are three "V" of interest in large data volumes (i) the Volume or the amount of processed information, (ii) the Variety of the types of data that can be represented, and (iii) the Velocity (speed) at which are captured, transferred and processed these data.

<sup>9</sup> Security and Privacy Challenge in Data Aggregation for the IoT in Smart Cities (from [http://www.smartie-project.eu/publication\\_bohli2013a.html](http://www.smartie-project.eu/publication_bohli2013a.html))

<sup>10</sup> Taken from "Internet of Things Strategic Research Roadmap" Page 34

**Technology to create, integrate and search the heterogeneous and multi-domain data, and deliver the unified information<sup>11</sup>:**

A large-scale electronic data is generated constantly by the progress of ICT utilization and application in various sectors such as environment, medical care, administration, and education.

It reduces environmental impact, and promotes the sustainable development of the city to utilizing these heterogeneous and multi-domain data effectively in an integrated manner.

Therefore, it is proposed to include a specific type of technology to create, integrate, and search the heterogeneous and multi-domain data, and deliver the unified information as a fundamental technology for ICT infrastructure of smart sustainable cities.

**Role of the technology**

In smart sustainable cities, the environmental monitoring with a huge number of sensing devices generates a large-scale electronic data. A large scale electronic data is also generated constantly by the progress of ICT utilization and application in various sectors such as medical care, administration and education sector.

Large amounts of generated data is integrated in various forms in each domain, and utilized in cloud environment with huge data centers and high-speed networks. It can realize sustainable improvement of environment, energy, economy, and society to utilize these heterogeneous and multi-domain data efficiently.

Thus, the technology is required to create, integrate, and search efficiently and transversely the heterogeneous and multi-domain data, and deliver the unified information. The technology can realize not only the environment impact reduction but also the community revitalization, the reinforcement of disaster prevention, and the improvement of citizens' life.

This technology enables to provide the highly correlated data set group from enormous data, and is applicable to the environment impact reduction, the energy management, the remote medical care, the disaster monitoring, e-Government, and so on.

There are applications of this technology that can support disaster prevention and monitoring; ICT utilization in Smart Sustainable city is one of the solutions for this key role in future cities.

During disasters it is very difficult to recognize the extent of overall damage. Dealing with disaster many troubles occur without information sharing among various organizations and individuals.

The technology can solve these issues by providing the appropriate information from various information accumulated including science, administrative, and SNS information.

**Requirements of the technology**

To be able to recognize the damage situation, and make a decision appropriately with the technology to create, integrate, and search the heterogeneous and multi-domain data and deliver the unified information.

Highly correlated data set group can be discovered by searching and integrating transversely the huge heterogeneous and multi-domain data with the combination of spatio-temporal correlation, ontological correlation, and citational correlation analysis. These huge data include real sensing data, social sensing data from SNS, Web archive, and scientific database, which are collected and accumulated via the Internet from various individuals and organizations such as victims, rescuers, and media.

---

<sup>11</sup> Corresponds to a contribution of FUJITSU (Japan) by document FG-SSC-0036

For example, when one analyses the potential effects of environmental damage such as particular matter air pollution (PM2.5), it is a crucial to find correlated datasets from a wide variety of sensor data individually disseminated from heterogeneous sensing sources through the Internet and sensor networks. Related to the PM2.5 sensor data, the highly correlated environmental sensor data (wind speed and direction, rainfall, temperature, humidity) and social sensor data (SNS data with the keyword about a climate and the health) can be found with the spatio-temporal correlation (nearoverlapping in time and location, same movement and so on) and ontological correlation (atmospheric pollution, weather, respiratory disease, and so on). These data set and their correlations are forwarded for further analysis to create and verify the correlative hypothesis with up-to-date and/or unknown PM2.5 effects.

**Other possible effect(s) of the technology (to be applicable to climate change adaptation and mitigation):**

To sort and analyze the information of some event in depth, it is generally important to collect the information not only in the particular field concerned but also in the various derived and affected fields.

For example, in order to sort and analyze the issue on "global warming", without the technology, it is necessary to search various information one by one to recognize the relationship among various fields, but using this technology it is easy to obtain horizontal search results including various industry, economy, energy problem, hygiene and education as well as natural disaster using climate change as search key. The technology can support the data-intensive science and give a very good sketch of various events of the real world based on many heterogeneous and multi-domain information.

### 2.2.3 Cloud computing and data platform

Cloud computing is another technology that is being used to build SSC, in line with the policies of green technologies to be adopted. In all cases the public administration shall ensure protection the privacy of people. Cloud computing is also one of the main forms of Green IT that refers to the efficient use of computing resources thus minimizing the environmental impacts and contribute to the reduction in energy consumption or greenhouse gas emissions.

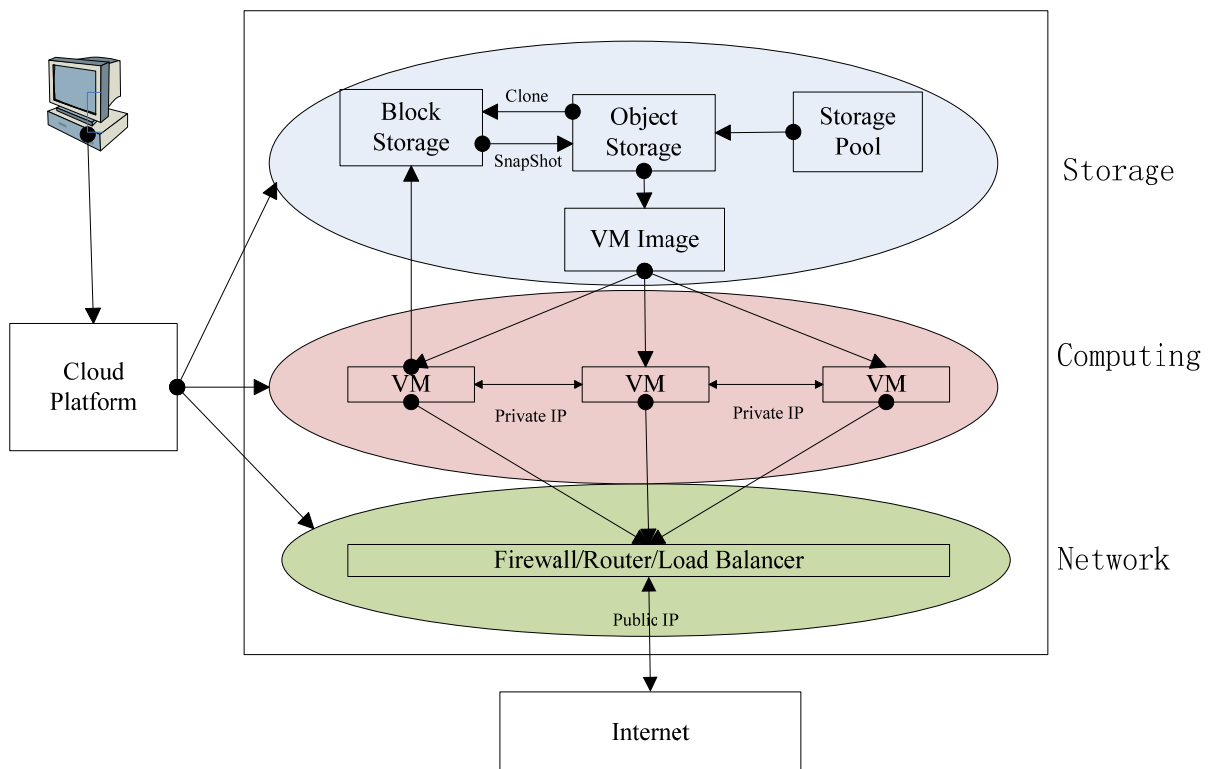
The need of "the cloud approach, in which providers outside city government deliver a technological platform for gathering and mining data and producing city applications over the public Internet or a virtual private network, has become the favored means for municipalities to move to the next level"<sup>12</sup>, and that is because it's cost effective and time and effortless solution, because most cities infrastructure aren't equipped to work with any levels of infrastructure in a smart sustainable city, on the other hand, cloud service suppliers are capable to sort, in a good manner, many of the risks involved.

The convergence of cloud technologies should be well utilized. These include SaaS (Software as a Service), STaaS (Storage as a Service), IaaS (Infrastructure as a Service) and more, to increase availability, reliability, increase security and deliver optimum quality of service applications for the large number of heterogeneous devices and platforms.

An example of IaaS Cloud Computing architecture is as follows<sup>13</sup>:

<sup>12</sup> Why Smart Cities Need Cloud Services  
([http://www.ubmfuturecities.com/author.asp?section\\_id=234&doc\\_id=526607](http://www.ubmfuturecities.com/author.asp?section_id=234&doc_id=526607))

<sup>13</sup> Examples extracted from recent progress of ITU-T SG13.



**Figure 29 – Example of IaaS Cloud Computing architecture**

The facility of storage, computing and network can be virtualized, and managed in a unified manner. So the allocation and scheduling of resource will allow for more agility, and the efficiency of resource is also higher than traditional architecture.

The secondary use of various data (so-called big data), such as individuals, companies, and organizations is very useful for SSC as described<sup>14</sup>:

#### **Example 1: HEMS/BEMS data**

The electricity demand prediction using the real-time data from smart meters enables the balancing of electricity supply-demand.

#### **Example 2: Movement history data**

The collection and analysis of individual movement histories enables to offer congestion expectation information and detour information at the time of an accident outbreak.

#### **Example 3: Medical examination history data**

The collection and analysis of medical examination histories enables to identify the infection route and to take countermeasures of the infection expansion.

On the other hand, as for just distributing the data, there is a problem of the invasion of privacy and the leakage of confidential information.

Therefore, the protocol for the secondary use of data with anonymity techniques is necessary. Moreover, even if an authorized anonymity technique is repeatedly used to anonymize private data for its publication, it may cause the leak of private data when the anonymization process was

<sup>14</sup> Please refer to the technical report of Anonymization Infrastructure and Open Data for Smart Sustainable Cities.

accomplished independently. To prevent the leak and certify the published privacy data, anonymization infrastructure is indispensable for the future SSC applications including big-data business.

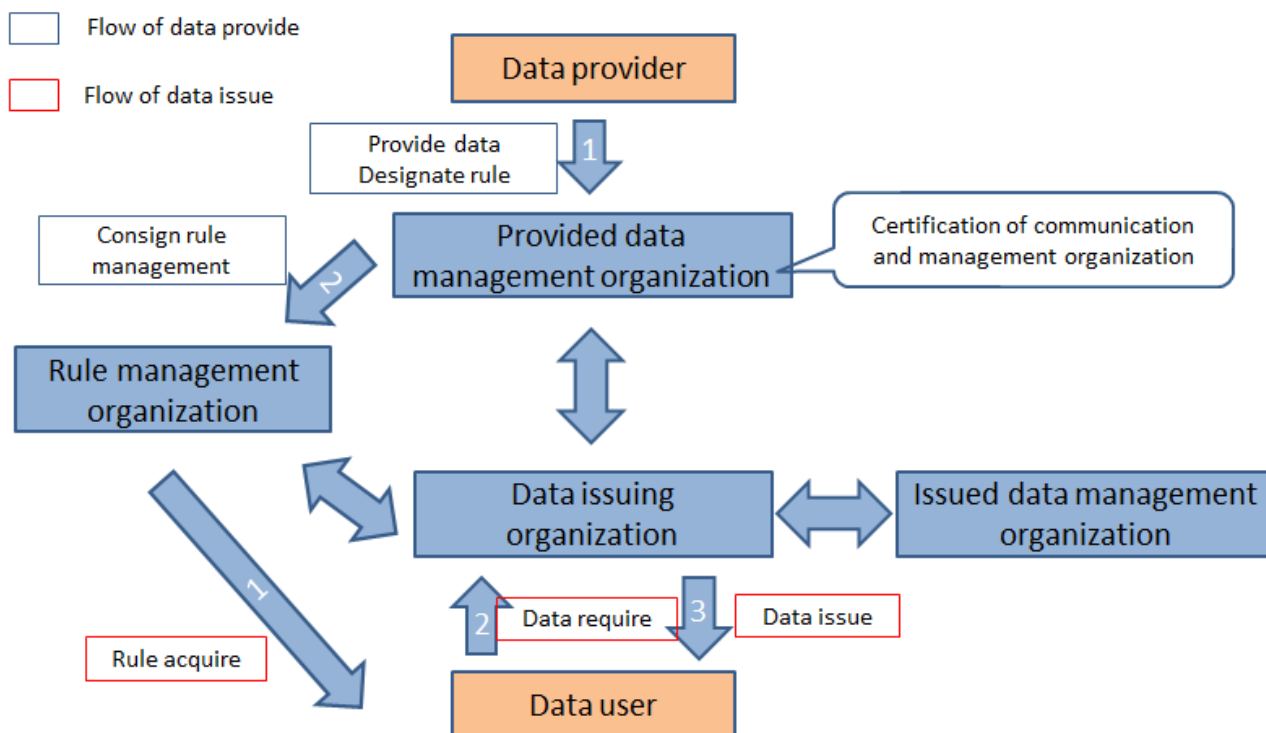


Figure 30 – Proposed protocol for the secondary use of various data

### 2.2.4 Augmented reality

The potential of the use of augmented reality is infinite and they are still discovering many of their applications, for example, new augmented reality technology takes designs of proposed building developments and transposed them onto a smartphone or similar device. Using this, the inhabitants of a smart sustainable city can visualize how the final result would be to make informed planning decisions. Police services can use viewers of augmented reality with facial recognition for identification of criminals, and tourists can be guided and can also display information of the attractions or monuments of the city, etc.

## 2.3 Terminals, Sensing and multi-device layer

This section contains specifications for the users layer (Figure 5) and sensing layers (Figures 4 and 5).

### 2.3.1 Terminals (Gateways)

The network is not complete without interconnection equipment on the one hand and on the other with their ends that reach users and things. Sensors are one of the most important types of terminals, which are discussed in the next section.

### 2.3.2 Sensor

They consist of sensors of resources, security, lighting, presence, weather, transportation, movement or position installed on the physical infrastructure of the SSC. These devices make it possible to meet and study the phenomena of public and private interest such as climate, congestion

of the roads, the air pollution, the behavior of criminals or those attending sporting, cultural events and entertainment.

### 2.3.2.1 System Architecture for Wireless Sensor Networks

The emerging field of wireless sensor networks combines sensing, computation, and communication into a single tiny device. Through advanced mesh networking protocols, these devices form a sea of connectivity that extends the reach of cyberspace out into the physical world. As water flows to fill every room of a submerged ship, the mesh networking connectivity will seek out and exploit any possible communication path by hopping data from node to node in search of its destination. While the capabilities of any single device are minimal, the composition of hundreds of devices offers radical new technological possibilities.

The power of wireless sensor networks lies in the ability to deploy large numbers of tiny nodes that assemble and configure themselves. Usage scenarios for these devices range from real-time tracking or monitoring of environmental conditions, to ubiquitous computing environments, in situ monitoring of the health of structures or equipment, among others. While often referred to as wireless sensor networks, they can also control actuators that extend control from cyberspace into the physical world.

The concept of wireless sensor networks is based on a simple equation:

$$\text{Sensing} + \text{CPU} + \text{Radio} = \text{Thousands of potential applications}$$

However, actually combining sensors, radios, and CPU's into an effective wireless sensor network requires a detailed understanding of both capabilities and limitations of each of the underlying hardware components, as well as a detailed understanding of modern networking technologies and distributed systems theory. Each individual node must be designed to provide the set of primitives necessary to synthesize the interconnected web that will emerge as they are deployed, while meeting strict requirements of size, cost and power consumption. A core challenge is to map the overall system requirements down to individual device capabilities, requirements and actions. To make the wireless sensor network vision a reality, an architecture that synthesizes the envisioned applications out of the underlying hardware capabilities must be developed.

### 2.3.2.2 Sensor network application classes

The three application classes, which have been selected are: environmental data collection, security monitoring, and sensor node tracking. It is believed that the majority of wireless sensor network deployments will fall into one of these class templates.

#### Environmental Data Collection

An environmental data collection application is to collect several sensor readings from a set of points in an environment over a period of time in order to detect trends and interdependencies. The idea is to collect data from hundreds of points spread throughout the area and then to analyze the data offline.

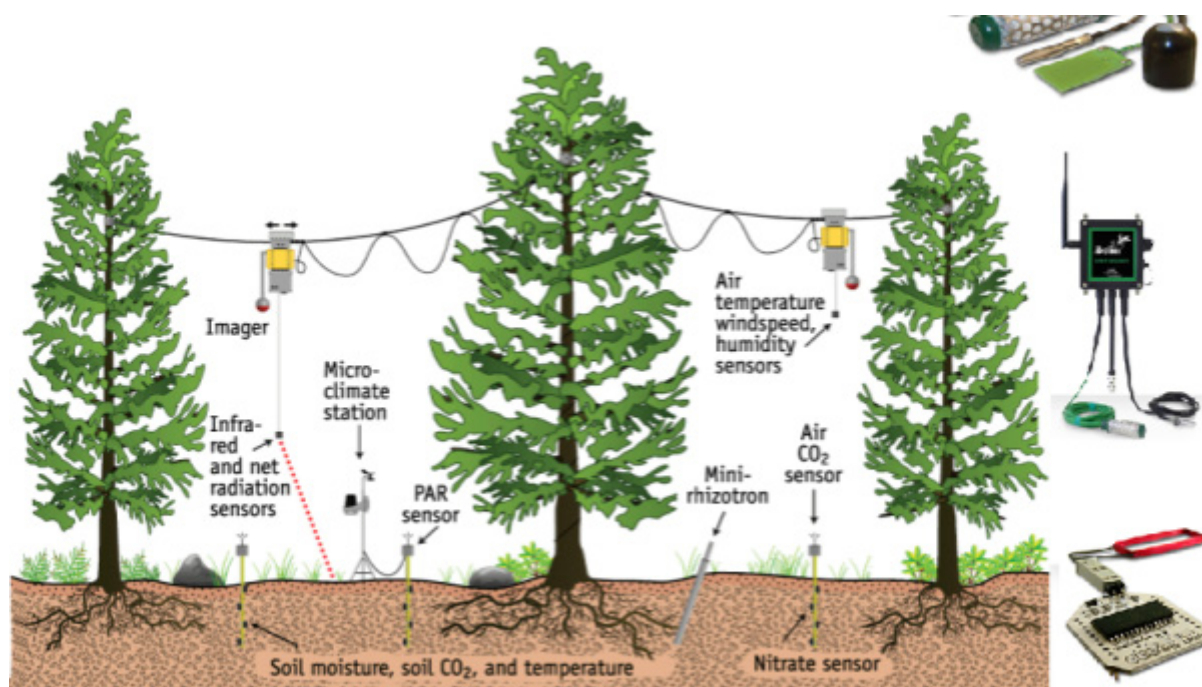
At the network level, the environmental data collection application is characterized by having a large number of nodes continually sensing and transmitting data back to a set of base stations that store the data using traditional methods. These networks generally require very low data rates and extremely long lifetimes. In typical usage scenario, the nodes will be evenly distributed over an outdoor environment. This distance between adjacent nodes will be minimal yet the distance across the entire network will be significant.



Environmental data collection applications typically use tree-based routing topologies where each routing tree is rooted at high-capability nodes that sink data. Data is periodically transmitted from child node to parent node up the tree-structure until it reaches the sink. With tree-based data collection each node is responsible for forwarding the data of all its descendants. Nodes with a large number of descendants transmit significantly more data than leaf nodes. These nodes can quickly become energy bottlenecks. Once the network is configured, each node periodically samples its sensors and transmits its data up the routing tree and back to the base station. For many scenarios, the interval between these transmissions can be on the order of minutes. Typical reporting periods are expected to be between 1 and 15 minutes; while it is possible for networks to have significantly higher reporting rates. The typical environment parameters being monitored, such as temperature, light intensity, and humidity, do not change quickly enough to require higher reporting rates.

In addition to large sample intervals, environmental monitoring applications do not have strict latency requirements. Data samples can be delayed inside the network for moderate periods of time without significantly affecting application performance. In general the data is collected for future analysis, not for real-time operation.

The most important characteristics of the environmental monitoring requirements are long lifetime, precise synchronization, low data rates and relatively static topologies. Additionally it is not essential that the data be transmitted in real-time back to the central collection point. The data transmissions can be delayed inside the network as necessary in order to improve network efficiency.



**Figure 31 – Environmental Data Collection**

## Security Monitoring

Security monitoring networks are composed of nodes that are placed at fixed locations throughout an environment that continually monitor one or more sensors to detect an abnormality. A key difference between security monitoring and environmental monitoring is that security networks are not actually collecting any data. This has a significant impact on the optimal network architecture. Each node has to frequently check the status of its sensors but it only has to transmit a data report when there is a security violation. The immediate and reliable communication of alarm messages is the primary system requirement. Additionally, it is essential to confirm that each node is still present and functioning. If a node was to be disabled or fail, it would represent a security violation that should be reported. For security monitoring applications, the network must be configured so that nodes are responsible for confirming the status of each other. One approach is to have each node be assigned to peer that will report if a node is not functioning. The optimal topology of a security monitoring network will look quite different from that of a data collection network.

It is reasonable to assume that each sensor should be checked approximately once per hour. Combined with the ability to evenly distribute the load of checking nodes, the energy cost of performing this check would become minimal. A majority of the energy consumption in a security network is spent on meeting the strict latency requirements associated with the signaling of the alarm when a security violation occurs.

Once detected, a security violation must be communicated to the base station immediately. The latency of the data communication across the network to the base station has a critical impact on the application performance. Users demand that alarm situations be reported within seconds of detection. This means that network nodes must be able to respond quickly to requests from their neighbours in order to forward data.

Currently there is a new generation of autonomous 3G sensors equipped with video cameras that enable the development of new security, surveillance and military applications, the wireless sensor network platform for the Internet of Things.

These new video camera sensors, in conjunction with the 3G communication module, allow the creation of sensor nodes that transmit both discrete data gathered by analog and digital sensors and complex streams of real time information, such as photos and video, to servers in the Cloud.



**Figure 32 – 3G sensors stream photo and video to the Cloud for new security applications**

This type of sensors uses ZigBee, Bluetooth and Wi-Fi protocols to send low bandwidth data such as temperature, humidity and CO2 levels, and high speed W-CDMA and HSPA mobile networks to upload video.

For security applications that require night vision mode, the new video camera sensor nodes include dozens of high-power infrared (IR) LEDs, making it possible to take pictures in total darkness. The 3G module is equipped with an internal GPS that adds geolocation information to all multimedia files.

### **Node tracking scenarios**

This indicates tracking of a tagged object through a region of space monitored by a sensor network. There are many situations where one would like to track the location of valuable assets or personnel. Current inventory control systems attempt to track objects by recording the last checkpoint that an object passed through. With wireless sensor networks, objects can be tracked by simply tagging them with a small sensor node. The sensor node will be tracked as it moves through a field of sensor nodes that are deployed in the environment at known locations. Instead of sensing environmental data, these nodes will be deployed to sense the radio messages of the nodes attached to various objects. The nodes can be used as active tags that announce the presence of a device. A database can be used to record the location of tracked objects relative to the set of nodes at known locations. With this system, it becomes possible to request for the exact location of the object and not just the last location where it was last scanned.

There are two main ways of performing outdoor location tracking when sensor devices are located in a large area such as a city. The most extensive one is to use a GPS module to get the information sent by the satellites and extract all the information possible (latitude, longitude, speed, direction). However, this methodology is not effective when requiring mobile scenarios where the nodes can change from an outdoor environment to an indoor one, such as going inside buildings, garages and tunnels.

For these cases an alternative method is used which consists of taking the information sent by the Mobile Phones Cells and looking for their location in a previously saved Data Base. This information can include Cell ID, RSSI and Timing Advance (TA) of any of the Base Stations which are located in the surroundings.

Both GPS and GPRS technologies are complementary to each other as a system with both technologies allow the tracking of position inside buildings, garages, and even inside tunnels (e.g. subway railway system) while maintaining accurate precision of where the information from the GPS satellites can reach the sensor device. There are many technologies to obtain location information; some of them have been reviewed in chapter 3 (geo-localization for public safety and emergencies).



Figure 33 – Example of localization

**Hybrid networks**

Complete application scenarios generally contain aspects of all three categories. For example, in a sensor network designed to track vehicles, the network may switch between being an alarm monitoring network and a data collection network. During a long period of inactivity when no vehicles are present, the network will simply perform an alarm monitoring function. Each node will monitor its sensors while waiting to detect a vehicle. Once an alarm event is detected, all or part of the network, will switch into a data collection network mode and periodically report sensor readings to a base station, where tracking of the vehicles would be in progress. As a result of this multi-modal network behavior, it is important to develop a single architecture that can handle all the three aforementioned application scenarios.



Figure 34 – Tracking Vehicles



### 2.3.2.3 Radio network infrastructure

The radio subsystem is the most important system on a wireless sensor node, since it is the primary energy consumer among the three highlighted application scenarios. Modern low power, short range transceivers consume between 15 and 300 milliwatts of power when sending and receiving. A key hardware observation is that low power radios consume approximately the same amount of energy when in receive or transmit mode. This energy is consumed if the radio is on, whether or not it is receiving actual data. The actual power emitted out of the antenna only accounts for a small fraction of the transceiver's energy consumption. A significant fraction goes to internal operation. As a result, the overall cost of radio communication can be dominated in some cases by the receiver power consumption – a metric that is often ignored in wireless studies.

#### Transmission Range

The transmission range of a wireless system is controlled by several key factors. The most intuitive factor is that of transmission power. The more energy put into a signal, the farther it should travel. The relationship between power output and distance travelled is a polynomial with an exponent of between 3 and 4 (non-line of sight propagation). So to transmit twice as far through an indoor environment, 8 to 16 times as much energy must be emitted.

Other factors in determining range include the sensitivity of the receiver, the gain and efficiency of the antenna and the channel encoding mechanism. In general, wireless sensor network nodes cannot exploit high gain, directional antennas because they require special alignment and prevent ad-hoc network topologies. Omni-directional antennas are preferred in ad-hoc networks because they allow nodes to effectively communicate in all directions.

Both transmission strength and receiver sensitivity are measured in dBm. Typical receiver sensitivities are between –85 and –110 dBm. Transmission range increases can be achieved by either increasing sensitivity or by increasing transmission power. When transmitting at 0 dBm, a receiver sensitivity of –85 dBm will result in an outdoor free space range of 25-50 meters, while a sensitivity of –110 dBm will result in a range of 100 to 200 meters. The use of a radio with a sensitivity of –100 dBm instead of a radio with –85 dBm will allow you to decrease the transmission power by a factor of 30 and achieve the same range<sup>15</sup>.

#### Bit Rate

Unlike many high performance data networks, wireless sensor networks do not require high bit rates. 10-100 Kbps of raw network bandwidth is sufficient for many applications. Radio bandwidth has a more significant impact on node power consumption and its lifetime in case of a battery powered node. As bit rates increase, transmission times decrease. As the highest instantaneous energy consumer, it is essential that the radio remain off as much as possible. By increasing the bit rate without increasing the amount of data being transmitted, the radio duty cycle is decreased.

---

<sup>15</sup> The dB scale is a logarithmic scale where a 10 dB increase represents a 10x increase in power. The baseline of 0 dBm represents 1 milliwatt, so 1 watt is 30 dBm.

**Table 1 – Comparison of various hardware platforms for use in wireless sensor networks<sup>16</sup>**

Node Type	Sample "Name" & Size	Typical Application Sensors	Radio Bandwidth (Kbps)	MIPS	Typical Active Energy (mW)	Typical Sleep Energy (uW)	Typical Duty Cycle (%)
				FLASH			
				RAM			
Generic Sensing Platform	Mote 1-10cm <sup>3</sup>	General Purpose Sensing and Communications Relay	<100 kb/s	< 10	3V * 10-15mA	3V*10uA	1-2%
				< 0.5 Mb			
				< 10 Kb			
High Bandwidth Sensing	Imote 1-10cm <sup>3</sup>	Rich Sensing (Video, Acoustic, and Vibration)	~ 500 kb/s	< 50	3V*60mA	3V*100uA	5-10%
				< 10 Mb			
				< 128 Kb			
Gateway	Stargate >10cm <sup>3</sup>	High Bandwidth Sensing and Communications Aggregation. Gateway node.	> 500 kb/s – 10 Mb/s	> 100	3V*200mA	3V*10mA	> 50%

The last decade has seen an explosion in sensor technology. There are currently thousands of potential sensors ready to be attached to a wireless sensing platform. Additionally, advances in micro-electromechanic devices (MEMS) and carbon Nano-tubes technology are promising to create a wide array of new sensors. They range from simple light and temperature monitoring sensors to complex sensors able to monitor more parameters and work as "digital noses" for electronic air quality control etc.

#### 2.3.2.4 Interfaces

There are two general ways to interface with sensors that can be used in sensor networks: analog and digital. Analog sensors generally provide a raw analog voltage that corresponds to the physical phenomena that they are measuring. Generally these produce a continual waveform that must be digitized and then analyzed. While seemingly straightforward to integrate, raw analog sensors often require external calibration and linearization. It is common for the sensor to have non-linear response to stimuli. The host controller must then compensate in order to produce a reading in meaningful units. Depending on the characteristics of the sensor this can be a complex process. In many cases the translation may depend on other external factors such as temperature, pressure, or input voltage. A second difficulty in interfacing with raw analog sensors is that of scale. Each sensor will have different timing and voltage scales. The output voltage will generally contain a DC offset combined with a time-varying signal. Depending on the ratio of signal to DC component, an array of amplifiers and filters may be required to match the output of the sensor to the range and fidelity of the ADC being used to capture it.

Digital sensors have been developed to remove many of these difficulties. They internally contain a raw analog sensor, but provide a clean digital interface to it. All required compensation and linearization is performed internally. The output is a digital reading on an appropriate scale. The interface to these sensors is via one of a handful of standard chip-to-chip communication protocols.

<sup>16</sup> Extracted from <http://www.isi.edu/~johnh/PAPERS/Conner04a.pdf>



### 2.3.2.5 Wireless Platforms

In addition to the themes discussed earlier, there are a collection of other wireless networking platforms that are relevant.

#### ZigBee (IEEE 802.15.4)

ZigBee got its name from the way bees “zig and zag” while tracking between flowers and relaying information to other bees about where to find nectar resources. ZigBee is a new global standard for wireless connectivity, focusing on standardizing and enabling interoperability of products. It is a communications standard that provides a short-range cost effective networking capability; it has been developed with the emphasis on low-cost battery powered applications.

ZigBee is built on the robust radio (PHY) and medium attachment control (MAC) communication layers defined by the IEEE 802.15.4 standard. In contrast to standards like Bluetooth and Wi-Fi that address mid to high data rates for voice, PC LANs, video, etc. ZigBee meets the unique needs of sensors and control devices.

Sensors and controls don't need high bandwidth but they do need low latency and very low energy consumption for long battery lives and for large device arrays.

It is now widely recognized that standards such as Bluetooth and WLAN are not suited for low power applications, which is due to these standards' high node costs as well as complex and power demanding RF-ICs and protocols. With ZigBee, the case is different, it is the only standard that specifically addresses the needs of wireless control and monitoring applications.

Future sensor networks will be characterized by a large number of nodes/sensors which necessitate wireless solutions, very low system/node costs, they need to operate for years on inexpensive batteries; this requires low power RF-ICs and protocols, reliable and secure links between network nodes, easy deployment and no need for high data rates. Future sensor networks is a topic which is being discussed in ITU-T and other standards developing organizations that address issues surrounding M2M communications and IoT.

**Table 2 – Wireless standard comparisons**

<b>Standard</b>	<b>ZigBee 802.15.4.</b>	<b>Bluetooth 802.15.1.</b>	<b>Wi-Fi 802.11b</b>	<b>GPRS/GSM</b>
<b>Application</b>	Monitoring & Control	Cable replacement	Web, video, e-mail	WAN, voice/data
<b>System resource</b>	4 kb-32 kb	250 kb+	1 Mb+	16 Mb+
<b>Battery life (days)</b>	100-1000+	1-7	0.1-5	1-7
<b>Nodes per network</b>	256/65 k+	7	30	1000
<b>Bandwidth (kbps)</b>	20-250	720	11000+	64-128
<b>Range (m)</b>	1-75+	1-10+	1-100	1000+
<b>Key attributes</b>	reliable, low power, cost effective	cost, convenience	speed, flexibility	reach, quality

This technology includes application segments in home control: wireless home security, remote thermostats, remote lighting, drape controller, automated meter reading, personal healthcare and advanced tagging, call button for elderly and disabled, universal remote controller to TV and radio, lighting, wireless keyboard, mouse and game pads, wireless smoke, CO detectors, etc.

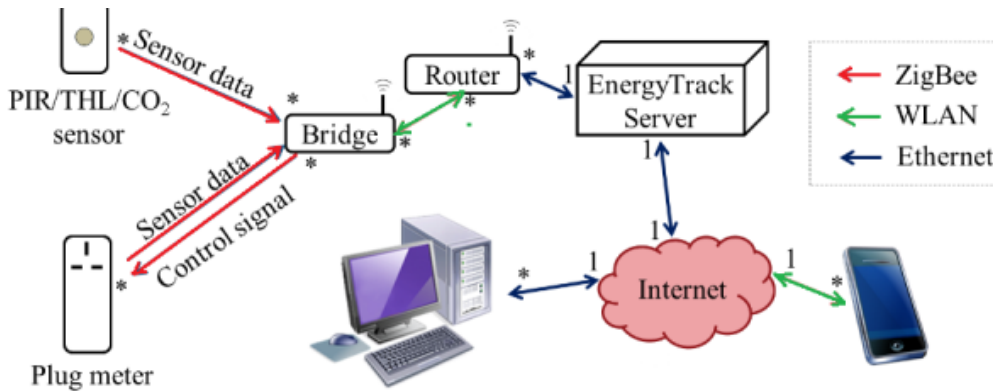


Figure 35 – ZigBee, WLAN and Ethernet

ZigBee has been widely used for its low-power consumption feature in real situations. The following figure is one of the water monitoring system by ZigBee.

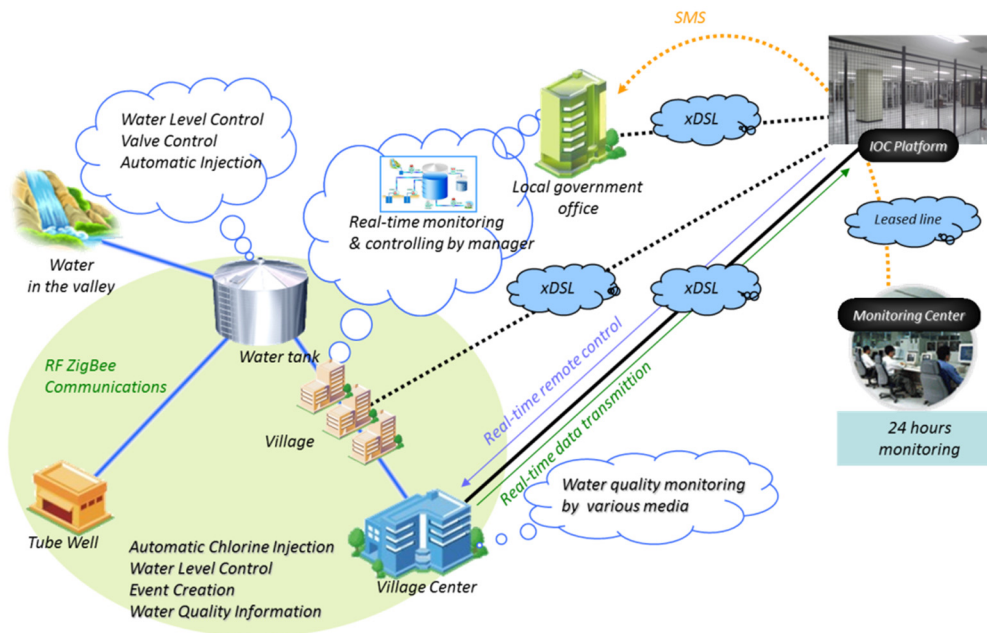


Figure 36 – Water Monitoring System by ZigBee

**RFID Radio Frequency Identification Technology**

RFID Radio Frequency Identification is a technology that is used for identification in everything from shop tagging to vehicle tracking and many more applications.

RFID technology is a simple method of exchanging data between two entities namely a reader/writer and a tag. This communication allows information about the tag or the element carrying the tag to be determined and in this way, it enables processes to be managed more easily.

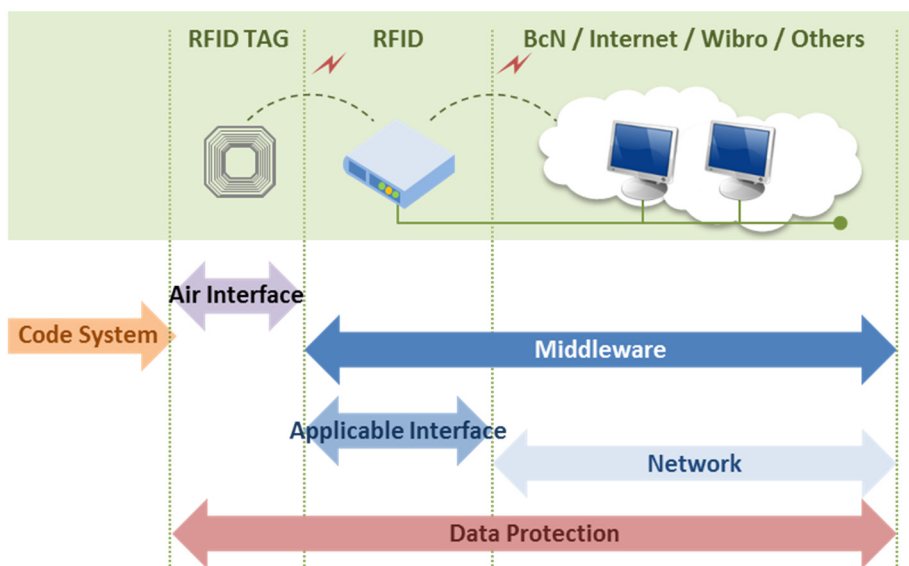
An RFID system comprises a number of elements:

- **RFID reader / writer:** The reader writer is used to communicate with the tags that may pass within range. The RFID reader writer will normally be located in a fixed position and will be used to interrogate an RFID tag. Dependent upon the application and the format of the system and the RFID reader / writer, data may also be written to the RFID tag.
- **RFID tag:** RFID tags may also be called RFID transponders and are typically located on items that are mobile. They are small and generally cheap so that they can be attached to low cost (or high cost) items that need to have information associated with them. They are also generally considered as being disposable. The RFID tag contains data that is relayed to the reader, and in some systems it may also be possible to update the data within the tag to indicate that the tag and hence the item has undergone a specific stage in a process, etc.
- **RFID application software:** like all systems these days, RFID systems need application software to run the overall system. With many systems there will be a number of different reader / writers and the data to and from these needs to be coordinated and analyzed. A specific application software will be required for these.

Although each RFID system will vary according to its requirements, the aforementioned are the main elements which can be found.

RFID technology has become widespread in its use. It offers many advantages and RFID is a particularly versatile system, being able to be used in many areas from shops, to manufacturing plants and also for general asset tracking, as well as a host of other innovative applications.

The following diagram described the RFID elements:



Type	Details
Air Interface	Technical specifications regarding the wireless connection interface between the RFID tag and the reader
Code System	System of identifier codes to be recorded on RFID tags
Middleware	Common processing function of the applicable middleware system to apply various RFID

Type	Details
Applicable Interface	Interface for communication between the RFID reader and the applicable server system
Network	Network service function required in the applicable RFID service operation
Data protection	Data protection function required in the RFID tag/reader and applicable systems

Figure 37 – RFID Elements

### 2.3.3 Energy harvesting

Taking advantage of different forms of energy, or through strategies of collecting the passage of people, cars, differences in salinity, currents of air through small devices, etc., is something that should happen in a smart sustainable city. Energy harvesters also provide a very small amount of power for low-energy electronics. Many sensors related to IoT, for example could feed themselves the required energy units.

#### Role of the technology<sup>17</sup>

Environmental monitoring or reducing environmental burden of application areas using ICT in SSC requires sensing network to collect data used in those areas.

To reduce the environmental burden of the sensing network itself, it is required to lessen environmental burden of the sensing devices. Sensing networks generally use an enormous number of sensing devices.

#### Definition of the technology

Energy harvesting technology is the technology that derives energy from the surrounding environment (environmental energy), such as light, vibrations, heat and radio waves, and converts it into electricity in order to move sensing devices, process signals and convey data through wireless networks without being supplied with electricity from any external sources such as batteries. Using environmental energy allows us to save maintenance costs for power cables and the replacement of batteries.

Energy harvesting technology is composed of technology of generating electricity from environmental energy and that of storing the electricity that enables it to be used stably.

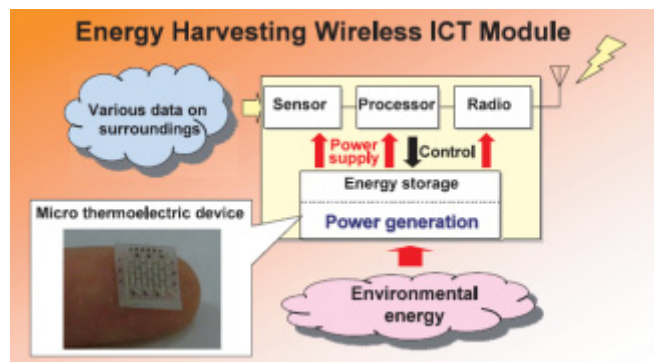


Figure 38 – Control Technology to prevent decreased CPU performance

<sup>17</sup> Corresponds to a contribution of FUJITSU (Japan) by document FG-SSC-0032

**Requirements of the technology**

- (i) To be able to harvest energy efficiently

It is required to be able to get a sufficient amount of electricity to move sensing devices, to process signals and to convey data through wireless networks. For instance, the amount of electricity produced is relatively small when only one kind of environmental energy source is used among light, vibrations, heat and radio waves. In contrast to this, when energy is derived from multiple environmental energy sources, a larger amount of electricity can be acquired.

- (ii) To be small and thin

Sensing devices are to be attached to various mobile objects including the human body and the number of them is to be enormous. It is required to be small and thin in order to be able to adapt to wide range of objects and to lessen the environmental burden as much as possible even if the number of them is huge. It is also required to be able to get enough output power even though they are small and thin.

- (iii) To be more durable

Since sensing devices are to be attached to various mobile objects including the human body, they are likely to be exposed to various environmental conditions. It is required that they do not malfunction easily even if they are moved or subject to a wide range of temperatures or moisture ranges.

- (iv) Not to use hazardous substances

The thermoelectric conversion is the direct conversion of temperature differences to electric voltage. A thermoelectric material creates a voltage when there is a different temperature on each side. The heavy metals such as bismuth telluride (Bi-Te) that have been used widely as the thermoelectric materials are toxic and not environmentally friendly. Such materials with large negative environmental impacts are not suitable for use in wireless ICT that is widely distributed to the environment. In contrast to this, for example, some oxide materials can be used as thermoelectric material with a small negative environmental impact.

**Examples of application area:**

- (i) Environmental monitoring area

To detect environmental change and occurrence of disasters using environmental sensors.

- (ii) Facility management area

To detect troubles in airplanes, automobiles or plants instantaneously.

- (iii) Healthcare area

To monitor the user's physical condition constantly by attaching a device to the user's skin, to provide health guidance from a Cloud application, and to automatically call for an ambulance in an emergency.

### 2.3.4 Internet of things

The reality described in the next paragraph reflects the importance of creating mega-connection for future cities: "In 2012, there were 8.7 billion connected objects globally, constituting 0.6% of the 'things' in the world. In 2013, this number is exceeding 10.0 billion. Driven by reducing price per connection and the consequent rapid growth in the number of machine-to-machine (M2M) connections, one expects the number of connected objects to reach 50bn by 2020 (2.7% of things in the world). The connectivity costs are expected to reduce at a rate of 25% CAGR during 2012-20, which is approximately equal to the growth in number of connected objects (implying price-elasticity demand of 1). Lastly, it is believed that more than 50% of the connected objects added during 2013-20 will be added in the last 3 years of the decade. This also implies that the maximum connected objects are likely to be added when the connectivity costs are the lowest"<sup>18</sup>.

Internet of things (IoT) is a network constituted by all kind of devices, sensors, terminals which can be part of a smart home, building, companies and SSC; which connect to each other mainly through the Internet.

The IoT will constitute the nervous system of SCC, support the interconnection and the continuous flow of information between the environment, machines, urban or rural infrastructure, and people. Besides the technology subjects discussed earlier, in this particular case, the availability of IP numbers that can be assigned to each "host" in the network is also importance. Hence this requires a closer view to IPV6 protocol.

The IoT is a widely used term for a set of technologies, systems, and design principles associated with the emerging wave of Internet-connected things that are based on the physical environment. In many respects, it can initially look, the same M2M communication – connecting sensors and other devices to Information and Communication Technology (ICT) systems via wired or wireless networks.

In contrast to M2M, however, IoT also refers to the connection of such systems and sensors to the broader Internet, as well as the use of general Internet technologies. In the longer term, it is envisaged that an IoT eco-system will emerge not dissimilar to today's Internet, allowing things and real world objects to connect, communicate, and interact with one another in the same way humans do via the web today. Increased understanding of the complexity of the systems in question, economies of scale, and methods for ensuring interoperability, in conjunction with key business drivers and governance structures across value chains, will create wide-scale adoption and deployment of IoT solutions.

No longer will the Internet be only about people, media, and content, but it will also include all real-world assets as intelligent creatures exchanging information, interacting with people, supporting business processes of enterprises, and creating knowledge. The IoT is not a new type of Internet network; it is an extension to the existing Internet.

IoT is about the technology, the remote monitoring, and control, and also about where these technologies are applied. IoT can have a focus on the open innovative promises of the technologies at play, and also on advanced and complex processing inside very confined and close environments such as industrial automation. When employing IoT technologies in more closed environments an alternative interpretation of IoT then is "Internet of Things".

---

<sup>18</sup> Cisco Connections Counter



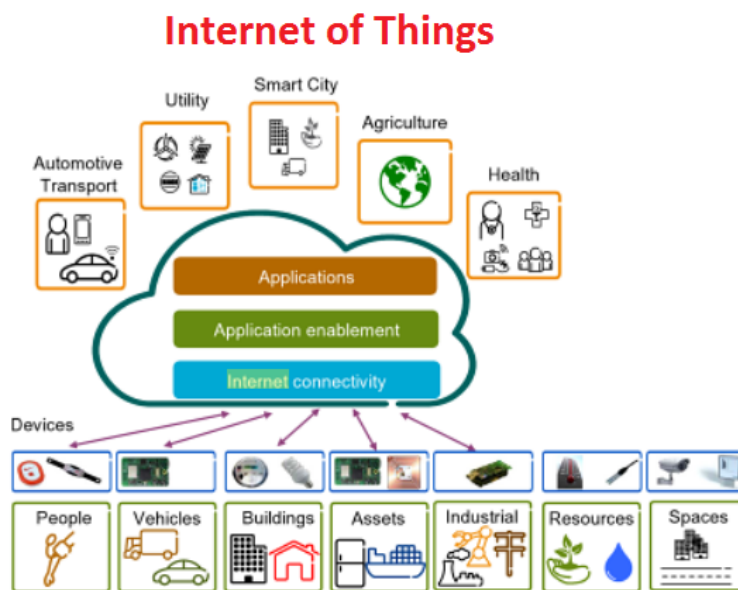


Figure 39 – Internet of Things<sup>19</sup>

These components could be summarize appealingly with a help of a simple equation:

$$\begin{array}{c}
 \textit{Physical Object} \\
 + \\
 \textit{Controller, Sensor, and Actuators} \\
 + \\
 \textit{Internet} \\
 = \\
 \textit{Internet of Things}
 \end{array}$$

*An equation for the Internet of Things*

Source: "Designing the Internet of Things". By Adrian MCEwen, Hakim Cassimaly

The IoT together with the other emerging Internet developments such as the Internet of Energy, Media, People, Services and Business/Enterprises, are the backbone of the digital economy, the digital society. The IoT developments show that there will be 16 billion connected devices by the year 2020, which will average out to six devices per person on Earth and to many more per person in digital societies. Devices like smart phones and machine to machine (M2M) (or thing to thing – ToT) communications will be the main drivers for further IoT development.

By 2015, wirelessly networked sensors in everything one owns will form a new Web. However, it will only be of value if the "terabyte torrent" of data it generates can be collected, analyzed and interpreted.

<sup>19</sup> Source: "From Machine-to Machine to the Internet of Things: Introduction to a New Age of Intelligence". By: Jan Holler, Vlasios Tsiatsis, Catherine Mulligan, Stefan Avesand, Stamatis Karnouskos, David Boyle.

The first direct consequence of the IoT is the generation of huge quantities of data, where every physical or virtual object connected to the IoT may have a digital twin in the cloud, which could be generating regular updates. As a result, consumer IoT related messaging volumes could easily reach between 1,000 and 10,000 per person per day.

The IoT contribution is in the increased value of information created by number of interconnections among things and the transformation of the processed information into knowledge for the benefit of mankind and society.

The IoT could allow people and things to be connected “Anytime, Anyplace, with Anything and Anyone”, ideally using Any path/network and Any service. This is also stated in the ITU vision of the IoT.

The vision of what exactly the Internet of Things will be, and what its final architecture will be, is still diverging and being researched on.

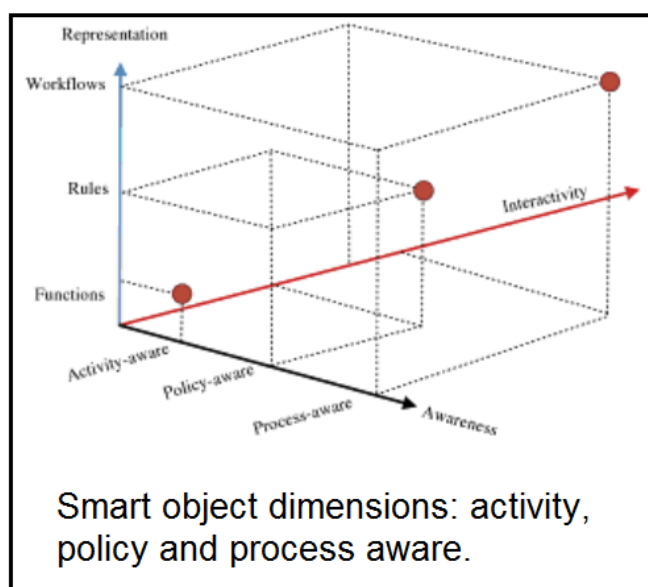


Figure 40 – Smart object dimensions<sup>20</sup>

### Internet-of-Things Architecture (IoT-A)<sup>21</sup>

The main aim of IoT-A can be explained using the pictorial representation that shown in the following Figure 38.

<sup>20</sup> Extracted of: Book: Internet of Things-Global Technological and Societal Trend, by Dr. Ovidiu Vermesan and Dr. Peter Friess.

<sup>21</sup> Extracted of document: Internet-of-Things Architecture IoT-A. Deliverable D1.3 –Updated reference model for IoT v1.5. Project co-funded by the European Commission within the Seventh Framework Programme (2007-2013).

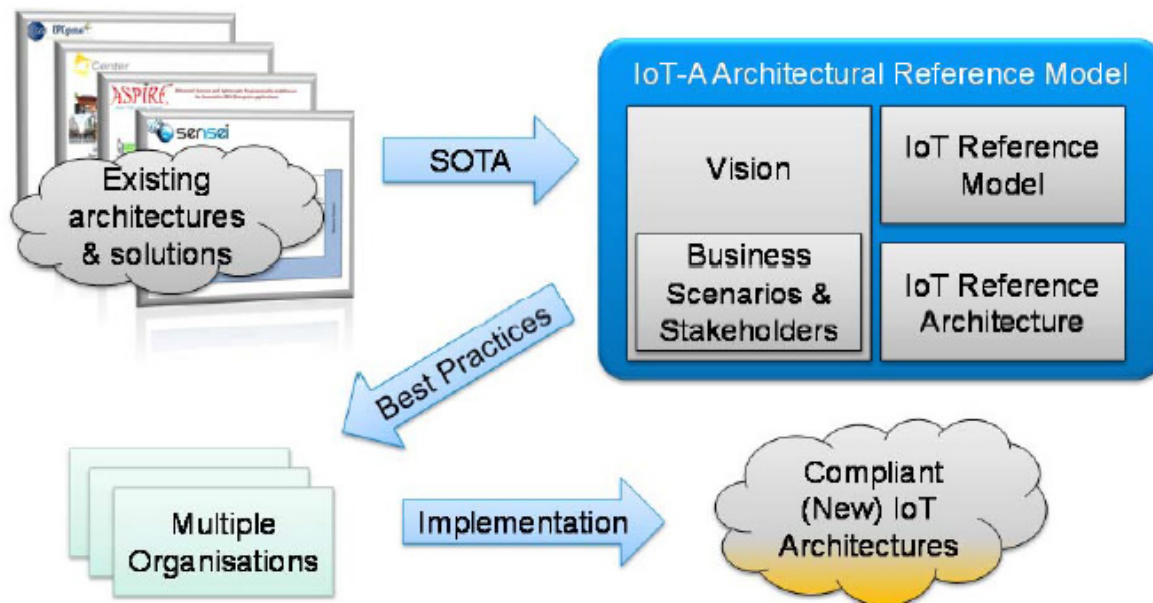


**Figure 41 – Pictorial representation of the aim of IoT-A**

As in any metaphoric representation, this tree does not claim to be fully consistent in its depiction, hence, it should therefore not be taken too strictly. On the one hand, the roots of this tree are spanning across a selected set of communication protocols (6lowpan, ZigBee, IPv6,...) and device technologies (sensors, actuators, tags,..) while on the other hand, the flowers/leaves of the tree represents the whole set of IoT applications that can be built from the sap (information/knowledge) coming from the roots. The trunk of the tree is of the utmost importance here, beyond the fact it represents the IoT-A project. This trunk represent the Architectural Reference Model (which means here Reference Model + Reference Architecture a.k.a. ARM), the set of models, guidelines, best practices, views and perspectives that can be used for building fully interoperable IoT Concrete architecture (and therefore systems). Using this tree, one aims at selecting a minimal set of interoperable technologies (the roots) and proposing the potentially necessarily set of enablers or building blocks, etc. (the trunk) that enable the creation of a maximal set of interoperable IoT systems (the leaves).

#### Reference model and reference architecture:

The IoT reference model provides the highest abstraction level for the definition of the IoT-A architectural reference model. It promotes a common understanding of the IoT domain. The description of the reference model includes a general discourse on the IoT domain, a domain model as a top-level description, an information model explaining how IoT knowledge is going to be modelled, and a communication model in order to understand interaction schemes for smart objects. The definition of the IoT reference model is conforming to the OASIS reference model definition [Mackenzie, 2006]. A more detailed description of the IoT reference model is provided in <http://www.ietf-a.eu/arm>.



IoT-A architectural reference model building blocks.

**Figure 42 – IoT-A architectural reference model building blocks**

The figure shows an overview of the process used for defining the different parts that constitute the IoT Architectural Reference Model (ARM). Notice that definitions of terms such as reference architecture, etc. The IoT-A ARM consists of four parts:

**(i) Vision:** The vision summarizes the rationale for providing an architectural reference model for the IoT. At the same time it discusses underlying assumptions, such as motivations.

**(ii) Business scenarios & stakeholders:** These are the drivers of the architecture work. With the knowledge of businesses aspirations, a holistic view of IoT architectures can be derived. Furthermore, a concrete instance of the reference architecture can be validated against selected business scenarios. A stakeholder analysis contributes to understanding which aspects of the architectural reference model need to be described for the different stakeholders and their concerns.

**(iii) IoT Reference Model:** The IoT Reference Model provides the highest abstraction level for the definition of the IoT-A Architectural Reference Model. It promotes a common understanding of the IoT domain. The description of the IoT Reference Model includes a general discourse on: (a) the IoT domain, (b) an IoT Domain Model as a top-level description, (c) an IoT Information Model explaining how IoT knowledge is going to be modeled, and (d) an IoT Communication Model in order to understand specifics about communication between many heterogeneous IoT devices and the Internet as a whole.

**(iv) IoT Reference Architecture:** The IoT Reference Architecture is the reference for building compliant IoT architectures. As such, it provides views and perspectives on different architectural aspects that are of concern to stakeholders of the IoT.

### The IoT Domain Model<sup>22</sup>:

The relation between Virtual and Physical Entity is usually achieved by embedding into, by attaching to, or by simply placing in close vicinity of the Physical Entity one or more ICT Devices that provide the technological interface for interacting with or gaining information about the Physical Entity. By so doing the Device actually enhances the Physical Entity and allows the latter to be part of the digital world. This can be achieved by using Devices of the same class, as in the case of body-area network nodes, or by using Devices of different classes, as in the case of an RFID tag and reader. A Device thus mediates the interactions between Physical Entities (that have no projections in the digital world) and Virtual Entities (which have no projections in the physical world), generating a paired couple that can be seen as an extension of either one. Devices are thus technical artifacts for bridging the real world of Physical Entities with the digital world of the Internet. This is done by providing monitoring, sensing, actuation, computation, storage and processing capabilities. It is noteworthy that a Device is also a Physical Entity and can be regarded as such, especially in the context of certain applications.

An example for such an application is device management, whose main concern is the devices themselves and not the objects or environments that these devices monitor.

From an IoT point of view, the following three basic types of Devices are of interest:

**Sensors:** These provide information about the Physical Entity they monitor. Information in this context ranges from the identity of the Physical Entity to measures of the physical state of the Physical Entity. Like other Devices, they can be attached or otherwise embedded in the physical structure of the Physical Entity, or be placed in the environment and indirectly monitor entities. An example for the latter is a face-recognition enabled camera. Information from sensors can be recorded for later retrieval.

**Tags:** These are used to identify Physical Entities to which they are usually attached to. The identification process is called "reading" and it is carried out by specific sensor Devices, which are usually called readers. The sole purpose of tags is to facilitate and increase the accuracy of the identification process. This process can be optical, as in the case of barcodes and QR code, or it can be RF-based, as in the case of microwave car-plate recognition systems and RFID. The actual physics of the process as well as the many types of tags are however irrelevant for the domain model as these technologies vary and change over time. These are important however when selecting the right technology when implementing a concrete system.

**Actuators:** They can modify the physical state of a Physical Entity, like changing the state (translate, rotate, stir, inflate, switch on/off.) of simple Physical Entities or activating/deactivating functionalities of more complex ones.

The following figure shows the relationship between Augmented, Physical and Virtual Entities, together with other terms and concepts.

Hardware concepts are shown in blue, software in green, animated objects in yellow, and concepts that fit into either multiple or neither categories in brown.

<sup>22</sup> <http://www.ietf.org/rfc/rfc2222.txt>

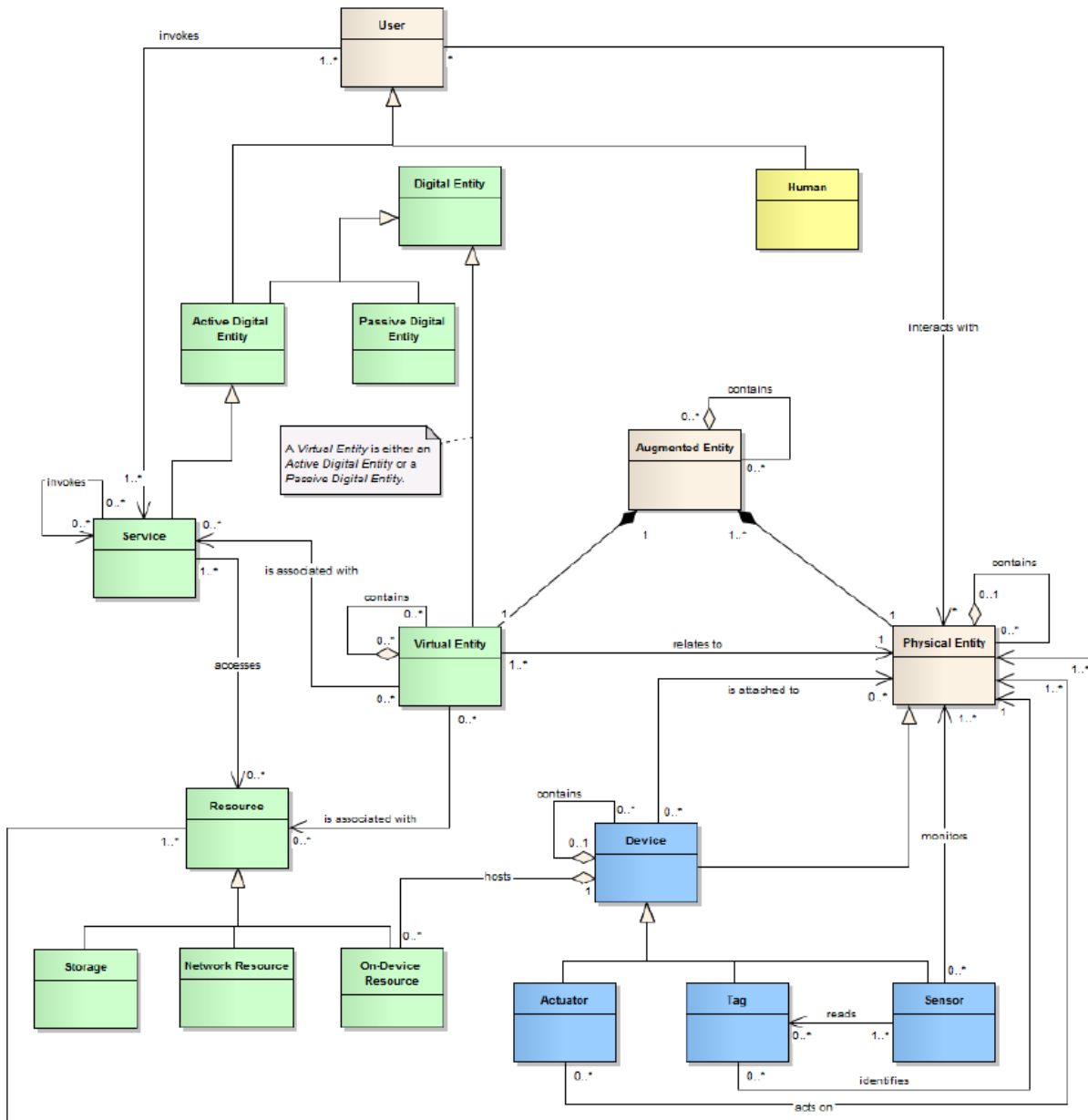


Figure 43 – IoT Domain Model<sup>23</sup>

IEEE P2413™ Working Group (WG), Internet of Things (IoT)<sup>24</sup>:

Scope and Purpose

IEEE P2413™ Standard for an Architectural Framework for the Internet of Things (IoT) defines an architectural framework for the Internet of Things (IoT), including descriptions of various IoT domains, definitions of IoT domain abstractions, and identification of commonalities between different IoT domains. The architectural framework for IoT provides a reference model that defines relationships among various IoT verticals (e.g., transportation, healthcare, etc.) and common architecture elements.

<sup>23</sup> [www.iot-a.eu/public/public-documents/d1.2](http://www.iot-a.eu/public/public-documents/d1.2)

<sup>24</sup> [http://standards.ieee.org/email/2014\\_06\\_cfp\\_p2413\\_web.html](http://standards.ieee.org/email/2014_06_cfp_p2413_web.html)



It also provides a blueprint for data abstraction and the quality "quadruple" trust that includes protection, security, privacy, and safety. Furthermore, this standard provides a reference architecture that builds upon the reference model. The reference architecture covers the definition of basic architectural building blocks and their ability to be integrated into multi-tiered systems. The reference architecture also addresses how to document and, if strived for, mitigate architecture divergence. This standard leverages existing applicable standards and identifies planned or ongoing projects with a similar or overlapping scope.

This standard will help to reduce current fragmentation in the various IoT verticals. By addressing the need for an IoT architectural framework, IEEE will fulfill its mission to benefit humanity by increasing the interoperability and portability of IoT solutions to both the industry and the end consumer.

### IP for things

If, in a future Internet of Things, everyday objects are to be addressed and controlled via the Internet, then one should ideally not be resorting to special communications protocols as is currently the case with RFID. Instead, things should behave just like normal Internet nodes. In other words, they should have an IP address and use the Internet Protocol (IP) for communicating with other smart objects and network nodes.

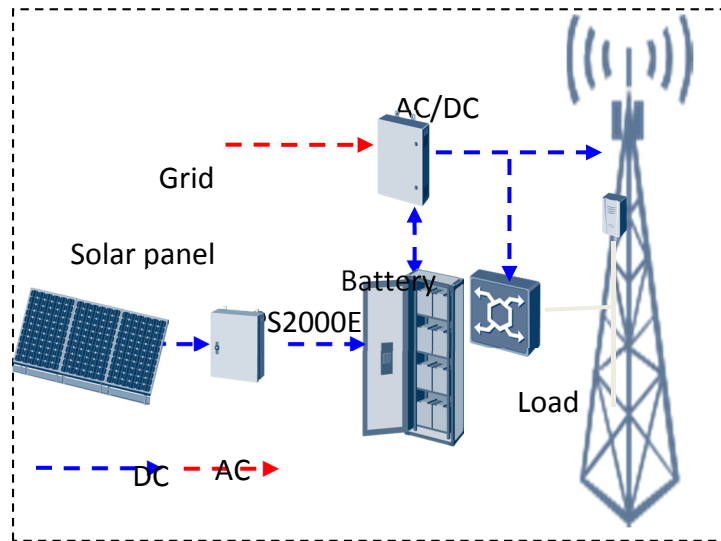
The benefits of having IP-enabled things are obvious, even if the objects in question are not going to be made globally accessible but instead used in a controlled intranet environment. This approach enables us to build directly on existing functionality such as global interoperability, network-wide data packet delivery (forwarding and routing), data transport across different physical media, naming services (URL, DNS) and network management. The use of IP enables smart objects to use existing Internet services and applications and, conversely, these smart objects can be addressed from anywhere since they are proper Internet participants. Last but not least, it will be easy to use important application layer protocols such as HTTP.

## 2.4 Energy efficiency of ICT infrastructure

ICT infrastructure need built considering the environmental impact of the ICT itself in a way that the environmental benefit of using ICT in other sectors will be not lower that the impact generates by the ICT infrastructure.

Technological solutions like power the infrastructure equipment using sustainable sources need to be considered when possible.

For example, a solution as reported in the figure can be implemented considering the impact on fossil generated energy reduction and also the impact on operation cost.



**Figure 44 – Example of radio site powered by AC main and solar energy**

The equipment used to build the ICT infrastructure need to be high efficiency equipment to reduce their impact and energy consumption respect to their use.

Definition of energy efficiency metrics for ICT is available in ITU-T Recommendation L.1310 "Energy efficiency metrics and measurement methods for telecommunication equipment<sup>25</sup>". This Recommendation also specifies the principles and concepts of energy efficiency metrics and measurement methods for small networking equipment used in the home and small enterprise locations. The Recommendation defines that when transmission time and frequency bandwidth are fixed, a telecommunication system that can transport more data (in bits) with less energy (in Joules) is considered to be more energy efficient.

The efficiency of infrastructure equipment is considered in ITU-T Recommendation L.1320: "Energy efficiency metrics and measurement for power and cooling equipment for telecommunications and data centers<sup>26</sup>". The methodologies defined in this Recommendation are applied at single equipment level. The efficiency of power conversion and cooling in the data center or telecommunication facility is only partially attributed to the equipment. The architecture and organization of the space and equipment to deliver the power or cooling to the systems is an equal, if not a more significant factor to energy efficiency. Another general factor will be the

<sup>25</sup> Recommendation ITU-T L.1310 contains the definition of energy efficiency metrics test procedures, methodologies and measurement profiles required to assess the energy efficiency of telecommunication equipment. Energy efficiency metrics and measurement methods are defined for telecommunication network equipment and small networking equipment. These metrics allow for the comparison of equipment within the same class, e.g., equipment using the same technologies.

<sup>26</sup> Recommendation ITU-T L.1320 contains the general definition of metrics, test procedures, methodologies and measurement profiles required to assess the energy efficiency of power and cooling equipment for telecommunications and data centers. More detailed measurement procedures and specifications can be developed in future related ITU-T Recommendations. Metrics and measurement methods are defined for power equipment, alternating current (AC) power feeding equipment (such as AC uninterruptible power supply (UPS), direct current (DC/AC) inverters), DC power feeding equipment (such as AC/DC rectifiers, DC/DC converters), solar equipment, wind turbine equipment and fuel cell equipment. In addition, metrics and measurement methods are defined for cooling equipment such as air conditioning equipment, outdoor air cooling equipment and heat exchanging cooling equipment.

interoperability, management, and response of these systems across the demand and operational range.

Some reference values for the metrics defined in ITU-T are available in L.1340: "Informative values on the energy efficiency of telecommunication equipment<sup>27</sup>".

The growing demand for Internet connections from both governments and citizens is driving the rapid increase in worldwide deployment of broadband and ultra-broadband networks. Depending on the specific geographic, demographic and economic conditions, such networks can be either fixed (based on FTTx architectures and implementing technologies such as ADSL, ADSL2plus, VDSL2, GPON, GEPON, etc.) or mobile (based on HSPA, LTE, UMTS, etc.).

The increasing deployment of broadband and ultra-broadband networks has a real impact on energy consumption and, in more general terms, on the carbon footprint. To address the critical issue of energy efficiency, it is essential that particular attention be given to the choice of specific technologies during the planning phase. An informed choice of available energy-efficient telecommunication equipment is fundamental to reducing energy consumption while guaranteeing the desired level of quality of service (QoS) and reliability.

Recommendation ITU-T L.1340 provides informative values on the energy efficiency of different types of telecommunication network equipment and small networking equipment used in both the fixed and mobile networks.

**Informative values for digital subscriber line access multiplexer (DSLAM), multi-service access code (MSAN) and optical line termination (OLT) equipment<sup>28</sup>:**

This clause defines the informative values with respect to the energy efficiency metrics defined for the specific technologies used by DSLAM, MSAN and OLT equipment. More precisely, this clause covers the:

- DSLAM equipment and MSAN equipment implementing ADSL2plus, VDSL2 and POTS technologies.
- OLT equipment implementing the gigabit passive optical network (GPON), gigabit Ethernet passive optical network (GEPON) and point-to-point (PtP) technologies.

For these equipment typologies, the most commonly used metric is the Pport, which considers the number of ports at a fixed load as a functional unit.

$$P_{port} = P_{EQ} / N_{ports} \quad [\text{W/port}]$$

Where:

PEQ is the power (in Watts) of a fully equipped wireline network equipment with all its line cards working in a specific profile or state (e.g., all VDSL2 subscriber lines in LO state, all ADSL2plus

<sup>27</sup> Recommendation ITU-T L.1340 provides informative values on the energy efficiency of different types of telecommunication network equipment and small networking equipment in use in both the fixed and mobile networks. These values are related to energy efficiency metrics, test procedures, methodologies and measurement profiles that have been defined in Recommendation ITU-T L.1310. These informative values are intended to be a valued reference resource for those in the process of choosing the most energy-efficient technologies for network upgrade and deployment and, in so doing, reducing the carbon footprint of the Information and Communication Technology (ICT) sector.

<sup>28</sup> ITU-T L.1340 "Informative values on the energy efficiency of telecommunication equipment"

subscriber lines in L2 state). For DSL line cards that have additional functions (e.g., MELT, vectoring, test access and channel bonding, etc.), in addition to the bare DSL functionality, the informative value for such boards refers to a normal DSL mode of operation with any additional functions being disabled.

Rec. ITU-T L.1340 (02/2014) 5 Nports is the maximum number of ports served by the broadband network equipment under test.

**Table 3 – Informative values for DSLAM/MSAN**

**Informative values for DSLAM/MSAN in L0 mode**

Specific technology for DSLAM/MSAN (L0 mode)	Informative value in L0 for equipment with more than 96 ports (W/port)	Informative value in L0 for equipment with less than 96 ports (W/port)
ADSL2plus (including ADSL and ADSL2 and with transmission power of 19.8 dBm)	1.2	1.5
VDSL2 (profile 8b) transmission power 19.8 dBm	1.8	2.1
VDSL2 (profile 12a and 17a) transmission power 14.5 dBm	1.6	1.9
VDSL2 (profile 30a) transmission power 14.5 dBm	2.0	2.3
POTS (off-hook) (see Note)	2.0	2.3
NOTE – It is assumed that power consumed by the MSAN functionality which is common to both DSL and POTS is split appropriately across the two functions. For those boards, such as combo interface board and combo main control board, which integrate DSL and POTS functions, the informative values of these boards are assumed to be measured separately for each function, i.e., measure broadband with POTS disabled and vice versa.		

**Informative values for DSLAM/MSAN in L2 mode**

Specific technology for DSLAM/MSAN (L2 mode)	Informative value in L2 for equipment with more than 96 ports [W/port]	Informative value in L2 for equipment with less than 96 ports [W/port]
ADSL2plus (including ADSL and ADSL2)	0.8	1.1
VDSL2 (profile 8b, 12a, 17a and 30a)	1.2	1.5
POTS (on-hook)	0.5	0.8

**Informative values for DSLAM/MSAN in L3 mode**

Specific technology for DSLAM/MSAN (L3 mode)	Informative value in L3 for equipment with more than 96 ports [W/port]	Informative value in L3 for equipment with less than 96 ports [W/port]
ADSL2plus (including ADSL and ADSL2)	0.4	0.7
VDSL2 (profile 8b, 12a, 17a and 30a)	0.6	0.9

**Table 4 – Informative values for OLT**

<b>Informative values for OLT in L0 mode</b>		
Specific technology for OLT (L0 mode) (see Note)	Informative value for equipment with more than 32 ports [W/port]	Informative value for equipment with up to 32 ports [W/port]
G-PON (2.5G/1G) implementing standard Layer 2 (Ethernet) aggregation functionalities, including Multicast	11	12
G-PON (2.5G/1G) implementing also functionalities at the IP layer such as routing, MPLS and IP QoS, or more advanced Layer 2 functionality (QoS, shaping, policing)	12	13
1G-EPON (1G/1G) implementing standard Layer 2 (Ethernet) aggregation functionalities, including Multicast	7	8
1G-EPON (1G/1G) implementing also functionalities at the IP layer such as routing, MPLS and IP QoS, or more advanced Layer 2 functionality (QoS, shaping, policing)	8	9
1G-EPON (1G/1G) without Layer 2/Layer 3 aggregation functionality with 16 ports	–	13.4
10G-EPON (10G/1G) implementing standard Layer 2 (Ethernet) aggregation functionalities, including Multicast	15	16
10G-EPON (10G/1G) implementing also functionalities at the IP layer such as routing, MPLS and IP QoS, or more advanced Layer 2 functionality (QoS, shaping, policing)	16	17
10G-EPON (10G/10G) implementing standard Layer 2 (Ethernet) aggregation functionalities, including Multicast	16	17
10G-EPON (10G/10G) implementing standard Layer 2 (Ethernet) aggregation functionalities, including Multicast	17	18
PtP (1G)	2.5	4.5
PtP (10G)	18	30
NOTE – The informative values for G-PON, 1G-EPON and 10G-EPON OLT are assumed to be per port whatever the number of ONU connected to it is. The values for G-PON OLT are with Class B+ (Appendix III to [b-ITU-T G.984.2]) optical modules. Informative values reported for 10G-EPON type applies to IEEE 1904.1 Package C compliant systems.		

Equipment test methodologies for MSAN, DSLAM and OLT equipment have been defined in [ITU-T L.1310].

**Informative values for wireless access technologies**<sup>29</sup>: This clause defines the informative values with respect to the energy efficiency metrics defined for the following radio access technologies: GSM/EDGE, WCDMA/HSDPA, WiMAX and LTE.

<sup>29</sup> ITU-T L.1340 "Informative values on the energy efficiency of telecommunication equipment"



**Table 5 – Informative values for GSM/EDGE/WCDMA/HSDPA/WIMAX/LTE****Informative values for GSM/EDGE network equipment**

GSM/EDGE network equipment (see Note)	Informative value [W]	
	0.9/1.8/1.9 GHz	
GSM/EDGE radio base station (3 sectors) – full-load state	950	
GSM/EDGE radio base station (3sectors) –medium-load state	750	
GSM/EDGE radio base station (3sectors) – low-load state	600	
NOTE – Three sectors, four carriers per sector (S444).		

**Informative values for WCDMA/HSDPA network equipment**

WCDMA/HSDPA network equipment (see Note)	Informative value [W]	
	2.1 GHz	
WCDMA/HSDPA radio base station (3 sectors) – full-load state	900	
WCDMA/HSDPA radio base station (3 sectors) – medium-load state	780	
WCDMA/HSDPA radio base station (3 sectors) – low-load state	690	
NOTE – 3 sectors, 2.1 GHz, two carriers per sector (S222).		

**Informative values for WiMAX network equipment**

WiMAX network equipment (see Note)	Informative value [W]	
	2.5 GHz	3.5 GHz
WiMAX radio base station (3 sectors) – full-load state	640	610
WiMAX radio base station (3 sectors) – medium-load state	570	550
WiMAX radio base station (3 sectors) – low-load state	480	460
NOTE – 3 sectors, 2.5 GHz/3.5 GHz, 10 MHz bandwidth channel, 4 × 4 MIMO, 29:18 DL/UL sub-frame ratio.		

**Informative values for WiMAX network equipment**

LTE network equipment (see Note)	Informative value [W]	
	2.6 GHz	
LTE radio base station (3 sectors) – full-load state	1100	
LTE radio base station (3 sectors) – medium-load state	950	
LTE radio base station (3 sectors) – low-load state	750	
NOTE – 3 sectors, 2.6 GHz, 20 MHz bandwidth channel 2 × 2 MIMO.		

The impact of ICT infrastructure could also be verified as global impact not considering only the energy consumption but also the total foot print using methodology that estimate the GHG emission of an equipment, network and service.



ITU-T Recommendation L.1410 provides a "Methodology for environmental life cycle assessments of information and communication technology goods, networks and services <sup>30</sup>". This Recommendation is part of a series of Recommendations dealing with the environmental impact assessment of ICTs.

Recommendation ITU-T L.1400 "Overview and general principles of methodologies for assessing the environmental impact of information and communication technologies" provides a general framework and guidance and describes the full series. This Recommendation has been developed to complement ISO 14040 and ISO 14044 for the assessment of the life cycle impact of ICT goods, networks and services. It focuses on the assessment of energy consumption and greenhouse gas (GHG) emissions.

The development of ICTs has led to concerns regarding its environmental impact. Taking into consideration the on-going efforts within the United Nations Framework Convention on Climate Change [b-UNFCCC] to combat climate change, ITU-T decided to develop an internationally agreed methodology to help the ICT sector to assess the environmental impact of ICT goods, networks and services, focusing on energy consumption and GHG emissions.

## 2.5 Example of designing an open access network for smart cities

### 2.5.1 Background

Establishing the "Smart Cities" is a biggest trend around the globe in Developed countries. The concept of the smart cities is to deploy advanced Voice, Data, Video and Control & Management Communication Systems and provide high tech connectivity services to residential and Business users and at the same time deploy hi-tech city management and community information portals. World's great economies like Middle Eastern Countries have already started working on developing Smart Cities and couple of projects execution is in progress. At the same time it has become a normal practice to receive RFPs for Telecom and Network parts of Smart Cities from different Governments and Organizations.

In this document an effort has been made to share some experience which has been learnt while designing and planning Smart City Network Solutions in Saudi Arabia. Although this is a huge topic and it is difficult to explain all the details on few pages, efforts have been made to convey high level information which can be useful for Product and Solution Managers.

### 2.5.2 Needs and challenges

The major focus here is on the Communication Network Part of the Smart Cities Projects. Although there are different approaches in deploying Communication network for residential and business users e.g., Active Ethernet, PON Networks etc. but GPON is the choice of most of the Network operators around the globe. Although there are different pros and cons of the two solutions but GPON is the choice of majority of the operators due to its Economy of Scale and Ease of Deployment and Management.

---

<sup>30</sup> This Recommendation provides specific guidance on energy and greenhouse gas (GHG) impacts. Recommendation ITU-T L.1410 is organized in two parts: Part I (clause 5) – ICT life cycle assessment: framework and guidance. Part I deals with the life cycle assessment (LCA) methodology applied to ICT goods, networks and services (ICT GNS). Part II (clause 6) – Comparative analysis between ICT and a reference product system (baseline scenario); framework and guidance. Part II deals with comparative analysis based on LCA results of an ICT GNS product system and a referenced product system.

In Smart cities, Network operators generally prefer to deploy open access network and try not to be responsible for service delivery to the end subscriber. They opt to go with Open Access network approach which can be utilized to provide connectivity to the end users for multiple Service providers. For example this will be a type of Network which can be used to deliver HSI (high speed internet) service from one Service Provider and Voice service from another Service provider to a single user or the user can opt to go with all triple play services from single Service provider.

The Biggest challenge in designing such networks is that the Network components and equipment must be able to support the features and functionalities that can help in separating and segregating different types of services from different service providers being delivered to different subscribers.

Designing an Open Access Network is a bit different than a normal FTTX Network. It is generally assumed that a network planned for triple play services using GPON technology can be utilized as an Open Access Network. We need to understand that this is not completely true. Generally the Networks deployed by Telecom Operators are not Open Access Network and the reason behind is that the Telecom Operators are themselves responsible for the service delivery and want full control over their deployments. They do not take service from other operators and serve their users. Actually the complete end-to-end network and service delivery is managed by single Network Operator. Such networks do not fall under the category of Open Access Networks. While Designing the Open Access Networks it must be kept in mind that not all OLTs, ONTs, Routers and Switches support Open Access Network Feature. There are limited no of devices which can be utilized for such deployments. Product selection is very critical and any mistake during this stage can be devastating at later stages.

### 2.5.3 About Open Access Network

Open Access provides a network business model that separates the physical bearer network from the service network. The infrastructure of an Open Access network, including passive infrastructure (optical fibers, equipment room premises, and cables) and active network devices, is built by an operator. Retail service providers (RSP) directly lease bandwidth on the infrastructure network to provide service packages to end subscribers.

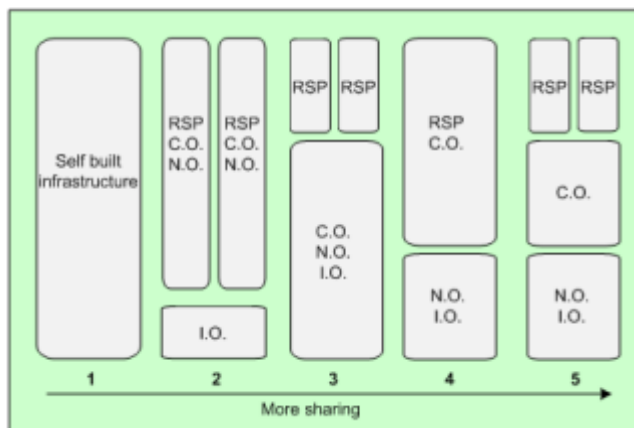
In the conventional model, an operator builds and operates its network and delivers services to end-users. Unlike the conventional model, Open Access builds a layered network over which separate Service Providers deliver their services.

Open Access brings the following benefits:

- Maximizes the freedom of choice for end users. End-users have more services to choose from and can even switch from one service provider to another without changing their home terminals (such as their ONTs).
- Lowers investment risks for Retail Service Providers. The business model of Open Access greatly shortens the cycle of return on investment (ROI). The traditional business model of operators, who usually have monopoly over their networks, requires an ROI cycle of 8-10 years. The Open Access business model shortens the ROI cycle to 1-2 years. Hence Open Access lowers the investment entrance level and risks for RSPs, and promotes competition and innovation.
- Opens up a wider arena for RSPs. RSPs no longer need to build the infrastructure network and are able to focus on innovation and competition of services and contents.

### 2.5.4 Solution High Level Details

There are different models of deploying Open Access Networks as shown in the diagram below but Model-3 is the most common in Middle East.



**Figure 45 – Models of deploying Open Access Networks**

In this diagram:

Infrastructure operator (IO): who operates utilities such as ducts and wire poles.

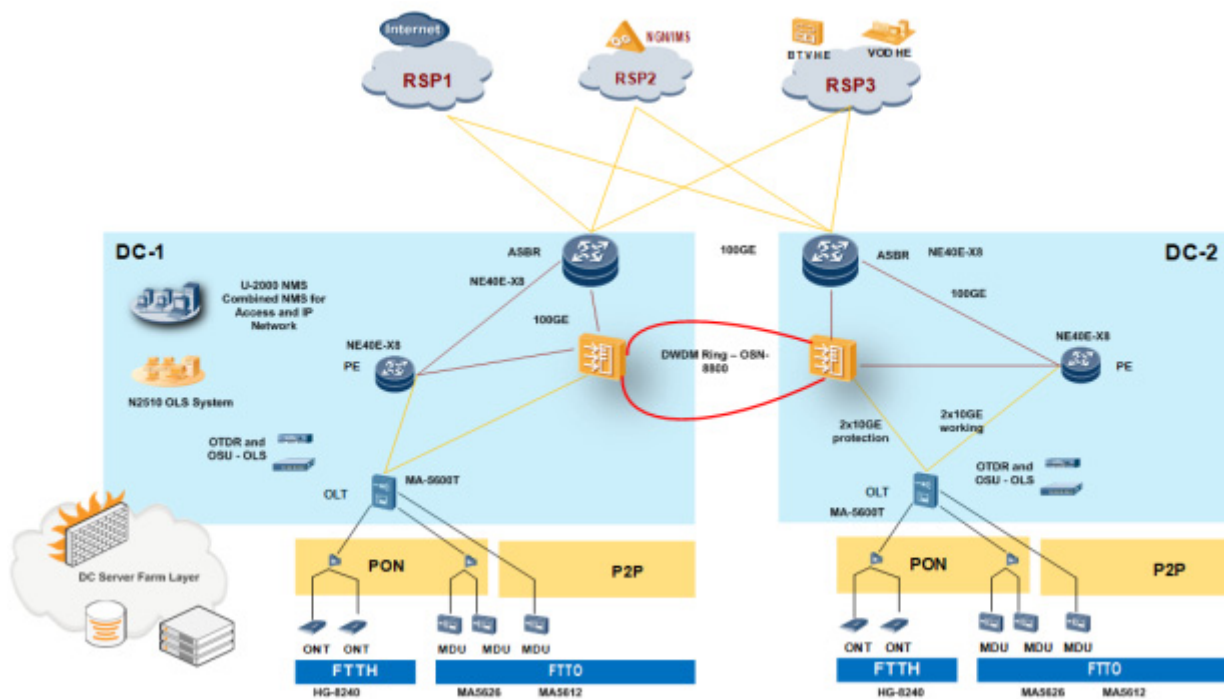
Network operator (NO): who operators resources such as optical cables.

Communications operator (CO): who operates active equipment, such as optical line terminals (OLTs) and optical network terminals (ONTs) on the network.

Retail service providers (RSPs): who retail services such as data, voice and video services.

In the model-3, Communication Operations (CO), Network Operations (NO) and Infrastructure operations (IO) are managed by the Main Network Owner and only Services are provided by the external Retail Service Providers.

This brief study focuses on CO part in the following sections. The most common Open Access Network CO architecture for the Smart Cities is shown in the Diagram below.



**Figure 46 – The most common Open Access Network CO architecture for Smart City**

The Network can be divided into following components:

- 1 GPON Network
- 2 IP-MPLS Backbone Network
- 3 Transmission Network
- 4 ODN Network
- 5 Network Management System

Additionally, QoS, Security, VLAN, Redundancy, Service Provisioning, Network Monitoring and Fault Management are the features which need to be considered while designing the Network.

### 2.5.5 GPON Network

GPON Network in Open Access Network is based on standard GPON Solution. GPON Ports, Boards (OLT dimensioning) is done based on standard procedures for GPON Network Design. Type-B Protection is preferred choice of the operators for GPON Network. One important and major difference than the conventional GPON Network is the ONT at subscriber site. There are limited ONTs which can be used for Open Access Model. ONT models are given below. Please consider this point while deciding ONTs for your network.

Another important point is that every Service Provider has to provide its own Home Gateway or Residential gateway which will be connected with ONT to provide the services which have been subscribed by the end user to that particular RSP. In Standard Open Access Network ONTs provided by Network Operators are demarcation points for RSPs and Network Operator's Network and actual Services are not provided by the ONTs provided by Network operators. Anyhow there are scenarios where Network's operator's ONT can be used for service provisioning but there are limitations in this scenario. Generally ONTs provided by Network Operators are run in Bridge Mode and Routing, NATing, Wi-Fi, Security and Voice Services are provided by HG/RG owned and managed by RSPs.

While Planning for Service provisioning and Network Operations, Demarcation points should be clearly defined between RSPs and Network operators.

Business Users are generally provided GE level connectivity and P-to-P connectivity is provided by OLTs Ethernet Boards. Redundant connectivity is provided using 2 ports on OLT and it is preferred to use single fiber bidirectional solution to save the fiber required for Business Users connectivity. To provide connectivity to Business Users MDUs are preferred choice at customer end, as they provide abundant types of interfaces for Voice, Data and Video Transmission. In Scenarios where end Business user only requires Ethernet, specialized Ethernet switches can be utilized easily.

The following table contains an example of an Open Access Network design (including GPON).

**Table 6 – Contains an example of an Open Access Network design**

Classification	Example of Product or Hardware	Description
OLT	Infrastructure Access network equipment	Large-capacity OLT
	Infrastructure Access network equipment	Medium-capacity OLT
ONT	Homegateway equipment	Bridging+voice type, providing two POTS ports and four GE ports.
	Homegateway equipment	Bridging type, providing four GE ports.
Hardware dependency	Service CPU used for subsystem for control plane traffic processing (SPUA)	Use the SPUA board for upstream transmission when bandwidth control at RSP level or at RSP service level is required on the upstream ports of the OLT.

### 2.5.6 IP-MPLS Network Backbone Network

Following section discuss the IP-MPLS (Converged IP Network) part of the Network. The products which support Open Access Network IP-MPLS Network include:

**Table 7 – Products which support Open Access Network IP-MPLS Network**

Network Layer	Equipment Role	Functionality	
Aggregation network	AGG-LSW	The AGG-LSW aggregates enterprise users' services from ACC-LSWs/SBUs.	
	Access LAN switch (ACC-LSW)	The ACC-LSW provides Ethernet leased-line access services for corporations. It is connected to corporation CPEs.	
	User-facing provider edge (UPE)	The UPE is on the edge of the aggregation network, directly connected to the OLT or AGG-LSW.	
	AGG	The AGG is an aggregation switching device. It is directly connected to the BRAS.	
Backbone network	Provider Edge (PE)	The PE is on the edge of the backbone network, directly connected to the MAN.	
	Provider (P)	The P is a core device of the backbone network, and is connected to the PE and RPE.	
	RSP-end Provider Edge (RPE)	The RPE is connected to the RSP network.	

The L2/L3 hybrid bearer mode is used in the Open Access Network flexible aggregation/backbone layer scenarios. Residential HSI and VoIP services are transparently transmitted to RSP networks. Residential IPTV services are transmitted to the PE through L2VPN, and the PE forwards the services to the ASBR through L3VPN.



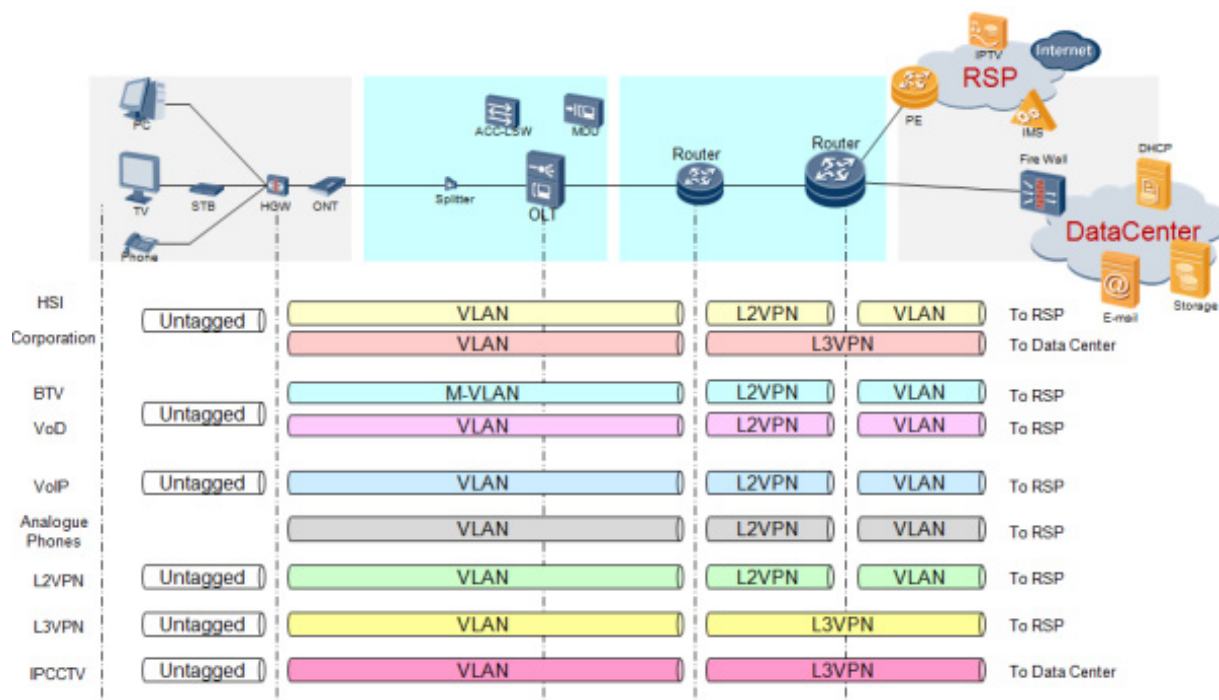


Figure 47 – Service Bearer Solution is given in the diagram below:

Complete Service Types supported by the Open Access Network are given below:

Table 8 – Complete Service Types supported by the Open Access Network

User Type	Service Type	Service Name
Residential user	High-speed Internet access service wholesale	HSI wholesale
	Voice service wholesale	VoIP wholesale
	IPTV service wholesale	Broadcast TV (BTV) wholesale
		Video on Demand (VoD) wholesale
Enterprise (either corporation or small-to-medium enterprise)	Dedicated Internet access (DIA) service wholesale	Corporation DIA wholesale
	L2VPN service wholesale	Point-to-point E-LINE wholesale
		Multipoint-to-multipoint E-LAN wholesale
	L3VPN service wholesale	L3VPN wholesale
Voice service wholesale	Corporation VoIP wholesale	

### 2.5.7 Transmission Network

The sole purpose of the transmission network in Smart City Network is to provide high capacity connectivity between different Datacenters and POPs where OLTs and other Access Aggregation equipments are installed. DWDM is the preferred technology with 100G, 40G and 10G Ethernet carrying Wavelengths. Additionally, DWDM can be deployed in Ring and Mesh to provide redundancy on Layer-0.

ODN Network consists of Fiber optic cables, ODFs, Cabinets, Splitters and related accessories. ODN network is designed to provide Type-B protected connectivity to the residential subscribers towards the OLTs at Aggregation and Datacenter Sites. Splitters with 1:32 split ratio are used to provide 80Mbps connectivity to residential subscribers.

OLS (Optical Line Supervisor) systems are deployed to monitor the fiber optic cable. Any fiber cuts occurring in the ODN Network are immediately identified by the OLS (e.g., N2510) system and field staff is informed to rectify the faults.

If Customer shows interest in Huawei's ODN Solution then iODN Solution should be presented. Generally it has been learnt that Network operator's do the design for ODN themselves or via some 3rd party consultants.

Business users are provided P-to-P connectivity to provide GE level connectivity on fiber. Redundant fibers are used to provide protected connectivity.

### 2.5.8 Network Management System

Open Access Network involves interoperation across carriers and wholesale of triple-play services. These scenarios require comprehensive network management and O&M solutions to ensure network manageability and maintainability. Smooth deployment of wholesale services and rapid fault locating has become major concerns.

The Network Management system is located at the NE management layer and the network management layer in the telecommunication management network (TMN). It has all NE-level and network-level management functions. Figure below, shows the positioning of the NM in the TMN.

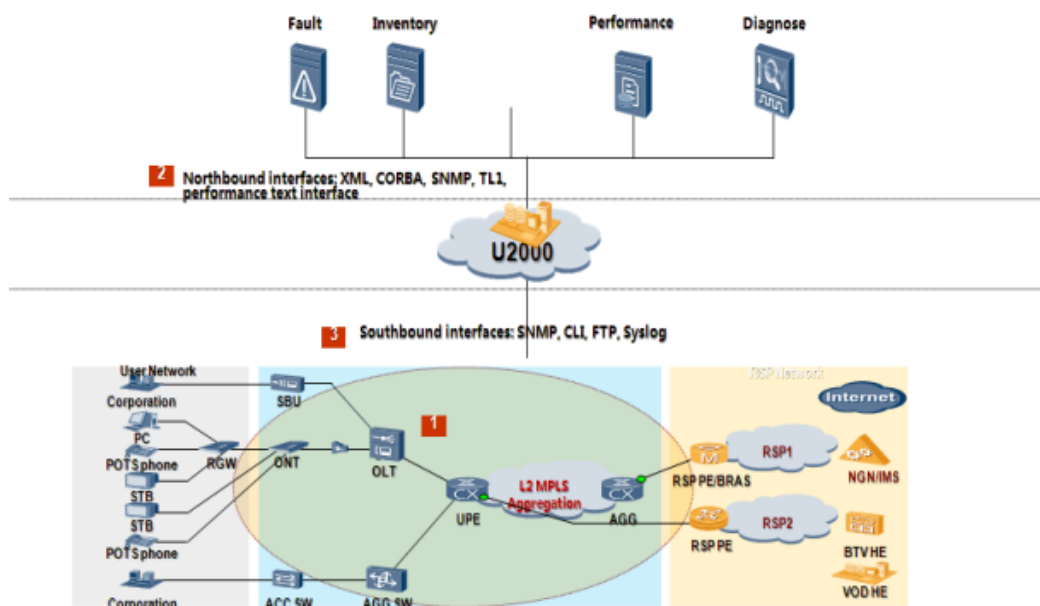


Figure 48 – Positioning of the NM in the TMN

The processes which need attention while planning NMS System include:

1. Service Rollout process for RSPs
2. Service Rollout process for Network Operators
3. Fault Locating Solutions
4. Alarm Management and Health Check

### 2.5.9 Other Design Areas and Considerations

While Designing the Open Access Network following areas need special attention and agreement with Customer/Network Operators:

1. VLAN Design: Broadband service types, user locations, and RSPs to which users belong are identified by VLAN. In this manner, packets are classified and separately transmitted, and QoS is performed.
2. IGP Routing Design: Depending on IGP section, may include OSPF or ISIS routing protocol.
3. BGP Routing Design: In the Open Access Network flexible aggregation/backbone layer scenario, BGP is used to transmit service routing information on the aggregation and backbone networks and between the Open Access Network and RSP network.
4. Multicast Routing: IPTV wholesale services are carried over multicast VPNs (MVPNs) on the metro aggregation and backbone networks. MVPN routes need to be deployed on the public network and VPNs.
5. MPLS Design: In the flexible open access network aggregation/backbone scenario, the aggregation and backbone devices are deployed in the same MPLS domain. All wholesale services except IPTV wholesale services are carried using MPLS on the aggregation and backbone networks.
6. Voice, HSI and IPTV Service Bearer Design.
7. Enterprise Solutions: E-Line, E-LAN and Layer-3 VPN Solution Design.
8. End-to-End Network Reliability Design.
9. QoS and Network Security Design.

## 2.6 Adaptation to Climate Change effect

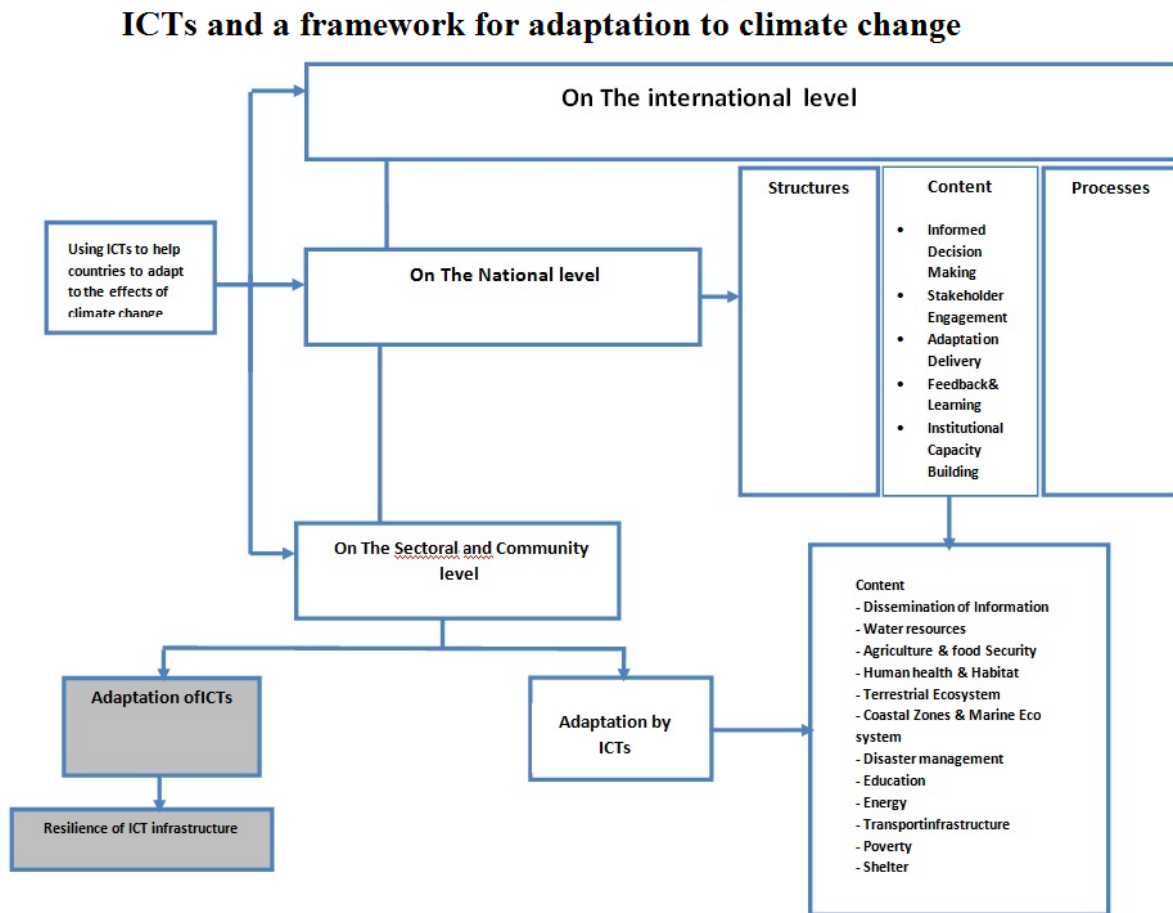
**2.6.1 Recommendation ITU-T L.1500** describes a framework for information and communication technologies (ICTs) and adaptation to the effects of climate change. This framework identifies and defines the basis for development of the following Recommendations:

- Recommendation ITU-T L.1501 on Best practices on how countries can utilize ICTs to adapt to the effects of climate change - on how ICTs can help countries to adapt to the effects of climate change. It also provides a framework and a checklist for countries to integrate ICTs into their national strategies for adaptation to climate change.
- Recommendation ITU-T L.1502 on Adapting information and communication technology infrastructure to the effects of climate change will provide a set of guidelines, requirements and best practices to be referred to during operation, maintenance, upgrade and improvement of existing infrastructure and when planning, designing and constructing ICT projects, goods and services to adapt to the effects of climate change.

The adverse effects of climate change pose a threat to the development and sustainability of the ICT sector and related sectors. To ensure sustainability of the ICT sector and other sectors it is

important to develop adaptation strategies to address the effects of climate change. There are key areas of action to be considered in the design of ICTs and climate change adaptation strategies, including policy development and the establishment of adequate structures and processes. At the sectoral level, sector-specific strategies need to be developed to ensure sustainable development in the face of climate variability and change.

ICTs therefore have a strategic role to play in ensuring the adaptability of other sectors. Furthermore, the ICT sector itself is vulnerable to the effects of climate change and should strategically evolve to adapt infrastructure to such changes. This can be done at several levels, from the international, national, sectoral and community level, as shown in the following figure.



**Figure 49 – ICTs and a framework for adaptation to climate change**

The differences in strategic approach at various levels, and between the ICT sector and other sectors, bring out a need for several adaptation approaches specific to the ICT sector and for countries to use.

### Climate change adaptation

This Recommendation proposes the development of the work in the following areas:

- Description of ITU-T Recommendation L-series on how ICTs can help countries to adapt to the effects of climate change. This Recommendation provides an overview of how ICTs can help countries to adapt to the effects of climate change. It will also provide a framework and a checklist for countries to integrate ICTs into their national strategies for adaptation to climate change. This Recommendation will be designed to assist countries in integrating ICTs into their national climate change adaptation strategies. Recently, the effects of climate change seem to

have grown quickly. In some cases it might already be too late or too costly to cope with the impact by improving the hardware, e.g., by making various social infrastructures physically strong, resilient and highly durable. It is therefore extremely important to make the best use of ICTs in saving human lives and minimizing social damages and difficulties.

- Description of ITU-T Recommendation L-series on how information and communication technologies (ICTs) can adapt to the effects of climate change. This Recommendation describes how information and communication technologies (ICTs) can adapt to the effects of climate change. It will provide a set of guidelines, requirements and best practices to be referred to during operation, maintenance, upgrade and improvement of existing infrastructure and when planning, designing and constructing ICT projects, goods and services to adapt to the effects of climate change.

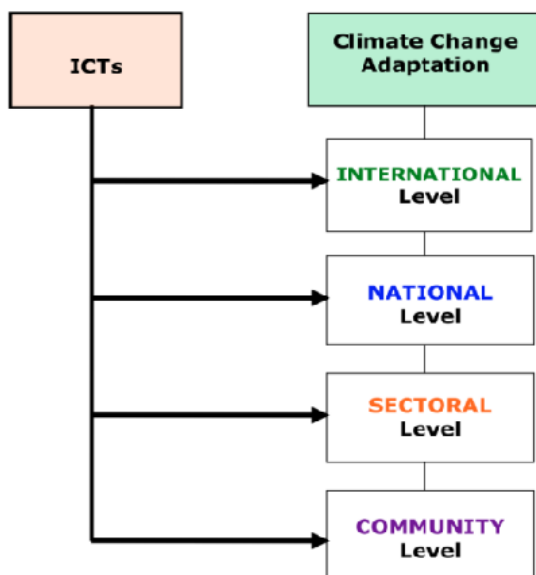
**2.6.2 Recommendation ITU-T L.1501** This Recommendation deals with how countries can utilize ICTs to adapt to the effects of climate change. It provides a framework for countries to integrate ICTs into their national strategies for adaptation to climate change.

The Recommendation also provides a checklist as an instrument for policy makers to ensure that they have the necessary pre-requisites to adapt the suggested framework in their national legislations, and enabling them to assess the adoption and implementation of the framework.

**Framework for ICTs and climate change adaptation**

The Recommendation provides the multi-level framework for ICTs integration in Climate Change adaptation for countries to integrate ICTs into their national climate change adaptation strategies.

The following figure shows the relation between ICTs and Climate Change adaptation.



Source: Bueti, C. (ITU), adapted from Ospina and Heeks (2011)

**Figure 50 – Framework for ICTs and Climate Change Adaptation**

## 3 Physical infrastructure and its intelligent upgrading

ICT infrastructure allows to improve appreciably and intelligently, the rest of major infrastructure of a city. This infrastructure also serves to deploy ICT networks and systems and it is organized in groups located in Layer 2 (non ICT-based Hard Infrastructure) and Layer 3 (ICT-based Hard Infrastructure) of SSC ICT Meta-Architecture (Figure 2)

The infrastructure concerns the following aspects:

- Water supply utilities, enhanced by smart water infrastructure;
- Energy supply utilities, upgraded with smart grids;
- Transportation networks, supported by intelligent transportation systems (ITS);
- Facilities for Health and care, supported by smart health systems;
- Safety and emergency infrastructure, accompanied by ICT for emergency management;
- Education and tourism facilities (i.e., schools and hotels), enhanced by corresponding ICT solutions;
- Buildings and smart buildings systems;
- Government infrastructure, upgraded by e-government solutions;
- Business facilities, streamlined and enhanced by e-business systems.

In fact, in addition to the traditional telecommunications networks deployed in cities, road infrastructure (rail and road), electrical lines, pipelines for hydrocarbons, gas distribution networks and water ducts can serve as support for greater deployment of such telecom networks.

Road networks often favor long distance telecom network deployments, as they facilitate the laying of fiber optic cables. There is greater diversity of deployments in urban areas, because operators use roads, as well as poles, sanitation ducts, etc. They usually use the streets as a guide to the communication networks.

### 3.1 Energy and water

#### 3.1.1 Smart energy

Smart grids are one of the main smart energy concepts that are developed to ensure: i) reliability, ii) self-healing, iii) interactivity, iv) compatibility, v) energy saving, vi) optimal use of energy from renewable sources, vii) safety, and viii) minimum carbon footprint.

#### Concerns about legacy ICT infrastructure for energy management

The operation of an electrical grid is a complex task driven by different needs: balancing the production and consumption of energy, maintaining the stability of frequency and voltage, protecting the electrical equipment against overcurrent and short circuits, assuring system reliability, restoring from disturbances (shunt faults, equipment failure with subsequent isolation, switching surges and lightning strikes, mechanical damages), etc.

Current electrical grids show quite a hierarchical structure. The energy is mainly flowing from the (few) generation sites, through the electrical transport and distribution infrastructure, to the users. Legacy communication architectures for electricity grids are thus hierarchical architectures that reflect the classical structure of the power grid: measurements and data flow up from bottom (equipment and metering infrastructures) to higher levels (management centers), while control information is transmitted in the opposite direction. However, communication infrastructures have



mainly been deployed in the higher segment of electrical networks, typically involving generation plants, HV transport and HV/MV substations. Such segments have often been served through the use of ad hoc networks (mainly radio relays and in some cases fiber optic systems).

- Electric network supervision and alarms management (mainly in MV/LV substations)
  - Mono-directional (alarms + information) or bi-directional (alarms + information + activation)
  - Information transmitted
  - Communications type – Wireline, wireless or Power Line Communications
  - Bit rate, latency, others
- Remote metering
  - Power Line Communication, Wireless

### Smart grids

Future grids are expected to integrate a virtually unlimited number of sensors and meters in the distribution segments, distribution energy resources (DER) sites and homes to support demand/response, distributed generation and energy-aware applications. This will produce a huge amount of critical information for grid operation to be collected, exchanged and managed in a trustworthy way, requiring bidirectional flows among different layers. The first initiatives in such directions are the deployment of automated meter reading systems at the customers' sites, under the boost of lowering management costs and the push from government institutions. The meter provides a bidirectional communication channel:

- Control network;
- Metering network.

The Standardization Sector of the ITU (ITU-T) Study Group 15 has developed home networking Specifications under the title of ITU-T G.hnem for smart electrical grid products. G.hnem is the new project titled "Home Networking Aspects of Energy Management". The main objective of this project is to define home network devices with low complexity for home automation, home control, electric vehicles and smart electrical grid applications. Among the applications of smart electrical grid that will benefit with the G.hnem are:

- Programs on demand response based on utilities through Internet broadband communications or through AMI systems (advanced metering infrastructure);
- Remote repair to minimize costs;
- Support for systems on demand response in real time to compensate users according to their use;
- Flexible control of devices to reduce power consumption during peak periods of consumption.

The Focus Group on Smart Grid<sup>31</sup> collected and documented information and concepts that can be helpful to prepare Recommendations on the smart electrical grid from the perspective of telecommunications. Upon completion of its mandate, the Focus Group had produced five documents. The Joint Coordination Activity on smart grid and residential network (SG & JCA- HN), successor of the Focus Group, forwarded these documents to all Study Groups and Thematic Groups and urged them to use these in preparing advice. Study Group 15 of ITU-T (Transport and Access) developed a number of Recommendations on electrical transmission lines to support the smart grid.

---

<sup>31</sup> The Focus Group on Smart Grid was created in February 2010 and concluded its work in December 2011.

Study Group 5 of the ITU -T (Environment and Climate Change) is also introducing a new question on the smart grid.

There are initiatives<sup>32</sup> that target to group energetic networks as electricity and gas networks.

In the Area of Business management, the development of technologies for creating new environments of Network Operation (including simulation tools and estimation states), the Active Demand Management and the Planning and Optimization of Operations, are included.

In the area of Platform Integration and Communication, the Focus Group on Smart Grid worked on the proceedings of acquiring and processing information in real time (with the difficulties of the huge volumes of information that will be generated and the criticality of their availability), the necessary infrastructure to management and recharging of electric vehicles and requirements of supervision and control of micro-grids. These are smart networks of distribution self-managed locally, so they can function both connected to the distribution network as isolated from it.

The Network Intelligent Devices will include new techniques of signals acquisition, the development of smart devices of energetic register and automation of network equipment.

The European Commission has done intensive work on the subject; there is a working group on this issue. The Smart Grids Task Force (SGTF) was set up by the European Commission (EC) at the end of 2009. The SGTF reached a consensus over the last two years on policy and regulatory directions for the deployment of Smart Grids. The SGTF has also issued key Recommendations for standardization, consumer data privacy and security.

Based on these results, during 2011 the EC has adopted the "Communication on Smart Grids" initiative, which issued a Mandate for Smart Grids standards to the European Standardization Organization and created an Inventory of Smart Grid projects and lessons learned in the European Union<sup>33</sup>.

In order to summarize the functionalities of smart grids, this document presents an extraction from "Definition, Expected Services, Functionalities and Benefits of Smart Grids" document:

#### **A Enabling the network to integrate users with new requirements**

- 1 Facilitate connections at all voltages/locations for all existing and future devices with Smart Grid solutions through the availability of technical data and additional grid information to:
  - simplify and reduce the cost of the connection process subject to maintain network integrity/safety;
  - facilitate an 'open platform' approach – close to 'plug & play';
  - make connection options transparent;
  - facilitate connection of new load types, particularly electrical vehicle EV
  - ensure that the most efficient DER connection strategies can be pursued from a total system perspective.

---

<sup>32</sup> As the Spanish Energos Project (led by the distribution of gas and electricity Union Fenosa) is a research project for the development of knowledge and technologies to advance the deployment of smart grid power distribution (Smart-Grid). It is within the National Strategic Consortia for Technical Research (CENIT) to boost innovation and technological development in key areas of society. The Center for Industrial Technological Development (CDTI) subsidizes half the budget, amounting to 24.3 million euros.

<sup>33</sup> [http://ec.europa.eu/energy/gas\\_electricity/smartgrids/taskforce\\_en.htm](http://ec.europa.eu/energy/gas_electricity/smartgrids/taskforce_en.htm)

- 2 Better use of the grid for users at all voltages/locations, including in renewable generators.
- 3 Registers of the technical capabilities <sup>34</sup> of connected users/devices with an improved network control system, to be used for network purposes (ancillary services) to increase a better control of energy production and utilization.
- 4 Updated performance data on continuity of supply and voltage quality to inform connected users and prospective users.

#### **B Enhancing efficiency in day-to-day grid operation**

- 1 Improved automated fault identification and optimal grid reconfiguration after faults reducing outage times:
  - Using dynamic protection and automation schemes with additional information where distributed generation is present;
  - Strengthening Distribution Management Systems of distribution grids.
- 2 Enhanced monitoring and control of power flows and voltages.
- 3 Enhanced monitoring and observability of network components down to low voltage levels, potentially using the smart metering infrastructure.
- 4 Improved monitoring of network assets to enhance efficiency in day-to-day network operation and maintenance (proactive, condition based, operation history based maintenance).
- 5 Identification of technical and non-technical losses through power flow analysis, network balances calculation and smart metering information.
- 6 Frequent information on actual active/reactive injections/withdrawals by generation and flexible consumption to system operator.

#### **C Ensuring network security, system control and quality of supply**

- 1 Solutions to allow grid users and aggregators to participate in an ancillary services market to enhance network operation.
- 2 Improved operation schemes for voltage/current control taking into account ancillary services.
- 3 Solutions to allow intermittent generation sources to contribute to system security through automation and control.
- 4 System security assessment and management of remedies, including actions against terrorist attacks, cyber threats, actions during emergencies, exceptional weather events and force majeure events.

---

<sup>34</sup> Network users/devices, to actively participate/be managed in network's operations and energy management must be characterized by adequate technical capabilities. Considering the active control and demand-response of Distributed Energy Resources (i.e. generators, controllable loads and storage) some of the most relevant technical capabilities that have to be taken into account are: (i) Active – reactive power capabilities (ii) Dynamic response, (iii) Electric storage capacity in terms of energy and power. For example, referring to the renewable generators participation in the network voltage regulation or power flows control, the generator reactive power capability curve and the other capabilities aforementioned, are technical constraints that have to be managed.

- 5 Improved monitoring of safety particularly in public areas during network operations<sup>35</sup>.
- 6 Solutions for demand response for system security purposes in required response times.

#### **D Better planning of future network investment**

- 1 Better models of DG, storage, flexible loads (including EV), and the ancillary services provided by them for an improvement of infrastructure planning.
- 2 Improved asset management and replacement strategies by information on actual/forecasted network utilization.
- 3 Additional information on supply quality and consumption made available by smart metering infrastructure to support network investment planning.

#### **E Improving market functioning and customer service**

- 1 Solutions for participation of all connected generators in the electricity market.
- 2 Solutions for participation of VPPs in the electricity market, including access to the register of technical capabilities of connected users/devices.
- 3 Solutions for consumer participation in the electricity market, allowing market participants to offer:
  - Time based energy pricing, dynamic energy pricing and critical peak pricing;
  - Demand response / load control programs.
- 4 Grid solutions for EV recharging:
  - Open platform grid infrastructure for EV recharge purposes accessible to all market players and customers;
  - Smart control of the recharging process through load management functionalities of EV.
- 5 Improved industry systems for settlement, system balance, scheduling and forecasting and customer switching.
- 6 Grid support to intelligent home/facilities automation and smart devices by consumers.
- 7 Individual advance notice to grids users for planned interruptions.
- 8 Customer level reporting in event of interruptions (during, and after event).

#### **3.1.2 Smart water management**

Smart Water Management (SWM) promotes the sustainable consumption of water resources through coordinated water management, by the integration of ICTs products, solution and systems, to maximize the socioeconomic welfare of a society without compromising the environment. As it was indicated before, SMW has applicability in many different sectors (for example industries, agriculture etc.).

---

<sup>35</sup> Control of access to the equipment, detection of fault on overhead networks, protection of the contents of the buildings.

From a general point of view, SMW has two main functions:

- Sensing: This involves the use of Internet of Things (IoT) technology for sensing and intelligent monitoring to achieve business related data and centralized management such as water quality monitoring, ship scheduling in rivers, etc.;
- Intelligent scheduling: Water resource could be sensed by the IoT integrated system to make decisions on flood control and drought prevention; intelligent management of water environment; and intelligent management of water distributions.

Steps have been made to improve the capabilities of the information technology needed for flood and drought decision, water environment treatment, and water resources management.

In particular, smart metering technologies will play an important role in the real-time measurement of water consumption, identifying leaks at the consumer level and raising more awareness to consumers on water consumption. With the development of sensors of active outlet, the web of semantic sensors, the geoweb, the geographic modelling in 3D, and mobile communications, this field has great potential for water authorities.

### Smart Water Management in Cities<sup>36</sup>

In today's integrated global economy and innovations in telecommunications, have created a massive opportunity in utilities to assist in addressing management water challenges within cities and urban water management.

The recognition of the challenges in the water sector have created intelligent tools which use ICTs to alleviate global water issues. These technologies create tremendous opportunities to improve the productivity and efficiency within the water sector with an aim to generate sustainability of the resource. ICTs permit the continuous monitoring of water resources, providing real time monitoring and measuring, making improvements in modelling and by extension problems diagnosis, enabling proper maintenance and optimization all aspects of the water network.

An opportunity for more intelligent means to manage and protect the planet's water resources has led to the development of Smart Water Management (SMW).

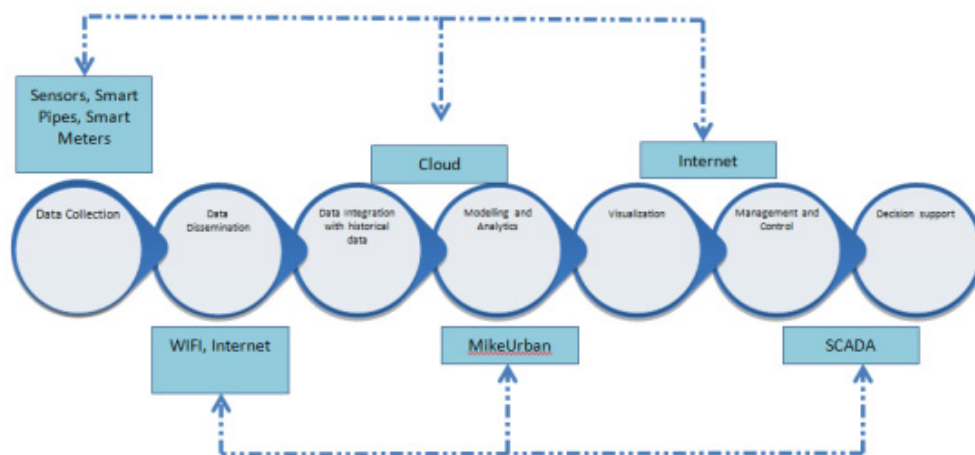
Smart Water Management increases the efficiency of the water sector while ensuring its economic sustainability since municipalities and water utilities are better able to recover costs from non-revenue water and are better able to detect illegal connections.

Smart Water Management tools fall into the main areas listed below. However it should be noted that the examples provided are not confined only to the areas represented but may overlap several areas as seen in Figure 48.

- 1 Data acquisition & integration; (e.g., sensor networks, smart pipes, smart meters etc.);
- 2 Data dissemination; (e.g., Radio transmitters, WIFI, Internet etc.);
- 3 Modelling and analytics; (e.g., GIS, MikeURBAN, Aquacycle, AISUWRS, and UGROW etc.);
- 4 Data processing and Storage; (e.g., SaaS, Cloud computing, etc.);
- 5 Management and Control; (e.g., SCADA, optimization tools, etc.);
- 6 Visualization and decision support; (e.g., Web-based communication and Information systems tools etc.).

---

<sup>36</sup> Extracted from the document SSC-0122-rev3 "Technical Report on Smart Water Management for Smart Sustainable Cities"

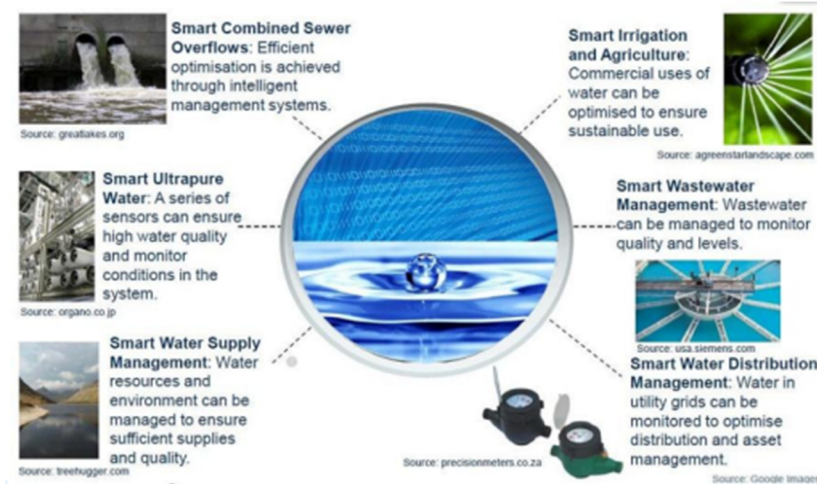


**Figure 51 – Schematic Representation of Smart Water Management Technologies and Tools**

Source: McIntosh 2014

**Smart Water Management Technologies**

Smart Water Management technologies are already currently applied to many different areas of water management (Figure 49). These technologies when applied to cities, help acquire reliable data and enhancement to operations and safeguard proper decision making. In this context, many of these innovative ICT tools have been developed to shape next-generation urban water infrastructure systems to improve performance, increase efficiency, reduce costs, decrease redundancy, as well as ensure negligible environmental impacts.



**Figure 52 – Current Implementation of Smart Water Management Technologies and Tools**

Source: Hauser 2012

**Smart Pipes and Sensor Networks<sup>37</sup>**

Smart Pipes incorporates multi-functional sensors that can sense strain, temperature and pressure anomalies, as well as measure water flow and quality during service, to provide operators with

<sup>37</sup> For more information: <http://www.isws.illinois.edu/gws/sensor/smartpipe/>



continuous monitoring and inspection features assuring safer water supply distribution. Connecting Smart Pipes with a wireless processor and antenna enables data to be transferred directly to a command center, equipping water managers with the tools to detect and locate potential leaks in real time.

Sensors can also be incorporated to optimize the water used in irrigation to measure parameters such as: air temperature, air humidity, soil temperature, soil moisture, leaf wetness, atmospheric pressure, solar radiation, trunk/stem/fruit diameter, wind speed/direction, and rainfall. The range of application within cities can be from park irrigation or commercial irrigation, allowing for better management and more accurate allocation of water resources between sectors.

Wireless Sensor Networks provide the technology for cities to more accurately monitor their water supply systems intricately using different parameters. Sensors are multifunctional for instance they have the ability to monitor soil moisture and can therefore detect leaks since if the ground is absorbing water there may be a pipe leak. Many ICT companies are developing a wide range of sensors specifically for water networks.

The major tasks for smart sensor networks in water quality monitoring are to:

- Identify and characterize changes existing or emerging trends in surface water quality over time;
- Gather information to design or assess specific pollution prevention or remediation programs or to provide information in a timely manner to allow quick respond to emergencies, such as spills and sewage leakages;
- Determine whether program goals – such as compliance with pollution regulations or implementation of effective pollution control actions – are being met.

Integrating Smart Pipes and sensors within the urban system, leads to many possibilities such as the detection of flow rate, pipe pressure, stagnant points, slow-flow sections, pipe leakage, backflow, and water quality; necessary data lacking in current networks.

### Smart Metering

Smart meters are electronic devices which have advanced metering infrastructure (AMI) that would support the real time measuring of electric, heat, gas, and water consumption. These devices are rapidly evolving in response to market forces and governmental regulations. In the case of water consumption, these smart meters typically consist of an embedded controller which interfaces with a metering sensor, a wireless transmitter as well as display and communications extension. The meters are connected to a data logger which allows for the continuous monitoring of water consumption of a building, a business or a home. The innovation of smart meters, permit two-way communication between the meter and a central system by transmitting data which can be done through different channels (power line, Internet, or telephone).

Smart meters typically collect consumption data, transmitting this data to a Gateway which interfaces with the Local Area Network (LAN), Home Area Network (HAN) and a Wide Area Network (WAN). The LAN consists of the metrology or measurement function of the meter, while the HAN is connected to the customers' network. Moreover, due to the display functions of the HAN easily allows accessibility to consumption data through a user friendly interface with possibilities for customers to compare and track their water consumption. The WAN is managed by the utilities and allows them to track, monitor and bill consumption.

The deployment of smart meters within an urban infrastructure enables remote accessibility of consumption data which improves meter reading and billing, detection of leaks, illegal connections and tamper alerts, as well as enhances the determination of peak demand. Customer and provider relationships are improved through increased communication and consumers are also equipped to options to change payment methods (e.g., Prepaid or Post-paid).

Moreover smart metering allows the water utilities to provide clear, water consumption information which can help customers to track and control their water usage and thereby see immediate savings on their bills thereby enabling better distribution network and consumption planning due to the real-time monitoring capabilities.



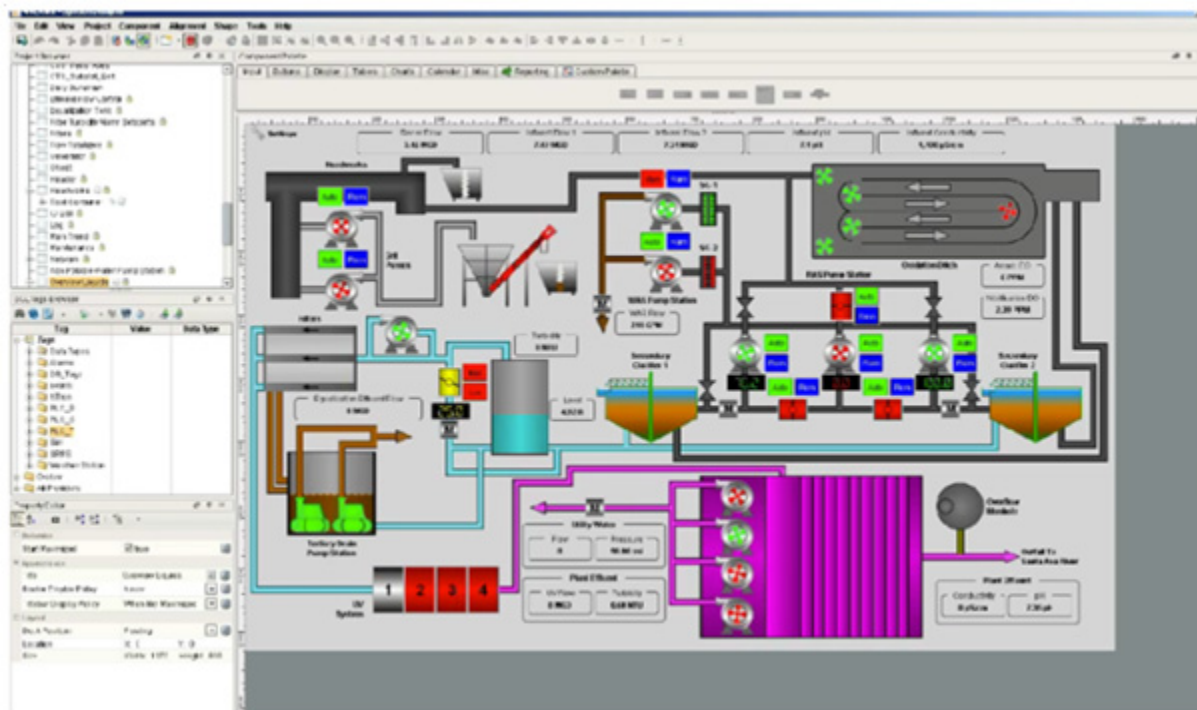
**Figure 53 – Smart meter technologies**

Source: <http://www.allianceforwaterefficiency.org/smart-meter-introduction.aspx>

GIS integration can improve data management especially of large volume projects. GIS provides high quality result display especially in hydraulic simulation modelling and provides additional analysis useful for decision support. GIS allows visualization and analysis of data about water resources/issues and human activity by linking geographic information with descriptive information. This is highly valuable to the urban water management in assessing water quality and day to day operations on a local and regional scale. However, its benefits are not limited to that as urban issues such flooding can also be mitigated by the use of GIS by providing information on critical areas which are at a risk of flooding. This is necessary in developing hazard maps as well as development of emergency response planning. GIS utilization offers more robust analysis, increased efficiency and reduced costs.

By integrating information from resource satellites, GIS can cover large river basins which some cities occupy. Combined with local rainfall patterns, meteorological and hydrological data, as well as drainage systems, GIS improve urban storm water management by strengthening drainage management and enhance rainwater reuse. This helps to reduce the prevalence of urban flooding which is increasing in cities since the development of infrastructure in cities has created large expanses of impermeable earth.

Supervisory Control And Data Management (SCADA) systems when incorporated in water management systems are computer-controlled systems which contain large communication systems that permit the monitoring and control water treatment and distribution as well as wastewater collection and treatment. The system allows for supervision through data acquisition and management with the ability to process and send commands within the system. The communication system may involve radio, direct wired connections or telemetry. Its dynamic network can allow for weather forecast model inputs as well as hydraulic model system optimization.



**Figure 54 – SCADA software the Western Municipal Water District (WMWD), California**

Source: [http://www.automationworld.com/sites/default/files/styles/lightbox/public/field/image/120723scada\\_web.png?itok=IXV7wPd](http://www.automationworld.com/sites/default/files/styles/lightbox/public/field/image/120723scada_web.png?itok=IXV7wPd)

Utilities have been using SCADA systems for higher-level applications; such as determining times of peak water use, identifying potential system leaks, setting billing rates etc. SCADA systems have even reduced the operating costs of utilities and have improved the delivery water distribution to the residential and businesses and industry. The monitoring aspect of SCADA systems also helps utilities to protect their infrastructure and prevent severe degradation. In 2013, implementation of SCADA has seen 30% savings on energy used to manage water systems, 20% reduction on water loss and 20% reduction in disruption. Applying SCADA in an urban system also can see the enhancement of disaster preparedness through storm water management or support the remote operation and monitoring of major dams and weirs.

### Models, optimization tools and decision support

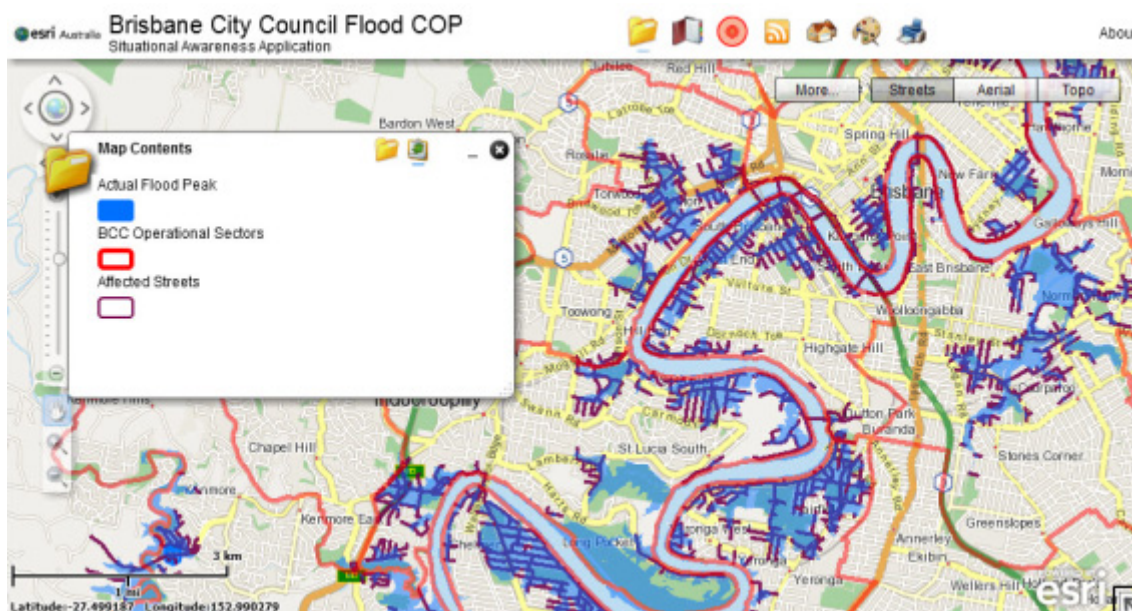
Model based water management has evolved over the years to improve the quality and quantity of global water supply through comprehensive modelling applications. These modelling software incorporate to some extent processes observed in the real world (through equations, algorithms and scenarios) and contain various data reporting and visualization tools useful for interpreting results from water distribution piping systems, water quality monitoring data, wastewater management systems etc. for decision support. Urban water managers have used many models such as MikeURBAN, Aquacycle, AISUWRS, and UGROW etc.

Optimization tools aim to finding the technical, environmental and financial best solution from models, therefore "optimization tools and principles have made it possible to develop prescriptive models for optimal management of large scale water resources systems, incorporating ubiquitous uncertainties in the prediction of natural processes and the economic impacts" (Datta and Harikrishna). By incorporating optimization tools, decision making in the planning, design and operation water resources systems can be achieved in an efficient and effective manner.

Models, optimization tools and decision support for network management urban water and wastewater are able to calculate and forecast consumption, reduce costs through the optimization of operations, plan and evaluate strategies and conduct vulnerability studies.

### Web-based Communication and Information System tools

Information and knowledge management are increasingly recognized as important features in effective and efficient work in the water sector (Dondeynaz et al. 2009). The main problem is that more data within in the water sector are large, complex, unstructured and fragmented. However Web-based interfaces and online platforms provides a solution for proper management, display, and retrieval of relevant information necessary for water managers/operators, urban planners, governments and the public alike.



**Figure 55 – The Brisbane City Web based Flood Map**

Source: [http://www.sweetmaps.com/blog/wp-content/uploads/2011/01/BCC\\_esri\\_flood\\_map.jpg](http://www.sweetmaps.com/blog/wp-content/uploads/2011/01/BCC_esri_flood_map.jpg)

Web-based servers offer access to integrated information from heterogeneous data sources, as well as the innovative tools for analysis and assessment of a broad area such as climate change, water scarcity, human health, sanitation and urbanization necessary for proper urban water management. Integration of such web based communication tools using open communication standards allow a range of stakeholders to connect to the system, to use or add to its resources.

Information and Communication systems which are composed of two parts can enable both the general public and administrators to access relevant information; allowing for transparency and visibility of current water related activities by the specialized users (such as water managers, municipalities, governments), building trust and better public/stakeholder involvement. An intuitive and user friendly interface, means that there can be ease of data acquisition and dissemination especially for the public.



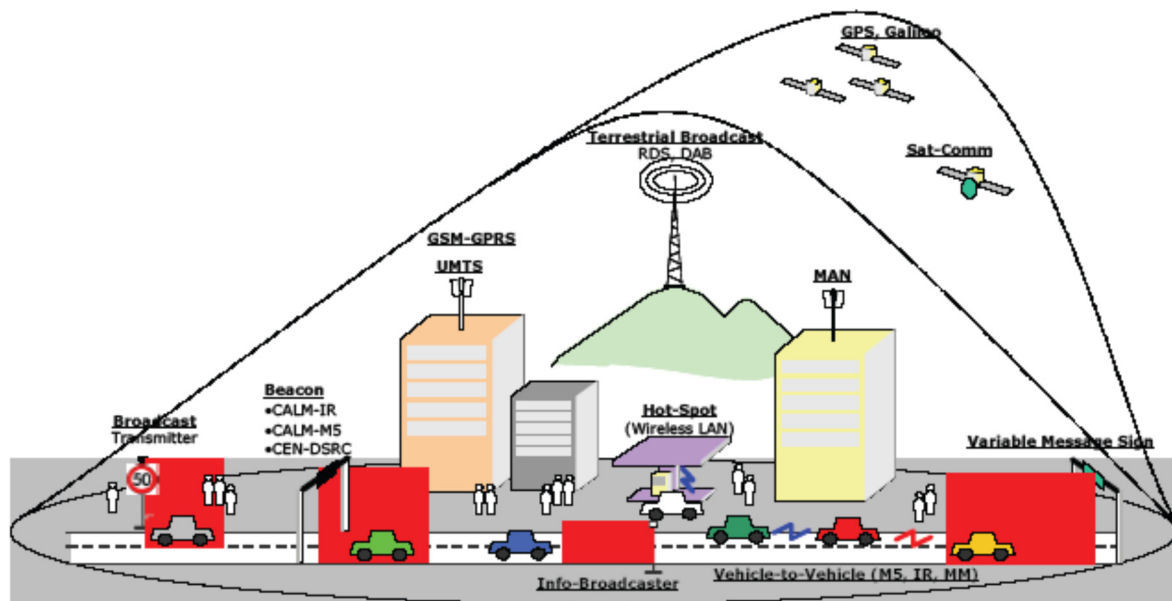
Web-based Information and Communication System tools for information acquisition have been successfully utilized by governments and municipalities to deliver high quality water information to the public as well as provide flood warnings. Such systems can allow urban water managers access to relevant information such as rainfall, storage, distribution while providing necessary information to the public.

### 3.2 Transportation

Intelligent Transport Systems (ITS) may be defined as systems utilizing a combination of computers, communications, positioning and automation technologies to use available data to improve the safety, management and efficiency of terrestrial transport, and to reduce environmental impact<sup>38</sup>.

ITS incorporate four essential components, as illustrated in the following figure:

- Vehicles, which can be located, identified, assessed and controlled using ITS;
- Road users, who employ ITS, for instance, for navigation, travel information and their monitoring capabilities;
- Infrastructure, for which ITS can provide monitoring, detection, response, control, road management and administration functions;
- Communications networks, to enable wireless transactions amongst vehicles and transport users.



**Figure 56 – Intelligent Transport Systems (ITS)**

Source: The CALM Forum/ISO TC 204, reprinted in ITU-R Land Mobile Handbook, Vol 4: Intelligent Transport Systems (2006), available at: [www.itu.int/pub/R-HDB-49-2006/en](http://www.itu.int/pub/R-HDB-49-2006/en)

<sup>38</sup> "Intelligent Transport Systems and CALM" ITU-T Technology Watch Report 1 October 2007. [https://www.itu.int/dms\\_pub/itu-t/oth/23/01/T23010000010003PDFE.pdf](https://www.itu.int/dms_pub/itu-t/oth/23/01/T23010000010003PDFE.pdf)

Intelligent Transport Systems (ITS) include telematics and all types of communications in vehicles, between vehicles (e.g., car-to-car), and between vehicles and fixed locations (e.g., car-to-infrastructure). However, ITS are not restricted to Road Transport - they also include the use of ICT for rail, water and air transport, including navigation systems<sup>39</sup>.

There are currently the following projects related to automotive ITS:

A Continuous Air interface Long and Medium range (CALM) provides continuous communications between a vehicle and the roadside using a variety of communication media, including cellular, 5 GHz, 60 GHz and infra-red links. CALM will provide a range of applications, including vehicle safety and information, as well as entertainment for driver and passengers.

The aim of CALM is to provide wide area communications to support ITS applications that work equally well on a variety of different network platforms, including Second Generation (2G) mobile (e.g., GSM/GPRS), 3G (IMT-2000 e.g., W-CDMA/CDMA 1x EV-DO) 4G (IMT-Advanced), as well as satellite, microwave, millimeter wave, infrared, WiMAX and short-range technologies like Wi-Fi.

The main characteristics of CALM are:

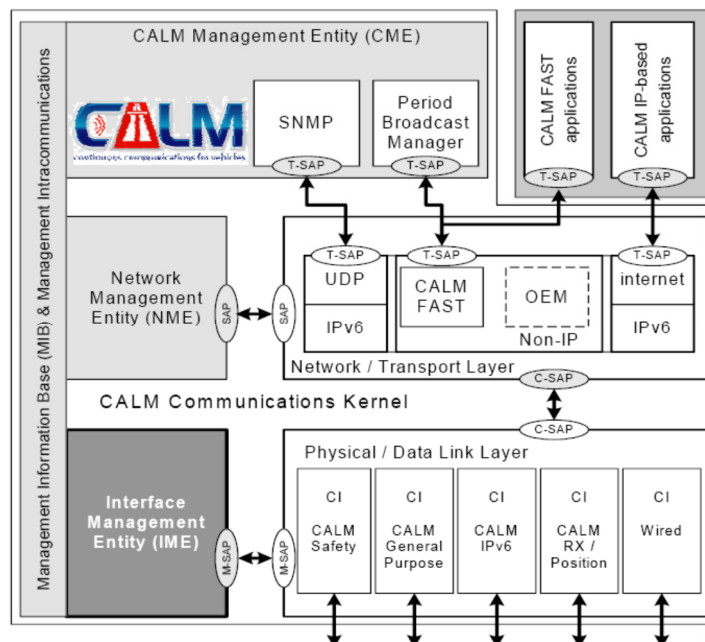
- Allows for continuous (or quasi-continuous) communications, in three main modes of operation: Vehicle-Infrastructure; Vehicle-Vehicle; and Infrastructure-Infrastructure.
- Inter-operability and seamless handover between networks and applications.
- In its initial specification, CALM used Internet Protocol version 6 (IPv6) exclusively. However, in order to meet the requirement for very fast short communications in time and in critical situations, such as C2C applications (e.g., collision avoidance), a non-IP solution with lower processing overhead and lower latency may be more suitable, and this is incorporated in the new specification (CALM Fast).
- It is the single global architecture which is compatible with existing ITS standards (e.g., DSRC) and wireless standards (e.g., GSM/GPRS) and which is expected to conform to future ones too.
- It provides platform-independent support for multiple radio communication network platforms. For instance, the basic CALM system architecture (ISO 27217) foresees support for 10 main categories of network, and 22 different sub-categories each of which would need a different Service Access Protocol (SAP).

The next figure shows the new (2007) merged CALM architecture. The likely future direction seems to be a flexible CALM architecture and a division of labour among different organizations.

---

<sup>39</sup> European Telecommunications Standards Institute  
<http://www.etsi.org/technologies-clusters/technologies/intelligent-transport>





**Figure 57 – CALM architecture**

Source: ISO TC 204 –See: [http://www.itu.int/dms\\_pub/itu-t/oth/06/05/T06050000130001PDFE.pdf](http://www.itu.int/dms_pub/itu-t/oth/06/05/T06050000130001PDFE.pdf)

CALM is intended to provide a standardized set of air interface protocols for ITS applications, using multiple network platforms. These include:

- 2G mobile systems, including GSM/GPRS, which are the most widely deployed mobile network worldwide;
- 3G (IMT-2000) mobile systems, including W-CDMA and CDMA 1x EVDO;
- Infrared;
- Wireless LAN systems, including the IEEE 802.11 series;
- Millimeter wave systems, including radar;
- DSRC, including national and regional implementations;
- Wireless MAN systems, including WiMAX;
- Broadcast signals, including GPS and Digital Audio Broadcasting (DAB);
- Personal Area Networks (PAN) including UWB and Bluetooth;
- Fixed-line networks (for infrastructure to infrastructure communications), including Fiber and Ethernet.

The next figures show some scenarios of application for vehicle safety and information.

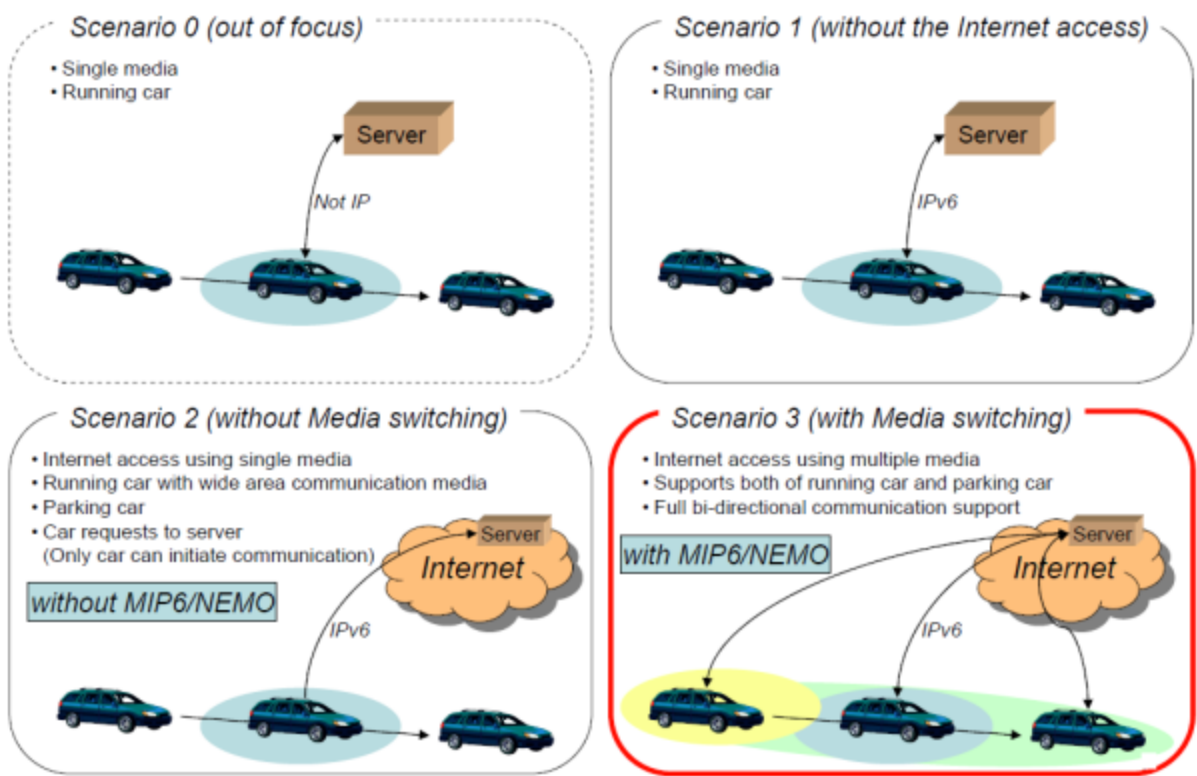


Figure 58 – CALM architecture

Scenario 3 shows the three physical configurations: Internet access using multiple media with full bi-directional communication support.

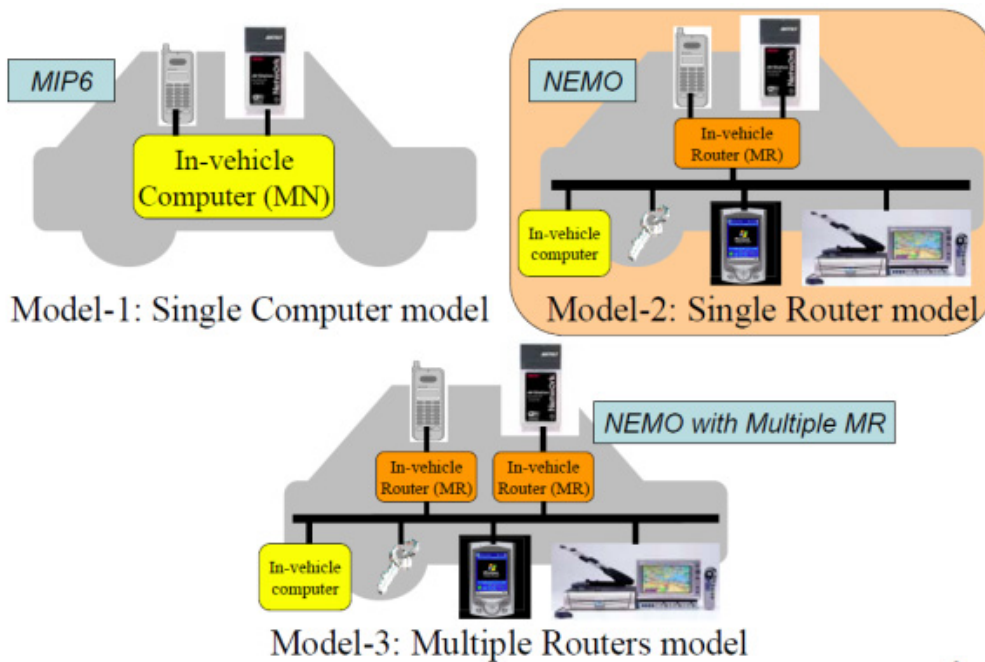


Figure 59 – Three Physical configuration in Scenario 3

The next figure shows the summary description of the entities defined in the CALM architecture and Service Access Protocol (SAP).

- CME: CALM Management Entity  
Match making application policy and Network status
  - NEM: Network Management Entity  
- Signal to CME the Network status  
- Control MIP6/NEMO status
  - IME: Interface Management Entity  
- Signal to NME the media status
  - 2G: 2<sup>nd</sup> Generation Cellular Phone
  - 3G: 3<sup>rd</sup> Generation Cellular Phone
  - IR: Infrared
  - M5: 5GHz Band ITS Media
  - MM: Microwave Media
  - PPM: Point to Point Millimeter wave
  - WBB: Wireless Broadband
  - IVN: In-Vehicle Network
- SAP defined in ISO21210  
■ SAP defined outside of ISO21210

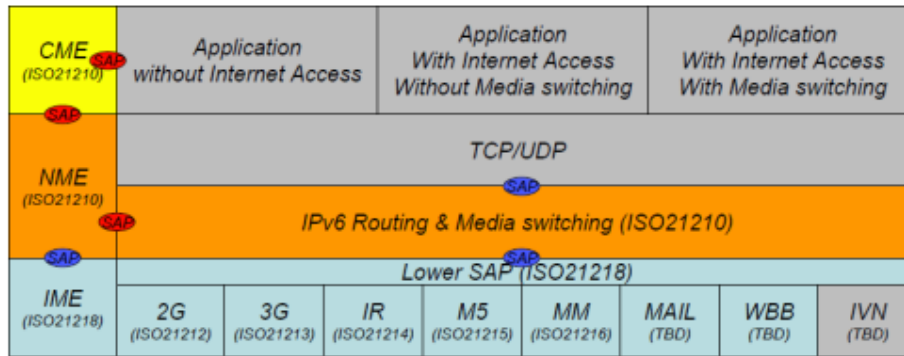


Figure 60 – CALM Architecture and SAPs of Networks Part

B Dedicated Short-Range Communications (DSRC) provides communications between the vehicle and the roadside in specific locations (for example toll plazas). Applications such as Electronic Fee Collection (EFC) will operate over DSRC. The following figure shows the interaction of DSRC and CALM.

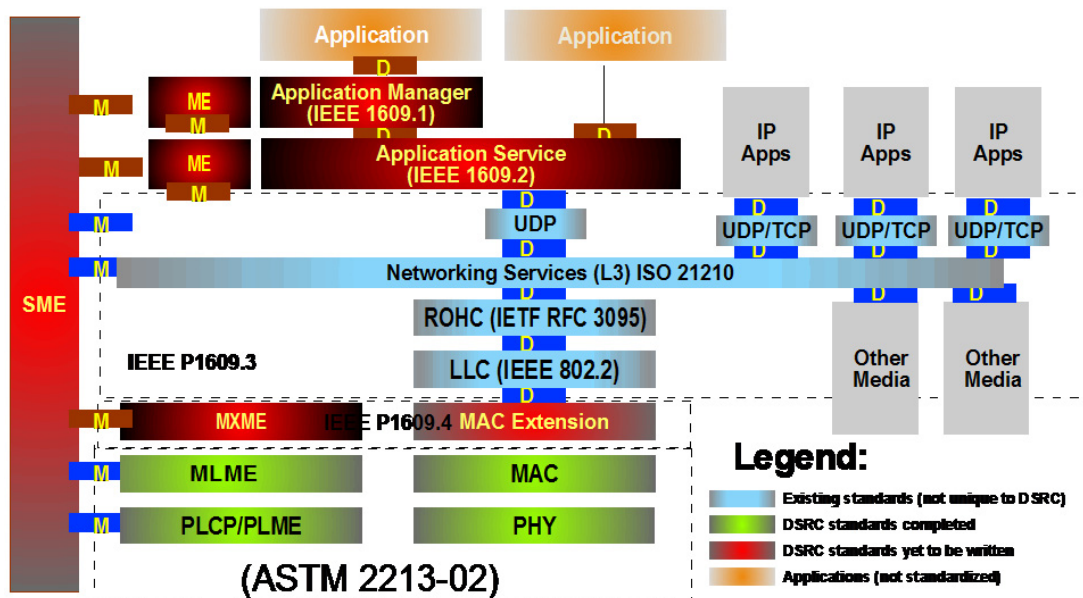


Figure 61 – ISO TC204 WG16 CALM M5 Architecture

C Wireless multiservice payment system for vehicles:

Toll payment collection on highways is one of the applications of Intelligent Transport System (ITS) Technology. At the beginning of the 1990s, the Electronic Fee Collection (EFC) tele-toll systems were introduced in Europe by various highway operators. These systems are currently generalized all over

Europe. The advantage of electronic payment is the fact that the vehicle does not need to stop, thus avoiding traffic jams, besides the fact that it is not necessary to carry money. In this way, it is possible to provide greater customer satisfaction and a reduction of human resource costs to the operator, among other advantages.

Typically, a tele-toll system is based on short range microwave technology designed for the purpose, known as Dedicated Short Range Communications (DSRC). However, for the majority of European highway concession holders the systems are incompatible with each other, given that the initial standard only served as a Recommendation for the system. Hence each operator installs it in accordance with the application sought. The majority of these systems are based on the Low Data Rate (LDR) sub-standard, given that this was the first standard created. The incompatibility raises some difficulties for car drivers, who (sometimes inside the same area), have to affix several identifiers in their vehicle if they wish to use various systems. With the increase in traffic on European roads, the problem of interoperability between country systems/operators takes on greater importance. With a view to resolving this problem, the Medium Data Rate (MDR) sub-standard was devised, aiming at providing interoperability between countries and systems. Nowadays, DSRC technology is not used exclusively for the electronic payment of tolls, for it is starting to have other applications, such as payment at parking lots and fuel stations, or even simply for controlling the access of vehicles. This system implies the need for toll barriers (access points), where the vehicle makes the transactions.

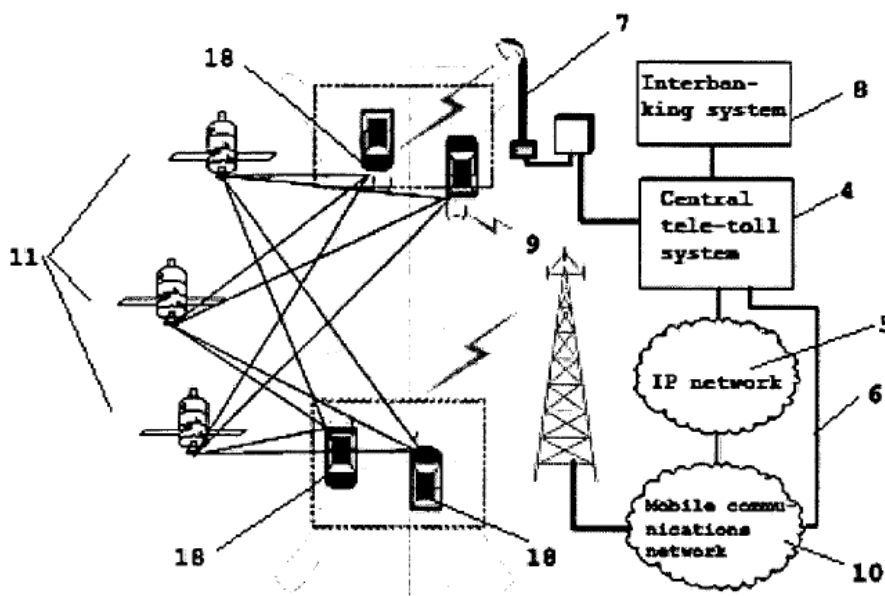


FIG. 1

Figure 62 – Diagram of the operation of the toll payment systems on highways

Source: European Patent Application EP 1944736 A1

Communication through short range radio based on microwaves (9) is regulated by the DSRC standard, which is currently used in tele-toll systems (4). There are three sub-standards in the DSRC, which are LDR, MDR and HDR (High Data Rate). LDR merely contains recommendations, having no obligatory character. On the other hand, MDR, was developed in order to guarantee greater interoperability between systems. HDR was devised to permit communication between vehicles. The MDR sub-standard is the one adopted in this invention, consisting of three layers which have a message/protocol stack specific for carrying out transactions.

The DSRC system mainly consists, in terms of radio, of two units: the Road Side Unit (RSU) and the On Board Unit (OBU). The RSU is placed at the tollgate, being responsible for starting and ending the communication with the OBU, in order to carry out the transaction. Of the two units, it can be said that the RSU is fully active, since it is always connected and is the only one which transmits a carrier, so as to provide communication. This carrier is also used by the OBU so as to enable it to communicate, by reflection, with the RSU. The OBU is the equipment placed inside the vehicle in order to permit its identification. This module only has to generate a sub-carrier, which modulates the carrier received from the RSU, reflecting it back to the RSU. The OBU is passive, given that it does not generate a carrier to communicate with the RSU. Furthermore, the OBU is only active when it detects the RSU carrier, its consumption thus being minimised.

The use of the MDR standard makes it possible for the communication between the OBU and the RSU to be established through microwaves or infrareds. The following figure shows a schematic representation of the module installed on board the motor vehicle and its links to the various technologies available for operating the system.

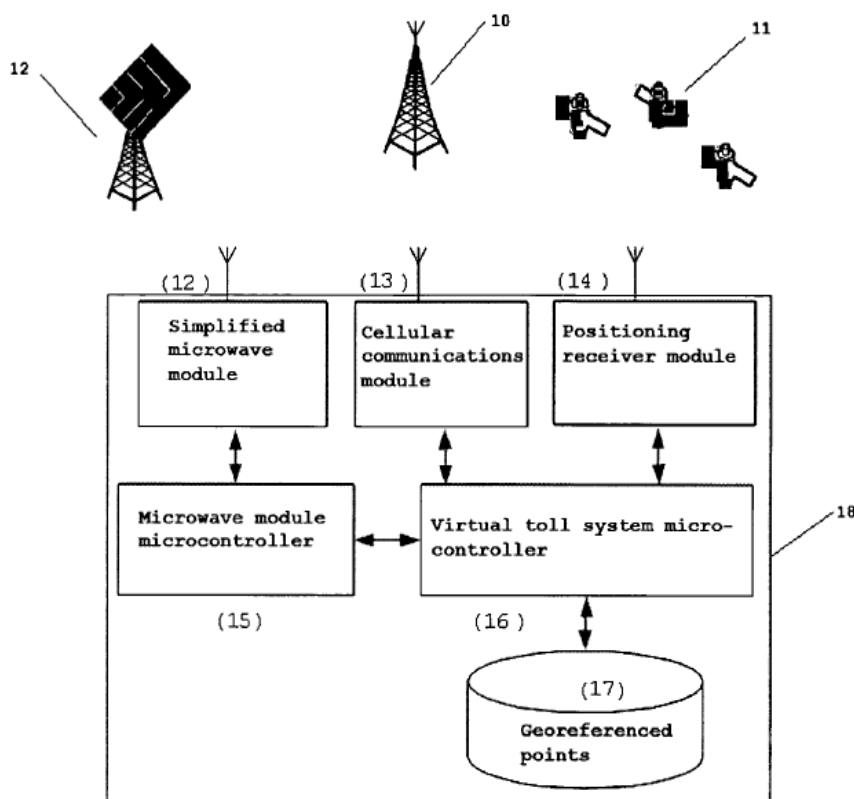


FIG. 2

Figure 63 – OBU and different technologies

Source: European Patent Application EP 1944736 A1

These technological projects form a part of wider initiatives on matters such as road safety (for example the European Commission's eSafety initiative) and road tolling.

The goal of intelligent transportation systems (ITS) is to improve the effectiveness, efficiency, and safety of the transportation system. Effective deployment of ITS technologies depends in part on the knowledge of which technologies will most effectively address the issues of congestion and



safety. Thus, it is important to understand the benefits of both existing and emerging technologies. Based on documented experience locally and throughout the country, ITS deployments in urban areas have the potential to offer the following benefits<sup>40</sup>:

- Arterial management systems can potentially reduce delays between 5% and 40% with the implementation of advanced control systems and traveler information dissemination.
- Freeway management systems can reduce the occurrence of crashes by up to 40%, increase capacity, and decrease overall travel times by up to 60%.
- Freight management systems reduce costs to motor carriers by 35% with the implementation of the commercial vehicle information systems and networks.
- Transit management systems may reduce travel times by up to 50% and increased reliability by 35% with automatic vehicle location and transit signal priority implementation.
- Incident management systems potentially reduce incident duration by 40% and offer numerous other benefits, such as increased public support for DOT activities and goodwill.

Besides ITU and ETSI (European Telecommunications Standards Institute), there are works from other institutions, thus IEEE has an organization named "IEEE Intelligent Transportation Systems Society". In the same way a helpful resource was the National ITS Benefits Database available at [www.benefitcost.its.dot.gov](http://www.benefitcost.its.dot.gov).

### 3.3 Healthcare

Healthcare delivery can benefit from a connected approach, with Electronic Patient Records (EPR) available to all medical services. This will enable public health professionals and clinicians to collaboratively access information in a secure way, at any time, from anywhere and from any device.

In many cases, telemedicine solutions, connected through broadband, wireless or satellite, can prove vital in situations where the infrastructure or specific contingencies do not allow for the physical presence of a specialist – such as natural disasters or remote geographical locations.

An ageing population needs traditional care, but also assisted living and health monitoring services to enable independence at home. This can be achieved through the utilization of sensors and devices connected to health operators through broadband, wireless and data analytics, and crucially, the deployment of privacy, identification and security systems.

The new telemedicine services, such as online medical consultations, improved emergency care and portable devices that allow monitoring the health status of people with chronic diseases and disabilities, can provide a freedom of movement which was previously unknown.

#### 3.3.1 M2M use cases: e-health<sup>41</sup>

Figure 59 shows overview of e-health M2M use cases written in this deliverable. There are various kinds of sensors near patients and their sensors send data to M2M Platform. In e-health use cases, caregiver provides care services supported by medical institutions using vital data and related information on M2M Platform.

---

<sup>40</sup> "Benefits of Intelligent Transportation Systems Technologies in Urban Areas: A Literature Review" Portland State University [http://www.its.pdx.edu/upload\\_docs/1248894206QpPC5zVqkd.pdf](http://www.its.pdx.edu/upload_docs/1248894206QpPC5zVqkd.pdf)

<sup>41</sup> Focus Group on Machine-To-Machine Service Layer M2M-I-196



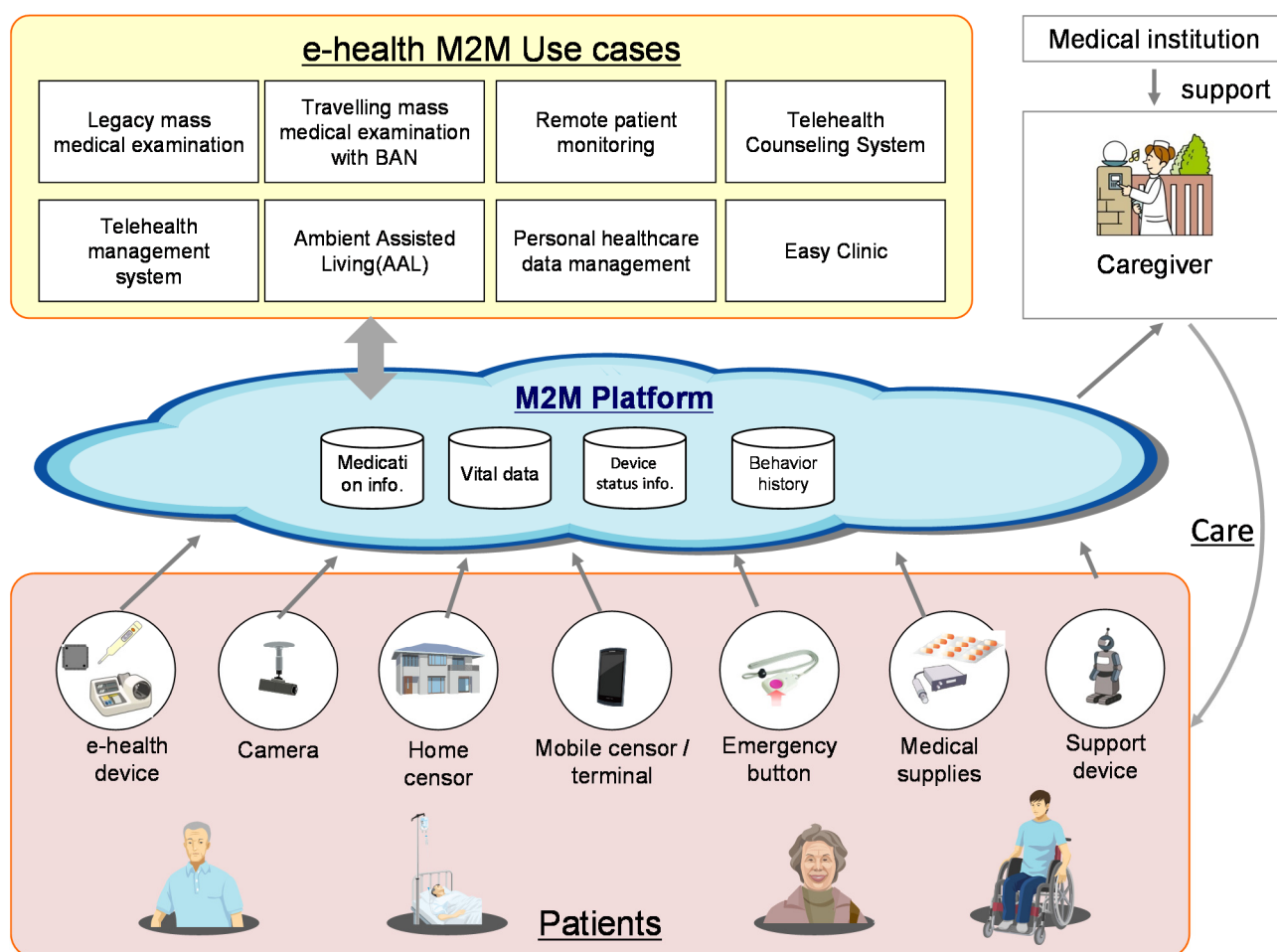


Figure 64 – Overview of e-health M2M use cases.

### 3.4 Public safety and emergency

The power provided by the ICT infrastructure to public safety is beyond doubt. However a city highly dependent on all aspects of technology, has risks of sabotage that can disable much of their public services and good performance in general, so public safety must also ensure the continuity of the technological features using a good protection to the ICT infrastructure.

Public Safety is one of the key issues of a city. ICT facilities should include:

- City safety system combined with environmental monitoring, road monitoring, perimeter security, product safety and access control, and other functions;
- Cloud-based large-scale data storage, retrieval, intelligent video analysis, biometric technology, integrated platform for data intelligent analysis, etc.;
- Increased bandwidth to support a wide range of applications of security. The smart city safety system builds a network of security, helping security officers avoid misjudgments, while providing a scientific and reliable method for security.

Two important systems for public safety: Geo-location Systems of Cell Phones and the System of National Alert using cell broadcast are shown in Figure 60. Both systems are interconnected and managed by the Centralized Emergency Center.

It's important to note that these types of solutions, requires not only ICT infrastructure, smart network and sensors (e.g., surveillance cameras) but also the participation of public/private organizations involved in emergency tasks, such as firemen, police, health professionals, etc. with established procedures to attend emergencies.

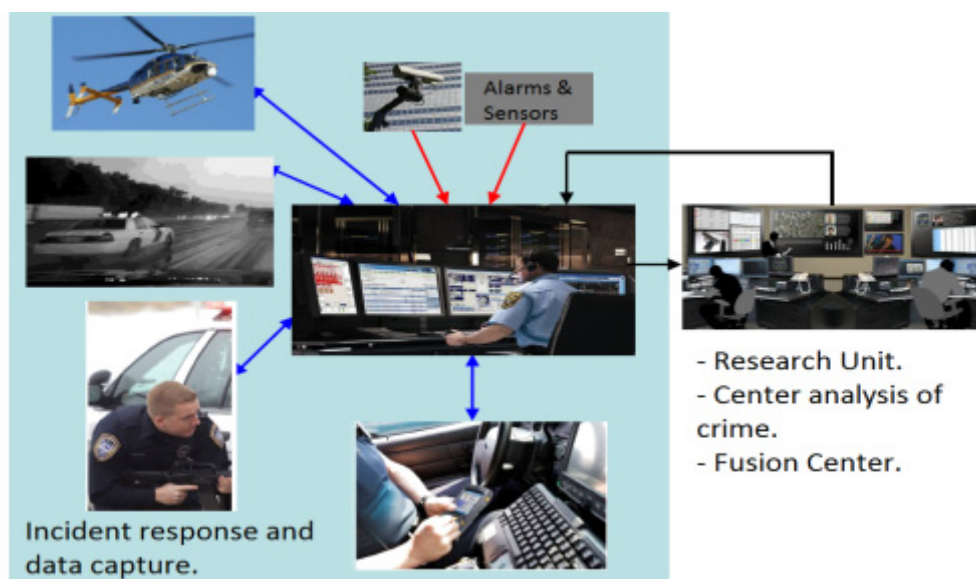
### Centralized Emergency Center

Quickly reaching the right place where an accident, fire or a crime has occurred or is occurring, is vital to save lives and minimize damage. Therefore the emergency centers need to obtain the exact location where the event is occurring and other key information quickly in order to facilitate swift responses.

One of the main objectives of an emergency center is to reduce the response time to a minimum, as a minute lost to reach the exact location of the emergency can cost lives.

A caller location system needs an emergency center that receives and centralizes all calls. This brings the following benefits:

- a Increases personal safety of citizens and reduces crime;
- b Allows better coordination of emergency response tasks;
- c Brings speed and efficiency to the work of police, fire and ambulance;
- d Significantly reduces the incidence of false calls.



**Figure 65 – Flow Information of public Safety**

Components that will be installed in the Emergency Care Centers are following:

- Core Switching with technology "Voice over IP" (VoIP) with Automatic Call Distribution;
- Computer Aided Dispatch;
- GIS Server;
- Calls Recording Equipment;
- Data Base for location of fixed phones.

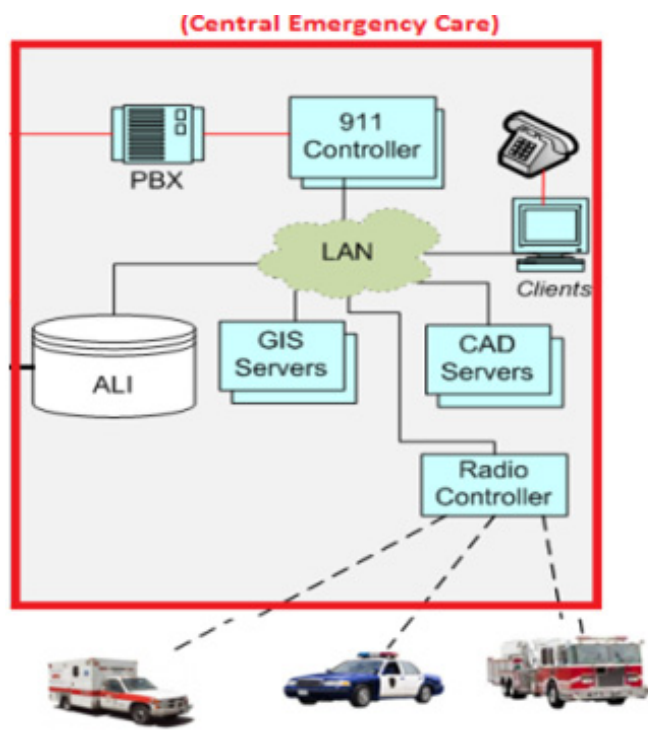


Figure 66 – Emergency Network

Location of Emergency Calls

The solution needs a Location Platform, as is shown in the following figure:

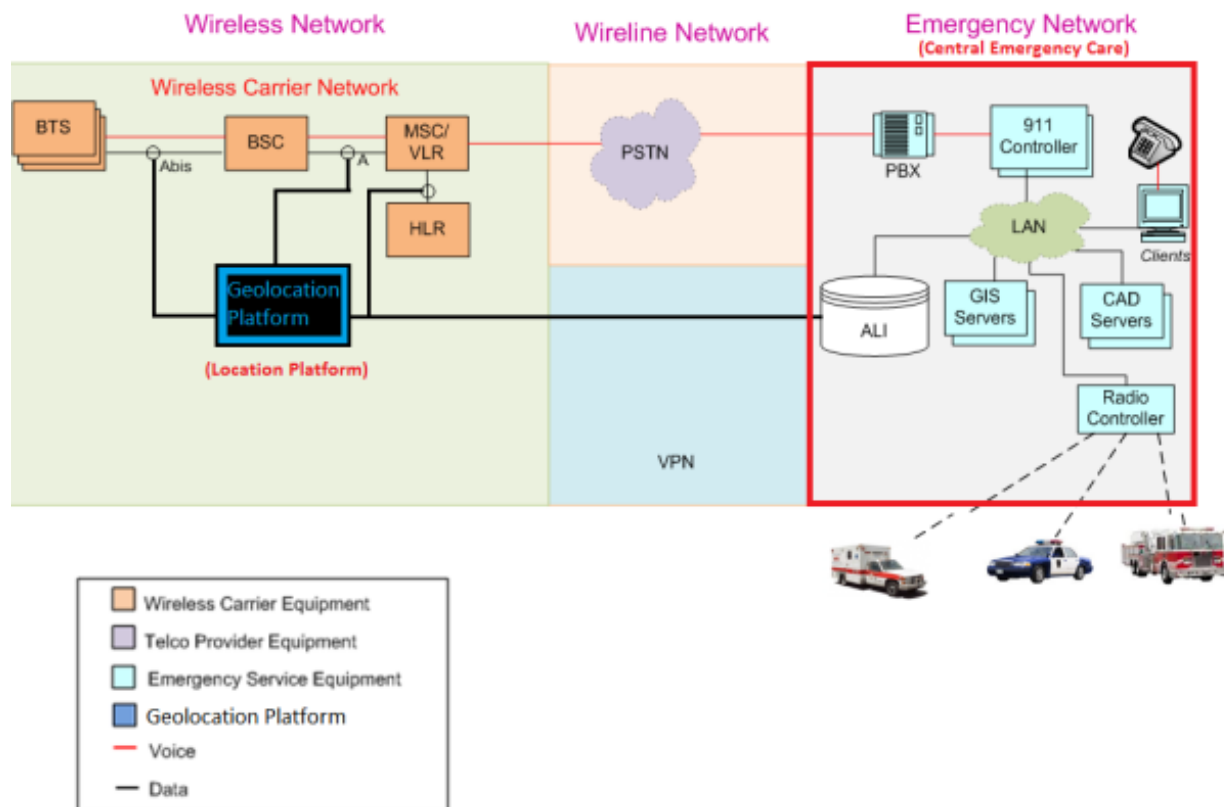


Figure 67 – Location of Emergency Calls

The solution needs hardware and software, database, operators and dispatchers for the Center for emergency calls, as well as location systems for calls made from fixed and wireless networks.

This solution locates emergency calls of fixed and wireless network automatically, and route them to qualified personnel with the latest technology equipment, showing the location information.

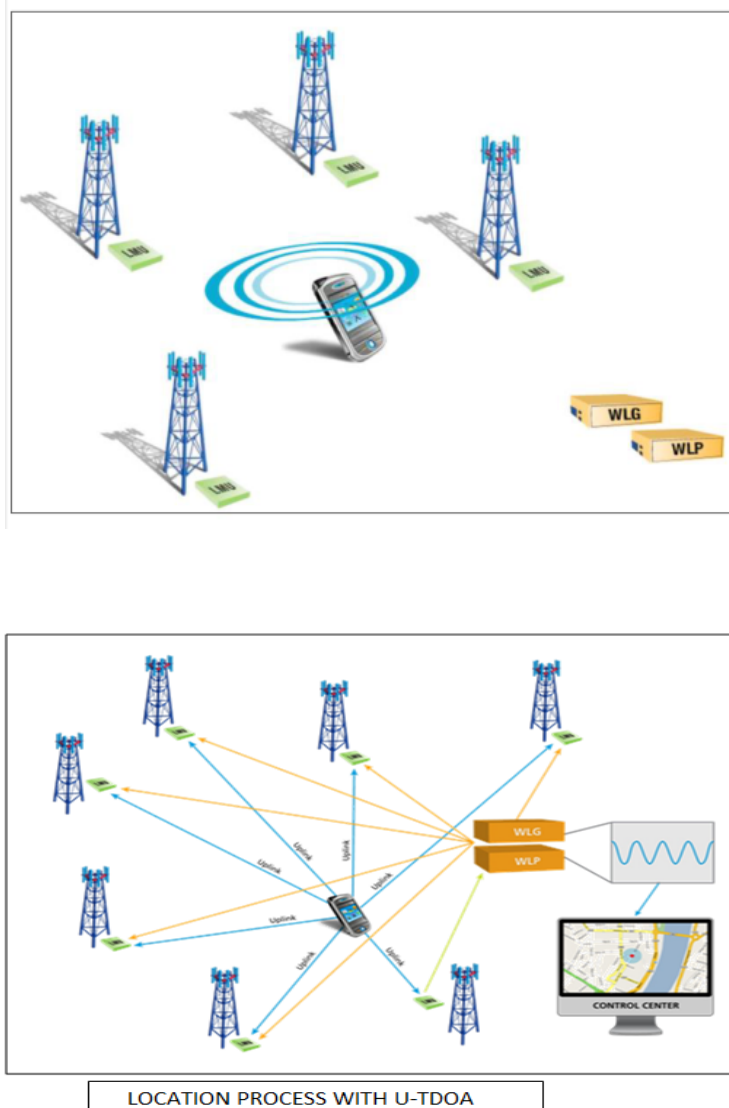
Considering that it's simple to obtain the localization of calls originating in fixed networks (just checking users address database), location technologies has been developed mainly for mobile environments, and must meet four essential characteristics:

1. High precision;
2. Establish a system that never fails;
3. Locate any mobile phone;
4. Operate in all environments (indoor, inside vehicles, in urban and rural areas).

One of the technologies used for location of mobile phones and devices is the technology "Uplink-Time Difference of Arrival "(U-TDOA), which provides highly accurate information, high performance, and low response time.

The operating mode of the U-TDOA technology is as follows:

- A radio signal emitted by the mobile device spreads in radial form at a constant speed (the speed of light);
- U-TDOA compares the time of arrival of the same signal between two base stations equipped with Measurement Units for Location (Location Measurement Units-LMUs);
- As the distance between the mobile device and base stations are different, the time of arrival is also different;
- When the measurements of three or more base stations are combined, it is possible to estimate the point where the probability is higher of finding the mobile device.



**Figure 68 – Location process with U-TDOA**

The location technology uses the difference in times of arrival or U-TDOA to determine the location of a mobile phone by comparing the times at which the signal of a mobile device up to special receivers installed in multiple cellular base stations.

Receptors are highly sensitive instruments; called Location Measurement Units (Location Measurement Units, LMU). They contain accurate and synchronized clocks that record the time a Radiofrequency signal arrives up to location. The results of different LMU are compared to determine the most likely location of the phone.

Under optimal conditions, where there is more density of base stations, U-TDOA technology locates mobile phones within a radius of 50 meters. The accuracy decreases in areas where there are less radio bases and therefore less LMU.

The U-TDOA method has several advantages among which include: accuracy, consistency and reliability. It is also the method of locating cell phones that has focused on security more precisely. Also the U-TDOA location technology is typically able to locate a mobile phone in less than 5 seconds.

The following figures show the location procedure of a mobile terminal:

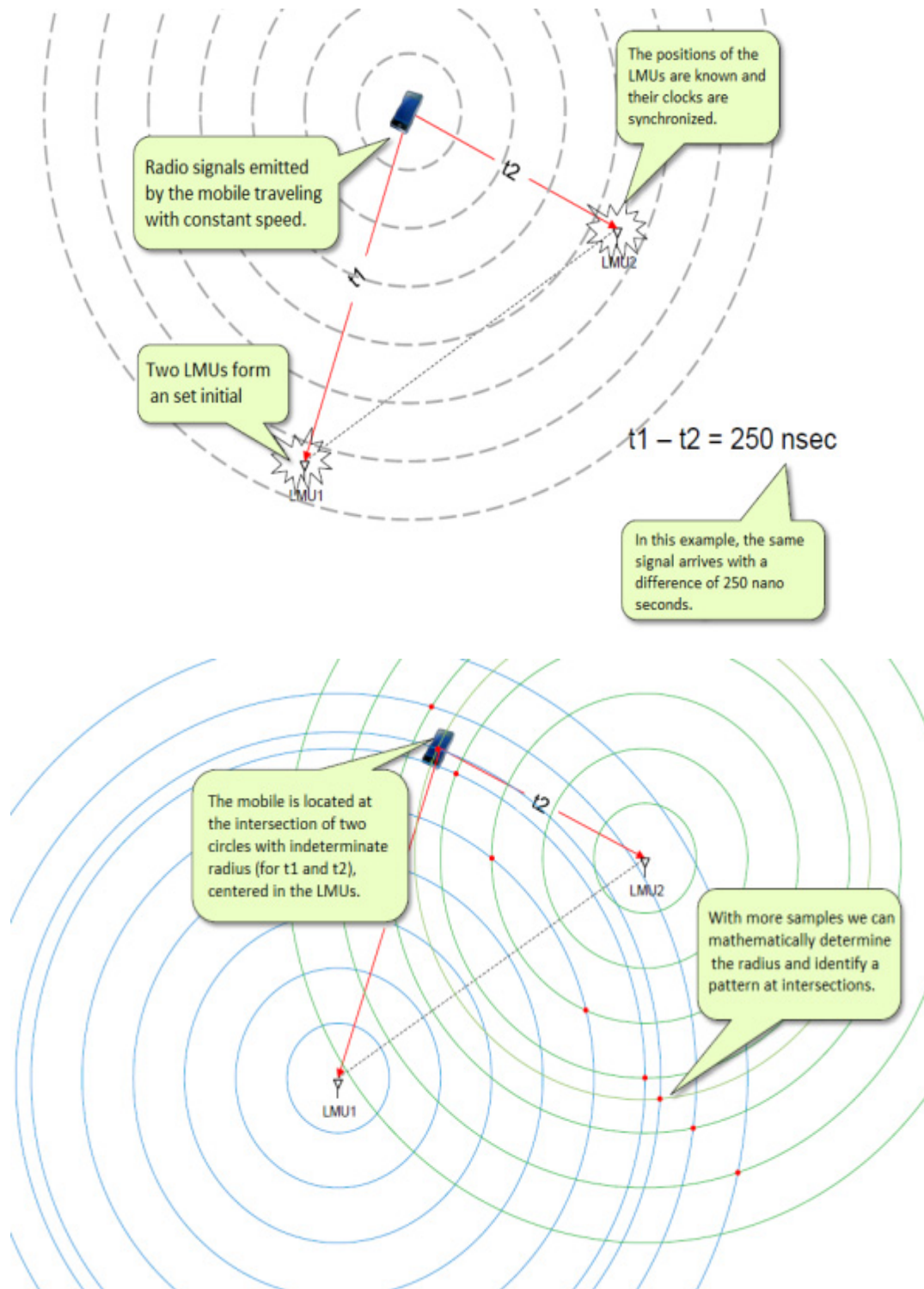


Figure 69 (1/2) – Location procedure of a mobile terminal



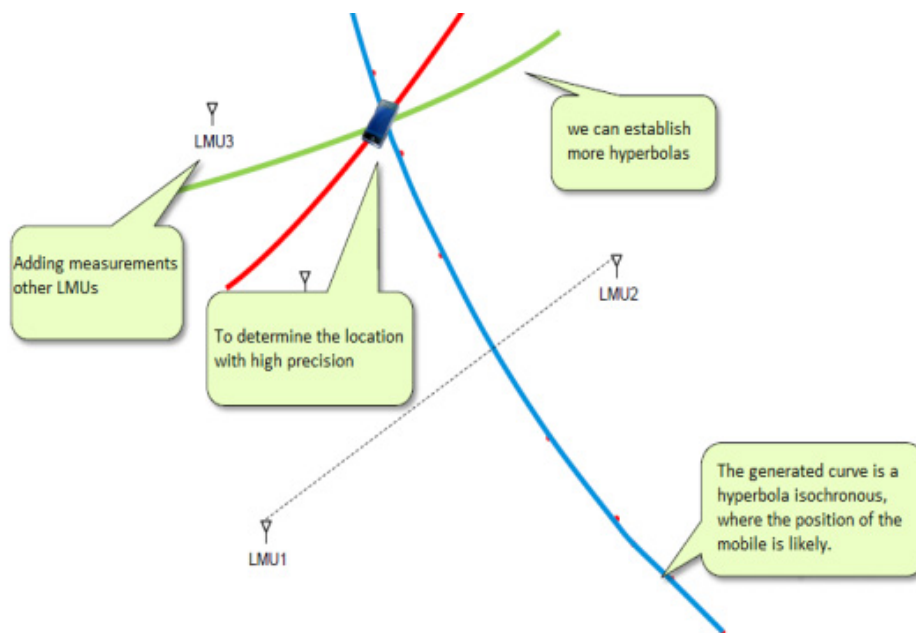


Figure 69 (2/2) – Location procedure of a mobile terminal

### National Alert System Using Cell Broadcast

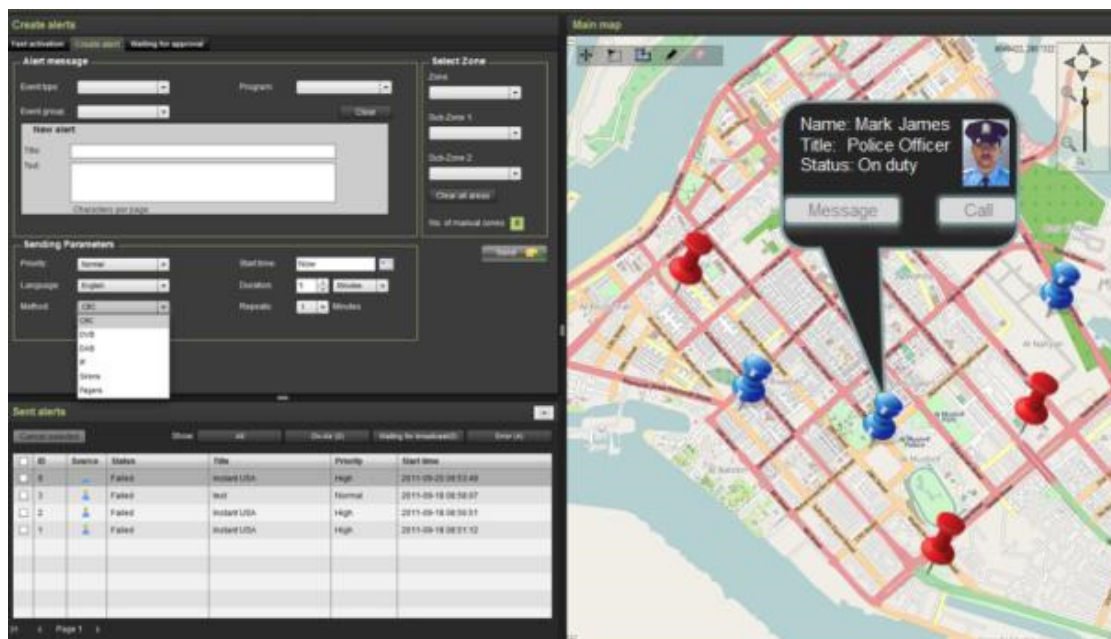
There are different types of solutions that are designed to effectively send messages to large numbers of mobile telephone users almost instantaneously while receiving input from the subscribers. Especially designed for local and national authorities to deliver urgent messages to large populations, the National Alert System can be used to inform the public about hazardous situations such as terrorist attacks, pollution outbreaks, storms, fires, traffic jams and accidents as well as minor events that are not immediately endangering the public safety and security such as water break, power break, construction work, etc.).

This solution not only enables swift responses from authorities but gives them the capabilities to provide a controlled and managed constant flow of information and instructions to the public using different channels depending on the events nature and status constantly.



Figure 70 – National Alert System Using Cell Broadcast

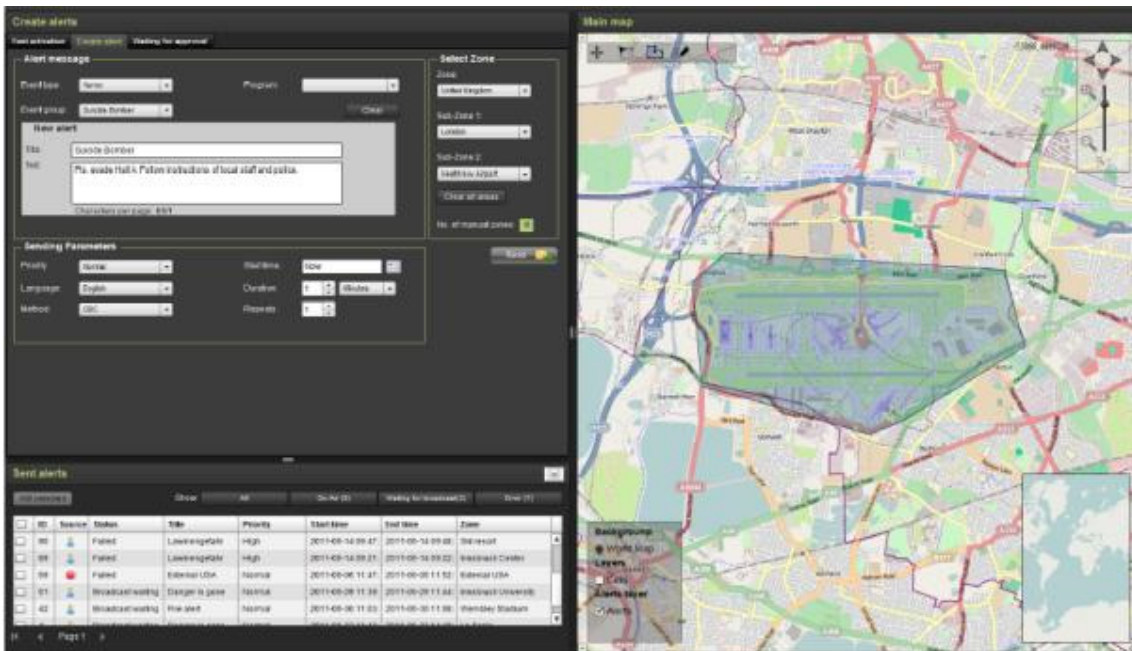
Moreover, it gives the authorities real-time segmented information based on their relevant departments (i.e., the police department, the fire department, etc.) using both cell broadcast technology as well as "Push IP".



**Figure 71 – Using integrated GIS engines**

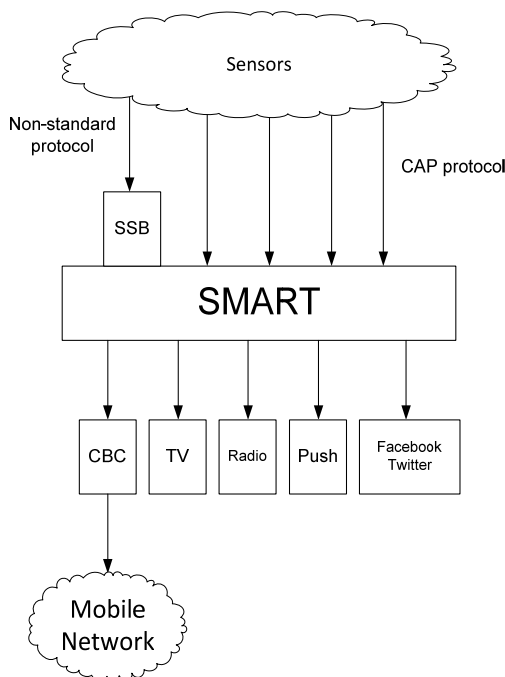
By using the integrated GIS engines, it enables the authorities to deliver the messages geo-targeted and to make it only available to the people in the need to get this information. Cell broadcast technology can deliver messages geo-targeted to the cellular antennas at the event's location. Furthermore, it is possible to deliver the information to fix IP addresses of billboards as well as to digital televisions.

The following figure shows Cell Broadcast Management software with a GIS engine that allows human operators to select specific geographic areas, to send the messages.



**Figure 72 – Cell Broadcast Management Software**

The proposed system architecture includes the use of a CBC (Cell Broadcast Center) directly driven by a SMART system. The architecture of the system can be summarized under the following diagram:



**Figure 73 – Architecture Cell Broadcast Center**

The various inputs, which could be either sensors or human operators, communicate with the system through standard interfaces that operate in protocol CAP (Common Alerting Protocol) which is based on XML and is used for the transmission of public warnings and emergencies.

In case of having non-standard interfaces, conversion is performed on the SSB entity (Sensor Service Bus) which facilitates communication to the SMART system from other systems that do not have support of CAP.

The SMART system also allows the creation of polygons that are targeted toward specific geographic areas of interest within which one wants to disseminate alerts. This definition is made from geo-referenced graphical interface. To this end, SMART has an updated database of the location of cell phone stations BSC / RNC and BTS / NodeB that automatically updates through the CBC (Cell Broadcast Center) that becomes the interface from the network mobile phone.

It is important to note that the system can be deployed under different topologies hence two alternative solutions. First, it is to have a centralized CBC such as in the case of Israel. Second, it is to have one CBC distributed such as in the case of Chile.

### Architecture with centralized CBC

This solution requires an updated network information from all the cells, which is crucial to ensure that the cells are correct in their respective polygon.

Citing the case of Israel, all mobile operators are required to update at least once per day by using the FTP protocol. After creating the polygons by using alert handler, the SMART system will define the BSC / RNC and BTS / NodeB that are relevant in its coverage area. The SMART system will then order the CBC to send the message directly to the relevant cells (BTS / NodeB). The key advantage of this strategy is that the administrator (for example, government agencies) has to centralize control of system interfaces and the overall system.

A centralized CBC handled by SMART system allows full control over the evolution of the system, allowing the inclusion of new communication standards in the CBC (LTE, femtocells, etc.), where and when available. Thus, the administrator (for example, government agencies) need not wait for mobile operators to update the CBC because this factor will be under his own control.

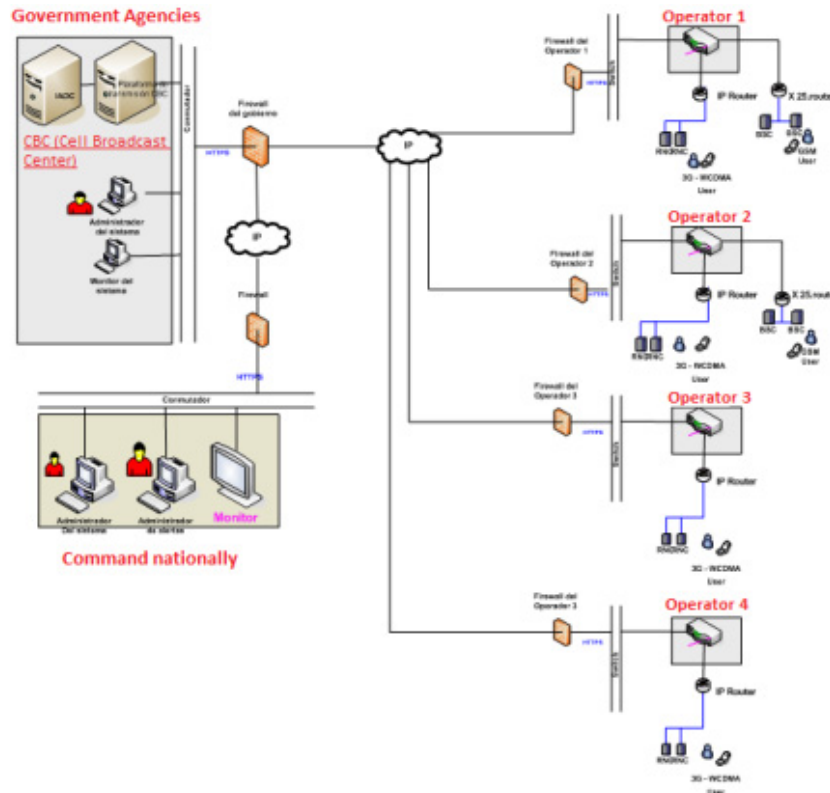


Figure 74 – Arch Diagram of solution with central CBC

### Architecture with distributed CBC

A distributed system would imply that although the SMART system is installed outside the network of the mobile operator, the CBC is deployed within it. As a result of this, the SMART system should have an interface for each CBC installed on each of the mobile operators. The advantages of such solutions focuses on the fact that mobile operators are not required to disclose information about the position and coverage of their cells. Because of this, it is necessary to develop mechanisms of cell load information to inform external system about the change of information in a cell.

This also implies strong consequences for the translation of the respective polygon geographic (longitude / latitude) to specific cells located within the respective area covered by the polygon. Dynamic changes in the radial structures (especially on 3G networks) need not be reported to the SMART system because sending messages CBC to BSC and RNC of operators will be managed within their own facilities. Additionally, mobile operators can also use the CBC for other commercial services. This also allows the operators to decide the vendor of CBC equipment.

However, as the intermediary will only transmit information respective of polygon to CBC (longitude / latitude) and not the ID information of the cell, an additional intermediate component between the intermediary and the CBC would be needed in the equipment room of the mobile operator. The component is called portal (gateway) CMSP. This component is responsible for translating the polygon information (latitude / longitude) to the ID of the respective cells of the relevant mobile operator. Each component in the portal (GW) CMSP will be customized according to the CBC interface to which ones connect.

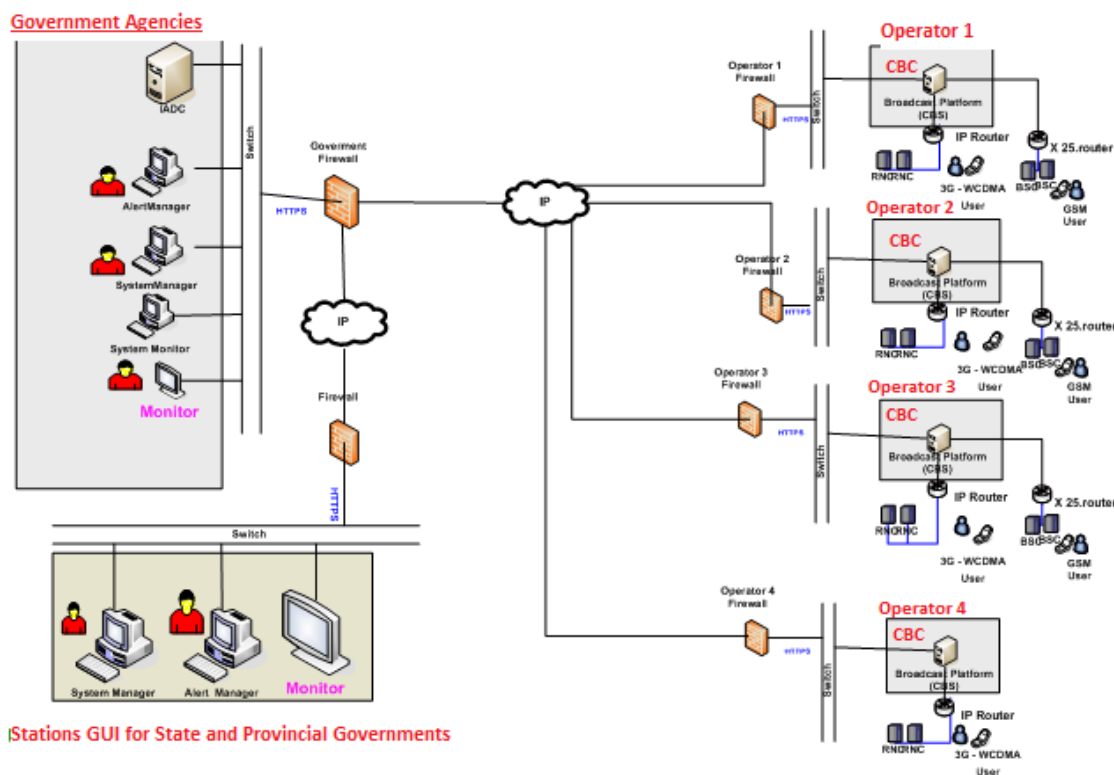


Figure 75 – Diagram of solution with distributed CBC (Cell Broadcast Center)

In this scheme operators can use a different brand of CBC for each of them, as one2many, Huawei, Alcatel-Lucent and others.



### 3.5 Education and tourism

The ICT infrastructure should also serve to improve aspects such as education and tourism; that is in general to ensure tangible economic growth such as higher standards of living and employment opportunities for its citizens.

Besides the known contribution of ICT to education, both classroom-based and distance-learning, the influence of the SCC will mean that the citizen will be placed in the center of the educational scenario. The perimeter of the physical space in which educational experiences develop is becoming increasingly more indefinite and liquid, by hosting more informal practices characterized by high density of social interactions.

The SCC itself has the potential to serve as a teacher; for example, cities that already have a strong historical or artistic component must be an open book for the citizens and visitors supported by ICT. The visions are cities increasingly more open to participation in a smart and spatially widespread temporal education: online learning systems, training by computer, support forums and collaboration with experts, information about job opportunities and meetings that promote retraining etc. Other functionality may also include the use of new information and communication technologies to develop virtual museums, digital public libraries, augmented reality, digital art, co-creation and other leisure activities and assisted real-time translation and cultural mediation.

Data analysis, mobility and ICT are part of the industry trends in travel and tourism. New computing tools and large volumes of data are being used to retain customers, improve operations and meet the service experience of travelers in hotels. For example, the Electronic Guides that are found included in mobile applications, allow the visualization and identification of points of interest for the tourist (municipalities, commerce, museums, churches and hotels) through the Geo Positioning systems. Reality Augmented services (later is extended the concept) have also emerged as new applications for mobile phones that provide information to tourists based on their experiences, geographic locations, and interests. The Smart Sustainable City concept could positively affect tourist arrivals with environmental or technological concerns. On the other hand, it may offer to tourists, as well as everyone involved in this business, updated and accessible information (location and hours of entertainment events, etc.).

### 3.6 Environment and waste management

The ICT infrastructure can establish an environmentally responsible and sustainable future which "meets the needs of today without sacrificing the needs of future generations". Aspects such as improvement of transport courtesy the ICT infrastructure and its applications, and an improvement in energy efficiency, can reduce pollution e.g.

The environmental sustainability of an ideal SSC could be achieved by upgrading the following infrastructure:

- Use the IoT technology to form a closed-loop management for the monitoring, early warning and control of pollution sources.
- Use distributed sensors to enhance the air quality and urban noise monitoring, to communicate with the public, and using mobile communication systems to strengthen the linkage between the supervision and inspection departments.
- Strengthen the real-time water quality testing network system constructed for reservoir, river, and residential building secondary water supply so to guarantee true real-time monitoring.



- Strengthen the sensing system construction for green belt of forests, wetlands and other natural resources, and timely access green resources situation combined with geospatial databases.
- Use sensor technology, communications technology and other means to improve the monitoring, control and management on the thermal energy and building temperature systems.

Through the improvement of an overall smart system, water, electricity, natural gas, coal, oil and other resources could be reasonably allocated and utilized. Sensors installed in strategic locations, territories and cities are improving the monitoring of environmental variables and disposing higher information for decision-making.

It is necessary to incorporate clean and responsible management of waste, thus the amount of waste produced by citizens is one of the future challenges within the concept of clean and sustainable cities.

For example, in the Dutch city of Groningen, a personal card is required before depositing wastes in a container. This personal card would record every time the user opening the lid and therefore assemble behavioural data of the user with the hope of encouraging responsible waste management<sup>42</sup>.

Another of these smart elements is the fill control, whereby when the container is full emits a signal that alerts the garbage collection service. In this way, routes and schedules are optimized, the time spent on garbage collection is improved. This process also saves energy and reduces CO<sub>2</sub> emissions by better organizing the transport and avoid the unwanted waste in the street by overfilling containers. These advantages are made possible by the incorporation of chips in containers, which generate appropriate signals by microwaves, providing all necessary information, such as temperature. If the container temperature passes from some determined degrees, the chip shall deliver signals to firefighters to avoid fire. This not only minimizes the risk, but also extends its useful life, with consequent cost savings.

### 3.7 Smart building, digital home

The city life does not end in public spaces like streets, squares, parks, etc. It also includes the life of the population in their own homes and in public and private buildings; that's what one calls a digital/smart home/building.

A smart building is the integration of building, technology, and energy systems. These systems may include building automation, life safety, telecommunications, user systems and facility management systems. Smart buildings recognize and reflect the technological advancements and convergence of building systems, the common elements of the systems and the additional functionality that integrated systems provide. Smart buildings provide actionable information about a building or space within a building to allow the building owner or occupant to manage the building or space<sup>43</sup>.

---

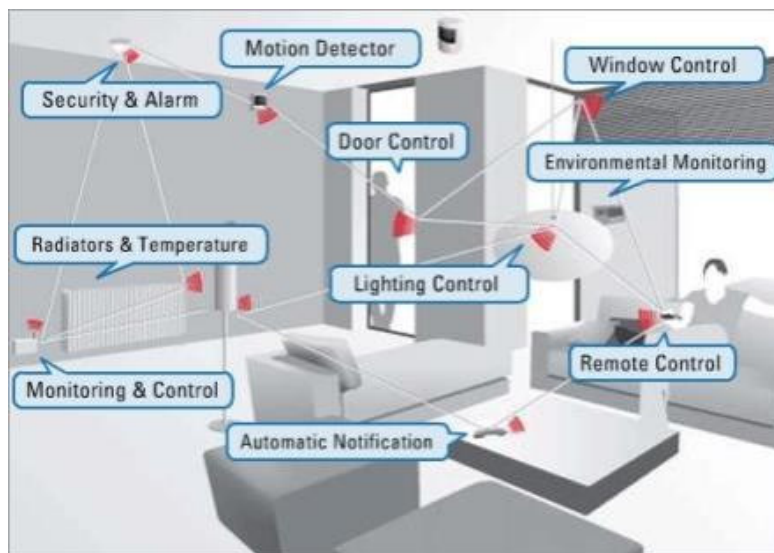
<sup>42</sup> An example of this use is the Dutch city of Groningen.

<sup>43</sup> <http://econtrol.me/Smart%20Building.html>



**Figure 76 – Intelligent buildings**

The future and the development of intelligent buildings are based on the following pillars: "Smart" objects with electronic chips embedded capable of receiving and transmitting information (e.g., Sensors), devices using remote control, communications favoring the transmission of information between devices and interactive and accessible interface to the users that allow the network used in homes to become easy to use (user-friendly), Intelligent Building Management Systems (IBMS), smart energy control systems for buildings and economic efficiency and impact on energy savings<sup>44</sup>.



**Figure 77 – Smart energy control systems for buildings**

<sup>44</sup> Technology Map "Smart Cities"; Ministry of Industry, Trade and Tourism of Spain.

### 3.7.1 Home energy management

#### Visualization service of consumed energy

The system is required to measure the consumed electric energy of each distributor, breakers the generated energy by solar cells, and allow to calculate the fee of energy and to inform the cable customer of the result. The current sensor is required to transmit measured data (consumed or generated electric power) to the radio terminal device by ZigBee or wireless fidelity (Wi-Fi) radio chip. The residential gateway (RGW) is required to store the data temporarily (e.g., for one day) and to upload the data to the collection server of sensor information.

The system is also required to present the cable customer with a regional power saving period, a power saving announcement, and information on power balance from a municipal office or power company. In other words, the system should not only display consumed/generated power. The system can provide, optionally, recommend services for power and cost saving, in line with the customer's power consumption pattern.

Furthermore, the system can optionally provide any additional support including regional ranking information of power saving or additional incentive services. The system is required to be operated on RGW at home and on a smart phone or tablet terminal, and in an outdoor environment through the cable portal function. The system is required to send the information by e-mail to the assigned address.

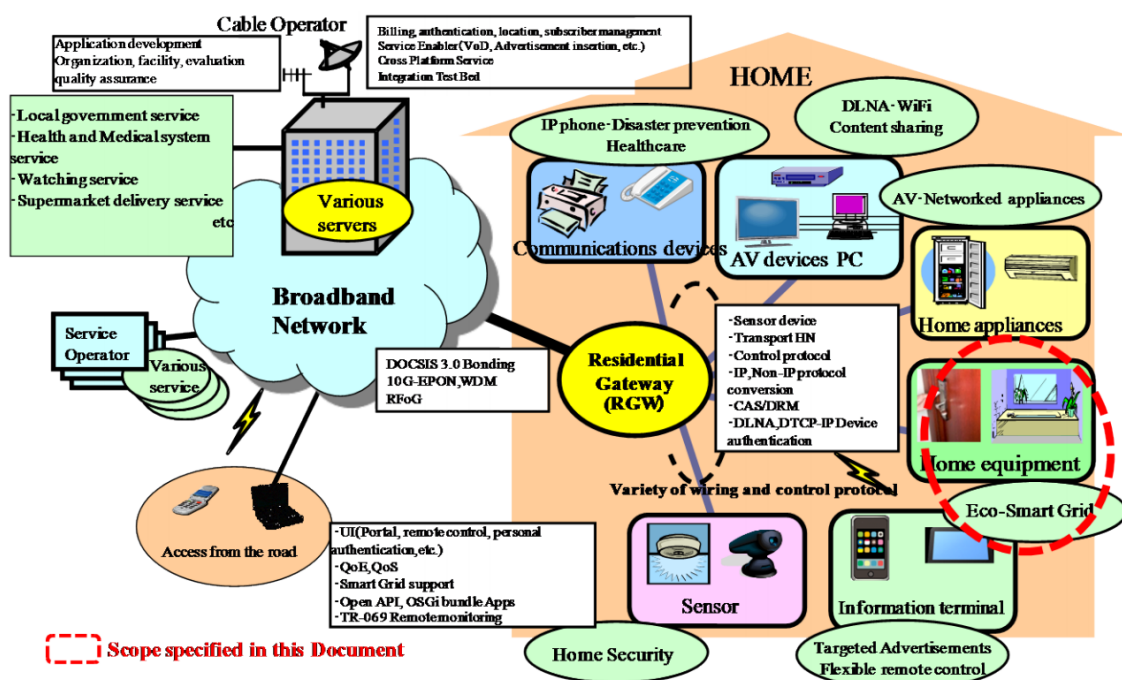


Figure 78 – RGW and related entities for home ICT services

Source: Technical Report of the Focus Group on Smart Cable Television.

#### Solar power cell maintenance service

This is an information service to the cable customer on the maintenance of the solar power cell. The system is required to report to the cable customer the necessity of surface cleaning, the existence of malfunction through the monitoring of past power generation record and comparison with regional standard generation value.

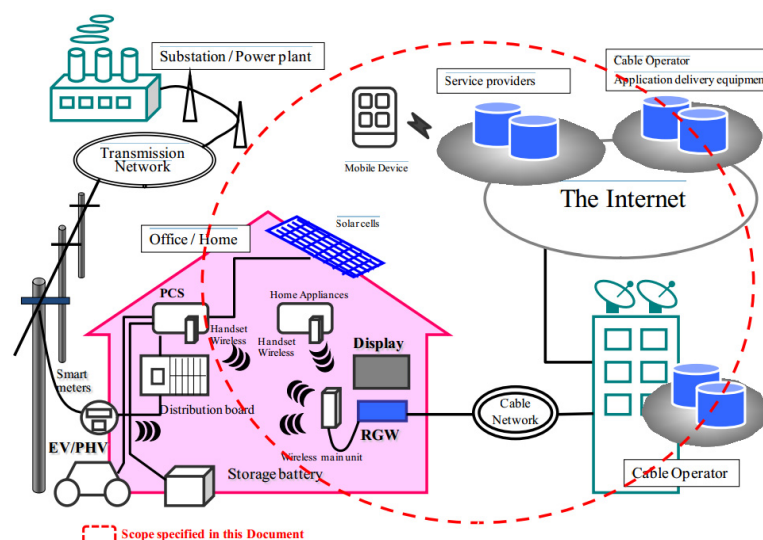
In general, the detection of the failure of the solar panel module is difficult; hence, it is normally left without maintenance even during the guarantee period. It is also useful for the customer to be informed that the trouble is caused by climate change or a stain/malfunction of the solar panel. The system has to report the result to the cable customer. In case of a home battery, the system has to provide the appropriate exchange date of the defective battery or advise on the economical usage of the battery based on a past operation record. The system must send the information by e-mail to the assigned address.

### Presentation items

The presentation items are shown below to realize the aforementioned services:

- 1 Electric power consumption (real time, every hour, past record, regional ranking);
- 2 Electric power generation (real time, every hour, past record, regional ranking);
- 3 Electric power fee (time zone, monthly, comparison with previous year);
- 4 Battery status (real time, charge/discharge record) and exchange date;
- 5 Usage report by the power company (regional power balance);
- 6 Malfunction of the solar power panel and/or necessity of cleaning;
- 7 Setting threshold of power consumption and control. Technical Report of the Focus Group on Smart Cable Television ITU-T FG Smart Cable Technical Report 5;
- 8 Alert indication over threshold, usage recommendation, sending e-mail;
- 9 Power saving schedule in region;
- 10 Economical usage information;
- 11 Contract detail with the power company;
- 12 Setting of presentation.

### High-level system architecture



**Figure 79 – Shows the high-level system architecture for home energy management services**

### Pre-conditions

- The residential gateway and measurement devices for power consumption should be provided in the customer premises.

- The interface conditions and transmission protocols (device discovery, capability check, data acquisition, etc.) between the measurement devices and the gateway, and between the gateway and the cloud should be standardized.
- The application for the visualization service of consumed power should be provided.
- The application download function should be provided in the application distribution system and the terminal devices.
- Data processing in the cloud should be available in real time by the application.

The terminal devices (RGW and mobile devices) should have a browser function to present data processing results.

### Main steps

- 1 The customer is able to download the application for the visualization service of consumed power in the terminal devices.
- 2 The customer selects the service (visualization service of consumed power) on TV or on a mobile device screen and logs using their ID and password.
- 3 At the selection of the service by the customer, the functions for the discovery of measurement devices and communication to the gateway are activated.
- 4 The measurement device reports the obtained data to the gateway function periodically or at the time of customer access.
- 5 The gateway function transfers the measured data to the cloud by the application, the cloud processes the data, and the results are conveyed to display terminals (TV or mobile devices) through the gateway function.
- 6 The terminals present the processed data on their screens.

## 4 *Planning the national deployment of ICT infrastructure for SSC*

---

Until today, the planning of a SSC is in the hands of the Government, although the private sector has been engaged in developing and implementing corresponding frameworks. It should focus on generating cross-cutting, inclusive and comprehensive strategies, using ICTs, to optimize the meeting of the diverse needs of the citizens.

The use of ICT in the planning of a smart sustainable city must be aimed at interrelating the complex systems that form an urban area (utilities, communications, production, information, infrastructure, vulnerability, etc.), as well as, proposing smart and inclusive solutions oriented to use efficiently and sustainably the resources required by the citizens, particularly the non-renewable ones (Figure 2).

In this sense, the challenge of planning raises the need to:

- design efficient management schemes for electricity consumption,
- monitor and rationalize the use of water,
- create control systems to reduce vehicular air pollution,
- design more interactive communication tools to meet the need of information, avoid physical movement of people, among other solutions.

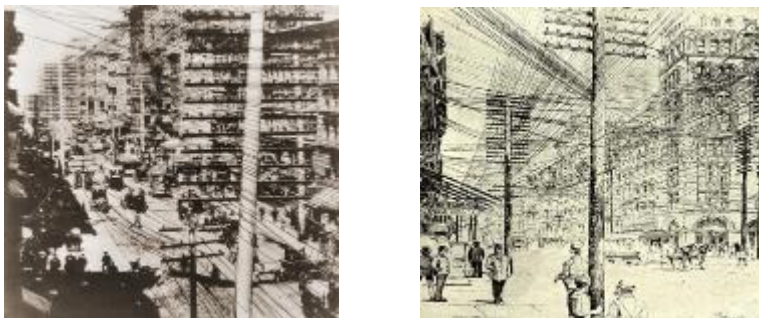


These solutions can be developed individually, but they must be transversal. It will allow to identify synergies and opportunities for improvement, reduce costs, seek the well-being of the population, and thus, achieve a smart sustainable city.

There are two aspects to consider during the strategic planning of the deployment of ICT infrastructure: first, the deployment of new ICT infrastructure itself; and second, the improvement of current ICT infrastructure using new technologies. In the first case, the strategies can be addressed both from the point of view of the previously mentioned stakeholders and also from the point of view of the ICT infrastructure itself as an object to be upgraded. The last point of view needs to include convergence strategies.

It is recommended that the formulation and implementation of policies and strategies are followed by a multi – stakeholder (i.e., public and private, local and supra- and commercial and non-commercial) approach. However, conflicting interests from different stakeholders may arise. For instance, there are differences of views between local governments and operators about the consideration of providing free basic connectivity, since it can be seen as a form of unfair competition by the operators, rather than a complement and a new civil right.

Regarding the point of view of infrastructure as an object to be upgraded, there is a natural predisposition to match the classical networks (roads, energy, sanitation, etc.) with digital technologies of communication and information. It is appropriate to note that the communication networks have an impact on the physiognomy of cities, as demonstrated in the following images of New York in the late nineteenth century where the web of high telegraph and telephone cables brand the image of a networked city.



**Figure 80 – New York (United States) at the end of the XIX century**

The following images show the communication networks' impact on the physiognomy of some cities in the developing world in the XXI century.



**Figure 81 – Manila (Filipinas) and Vijayawada (India) at the beginning of XXI century**

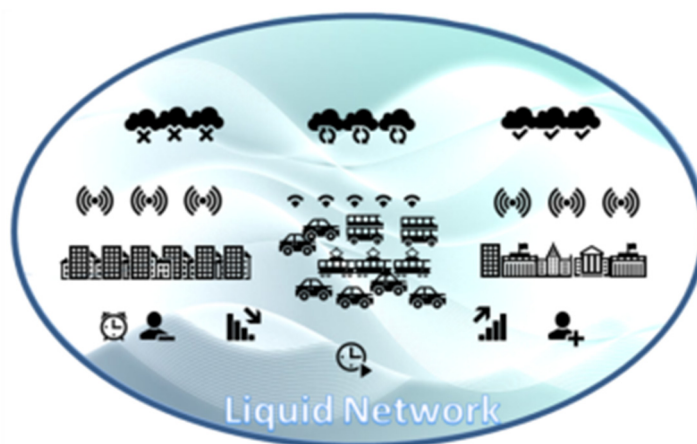


As demonstrated above, many of the existing urban environments are overrun by thousands of cables with little regards to safety and efficiency. Therefore, it is imperative that communication infrastructures must exist in an affordable and accessible way. Successful strategies could then be replicated based on the given specific measurements such as in the case of laying cable in the suburban zones.

Currently, infrastructures in cities should overcome the following shortcomings such as; the lack of exploit of synergies among public services and the communication restrictions; the uneven bandwidth capacity among different providers and so on.

To remedy these defects, one should aim to create a strategic model from a holistic approach, with particular actions that would improve the adaptation ability of the existing, infrastructure, which would in turns supports and builds the SSC.

The existence of these limitations can be conceptualized with the idea of "Liquid network", which is an approach to describe the citizen's communications traffic and their daily trends. There is a behavioural pattern of the online communications traffic in a fluid form that generates "waves" of data traffic. These waves accompany with the movement of connections (for example from the outskirts of the cities to work centers) or a movement related to the time (concentration of masses, i.e., in stadiums for sporting events).



**Figure 82 – Liquid networks**

Clearly, it is a challenge to have infrastructure adaptable to large daily changes according to the traffic needs as described. Strategies are needed to handle a "Liquid Network" urban character, in order to meet individual bandwidth requirements and to have the functionality of mobile usage, as well as, strong processing capacity in different areas of the city, according to each time of day.

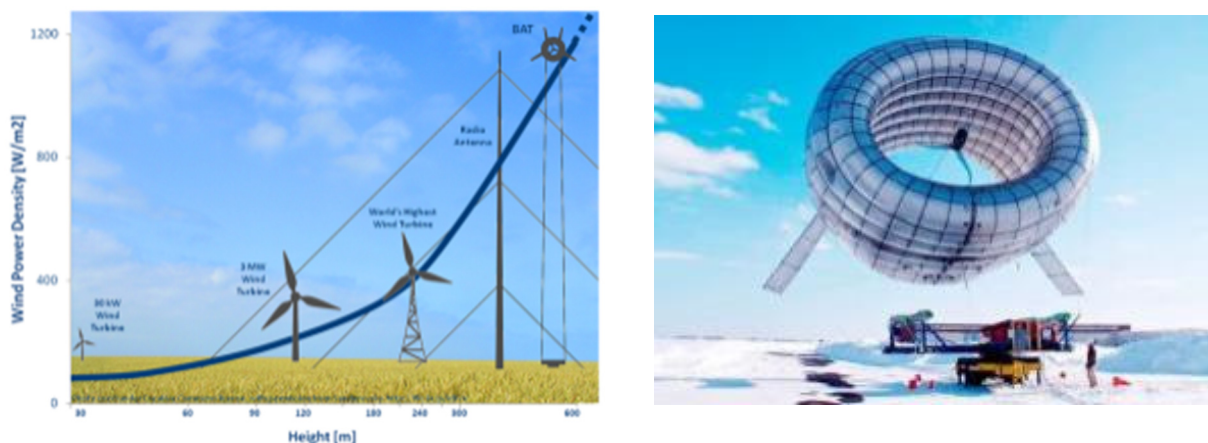
Nowadays, issues such as Smart Radio, Mobile Mesh Networking, Mobile Ad-hoc Network (MANET), Mesh Radio and others are nicknames used to designate different technological aspects of a future scenario, where the user terminal devices have sufficient capacity to constitute networks of varying topology and also perform the functions of both the structural nodes of network (such as routers and servers) and customers.

The possibilities for the deployment of services in such scenario are immense and could correct many of the defects mentioned before. For example, each device in a MANET has the freedom to move independently in any direction. It enables dynamical changing over new conditions of link between the devices. Each device is uncoupled from traffic and therefore, performs missions of a router.

One of the main challenges in the build time of a MANET is to equip each device to continuously maintain the information required for routing. Such networks result from the combination in each of the terminals or nodes of the layers identified ICT infrastructure, i.e., the data communication and the detection layers, and they can operate independently or be connected to the Internet.

Other infrastructure to be considered is the HAPS (High-Altitude Platform Station). Its ability to vary the beam communication is highly adaptable in an urban environment, directing more bandwidth to where it is most needed in the daily evolution of zonal needed for data traffic. Although, its commercial use is now limited and focused on remote areas (such as Alaska), ITU-R has already defined the total area coverage of a HAPS aircraft in the bands 47/48 GHz and have divided it into three areas: urban, suburban and rural (they are needed to ensure consistent broadband users throughout the visibility zone on the floor of the HAPS). The Urban area coverage extends between 36 and 43 km from a point directly under the platform. Users of these areas can be portable modems. The Suburban Urban Area Coverage is up to 76.5 / 90.5 km, depending on the altitude of operation of the HAPS. Users from suburban area coverage should use high gain directional antennas and transmit power.

Besides, there are also business technology initiatives that take advantage of the height, both for energy production and for the establishment of communication nodes (and meteorological studies). One example is the BAT (Bouyant Airborne Turbine) that fails high winds to produce power and to transmit it to land routes subject to the anchors. Clean Energy + Point Communication are a typical combination of infrastructure for future SSC.



**Figure 83 – Example is the Bouyant Airborne Turbine (BAT)**

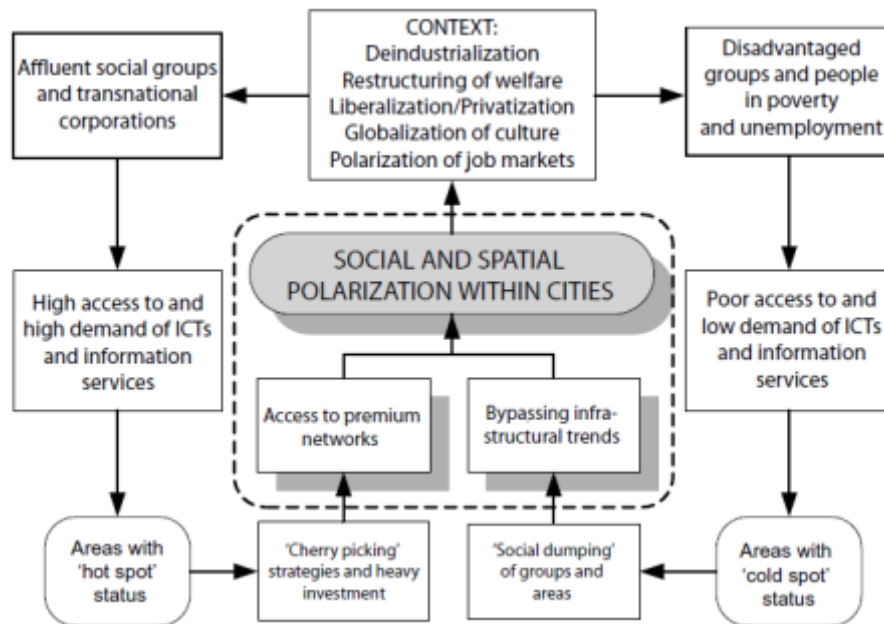
Image of BAT near to the ground and explanation of the height gain

## 4.1 Urban growth in the knowledge era and the digital divide

There is a common census on how important knowledge, technology, and innovation are in contributing to the success of a city. However, differences can be drawn from debating what are the key factors that would influence knowledge and innovation<sup>45</sup>.

<sup>45</sup> This document focus on the "hard" part associated with the influence of business; however there are explanations due to the influence of persons (talented and creative people changing the structural design of cities).

Therefore, any strategy of planning for the ICT infrastructure deployment should take into account aspects such as combating the digital divide within cities.



**Figure 84 – Social and spatial polarization within cities**

A scheme of how trends in telecommunications are underpinning the shift to more socially polarized cities.

The authorities should be aware of the polarization problem caused by the lack of infrastructure and the differences in economic and social conditions within cities. Therefore, it is recommended that communication infrastructure projects should be given a priority status in the political agenda and receive an adequate amount of public resource for these projects to reach maturation.

## 4.2 Strategies for the deployment of digital/ICT infrastructure

An approach to establish deployment strategies is to study the interactions between the Supply and Demand components. An adequate offer of connectivity boosts the demand, while more demand increases and improves the supply (a desirable virtuous circle). Taking that into consideration, the content of this section should not focus only on supply strategies, but also on demand strategies. Moreover, appropriate strategies in the regulatory and financial aspects should also be included.

### 4.2.1 Strategies to stimulate the supply

Governments may own existing infrastructure and share it with private operators in order to develop new projects.

- Telecommunication networks: Governments may own existing wireless accesses and share their network capacity. Projects are usually focused on facilitating the administrative tasks of local government and providing connectivity to educational institutions.
- Poles, lampposts, buildings and other high places: High points are necessary to place antennas and other infrastructures.
- Duct as sewers, gas pipes and others: They are especially important for transport networks, such as sewers are used for fiber optic laying. There may be versatile ducts for all networks (electricity, gas, telecommunications, air conditioning and water).

- Public roads: Road networks facilitate the laying of telecommunication transmission lines.
- Traffic light's networks: Traffic lights can be used for wireless connectivity. In fact, there are initiatives that use preinstalled infrastructure for traffic control network. This type of network has centralized intelligence that demands telecommunications for the vehicles control system.

#### 4.2.2 Strategies to boost the demand

ICT are demanded for its utility. The services and valuable content are what provide meaning and utility to its infrastructure. Without infrastructure, the content and services do not exist. The mutual dependence of both infrastructure and content is what configures its development.

When governments intervene on infrastructure that supports ICT, they are concerned about two aspects: (i) management of services and (ii) establishment of good relationships with the citizens

- Give content to the demand: Currently, the biggest boost to the demand for ICT comes from the possible exploitation of the broadband services such as VoIP, IPTV, monitoring camera applications, video streaming, augmented reality, video conferencing, etc. In this sense, the government can stimulate the demand by using those tools and providing content over the network.
- Train users in the use of ICT: The intervention may be oriented to improve both disposition of consumers to use technology (since what is not known is not appreciated) and increase their capabilities.
- Provide connectivity: Hardware, software, appropriate contents as well as knowledge and skills to micro, small and medium enterprises (SME) should also be provided.
- Give direct subsidy: First, government can subsidy the User Final System (directed to the terminal such as the PC or to the modem). This kind of subsidy is usually used on educational institutions. Second, government can subsidy the access itself.
- Provide public free access at municipal level (it means a full connection subsidy). This is increasingly widespread and funds will usually come from supranational contributions canalized by regional and local governments.

#### 4.2.3 Regulation and financing

No infrastructure deployment strategy can forget the regulation and financing aspects. In markets involving utility networks such as telecommunications, regulation is essential.

The regulatory institutions are different according to the national law. They are affected by the type of State (unitary, federal or confederal), and also by the integration of a country. Strong integration will lead to supranational regulations to be applicable in the whole country.

The regulatory role of local governments can vary depending on the countries, and it can be extremely relevant in countries that are highly decentralized. Local government's capacities to involve in regulation and financing of city infrastructures may vary depending on their correlated legal-institutional frameworks and jurisdictions. An example would be the United States, where each state has been given extensive jurisdictions over the telecommunication infrastructures.

The regulatory control of natural monopolies involves the encouragement of competition, the efficient use of scarce resources, ensures the quality of services and the defense of the users' rights. Although this issue is a matter of sectorial management (for instance, a Ministry), local governments come to venture into these issues.

Thus, besides the sectorial normativity, there are other regulations which can be affected. For example, there are countries in which their interest access is governed by community centers. While formally in other countries these centers are not regulated by the telecommunication authority. Instead, there may be local regulations (i.e., civil defense and protection of children) that affect the sector for instance by establishing a minimum number of posts, the distance between posts or by filtering some Internet content. Then, at the municipal level, in virtually all cases and countries, there are regulations exclusive to cities in building permits, use of rights of way, visual impact (antennas), urban impact, environmental impact, operating licenses, zoning and other issues related with the internal structure of the city itself. In other cases the city government promotes infrastructure deployment, by allowing (with or without cost) the use of public structures such as poles, street lights, tunnels, ducts or roads, etc.).

Thereby, local governments can play a very important role, since rigid normativity on certain facilities (air, antennas, ducts) inhibits the deployment of networks. In the same way, high costs of the right of way increase the cost of infrastructure and the corporate management.

In cases when governments deploy infrastructure projects, financing strategies are very heterogeneous. Even though, all of them are public initiatives, not all financial models will use taxation. The main funding mechanisms that can be used are:

- From taxes: It is one of the most important source of public funding. It is criticized by opponents of the government intervention, especially when governments intervene on areas where there is already telecommunication access.
- Redeemed for taxes (tax or rates): It happens when government taxing rights (i.e., rights of way) are exchanged for infrastructure development or services. Another form of redemption is tax relief to stimulate the infrastructure deployment of some operators. An alternative form of this type of funding mechanism is "tax works" where operators develop infrastructure in exchange of not paying some taxes (equivalent to the cost of the infrastructure).
- Loans + free cash flow: It is a mechanism comparable to the financing of any private project, where the initial capital comes from the financial leverage from partners. In this case, the government can appear as the first guarantor of loans, either directly or appearing as the main customer. Subsequently the project can try to sustain itself by the received revenue as a compensation for their services.
- Government as a major customer: Deployment projects can be funded by the income provided by governments, such as the city government.
- Advertising: It refers to the funding mechanism from Internet contents: paid access and advertisement financing. Part of the revenues from the two concepts may end in the government coffers.
- Utility allowance: It refers to using funds collected from other public service (mainly from electricity distribution service) to maintain telecommunications infrastructure projects. However, some regulations prevent these cross-subsidies.
- Corporate donations: As a form of social responsibility, there may be private donations from businesses.

- **Agreements with companies:** Sometimes, private companies offer a portion of its capacity to the public free of charge.
- **National or multinational Subsidies:** It is not rare to see municipal or supra-regional projects funded with capital from Central Government or multinational organizations.
- **Cooperative projects:** Cooperative wireless broadband networks are a common phenomenon. However, it does not always have municipal support or intervention. In fact, sometimes the local government ends up with a project that was originally created as a cooperative and community project. In Latin America, there are cooperative models related to municipal action; in some countries cooperative telecommunications companies have their origin in a local government intervention.

### 4.3 Evolution to become a Smart Sustainable City

Evolution occurs from different start points (depending on the current development of each urban area). It is better to study how the more advanced cities evolved, in order to replicate this evolution in less developed cities. For instance, as it can be seen earlier in this chapter, in 1887 telegraph and telephone cables in New York City were tangled over the outline of urban roads. Nearly 130 years later, an identical phenomenon occurs in the developing world. That is why learning from the past results are necessary. In the same way, many other lessons can be learnt from the cities that are approaching to the idea of SSC.

It is not necessary to go through each stage in the evolution to become a SSC. In this regard, it will be useful not only to pose an ideal model for SCC, but also to identify specific cities that are moving toward that goal. Even if these cities haven't reached the model completely (must be noted that the SCC, as all human work, can be improved on, and therefore, it will be a moving target, under constant improvement). In that way, other cities can replicate their strategies, correct errors, ignore delay factors and accelerate the followed steps.



## Annex A

### Abbreviations

3GPP	3rd Generation Partnership Project
ADC	Analog Digital Converter
ADSL	Asymmetrical Digital Subscriber Line
AISUWRS	Assessing and Improving Sustainability of Urban Water Resources and Systems
AMI	Advanced Metering Infrastructure
ARM	Architecture Reference Model
ATM	Asynchronous Transfer Mode
BAT	Bouyant Airborne Turbine
BEMS	Building Energy Management System
BSC	Base Station Controller
BTS	Base Transmitter station
CAGR	Compound-Annual-Growth
CALM	Continuous Air interface Long and Medium range
CAP	Common Alerting Protocol
CBC	Cell Broadcast Center
CDMA	Code Division Multiple Access
Cell ID	Cell Identifier
CME	CALM Management Entity
CMSP	Common Mapping Production System
CO	Central Office
CO	Communication Operator
CPU	Central Processing Unit
CRM	Customer Relationship Management
DAB	Digital Audio Broadcasting
DC	Direct Current
DCIM	Data Center Infrastructure Management
DER	Distribution Energy sources
DG	Diesel Generator
DNS	Directory Name Server
DSL	Digital Subscriber Loop

DSLAM	Digital Subscriber Line Access Multiplexer
DSRC	Dedicated Short-Range Communications
DWDM	Dense Wavelength Division Multiplexing
EC	European Commission
EDGE	Enhanced Data for GSM Evolution
EFC	Electronic Fee Collection
EMS	Emergency Management System
EPR	Electronic Patient Records
ERP	Enterprise Resources Planning
ETSI	European Telecommunications Standards Institute
EV	Electrical Vehicle
EVDO	Evolution Data Only
FTTB	Fiber to the building, business, or basement
FTTC / FTTK	Fiber to the curb/closet/cabinet/kerb)
FTTD	Fiber to the desktop
FTTD	Fiber to the desktop
FTTE / FTTZ	Fiber to the telecom enclosure
FTTH	Fiber to the home
FTTLA	Fiber to last-amplifier
FTTN	Fiber to the neighborhood/node
FTTP	Fiber to the premises
FTTx	Fiber to the X
FTTZ	Fiber to the zone
GEPON	Gigabit Ethernet Passive Optical Network
GHG	GreenHouse Gases
GPON	Gigabit Passive Optical Network
GPRS	General Packet Radio Service
GPS	Global Positioning System
GSM	General System for Mobile communication
GW	GateWay
HAN	Home Area Network
HAPS	High-Altitude Platform Station
HDR	High Data Rate
HEMS	Home Energy Management System

HSDPA	High Speed Data Packet Access
HSPA	High Speed Packed Access
HVAC	Heating, Ventilation, & Air Conditioning
IaaS	Infrastructure As A Service
IBMS	Intelligent Building Management Systems,
ICT	Information and Communication Technologies
IEEE 1901	It is a standard from IEEE
IME	Interface Management Entity
IMT	International Mobile Telecommunications
IO	Infrastructure Operator
IP	Internet Protocol
IPS	Intrusion Prevention System
IPTV	Internet Protocol based Television
IR	Infrared
ITS	Intelligent Transport System
ITU	International Telecommunication Union
LAN	Local Area Network
LDR	Low Data Rate
LEDs	Light Emitter Diodes
LMU	Location Measure Units
LTE	Long Term Evolution
M2M	Machine to machine
MAC	Medium Attachment Control
MAN	Metropolitan Area Network
MANET	Mobile Ad-hoc Network
MDR	Medium Data Rate
MELT	Metallic Loop Test
MEMS	Micro-Electromagnetic devices
MPLS	Multiprotocol Label Switching
MPLS-TP	Multi-Protocol Label Switching – Transport Profile
MSAN	Multi-service access code
MV/LV substations	Medium Voltage Low Voltage
NEM	Network Management Entity
NO	Network Operator

OBU	On Board Unit
OEM	Original Equipment Manufacturing
OLN	Optical Line Terminal
OLT	Optical Line Termination
ONUs	Optical Network Units
OSI	Open Systems Interconnection
PAN	Personal Area Network
PC-LAN	Personal Computer Local Area Network
PHY	Robust radio
PM2.5	Particulate matter air pollution
PON	Passive optical network
POTS	Plain Old Telephone Service
PSTN	Public Switch Telephone Network
PtP	Point to point
PUE	Power Usage Effectiveness
QoL	Quality of Life
QoS	Quality of service
QR	Quick Response
RF	Radio Frequency
RF-ICs	Radio Frequency-Integrated Circuits
RFID	Radio Frequency Identification Devices
RNC	Radio Network Controller
ROADM	Remote Optical Add-Drop Multiplexing
ROI	Return on investment
RSP	Retail service provider
RSSI	Receive Signal Strength Indicator
RSU	Road side unit
SaaS	Software as a Service
SAP	Service Access Protocol
SCADA	Supervisory Control and Data Management
SDDC	Software-Defined Data Center
SDH	Synchronous Data Hierarchy
SGTF	Smart grid task force
SMARTIE	Secure and Smarter Cities Data Management

SME	Small and medium enterprises
SMW	Smart water management
SNS	Social Networking Site
SONET	Synchronous Optical Network Technologies
SSB	Sensor service bus
SSC	Smart Sustainable Cities
STaaS	Storage as a Service
TA	Timing Advance
TMN	Telecommunication Management Network
TP	Transport Profile
UGROW	Urban GROundWate
UMTS	Universal Mobile Telecommunications System
U-TDOA	Uplink-Time Difference of Arrival
UWB	Ultra WideBand
VDSL	Very high bit rate Digital Subscriber Line
VoIP	Voice over IP
VPN	Virtual Private Networks
VPP	Virtual Power Plant
WAN	Wide Area Network
W-CDMA	Wideband - Code Division Multiple Access
WDM	Wavelength Division Multiplexing
WG	Working Group
WiFi	Wireless Fidelity
WiMAX	Worldwide Interoperability for Microwave ACCess
WLAN	Wireless Local Area Network
XDSL	X Digital Subscriber Line
XML	Extensible Markup Language

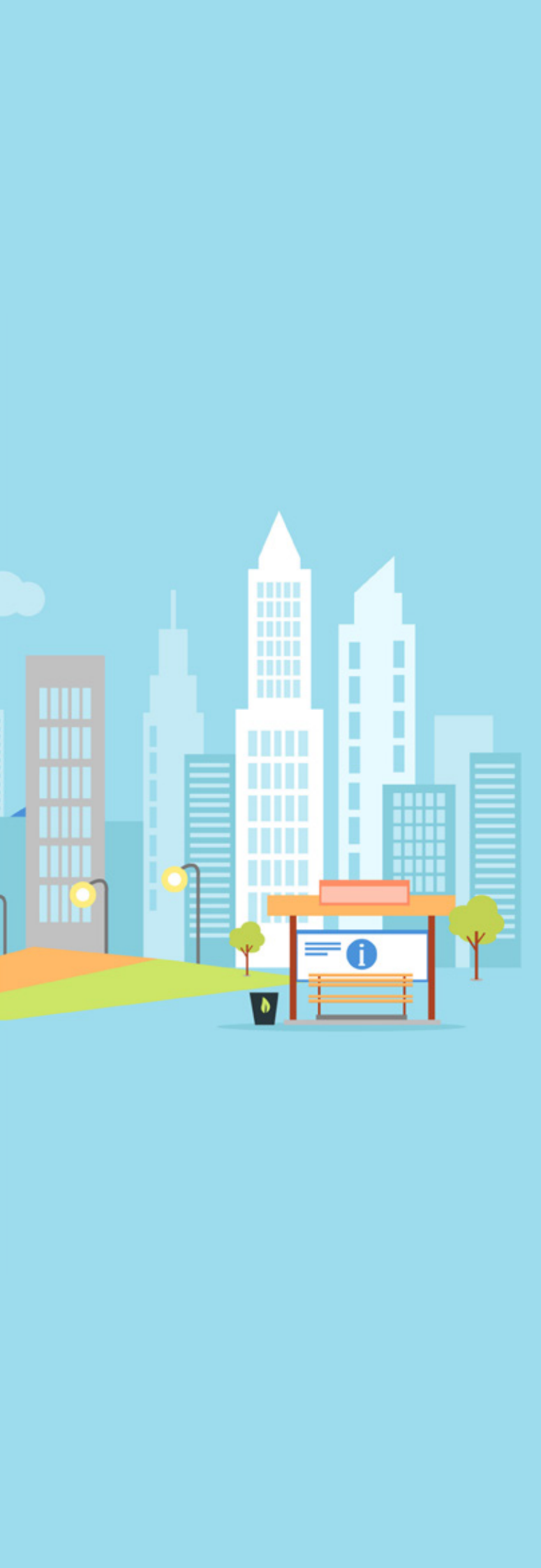
## Appendix I

### Bibliography

- [ITU-T FG-SSC-0146] Agreed definition of a Smart Sustainable City, Focus Group on Smart Sustainable Cities, 2014
- [ITU-T FG-SSC-0029] Technical Report on "An overview of smart sustainable cities and the role of information and communication technologies"
- [ITU-T FG-SSC-0345] Technical Specifications on "Setting the framework for an ICT architecture of a smart sustainable city"
- [ITU-T FG-SSC-0146] Technical Report on "Setting the stage for stakeholders' engagement in smart sustainable cities"
- [ITU-T FG-SSC-0113] Technical Report on "Cybersecurity, data protection and cyber resilience in smart sustainable cities"
- [ITU-T FG-SSC-0122] Technical Report on "Smart water management in cities"
- [ITU-T FG-SSC-0136] Technical Report on "Intelligent sustainable buildings for smart sustainable cities"
- [Recommendation ITU-T L.1300] Best practices for green data centers
- [Recommendation ITU-T L.1310] Energy efficiency metrics and measurement methods for telecommunication equipment
- [Recommendation ITU-T L.1320] Energy efficiency metrics and measurement for power and cooling equipment for telecommunications and data centers
- [Recommendation ITU-T L.1340] Informative values on the energy efficiency of telecommunication equipment
- [Recommendation ITU-T L.1400] Overview and general principles of methodologies for assessing the environmental impact of information and communication technologies
- [Recommendation ITU-T L.1410] Methodology for environmental life cycle assessment (LCA) of information and communication (ICT) goods, networks and services
- [Recommendation ITU-T L.1500] Framework for information and communication technologies and adaptation to the effects of climate change
- [Recommendation ITU-T L.1501] Best practices on how countries can utilize ICTs to adapt to the effects of climate change







# 3.2

## Setting the framework for an ICT architecture of a smart sustainable city

## Acknowledgements

These Technical Specifications were researched and written by Leonidas Anthopoulos (Technological Education Institute of Thessaly), Paolo Gemma (Huawei), Ramy Ahmed (National Telecom Regulatory Authority, Egypt), Ziqin Sang (Fiberhome Technologies), Flavio Cucchiatti (Telecom Italia), Zhen Luo (Fiberhome Technologies), Jia Guo (Fiberhome Technologies), Lei Gu (China Telecom) and Yuanyuan Liu (China Unicom), as a contribution to ITU-T Focus Group on Smart Sustainable Cities (FG-SSC).

Additional information and materials relating to this report can be found at: [www.itu.int/itu-t/climatechange](http://www.itu.int/itu-t/climatechange). If you would like to provide any additional information, please contact Cristina Bueti at [tsbsg5@itu.int](mailto:tsbsg5@itu.int).

## Table of Contents

		Page
<b>1</b>	<b>Scope.....</b>	<b>342</b>
<b>2</b>	<b>References.....</b>	<b>342</b>
<b>3</b>	<b>Definitions.....</b>	<b>342</b>
	3.1 Terms defined elsewhere .....	342
	3.2 Terms defined in this document .....	343
<b>4</b>	<b>Abbreviations and acronyms .....</b>	<b>343</b>
<b>5</b>	<b>The architecture terminology .....</b>	<b>344</b>
	5.1 Architecture.....	344
	5.2 ICT Architecture.....	345
	5.3 ICT Architecture development methodology.....	346
	5.4 Smart Sustainable City ICT Architecture.....	346
	5.5 SSC ICT Architecture development methodology.....	347
	5.6 SSC ICT Architecture interfaces .....	348
<b>6</b>	<b>SSC ICT architecture.....</b>	<b>348</b>
	6.1 SSC ICT architecture framework.....	348
	6.1.1 Identification of needs.....	348
	6.1.2 Scope Identification.....	350
	6.1.3 Stakeholders Identification .....	351
	6.1.4 Architectural Principles .....	352
	6.1.5 Functional Requirements .....	354
	6.1.6 SSC ICT Architectural views .....	354
	6.2 SSC ICT Meta-Architecture .....	356
	6.3 SSC ICT architecture.....	359
	6.3.1 SSC ICT system's analysis and subsystems' definition.....	359
<b>7</b>	<b>Indicative SSC ICT architectural snapshots from different views .....</b>	<b>360</b>
	7.1.1 A software engineering view of the SSC ICT architecture.....	360
	7.1.2 A communications view of the SSC ICT architecture .....	361
	7.1.3 Modular SSC ICT architecture approach .....	365
<b>8</b>	<b>Guidelines for the SSC ICT architecture .....</b>	<b>368</b>
<b>9</b>	<b>Conclusions .....</b>	<b>375</b>
	<b>Appendix A.....</b>	<b>377</b>
	<b>Bibliography.....</b>	<b>380</b>



## Setting the framework for an ICT architecture of a smart sustainable city

### Executive Summary

These Technical Specifications describe the ICT architecture development framework of Smart Sustainable Cities and concludes on corresponding architecture views and guides.

These Technical Specifications are expected to become an ITU-T Recommendation.

### Keywords

Architecture, ICT Architecture, ICT Architecture Framework, Information Communication Technologies (ICT), Smart Sustainable Cities (SSC)

### Introduction

According to the Terms of Reference (ToR) of the Focus Group on Smart Sustainable Cities (FG-SSC), one of the objectives is to:

- Suggest future ITU-T study items and related actions within the scope of the ITU-T SG5 for example on:
  - Concepts, coverage, vision and use cases of smart and sustainable cities.
  - Characteristics and requirements of smart and sustainable cities.
  - Efficient services and network infrastructure of smart and sustainable cities, as well as its architectural framework from the environmental impact point of view.

In this document an architectural framework of SSC is proposed.



## 1 Scope

---

These Technical Specifications describe the ICT architecture development framework of a smart sustainable city and concludes on corresponding architecture views and guides.

It is applicable to ICT architecture for Smart Sustainable Cities.

## 2 References

---

[ITU-T TR SSC Def]	<i>Technical Report on smart sustainable cities: an analysis of definitions.</i>
[ITU-T TR SSC KPIs Def]	<i>Key performance indicators definitions for smart sustainable cities.</i>
[ITU T TR SSC-0113]	<i>Technical Report on “Setting the stage for stakeholders’ engagement in smart sustainable cities “Engaging stakeholders or smart sustainable cities”.</i>
[ITU-T TR SSC-0090]	<i>Technical Report on “Cybersecurity, data protection and cyber resilience in smart sustainable cities”.</i>
[ITU-T TR SSC-0097]	<i>Technical Report on “Overview of smart sustainable cities infrastructure”.</i>
[ITU-T TR SSC-0347]	<i>Technical Specifications for Multi-Service Infrastructure for smart sustainable cities in new-build areas.</i>
[ITU-T TR SSC overview]	<i>Technical Report on An overview of smart sustainable cities and the role of information and communication technologies.</i>
[ITU-T TR SSC building]	<i>FG-SSC deliverable, Technical Report on intelligent sustainable buildings for smart sustainable cities.</i>
[ITU-T TR SSC water]	<i>FG-SSC deliverable, Technical Report on Smart water management in cities.</i>
[ITU-T TR SSC management]	<i>FG-SSC deliverable, Technical Report on Integrated management for smart sustainable cities.</i>

## 3 Definitions

---

### 3.1 Terms defined elsewhere

These Technical Specifications use the following terms defined elsewhere:

**3.1.1 Smart sustainable cities** [ITU-T TR SSC Def]: A smart sustainable city is an innovative city that uses information and communication technologies (ICTs) and other means to improve quality of life, efficiency of urban operation and services, and competitiveness, while ensuring that it meets the

needs of present and future generations with respect to economic, social, environmental as well as cultural aspects.

## 3.2 Terms defined in this document

These Technical Specifications defines the following term:

**3.2.1 Architecture:** A definition of the structure, relationships, views, assumptions and rationale of a system.

**3.2.2 SSC ICT architecture:** The architecture of a smart sustainable city, which emphasizes on the role of the ICT (set of ICT components, which play individual roles within the system (i.e., authentication, data repositories, etc.) and all the components interact in order to establish the expected entire SSC role.

**3.2.3 Architecture framework:** The process that results in the definition of an architecture, consists of 3 steps: a) meta-architecture definition; b) architecture definition; and c) guides' definition.

## 4 Abbreviations and acronyms

---

These Technical Specification/Reports use the following abbreviations and acronyms:

BSI	British Standards Institute
EDA	Event Driven Architecture
FG-SSC	Focus Group on Smart Sustainable Cities
GPS	Global Positioning System
HART	Highway Addressable Remote Transducer Protocol
ICT	Information and Communication Technologies
IoT	Internet of Things
ISO	International Organization for Standardization
ITU	International Telecommunication Union
OAM & P & security	Operation, Administration, Maintenance and Provisioning, and Security
RFID	Radio Frequency Identity
SCADA	Supervisory Control and Data Acquisition
SOA	Service Oriented Architecture
SOE	State-Owned-Enterprise
SSC	Smart Sustainable Cities

UML	Unified Modeling Language
WPAN	Wireless Personal Area Network

## 5 The architecture terminology

---

### 5.1 Architecture

The term architecture is over-used in the context of ICTs and has been applied to aspects ranging from the structure of information to the delivery of technology, and even the technical management of an ICT solution [14; 15]. The term architecture is so wide ranging that all of these uses may indeed be valid. It may be worthwhile to draw on a familiar use for the term – the structuring of physical forms such as buildings. Architecture is defined as: *formation or construction as or as if as the result of a conscious act; a unifying or coherent form or structure; the art or science of building* [14; 15].

The key components of this definition concern something with a defined structure. The architecture of a building, for instance, is based on solid and coherent reasoning. The architect, the undertaker of the architecture, is charged with considering a wide range of aspects in the development of the architecture including, the client's will, site's requirements, legal and financial constraints, technology limitations, the building's users, and a host of other considerations that do not immediately appear to be directly related to the formation of the building. In essence, the architect is the conduit, through which all of the factors flow in realizing the final structure of the building. This relation between alternative stakeholders' perspectives and influencing forces, impacts the architecture formulation via a shared vision (as depicted in Figure 1).

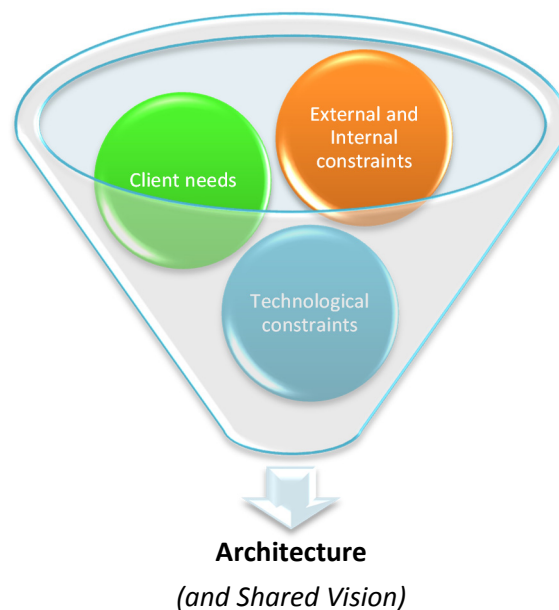


Figure 1 – Forces that impact architecture formulation

The above characteristics can result in the definition of the architecture [14]:

*A pragmatic, coherent structuring of a collection of components that through these factors supports the vision of the full "user" in an elegant way.*

An alternative would be [15]:

*A definition of the structure, relationships, views, assumptions and rationale of a system.*

## 5.2 ICT Architecture

The above analysis for the definition concerns a system (collection of components) and each of the individual components can represent corresponding architectural practices. For instance, an information system consists of components, which play individual roles within the system (i.e., authentication, data repositories, etc.) and they all interact to establish the entire system's role. As such, the term architecture offers the following features:

- It is used to define a single "system".
- It describes the functional aspects of the system.
- It concentrates on describing the structure of the system.
- It describes both the intra-system and inter-system relationships.
- It defines guidelines, policies, and principles that govern the system's design, development, and evolution over time.

Each system's component has to be defined with the same or alternative architectural practices (hardware, software, data flow, business flow, management, etc.), which can represent alternative architectural perspectives, which at high level synthesize the enterprise ICT architecture [14]:

- The *information architecture* deals with the structure and use of information within the organization, and the alignment of information with the organization's strategic, tactical, and operational needs.
- The *business systems architecture* structures the informational needs into a delineation of necessary business systems to meet those needs.
- The *technical architecture* defines the technical environment and infrastructure in which all information systems exist.
- The *software or application architecture* defines the structure of individual systems based on defined technology.

All the above information underlines that an architecture *defines a framework within which a system can be accurately specified and built at a specific time frame. It functionally defines what the elements of the system do and how the data and information is exchanged between them. An architecture is functionally oriented and not technology specific, which allows the architecture to remain effective over time. It defines "what" must be done, not "how" it will be implemented.*

### 5.3 ICT Architecture development methodology

According to the above findings, the definition of an architecture has a lot to do with information collection and understanding of all the stakeholders' needs, together with the limitations that come from the external environment and of the laws that impact the operation of system. As such, the following process is suggested to lead the architecture development (Figure 2):

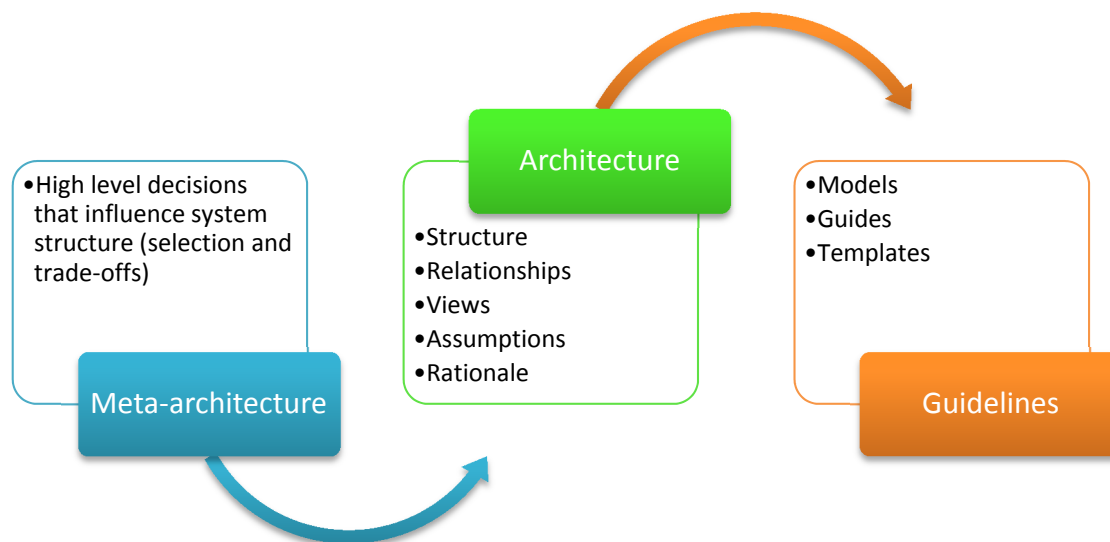


Figure 2 – ICT architecture development methodology

### 5.4 Smart Sustainable City ICT Architecture

This document emphasizes on the *technical architecture* from the architectural perspectives, which defines the platform on which the SSC organization (i.e., government, project coalition or business) builds and uses ICT in order to achieve in its defined mission [14]. To this end, the SSC architecture is the element, which:

- describes and defines the structure of the environment in which business systems are delivered;
- creates and maintains a set of core technology standards with which the SSC organization can measure technology projects;
- is an organizational capability – the people within (and outside) the ICT organization who provide strategic technical advice;
- is a means of resolving organizational technical issues;
- sets system (and hence software architecture), project, and corporate technology direction;
- establishes a reasoned approach for the integration of technology and business systems;
- establishes a framework for technology procurement decisions;
- both provides input to and is driven from the ICT planning process;
- allows the organization to control technology costs;
- develops a clear understanding of an organization's critical technical issues;

- provides a governance structure to support the ongoing health of the organization's technical environment;

As such, the SSC ICT architecture should be developed based on the complete architectures of its underlying systems in order to benefit from the potential integration and hence cost savings, of the underlying modules in the process of the combined city service provisioning management and control.

Accordingly, a smart sustainable city ICT Architecture document defines the types of components:

- Complex Systems (as a system of systems);
- Interconnections and Interfaces (between the Complex Systems); and
- Information Exchanges (between these Complex Systems).

## 5.5 SSC ICT Architecture development methodology

According to Figure 2, the methodology that this document follows concerns:

1. The definition of SSC ICT meta-architecture.
2. The definition of alternative SSC ICT architectures.
3. The definition of frameworks and patterns for the SSC ICT architecture.

The above process passes via the establishment of the following milestones (Figure 3):

1. *Identification of the needs:* This involves assessing the status quo of city services and processes. Examples from different regions should be described and analyzed in order to develop a rather generic or region-specific standardized architecture that can be found suitable for real implementation in different regions of the world.
2. *Stakeholders Identification and Needs Analysis:* This includes the roles and responsibilities of each stakeholder in developing, installing, procuring, operating, and maintaining the SSC elements is to be documented in addition to the functional and security related needs.
3. *Scope definition:* This includes the geographic boundaries and time frame that should be clearly stated at the onset of the process. The list of potential city service sectors, along with sector specific services should also be clearly identified and analyzed.
4. *Functional Requirements' definition:* This includes specifying a formal description of each subsystem belonging to a specific city service sector in order to identify the activities conducted by each subsystem.
5. *Subsystem and corresponding Interfaces' definition:* This describes how the different subsystems are connected and identifies any interfacing requirement.
6. *Dataflow Analysis:* Dataflow analysis between the different subsystems is conducted in this stage.
7. *Information Security and Privacy Requirements' definition:* Information security requirement is to be conducted based on the needs, functional, interface, and dataflow specifications of each subsystem.



8. *Systems Analysis and Final Design:* This involves analysis of the potential merge, deletion or addition of a system module to integrate different systems is to be conducted in this stage.

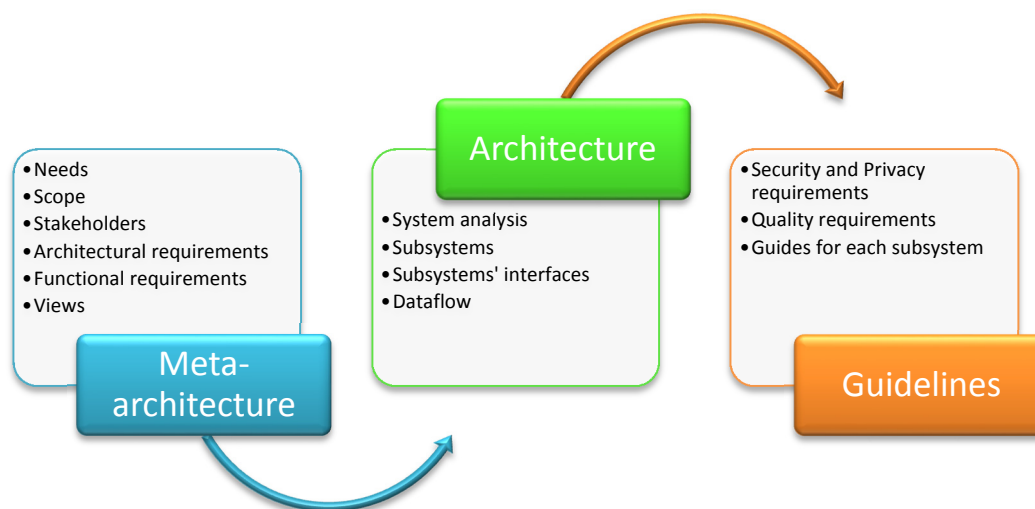


Figure 3 – SSC ICT architecture development methodology

## 5.6 SSC ICT Architecture interfaces

The interface is the median, which stands between the subsystems of one system [14]. There's no particular owner of an interface, neither intersystem contracts exist to describe the interfaces. Most interfaces execute typical batch jobs, while almost all require physical interventions to move generated files between subsystems. In the proposed SSC ICT architecture interfaces play the role to deliver information between discrete SSC ICT subsystems.

# 6 SSC ICT architecture

## 6.1 SSC ICT architecture framework

### 6.1.1 Identification of needs

The concept of Smart Sustainable Cities (SSC) has risen from the emerging urbanism phenomenon across the globe, according which the proportion of the international population that will live in cities will exceed 66% in 2050. The previously given SSC definition provides this document with the following characteristics for a smart sustainable city:

1. It concerns an urban space with innovative –not necessarily based on ICT- features. However, this document focuses on SSC architecture, where the ICT have a crucial role amongst the other innovative solutions and city facilities.

2. These innovation solutions address the following urban dimensions:
  - a. *People*: in terms of discovering and meeting today and future generations' requirements;
  - b. *Living*: by enhancing quality of life and social coherency, as well as efficiency regarding energy, food, water, etc.;
  - c. *Environment*: which includes protection, waste and emissions control against climate change;
  - d. *Governance*: in terms of ensuring urban utility and service availability;
  - e. *Economy*: in terms of sustainable growth and city competitiveness (attracting habitants, visitors and businesses).

Other approaches [1, 2] discuss about urban *mobility* in terms of transportation, which can be concerned part of the above *Living* dimension; *resilience* in terms of resistance against natural disasters, pandemics, terrorist attacks, accidents, etc. [3], which can be addressed by the above *environment* and *governance* SSC dimensions (Figure 4); *innovation* in terms of urban innovation [4], which is mainly disruptive, although the smart sustainable city becomes steadily a social innovation [5].

On the other hand, ITU Focus Group on SSC (FG-SSC) has delivered its document regarding Key Performance Indicators' (KPIs) definitions, which aligns to the United Nations Habitat dimensions (Table 1).

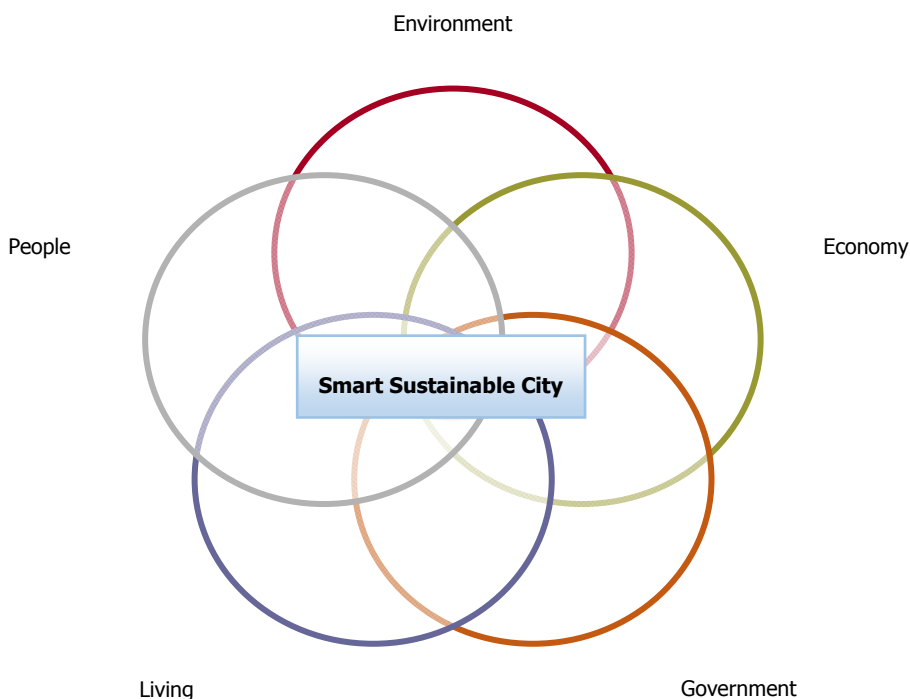
**Table 1 – ITU SSC key performance indicators (KPIs)**

SSC dimension
ICT
Environmental sustainability
Productivity
Quality of life
Equity and social inclusion
Physical infrastructure

The above characteristics illustrate the complex SSC nexus (shown Figure 1), where the five dimensions match the SSC KPIs (Table 2), matching was performed with the comparison of SSC KPIs with each of these dimensions and an important finding showing that complete matching is performed between *ICT*, *Quality-of-Life* and *Physical infrastructure* SSC KPIs with SSC dimensions, while the *Living* and *Government* SSC dimension matches to all SSC KPIs.

**Table 2 – Matching between SSC dimensions and SSC-KPIs**

SSC dimension \ SSC KPIs	People	Living	Government	Environment	Economy
ICT	X	X	X	X	X
Environmental sustainability		X		X	
Productivity		X	X		X
Quality of life	X	X	X	X	X
Equity and social inclusion	X	X	X	X	
Physical infrastructure	X	X	X	X	X



**Figure 4 – Smart Sustainable City dimensions fitting to the SSC and SSC-KPIs definition**

**6.1.2 Scope Identification**

A smart sustainable city ICT architecture has to comply with the particular requirements of all forms of cities, as well as with all alternative smart infrastructure types that have or are being followed by SSC.

According to the above findings, ICT plays crucial role for smart sustainable city development. More specifically, it has been depicted that ICT contributes to all the SSC dimensions (people, living, government, mobility, economy and environment), which is translated that the alternative ICT solutions, as they're expressed with SSC focus group's documents (i.e., IoT, telecommunication network, cloud computing, cybersecurity, etc.), play major role in SSC development.

SSC can be classified according to the smart infrastructure type and corresponding development stage [6] to the following categories:

- a) *Hard infrastructure* based: This category refers to city innovations, which target the efficiency and technological advancement of the city's hard infrastructure systems (i.e., transport, water, waste, energy).
- b) *Soft infrastructure* based: City innovations, which address the efficiency and technological advancement of the city's soft infrastructure and the people of the city (i.e., social and human capital; knowledge, inclusion, participation, social equity, etc.).

With regard to the city development stage they're classified as the following:

- a) *New cities* (Greenfield or 'cities from scratch' or 'planned cities'): They concern smart sustainable city projects where the entire city is being developed from ground zero, even urban planning addresses the above smart city dimensions and innovative solutions are embedded in the city. Various cases of this type are under development around the world ([FG SSC-0347, *Technical Specifications for Multi-Service Infrastructure for Smart Sustainable Cities in New-Build Areas*]).
- b) *Existing cities*: they concern SSC projects where the innovative solutions are installed in existing infrastructure. Representatives of this category concern all the cities, which develop various types of innovative solutions.
- c) *Smart plants*: they concern from-scratch projects, which are developed inside existing cities (i.e., new neighborhoods, new blocks or harbors, etc.) ([FG SSC-0347, *Technical Specifications for Multi-Service Infrastructure for Smart Sustainable Cities in New-Build Areas*]).

Finally, SSC ICT architecture has to comply with the all potential evolution that has been followed, such as from wireless and broadband cities, to recent ubiquitous and green cities [16], which demands flexibility from the architecture.

### 6.1.3 Stakeholders Identification

According to [ITU TR SSC-0113], a stakeholder is defined as any entity, an institution or an individual, that has an interest in SSC or that can significantly influence or be influenced by its deployment. As such, a set of stakeholders have been identified and concern:

- a. **Municipalities, City Council and city administration:** they are responsible for city management, and therefore they are the main promoters of SSC initiatives on each specific city.
- b. **National and regional governments:** they have remit on policies that can affect SSC implementation.

- c. **City services companies:** they would be implementing SSC solutions to increase city services efficiency.
- d. **Utility providers:** they are responsible for the deployment of some of the features of SSC such as smart grid or smart water management.
- e. **ICT Companies** (Telecom Operators, Start-ups, Software Companies): these are the providers of the global and integrated solutions, the city platforms, as well as the ICT infrastructure to support SSC deployment.
- f. **NGOs:** they are involved in all initiatives that can influence society and therefore are a stakeholder in SSC, especially on the axis of social sustainability.
- g. **International, Regional and Multilateral Organizations:** they include UN agencies and multilateral organizations. They can be promoters of initiatives towards human development, environmental sustainability and improvement of quality of life worldwide. They can offer funding opportunities, and are promoters of SSC initiatives.
- h. **Industry associations:** since industries are interested in the deployment of SSC, industry associations also work towards the success of this new model.
- i. **Academia, research organizations and specialized bodies:** they study SSC and associated trends, including its impacts and contributions to sustainable development.
- j. **Citizens and citizen organizations:** as users of cities, citizens are affected both directly and indirectly by SSC deployment.
- k. **Urban Planners:** their expertise is important to better understand how to include ICTs into medium and long term city planning, as well as to consider urban complexities.
- l. **Standardization bodies:** these are critical to ensure a common terminology and minimum characteristics of a SSC, as well as to define measurement methods to assess the performance and sustainability of city services based on ICT technologies.

It is obvious that the SSC ICT architecture has to comply with the alternative interests and perspectives that the above stakeholders' group have on a smart sustainable city.

#### 6.1.4 Architectural Principles

Architectural principles [14] concern guides that summarize the overall intent of both the IT strategic direction and the ensuing technical architecture resulting from this process. Resulting principles provide necessary vision for all ICT initiatives to follow within the SSC.

The previously identified context regarding needs, scope and stakeholders illustrate that there's a broad environment where the SSC ICT architecture has to be applied, which addresses:

- *Different geographic areas* (with various political, economic, technological, social and cultural characteristics);
- *Different technological artefacts* that potentially have been applied in the urban space (i.e., existing ICT solutions that have been developed by alternative stakeholders; public or private broadband networks, etc.);
- *Size and type of the city* (small versus global cities and capitals; new versus existing cities accordingly), which differentiate the size of SSC ICT impact and availability requirements, as well

as the capability to install various hard infrastructure (simple for new cities and blocks, compared to historical cities);

- *Different timeframes* within which the SSC ICT architecture is requested to operate (small communities change more slowly and their needs accordingly, compared to global cities).

The architectural principles that enable the SSC ICT architecture to align to the above characteristics concern:

- *Layered structure*: layered architecture has been proved to be applied in the mostly well managed SSC cases and can be applicable to most cases. Some layers have already introduced by the (*ITU FG-SSC 0097 specifications document on SSC infrastructure*) such as, the data and communication layer. However, exceptions have to be considered in cases where the SSC is not centrally and simultaneously developed, such as many European cases.
- *Interoperability*: interoperability needs to be ensured among heterogeneous and distributed systems in SSC for provision and consumption of a variety of information and services.
- *Scalability*: SSC ICT architecture has to be able to scale-up and down according to the size of city, the demand for services or business changes within the SSC.
- *Flexibility*: cutting-edge (i.e., cloud computing, IoT, etc.) and emerging technologies have be able to be adopted, while physical or virtual resources have to be rapidly and elastically adjusted to provide various types of SSC services.
- *Fault tolerant*: many quality attributes concern themselves with the availability of the architecture and its hosted componentry. Although fault tolerance is a rather strong phrase, it states the apex to which services and the architecture should aspire.
- *Availability, manageability and resilience*: service availability must be ensured according the SSC user demand; disaster recovery must be provided in various levels; manageability relates to operational concerns, in a sense that managing the architecture directly supports SSC ICT operations. Manageability -at a systems/subsystems level- has to be secured in order to allow normal operations of equipment, networks and applications, especially considering more and more operation process would be managed automatically.
- *Standards-based*: this principle has an identifiable tension with that of technology and vendor independence. Essentially, an organization endorses this principle to ensure contestability, replace ability, and longevity.
- *Technology and/or vendor independence*: SSC and mainly those that run under the State supervision and/or funding, require that architectures, solutions, or services be vendor-independent, to facilitate contestability, replacement, or simpler interoperability or integration. Of course, vendor independence may also compromise one's ability to negotiate preferential rates or treatment, and it is not unusual for (larger) organizations to nominate a preferred list of suppliers for certain services, allowing a degree of negotiation to occur to support cost containment.



### 6.1.5 Functional Requirements

Beyond the above architectural requirements, the ITU SSC focus groups has provided with specifications a lot of SSC functions, that the proposed SSC ICT architecture must offer:

- *Cybersecurity, data protection and cyber resilience (FG-SSC 0090)*: smart sustainable cities (SSC) are highly dependent on information and communication technologies (ICTs), including Internet of Things (IoT), radio frequency identification (RFID), and machine-to-machine (M2M). The advanced underlying infrastructure not only resolves the need for hyper-connectivity for smart sustainable city components and services, but also introduces higher levels of complexity and higher volumes of data. Cybersecurity, information protection and system resilience constitute political and governance issues at the forefront of new developments in this field.
- *Privacy*: privacy protection should be ensured during data transmission, aggregation, storage, and mining and processing.
- *Integrated Management*: integrated management for SSC (IMSSC) seeks to alleviate challenges in the SSC management through the incorporation of sensor web, model web, service interfaces, ICT products, Internet of things (IoT) as well as the cloud computing technologies in areas of city operations and management. Integration of such technologies is adapted to continuously resolve the problems in smart sustainable city management by encoding, fusing and sharing the information resources of the cities in a unified way. Such an integration has to be achieved by the proposed SSC ICT architecture, while the architecture itself has to establish integration between its sub-systems and/or components.
- *Hard infrastructure and environmental management*: the proposed SSC ICT architecture must meet SSC defined specifications, regarding SSC smart infrastructure and environmental management (smart water management, smart building, energy efficiency, etc.).
- *Service delivery*: the proposed SSC ICT architecture must deliver a specified –but scalable– service portfolio to its end-users. SSC ICT end users are all the city inhabitants (service demand side), as well as representatives from the SSC stakeholders (service supply side).
- *Information flow*: the information flow runs between SSC ICT end-users (demand and supply side and sensors) and SSC ICT subsystems, via the interfaces of each subsystem.

### 6.1.6 SSC ICT Architectural views

An individual system structure is a complex collection of components, building blocks, objects, hardware, networks, services, and non-functional requirements [14]. Representing these aspects in a unified architecture can be difficult. This is complicated by the fact that an eclectic array of skills is required to specify, develop, and assure such an architecture. This problem is multiplied for the SSC ICT architecture development, which represents an enterprise technical architecture. All components of the ICT environment are required to be modelled within the architecture to ensure that the end product (in this case, the SSC) is complete, logical, reasoned, and meets the predefined business requirements.

The complexity of such a representation limits its ability to be understood (a significant aspect of the architectural approach being the ability to support effective communication of the architecture) by those who created it and possibly not even then [14]. It affects the architecture's ability to be assessed and assured by subject matter experts in the organization, while it complicates the ability to deliver and maintain the architecture.

Architectural views reduce the effects of these issues and enable increased understanding, assessment, assurance, implementation and maintenance: *a view is a means of describing how an organization's specific needs are embodied in the architecture*. Views can be taken at any point through the architecture and there is no right way to divide the architecture. The most typical approaches include:

- *Functional views*: this view focuses on the functional aspects of the SSC, meaning what the SSC is intended to do.
- *Implementation views*: this view focuses on how the system is implemented and it is analysed in:
  - *Management view*: it concerns the SSC service provider point of view and determines the offered services, the supporting personnel, the manageability of system's subsystems and the decision of a centrally or distributed management method;
  - *Security view*: this view focuses on SSC requirements for cybersecurity;
  - *Builder's view*: this concerns the view of particular subsystems' developers;
  - *The data management view*: this view deals with the storage, retrieval, processing, archiving, and security of data; and
  - *The user view*: this view considers the usability aspects of the SSC ICT environment.
- *Physical views*: these views concentrate on the location, type, and power of the equipment and software:
  - *Computing view*: this view presents a number of different ways in which software and hardware components can be assembled into working systems.
  - *The communications view*: this view examines various ways of structuring communications facilities to simplify the SSC ICT planning and design. It examines the networking elements of the architecture in the light of geographic constraints, bandwidth requirements, and so on.
- *Business Process Domain View*: this view is a set of functional views aligned with the business process structure of the SSC. Business process domain views are used during architecture development as a means of verifying and demonstrating that the architecture being developed is addressing the SSC business requirements.
- *Software Engineering View*: it helps the architect to analyse the current methods used by the organization to develop software and aids in positioning architectural styles for future development.

## 6.2 SSC ICT Meta-Architecture

All the aforementioned specifications and requirements analyze the SSC in the following components, which must be integrated via the proposed SSC ICT architecture:

- **Soft infrastructure:** people, knowledge, communities
- **Hard infrastructure:** buildings, networks (transportation, telecommunications), utilities (water, energy, waste)
- **ICT-based innovative solutions:** both hardware and software solutions, which address the above hard and soft infrastructure
- **Other innovative solutions (beyond the ICT):** technological innovation that addresses smart city dimensions (i.e., open spaces, recycling system, smart materials, organizational innovations in government, etc.)
- **Natural environment:** concerns the physical landscape and the corresponding characteristics, where the city is installed (i.e., ground, forests, rivers, lakes, mountains, flora, etc.) and grounds the limitations for the hard ICT infrastructure installation.

An indicative n-tier architecture where physical, utility and ICT environments co-exist and interact, while people and businesses are also part of the SSC eco-system and interact with the smart city via SSC services is illustrated on (Figure A.1). In [7] various smart sustainable cities around the world were explored and an important outcome concerns that the architecture that is preferred by well-managed managed cases is the multi-tier (Table 1), which is applied in new, existing and smart planting cases, while it addresses both soft and hard infrastructure, while it considers natural environment and the evolving Internet-of-Things (IoT) in terms of sensor installation. Another architectural approach concerns the Service Oriented Architecture (SOA) (Figure A.2), which is proposed for existing cities, where innovation mainly focuses on soft infrastructure, as well as where IoT is utilized (Figure A.3). Finally, event-driven architecture (EDA) is proposed (Figure A.4), but it has not been applied yet. Table 1 shows that architecture is independent to the ICT solutions that is applied in the city, as well as independent to the smart city organization (Public organization, State-Owned-Enterprise (SOE), Project coalition or Private Company).

All the given information collected from literature and case studies suggest that the meta-architecture of the SSC must be multi-tier in order to be clear and sustainable, in terms of standardization and communication of these standards. According to the examined cases, this n-tier architecture must utilize hard and soft infrastructure and must contain the minimum following layers (Figure 5) from top to bottom:

**Layer 1) Natural Environment:** it concerns all the environmental features where the city is located (landscape, rivers, lakes, sea, forests, etc.).

**Layer 2) Hard Infrastructure (Non ICT-based):** it contains all the urban features, which have been installed by human activities and are necessary for city operation (buildings, roads, bridges, energy-water-waste utilities, etc.).

**Layer 3) Hard Infrastructure (ICT-based):** it concerns all smart hardware, with which SSC services are offered (i.e., datacenters, supercomputers and servers, networks, IoT, sensors, etc.)

**Layer 4) Services:** the SSC services, which are offered via the hard and soft infrastructure (i.e., smart safety, intelligent transportation, smart government, smart water management, etc.). These services have been analyzed and classified by various scholars [12] and are being focused by ITU FG-SSC too:

- Transportation services: parking management, logistics, trip optimization, intelligent transportation, accessibility and traffic management, etc.
- E-government services: administrative procedures, documents and open data, service applications (i.e., tax payments), e-deliberation and crowd sourcing, etc.
- E-Business services: typical intra-organization and inter-organization services, which are supported by the ICT (i.e., Enterprise Resource Planning (ERP) and Customer Relationship Management (CRM) functions, online procurement systems, e-banking systems, etc.).
- Safety and Emergency services: accident management (i.e., traffic accidents), crime prevention, public space monitoring, climate effects' changes, alerting and emergencies (i.e., in cases of kidnapping and natural disasters, etc.), etc.
- Smart health services: information sharing (i.e., environmental pollution data to people with diseases), tele-medicine, tele-care, health record management, etc.
- Tourism services: city guides, location based services, marketplaces, content sharing, etc.
- Education services: distance learning, digital content, digital libraries, ICT-based learning, ICT-literacy, etc.
- Smart Building: building performance optimization, remote monitoring and control, etc.
- Waste management services: monitoring, city waste management, emission control, recycling with the use of ICT, etc.
- Smart Energy services: artificial lighting, smart grids, energy efficiency's management, etc.
- Smart water services: quality measurement, water management, remote billing, etc.

**Layer 5) Soft Infrastructure:** individuals and groups of people living in the city, as well as applications, databases, software and data, with which the SSC services are realized.

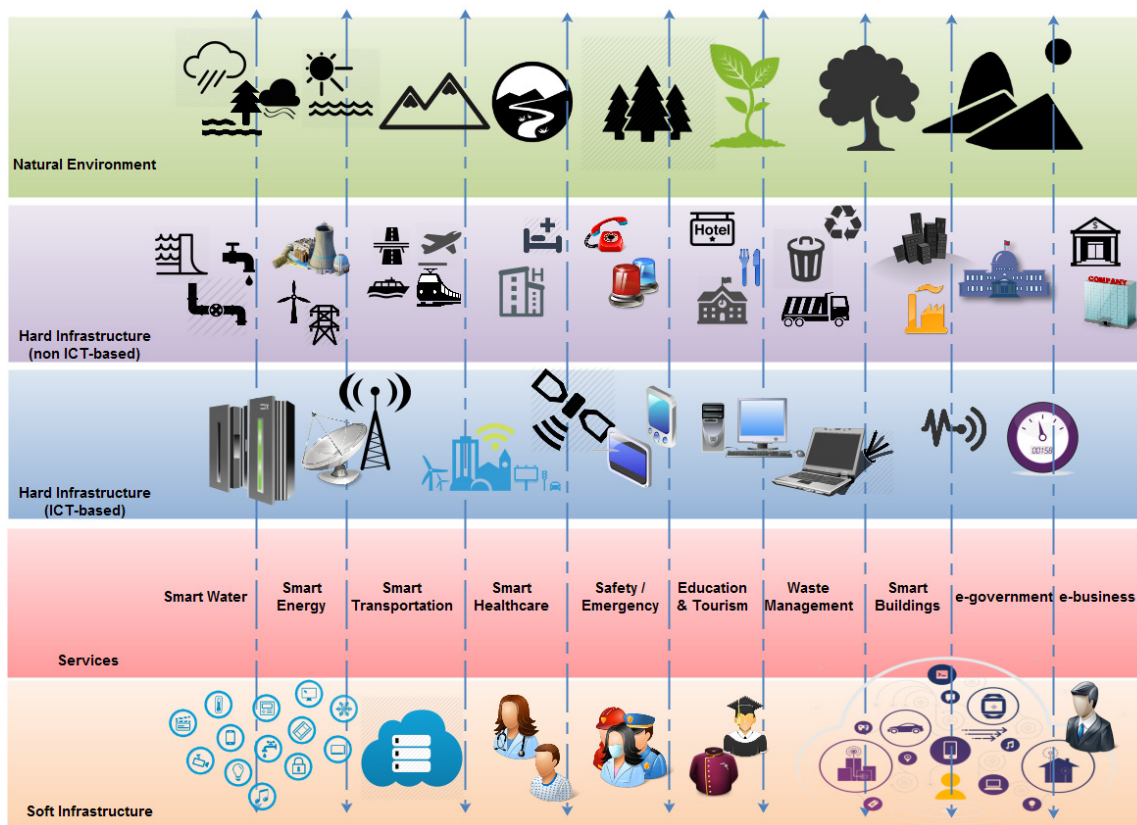


Figure 5 – Multi-tier SSC ICT meta-architecture

## 6.3 SSC ICT architecture

### 6.3.1 SSC ICT system's analysis and subsystems' definition

By its definition, the SSC ICT architecture aims to provide the following services to its end-users (inhabitants and stakeholders' representatives):

- Transportation services.
- E-government services.
- E-business services.
- Safety and Emergency services.
- Smart health services.
- Tourism services.
- Education services.
- Smart Building.
- Waste management services.
- Smart Energy services.
- Smart water services.

From the management view (service provider), all the above services structure the SSC service portfolio and a separate subsystem can be defined to offer each of them (Figure 6). Each subsystem requires both infrastructure and software to operate, it uses and produces data, while it transacts with end-users (demand and supply side) and with other subsystems via communication channels within the SSC.



Figure 6 – SSC ICT system's subsystems



Various transactions occur within the SSC ICT architecture and between SSC ICT end-users and the SSC ICT architecture subsystems. Indicatively, these transactions concern:

1. Information and service requests (demand side end-users);
2. Information and service delivery (supply side end-users and sub-systems);
3. Information and service requests (demand side subsystems);
4. Information and service delivery (supply side subsystems);
5. Information storage (demand side subsystems);
6. Information retrieval (supply side subsystems).

Individual interfaces stand around each subsystem and interconnects it with the others, while separate user interfaces offer service options to its end-users (demand and supply side) in order for a transaction to be performed.

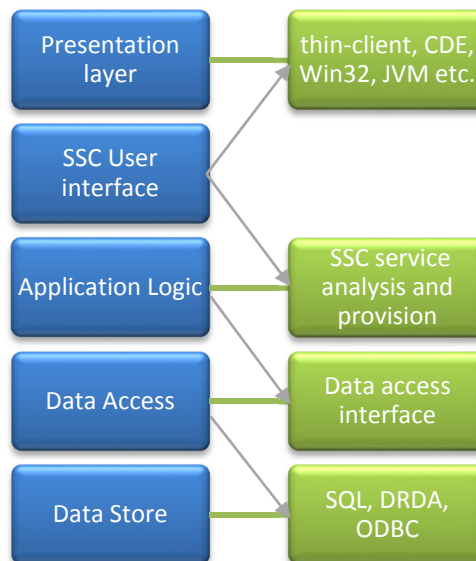
## **7 Indicative SSC ICT architectural snapshots from different views**

---

### **7.1.1 A software engineering view of the SSC ICT architecture**

According to [14] a multi-tier architecture can satisfy the SSC ICT architecture. More specifically, a 5-level approach introduces sufficient flexibility (Figure 7) due to following reasons:

- In a two-tier architecture, the user interface and business logic are tightly coupled while the data is kept independent. This allows the data to be independently maintained. The tight coupling of the user interface and business logic assure that they will work well together – for this problem in this domain. However, the tight coupling of the user interface and business logic dramatically increases maintainability risks while reducing flexibility and opportunities for reuse.
- A three-tier approach adds a tier that separates (an amount of) the business logic from the user interface. This in principle allows the business logic to be used with different user interfaces as well as with different data stores. With respect to the use of different user interfaces, users might want the same user interface but using different commercial off-the-shelf (COTS) presentation servers, for example, thin client, Java Virtual Machine (JVM) or Common Desktop Environment (CDE).
- Similarly, if the business logic is to be used with different data stores, then each data store must use the same data model ("data standardization"), or a mediation tier must be added above the data store ("data encapsulation").
- An additional level of flexibility can be achieved using a 5-tier scheme for software, extending the three-tier paradigm.



**Figure 7 – A multi-tier SSC ICT architecture from a software engineering point of view**

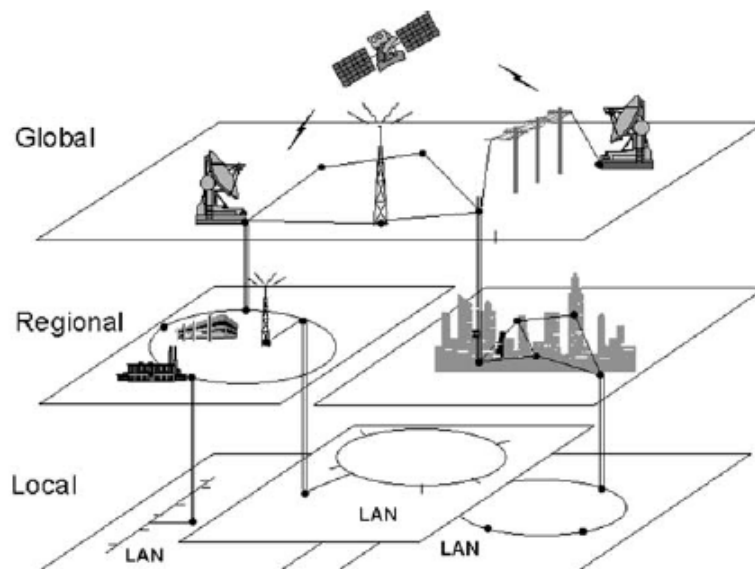
### 7.1.2 A communications view of the SSC ICT architecture

The communications view examines various ways of structuring communications facilities to simplify the SSC ICT planning and design. It examines the networking elements of the architecture in the light of geographic constraints, bandwidth requirements, and so on. Various alternatives can be followed to establish communications between SSC ICT architecture subsystems:

1. Cable networks (fiber-optic, coal-based networks within the city, etc.) installed in SSC;
2. Wireless networks (WiFi, WiMax, GSM, 4G mobile networks, etc.) installed in SSC;
3. Peer-to-Peer connections between SSC ICT architecture sub-systems;
4. Distributed Object Management (DOM);

All the above alternatives are organized in three groups regarding the network geographical range (Figure 8):

1. Global or wide area networks (i.e., across the SSC);
2. Regional area networks (i.e., neighborhoods of the SSC);
3. Local area networks (i.e., within a building or block of the SSC);



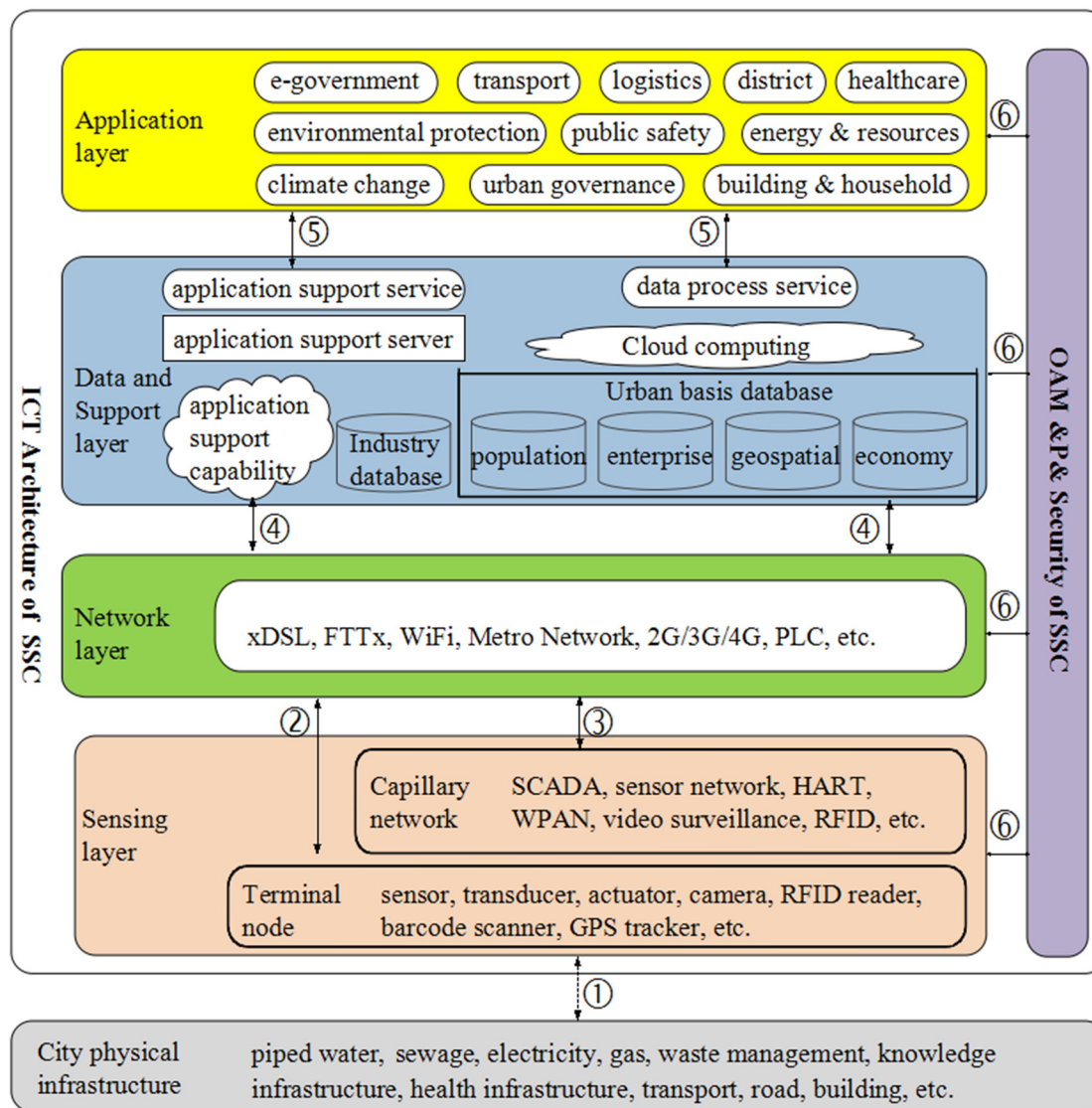
**Figure 8 – Groups of communication networks in a smart sustainable city [14]**

Such an approach, places communications and corresponding facilities and protocols at the core of the SSC ICT architecture and can multi-tier too.

Figure 9 depicts a corresponding SSC ICT architecture emphasizing on a physical perspective. On the other hand, figure 7 illustrates a corresponding SSC ICT architecture emphasizing on information flow. Both concern valid representations of the same architecture view, one closer to the language of infrastructure developer the second more in line with information system developer and they contain the following layers:

- *Sensing layer*: this consists of terminal node and capillary network. Terminals (sensor, transducer, actuator, camera, RFID reader, barcode symbols, GPS tracker, etc.) sense the physical world. They provide the superior "environment-detecting" ability and intelligence for monitoring and controlling the physical infrastructure within the city. The capillary network (including SCADA, sensor network, HART, WPAN, video surveillance, RFID, GPS related network, etc.) connects various terminals to network layer, providing ubiquitous and omnipotent information and data.
- *Network layer*: the network layer indicates various networks provided by telecommunication operators, as well as other metro networks provided by city stakeholders and/or enterprise private communication network. It is the "infobahn", the network layer data and support layer: the data and support layer makes the city "smarter", its main purpose is to ensure the support capabilities of various city-level applications and services. Data and support layer contains data center from industries, departments, enterprises, as well as the municipal dynamic data center and data warehouse, among others, established for the realization of data process and application support.
- *Application layer*: the application layer includes various applications that manage the SSC and deliver the SSC services.

- Operation, Administration, Maintenance and Provisioning, and Security (OAM & P & security) framework:** this provides the operation, administration, maintenance and provisioning, and security function for the ICT systems of SSC.



**Figure 9 – A multi-tier SSC ICT architecture from communications view, emphasizing on a physical perspective**

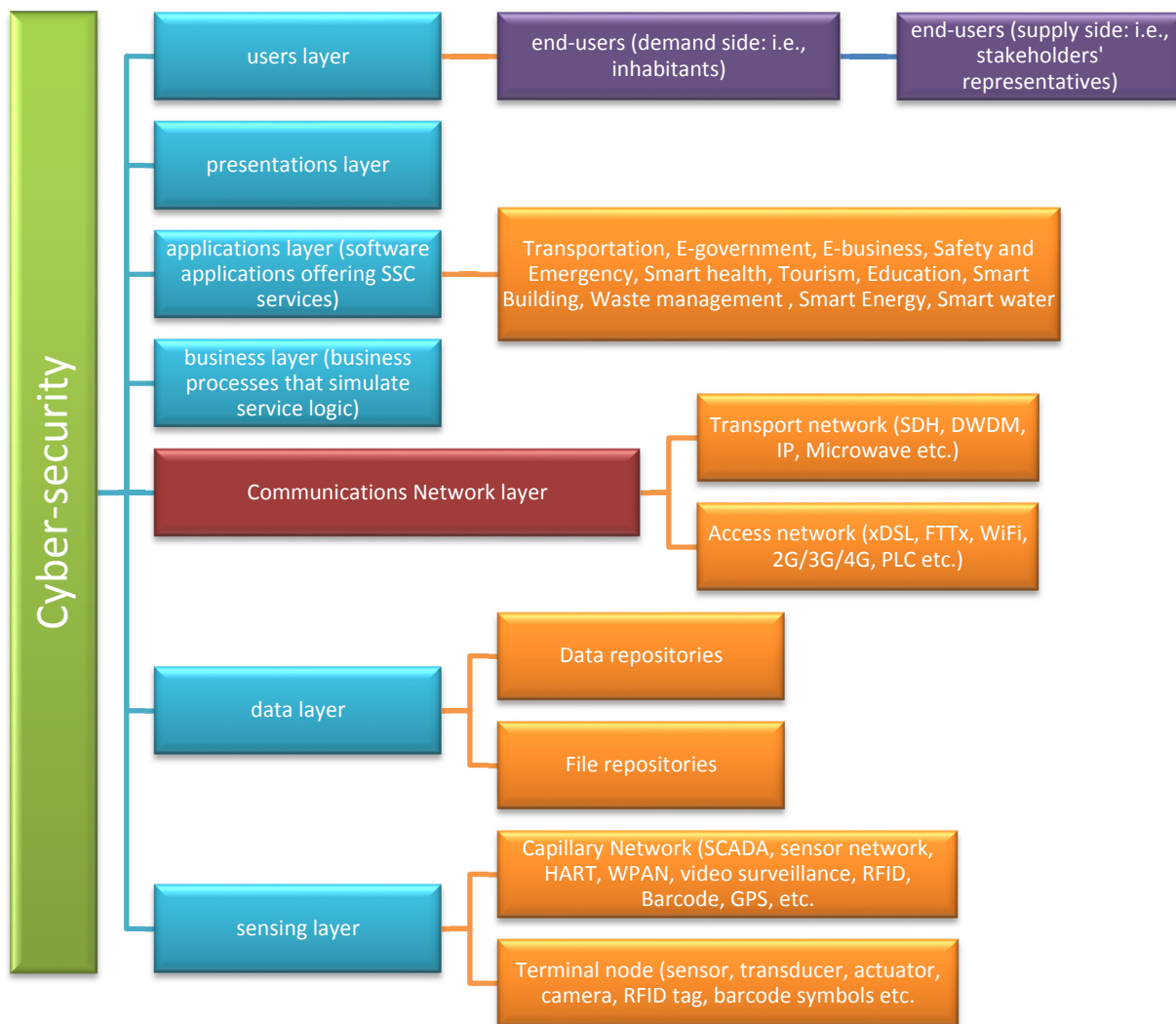
Figure 9 shows also, six interfaces between layers and OAM & P & security framework, marked with numbers in circles. These are places where communications and exchange of information between the layers, and OAM & P & security framework take place. They are the focal point of standards specifications and thus are called communication interface point. Overall functions at each of these reference points are listed below:

- Communication interface point 1:** this exists between the city physical infrastructure and sensing layer. It enables the terminals sense the physical world, i.e., exchange of information and control signals between terminal nodes in sensing layer and the physical infrastructure.

- Communication interface point 2: this exists between the terminal nodes in sensing layer and the network layer. In this case terminal nodes, directly or through net gates, access to the network layer without through capillary network.
- Communication interface point 3: this exists between the capillary network in sensing layer and the network layer. In this case capillary networks collect the sensing data, and connects to the communication networks.
- Communication interface point 4: this exists between the network layer and the data and support layer. It enables communications between data centers and lower layers for collecting various information through the communication networks.
- Communication interface point 5: this point exists between the data and support layer and the application layer. It enables data centers and/or application support functionalities providing information to corresponding city applications and services, and also enables integrated applications exchanging data via data centers and/or application support functionalities.
- Communication interface point 6: this exists between the OAM&P and security framework and the four layers. It enables the corresponding modules to exchange data flow and control flow and provide operation, administration, maintenance, provisioning and security function.

Figure 10 introduce the following tiers:

- *Users layer*: it organizes SSC service end-users into groups from both the demand and the supply sides;
- *Presentations layer*: it contains the user interfaces (web, Apps, voice commands, etc.), which stand between end-users and SSC services;
- *Business layer*: it consists of the business processes, which lie behind each SSC service execution.
- *Communications layer*: it contains the above mentioned networks, over which the SSC services are performed and transactions and data flow are realized;
- *Data layer*: it contains the data and file repositories, where data are created or retrieved;
- *Sensing layer*: this layer consists of terminal node and capillary network. The terminals (sensor, transducer, actuator, camera, RFID tag, barcode symbols etc.) sense the natural environment where the SSC is located and the corresponding hard infrastructure and utilities (water, transport etc.). It provides the superior 'environment-detecting' ability and intelligence for monitoring and controlling the physical infrastructure within the city. The capillary network connects various terminals to communication layer, or directly to data layer and/or application layer providing ubiquitous and omnipotent information and data.



**Figure 10 – A multi-tier SSC ICT architecture from communications view, emphasizing on an information flow perspective**

There are two ways for the information flow in the above architectural view:

1. The information flow starts from the sensing layer to the application layer across the communication layer and the data layer. This is the most typical mode of information flow in SSC, as it involves the whole four layers of SSC.
2. The information flow starts at the sensing layer and terminates at the data layer directly without across the communication layer, or start at the sensing layer end at the application layer directly without across the communication layer and the data layer.

### 7.1.3 Modular SSC ICT architecture approach

Module definition for the SSC ICT architecture is an extremely complex process and it has to consider both the city type and the architecture view. According to the previously given analysis, soft urban infrastructure (people, data and applications) is flexible and can easily extend and interconnect. Difficulties rise from requirements, which deal with hard infrastructure and environment. Various attempts illustrate modular smart city approaches [8; 9; 10]. Moreover, an interesting modular



architecture approach to smart city comes from [11] and can be utilized in the following analysis (Figure 11):

- 1) *Smart City Networking Infrastructure and Communications Protocol*: this module addresses the necessary infrastructure to deploy smart services and enhance living inside the city. Cities from scratch are based on innovations (both ICT-based and non ICT-based), which are embedded on city's hard infrastructure. For instance, a waste disposal, recycling and tele-heating factory can be installed and interconnected with buildings inside the city (Clever rubbish) [14]. Moreover, fiber-optic networks connect all local buildings with a central operating center, while smart buildings are accessible by their inhabitants via specific applications. In existing cities on the other hand, corresponding SSC cases integrate innovation with existing hard infrastructure with the IoT and basically with sensors that exchange data with specific applications. In such case, a corresponding modular analysis is depicted on. Moreover, protocol defines the codification for information interchange in SSC.
- 2) *Applications*: this module concerns all the smart applications, which are available inside the SSC. A well method for analyzing this module could be the classification of applications in the four SSC dimensions (Fig.1), including a separate group of mobility (i.e., intelligent transportation applications). It is analyzed in the following components:
  - a. *Mobility*: it concerns the applications that deal with transportation services (i.e., intelligent transportation, parking location and payments, traffic management, etc.).
  - b. *Government*: it represents applications regarding e-government services (i.e., information and document retrieval, certificate applications, government procedures, deliberation and consultation, etc.).
  - c. *Economy*: it contains applications in the business domain (i.e., e-business, business information systems, etc.).
  - d. *Environment*: this component utilizes applications for smart water and energy management, waste and emissions control, etc.
  - e. *Living*: application of this component address education, tourism, safety, health and care services.
- 3) *Business*: it addresses all business groups, which are available inside the SSC and utilize the above mentioned applications. Some particular business domains concern the industrial sector, finance, creative companies, rural production (i.e., agriculture, fisheries, etc.) and the service sector. This particular module addresses the following information management issues [11]:
  - a. User information for consumer behavior's detection.
  - b. Business intelligence for statistical and feasibility studies.
  - c. Industry information for market demand monitoring.
  - d. Business information for commercial and financial analysis.
  - e. Revenue Information for market cash flow and daily business activities' realization.
  - f. Circulation Information for emerged business cases' estimation.

- 4) *Management*: this module contains all rules and procedures for managing a smart sustainable city. The processes, people, resource, land and information are the primary elements and could be controlled centrally or individually with the appropriate set of standards. It is analyzed in the following components:
  - a. Information management: this includes information collection and dissemination across the SSC.
  - b. Process management: this addresses ICT management from a business transaction perspective in order to secure quality of service.
  - c. People management: this refers to human and workflow management in terms of a sequence of operations within the city, like a single organization (ISO1252 (2006)) and visualization (ISO/TR 16044 (2004)).
  - d. Land/spatial management: it represents urban and rural planning processes, as a means to secure sustainable land use.
  - e. Resource management: focuses on resource utilization and constraints' avoidance, in order to capitalize the steadily flowing municipal resources and facilities (i.e., machinery, tools, etc.).
- 5) *Data*: this module extends the approach from Al-Hader et al. (2009). Data is crucial in SSC and can be either used or produced, while they can be stored centrally or in a distributed manner (locally). It is analyzed in the following components:
  - a. People data: it concerns individual information, which is produced by SSC inhabitants and are mostly preserved with privacy issues.
  - b. Process data: it is produced during SSC service execution and routine transactions between machines and/or people.
  - c. Documents: these are mainly used or produced by government applications or within the business sectors. Documents can be also the basis of SSC operations (i.e., quality assurance, disaster recovery plans, etc.) and can be organized in digital libraries.
  - d. Geospatial: this is the data being utilized by Geographical Information Systems (GIS).
  - e. Business data: this data is used or created in the business module and in the smart economy applications.

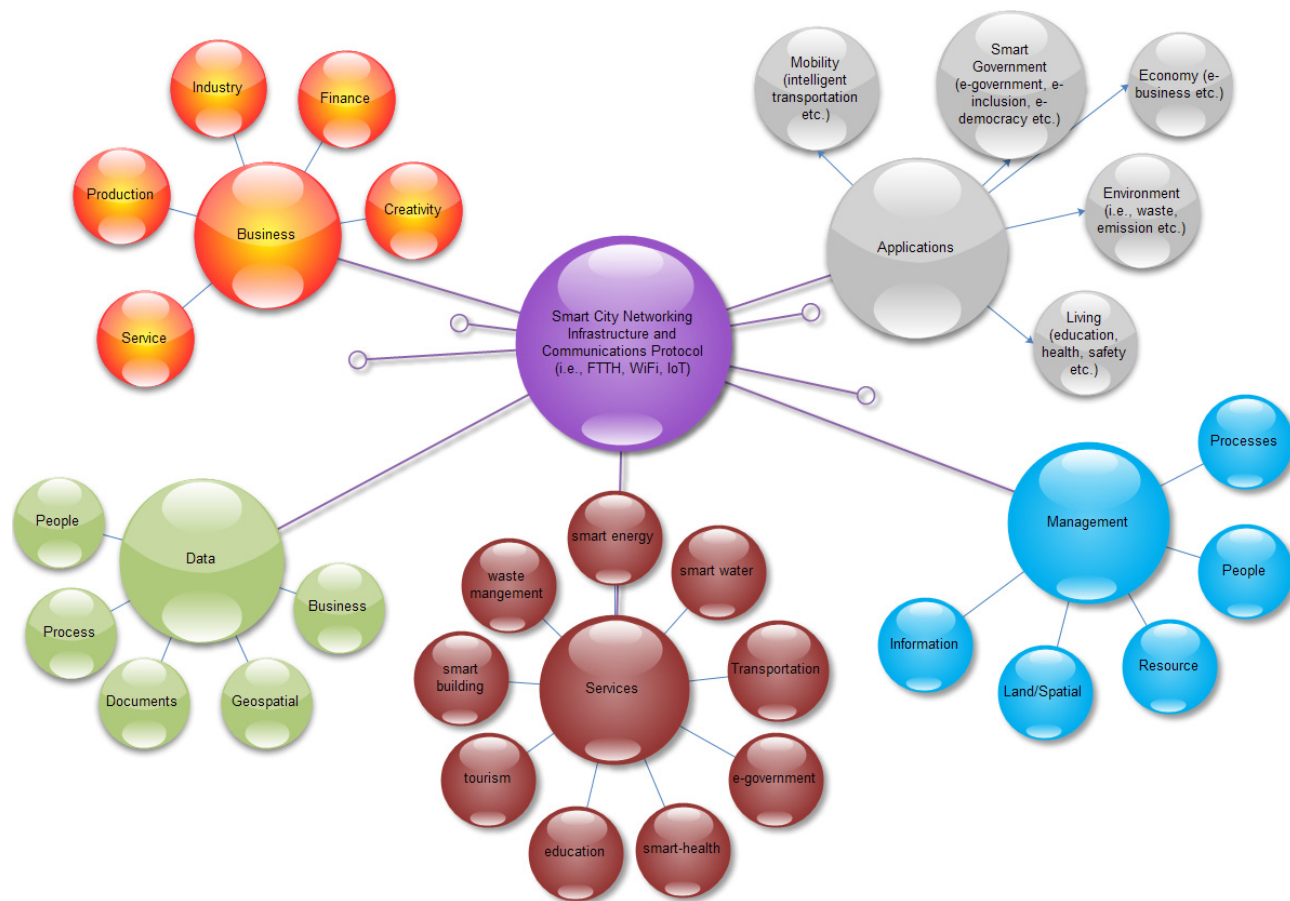


Figure 11 – Components analysis for a smart sustainable city

## 8 Guidelines for the SSC ICT architecture

These guidelines provide with specifications the SSC ICT architecture regarding the following aspects:

- Security and Privacy requirements: they are specified under the corresponding [ITU SSC-0090] Technical Report on Smart Sustainable City Cybersecurity, data protection and cyber resilience in smart sustainable cities
- Quality requirements: these are the minimum set of quality requirements have to be specified for each SSC ICT architecture's subsystem and for the overall architecture performance. Section 5.1.4 defined a set of principles for the SSC ICT architecture, some of which are totally quality-based (i.e., manageability, fault-tolerance, scalability, etc.)
- Guides for each subsystem: the above modular analysis returns the complex nexus of a SSC. However, most of the architecture components can be standardized and the assignment of standards to these components is presented in the following (Table 2):

ID	Module	Description	Applicability to KPI	Standard
<b>1.</b>	<b><i>SSC Networking Infrastructure</i></b>			
1.1	Wide Area Network (WAN)	Wired network deployed across the city.	ICT	IEEE 1703-2012, described also in [b-FG-SSC infrastructure]
1.2	Fiber to the Home (FTTH)	Fiber-optic network, which is being deployed in the city and interconnects each building	ICT	IEEE 802.3ah ITU G.983 ITU G.984
1.3	Metro WiFi network	Wireless broadband network with city coverage	ICT	IEEE 802.11x
1.4	WiMax	Wireless broadband network, covering extended geographic areas.	ICT	IEEE 802.16
1.5	Smart Building	ICT in building, which enables automation, control, safety and operation efficiency.	Physical infrastructure	Described in [b-FG-SSC infrastructure] and [b-FG-SSC building]
1.6	Internet-of-Things	Sensors that transform usual objects to intelligent ones.	ICT	N/A
1.7	Communications Protocol	Code and rules for interconnection and data exchange between sender and receiver.	ICT	<i>Depends on the communication nodes.</i>
1.8	Mobile communications	Mobile networks, provided by corresponding operators.	ICT	GSM UMTS (3GSM) IS-95 (CDMA one) IS-2000 (CDMA 2000) LTE
1.9	xDSL	Various DSL standards	ICT	Corresponding ITU specifications <sup>1</sup> like: G.991.1, G.992.1, G.992.2, G.994.1, G.995.1, G.996.1, G.997.1, G.993 ETSI standards <sup>2</sup>

<sup>1</sup> [https://www.itu.int/ITU-T/worksem/asna/presentations/Session\\_6/asna\\_0604\\_s6\\_p4\\_palm.pdf](https://www.itu.int/ITU-T/worksem/asna/presentations/Session_6/asna_0604_s6_p4_palm.pdf)

<sup>2</sup> <http://www.etsi.org/technologies-clusters/technologies/fixed-line-access/xdsl>

ID	Module	Description	Applicability to KPI	Standard
<b>2.</b>	<b>Applications</b>			
2.1	Mobility – Intelligent Transportation	Systems utilizing ICT to use available data to improve the safety, management and efficiency of terrestrial transport, and to reduce environmental impact	ICT Physical infrastructure Environmental sustainability	Described in [b-FG-SSC infrastructure]
2.2	Mobility – Smart Parking	Parking management systems and self-automated parking services	Physical infrastructure	N/A
2.3	Government – eGovernment	G2G, G2B, G2C services, which enable government transformation to a more efficient, transparent and accountable.	Equity and social inclusion	Interoperability frameworks and standards, such as OASIS interoperability guidelines <sup>3</sup> and e-GIF <sup>4</sup>
2.4	Government – eInclusion	ICT applications, which support the close of the digital divide and enhance accessibility.	Equity and social inclusion	Digital Agenda for Europe: Action Area: 2.2 Interoperability and standards "Improving ICT standard-setting" <sup>5</sup> Design-oriented standards such as WCAG 2.0 <sup>6</sup>
2.5	Government – eDemocracy	Applications for citizen engagement in policy and decision making, enable deliberation and enhance democracy.	Equity and social inclusion	N/A
2.6	Economy – eBusiness	ICT applications within business (i.e., e-banking, business information systems like ERP and CRM, e-commerce, electronic payments, etc.)	Productivity	i.e., OASIS recommendations for e-business <sup>7</sup>

<sup>3</sup> <https://www.oasis-open.org/policies-guidelines/interoperability-guidelines>

<sup>4</sup> <http://xml.coverpages.org/egif-UK.html>

<sup>5</sup> e-Inclusion activity <http://ec.europa.eu/einclusion>

<sup>6</sup> <http://www.w3.org/TR/WCAG20/>

<sup>7</sup> <https://www.oasis-open.org/news/pr/e-business-standards-developers-move-ahead-to-advance-collaboration-at-second-interoperabili>

ID	Module	Description	Applicability to KPI	Standard
2.7	Environment – water	Smart Water Management (SWM) promotes the sustainable consumption of water resources through coordinated water management, by the integration of ICTs products, solution and systems.	Environmental sustainability	[b-FG-SSC water]
2.8	Environment – energy	Smart energy concepts (i.e., smart grids) aim to ensure: i) reliability, ii) self-healing, iii) interactivity, iv) compatibility, v) energy saving, vi) optimal use of energy from renewable sources, vii) safety, and viii) minimum carbon footprint	Environmental sustainability	Described in [b-FG-SSC infrastructure]
2.9	Environment – waste and emission	Solutions such as improvement of transport thanks to the ICT infrastructure and its applications, and an improvement in energy efficiency, can reduce pollution and waste management.	Environmental sustainability	Described in [b-FG-SSC infrastructure]
2.10	Living – education	Besides the known contribution of ICT to education, both classroom-based and distance-learning, the influence of the SCC will mean that the citizen will be placed in the center of educational scenarios.	Quality of life	Described in [b-FG-SSC infrastructure] Sharable Content Object Reference Model (SCORM) for e-learning
2.11	Living – healthcare	Electronic Patient Records available to all medical services; public health professionals and clinicians to collaboratively access information in a secure way; tele-care and tele-medicine services.	Quality of life	Described in [b-FG-SSC infrastructure]
2.12	Living – safety/emergency	City safety system, Cloud-based large-scale data storage	Quality of life	Described in [b-FG-SSC infrastructure]



ID	Module	Description	Applicability to KPI	Standard
<b>3.</b>	<b><i>Business</i></b>			
3.1	All types of business sectors	Methodologies and techniques, which enable companies to effectively adopt ICT for business.	Productivity	Enterprise Architecture and Business Process Re-engineering
3.2	All types of business sectors	Personnel ICT skills' enhance.	Productivity	3tier ICT skills Pyramid <sup>8</sup> Digital Agenda for Europe: Internet Use, Digital Skills and Online Content <sup>9</sup>
<b>4.</b>	<b><i>Management</i></b>			
4.1	Process	Process mapping, standardization and management.	Productivity	Unified Modeling Language (UML) ISO 9001:2008 quality management ISO 1252 (2006) (for operations' virtualization) ISO/TR 16044 (2004) (virtual representation of actual work)
4.2	People	Human resource management techniques; community structuring and management schemas.	Quality of life, Productivity	ISO/NP 30400 Terminology ISO/CD 30405 Guidelines on recruitment ISO/NP TR 30406 Management by sustainable employability of staff ISO/AWI TS 30407 Cost-per-Hire ISO/CD 30408 Human governance ISO/NP 30409 Workforce planning

<sup>8</sup> Evans, N. (2002). Information Technology Jobs and Skill Standards. In Hawkins, Rudy and Wallace (Eds) *Technology Everywhere: A Campus Agenda for Educating and Managing Workers in the Digital Age*. John Wiley & Sons, Inc.

<sup>9</sup> <http://ec.europa.eu/digital-agenda/en/internet-use-digital-skills-and-online-content>

ID	Module	Description	Applicability to KPI	Standard
4.3	Resource	Local resource management methods (i.e., food, fleet, wood, etc.)	Environmental sustainability	N/A
4.4	Land	Urban and rural planning, land use and management methods.	Environmental sustainability ICT	Global Navigation Satellite System (GNSS) reference stations
4.5	Information	Information and records management methods.	ICT	ISO 19005-3:2012 ISO 19005-2:2011 ISO 19005-1:2005 For Document and records management BS ISO 15489:2001 Information and documentation. Records management.
<b>5.</b>	<b>Data</b>			
5.1	Data Management	Issues about data security; integration; cloud;	ICT	Described in [b-FG-SSC infrastructure]
5.2	Government open data	Glossary and rules for data opening in government organizations	ICT Equity and social inclusion	<sup>10</sup> Dublin Core <sup>11</sup> and ISO 11179 for data modeling ISO 15000 ebXML for web services
<b>6.</b>	<b>Services</b>			
6.1	Transportation	Parking management, logistics, trip optimization, intelligent transportation, accessibility and traffic management etc.	ICT, Physical infrastructure	<i>Defined above in the application module</i>
6.2	e-government	administrative procedures, documents and open data, service applications (i.e., tax payments), e-deliberation and crowd sourcing, etc.	Equity and social inclusion	<i>Defined above in the application module</i>
6.3	Safety and Emergency	accident management (i.e., traffic accidents), crime prevention, public space monitoring, climate effects' changes, alerting and emergencies (i.e., in cases of kidnapping and natural disasters, etc.), etc.	Quality of life	<i>Defined above in the application module</i>

<sup>10</sup> <http://www.opendatafoundation.org/?lvl1=work&lvl2=standards>

<sup>11</sup> <http://dublincore.org/>

ID	Module	Description	Applicability to KPI	Standard
6.4	Health and care	information sharing (i.e., environmental pollution data to people with diseases), tele-medicine, tele-care, health record management, etc.	Quality of life	<i>Defined above in the application module</i>
6.5	Education	distance learning, digital content, digital libraries, ICT-based learning, ICT-literacy, etc.	Quality of life	<i>Defined above in the application module</i>
6.6	Tourism	city guides, location based services, marketplaces, content sharing, etc.	Quality of life	ISO19133:2005 for location based services Other location based services' standards: KML, the application programming interface for Google Maps and Google Earth netCDF, science data encoding Open GeoSMS H.239 <sup>12</sup> standard for content sharing
6.7	Smart building	building performance optimization, remote monitoring and control, etc.	Quality of life	<i>Defined above in the SSC Networking Infrastructure</i>
6.8	Waste management	monitoring, city waste management, emission control, recycling with the use of ICT, etc.	Environmental sustainability	<i>Defined above in the application module</i>
6.9	Smart energy	artificial lighting, smart grids, energy efficiency's management, etc.	Environmental sustainability	<i>Defined above in the application module</i>
6.10	Smart water	quality measurement, water management, remote billing, etc.	Environmental sustainability	<i>Defined above in the application module</i>

<sup>12</sup> <http://www.itu.int/rec/T-REC-H.239/en>

## 9 Conclusions

---

These Technical Specifications collected a broad theoretical background regarding developing an SSC ICT architecture, which was strengthened with literature findings and experiences for various SSC cases in order to define a common SSC ICT architecture development process. This process returned a common SSC ICT meta-architecture, accompanied by a useful set of principles, functional requirements and guides for this architecture. However, it was concluded that no-unique physical SSC ICT architecture exists, but various alternatives are produced from the above process. Indicative architecture snapshots were depicted with regard of the software engineering and communications views respectively. Moreover, an analysis of the SSC ICT architecture in its subsystems and modules have been presented.

The content and supplementary information contained in these Technical Specifications allow the following general reflections:

- Multi-tier architecture secures SSC ICT good management. The proposed multi-tier meta-architecture covers hard and soft SSC facilities and delivers the required SSC services. The selected layers match completely to the SSC KPIs.
- Modular architecture secures flexibility and it is applicable to almost any SSC. The proposed modules focus on SSC synthesis and on ICT management. The selected modules with their components perform a perfect match to the SSC KPIs.

The illustrated architecture concerns a technical architecture, which can [14]:

- a) Enhance SSC ICT operation: better-defined structure and modularity in the ICT environment leads to a much more effective ICT operation:
  - Lower software development, support, and maintenance costs
  - More application portability
  - Improved interoperability and easier system and network management
  - A better ability to address critical SSC organization-wide issues such as security and privacy
  - Easier upgrade and exchange of system components
- b) Secure an improved return on existing investment and reduced risk for future investment: the structure of existing and planned systems is clearly defined, leading to:
  - Reduced complexity in ICT infrastructure
  - Maximum return on investment in existing ICT infrastructure
  - The flexibility to make, buy, or outsource ICT solutions
  - Reduced risk overall in new investment and the costs of ICT ownership
- c) Enable faster, simpler, and cheaper procurement: there is a clear strategy for future procurement and migration, with the result that:

- Buying decisions are simpler because the information governing procurement is readily available in a coherent plan
  - The procurement process is faster, maximizing procurement speed and flexibility without sacrificing architectural coherence
- d) Establish flexibility for business growth and restructuring: it is much easier to ensure access to integrated information across the SSC:
- Maximum flexibility for SSC organization growth and restructuring
  - Real savings when reengineering business processes following internal consolidations, mergers, and acquisitions
- e) Shorten time-to-market: an ICT infrastructure much better equipped to support the rapid deployment of mission-critical SSC applications leads to:
- Faster time-to-market for new SSC services.

## Appendix A

Table A.1 – Preferred architectures in various examined cases

Case	Findings	
	Architecture	Organization
European Smart Cities	Urban Intelligence Measurement System	Project (various European Cities)
Two cities in Netherlands	SOA	State-Owned-Enterprise (SOE) run by the municipality
52 cities	n-tier architecture (4 layers): <i>Network, Content, Intelligence, e-services</i>	Public Organization (i.e., Gdansk (Poland), Masdar (UAE)) Public Private Partnership (PPP) (i.e., Amsterdam (Netherlands)) Private Companies (Malaga (Spain), New Songdo (Korea))
Helsinki, Kyoto	n-tier architecture (3 layers): <i>information, interface, interaction</i>	State-Owned-Enterprise (SOE) run by the Municipality
Dubai	n-tier architecture (3 layers): <i>Infrastructure, data, application</i>	Public Organization (Government)
Trikala, Greece	n-tier architecture (6 layers): <i>data, infrastructure, interconnection, business, service and user</i>	State-Owned-Enterprise (SOE) run by the Municipality
Barcelona	n-tier architecture (4 layers): <i>code, nodes, infrastructure and environment</i>	SOE run by the Municipality in cooperation with the local university
Blacksburg Electronic Village	n-tier architecture (3 layers): infrastructure, content, community	PPP between Bell Atlantic Telecoms, Virginia Tech, Municipality
Amsterdam	n-tier architecture	PPP between Municipality and Liander grid Operator
Singapore	n-tier architecture (4 layers): ICT infrastructure, Cognitive infrastructure, Services, Customers	Public Organization



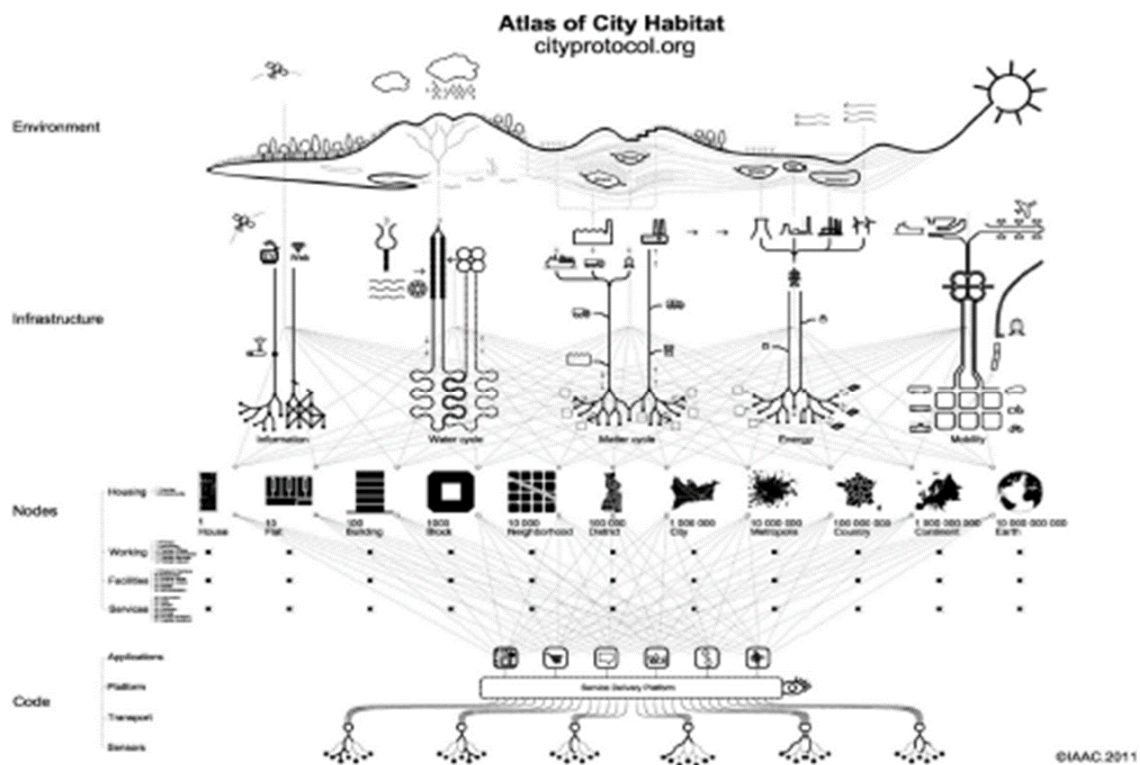


Figure A.1 – An indicative n-tier architecture (from Barcelona smart city)

- Different service sub-systems:
- City services: public services, local administration
  - Citizens: health, education, safety, Government services
  - Business: environment, burdens
  - Transport: cars, road, transportation, airports, harbors
  - Communication: broadband, wireless, phones, computers
  - Water: sanitation, freshwater supplies, seawater
  - Energy: oil, gas, renewable, nuclear

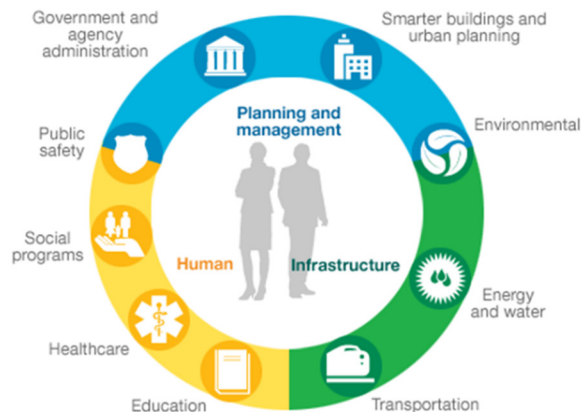


Figure A.2 – An indicative SOA [1]

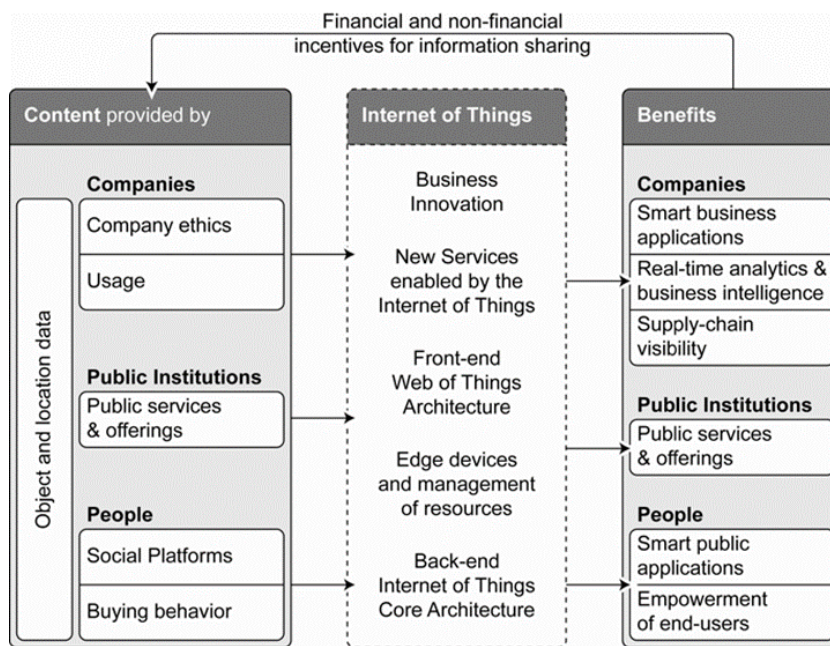


Figure A.3 – IoT architecture (content provided by city users and stakeholders is transformed by the IoT infrastructure and services to benefits to the same consumers)

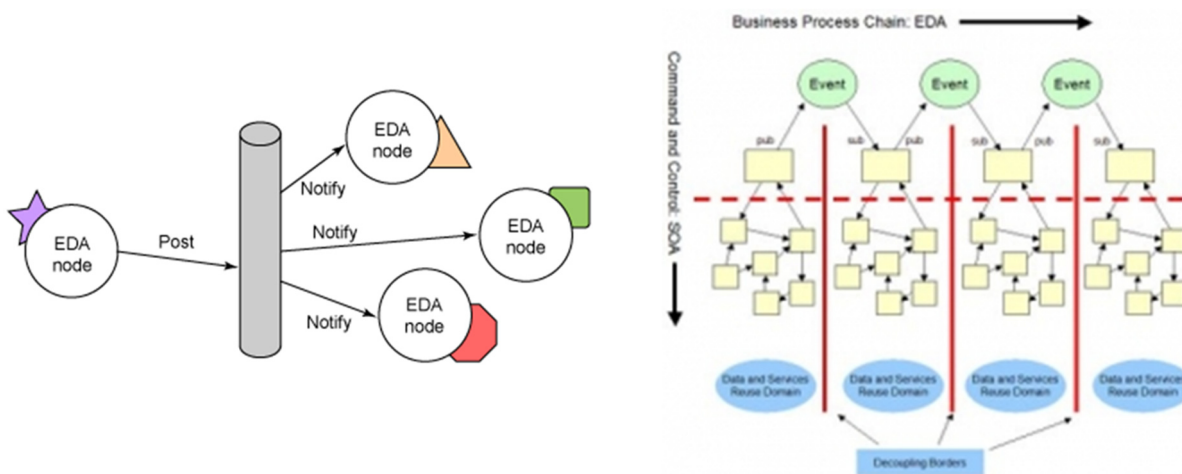


Figure A.4 – An indicative EDA (smart city as a system, where various events occur) [7]

## Bibliography

- [ITU-T TR SSC Def] FG-SSC deliverable, Technical Report on Smart sustainable cities: an analysis of definitions.
- [ITU-T TR SSC KPIs Def] FG-SSC deliverable, Technical Report on Key performance indicators definitions for smart sustainable cities.
- [ITU T TR SSC-0113] FG-SSC deliverable, Technical Report on setting the stage for stakeholders' engagement in smart sustainable cities.
- [ITU-T TR SSC-0090] FG-SSC deliverable, Technical Report on Cybersecurity, data protection and cyber resilience in smart sustainable cities.
- [ITU-T TR SSC-0097] FG-SSC deliverable, Technical Report on Overview of smart sustainable cities infrastructure.
- [ITU-T TR SSC-0347] FG-SSC deliverable, Technical Specifications for Multi-service infrastructure for smart sustainable cities in new-development areas.
- [ITU-T TR SSC overview] FG-SSC deliverable, Technical Report on setting the framework for an ICT architecture of a smart sustainable city.
- [ITU-T TR SSC building] FG-SSC deliverable, Technical Report on Intelligent sustainable buildings for smart sustainable cities.
- [ITU-T TR SSC water] FG-SSC deliverable, Technical Report on Smart water management in cities.
- [ITU-T TR SSC management] FG-SSC deliverable, Technical Report on Integrated management for smart sustainable cities.
- [1] IBM Institute for Business Value (2009). How smart is your city? Helping cities measure progress. Retrieved, February 6, 2015 from [http://www.ibm.com/smarterplanet/global/files/uk\\_en\\_uk\\_cities\\_ibm\\_sp\\_pov\\_smart\\_city.pdf](http://www.ibm.com/smarterplanet/global/files/uk_en_uk_cities_ibm_sp_pov_smart_city.pdf)
- [2] Giffinger, R., Fertner, C., Kramar, H., Meijers, E. and Pichler-Milanovic, N. (2008). *Smart Cities: Ranking of European medium-sized cities*. Retrieved, Feb. 6, 2015 from [http://www.smart-cities.eu/download/smart\\_cities\\_final\\_report.pdf](http://www.smart-cities.eu/download/smart_cities_final_report.pdf)
- [3] Pizzo, B. (2015). *Problematizing resilience: Implications for planning theory and practice*. *Cities*, 43, pp. 133-140.
- [4] Khare, A., Beckman, T., and Crouse, N. (2011). *Cities addressing climate change: Introducing a tripartite model for sustainable partnership*. *Sustainable Cities and Society*, 1, 227-235.
- [5] Dixon, T., Eames, M., Britnell, J., Watson, G.B., and Hunt, M. (2014). *Urban retrofitting: Identifying disruptive and sustaining technologies using performative and foresight techniques*. *Technological Forecasting & Social Change*, 89, pp. 131-144.

- [6] Angelidou, M. (2014). *Smart city policies: A spatial approach*. *Cities*, 41, S3-S11.
- [7] Anthopoulos, L., and Fitsilis, P. (2014). *Exploring Architectural and Organizational Features in Smart Cities*. In the Proceedings of the 16th International Conference on Advanced Communications Technology (ICACT2014), IEEE.
- [8] Cruickshank, P. (2011) *SCRAN: The Network*. *Journal of Urban Technology*, 18(2), pp. 83-97.
- [9] Kuk, G., and Janssen, M. (2011). *The Business Models and Information Architectures of Smart Cities*. *Journal of Urban Technology*, 18(2), pp. 39-52.
- [10] Kakarontzas, G., Anthopoulos, L., Chatzakou, D. and Vakali, A. (2014) "A Conceptual Enterprise Architecture Framework for Smart Cities: A Survey Based Approach". In the Proceedings of the ICE-B 2014 – International Conference on e-Business is part of the 11th International Joint Conference on e-Business and Telecommunications, Vienna, Austria; 28-30 August, 2014, SCITEPRESS.
- [11] Al-Hader, M., Rodzi, A., Sharif, A.R. and Ahmad, N. (2009). *Smart City Components Architecture*. In the Proceedings of International Conference on Computational Intelligence, Modelling and Simulation, IEEE.
- [12] Piro, G., Cianci, I., Grieco, L.A., Boggia, G., and Camarda, P. (2014). *Information centric services in smart cities*. *The Journal of Systems and Software*, 88, pp. 169-188.
- [13] Williamson, L. (2013). *Tomorrow's cities: Just how smart is Songdo?* [Online] Retrieved, March 20, 2015 from <http://www.bbc.com/news/technology-23757738>
- [14] Perks, C., and Beveridge, T. (2003). *Guide to enterprise IT architecture*. Springer-Verlag New York, Inc.
- [15] McGovern, J., Ambler, S.W., Stevens, M.E., Linn, J., Sharan, V., and Jo, E.K. (2003). *A Practical Guide to Enterprise Architecture*. Prentice Hall PTR.
- [16] Anthopoulos, L. and Fitsilis, P. (2014). Smart Cities and their Roles in City Competition: a Classification. *International Journal of Electronic Government Research (IJEGR)*, 10 (1), pp. 67-81.









# 3.3

## Multi-service infrastructure for smart sustainable cities in new- development areas

Technical Specifications



## Acknowledgements

These Technical Specifications were researched and written by Dave Faulkner (Climate Associates), Paolo Gemma (Huawei), Ziqin Sang (Fiberhome Technologies), N.S. Deepu (Ministry of Communications and Information Technology, India), R.M. Argarwal (Ministry of Communications and Information Technology, India), Flavio Cucchiatti (Telecom Italia), Leonidas Anthopoulos (Technological Education Institute of Thessaly, Greece), John Faulkner (Environment Agency, United Kingdom), Nilesh Kumar Purey (Gujarat International Finance Tec-City Co. Ltd., India), Satish Kamat (Lavasa Corporation Limited, India), Neeraj Mishra (Telecommunication Regulatory Authority, India) and Keith Dickerson (Climate Associates), as a contribution to ITU-T Focus Group on Smart Sustainable Cities (FG-SSC).

Additional information and materials relating to this report can be found at: [www.itu.int/itu-t/climatechange](http://www.itu.int/itu-t/climatechange). If you would like to provide any additional information, please contact Cristina Bueti at [tsbsg5@itu.int](mailto:tsbsg5@itu.int).

## Table of Contents

		<b>Page</b>
<b>1</b>	<b>Introduction .....</b>	<b>388</b>
<b>2</b>	<b>Scope.....</b>	<b>388</b>
<b>3</b>	<b>SSC Utility Service Requirements .....</b>	<b>389</b>
	3.1 Opportunities for Infrastructure Sharing in Central City Locations .....	393
	3.2 Growth, Maintenance and Upgrade in New Build Situations .....	409
	3.3 Lifecycle and obsolescence .....	410
<b>4</b>	<b>Smart Sustainable Building Utility Services .....</b>	<b>411</b>
	4.1 Opportunities for sharing risers (e.g., inside or alongside buildings) .....	411
	4.2 Smart Sustainable Building Service Requirements .....	411
<b>5</b>	<b>Opportunities for sharing infrastructure at street level .....</b>	<b>414</b>
<b>6</b>	<b>Opportunities for ICT to support other utilities.....</b>	<b>414</b>
<b>7</b>	<b>Opportunities for sharing the Application Platform.....</b>	<b>415</b>
	<b>Annex A – Glossary and list of abbreviations.....</b>	<b>417</b>
	<b>Appendix I – Bibliography .....</b>	<b>418</b>



## Multi-service infrastructure for smart sustainable cities in new-development areas

### Executive Summary

This document focuses on answering the question, “How should ICT infrastructure be planned for a new city given that it has to be both 'smart' and 'sustainable'?”.

The approach taken assumes that no infrastructure exists and the city or urban development area is to be built from new. A feature which is new for smart sustainable cities (SSCs) is the need for a sensor layer network and peripheral devices which may be directly connected to the internet, i.e., the internet of things (IoT).

To reduce whole life costs, this document explores the opportunities for infrastructure sharing from the outset. The primary concern for all types of installation is safety.

The location or collocation of ICT infrastructure is considered in urban corridors, trenches, urban tunnels and risers into buildings and rooms. Examples of web-based software platforms are provided which enable data sharing via application programming and other interface.

### Keywords

Urban Corridor, Utility Tunnel, Trench, sensor layer, application program interface.

## 1 Introduction

---

New cities are being planned in some countries where there is rapid growth in industrialisation. This leads populations to migrate from a rural to an urban environment to seek higher paid employment. This trend is expected to continue at least to year 2050. City planners therefore have the task of planning a city with a 'clean sheet of paper'. It is intended that this document will also be applicable to for suburban or city expansion which is being planned on a clean slate.

Until now city infrastructure, including ICT, has evolved to meet the needs of 'organic growth' whereby villages grew into towns and then into cities as populations have grown. Each new building or group of buildings was planned at a different time.

This document focuses on answering the question, "How should ICT infrastructure be planned for a new city given that it has to be both 'smart' and 'sustainable'?". The ICT infrastructure can then be planned and a set of technical requirements can be drawn up. After that, relevant specifications can be written, drawing upon the wealth of existing ICT specifications and standards.

The approach taken assumes that the city or development area of an existing city is to be built from new with no existing structures above or below ground. A feature which is new for smart sustainable cities (SSCs) is the need for a sensor layer network and peripheral devices which may be directly connected to the internet, i.e., the internet of things (IoT).

Sensors may be connected directly to a source of power and transmission such as an electricity cable or metallic pair. Sensors which require high bandwidth could be connected by optical fibre and wire for electricity. Sensors which use radio communication would need a source of power such as batteries.

Building and maintaining telecommunications and sensor layer networks is expensive, especially when installed on a reactive basis to meet emerging demand. To reduce costs, this document explores the opportunities for infrastructure sharing from the outset. The infrastructure could focus on a central location, such as the main railway station, city centre, or multiple clusters forming a city, where high capacity services are radiate towards the periphery of the city where individual homes, people, places and things require services. Shared infrastructure can save significant costs, especially when provision is made for maintenance, upgrade and growth over the lifecycle.

The primary concern for all types of installation is safety.

## 2 Scope

---

These Technical Specifications describe the various infrastructures for a smart sustainable city in a new-development area.

The designated infrastructure in this document includes: common physical infrastructure highlighting ICT, ducted and trenched infrastructure below ground, over ground common physical infrastructure, common risers in buildings, etc. The following issues are considered: safety, maintenance, lifecycle including possible obsolescence, flexibility points, scalability and growth. Examples are included of best practices for physical infrastructure including opportunities for sharing service paths below and above ground, such as conduits.

NOTE – Sharing wireless service infrastructure, such as lampposts and masts is mentioned in the FG-SSC report "EMF Considerations in Smart Sustainable Cities" [b-24].

It is not intended to address rehabilitation schemes such as upgrade of existing buildings. The focus is on establishing principles with outline rather than detailed dimensions.

This is one of a possible series of specifications to be addressed in Question 20 of ITU-T Study Group 5 (SG5).

### 3 *SSC Utility Service Requirements*

---

[b-1] identifies a number of services which utilize an urban corridor. The urban corridor is more commonly understood as a roadway or boulevard etc. The urban corridor is found in both new-build and existing cities and may be regarded as the conventional approach where each utility is installed separately in its own trench.

Underground services mentioned here and elsewhere include:

- Water distribution system
- Wastewater collection system
- Landscape irrigation water supply system
- Urban storm water drainage system
- Gas network medium and low pressure
- Power supply, including high voltage that supplies primary substations, medium voltage low voltage
- Telecommunication networks (e.g., fiber optic cables and twisted pair cables) and Community Antenna Television (CATV)
- Fiber optic networks including: Intelligent Transportation System, Traffic Control System, Closed Circuit TV, and Police
- District Heating/Cooling Network
- Power for public street lighting
- Oil pipeline for oil refining plant
- Solid waste collection is shown in [b-2] (vacuum pipes use suction of air to propel waste to a central waste processing unit-plasma gasification in this example). This is illustrated below as an example of a new service not present in most existing cities. An ICT management system is needed to support this.



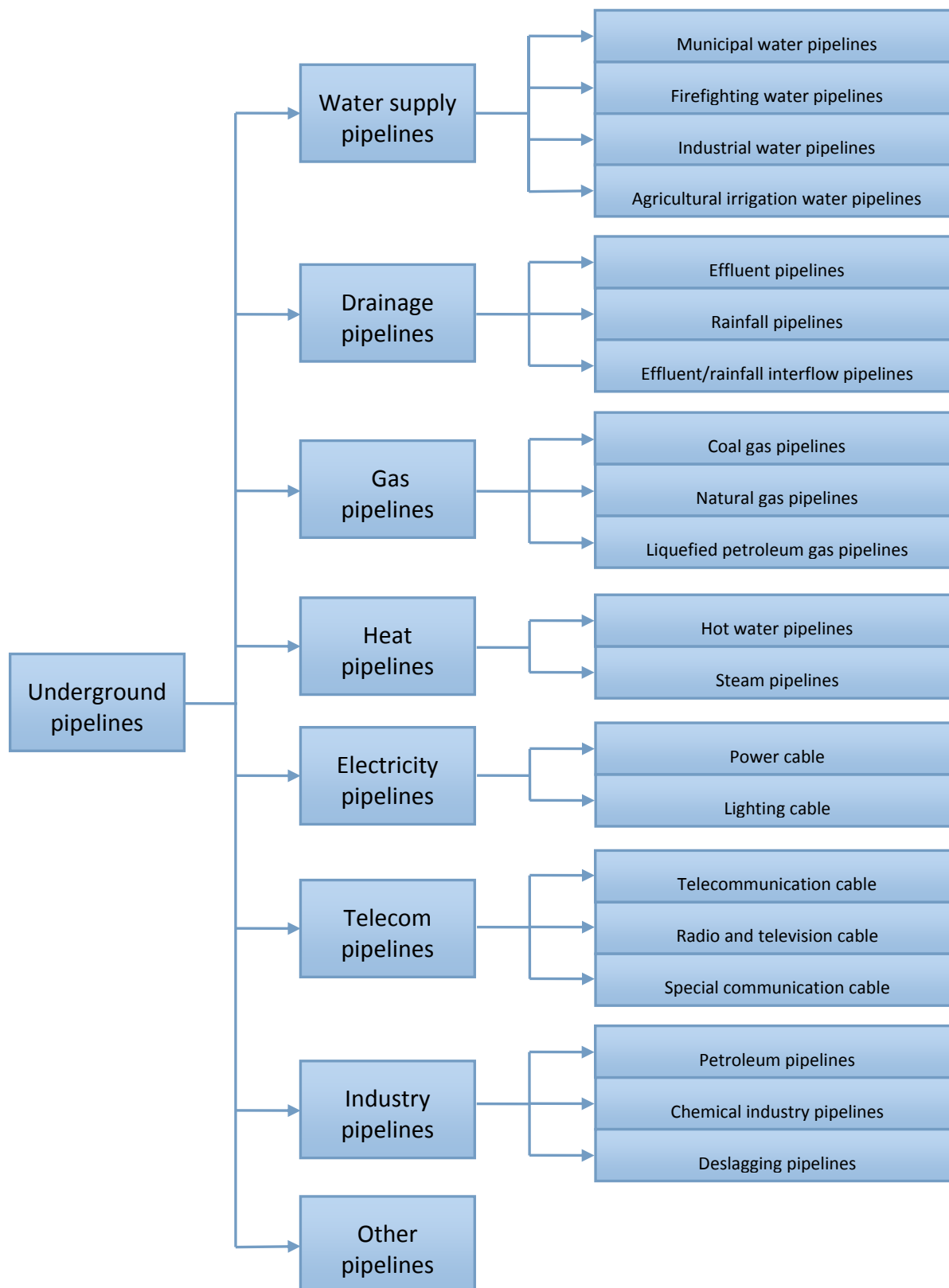


**Figure 1 – Solid waste collection**  
[Source: Nilesh Puery, b-2]

- Collective antennas for wireless systems [b-28]
- Ducted transport (e.g. pneumatic tubes [b-28] or automatic railway [b-10])

NOTE – Usually subway signalling systems (e.g., Leaky coaxial cable or rail transit wireless communication system) are not taken into consideration as these are most likely to be an independent underground service.

[b-26] classifies the underground pipelines into 8 categories according to the functions, i.e. water supply, drainage, gas, heat, electricity, telecommunication, industry and other pipelines (Figure 2).



**Figure 2 – Functional classification of underground pipelines**  
 [source: CJJ 61-2003, b-26]

[b-26] also lists the buildings and their affiliated facilities for various underground pipelines (Table 1).

**Table 1 – Buildings and their affiliated facilities for various underground pipelines**  
[source: CJJ 61-2003, b-26]

Pipeline type	Buildings	affiliations
Water supply	Water source well, water supply pump station, water tower, reservoir of clean water, purifying pond	Valve, water meter, hydrant, air evacuation valve, mud valve, preserved joint, valve pit
Drainage (rainfall, slops)	Drainage pumping station, drain trap, septic tank, purification structures, ground outlet for covered drain	Inspection pit, drop well, dry box with seal, flushing manhole, catch basin, inlet and outlet, water grate, effluent device
Gas, heat, industry pipelines	Pressure regulating house, gas station, boiler house, power station, gas tank, cooling tower	Expansion joint, exhaust/drain/effluent device, condensate well, various cellar wells, valve
Electricity	Power substation, power distribution room, cable examine hole, electricity tower/pole	Pole transformer, open ground transformer, various cellar wells, examine hole
Telecommunication	Transit exchange, control room, cable recondition hole, telecommunication tower/pole, repeater station	Connector box, distribution box, various cellar wells, examine hole

NOTE - Different countries may have other national standards or regulations for functional classification of underground pipelines as well as the buildings and their affiliated facilities.

Surface and above ground utilities.

In addition to the above, there are a number of surface services mentioned in [b-1] and elsewhere such as:

- Roadways
- Footpaths
- Tramways
- Street lighting
- Wireless networks
- Corridors for trees (e.g., to provide cooling and absorb polluting gases (NO<sub>x</sub> and CO<sub>2</sub>))
- Arrangement of solid waste collection facilities/bins.

Utility corridors could radiate out from a central location such as a central railway station or could terminate at a point near a river so that water flow by gravity can be easily exploited throughout the system.

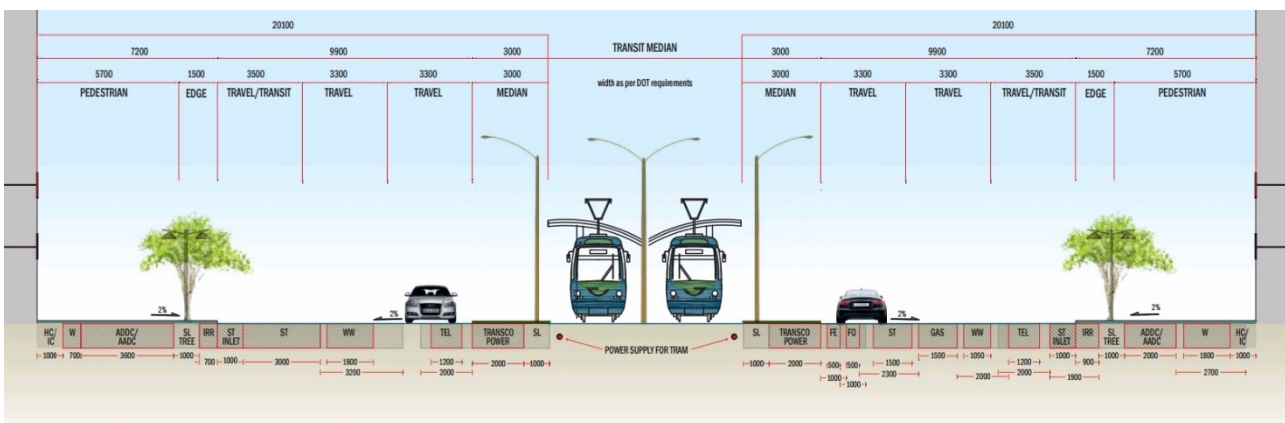
As far as is known underground and surface railway systems generally operate as a single service without sharing facilities with other utilities. Safety considerations may dictate such separation. However there are precedents such as tramways sharing services with roads in some cities such as Geneva. Thus there may be cost advantages when an underground railway is to be built directly under a road (e.g., London's Circle Line) to have common utility tunnels constructed alongside the railway but separated by a reinforced concrete wall.

### 3.1 Opportunities for Infrastructure Sharing in Central City Locations

Opportunities for infrastructure sharing occur when several services need to be provided along a common path to buildings or other locations such as where sensors or actuators are to be located.

#### 3.1.1 Urban Corridors with Direct Trenching

[b-1] shows a specification of a corridor with a metro (surface tramway) in the centre of the corridor. Lines and electric power are separate from the other utilities in the corridor. This is illustrated in [b-1, Figure 5:37].



**Figure 3 – Typical Utility Corridor Arrangement for Streets with Metro/Tram Lanes**  
 [Source: Abu Dhabi Utility Corridors Design Manual, b-1]

The operation and maintenance of the utilities will benefit from efficient and effective coordination. Inter-agency coordination during the installation and/or operation and maintenance activities will maximize the benefits and ensure the following [b-1]:

- Reduction in road maintenance costs [b-1]
- Provision of smoother roads with fewer closures for maintenance/rehabilitation activities [b-1]
- Provision of cost effective engineered solutions which are suitable for the local conditions [b-1]
- Promotion of consistent policies which eliminate disputes among stakeholders [b-1]
- Expediting project delivery and avoidance of project delays in the preliminary engineering, pre-construction and construction phases [b-1].

##### 3.1.1.1 Advantages of Trenching (direct burial) include:

- Initial costs may be lower because of the avoidance of the cost of the utility duct and subsequent installation of the cables into such duct
- Planning time needed among stakeholders is minimized
- Maintenance workers can focus their expertise (training) on one utility

- No central authority is needed to manage the stakeholders.

#### 3.1.1.2 Disadvantages of Trenching (direct burial) include:

- Maintenance costs are higher. Damage to one utility during repair or installation work on another utility is more likely because location information is not shared well among stakeholders
- Robust, precise location records for older utility trenches are often not provided or maintained, and older trench locations are often unknown. Low levels of collaboration among stakeholders is a limiting factor [b-3]
- Single-purpose trenches encourage a utility to follow a single-minded route to shorten runs and save initial installation costs for that particular utility. But uncoordinated routing encourages spatial chaos, using more space than if trenches were parallel [b-3]
- Access to a trenched network typically requires locating the utility network, cutting open the road or pavement surface, breaking open the concrete platform and excavating a trench, followed by reinstatement of the trench, concrete platform and road surface afterwards. (This is where most of the financial cost of network renewals and maintenance is incurred.) Road surfaces can be seriously damaged by frequent trenching, requiring more frequent resurfacing. In the process, pavement slabs are often broken and badly aligned. UK roads are subject to 5 million roadworks per year (mainly for utility works) [b-3]
- Maintenance of networks in trenches requires re-digging and restoring the trench and any roadbed above it. This is often performed in two steps. For example, a temporary layer of tarmac is laid so to allow the soil underneath to stabilize and then, after a few weeks, the road is re-dug, the soil is pressed again and the final layer of tarmac is put in place. Road users suffer repeated delays from roadworks, particularly in dense cities. Roadworks for trench adjustments also require large quantities of sand, aggregate, cement, tarmac and marking paint [b-3]
- Rural properties (e.g., SSC suburbs and periphery locations) are often denied access to services such as gas or cable telecom because the cost of new trench deployment cannot be economically justified independently of other networks. Therefore rural networks for electricity and telecoms are often above ground, with increased risk of disruption, even though there are usually local underground water and gas networks serving the same properties [b-3]
- Without common utility ducts, new types of networks require new trenches or independent ducts. Such expansions have already included cable telephone and television networks. Proposed local heat transfer systems and more localized, reconfigured power generation systems would also require new trenches [b-3]
- The high thermal conductivity of soil could cause overheating problems, e.g., from electricity cables.

#### 3.1.1.3 Example of trench sharing

The following extract from [b-4] provides an example of trench sharing practice in the UK where the trench is backfilled after the work is carried out. It also provides an example of cooperation among stakeholders to save cost.

"Trench sharing may be beneficial in reducing disruption to both vehicular and pedestrian traffic, as well as offering cost savings in construction methods and reinstatement liability for utilities. Trench sharing can also be useful in maximizing the limited available space in the highway.

- Wherever practical and appropriate trench sharing should be considered
- When trench sharing is an option it is essential that early consultation takes place with representatives from relevant authorities and all other interested parties

- Agreement on the positioning of apparatus within a shared trench together with the reinstatement specification should be made between all interested parties (including the relevant authority) as early as possible as part of the planning process
- A primary promoter should be identified to take overall responsibility as the agreed point of contact with the relevant authority. The primary promoter would normally excavate the trench and install its own apparatus. The secondary promoter/s would then install their apparatus in the same trench. The primary promoter would then backfill the trench and reinstate unless an alternative agreement has been made
- With regard to statutory noticing and permit requirements it is the responsibility of each party to individually notify their own works".

Further information about UK practice is given in [b-4]. This indicates that the local street authority has ultimate responsibility for coordination among stakeholders if difficulties arise. "A street authority should discuss any difficulties that the proposed works cause with the promoter and agree an acceptable way forward. However, safety concerns, urgency or lack of co-operation, may make it necessary for the street authority to use its powers of direction [b-5].

Similar coordination examples come from other Countries too. In Italy, the city managing body notifies each request for trenching to a list of all utilities and other parties potentially interested, requiring them to evaluate the opportunity to share the same path for the installation of their cables/ducts. This is done to minimize disruption to the traffic and to minimize costs. In some cities, after a road has been subject to trenching, it cannot be dug again before three years.

### 3.1.2 Utility Tunnel

A utility tunnel is considered an optimal solution to avoid underground crowding of utilities in narrow Right-of-Ways.

Sections 4 and 5 of ITU-T Recommendation L.11 [b-28] provide details on safety in utility tunnels. This Recommendation notes that

- many countries are interested in the joint use of tunnels and are aware of the advantages, disadvantages and specific dangers they hold;
- the rules governing this type of ducting vary significantly from country to country;
- the importance of the joint use of tunnels increases with increasing density of population and shrinking open spaces, i.e. in large towns.

Annex 1 of [b-28] provides an example Safety Plan against outside risks such as incoming gas and water and an example Safety Plan for risks inherent in tunnel ducts such as smoke and gas leakage

One of the major issues to be considered for the implementation of utility tunnels is that through all phases of planning, financing, construction and operation, the cooperation and agreement of all concerned parties should be ensured. The policies and practices of government, public and private utility providers and the various regulatory bodies should be considered.

Generally, pressure lines, such as water, irrigation, district cooling, as well as power and telecommunication cables, are installed within the utility tunnels. Gravity lines, such as wastewater and storm water drainage are normally avoided in tunnels due to difficulties in ensuring the minimum slopes necessary for gravity flow which might have implications for the tunnel grade/slope and depth causing deeper excavations and higher costs. In addition, gas lines are sometimes avoided in tunnels to reduce risks of explosion that may be caused by accidents and/or heat dissipation from power cables.



The following considerations should be accounted for in designing utility tunnels:

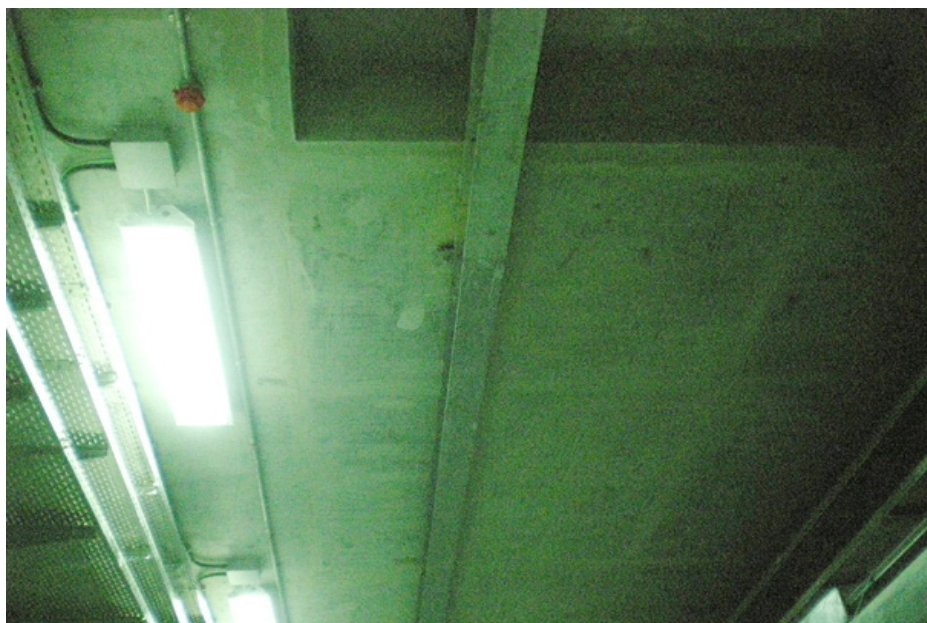
- Wet utilities should be separated from the dry utilities and installed in a separate compartment
- Tunnels should be designed as a walk-through system providing walkway access, and allowing for removal and replacement of valves, expansion joints etc.
- Tunnels may typically have a height of 1.9m or more. See Figures 15 and 17 which are from ITU-T [b-27]. The example shown in [b-1] is 4m high.
- Tunnels may typically have a width of 0.7 m or more. See Figures 15 and 17 which are from ITU-T [b-28]. The example shown in [b-1] is 4m wide.



**Figure 4 – Example of utility tunnel**  
**[Source: Abu Dhabi Utility Corridors Design Manual, b- 1]**

- Tunnels should be accessible through on-grade entrances with sloped hatches and sloping walkways
- Tunnels should be properly ventilated; ventilation shafts should be constructed at a minimum spacing of 50-75 m or as deemed necessary based on actual tunnel dimensions.

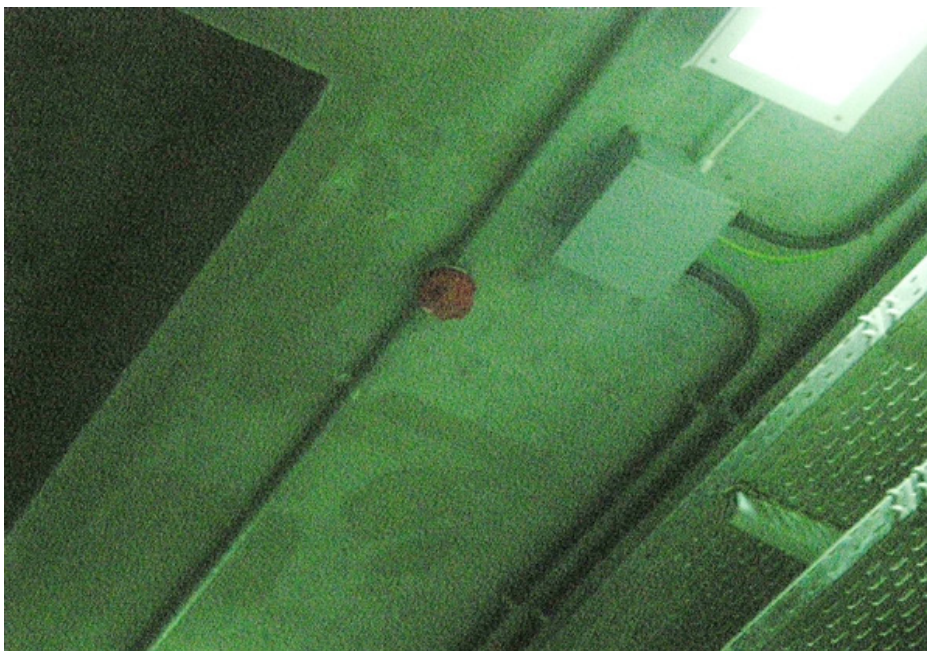
NOTE – Different countries may have other national standards or regulations.



**Figure 5 – Example of utility tunnel lighting**  
[Source: Abu Dhabi Utility Corridors Design Manual, b-1]

- Lighting should be designed to maintain a minimum light level of 150 LUX at the walk surface and be fitted with motion detectors and any necessary overrides for safety purposes.

NOTE – Different countries may have other national standards or regulations.



**Figure 6 – Example of utility tunnel fire detection/sprinkler system**  
[Source: Abu Dhabi Utility Corridors Design Manual, b-1]

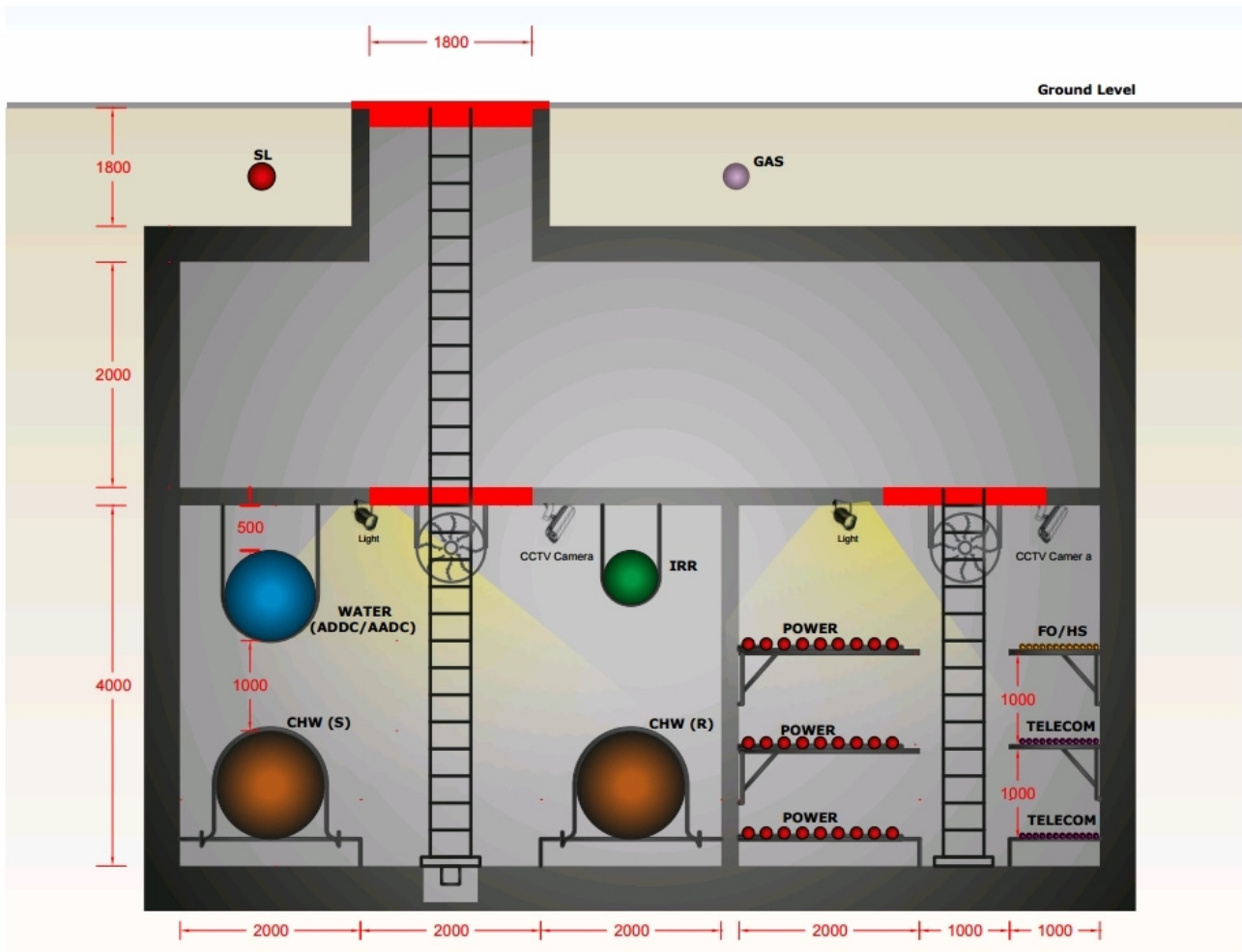


- Utility tunnels should be equipped with fire detection and alarm systems
- Firewalls may be required to isolate sections of the tunnel during a fire event, as per the local authority requirements
- Tunnels should include an emergency escape
- Wet utilities tunnels should include floor drains draining into a sump.
- Tunnels should include a closed-circuit TV system
- Tunnels should be equipped with a gantry for lifting heavy equipment, such as valves.

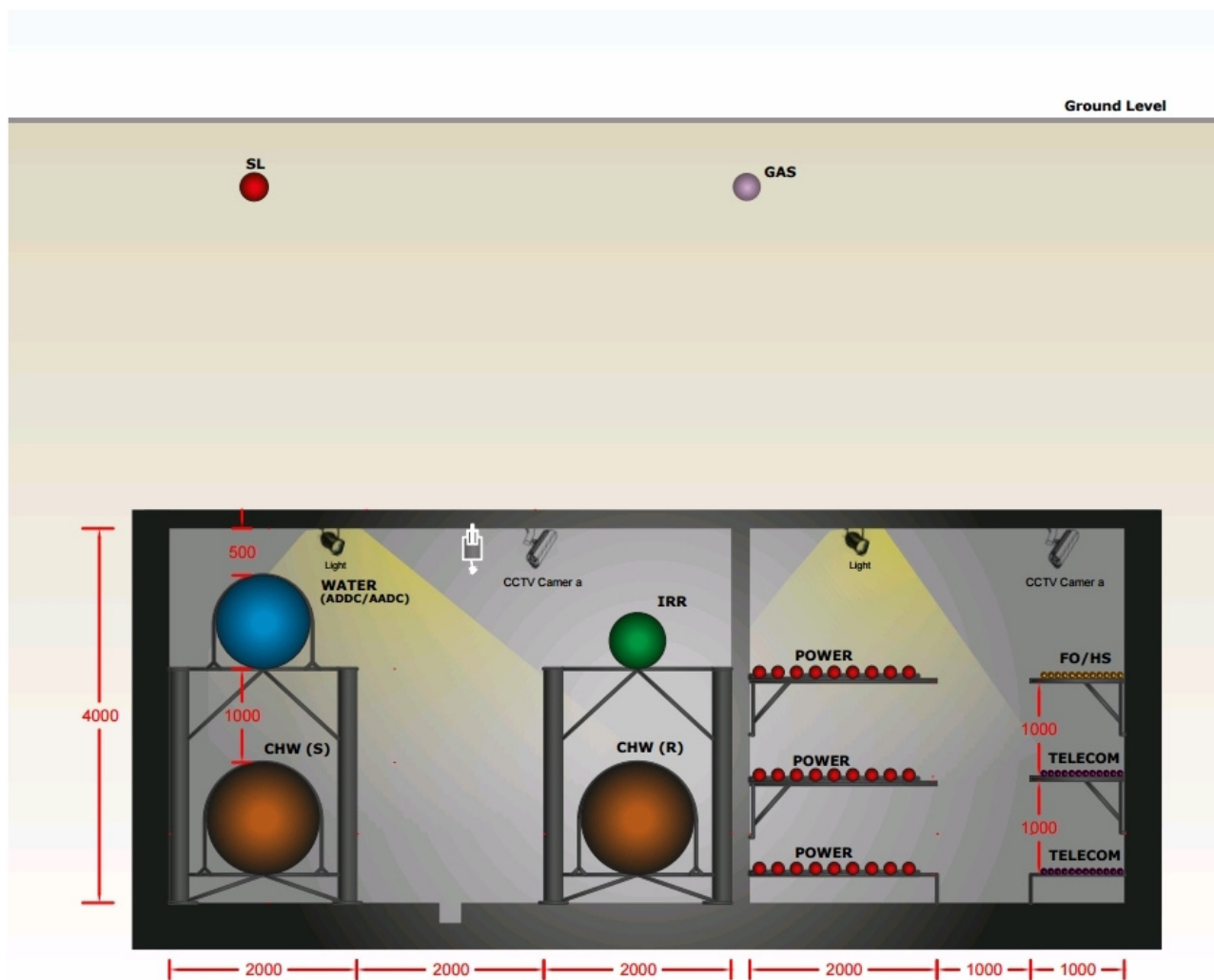


**Figure 7 – Example of heavy lifting equipment**  
**[Source: Abu Dhabi Utility Corridors Design Manual, b-1]**

- The utility tunnels should support their own weight as well as the weight of all installed equipment in (or on) the structures. The utility tunnels should support the weight and forces of all movable and active components and systems in (or on) the structures. For example, the steel cable trays should be able to carry the weight of the proposed number of cables
- Utility pipes and cables should be secured and fixed in their locations in the tunnel; for example, cables should be supported with cable cleats every 1.0 – 1.5 m
- Optical fibre and electrical cables need to be protected against rodents chewing the PVC. Some cables are specified to be rodent resistant.



**Figure 8 – Typical Arrangement of Utility Tunnel Showing Manhole**  
 [Source: Abu Dhabi Utility Corridors Design Manual, b-1]



**Figure 9 – Typical Arrangement of Utility Tunnel**  
 [Source: Abu Dhabi Utility Corridors Design Manual, b-1]

The following Figures illustrates some of the features supported by sensor network in the "GIFT city Gujarat", India. In August 2012, GIFT won the most prestigious award in the category of 'Best Industrial Development & Expansion' at the 'Infrastructure Investment Awards – 2012' organized by World Finance Group. GIFT Project was considered of world class value in terms of its potential for enabling economy growth in the region – through the relocation and centralization of India's financial and IT sectors and in providing the turn-key location for global financial & IT firms."



Figure 10 – Utility Tunnel, showing wet and dry sections  
[Source: Niles Puery b-2]



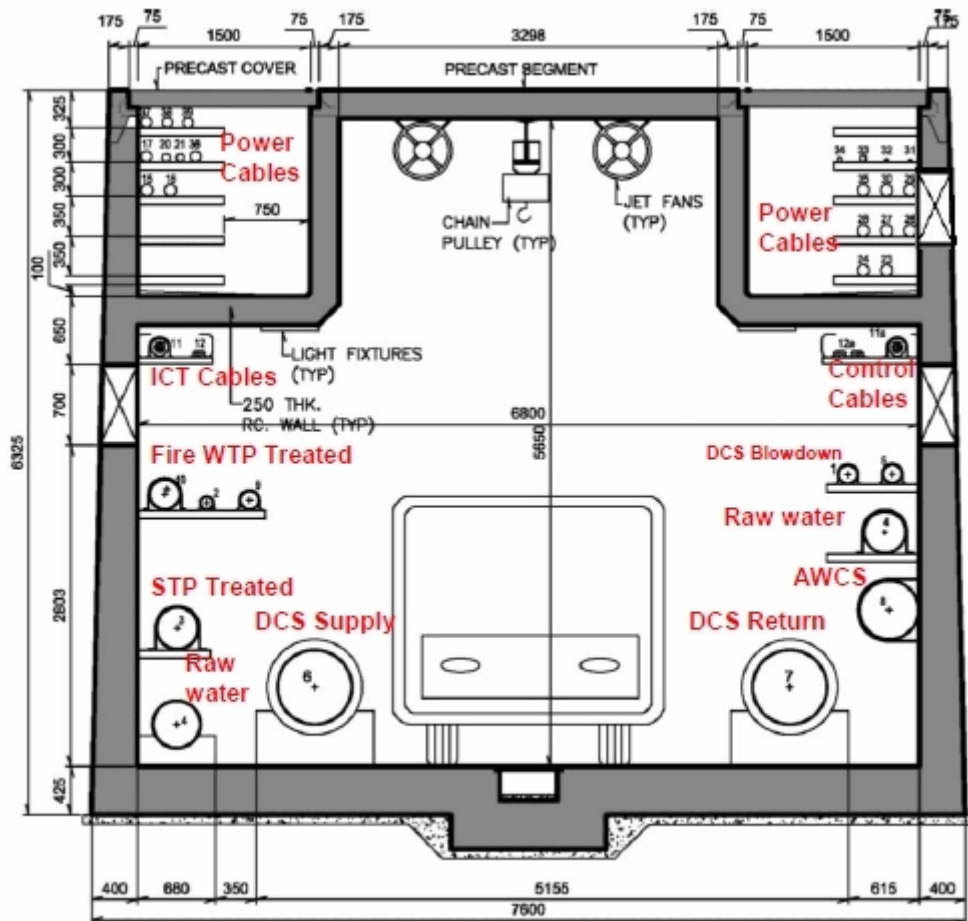


Figure 11 – Utility Tunnel, showing dimensions  
[Source: Nilesh Puery, b-2]



Figure 12 – Utility Tunnel, showing support brackets  
[Source: Nilesh Puery, b-2]



Figure 13 – Utility Tunnel, showing waste and water pipes  
[Source: Nilesh Puery, b-2]

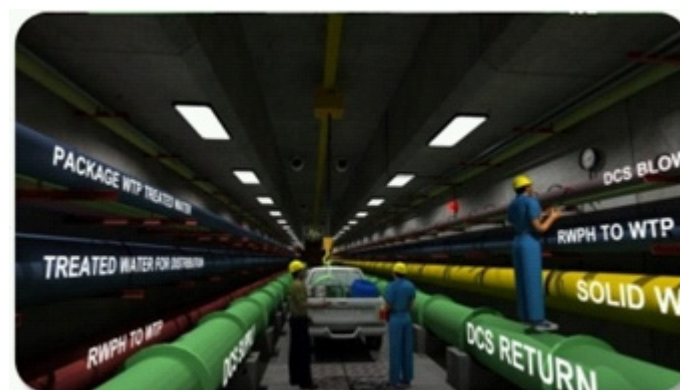
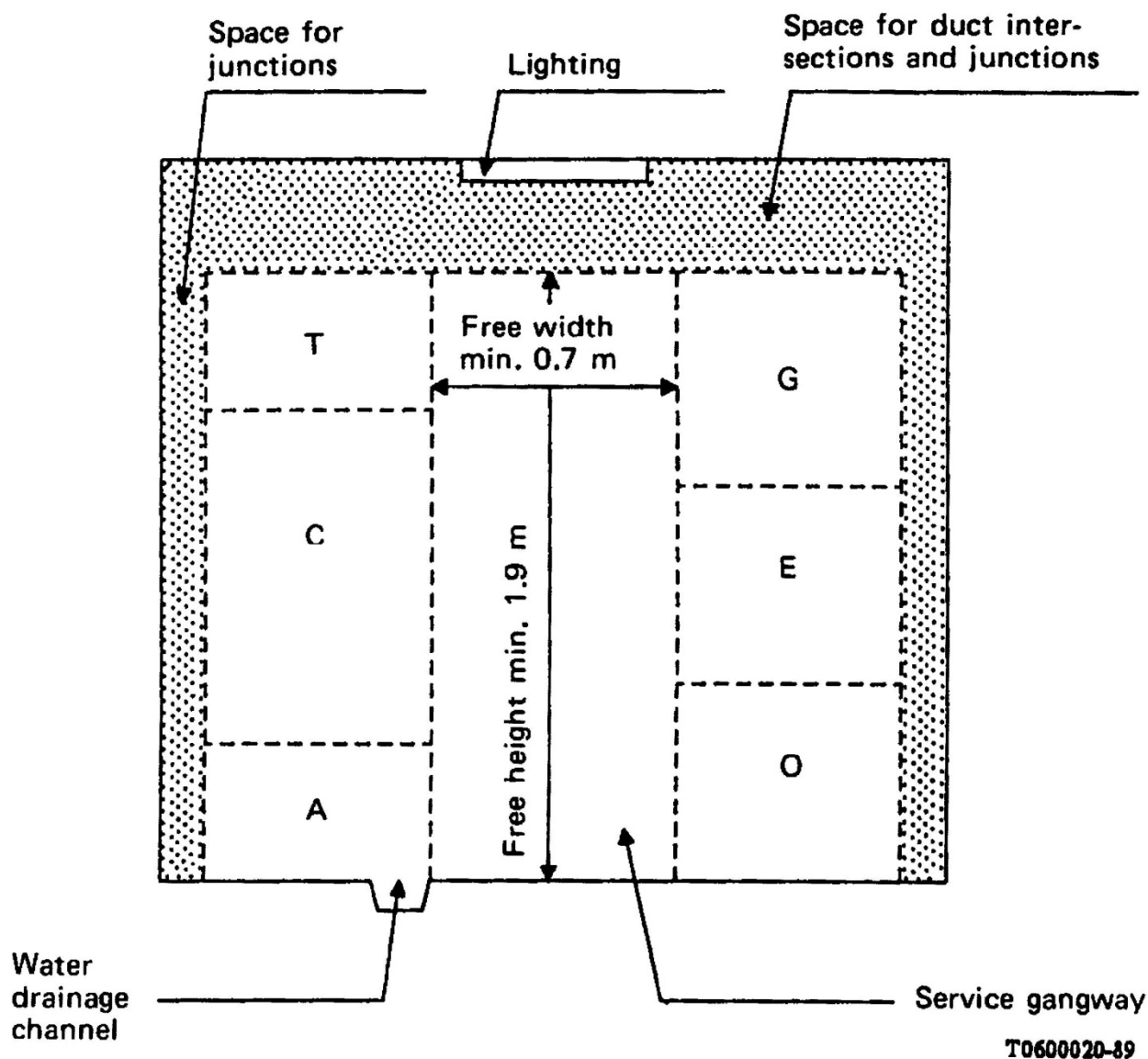


Figure 14 – Utility Tunnel, showing district cooling system solid waste and water pipes  
[Source: Nilesh Puery, b-2]



- T Telecommunication duct area (exposed cables)
- E Power duct area
- G Gas duct area
- O Water duct area
- C District heating duct area
- A Waste water duct area

Figure 15 – Example Utility Tunnel of Rectangular Cross section  
 [Source: ITU-T, b-28]

An example of a multi service tunnel construction standard which has been used in many cities in Italy [b-29] is shown below. This standard considers the possibility of coexistence in the utility tunnel of the following services: distribution networks of aqueducts; electricity distribution grids; electrical networks for public lighting systems and systems for traffic lights; telecommunications networks (telephone, data transmission, cable TV, etc.) and district heating networks.

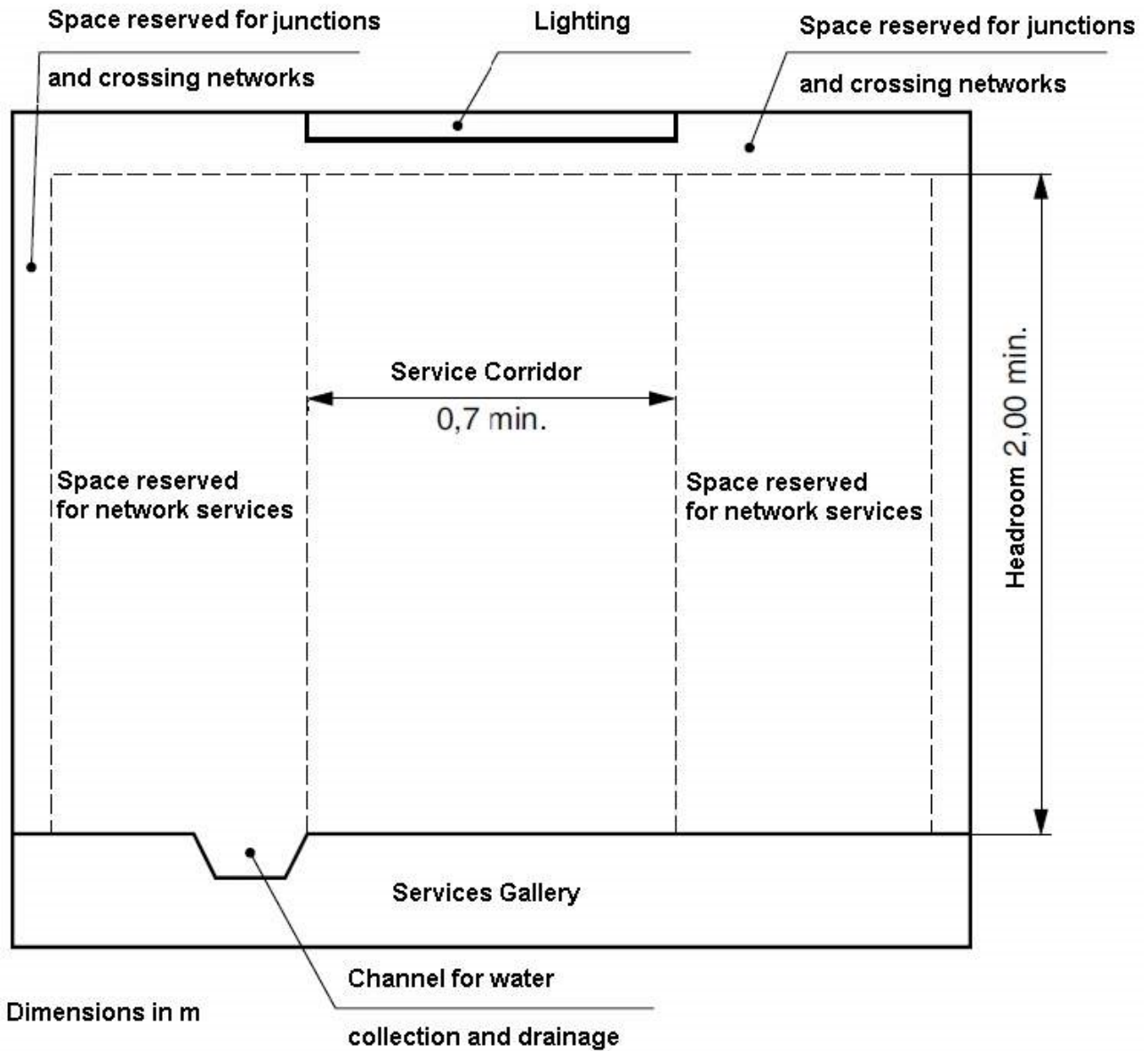
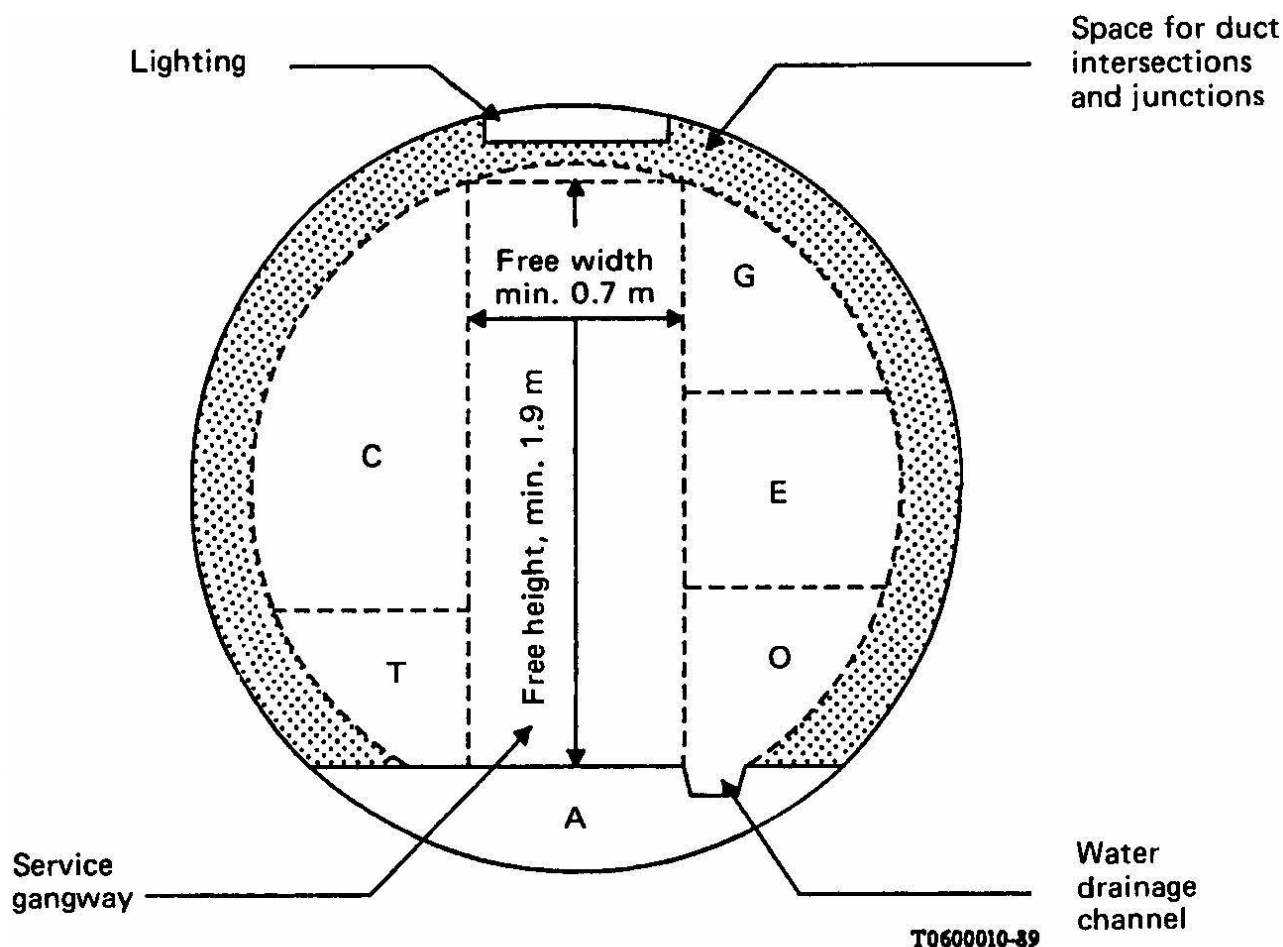


Figure 16 – Example Utility Tunnel of Rectangular Cross section  
 [Source: Italian Norm, b-29]



- T Telecommunication duct area (in tubes)
- E Power duct area
- G Gas duct area
- O Water duct area
- C District heating duct area
- A Waste water duct area

Figure 17 – Example Utility Tunnel with circular cross section  
[Source: ITU-T, b-28]

### 3.1.3 Advantages of Utility Tunnels

Advantages of Utility Tunnels include:

- Easier accessibility to utilities for maintenance, upgrading and future expansion [b-1]
- Environmental impacts are minimized: such as noise, vibration, dust, disruption to traffic and services, street maintenance requirements [b-1]
- Location information is made more accessible. Long-term collaboration among stakeholders often includes greater emphasis on making duct locations easily known [b-3]
- Utility ducts greatly reduce the per unit of surface area occupied [b-3]



- Ducts allow maintenance through their access points. Since access points mostly obviate new roadway intrusions, traffic delays from duct-related road works are greatly reduced and avoid the high cost of surface reinstatement [b-3]
- Sharing the higher initial installation cost of ducts across all services could make rural service, and SSC suburbs, more economically feasible. Where ducts are used, all networks are typically underground in multi-purpose ducts. Above-ground electricity and telecom poles are avoided, increasing safety and reducing natural disaster impacts [b-3]
- Common utility ducts are designed to accommodate anticipated new and evolving networks [b-3] saving the high cost of retrofitting
- An adequate airflow in ducts allows better heat transmission from electricity cables than in direct trenched/buried situations.

#### 3.1.4 Limitations/disadvantages of Utility Tunnels include:

- High initial construction cost as compared to traditional open excavation methods [b-1]
- The issue of compatibility between the utilities housed in the tunnel. A defect in one system may adversely affect the other systems. There has been considerable concern about compatibility between utilities, issues such as induction between electrical and communication lines, gas conduits explosion hazards, in-tunnel temperature rising due to heating and electrical lines.
- The concerns of people entering the tunnels to maintain one service when they are not experienced in dealing with other types of services (and associated risks) of other utilities.

#### 3.1.5 Resilience and reliability of a common infrastructure

An example of a utility duct with resilience is the Shin-Sugita Common Utility Duct [b-6]. To make local infrastructure more resistant to disasters, such as earthquake, a 220-kilometer common utility duct is being planned for the Yokohama-Kawasaki area in Kanagawa Prefecture. The common utility duct typically carries many different kinds of utility lines, including gas, electricity, water, sewage and other types of infrastructure that are indispensable to our daily lives. Once a common utility duct has been constructed, it is no longer necessary to excavate the street every time something must be replaced, and the ability to visually inspect water lines etc. greatly simplifies the task of maintenance. Furthermore, if an earthquake or other major disaster occurs, damage can be quickly pinpointed and repaired. Where common utility ducts are in place, a city is much better prepared to deal with emergencies.

GIFT City [b-2] includes connection to two telecommunications service providers which operate services in adjacent regions at opposite sides of the city. The advantage of this is that any user can opt for services from either service provider or both to ensure continuation of service in the event of a single point of failure.

#### 3.1.6 Provision for multiple service providers

A single authority is needed when a shared infrastructure such as a utility tunnel is to be provided and maintained.

For example in the new city Lavasa, India [b-7], a single appointed company establishes and maintains the assets such as dark fibers, rights of way, duct space and towers for the purpose of granting rights on lease/rent/sale basis to the licensees of telecom services licensed under section 4 of Indian Telegraph Act 1885 on mutually agreed terms & conditions.

This approach is pioneering as no authority traditionally exists in India to manage cooperation among utility stakeholders over such a wide range of services.



### 3.1.7 Risks or vulnerabilities which need to be considered with shared infrastructure

A utility tunnel with multiple service providers requires:

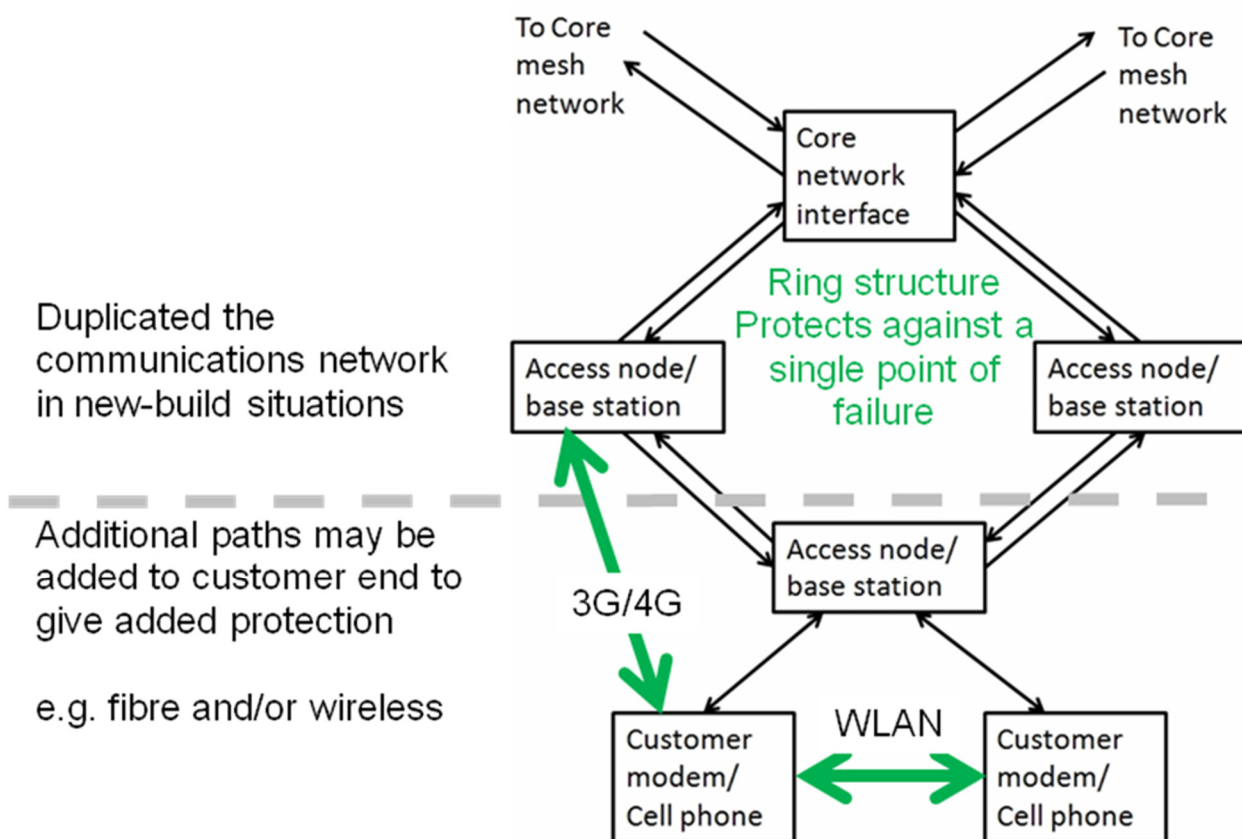
- Easy access for repair or maintenance
- Access authorization, security (keys/locks) to minimize theft and wilful damage
- Wet and dry partitions to maintain continuity of service in event of flooding.

Allowing for changes in climate is increasingly being considered as a factor which affects the lifecycle of an asset such as a railway or telecommunication facility [b-8]. A risk assessment of built infrastructure may be carried out according to guidelines in [b-8].

Dual networks and/or multiple service providers should be considered as methods to maintain service continuity against a single point of failure in telecommunications networks.

Example 1: Dual-fiber entry to all buildings with more than 100 occupants.

Example 2: Both wired and wireless (cellular) services to be accessible in all buildings.



**Figure 18 – Ensuring Telecommunications Service Continuity**  
 [Source: ITU-T, b-9]

The service provider protects the network to access nodes such as telecommunications exchanges using a synchronous digital hierarchy (SDH) ring. In the access network, wireless networks such as 3G/4G and Wireless LAN may be used to provide an alternative path to the fixed network.

It is not clear how the sensor layer network should be provided with resilience to a single point of failure close to and including the sensor (or actuator). For critical applications duplication of sensors may be required. This could be using a protected ring or on separate but interleaved networks.

The resilience of wireless sensor networks including protection against intrusion or deliberate jamming is the subject of research.

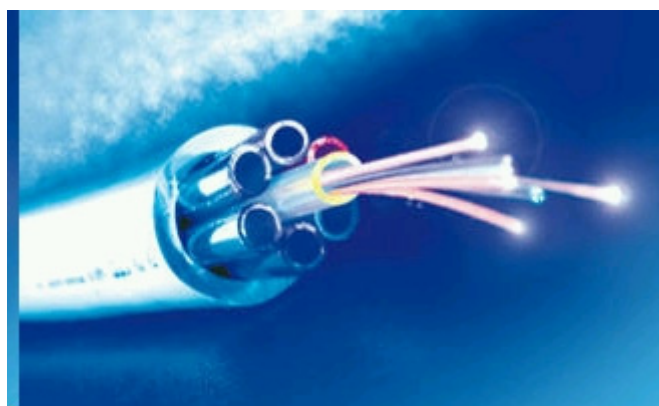
## 3.2 Growth, Maintenance and Upgrade in New Build Situations

### 3.2.1 Growth and flexibility for upgrade

Growth and flexibility for upgrade is required in all infrastructures. Provision of utility tunnels or accessible duct can save cost.

Fibre infrastructure for ICT services could be laid in easily-accessible covered trenches sharing conduits for optical fibre, electricity, fresh water, and possibly storm water sewerage if gravity flow can be maintained. There would be removable covers along the entire route length to ensure easy access for installation and maintenance. These covers could have a surface suitable for pedestrians or cyclists.

Retrofitting utility cables is costly. Blown fibre microducts should be considered to allow for addition or replacement of fibre as demand for services increases [b-11].



**Figure 19 – Air Blown Fibre Tubing**  
[Brand-Rex Ltd, b-12]

### 3.2.2 Provision for Branching

No branching is allowed in the utility tunnel according to [b-1].

Even so branching is essential for services involving gravity such as storm water run-off.

### 3.2.3 Identification and Location of nodes/plant

Provision is needed for identification and location of underground ICT infrastructure. Examples include barcodes and radio frequency identification tags.

As the sensor layer network evolves the precise geographic location of "a thing" will be critical. For example, wireless devices containing a battery will need locating to replace the battery.

### 3.3 Lifecycle and obsolescence

#### 3.3.1 Life of built infrastructures and provision for replacement

The built infrastructure may be considered to have a life ranging from 5-100 years. A common infrastructure therefore needs to be accessible to allow service providers to carry out work including new service provision, upgrade and replacement.

Examples of typical life times are: ICT (5 years), rail track and signalling (15-20 years, [b-8]), road surface (20 years, [b-8]), electricity (20 years), data centre 20 years [b-8], storm water run-off (30 years), water pipeline (100 years [b-8]), and sewerage (100 years [b-8]).

#### 3.3.2 The built-infrastructure – radical changes can be envisaged

Infrastructure, such as a utility tunnel, could have a lifetime of 100 years or more. The speed of technological advances especially in the ICT sector could render some of the city infrastructure obsolete within 10 years. Examples include: self-drive vehicles, tracked buses superseding rail, delivery services by autonomous vehicles including drones, solid refuse collection using underground ducting powered by suction of air. An issue for planners to consider is to what extent the infrastructure should be future-proofed.

Provision for additional storm water run-off is a major consideration for some cities as the impact of climate change is factored in. One example is G-Cans Project, or the Metropolitan Area Outer Underground Discharge Channel, which is the world's largest underground flood water diversion facility. It is located between Showa in Tokyo and Kasukabe in Saitama prefecture, on the outskirts of the city of Tokyo in the Greater Tokyo Area, Japan [b-13]. Utility tunnels may be an essential part of a SSC's storm water run-off plan.

#### 3.3.3 Powering the sensor layer network

Powering the sensor layer network is an important lifecycle consideration. Visiting remote locations to replace batteries in wireless sensors is an expensive service maintenance consideration. A battery life of less than 10 years can destroy a remote sensor business proposition. Wireline options should therefore be considered as an alternative to wireless devices.

##### Box 1

Example: Power over Ethernet [b-14] can power sensors or actuators in a sensor layer network without recourse to batteries or a separate electricity supply from the network connection.

##### Box 2

Example: The HomePlug Powerline Alliance (HPPA) has developed standards and technology enabling devices to communicate with each other, and the Internet, over existing home electrical wiring. Power and communications may therefore be combined over a common mains facility to sensors or actuators on the periphery.

**Box 3**

Example: USB Wall socket [b-15]. In the domestic environment USB wall sockets are available combining both a mains outlet and a USB charger outlet. Due to the reach limitation of 3 m the sockets would need a secondary communications path (e.g., HPPA) to enable communications to a central server.

**Box 4**

Example: Telephony cable (twisted pair) may be used to provide both backhauling (e.g. A/VDSL) and powering. This is a typical case of use of the telecommunication company's access network with power (e.g. power for a telephone or ADSL loop extender is provided along the line together with DSL signals for internet access).

## 4 Smart Sustainable Building Utility Services

---

### 4.1 Opportunities for sharing risers (e.g., inside or alongside buildings)

Utility tunnels require branching points under or alongside buildings, such as hotels or offices. Multiple service risers are then needed to carry services to the floors in the building. The example shown below is part of the prefabricated T-30A hotel [b-16].

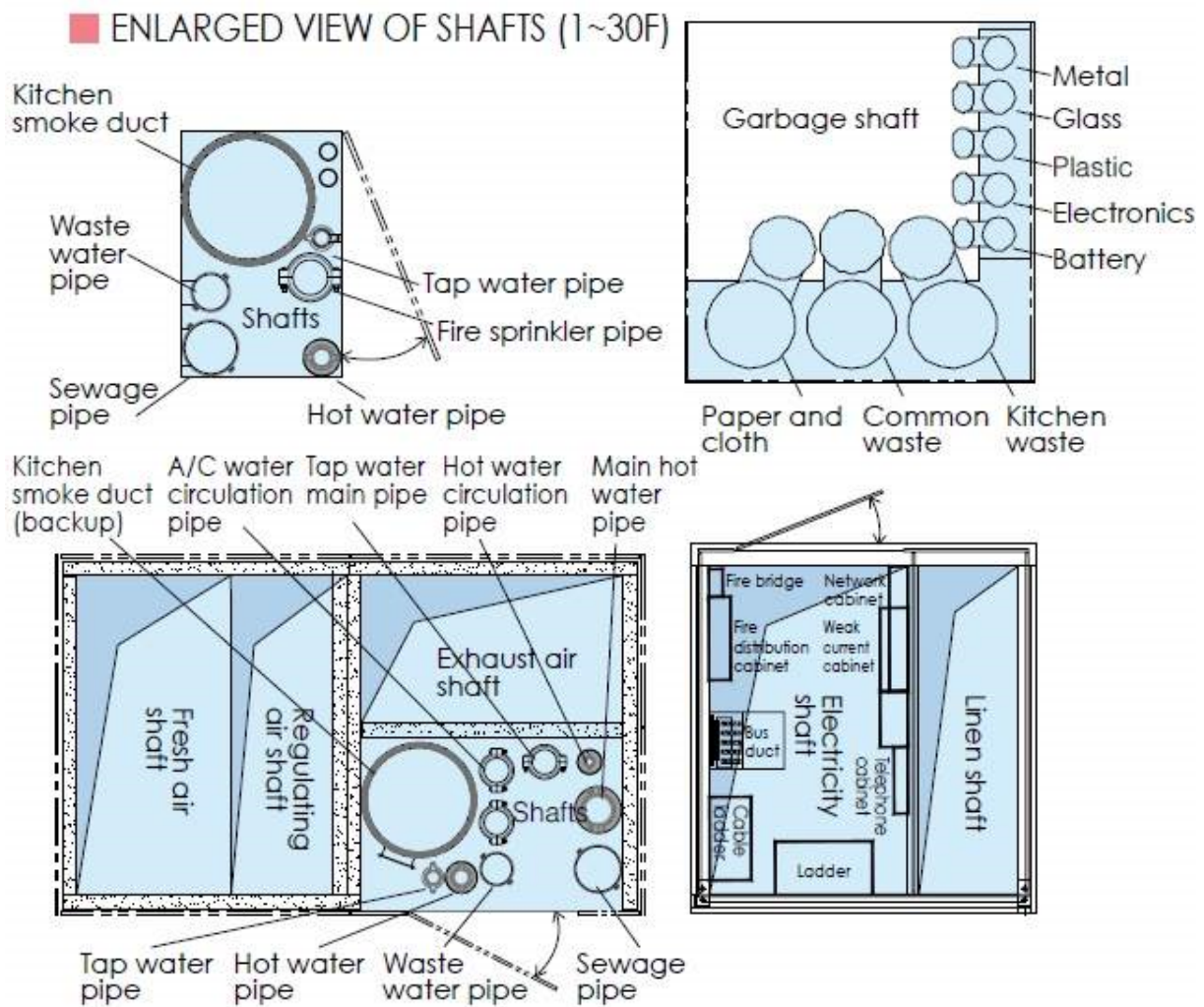
### 4.2 Smart Sustainable Building Service Requirements

A wider range of services are identified in [b-16] than in the utility corridor described in the introduction to Section 6.

The additional services include:

- Airshafts with separation of regulating (conditioned) air, fresh air and exhaust air
- Chimney duct to remove kitchen smoke
- A garbage shaft with separate ducts to remove: metal, glass, plastics, batteries, electronic waste, kitchen waste, paper and cloth waste.
- Linen shaft to allow linen to be sent to the laundry.

A consideration for SSC planners is to what extent these additional services could be carried in utility tunnels. If waste is to be collected could an additional facility be included in the utility tunnel to handle recyclable and other waste products. A further consideration for SSC planners is how the intersection between the horizontal and vertical section is designed and managed. Once inside the building the SSC planners are less responsible other than to ensure that buildings meet local planning regulations from the perspectives of safety and efficiency.



**Figure 20 – Utility Shafts in the T-30 Prefabricated Hotel**  
 [Source: BROAD Sustainable Building Co. Ltd., b-16]

[b-16] provides useful guidance on best practice for the ICT within a building such as a hotel. A sensor network is provided to each room for environmental control. This is shown below.

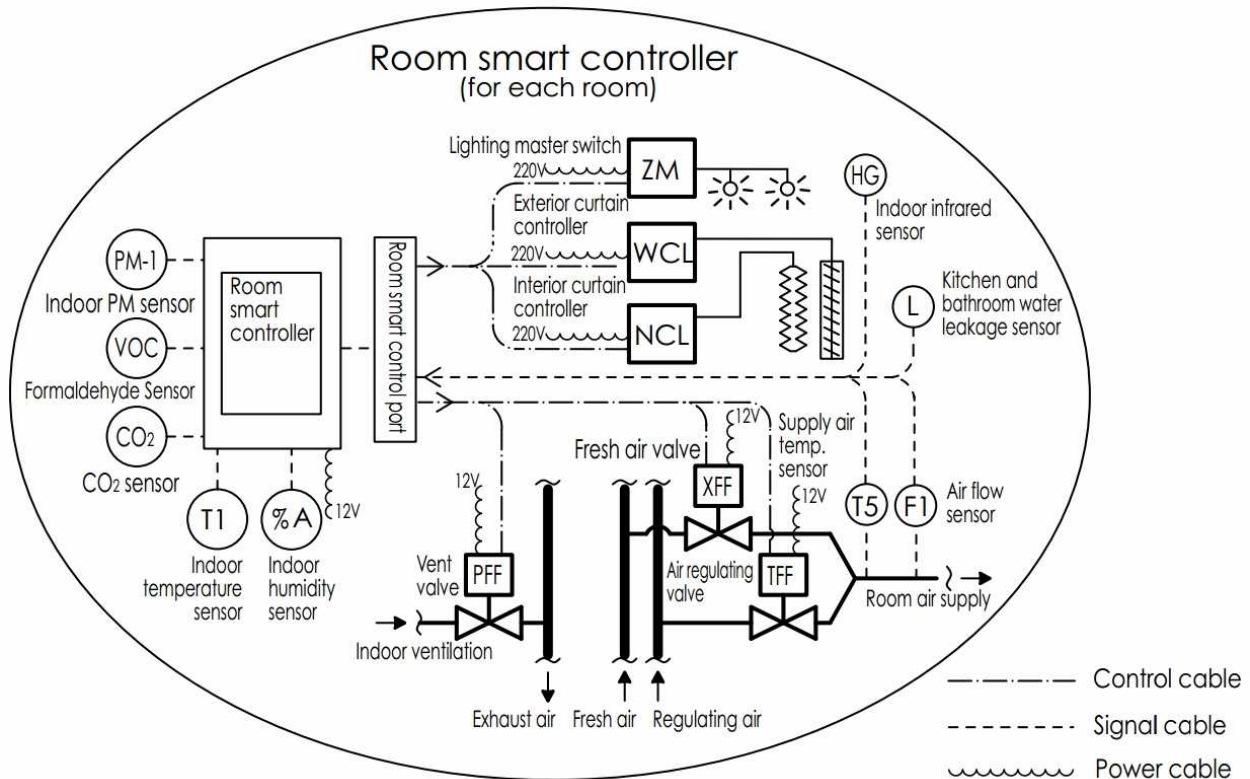
Environmental sensors include:

- Indoor temperature sensor
- Indoor humidity sensor
- Formaldehyde sensor [b-17] (for sick building sickness sufferers, for whom the World Health Organization has set a 30 min exposure limit of 0.08 ppm)
- CO<sub>2</sub> sensor
- Particulate Matter Sensor (Acceptable indoor air quality is an occupant need and should be sensed and controlled for. Particulate matter sensors measure the particulate concentration, which, at high levels, correlates to health problems [b-18])
- Indoor infrared sensor (for room occupancy)
- Water leakage sensor
- Air flow sensor



- Supply air temperature sensor
- Fire detection

NOTE - in some building types a gas leakage detector may be required



**Figure 21 – Smart Room Controller in the T-30 Prefabricated Hotel**  
 [Source: BROAD Sustainable Building Co. Ltd., b-16]

Room controllers include:

- Indoor ventilation
- Fresh air inlet
- Regulating air (conditioned air)
- Lighting
- Exterior shutter/curtain
- Interior curtain.

The wiring for the interior of the room (sensor network) is not described but with at least 15 connected devices represents a significant need for sensor infrastructure with a structured wiring loom and conduit, sharing infrastructure costs.



## ***5 Opportunities for sharing infrastructure at street level***

---

Opportunities for wireless mast and facility sharing are discussed in [b-19]. This document also mentions the opportunity for installing small base stations on street lampposts and use of wireless technology to provide traffic monitoring and traffic light synchronization. Duct sharing is very promising in enabling low cost installation of optical cables. Optical cables require very small space. Typically, a 144 fibre cable can be less than 1cm wide. Such cables can be fully dielectric too, so they are not subject to special requirements on safety.

Such duct sharing is valuable in new built areas, but looks even more fundamental in built areas where optical fibre overlay is required to add broadband capacity.

## ***6 Opportunities for ICT to support other utilities***

---

When facilities are shared between ICT and other utilities, the ICT is in close proximity to other utilities and may be used to support them at lower cost than when separate infrastructure is provided. The sensors can facilitate better monitoring and control and give advance warning of failure or blockages. Possible examples include:

- Flood detection sensors in utility ducts
- Fire detection sensors in utility ducts
- Temperature sensors in electric cables
- Gas leakage detectors
- Traffic flow monitoring
- Street lamp control
- Street lighting control
- Water utility (The sensor network needed for monitoring and control is illustrated below).

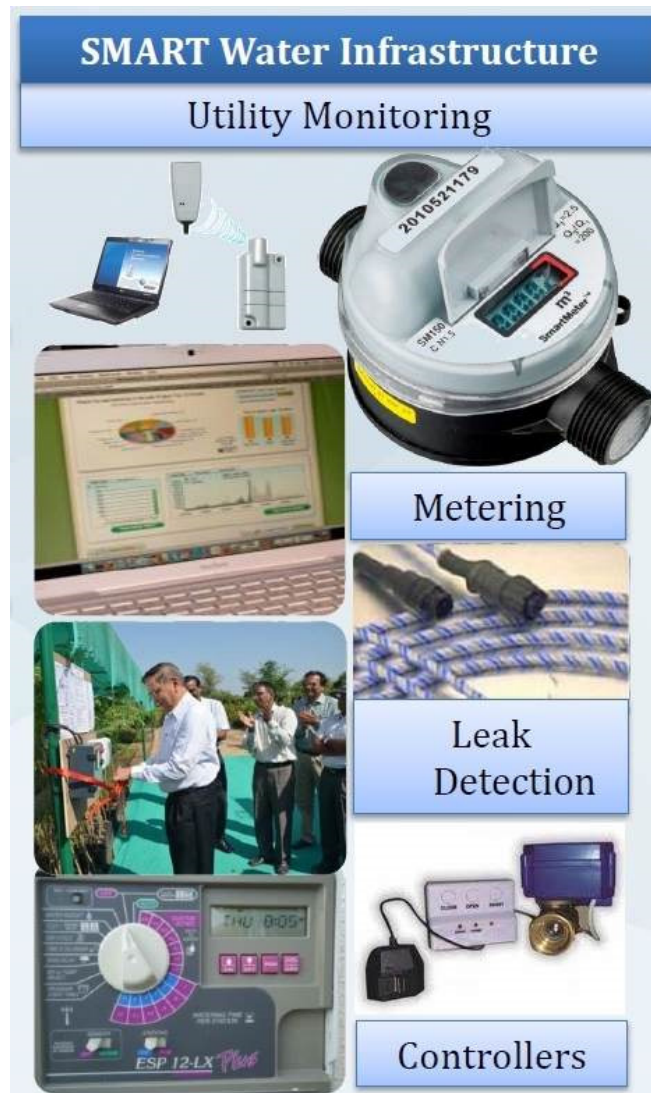


Figure 22 – The sensor network for water utility monitoring  
[Source: Nilesh Puery, b-2]

## 7 Opportunities for sharing the Application Platform

At the service layer a wide range of applications are envisaged for the SSC ranging from e-health to e-transport. Each requires termination onto a server, data storage, a smart processor and connection to devices including personal devices, sensors and controllers. Most existing cities have a multiplicity of platforms to support these services which have arisen because expertise for managing the various service classes resides in silos. When building a new SSC planners have the option to select a service platform which can handle the bulk of the software functions required by application developers on a single platform.

**Box 5 – Example of an open platform from the EU**

An example of an Open Platform for Application Program Interfaces (APIs) is FIWARE [b-20] which was funded by the European Union under the Seventh Framework Programme, which is a 100M Euro R&D Programme which seeks to provide an open, public and royalty-free managed service architecture for smart cities. This offers a set of open APIs that allow developers to avoid getting tied to any specific vendor, therefore protecting application developers' investments.

The FIWARE platform provides a rather simple yet powerful set of APIs (Application Programming Interfaces) that ease the development of Smart Applications in multiple vertical sectors. The specifications of these APIs are public and royalty-free. Besides, an open source reference implementation of each of the FIWARE components is publicly available so that multiple FIWARE providers can emerge faster in the market with a low-cost proposition.

FIWARE Lab is a non-commercial sandbox environment where innovation and experimentation based on FIWARE technologies take place. Entrepreneurs and individuals can test the technology as well as their applications on FIWARE Lab, exploiting Open Data published by cities and other organizations. FIWARE Lab is deployed over a geographically distributed network of federated nodes leveraging on a wide range of experimental infrastructures.

Could FIWARE meet your requirements for an open application platform for SSCs?

**Box 6 – Example of an open data platform from the City of Leeds UK**

Other options exist for sharing information such as direct posting of databases on a website [b-21]. This was done on a low budget with the aim of releasing public information rapidly at low cost. The aim is to ensure that all of our data sets meet quality assurance standards and where possible gain ODI certification [b-22]. The files are mostly in .csv spreadsheet format. So far 140 datasets have been published along with 82 downloadable APIs and community initiatives.

**Box 7 – Example of open data format**

"Proper database management, analytics and sharing of information can help increasing coordination between stakeholders. For sharing of files, .csv or .json format can be used because they are very fast to process, easy to manipulate and consume lesser memory. For the databases, eventually consistent non-relational databases can be considered because of their speed advantages" [b-23].

All the information of the facilities can be collected and converged to a holistic platform such as a city level integrated management system [b-25]. With integrated management for smart sustainable city, the sensors, and sensing networks can function in an organized way to detect various infrastructure. As a result, emergency events can be rapidly discovered and acquired. Then the services for information resource publishing and sharing as well as result fusing are provided to disseminate information across the concerned agencies. Thus the goal is achieved to make the city smarter and more sustainable.

## Annex A

### Glossary and list of abbreviations

#### Glossary

'Urban Corridor'. An urban corridor is more commonly understood as a roadway or boulevard etc. In this report it reaches from building-to-building and may include footpaths, tramways, avenues of trees, above ground and below ground infrastructure.

#### List of Abbreviations

API	Application Program Interface
CATV	Community Antenna Television
EMF	Electromagnetic Field
HPPA	HomePlug Powerline Alliance
ICT	Information Communication Technologies
IoT	Internet of Things
NOx	Oxides of Nitrogen
SSC	Smart Sustainable City

## Appendix I

### Bibliography

- [b-1] Abu Dhabi Urban Planning Council, "Abu Dhabi Utility Corridors Design Manual" Version 1  
[http://www.upc.gov.ae/template/upc/pdf/UCDM\\_Version-1-En.pdf](http://www.upc.gov.ae/template/upc/pdf/UCDM_Version-1-En.pdf)
- [b-2] Nilesh Puery: Presentation "Gujarat International Finance Tec-City" made at ITU Training Event "Leveraging ICTs for Smart Sustainable Cities for Asia-Pacific Region", Delhi, March 24-26, 2015.  
<http://www.itu.int/en/ITU-D/Regional-Presence/AsiaPacific/Pages/Events/2015/March%20SSC%202015/ITUTRAISSC2015.aspx>
- [b-3] World heritage Encyclopedia  
<http://www.worldheritage.org/article/WHEBN0002291091/Utility%20tunnel>
- [b-4] National Joint Utilities Group UK "NJUG Guidelines on the Positioning and Colour Coding of Underground Utilities Apparatus", Issue 8, 29 Oct. 2013.  
<http://www.njug.org.uk/wp-content/uploads/V1-Positioning-Colour-Coding-Issue-8.pdf>
- [b-5] UK Department of Transport, "Code of Practice for the Co-ordination of Street Works and Works for Road Purposes and Related Matters", page 19  
[https://www.gov.uk/government/uploads/system/uploads/attachment\\_data/file/43578/street-works-code-of-practice.pdf](https://www.gov.uk/government/uploads/system/uploads/attachment_data/file/43578/street-works-code-of-practice.pdf)
- [b-6] Kajima, Corporation, "Shin-Sugita Common Utility Duct"  
<http://www.kajima.co.jp/english/csr/infra/safety/#lifeline>
- [b-7] Satish Kamat: Presentation, "Lavasa" made at TRAI ITU Symposium "ICT Regulatory challenges in Indian Smart Cities" 27 March 2015, New Delhi, India, personal communication for this document.
- [b-8] UK Government, "Climate Resilient Infrastructure: Preparing for a Changing Climate"  
[https://www.gov.uk/government/uploads/system/uploads/attachment\\_data/file/69269/climate-resilient-infrastructure-full.pdf](https://www.gov.uk/government/uploads/system/uploads/attachment_data/file/69269/climate-resilient-infrastructure-full.pdf)
- [b-9] ITU-T "Resilient pathways: the adaptation of the ICT sector to climate change, page 27  
[http://www.itu.int/en/ITU-T/climatechange/Documents/Publications/Resilient\\_Pathways-E.PDF](http://www.itu.int/en/ITU-T/climatechange/Documents/Publications/Resilient_Pathways-E.PDF)
- [b-10] Mole Solutions Ltd "Urban Freight Pipeline Project". April 2015  
<http://www.molesolutions.co.uk/our-latest-news/>
- [b-11] Networx3 "The Benefits of Blown Fibre"  
<http://www.networx3.co.uk/resources/the-benefits-of-blown-fibre/>
- [b-12] Brand-Rex Ltd "Air Blown Optical Fibre Solutions"  
<https://www.brand-rex.co.uk/Products/Optical-Systems/Air-Blown-Fibre-System>
- [b-13] G-Cans Project, Kasukabe, Saitama, Greater Tokyo Area, Japan  
<http://www.water-technology.net/projects/g-cans-project-tokyo-japan/>
- [b-14] IEEE Standard IEEE 802.3 series; see IEEE 802.3af-2003 and the higher power IEEE 802.3at-2009. These are both included in 802.3-2012.

- [b-15] BRE Trust  
[http://www.designingbuildings.co.uk/wiki/Power\\_over\\_USB](http://www.designingbuildings.co.uk/wiki/Power_over_USB)
- [b-16] BROAD Sustainable Building Co. Ltd. 'Tower Hotel Technical Briefing'  
<http://en.broad.com/uploads/pdf/tsjd.pdf>
- [b-17] Po-Ren Chung, et al., "Formaldehyde Gas Sensors: A Review"  
<http://www.ncbi.nlm.nih.gov/pmc/articles/PMC3673094/>
- [b-18] Kevin Weekly, et al., "Low-cost coarse airborne particulate matter sensing for indoor occupancy detection", 2013 IEEE International Conference on Automation Science and Engineering,  
[http://bayen.eecs.berkeley.edu/sites/default/files/conferences/Low-cost\\_coarse\\_airborne.pdf](http://bayen.eecs.berkeley.edu/sites/default/files/conferences/Low-cost_coarse_airborne.pdf)
- [b-19] ITU-T FG SSC Report "EMF Considerations in Smart Sustainable Cities", 2014, page 31
- [b-20] "FIWARE an Open Interface for Open Minds"  
<http://www.fiware.org/about/>
- [b-21] Leeds City Council, UK, "Leeds Data Mill",  
<http://www.leedsdatamill.org/>
- [b-22] The Open Data Institute  
<https://certificates.theodi.org/>
- [b-23] Personal Communication: Neeraj Mishra of TRAI, India, March 2015.
- [b-24] ITU-T FG-SSC deliverable, Technical Report on electromagnetic field (EMF) consideration in smart sustainable cities (2014).
- [b-25] ITU-T FG-SSC deliverable, Technical Report on integrated management for smart sustainable cities (2015).
- [b-26] Standard of Ministry of Construction of China CJJ 61-2003, Technical specifications for detecting and surveying underground pipelines and cables in city (2003), in Chinese.
- [b-27] ITU-T Recommendation L.79 "Optical fibre cable elements for microduct blowing-installation application"  
<http://www.itu.int/rec/T-REC-L.79-200807-I>
- [b-28] ITU-T Recommendation L.11 "Joint use of tunnels by pipelines and telecommunication cables, and the standardization of underground duct plan", 1988.  
<http://www.itu.int/ITU-T/recommendations/rec.aspx?rec=1415>
- [b-29] Multipurpose underground facilities for the coexistence of network services different Design, construction, management and use General criteria and safety, Italian Norm. UNI CEI 70029, Sept 1998  
<http://webstore.ceiweb.it/webstorecopertina.aspx?ID=3780&PR=NO>





WORD

CRACKER

CYBER

ENCRYPTION

TROJAN

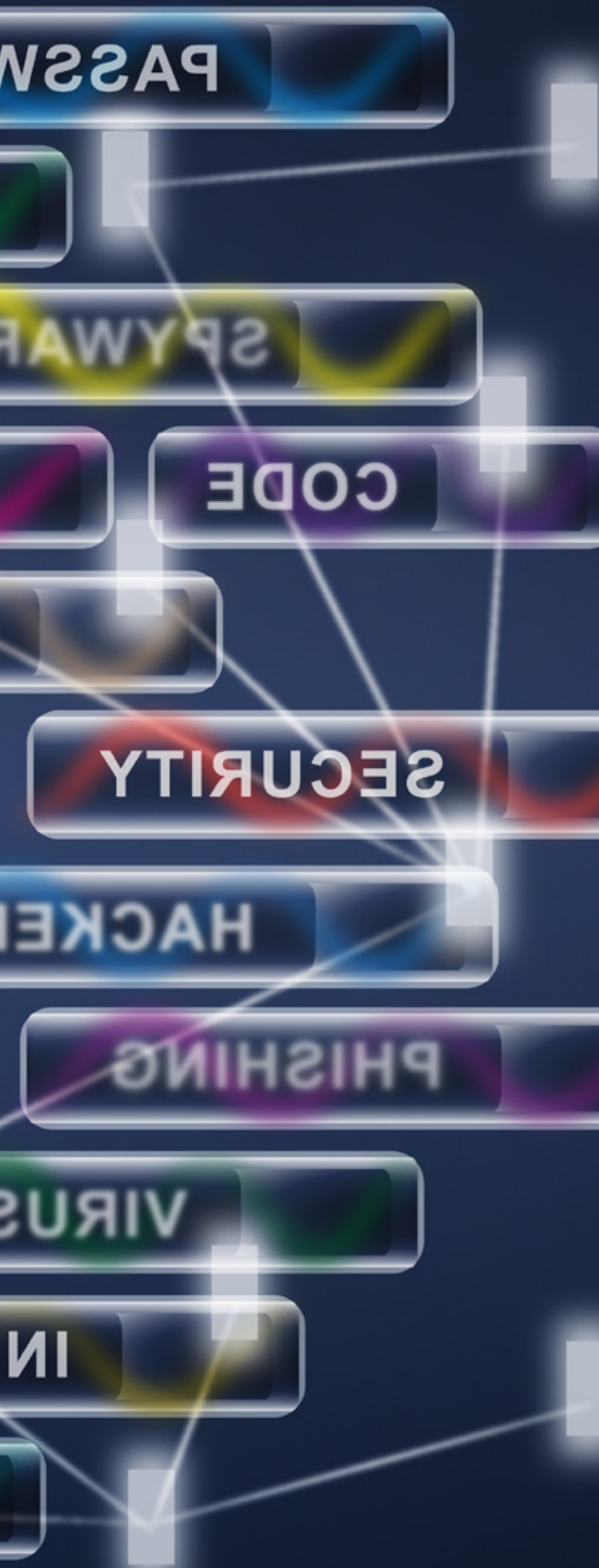
IDENTITY

THEFT

PRIVACY

TRUSION

DETECTION



# 3.4

Cybersecurity, data protection and cyber resilience in smart sustainable cities

## Acknowledgements

This Technical Report was prepared by Giampiero Nanni (Symantec), in collaboration with Ziqin Sang (Fiberhome Technologies Group). The authors wish to acknowledge the guidance and support from all the members of the ITU-T FG-SSC Management Team, and especially Paolo Gemma (Huawei), Angelica V. Ospina (University of Manchester), Michael Mulquin (IS Communications Ltd), Sian John (Symantec), Wei Qin (Fiberhome Technologies Group) who have provided constructive comments towards the successful completion of this Technical Report.

Additional information and materials relating to this Technical Report can be found at: [www.itu.int/itu-t/climatechange](http://www.itu.int/itu-t/climatechange). If you would like to provide any additional information, please contact Cristina Bueti at [tsb5@itu.int](mailto:tsb5@itu.int).

## Table of Contents

	<b>Page</b>
<b>1 Introduction .....</b>	<b>428</b>
1.1 Scope .....	428
<b>2 Key definitions.....</b>	<b>429</b>
<b>3 ICT implications in smart sustainable cities.....</b>	<b>430</b>
<b>4 Architecture of SSC.....</b>	<b>431</b>
<b>5 SSC services, potential cyberthreats and protective measures.....</b>	<b>433</b>
<b>6 SSC components and their vulnerabilities.....</b>	<b>439</b>
<b>7 Security architecture of SSC.....</b>	<b>441</b>
<b>8 Cybersecurity and a SSC governance framework .....</b>	<b>443</b>
<b>9 Recommendations to ensure SSC service continuity.....</b>	<b>444</b>
<b>10 Conclusions .....</b>	<b>447</b>
<b>Abbreviations.....</b>	<b>448</b>
<b>Bibliography .....</b>	<b>450</b>





## Cybersecurity, data protection and cyber resilience in smart sustainable cities

### Overview

Smart and sustainable city deployments will be carried out by a diverse ecosystem of providers in innovative domains, involving state-of-the-art technology, including critical and complex information and communication technology (ICT) implementations.

These deployments can address different components and city systems, like intelligent transportation, connected health care, public safety and security, emergency services, smart grid and smart metering, intelligent buildings, etc.

Increasing ICT complexity, hyper-connectivity, namely through “Internet of Things” (IoT) environments, as well as the generation of significant amounts of data, will also mean increasing vulnerability, both to malicious attacks and unintentional incidents. By conceiving interconnected urban systems with cybersecurity and data protection in mind, city administrators will be able to ensure service continuity, safety and well-being for citizens and businesses alike.

This Technical Report details these cybersecurity and data protection considerations in smart and sustainable city developments. It will explore the requirements and challenges of creating a secure, reliable and resilient smart and sustainable city. It will also consider how administrations and the overall city ecosystems will need to provide innovative, resilient “smart” solutions that leverage digital information while protecting against malicious violations, unintentional damage and natural disasters.



## Executive Summary

Smart sustainable cities (SSC) are highly dependent on information and communication technologies (ICTs), including Internet of Things (IoT), radio frequency identification (RFID), and machine-to-machine (M2M). The advanced underlying infrastructure not only resolves the need for hyper-connectivity for smart sustainable city components and services, but also introduces higher levels of complexity and higher volumes of data. Increased system complexity opens new doors and opportunities for malicious cyberattacks and data loss in the case of serious incidents, including natural disasters. The linkages that exist between the higher levels of complexity, connectivity and data volumes that characterize SSC, which together lead to exacerbated levels of vulnerability to security threats, can be summarized as follows:

**Hyper complexity + hyper connectivity + hyper data volumes = hyper vulnerability**

Given the increasing interconnectedness of smart sustainable city environments, security incidents can prove highly penalizing for the systems they affect, for the city services they control, and ultimately for the citizens and end users of the services.

A very compelling need for SSC is therefore to guarantee the protection of the relevant ICT systems and the various technologies involved, as well as the data used to govern the systems and the services.

Cybersecurity, information protection and system resilience constitute political and governance issues at the forefront of new developments in this field. As they closely relate to both governance and policy, they require the attention of public administrators and decision-makers, especially given the potential effects of malicious attacks and disasters on critical ICT systems and infrastructure, including citizens' deprivation of essential services, from transportation to utilities (e.g. smart grid, water management), health care, emergency services, and public safety, among others.

With appropriate processes in place, multi-stakeholder collaboration and good governance, technology can provide tangible solutions to issues related to cybersecurity, information protection and system resilience.

Within this context, this Technical Report provides a detailed account of the potential cyber-vulnerabilities of SSC, and a set of Recommendations to ensure the protection and resilience of the services offered to the citizens.

This Technical Report is structured around nine sections.

Section 1 provides the introductory background and scope. Section 2 provides working definitions for the notions that are at the core of this Technical Report, namely "resilience", "cybersecurity" and "data protection". Section 3 describes the main implications of ICT use in the contexts of SSC. It explores the IoT, the rising technology at the base of the SCC paradigm, as well as other ICTs that introduce new potential threats to the integrity and security of the systems involved. Section 4 provides a general overview of the technical architecture of SSC in order to contextualize the analysis and to illustrate the complex security challenges faced by SSC strategists and implementers.

Based on this context, section 5 describes a number of examples of SSC services and security threats, providing the reader with a series of practical recommendations aimed at countering potential cyber-vulnerabilities in those areas. Section 6 expands the technical architecture concepts by analysing the different technologies components and their vulnerabilities. Section 7 details the analysis by presenting the technical cybersecurity architecture of SSC.

Section 8 highlights the need for a SSC governance framework that provides, among others, the leadership required for the design and effective adoption of cybersecurity and resilience approaches in smart sustainable cities.

Building on this analysis, section 9 guides the reader through a series of key recommendations on how to effectively maintain service continuity despite the occurrence of different types of incidents, with varying levels of impact.

This Technical Report concludes by advocating cybersecurity and cyber resilience as vital ingredients of SSC, and as part of the collaborative efforts between SSC stakeholders aimed at ensuring service continuity, reliability, citizen privacy, and ultimately the achievement of SSC goals.

# 1 Introduction

---

For the first time in history, more than 50% of the world's population live in cities<sup>1</sup>.

The projected rates of urban growth will bring benefits and challenges. Demographic and social ecosystems will need to evolve, economies will be under increased pressure, the environment will be challenged, city governance will have to adapt, digital and social inclusion needs will grow, and health care and education provision will demand new approaches, among others.

In order to address these challenges, cities need to become, and in many cases are already becoming, 'smart', by ensuring a more rational approach to the way services are operated and delivered, and by aiming at a better and more sustainable quality of life for city inhabitants.

ITU-T Study Group 5 "Environment and Climate Change" and UNECE define a smart sustainable city as "*an innovative city that uses information and communication technologies (ICTs) and other means to improve quality of life, efficiency of urban operation and services, and competitiveness, while ensuring that it meets the needs of present and future generations with respect to economic, social, environmental as well as cultural aspects*".

As ICTs are a key enabler of SSC, the systems involved can profit from the ability to be highly interconnected through various technologies. For example, a broad variety of applications will be introduced based on the Internet (e.g. e-government, e-commerce, e-money, online banking), while IoT will be adopted in applications such as intelligent transportation, connected health care, public safety and security, emergency services, smart grid and smart metering and intelligent buildings, among others.

In order to guarantee service continuity and integrity, the ICT systems that oversee and control smart and sustainable cities need to consider, from the initial stages of inception and design, measures to ensure cybersecurity, robustness, reliability, privacy, information integrity, and crucially, resilience.

## 1.1 Scope

This Technical Report explores the requirements and challenges involved in creating a secure, reliable and resilient smart sustainable city. It considers how administrations and the overall city ecosystem will need to provide innovative, resilient "smart" solutions that leverage digital information while protecting against malicious violations, unintentional damage and natural disasters.

The content of this Technical Report is aimed at an audience of SSC stakeholders, including city officials and administrators, among others, described in the Technical Report on SSC Stakeholders.

When required, reference is made to other Technical Reports that have been prepared as part of the mandate of ITU-T Focus Group on Smart Sustainable Cities<sup>2</sup>.

---

<sup>1</sup> UNFPA (2007), *State of the World Population 2007: Unleashing the Potential of Urban Growth*, United Nations Population Fund (UNFPA). Available at: <http://www.unfpa.org/swp/2007/english/introduction.html>.

<sup>2</sup> The Technical Reports are available on the website of the ITU-T Focus Group on Smart Sustainable Cities at: <http://www.itu.int/en/ITU-T/focusgroups/ssc/Pages/default.aspx>.

## 2 Key definitions

---

The notions of "resilience", "cybersecurity" and "data protection" are gaining increasing momentum, and are becoming extremely pertinent in a smart sustainable city context as they relate to the risks posed to service continuity by threats from the cyberspace. While available literature in this field offers a wide range of definitions for these terms<sup>3</sup>, which often vary according to the area or the sector of implementation, the following constitute the working definitions that will be used for the purposes of this Technical Report:

### a. Resilience

ITU-T Study Group 17 (SG17) defines resilience as the "Ability to recover from security compromises or attacks."

The FG-SSC has noted the ITU-T Study Group 17 Recommendations related to Cybersecurity Information Exchange (CYBEX), X.1500-Series. (ITU-T X.1500-Series Recommendations). Complementing this focus, a recent ITU report on 'Resilient Pathways' defines resilience as "*The ability of a system or a sector to withstand, recover, adapt, and potentially transform in the face of stressors such as those caused by climate change impacts*"<sup>4</sup>.

This Technical Report suggests that the resilience of ICT systems is linked to a series of attributes, which can be linked to security as follows:

- *Robustness* and ability to maintain performance and to continue operating, even under a cyber-attack or other incident (e.g. natural disaster).
- *Redundancy* of system components that allow the system to resume operations, within a defined delay of time, in case of abrupt interruption, total or partial.
- *Flexibility and adaptability* to new circumstances, including the systems' ability to prepare for future threats by adjusting/rectifying issues that allowed the incident to occur, or that took place during an incident.

Achieving resilience and cyber resilience in a SSC context will ensure service continuity to its citizens.

### b. Cybersecurity

This concept refers to the discipline of ensuring that ICT systems are protected from attacks and incidents, whether malicious or accidental, threatening the integrity of data, their availability or confidentiality, including attempts to illegally "exfiltrate" sensitive data or information out of the boundaries of an organization.

---

<sup>3</sup> For example, the U.S Department of Homeland Security refers to resilience as "The ability to prepare for and adapt to changing conditions, and withstand and recover rapidly from disruptions. Resilience includes the ability to withstand and recover from deliberate attacks, accidents, or naturally occurring threats or incidents". The Information Security Forum defines cyber-resilience as "The organisation's capability to withstand negative impacts due to known, predictable, unknown, unpredictable, uncertain and unexpected threats from activities in cyberspace", while the World Economic Forum (WEF) refers to it as "The ability of systems and organisations to withstand cyber-events, measured by the combination of mean time to failure and mean time to recovery".

<sup>4</sup> Ospina, A.V., Bueti, C., Dickerson, K., and Faulkner, D. (2013), *Resilient Pathways: The Adaptation of the ICT Sector to Climate Change*, International Telecommunication Union (ITU), Geneva, Switzerland. Available at; [http://www.itu.int/en/ITU-T/climatechange/Documents/Publications/Resilient\\_Pathways-E.PDF](http://www.itu.int/en/ITU-T/climatechange/Documents/Publications/Resilient_Pathways-E.PDF).

This applies to the network and server environments, as well as to the endpoints (i.e. the individual terminals), in-house or mobile. Cybersecurity includes software tools, processes and people as key components of a successful implementation of the discipline.

### *c. Data protection*

This notion refers to the tools and processes used to store data relevant to a certain ICT system or environment, as well as recover lost data in case of an incident – be it fraudulent, accidental or caused by a natural disaster.

One critical element about data is the concept of data ownership, which refers to who is in charge of data, who can authorize or deny access to certain data, and is responsible for its accuracy and integrity, in particular personally identifiable information (PII). This aspect is expanded in the FG-SSC Technical Report on “Anonymization infrastructure and open data for smart sustainable cities”<sup>5</sup>.

These definitions provide the basis for the analysis presented in subsequent sections of this Technical Report. As the analysis will demonstrate, their consideration and effective integration as part of SSC strategies is crucial to ensure the continuity of service provision in situations of shocks or stress, but equally important, to ensure high standards of quality, trust and reliability on ICT infrastructures and services, all required for SSC to succeed.

## **3 ICT implications in smart sustainable cities**

---

The underlying nature of smart sustainable cities involves systems and objects interconnected through various technologies.

The IoT is a key element of SSC developments and refers to devices with embedded technology (e.g. sensors), and/or with Internet protocol (IP) addresses, able to be reached and exchange information, for example, in an intelligent transportation system.

The amount of data generated by these technologies can reach a considerable size. Big data will need to be appropriately and centrally stored, managed, analysed, and protected. The city operation's center will supervise the interaction between systems and will have to ensure continuity, integrity and resilience.

With time, the interconnected and interdependent services of smart cities will evolve under a centralized governance dashboard of specialized stakeholders, responsible for setting policies and processes, managing ICT assets, services and protocols, and ultimately administering the services for constituents. ICT control and management capabilities will be crucial in order to guarantee an efficient, secure and resilient governance and delivery.

Strategic information technology (IT) trends like virtualization, cloud and mobile, are cornerstones of operational effectiveness and efficiency.

At the same time, business-critical IT applications are increasingly running on virtualized servers, while cloud services are expanding into core exploration and production processes.

---

<sup>5</sup> FG-SSC deliverable, *Technical Report on anonymization infrastructure and open data for smart sustainable cities*. Available at <http://www.itu.int/en/ITU-T/focusgroups/ssc/Pages/default.aspx>.

As an increasing number of experiences suggest, mobile technologies improve the collaboration of users and the connectivity of smart devices across widely distributed infrastructure assets<sup>6</sup>.

The European Network and Information Security Agency (ENISA) indicates that "processes" are seen as the most important pillar to secure critical infrastructures and industrial control systems (ICSs) – much more important than technology and people. Therefore, focusing solely on IT data centers and operation control centers is not enough. As the supply chain and technical infrastructure domains become highly complex, a comprehensive end-to-end approach is necessary. Each part of the industry value chain needs to be analysed, assessed and secured – but not in an isolated way.

Governance, Risk and Compliance (GRC) is a key discipline for public sector organizations. GRC is to be fulfilled through policies and processes, enabled by ad hoc IT suites conceived to ensure that IT departments monitor their environment against the evolving regulation scenarios, and involves taking appropriate action to stay compliant and mitigate risks.

SSC security officers should consider the following measures as part of their GRC framework, and as part of their overall SSC security strategy:

- Embedding security with data to achieve confidentiality, integrity and authentication.
- Managing smart endpoints and embedded systems, as SSC will need to manage an increasing number of smart devices and secure data, identity and services across the entire supply chain, to avoid these devices being compromised and opening an additional threat vector.
- Protecting data explosion, including real-time information, which involves a sound management approach to storing, protecting, backing-up, archiving and retrieving data whenever needed.

## 4 Architecture of SSC

In order to provide a general background of the complex architecture that characterizes SSC, this section provides an overview of a sample configuration of SSC infrastructure. Gaining awareness of the complex, multi-layered architecture of SSC's infrastructure constitutes an important step towards the design of a comprehensive, system-wide cybersecurity strategy.

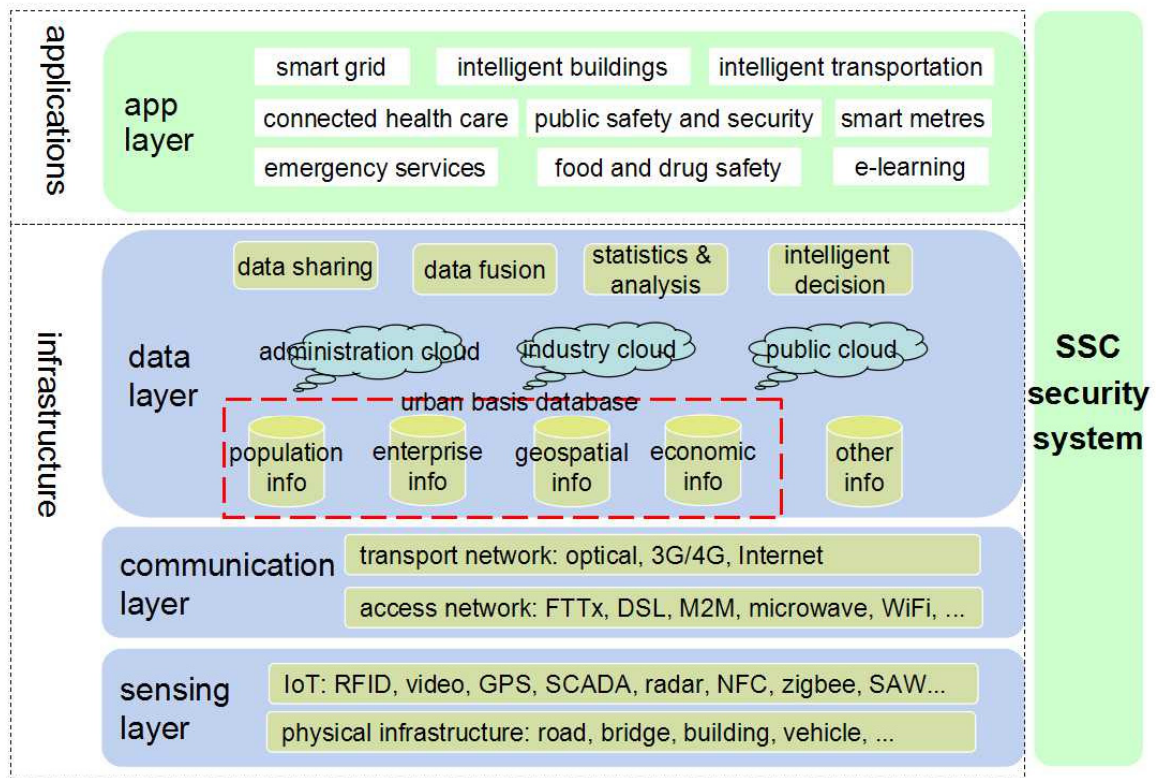
The architecture of SSC is divided into a sensing layer, a communication layer, a data layer and an application layer (Figure 1 from bottom to top), and is overseen by the SSC security system. Each of these components is explained in detail in the FG-SSC Technical Report on "Overview of smart sustainable cities infrastructure"<sup>7</sup>.

---

<sup>6</sup> Examples are available in the FG-SSC deliverable, *Technical Report on overview of smart sustainable cities infrastructure*. Available at <http://www.itu.int/en/ITU-T/focusgroups/ssc/Pages/default.aspx>.

<sup>7</sup> FG-SSC deliverable, *Technical Report on overview of smart sustainable cities infrastructure*. *Ibid.*





Source: FG-SSC deliverable, *Technical Report on overview of smart sustainable cities infrastructure. Ibid.*

**Figure 1 – Architecture of a smart sustainable city**

While a more in-depth explanation of the architectural components of SSC's infrastructure is beyond the scope of this Technical Report, a general overview of each of the layers is provided in Box 1.

**Box 1. Layers of the SSC architecture**

- The **sensing layer** is the basic requirement for SSC to achieve its "smart" component. It provides the superior 'environment-detecting' ability and intelligence for monitoring and controlling the infrastructure, the environment, the buildings and the security within the city. It uses radio frequency identification (RFID) devices, sensors, supervisory control and data acquisition (SCADA) and other Internet of things technologies, providing ubiquitous and omnipotent information services and applications for individuals and society.
- The **communication layer** is the "infobahn" or the backbone of SSC. The communication network should consist of large-capacity, high-bandwidth, highly reliable optical, pervasive networks, to relay and transport the city's intelligence. At the same time, the citizens can access the network "anytime, anywhere, on-demand", and can enjoy broadband services such as interactive personality television (IPTV), high-definition television (HDTV), and high-definition video calls.
- Data is a vital and strategic resource of smart and sustainable cities. The **data layer** makes the city "smarter": its main purpose is to ensure that fragmented data is shared by the functions of data association, data mining, and data activation. The data layer contains data center from industries, departments, enterprises, as well as the municipal dynamic data center and data warehouse, among others, established for the realization of data sharing and data activation.
- The **application layer** includes the various applications that manage the SSC's systems. This level exploits the previous layers and operates using their services.

Source: ITU-T FG-SSC (2014)

## 5 *SSC services, potential cyberthreats and protective measures*

As the overview provided in the previous section suggests, the infrastructural architecture of SSC can be vulnerable to a number of threats given its complexity, cross-level nature, and extent. According to the Internet security threat report (2014) by Symantec<sup>8</sup>, targeted attacks have increased by 91% in 2013, with a wide variety of attackers and motivations, and increasingly sophisticated techniques.

The dramatic increase in cyberattacks can be explained by the fact that more and more motivations can effectively and efficiently be served through the Internet. Perpetrators are attracted and can succeed, because cyberattacks are less detectable than physical actions, they do not physically expose the attackers, can be extremely inexpensive, can be launched by a geographically remote location, the attribution is extremely difficult, and even if someone is identified, the prosecution is even more problematic due to the lack of definitive international legislation and uncertain jurisdiction.

---

<sup>8</sup> Symantec (2014), *Internet security threat report 2014 – Volume 19*. Available at: [http://www.symantec.com/content/en/us/enterprise/other\\_resources/b-istr\\_main\\_report\\_v19\\_21291018.en-us.pdf](http://www.symantec.com/content/en/us/enterprise/other_resources/b-istr_main_report_v19_21291018.en-us.pdf)

Hackers' motivations can range from a criminal intent aimed at financial gain, through to industrial espionage, cyber sabotage, cyber warfare, and political activism, among others. Any of these can be conceived, take place, and have damaging repercussions in SSC.

Numerous episodes of city-infrastructure sabotage have been recorded in recent times, suggesting that ICT vulnerabilities can jeopardize the safe delivery of services to citizens, and/or their continuity.

Vulnerabilities can involve data "in transit" (i.e. being transmitted between devices) or "at rest" (i.e. while stored). Malicious attackers will assess the vulnerability of the different systems and engineer the most effective and damaging approach according to their objectives.

The following are examples of SSC services that are vulnerable to the above-mentioned threats:

- **Smart grid, intelligent buildings and other critical infrastructure**

It is generally estimated that cities are responsible for between 60% and 80% of the world's energy use. Therefore, optimizing energy delivery and consumption is vital.

Smart grid technology aims to tailor the generation and supply of energy to user consumption, thus increasing efficiency, reducing costs and environmental impact. In particular, consumer "smart meters" and sensors, equipped with IP addresses, can communicate information about energy utilization patterns to the supplier, while allowing end-user control. This can help manage real-time demand, and even provide advice to consumers about their use habits.

Buildings, both residential and commercial, provide an important opportunity to optimize energy consumption and enhance the well-being of residents and workers. Intelligent buildings, particularly office environments, are able to leverage smart grid technologies to influence energy supply and consumption by controlling lighting, climate control and IT. They can even provide electric plug-in stations for employees to recharge their cars while at work.

Smart grids and related infrastructure need protection from attacks that could cause severe stoppages to cities, community sites, industrial sites and essential services.

Attackers exploiting vulnerabilities in SCADA systems, based on traditional software platforms, can lead to intrusions with the potential to disrupt data exchange between utility control centers and end users, and severely compromise the delivery of energy services. Whitelisting techniques, used to ensure that only specified system applications and processes are active at any one time, are particularly effective against zero-day vulnerabilities and attacks in SCADA environments. Zero-day vulnerabilities are still unknown on the day of the attack, hence vulnerabilities against which no vendor has released a patch.

Intruders can also install malware designed to obtain sensitive information, to control the networks that operate the service and cause a denial-of-service situation. This can be countered through intrusion prevention techniques, coupled with robust policies in areas such as network usage, browser patches, e-mail usage, as well as users' awareness of the issue and their education and preparedness on the subject.

At the end-user level, smart meters may simply be hacked and compromised for fraudulent purposes: to alter proof of consumption or to 'steal' energy from other users, while preventing the provider from detecting service flaws.

**Recommendations**

- Public key infrastructure (PKI) or managed PKI can be used to avoid the fraudulent manipulation of smart meters in large scale and advanced metering infrastructures (AMIs), thus securing data integrity, revenue streams and service continuity.
- The smart grid can be secured at the communication layer by implementing PKI directly into meters, enabling identification, verification, validation and authentication of connected meters for network access. PKIs are ideal for large-scale security deployments requiring a high level of security with minimal impact on performance. In a PKI environment, it is essential that private keys and certificates be guarded by a reliable management solution that protects against ever-evolving data threats.

The European Union (EU) has engaged in a number of initiatives in the critical infrastructure protection (CIP) space.

The Project CRISALIS (CRITICAL Infrastructure Security AnaLysis) was launched in June 2012. Its goal is to provide new methodologies to secure critical infrastructure environments from targeted attacks, deliver new tools to detect intrusions, and develop new techniques to analyse successful intrusions.

- **Intelligent transportation**

Keeping the city moving is critical. Transportation strategies have an impact on public safety, the environment, energy, emergency response services, the ability to do business, and on the delivery of other critical services, as well as the overall maintenance of the quality of life of citizens.

Real-time traffic flow information, coupled with telecommunications, global positioning systems (GPSs), machine-to-machine (M2M) communication, wireless fidelity (Wi-Fi) and RFID technologies, as well as data analytics and prediction techniques, can be used to enhance private and public travel. Sensors can collect information about traffic conditions at critical city spots and send this information, via wireless communication, to centralized control systems. This data can then influence decision-making or even operate processes like traffic light synchronization.

Optimizing transportation models requires a high degree of complexity from the ICT infrastructure and its components to avoid disruptions. These can be the result of malicious intent or simply well-meaning insiders' actions. For example, traffic management could be impaired by hacking into the navigation system that directs a bus driver into the city through a wrong route, due to false information about traffic volume.

**Recommendations**

- The data transmitted from devices may be subject to spoofing. Unencrypted traffic data may be subject to attackers injecting false traffic reports into satellite navigation devices, as proven by cybersecurity experts.
- Vulnerabilities can also put information at risk due to unintentional actions, mistakes, carelessness or inadequate processes.

### ■ **Connected health care**

Health care delivery can benefit from a connected approach, with electronic patient records available to all medical services. This will enable public health professionals and clinicians to collaboratively access information in a secure way, at any time, from anywhere and from any mobile device.

In many cases, telemedicine solutions connected through broadband, wireless or satellite, can prove vital in situations where the infrastructure or specific contingencies do not allow for the physical presence of a specialist, in cases such as natural disasters or remote geographical locations.

An ageing population needs traditional care, as well as assisted living and health monitoring services to enable independence at home. This can be achieved through the utilization of sensors and devices connected to health operators through broadband, wireless and data analytics, and crucially, the deployment of privacy, identification and security systems.

In the case of a road accident, a malicious intrusion that compromises communication between first respondents and operational centers could prevent its accurate localization and the efficient dispatch of emergency units. Equally, during such incidents, emergency services might need to operate using medical data for injured patients by accessing a central location, and they should operate on the basis of reliability and integrity of the information.

#### **Recommendations**

- In this context, back-up, cybersecurity and authentication solutions can ensure that health care systems offer reliability and integrity, as well as patient privacy.

### ■ **Public safety and security**

Above all, cities need to be safe. Public safety and security has become paramount for city administrations, whether protecting them against crime, natural disasters, accidents or terrorism.

From conventional street violence to complex financial offences, identity thefts or data breaches, the crime scenario is extremely dynamic and can only be tackled by increasingly sophisticated technologies and processes.

Telesurveillance systems are becoming pervasive in urban settings and, coupled with real-time communication capabilities, can help emergency services intervene promptly in incidents.

In the immediate aftermath of a serious accident or catastrophic event, reliability and security become key factors. The ability to share information between agencies, to operate sophisticated telesurveillance systems, to guarantee connectivity to incident response teams and first responders, to gather and analyse heterogeneous intelligence and data about incidents in real time, allow municipalities and emergency services to increase safety conditions for citizens, businesses, assets and infrastructure.

**Recommendations**

- It is critical that telesurveillance systems maintain their integrity and availability and that emergency services can rely on wireless or M2M communication to obtain directions and instructions from operational control centers.
- When information is transferred and managed over unsecured lines between different operators (both internal and external) and with heterogeneous systems, data encryption is required. By leveraging strong two-factor authentication and one-time password entry, only trusted personnel can gain access to critical data and control systems. Digital certificates can also be used for authentication, signing and encryption.

**Wireless communications and hotspots**

Both large and small municipalities offer free wireless hotspots in addition to those provided by airports, hotels, and shops. As this trend continues to grow, more and more citizens will be exposed to potential vulnerabilities, in particular the younger population who are at risk of being lured into unsafe websites and chat rooms.

Designing and building encryption solutions into devices ensures that they can only communicate with the required control center, and that communications can be authenticated.

Public WiFi connections (both free and paid) are increasingly common, but security for such connections may be lacking or is insufficient. WiFi connections can be provided in coffee shops, hotels, airports, parks and even in some streets. The host buys a wireless access point, connects that device to the Internet, and broadcasts its signal within a public place. Anyone with a wireless card within range of the host's access point can access its network and use the Internet. In order to make it quick and easy to use their hotspots, some hosts disable much of the security built into their wireless devices. This is a notable trade-off. Without encryption, your plain text data passes unprotected through the air, where it can be intercepted by cybercrooks.



**Recommendations**

- Attention should be paid to the surrounding area when accessing hotspots, in order to verify that nobody is able to read one's laptop screen. A privacy screen can be used for extra security.
- The network configuration should be changed in order to manually select each wireless network that the system joins.
- File sharing should be turned off while at a hotspot. Highly sensitive or personal data should be stored elsewhere, and when using instant messaging or e-mail, nothing should be sent that one would not want made public.
- There exist products that enable users to become “invisible” on the network by creating a virtual private network (VPN). These products encrypt the username, password and other confidential information that users may have entered online, allowing the users to control what they share online, no matter where they connect to the Internet. Internet banking, stock trading or other sensitive online financial transactions should be avoided while using a public hotspot.
- Security software should be kept current and active.

These Internet hotspots can be a virtual playground for beginning hackers or a potential gold mine for sophisticated veteran cybercriminals, as illustrated in Box 2.

**Box 2. How do cybercriminals exploit WiFi hotspots?**

Packet sniffers are programs that allow the interception of wireless transmissions via data packets. If the packets are unencrypted, someone with a packet sniffer can see information like personal communications, financial transactions and account passwords as plain text.

Wi-phishing, or The evil twin, is a process in which a cybercriminal pre-emptively hijacks the hotspot's wireless signal with one of his own, spoofs the legitimate network name, and replaces the sign-up page with one that looks like the real thing. As a result, credit card and other personal information can be supplied to the spoofer, rather than the hotspot provider.

- Firesheep is a free add-on application created for the Firefox browser that wraps a friendly interface around a hacker's tool, allowing cybercriminals to “side jack” or intercept login credentials for a site or service that does not require a secure socket layer (SSL) (a security feature that provides encryption).

It is critical that free Wi-Fi hotspots in SSC, whether provided by private entities like shops or by the city administration itself, are secured.

## 6 *SSC components and their vulnerabilities*

---

### ▪ **Network infrastructure**

The network infrastructure of SSC should ensure the safety and reliability of communication, including various network forms (e.g. cellular network, Internet, satellite network, government and enterprise intranets, among others). The vulnerabilities of these networks will be inherited by the network infrastructure of SSC and possibly amplified, given the additional complexity of the SSC architecture.

Vulnerabilities of the network infrastructure in SSC may be present in the following areas:

- There is wide variety of devices involved in a SSC network. A peak of network accesses in a short time might lead to network congestion, a situation favorable to potential attackers. In these cases, authentication and key generation mechanisms can produce further network resource consumption.
- Internet or next-generation Internet will be the core carrier of network infrastructure of SSC. Denial of service (DoS) and distributed denial of service (DDoS) attacks across the Internet still exist, hence the need to adopt more robust preventive measures and disaster recovery mechanisms, also taking into account the heterogeneity of technical equipment and their protection capabilities.
- The heterogeneity of the network architectures will produce additional vulnerabilities, particularly in network authentication.
- The separation of sensor networks and communication networks will create new security risks. Theft, tampering, counterfeiting information, can disrupt the communication between different types of the network.

### ▪ **Cloud computing facilities**

Due to the high concentration of users and information resources, the security consequences of cloud delivery are much higher than traditional delivery models. The security issues faced by cloud computing technology are as follows:

- **Data concentration security issues**
  - Cloud computing systems will affect the storage, processing and transmission of user data. If the privacy information is lost or stolen, the user could be seriously impacted. Cloud computing has introduced new types of security challenges, such as how to ensure the security of cloud service management and access control mechanisms inside the security provider, how to implement effective security audits, security monitoring for data manipulation, as well as how to avoid the potential risk of multi-user coexistence in a cloud computing environment.
- **Data availability in the cloud**
  - User data and business applications are hosted in the cloud computing system. Therefore, business processes are dependent on the service provider's general reliability, in terms of service continuity, service level agreement (SLA) and security policies, as well as user data protection and recovery in case of an incident.

### ▪ **Internet of Things**

IoT describes the capability of devices, provided with embedded sensors, to be connected via an IP address to the Internet, and exchange data with a remote system.

These capabilities can be exploited in SSC environments in the various disciplines identified so far, thus providing the ability to remotely control the components of the different systems.

With this ability come additional vulnerabilities: on one hand, in the shape of new doors for malicious attacks, and on the other, in terms of the significant amount of data generated while exchanging information or data that will need to be managed, stored and restored in case of an incident. Hence, this constitutes an additional area of potential concern in managing SSCs.

#### ▪ **Sensor network security**

Sensor information should be transmitted outside through one or more sensing nodes, called gateway nodes. Thus, the security of sensor network security should be considered.

Sensor nodes are deployed in unattended situations, for example, when node resources are severely limited it is difficult to adopt sophisticated security mechanisms, or when the node processing capacity is weak. Due to these features, the sensor nodes can pose security issues such as intermittent connection, vulnerability to capture, or false data being sent. In these cases, the traditional security mechanisms cannot be applied.

In these circumstances, the risks are as follows:

- a) If the sensor network gateway node is controlled by the attacker, it may lead to the loss of security in the sensor network, with subsequent uncontrolled access to the existing information through the gateway.
- b) If the ordinary sensor node is still controlled, but the key is leaked, the attacker could be able to gain control of the node in order to transmit some erroneous data.
- c) If the ordinary sensor node is controlled, but not the key, then the attacker can discriminate node functions, such as testing temperature, humidity, among others.

#### ▪ **Bottlenecks of radio frequency identification (RFID) security**

The characteristics of RFID include non-contact operation, long distance identification, and reading without visible light, among others. Due to its nature, RFID technology involves privacy risks. For example, information may be illegally collected and the location illegally tracked. Furthermore, RFID authentication should also be considered as part of the security strategies.

#### ▪ **Data**

##### ▪ **Embedding security with data to achieve confidentiality, integrity and authentication**

- SSC will need to manage a significant number of smart devices and associated data, together with identity and services across the entire supply chain. Thus, it will be important to secure smart endpoints and embedded systems in order to ensure these devices to avoid exposing to additional threat vectors and risk.
- Protecting data explosion, including real-time information, involves a sound management approach to storing, protecting, and backing-up, as well as archiving and retrieving data whenever needed.

##### ▪ **Data confidentiality issues**

- SSC systems can access, use and exchange sensitive personal information, which, if disclosed, could cause great harm to individuals. Typically, health care systems will include detailed medical history and other sensitive information closely related to the patient's life.

- Similarly, information on critical infrastructure like smart grids is highly sensitive, and if compromised or in the wrong hands, could endanger national security and economic interests.
- Identity theft, counterfeiting and forgery are other instances of data-related threats that could aim at different sorts of fraud, e.g. card cloning or license plate counterfeit.
- **Data availability issues**
  - A vast number of RFID and other IoT devices in SSC will involve potential issues with the traditional authentication systems. The massive presence of strict certification requirements can cause a severe impact on system efficiency, for example, when cross-domain access is needed, involving authentication systems.

## 7 Security architecture of SSC

---

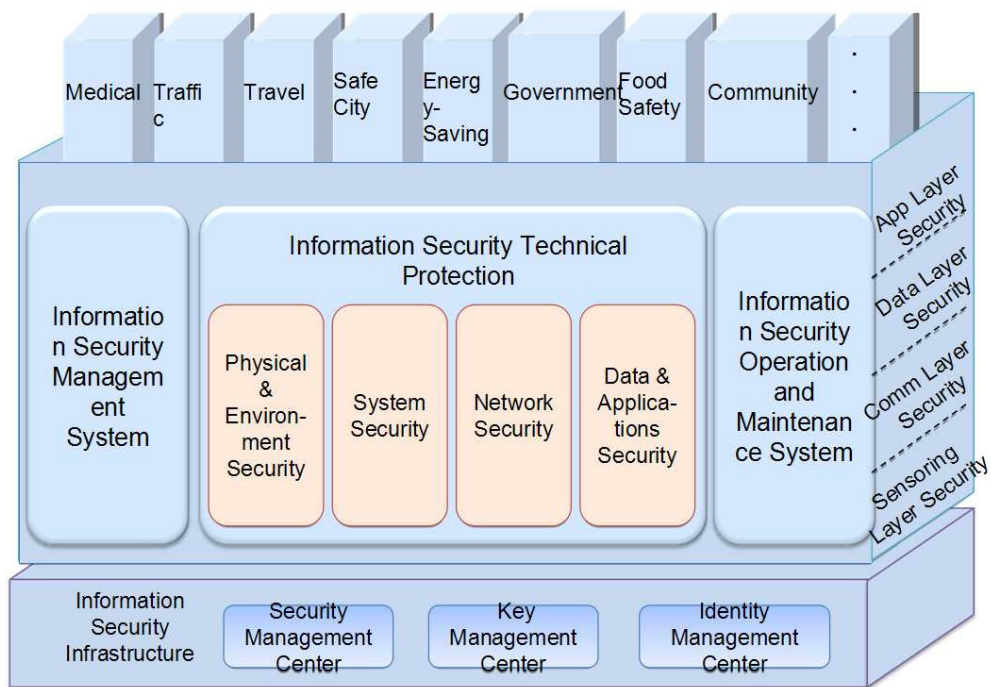
An information security system provides a security guard for a smart sustainable city both in terms of technology and management aspects. A sample architecture is presented in Figure 2, and includes the following main components:

- information security infrastructure;
- information security mechanism:
  - information security management system;
  - information security technical protection;
  - information security operation and maintenance system;
- security of applications (top section of Figure 2).

The information security infrastructure can include several centers, such as the security management center, the key management center and the identity management center.

A comprehensive security strategy should address the security risk at each of these layers (i.e. sensing layer, communication layer, data layer and application layer), in order to ensure a system-wide, all-encompassing protection for SSC from the multiple threats that can affect the optimal operation of its services.

This protection mechanism should also cover the various applications implemented in SSC (e.g. medical, traffic, travel).

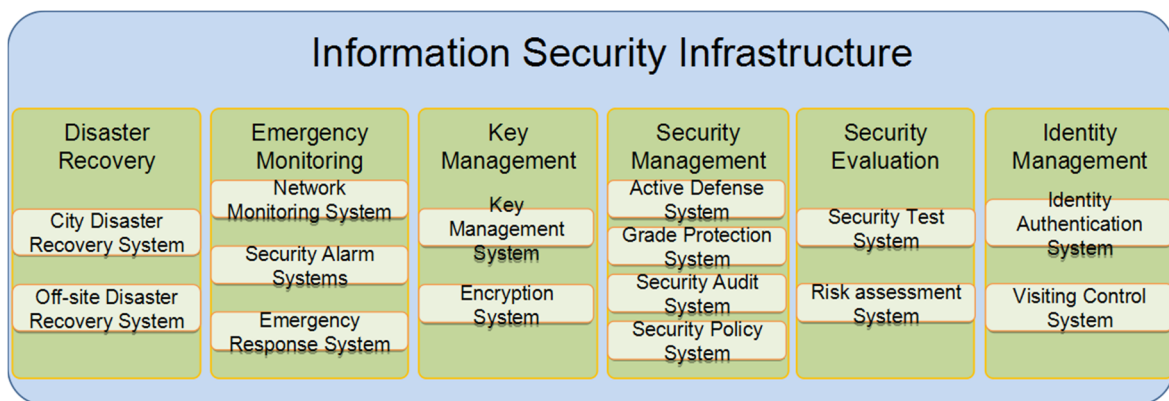


Source: FG-SSC deliverable, *Technical Report on overview of smart sustainable cities infrastructure*. Ibid.

**Figure 2 – Architecture of an information security system for SSC**

▪ **SSC information security infrastructure**

The information security infrastructure constitutes the technical foundation of the entire system, and as such, it provides a large number of security functions. The tasks of the information security infrastructure centers include disaster recovery, emergency monitoring, key management, security management, security evaluation and identity management (Figure 3).



Source: FG-SSC deliverable, *Technical Report on overview of smart sustainable cities infrastructure*. Ibid.

**Figure 3 – Information security infrastructure of SSC**

#### ▪ **SSC information security technical protection**

The core protection mechanism for SSC functions through a comprehensive security system that should be established in four directions, namely physical and environmental security, system security, network security, and data and application security on a technical level.

- Physical and environment security contains several aspects of environment security, equipment security, as well as disaster recovery and prevention.
- System security includes three main aspects: anti-virus technology, host security reinforcement, and operating system security.
- Network security involves gateway anti-virus, firewall, and intrusion detection.
- Data and applications security includes database encryption and database backup technologies, among others.

#### ▪ **SSC security of applications**

Within SSC environment, the security of various applications should be based on the information security mechanism that relies not only on technical protection security, but also on security management, security operation and maintenance aspects.

## **8 Cybersecurity and a SSC governance framework**

---

Traditional mechanisms to organize and coordinate efforts among city stakeholders may prove insufficient to achieve the goals of smart sustainable cities, and ultimately ensure a better quality of life to city dwellers, businesses and visitors facing the effects of increasing threats.

The need for interoperability of different smart systems and data sets generates the need for a unified approach to governance, to ICTs, and in particular, to cybersecurity and data protection mechanisms.

SSC stakeholders are faced by the need to ensure that the ICT approach and the related cyber-protection mechanisms are interwoven with the overall development strategy of the city. Chief Information Officers (CIOs) are becoming increasingly involved in devising these strategies, in collaboration with policy and decision-makers.

Each stakeholder, including system administrators, will have to consider the wider implications of security incidents, regardless of their nature. This involves considering how the recovering process could impact upon other components of the cities' services and operations.

Similarly, any subsequent adjustment aimed at addressing new system vulnerabilities will have to take into account the implications of those measures on any related system, both in terms of interoperability and cybersecurity.

A centralized governance body for SSC could utilize a central virtual dashboard, comprising the ICT operational center, to run the services provided by SSC and provide ongoing assessment and timely response to varying incidents and needs. With the reliability of SSC services at stake, absolute continuity, reliability and safety must be guaranteed.

Any threat to the security of the system and its information can be detected, analysed and dealt with using threat intelligence services. The deployed ICT should be able to obtain reliable threat and vulnerability intelligence, and consequently dynamically adjust its security stance. In the case of incidents, these need to be promptly and effectively managed by specialist operators and incident



management tools in order to ensure that services return to their normal operational status, and to minimize the disturbance caused to users.

Ultimately, modern cities compete with each other to attract businesses, talent, skills and taxpayers. As a result, administrations are increasingly valuing the role of innovation, technology, marketing and communication practices. In turn, private sector companies are attracted into cities by the ease of doing business – in terms of cost efficiency, infrastructure (e.g. office space, broadband, telecommunications, as well as utilities such as energy, water and transportation), and general quality of life for their staff (e.g. residential, health care and educational systems).

The adoption of effective governance structures as part of SSC strategies is closely linked to the effectiveness of cybersecurity measures. It is vital to ensure adequate preparedness and operational efficiency, as well as to take advantage of opportunities, address emerging needs, and overcome the security challenges faced by smart sustainable cities. Further information on SSC governance can be found in the FG-SSC Technical Report on “Engaging stakeholders for smart sustainable cities”<sup>9</sup>.

## 9 Recommendations to ensure SSC service continuity

---

Smart sustainable cities should prioritize providers who offer solutions and methodologies for security, backup, data loss prevention, archiving and disaster recovery, and who are able to protect and manage heterogeneous environments resulting from legacy systems and newer deployments, including open source, managed mobile devices, and virtualized systems.

### ▪ Protecting information proactively

SSC contexts increasingly involve big data considerations, and subsequently the need to centralize and manage the vast amount of information that is continuously generated and used. Taking an information-centric approach, embedding security within data and taking a content-aware approach to protecting information, is vital for identifying ownership of: (a) the location of sensitive information, and (b) who has access to it. Classifying data and utilizing encryption helps to secure sensitive information and to restrict access to unauthorized individuals.

### ▪ Authenticating users

Strong authentication enables organizations to protect public assets by verifying the true identity of a smart device, system or application. This prevents individuals from accidentally disclosing credentials to an attack site, and from attaching unauthorized devices to the infrastructure.

### ▪ Leveraging threat intelligence

In order to understand the major attack trends, city officials and CIOs can count on an established observatory, like the Global Intelligence Network, to provide one of the most extensive and accurate vendor-neutral analyses of trends on malware, security threats and vulnerabilities from security research centers around the world. The same information is also used to compile the annual Internet Security Threat Report, which contains vital information about current and emerging threats and vulnerabilities.

---

<sup>9</sup> FG-SSC deliverable, *Technical Report on engaging stakeholders for smart sustainable cities*. Available at: <http://www.itu.int/en/ITU-T/focusgroups/ssc/Pages/default.aspx>

- **Balancing traditional versus cloud delivery**

Within a SSC environment, all the smart services mentioned so far in the analysis can be delivered through a traditional client-server approach, but also through a cloud computing model, both private and hybrid, in order to leverage “as-a-service” capabilities and efficiencies.

These models require a secure virtualized environment where data can be safely guarded and processed with appropriate service level agreements (SLAs) in order to guarantee the provision of essential services to citizens. Authentication and encryption policies and techniques can help ensure the integrity of the cloud environment and its safe operation in the virtual space. Availability and disaster recovery solutions should guarantee compliance with SLAs, as well as resilience for critical city services.

- **Managing security services and Computer Emergency Response Teams (CERTs)**

SSC should also consider outsourcing security services to providers who can leverage extensive, global expertise in the field of cybersecurity to minimize security-related disruptions and data loss. The ICT leadership can then be relieved from this particular complex and time-consuming aspect and focus on the functional duties of running the city's ICT.

SSC should also rely on their national CERTs to align with national coordination on cyber incidents and security, and thus benefit from the international visibility this type of coordinated efforts provide.

- **Protecting infrastructure**

Securing endpoints, messaging and web environments, defending critical internal servers and implementing the backup and recovery of data, should be among the key priorities of SSC strategists. Organizations also need visibility and security intelligence to respond to threats rapidly.

- **24x7 availability of the critical infrastructure**

Ensuring resilience in case of an incident can be achieved through the adoption of solid backup and recovery software or appliances, as well as adequate policies, processes and tools.

- **Developing an information management strategy**

This should include an information retention plan and policies. Organizations need to refrain from using backup for archiving and legal retention, and should instead implement deduplication mechanisms to free up resources, adopt a full-featured archive system, and deploy data loss prevention technologies.

- **Access control at the boundary of network**

Access control at the boundary can isolate attacks away from internal networks. Different boundaries can be implemented, with different policies enforced.

A firewall that consists of access rule, verification tools, packet filtering and application gateway, can greatly improve the security of an internal network. Since only selected protocols can pass through the firewall, the network environment has become more secure. Firewall can prevent well-known unsafe protocols, making it impossible for external attackers to use these vulnerabilities to attack the internal network. The firewall should be able to reject all of the above types of attack packets, and immediately alert the administrator.

In the firewall-centered security environment, all security measures (e.g. passwords, encryption, authentication and auditing, among others) can be configured on the firewall. This approach is more cost-effective than a decentralized network security mode.

If all network accesses go through the firewall, this can record and make a log of these visits, and also provide statistical data of network usage. When suspicious actions occur, the firewall can then generate the appropriate alarm, and provide detailed information about the incident for threat analysis purposes.

- **Protecting intrusion dynamically**

Intrusion detection is another important dynamic security technology, which can collect and analyze information from a number of key points of computer network and system, and find out whether there is any suspicious behavior, sign of an attack or policy violation. There are three types of intrusion detection systems (IDSs):

- (a) network-based IDS;
- (b) host-based IDS;
- (c) integrated IDS.

- **Preventing DDoS attacks**

There are different mechanisms that can enhance the ability to withstand DDoS through increasing the cost of attack. These include the use of high-performance network equipment, the guarantee of sufficient network bandwidth, the upgrade of the host server hardware, the use of static pages whenever possible, the enhancement of the operating system transmission control protocol (TCP)/IP stack, and the installation of specialized anti-DDoS firewall.

- **Network security audit**

A network security audit carries out compliance management by fine-grained auditing the network operating behavior of the business environment. Through recording, analyzing, and reporting the network behavior of system and authorized users, the network security audit can function as a mechanism for planning and preventing, concurrently monitoring, as well as reporting and tracking the source after the incidents take place. Consequently, network security audits can strengthen the internal and external networks behavioural regulation.

- **Child online protection in SSC**

As the analysis conducted thus far has demonstrated, the design of a comprehensive cybersecurity strategy for SSC should take into account multiple sources of vulnerabilities, as well as existing and emerging threats. Children are among the most vulnerable users of online services. As identified by the ITU-T Joint Coordination Activity on Child Online Protection (ITU-T JCA-COP):

*"Child online protection covers a number of issues, and is being addressed at national, regional and international levels, across a myriad of environments, including social and legal. At the international level, and within the ITU, the Council Working Group on Child Online Protection has received much information on national activities, and has developed guidelines, and the Joint Coordination Activity on Child Online Protection has identified many technical activities that are contributing to the safety of children on line at a global level."(ITU-T JCA-COP)*

Further details about child online protection can be found in the reports produced by the ITU-T JCA-COP, at <http://www.itu.int/en/ITU-T/jca/COP/Pages/default.aspx>.

## 10 Conclusions

---

Smart sustainable cities are emerging around the globe, with numerous examples of initiatives fostered by local, national and transnational governments and various institutions.

Consequently, local administrators and policy makers will be increasingly driven to make their cities more competitive in order to attract businesses, talent and taxpayers, as well as to comply with sustainable policies, including greenhouse gas emission targets and carbon footprint guidelines.

SSC deployments will involve multifaceted developments carried out by a diverse ecosystem of providers in innovative domains, as well as the adoption of state-of-the-art technologies characterized by critical and complex ICT implementations.

However, the rise in ICT complexity has also translated into increasing levels of vulnerability, both to malicious attacks and to unintentional incidents.

The analysis conducted in this Technical Report has explored how leadership and governance are key drivers, as well as essential conditions to ensure cyber resilience and service resilience within smart sustainable cities.

Protecting both the systems and the data with rigorous policies, up-to-date technology and techniques, will prove vital in ensuring the continuity and the resilience of all the services involved in the SSC architecture.

Only by conceiving interconnected urban systems with security and information protection in mind, SSC administrators will be able to ensure the safety and the well-being for citizens and businesses alike.

Security threats and defensive strategies are now an integral part of the discussion in the policy making boardrooms, as much as they are in the private sector. Public administrators know that any serious incident or breach could result in devastating outcomes in terms of financial, data, credibility and reputation loss. Thus, city planners and administrators should take proactive steps to ensure systems' security and data protection from the early stages of the SSC's inception and planning process. This constitutes a crucial step towards building resilient, smart sustainable cities for the twenty-first century.

## Abbreviations

This Technical Report uses the following abbreviations:

3G	Third Generation mobile networks
4G	Fourth Generation mobile networks
AMI	Advanced Metering Infrastructure
CERT	Computer Emergency Response Teams
CIO	Chief Information Officer
CIP	Critical Infrastructure Protection
CRISALIS	CRITICAL Infrastructure Security AnaLysis
DoS	Denial of Service
DDoS	Distributed Denial of Service
DSL	Digital Subscriber Line
EC	European Commission
ENISA	European Network and Information Security Agency
EU	European Union
FTTx	Fiber to the X (B – Building, Business; H – Home; C – Cabinet, Curb)
GPS	Global Positioning System
GRC	Governance, Risk and Compliance
HDTV	High-Definition Television
ICS	Industrial Control System
ICT	Information and Communication Technology
IDS	Intrusion Detection System
IoT	Internet of Things
IP	Internet Protocol
IPTV	Interactive Personality Television
IT	Information Technology
M2M	Machine-to-Machine
NFC	Near Field Communication
PII	Personally Identifiable Information
PKI	Public Key Infrastructure
RFID	Radio Frequency Identification
SAW	Surface Acoustic Wave
SCADA	Supervisory Control and Data Acquisition
SG	Study Group

SLA	Service Level Agreement
SSC	Smart Sustainable Cities
SSL	Secure Socket Layer
TCP	Transmission Control Protocol
UNFPA	United Nations Population Fund
VPN	Virtual Private Network
WEF	World Economic Forum
WiFi	Wireless Fidelity



## Bibliography

- FG-SSC deliverable, *Technical Report on anonymization infrastructure and open data for smart sustainable cities*. Available at <http://www.itu.int/en/ITU-T/focusgroups/ssc/Pages/default.aspx>
- FG-SSC deliverable, *Technical Report on engaging stakeholders for smart sustainable cities*. Available at: <http://www.itu.int/en/ITU-T/focusgroups/ssc/Pages/default.aspx>
- FG-SSC deliverable, *Technical Report on overview of smart sustainable cities infrastructure*. Available at <http://www.itu.int/en/ITU-T/focusgroups/ssc/Pages/default.aspx>
- Ospina, A.V., Bueti, C., Dickerson, K., and Faulkner, D. (2013), *Resilient Pathways: The Adaptation of the ICT Sector to Climate Change*, International Telecommunication Union (ITU), Geneva, Switzerland. Available at: [http://www.itu.int/en/ITU-T/climatechange/Documents/Publications/Resilient\\_Pathways-E.PDF](http://www.itu.int/en/ITU-T/climatechange/Documents/Publications/Resilient_Pathways-E.PDF)
- Recommendations ITU-T X.1500 series (2011-2015). Available at: <http://www.itu.int/ITU-T/recommendations/index.aspx?ser=X>
- Symantec (2014), *Internet security threat report 2014 – Volume 19*. Available at: [http://www.symantec.com/content/en/us/enterprise/other\\_resources/b-istr\\_main\\_report\\_v19\\_21291018.en-us.pdf](http://www.symantec.com/content/en/us/enterprise/other_resources/b-istr_main_report_v19_21291018.en-us.pdf)
- UNFPA (2007), *State of the World Population 2007: Unleashing the Potential of Urban Growth*, United Nations Population Fund (UNFPA). Available at: <http://www.unfpa.org/swp/2007/english/introduction.html>













# 3.5

## Intelligent sustainable buildings for smart sustainable cities

Technical Report

## Acknowledgements

This Technical Report was developed and authored by John Smiciklas (BOMA Canada), Frank Spitzer (IBI Group), Alec Hay (University of Toronto), Rosa Delgado (World Trade Center Association) and Sekhar Kondepudi (National University of Singapore).

Additional information and materials relating to this Technical Report can be found at: [www.itu.int/itu-t/climatechange](http://www.itu.int/itu-t/climatechange). If you would like to provide any additional information, please contact Cristina Bueti at [tsbsg5@itu.int](mailto:tsbsg5@itu.int).

## Table of Contents

		Page
<b>1</b>	<b>Intelligent sustainable buildings .....</b>	<b>459</b>
	1.1 Introduction.....	459
	1.2 The fourth utility.....	460
	1.3 Access control and security systems .....	460
	1.4 Elevators and escalators.....	461
	1.5 Lighting .....	461
	1.6 Signage.....	461
	1.7 Building condition monitoring.....	462
	1.8 Underlying philosophy.....	463
	1.9 Standards, codes and initiatives.....	464
<b>2</b>	<b>Intelligent sustainable building roadmap.....</b>	<b>465</b>
	2.1 Subjective versus objective evaluation .....	465
	2.2 Buildings versus Community .....	466
	2.3 Technologies.....	467
<b>3</b>	<b>Types of buildings.....</b>	<b>468</b>
	3.1 Single family.....	468
	3.2 Residential multi-unit .....	469
	3.3 Commercial buildings .....	469
	3.4 Hotel .....	469
	3.5 Hospital.....	470
	3.6 Factory .....	470
	3.7 Intelligent buildings and new business opportunities .....	470
<b>4</b>	<b>Other aspects .....</b>	<b>471</b>
	4.1 Operating costs and occupant comfort.....	471
	4.2 Tenants' satisfaction.....	471
	4.3 Maintenance.....	471
	4.4 Evaluation – How Intelligent is an "Intelligent" building?.....	473
	4.5 New business opportunities for the building sector and ICT industry.....	473
<b>5</b>	<b>Climate change adaptation.....</b>	<b>474</b>
<b>6</b>	<b>Examples of Intelligent buildings .....</b>	<b>475</b>
	6.1 Molson Center .....	475
	6.2 Terminal Windsor .....	476
	6.3 Flint Mass Transportation Authority Downtown Terminus .....	476
	6.4 Wellesley Long Term Care .....	477



	<b>Page</b>
6.5 World Trade Centers .....	478
6.6 Microsoft Headquarters Pilot Building .....	478
6.7 Infosys Building, Pocharam campus in Hyderabad .....	480
6.8 San Francisco Public Utilities Commission (SFPUC) Building.....	481
<b>7 Typical systems in an Intelligent Building.....</b>	<b>482</b>
7.1 Physical Infrastructure.....	483
7.2 Data and ICT Infrastructure .....	483
7.3 Building Control Systems.....	486
7.4 Integrated Building Management Systems .....	489
<b>8 Conclusions .....</b>	<b>492</b>
8.1 Vision .....	492
8.2 Future Considerations .....	492
<b>Abbreviations.....</b>	<b>494</b>
<b>Bibliography .....</b>	<b>495</b>

## Intelligent sustainable buildings for smart sustainable cities

### Executive Summary

The implementation of intelligent and sustainable buildings is also a key step in the journey to smart sustainable cities. To understand the scale of the issue, buildings are responsible for 40% of global annual energy consumption and up to 30% of all global energy-related greenhouse gas (GHG) emissions. Also on a global basis, the building sector is responsible for one-third of humanity's resource consumption, including 12% of all fresh-water use, and produces up to 40% of our solid waste. As buildings become more intelligent and more sustainable, there exists the possibility to reduce this impact dramatically.

The concept of “intelligent buildings” has been around for a number of years and has relied on the ability of individual systems within the buildings to communicate, to integrate and to perform in a manner allowing for numerous, complex, controls to generate a much-enhanced response to many kinds of stimuli. Thus, the argument of intelligence can reasonably be associated with the ability of intelligent buildings to function in an enhanced manner yielding many benefits for the occupants, the operators, the owners and reducing the overall environment impact.

Definitions of intelligent buildings have been proposed by different user groups and have also evolved during the last few years. Some view the ultimate benefits of intelligence to be the provision of a more efficient and effective working environment for the occupants while others define such intelligence as providing greater economics for the building operators. However, some others conclude that automated responses, in particular to security and emergency situations, are of particular importance.

The thesis of intelligent buildings, therefore, is that base building systems can be designed in a manner which permits their intercommunication and which also allows for communication between the building and individual tenant. The benefits are not always the same for each group of interested parties, nor are all the benefits evident when not all buildings include the same features.

Intelligent building technologies open the opportunity to facilitate the monitoring of a building's overall condition. Transducers and sensors are available to measure most building related parameters and in any given situation there may be particular needs driving their specific use.

The significant advantage of intelligent buildings is that they can constantly monitor current operations in context and automatically adjust resources for optimum efficiency while identifying and accurately informing key decisions in a timely manner. It is the optimization of efficiency that will lead to reduced environmental impact and a more sustainable built environment.

It is also evident that the standards applicable to the provision of an IP infrastructure are one possible mechanism by which an intelligent building can be implemented. Depending on the jurisdiction, there may be a need that some of the systems require special considerations in order to comply with all aspects of the building code (e.g., fire safety code or electrical code).

Objectives of intelligent buildings have been described in general terms but nevertheless there are often strenuous professional arguments as to what should be the primary objectives of an intelligent building. Is it more important that the building be more efficient, i.e. that the operating costs are reduced or, is it more important that the effectiveness of individual occupants in the building are put as the most important objective.

Depending on the particular structure, its purpose, the technologies which are prevalent in the building, and other factors, there will often be different objectives. With ever rising energy and labour costs it is obvious that if those costs can be kept in check, or preferably reduced, opportunities for financial savings will provide an immediate return on any extra investment of building an intelligent building. A building which is operated continuously e.g., a hospital, or which is operated by individuals who pay fees such as condominiums are less likely to see immediate benefits from the functions available in intelligent buildings.

Many modern buildings today have HVAC, lighting, security, communication systems that use ICT networks for management and control. This can provide the foundation to develop intelligent building. It is therefore possible to implement policies that enhance building efficiency and effectiveness consistent with changing business requirements and user needs.

In addition, climate change related severe weather events are increasing in frequency and severity. These severe weather events include: urban floods, extended heat waves, ice storms, extended cold spells, high winds / tornadoes / hurricanes.

These weather events have both a long term and short impact on the building infrastructure in cities. During short-term events, building infrastructure is impacted by: major structural damage, damage to a building's support and utility systems, closure and loss of revenue among other items. Over the long term, severe weather and more extreme temperatures lead to accelerated degradation of a building's envelope, utility systems and infrastructure.

Steps need to be taken to maintain the building's exterior and envelope to prevent damage to the building and its' equipment. At the same time, the design and intelligent infrastructure of the intelligent building can assist with minimizing the effects of extreme events.

# 1 *Intelligent sustainable buildings*

---

## 1.1 Introduction

Cities cannot become smart and sustainable unless the issue of the built environment and in particular buildings are addressed. On a global basis, buildings are responsible for 40% of global annual energy consumption and up to 30% of all global energy-related greenhouse gas (GHG) emissions. Also on a global basis, the building sector is responsible for one-third of humanity's resource consumption, including 12% of all fresh-water use, and produces up to 40% of our solid waste. Source (UN-Habitat 2013). In order to address the issue of climate change through the reduction of GHG emission the impact of buildings must be reduced. It is therefore important for buildings to become more intelligent and more sustainable to reduce this environmental impact dramatically.

The concept of a "smart" or "intelligent" building may seem to be an oxymoron. Intelligence is normally indicative of a human (or animal) attribute in which individuals are capable of making interpretations, deductions or inductions, related to observations and to stimuli. Some great individuals, such as Einstein, have been described as extraordinarily "smart" or intelligent" and so it may seem that making these associations with inanimate objects such as buildings is, at first glance, an inappropriate association.

The concept of "intelligent buildings" has been around for a number of years and has relied on the ability of individual systems within the buildings to communicate, to integrate and to perform in a manner allowing for numerous, complex, controls to generate a much-enhanced response to many kinds of stimuli. Thus, the argument of intelligence can reasonably be associated with the ability of these buildings to function in an enhanced manner yielding many benefits for the occupants, the operators and the owners. This report will provide a number of examples of "intelligent buildings", while describing the benefits and efficiencies generated by such integration.

Definitions of intelligent buildings have been proposed by different user groups and have also evolved during the last few years. Some view the ultimate benefits of intelligence to be the provision of a more efficient and effective working environment for the occupants, while others define such intelligence as providing greater economics for the building operators and yet some others conclude that automated responses, in particular to security and emergency situations, are of particular importance.

The following definitions for intelligent buildings should be considered:

- The use of integrated technological building systems, communications and controls to create a building and its infrastructure which provides the owner, operator and occupant with an environment which is flexible, effective, comfortable and secure;
- Use of technology and process to create a building that is safer and more productive for its occupants and more operationally efficient for its owners;
- A building in which, those responsible for its operation, those benefiting from its operation and those ultimately responsible for the safety of all its occupants can share a view, and a vision of the building status at all times.

- "Smart" buildings should take advantage of dynamics, characteristics of building shell and HVAC system, automation, communications, and data analysis technologies in order to operate in the most cost-effective manner<sup>1</sup>.

Clearly, these definitions are not very different. Additionally, these definitions require an understanding of the building's systems and their abilities to interact with each other.

## 1.2 The fourth utility

Traditionally building structures, all around the world, are built in accordance with similar principles in which individual specifications and typically vendors, devise and implement operational components of the building in a manner, which is often described as "the three utilities." In traditional buildings, these three utilities are electrical, mechanical and plumbing, which are integrated with the base building. In such traditional constructions, the tenants become responsible with respect to a variety of different plans to implement their "tenant improvements" which are fed from the three utilities, which have been integrated with the building.

Notably, communications are traditionally omitted from the base building services and it is the responsibility of the base building utility providers to install any communication services necessary for the provision of those utilities. As examples, the reader should consider elevators, which clearly include significant communications requirements dedicated to the elevator, and which are an independent installation used exclusively for this one application. The communications requirements for the heating, ventilating and air conditioning (HVAC) mechanical systems, monitoring of electrical usage and potentially other systems are equally repetitive, isolated and not able to promote or address the abilities for these systems to become a true basis for any form of intelligence.

The thesis of intelligent buildings, therefore, is that base building systems shall be designed in a manner which permits their intercommunication and which also allows for communication between the building and individual tenant. The benefits are not always the same for each group of interested parties, nor are all the benefits evident when not all buildings include all the same features. This report has described some buildings in which such systems have been employed and which have, in most cases, functioned successfully for a number of years, allowing for many parties to enjoy some of the benefits.

Consider some of the following examples of the benefits and opportunities which these intercommunications, or intelligence, can provide.

## 1.3 Access control and security systems

The access control system should be integrated with the fire system, lighting system and the HVAC system. With these forms of integration, the system "intelligence" can allow a user to enter the building and the information that this user has presented in terms of his credentials will be signalled to a number of independent systems. As a result, when the user approaches his/her workspace, the lighting, HVAC controls (and potentially other systems) can each have been adjusted to meet that user's preferences. In the hotel industry, for example, empty rooms are normally not ventilated or lit so as to reduce energy usage. When the room is "rented", the necessary adjustments can be made long before the new occupant reaches his/her temporary front door.

---

<sup>1</sup> ASHRAE, The American Society for Heating, Refrigerating and Air-Conditioning Engineers as part of their Technical Committee 7.5 (<http://tc75.ashraetcs.org/>)

When the fire alarm notifies the access control system of an emergency, provision can be made that no unauthorized individuals can enter the building while everybody who is already in the building can exit without constraint. Alarms caused by magnetic locks which have been released owing to the fire alarm, will be ignored, and lights throughout the building can be automatically energized so that first responders are not faced with a situation wherein they looking for the light switches.

## 1.4 Elevators and escalators

Through suitable programming, the number of elevators being used at any one time can be optimized to address schedules, loads and potentially, emergencies; e.g., if paramedics require an elevator, it can be automatically configured to provide exclusive use for such purposes under an emergency situation. There are many advances in elevator programming which have been pioneered by some of the large elevator manufacturers, e.g., provision of call buttons on the main entrance floor which allow random selection of elevators which will provide express rides to the floors identified by each individual's access credentials. Thus, different users going to the same floor will all be channelled into a common elevator cab, which will then go directly to that, or those, selected floors. The primary benefit as a result of this intelligence will be the ability to use fewer elevator cabs, i.e., lower energy costs and provide a faster service.

## 1.5 Lighting

The traditional large office buildings in which light switches are "hidden" are probably a thing of the past. The current trend to individually controlled lights, with the ability for each individual user to select their preferred lighting levels, is potentially a significant power saver and the use of more modern lighting technologies also reduces the amount of heat generated by more efficient luminaires. These trends can be integrated with many additional benefits, some of which have been noted in the foregoing comments; e.g., when an individual arrives, the lights in that person's area may be illuminated. When the individual goes home, the lights will be extinguished. In an emergency, activation of all lights will enhance the ability for responders to attend to any situation without themselves having to activate any lights.

Furthermore, the use of automated lighting controls allows an evaluation of the lighting utilization so that any re-lamping procedures can be scheduled based on actual hours of usage, and not based on calendar activities. Such lighting systems also permit potential charge backs from the building owners to the tenants based on the actual electricity used. The system can monitor any lights which have failed and which can automatically be reported to those responsible for maintenance.

Needless to say, the addition of such intelligence will also identify room occupancy and allow for the measurement of lighting levels and the automated compensation of lighting settings as a result of daylight shining in through windows or skylights (daylight harvesting). Automated blinds can also be used to adjust lighting levels to the desired value. It can be noted that electrical switch manufacturers have all brought very economical, motion activated light switches to the market, thereby allowing for some measure of intelligence in the simplest of applications.

## 1.6 Signage

There have been evident changes applicable to signage technology. Signage can readily be shown on screens, and include any required graphics thereby ensuring that language and situational variations are readily addressed. Thus standard signage can carry routine messages including hours of operation or the length of line-ups or delays. Such signs already appear in large buildings such as hospitals, universities and museums. The public is surrounded by these "computerised" signs in



transportation systems, such as airports, highways, police checkpoints or customs applications. Nobody thinks twice about the information presented on luggage carousels at airports, which change continuously (and are not always 100% accurate) and the concept of having time-dependent signage or situation-dependent signage does not come as a surprise. Thus, particularly in Europe, where great emphasis is placed on visitors to buildings being well-informed upon arrival, of how they may need to exit if an emergency arises, automated signage is widespread. For example, electronic signage can be changed in an instant, should a building evacuation be necessary, so as to point out the emergency stairs as opposed to the elevators.

## 1.7 Building condition monitoring

Intelligent building technologies open the opportunity to facilitate the monitoring of a building's condition. Transducers and sensors are available to measure most building related parameters and in any given situation, there may be particular needs driving their specific use. Under appropriate conditions some or all of the following may be appropriate and would then be communicated to a central monitoring facility.

- Areas with heavy snowfalls or other weather extremes may wish to monitor snow load or wind load on roofs;
- Exhibition halls or bridges may wish to monitor key structural components affected by wind loads, suspension of exhibits, loudspeakers (in musical performance facilities);
- Moisture detectors can be laid beneath membranes protecting roofs (especially green roofs which are now mandated in many cities) or bridges;
- Monitoring the temperatures of electrical panels, switch gear and transformers;
- Metering current flow in electrical conductors;
- Providing sub-metering for tenants;
- Monitoring oil condition in bearings, transmissions, etc.;
- Monitoring pressure drop across filters, etc.;
- Measuring hours of usage of many components, such as filters, belts, lamps, pumps; and
- Routine testing of critical devices such as pumps, loudspeakers, alarms etc.

No further comment needs to be made with respect to some disasters which have occurred and which might have been prevented in the event that some or all of the building monitoring technologies alluded to above might have been in place.

Clearly it can be added that these concepts are consistent with measuring and monitoring practices which have evolved dramatically within recent years.

## 1.8 Underlying philosophy

The preceding exams are comparatively superficial with the potential of intelligent building concept providing far greater benefits. The single spine is usually represented by physical security information management (PSIM). The significant advantage of intelligent buildings is that they can constantly monitor current operations in context and automatically adjust resources for optimum efficiency while identifying and accurately informing key decisions in a timely manner. This can range from the routine such as variance to the preventative maintenance schedules to automated restocking and repair according to changes in the normal pattern of use.

For example, Canadian Forces Station (CFS) Alert is the most northerly, permanently inhabited location in the world, located only 817 kilometres from the geographic North Pole. CFS Eureka is a intelligent building that advises the Canadian Department of Defense Headquarters in Ottawa, Canada when it is in use and automatically compiles its resupply and repair requirements for each season deployment to the High Arctic. The expectation is that it will in the future inform and enable change of use capabilities, enhancing through life value.



**Figure 1 – Canadian Forces Station Alert**

Photo credit: courtesy of IBI Group

Thus, the most important components for the purposes of providing an intelligent building are:

- A diverse, reliable, accessible communication system;
- Use of devices and systems which adhere to communication standards which provide bi-directional signalling;
- A clear commitment by the building owners, operators and designers to work together in order to ensure the provision of the opportunities for the exploitation of communications infrastructure and;
- Recognition of the roles played by each of those participating in the design, implementation, operation and maintenance of these systems.

The benefits which accrue to the building have been briefly described and may be summarized by:

- A more efficient building;
- Implementation of communications as a "fourth utility" which results in only one communications backbone for all applications (in some jurisdictions, fire or other life safety systems may need to be segregated into an additional communications infrastructure to comply with local ordinances) and;
- Energy savings, maintenance savings and staffing savings will generally arise as an indirect benefit of each of the individual efficiencies.

## 1.9 Standards, codes and initiatives

Communications standards are well documented in many environments. For the purpose of the systems contributing to a building, there have been various initiatives. Different manufacturers have all promoted proprietary solutions at different times, leading to incompatibilities and non-standardized solutions. If the communication infrastructure is built in accordance with recognized standards, the interfaces developed by other industries generally become applicable. These approaches have allowed the development of niche solutions, all of which operate using standards such as:

- RS 232;
- RS 485;
- Ethernet-TCP/IP;
- BACnet;
- LONworks.

Interfaces for each of these communications protocols are well-defined. As a result, an infrastructure capable of reaching all parts of any building, can readily be provided and can interface with each of the building's systems.

Typically, most of the communication requirements are interpreted as different layers in the "OSI 7-Layer Communication Model" (Open System Interconnection).

Using the approach of the OSI layers, it is possible for proprietary communications to be carried over a common and shared backbone. This common shared backbone, or communication highway, can easily be made redundant allowing for numerous components to automatically fail over to alternative devices, thereby ensuring that the building systems are not at risk of losing their integrity.

The concept of using a digital IP backbone, which can interface to almost any control or monitoring system has gradually become pervasive. Solutions carried over IP networks are sometimes well-publicized and at other times well-hidden from the public. Examples of systems which are readily compatible with an IP backbone include:

- Audio paging;
- Fire alarm systems;
- Telephone systems;
- HVAC systems;
- Surveillance systems;
- Access control and intrusion alarms;
- Lighting control systems;
- Elevator control systems;
- HVAC systems.

Based on these systems and others, each of which have the ability to communicate over this common backbone, it is evident that the standards applicable to the provision of an IP infrastructure are one possible mechanism by which an intelligent building can be implemented. Depending on the jurisdiction, there may be a need that some of the systems require special considerations in order to comply with all aspects of the building code, fire safety code or electrical code. The discussion in this document will not address any constraints imposed by such regulations. However, it does provide an assurance that there are solutions which are available for all requirements.

## 2 Intelligent sustainable building roadmap

---

Cars are very heavily integrated with alarms and information messages all displayed through a single driver interface which may inform the driver of issues related to tire pressure, bulbs which have failed, engine performance issues and many other components.

Current generation airplanes are all designed to operate using "fly by wire" meaning that communications for all of the operational aspects of the aircraft are carried over one or more communication backbones in a manner not dissimilar to that being advocated for an intelligent building.

The difference between these two examples and the building industry is however the legislative requirements for reliability, safety, and accountability which do not apply in the same manner in the heavily divided building industry.

Many of the concepts which have been described briefly in this document may be found in documents such as the Technology Roadmap adopted by Industry Canada and subsequently updated and reissued through Continental Automated Building Association (CABA) which has been a market driver in the development of industry discussion and cooperation related to intelligent building technologies.

### 2.1 Subjective versus objective evaluation

The objectives of intelligent buildings have been described in general terms but nevertheless there are often strenuous professional arguments as to what should be the primary objectives of an intelligent building. For example:

- Is it more important that the building be more efficient, i.e., that the operating costs are reduced?
- Or, is it more important that the effectiveness of individual occupants in the building are put as the most important objective.

Depending on the particular structure, its purpose, the technologies that are prevalent in the building, and other factors, there will often be different objectives. With ever rising energy and labour costs it is obvious that if those costs can be kept in check, or preferably reduced, opportunities for financial savings will provide an immediate return on any extra investment of building an intelligent building. A building which is operated continuously e.g., a hospital, or which is operated by individuals who pay fees such as condominiums are less likely to see immediate benefits from the functions available in intelligent buildings.

By contrast when the building is one which should respond rapidly to dramatic changes, clearly the intelligent building will respond more effectively.

The other significant component in deciding the evaluation and benefits of intelligence relates to whether the building is occupied by a consistent population such as in a residential building or whether the building is occupied by an itinerant population such as a sports arena, a concert hall, or even a hospital. In the latter example, the occupancy and therefore the building operating mode will change dramatically depending on whether there is an activity currently in progress or whether the activity is one which is not in progress.

The labour components required to monitor and manage a building are clearly dramatically reduced when the building network allows a single console to monitor all aspects of the building while fully meeting all of the requirements which may be applicable for monitoring of HVAC, fire and security considerations.

One evaluation tool which was developed some years ago and which is currently undergoing revisions is the building intelligence quotient (BIQ) Tool. The BIQ was developed on the assumption that communications is the dominant characteristic of any intelligent building.

The emphasis on communications however, which is prevalent in the original BIQ, seems to disregard some of the economic benefits available as a result of a more efficient building. Options such as the ability to select the least expensive fuel or to generate local power will, for example, have a significant impact on the bottom line costs of running a building and yet will also depend heavily on the building's intelligence.

## 2.2 Buildings versus Community

Emphasis in this report is focussed on the intelligence of a building. Ultimately an intelligent building does not need to limit its intelligence or local capacity to a single building. A greater benefit in all aspects will clearly accrue, if a single building can enjoy the benefits of joining one building into multiple buildings thereby forming a community, a campus, or possibly even a city. As it is evident to many tenants of rental properties there is a trend to such centralized operating facilities which has been adopted by many building operators and owners. For example, universities are a typical campus facility, which in many cases is monitored and controlled by a central facility. Frequently however, the interest of the central control facility is limited to a specific aspect of the campus e.g., security or computer networking for student or library use.

The benefit of an intelligent building networked into an entire campus has been demonstrated in a number of situations including some components of the Canadian government managed through the Public Works and Government Services (PWGSC) or large shopping centre operators, both of which manage very substantial real estate portfolios and are anxious to keep their operations as efficient and economical as possible. Thus, it is not unusual in such situations for the call for service related to lighting or HVAC to end up in a central facility where the call centre is staffed by technical experts who are not only able to understand the problem remotely but may also be able to address and correct the problem. There are many examples in the communications industry where the trend to centralize, often off-shore, call centres has been legion.

Several call centres operate in India, El Salvador, Egypt, the Philippines, etc., where calls related to many aspects of our society are addressed. The technicians in these low labour cost facilities have full network access to the corporate entities, accounts, control facilities, and have the ability to run diagnostics and if required, dispatch the local technician to address a problem. These local technicians will then arrive with the diagnostics completed and with any required parts in hand to address the original complaint. The corporate entity considers that this is part of an intelligent environment in which they can deliver a solution more effectively, more economically, and if they are resourceful they can even track individual failure rates and operate in conjunction with the original equipment manufacturer to improve reliability and thereby to further lower their costs.

The argument from the perspective of the operators (or owners) is that reducing their overhead in this manner provides an incentive to providing cost effective, speedy and competitive solutions to the market place. The community i.e., campus or city, becomes a wired entity. The network which serves a large group of users can be designed to be extraordinarily reliable without needing any continuous staffing or maintenance to ensure that reliability.

The readers will doubtless have raised concerns regarding the risk of hackers, viruses, or other malicious approaches to the integrity of the environment. The building control network has to be protected and experience to date has generally shown that providing that the network is not exposed to a public internet and remains as a private infrastructure there is a strong ability to ensure a very high level of protection. Since the intelligent building is largely a real time operation monitoring a fixed number of fixed devices there is little opportunity for miscreants to have access or to inject undesirable code or devices into the network. However, if a high value operation of a client is involved in the building, such an attack does become an attractive proposition. Increasingly, the security integration and resilience parameters are showing greater through life efficiencies by not outsourcing but rather having localised community networks with intelligent local response. This ensures continued operation in the event of an ice storm or similar 'global' event in which large area access to the cloud and other public communication networks is lost. External monitoring is therefore sufficient and allows effective firewalls around the operational system.

## 2.3 Technologies

The discussion of individual and specific technologies related to the intelligent building has been smattered through the earlier discussion and provision of definitions for the intelligent building. These technologies are therefore seen to depend heavily on communications in order to perform the monitoring and provision of data to those responsible for controlling the buildings.

Communications technology of choice today, is generally based on an IP-based network running at any one of the standard protocols and speed. If video is not part of the intelligent building (which it often is) then the amount of data actually exchanged between devices is relatively small. For example reporting on the status of a lighting controller, the status of a fan motor, or the credentials presented by a user wishing to gain access to an elevator floor are all very limited. Video cameras, particularly those using 360° viewing fields, colour images, and real time imaging will generate vastly more data. Provision of fibre-based networks easily accommodate these kind of volumes and images and the data used for such images can be significantly reduced by using well established technologies of only recording when data changes i.e., the use of an analytic process to control data flow. Therefore it is not easy to generalize what solution is most appropriate for the communication infrastructure in any given application.

The redundancy or resilience of the communication infrastructure is however paramount, particularly if many disparate systems are going to share this infrastructure as is being advocated by this report. Use of a single infrastructure is desirable but clearly occupants will become very frustrated if the communication infrastructure suffers a malfunction and as a result such as lighting, telephone, signage, computer networks, access control in turn all become victims of that single failure.

Adoption of an appropriate communication protocol to operate with each of the sub-systems is a function which requires cooperation between all of the design engineers. While there are lighting control systems, access control systems, sound systems, signage systems, etc., all of which can communicate using an IP protocol, the base commands used by some of these systems may invoke other protocols or may restrict the selection of systems. For example industry standards have evolved for access control systems, which have used traditionally used RS 485 based communications. While this is a changing situation, it is appropriate to analyse and decide whether a purely IP solution meets all of the needs for the project. Clearly, reliable power, i.e., use of uninterruptable power supplies (UPS) or generators is as crucial as needing the provision of network infrastructure which has resilient paths, ports, and devices. Self-healing networks are common



today but detailed analysis is required to ensure that there is no single point of failure so as to ensure continuity of service as a result of any anticipated problem. Recent publicity of the Heartbleed<sup>2</sup> vulnerability as well as the legions of patches, issued for all of their operating systems by Microsoft and other suppliers have provided ample evidence of the challenges of providing totally reliable solutions.

Therefore there are two schools of thought with regard to the provision of a reliable and secure solution for controlling an intelligent building. These two approaches are:

- Provision of a single system with all of the capabilities as is to some extent advocated by a number of the traditional HVAC systems often referred to as building automation systems (BAS) which have gradually expanded their capabilities to include a number of non-traditional BAS functions such as security, lighting control;
- The other alternative is to use an integration solution capable of talking a common language with a specialized individual system providing access control, fire system, lighting system, etc.

This latter approach has the advantage that each of the systems can ultimately be operated as an individual, non-integrated solution and provide assurance to the owner/operator that if there is a problem, the isolation will rapidly establish which component is causing the problem and which component can therefore be temporarily "shed" from the integrated solution.

Unifying software (such as in the former solution) has in some cases been developed by one or two specialised companies, which provide such integration to a very wide range of individual systems provided by other manufacturers. The result of this solution is a single screen on which all individual systems can be viewed.

Another subset of this solution is to use a number of independent systems all of which operate using a single communication protocol and which therefore can all sit on the same network and be addressed from any authorized computer on that network. The absence of a single screen integrating all of the status information is generally not a major disadvantage although the size of the network, the number of points being monitored, and the nature of the messages from each individual system can clearly lead to significant impacts.

The above comments demonstrate that the design decisions for an intelligent building are not predicated on a preconceived solution as they must depend on the particular implementation. It should also be noted that the design of a new building is a very different undertaking than the retrofit of an existing building. All these factors need to be analysed in order to assess and evaluate the optimal technology and solution for any situation. Selection of the designers who are going to perform this analysis are equally important and the owners, developers, and operators need all to be involved to ensure a successful project.

## **3** *Types of buildings*

---

### **3.1** *Single family*

It is unlikely that a single family dwelling would really benefit significantly from significant application of the intelligent building technologies concepts. There is little room for interaction between systems, in particular, as a single family dwelling does not generally have many of the

---

<sup>2</sup> Please see: <https://www.openssl.org/>.

systems which are found in larger or more complex buildings. Thus a single family home is not likely to have a fire alarm system although many homes today have a security system of some kind. Obviously the security system can in itself monitor for fire, smoke, or even temperature rise. Access control in a single family unit is limited probably to the front door and since all those normally living in such a unit are related to each other it is assumed that they would all also trust each other. Lighting may be automated and most residential HVAC systems use only one thermostat and do not have any form of direct digital control (DDC) or equivalent although some larger single family dwellings may indeed have HVAC zones which are controlled in some appropriate manner. Economic benefits, efficiency benefits or interactions of other kinds are therefore likely to be minimal.

### 3.2 Residential multi-unit

Typically a residential multi-unit is either a rental building or a condominium building in which centralized management of electrical usage, HVAC operation, security systems, guests, parking, fire alarm systems and common area lighting are all candidates for being managed in an effective and direct manner. By providing the central control with all of the foregoing and possibly also surveillance cameras the control desk can manage the building with just one single individual who can monitor, control or adjust as may be required. Without the integration of all the systems this individual would need several support individuals to review and adjust each of the individual systems. The intelligent building will allow monitoring and management of ongoing costs including maintenance activities in a manner, which will provide significant improvement in the services to the residence. In addition, depending on the configuration of the multiple-units (Multiple Rental Unit – MRU) or the individual units there is an opportunity for tenants to adjust their suites to meet their needs on a scheduled basis allowing special provisions, for example, for any residents who may be away on vacation, at daily scheduled work or otherwise to provide significant economies by optimizing the use of the HVAC and lighting systems.

### 3.3 Commercial buildings

Typical commercial buildings employ a combination of systems including all the systems found in a residential multi-unit environment together with a significant number of the functionalities appropriate to an office or even a retail environment. Some commercial buildings would also provide locations for retail, restaurants and for entertainment such as cinemas or conference facilities. Without going into infinite detail all of these functions rely heavily on various forms of automation ranging from parking and subsidized parking, through inventory management, music systems, paging systems, escalators and elevators and food storage systems. The integrated building technology (IBT) systems can provide for monitoring and measuring any or all of these operations so as to alert individual tenants if their food storage systems fall outside acceptable temperatures or if sales inventories have been exceeded. According to the policies, which may be appropriate to any given sales facility, there may be pressures exerted on retail merchants to pay a portion of their profits or sales volume as "rent" to the landlord. The intelligent building can provide a means of measuring the income or sales volume in an objective manner which would allow the landlord to measure his percentage. Evidently lighting, emergency signage and regular signage are all additional functions which can be readily introduced.

### 3.4 Hotel

A hotel is normally very open to benefit from IBT technology as, depending on the season, the city and general circumstances, including the day of the week, hotel rooms may be at a premium or

guests may be at a premium. From the hotel perspective its ability to adapt to the current occupancy rate is much aided by the use of IBT. The ability to "shut down a room" or to "open up a room" in response to an arriving guest or a departing guest can provide a significant impact on the bottom line. With accurate and complete information planning is easily achieved to only clean rooms which have been used, to only heat and to only light rooms which are occupied. Individual staff members can be readily monitored as part of the overall building effectiveness. Many hotels already provide suitable "intelligent" links between the television and the hotel's billing system. It is now regular practice for there to be a keyboard in each room and for one of the channels to provide a screen and communication so that guests can check out, settle accounts and order special services as they may wish. In summary, the hotel is fertile ground for increasing the benefits of automation through an integration of its operational systems, thereby yielding an intelligent building.

### 3.5 Hospital

A hospital is very sophisticated in some of the "intelligent" applications which are already widely used. Those functions are however largely related to the delivery of medical services. For example, many hospitals have developed or acquired special software used to track patients who arrive in the emergency room and require significant testing and processing within the emergency room, often before they are then discharged without having entered the hospital's system.

Patients are booked in clinics, laboratory requisitions are filed, hospital cards are provided, and psychiatric wards are managed. The intelligent building aspect however is left far behind because there is very little scheduling that can be accomplished in a manner which will yield significant benefits to the hospital's bottom line. HVAC is required 24 hours per day and lighting can only be "reduced" during "sleeping hours". The requirements of maintaining a hospital as "a publicly accessible facility" and to "provide effective security" is without question a contradiction. In many hospitals entrances are now being locked except for the emergency room which are still open 24 hours daily even when some of the other locations conform to a consistent need at all times. The requirements to ensure that standby generators are always ready to provide their services, that patient records are always available to the physicians providing treatment are two very different needs and there is little room to provide integration of these two requirements. The legal requirements to ensure confidentiality of all patient information is a good reason to consider segregating the networks used for building control and for providing medical services.

### 3.6 Factory

Factories are usually custom built in order to manufacture a car, a computer or another manufactured product. As such the processes necessary for the manufacturing are quite secondary to the control and management of the building. For this reason the intelligent building aspect addresses only the maintenance of the building(s) to ensure that the environment provided by the building is appropriate for the machines and processes carrying on the manufacturing of defined products. In other respects maintaining, managing and informing on the operation of the building itself is no different than the functionalities called for in a multi-unit residential or commercial environment.

### 3.7 Intelligent buildings and new business opportunities

The "intelligent building" concept goes far beyond supporting sustainability goals, saving energy, enhancing efficiency and reducing costs. The concept also represents processes as well as services, profits, job creation and capacities enhancement in the ICT and building industries. The concept

continues to be widely adopted in the market due to the fast expansion of mobile, cloud, grid and big data applications and networks connectivity benefits.

## 4 Other aspects

---

### 4.1 Operating costs and occupant comfort

A major objective of an intelligent building is to provide a building which can be operated at a lower cost, (i.e., to cut the unnecessary expenditure of energy when it is of no benefit e.g., do not heat or light areas when they are not occupied) and ensure that the systems are there to evaluate costs and to quickly respond to occupants' needs and maintain occupant comfort.

### 4.2 Tenants' satisfaction

The investment and efforts to make a building intelligent are ultimately all part of a marketing campaign by landlords and developers to ensure that the building becomes a "desirable" facility. This is only one small part of the overall thrust of developing a new building where the architect will endeavour to make it as appealing as possible, the engineers will endeavour to make it as comfortable as possible and the interior designers will take great care in ensuring that the "form" of the interior design makes people want to work in that environment. The function provided by the engineers and implementers will augment that capability, thus for example, attractive features can be added as in putting lights on the building which would change with the season, or with the time of day, or, with the weather, or with the extent to which the building is occupied meaning that the building when fully occupied may be coloured red or when the building is empty may be coloured blue.

With the widespread development of smart telephones with enormous capabilities the opportunities further exist that tenants or guests may be able to download suitable information for their own smart phones to ensure that their particular interests e.g., calling of an elevator or modifying their work space environment can easily be achieved by requesting different lighting levels, background music, or room temperatures. Fire alarm or other emergency information can be clearly defined in messages sent to the smart phones of all tenants. Instantaneous electrical utilization or billing can be monitored. With time of day pricing instantaneous monitoring of electricity meters or sub metering becomes crucial to maintaining close control on overall costs.

### 4.3 Maintenance

One of the key issues related to any intelligent building is that on-going maintenance of the facility is absolutely critical to maintaining the benefits of building intelligence. While most intelligent buildings will operate using less energy and water, equipment throughout the building needs constant maintenance to ensure that optimal performance is maintained.

The key is also to ensure that sensors are cleaned and calibrated on a regular schedule. Poorly performing sensors can be one of the main reasons that an investment in building intelligence does not result in reductions in energy and water usage.

The tables below<sup>3</sup> are examples of preventive maintenance schedule best practices. Such as a schedule can be automated within the framework of an intelligent building thereby ensuring more efficient and cost effective facilities management.

**Table 1 – Examples of preventive maintenance schedule best practices**

<p>Check on the boiler systems and measurements of the boiler efficiency. To monitor for proper combustion efficiency, carry out efficiency tests at least annually and calibrate burners so that delivered efficiency meets manufacturer specifications.</p>
<p>Check on the correct operation of ventilation and cooling controls. This involves checking that all set points are adjusted to meet efficiency requirements as well as seasonal and operational needs of the occupants for each day (including holidays), and time-of-day.</p>
<p>Checking of temperature and humidity controls to ensure they are set correctly and are responding as intended. There should be a bi-annual evaluation of the control systems.</p>
<p>Checking of air supply grilles to ensure they are not blocked and are delivering air as required.</p>
<p>Check for refrigerant leaks. For systems using refrigerant, maintain the refrigerant charge per the manufacturer's requirements. Keep refrigerant leakage under 5%.</p>
<p>Checking of cooling towers. This should include reviewing water treatment, bleed control and cycles of concentration, water temperatures, pump operation and sequencing, and sump during operation.</p>
<p>Scheduled filter replacement. Replace or clean filters in accordance with manufacturer's recommended schedule or design pressure drop. Ensure correct size and type of filter.</p>

**Table 2 – Examples of preventive maintenance schedule best practices**

<b>Every Five Years:</b>
Total quantity of outdoor air measured at minimum damper position, compared to total occupant requirements, based on published standards such as ASHRAE.
<b>Annually:</b>
Outdoor air intakes – obstructions, bird droppings, standing water, proximity to cooling towers, trash compactors, exhausts and other pollutant sources.
Minimum outdoor air damper setting.
Coil drain pans – cleanliness, presence of microbial growth, proper draining.
Minimum VAV box settings.
Duct and terminal coil cleanliness.
Duct insulation liner – cleanliness, adhesion, coating.
Ceiling plenum cleanliness (if used as a return air plenum).
Controls – ensuring continuous fan operation during occupancy, and correct positioning of dampers and VAV box valves.
Fire dampers – open.
Boiler combustion air – clear; sized per code requirement.
Cooling towers – water treatment functioning as intended.

<sup>3</sup> BOMA BEST Canadian Building Environmental Standards requirements.

**Table 3 – Examples of preventive maintenance schedule best practices**

<b>Semi-annually:</b>
Floor and equipment drain traps – properly sealed.
Air quality measurements in select occupied areas of the building.
<b>Quarterly:</b>
Operation of outdoor damper actuators.
<b>Monthly:</b>
Air filter loading.
Standing water in air handling units (esp. cooling coils).
Air handling unit interior cleanliness.
It is suggested that HVAC systems be re-commissioned every five years.

### 4.4 Evaluation – How Intelligent is an "Intelligent" building?

With a strong push towards intelligent buildings, there is an increased need to develop an independent and unbiased mechanism to evaluate how "intelligent" a given building is within a set of given attributes such as the individual systems and how well they are integrated.

There are a number of standard tools being used by different organizations to measure the effectiveness of intelligent building technology

As an example, BIQ is part of an evolving set of self-administered on line questions through which a particular project can be given a standardized score. This score is intended to reflect the intelligence of the building, which has little bearing on its energy efficiency. The original BIQ evaluation addressed the intelligence as a result of the integration of the communication requirements, signals and protocols. The evolving process is placing a much heavier emphasis on energy management including the ability to select the lowest cost of energy, i.e., the ability to change energy sources as a function of spot pricing and to evaluate the benefits accruing to the overall project.

Reports are generated which benchmark the different sub-systems with recommendations for improvement in multiple categories including communication systems; building automation; annunciation, security and control systems; facility management applications; and building structure and systems.

### 4.5 New business opportunities for the building sector and ICT industry

The expanded capabilities of smart services and the data they generate are ushering in a new era of innovation and competitive advantages for building owners. Buildings that are operated efficiently, at lower costs and reduced energy expenditures also enhance building tenant's satisfaction and create new business opportunities for all.

City authorities should focus on innovation, policy, economy, and infrastructure matters to build a strong framework to strengthen intelligent building initiatives so that they can gradually upgrade pilot areas which will become models to be imitated on a wider scale. This will help them to implement smart sustainable cities and buildings, in the next few years.



The convergence of building and ICT industry enables all players to:

- Create new business opportunities in the intelligent buildings and ICT industry;
- Satisfy the technical demands of the intelligent building market surrounding big data and data analytics applications;
- Bring more investments from vendors of both industries as a result of strategic partnerships between data analytics and building technology providers, which may include tenants and building owners.

## 5 *Climate change adaptation*

---

Climate Change related severe weather events are increasing in frequency and severity. These severe weather events include (but are not limited to):

- Urban floods;
- Extended heat waves;
- Ice storms;
- Extended cold spells;
- High winds / tornadoes / hurricanes.

These weather events have both a long term and short impact on the commercial building infrastructure in cities.

During short-term events, building infrastructure is impacted by major structural damage, damage to a building's support and utility systems, closure and loss of revenue among other items. Over the long term, severe weather and more extreme temperatures lead to accelerated degradation of a building's envelope, utility systems and infrastructure. Steps need to be taken to maintain the building exterior and envelope to prevent damage to the building and its' equipment. At the same time, the design and intelligent infrastructure of the intelligent building can assist with minimizing the effects of extreme events.

In order to prevent damage from flooding events, major HVAC, electrical and communication equipment should not be located below or on grade locations or if it is not possible to move equipment above grade then equipment rooms should be sealed against water intrusion.

Elevator hoist ways should similarly be sealed and procedures developed to ensure that elevators are automatically sent to higher floors in the event of a flooding event.

Demand response capability means that the intelligent building is able to reduce the building's electrical load for HVAC and/or lighting during periods of high system wide demand, typically at the request of, and perhaps with incentives from the utility. This is particularly needed during extended heat waves to ensure that power grids are not overly stressed.

Proper design of external landscaping and storm water management facilities can reduce the potential effects of severe rainstorms and urban flooding.

Intelligent buildings normally also have back up power systems that can automatically provide power for short or extended periods of time to allow for evacuation or maintain building operations.

## 6 Examples of Intelligent buildings

### 6.1 Molson Center

The Molson Centre, is a 20,000+ seat capacity arena located in Montreal, Canada. In this facility the inactive building can be safely managed and monitored by two individuals.

Monitoring the screen with the ability to occasionally dispatch the second individual to validate, verify or to address a situation should it arise. The integration of the systems includes access control, intrusion, surveillance, hold up alarms, elevators, fire alarm system, paging system, television displays throughout the building, emergency evacuation systems/address systems, ice surface management, voice, data and restaurant systems, beer dispensing systems, food storage and kitchen systems, parking systems, water leakage systems, electronic photoflash systems and systems for the hard of hearing or simultaneous translation.

While the list is extensive there are some key novel features which were introduced into this building. The Authorities Having Jurisdiction (AHJ) permitted the use of the public address system for emergency evacuation purposes providing certain safeguards were fully demonstrated (which were successfully accomplished). The building may be locked when occupied under special provisions permitted by the AHJ.

All communications are handled through a single common utility (common backbone) thereby eliminating individual and independent communications systems used for each application.



**Figure 2 – Molson Center Montreal, Quebec, Canada**

Photo credit: courtesy of IBI Group

A single access card is used for all access purposes, although in some specific high security applications a door will only open when two cards are independently swiped within a short delay.

Special features were incorporated on the telephone and audio systems for broadcasting and reporter purposes.

Access control cards used by guards automatically from a "guard tour" reporting on the progress of a guard moving along a randomized but defined sequence of doors. Aberrations and unexpected delays automatically initiate alarms. These same cards can function as a signal to activate or extinguish selected lights.

Lighting control is fully automated through graphic screens allowing for all kinds of different configurations in accordance with different uses to which the facility is exposed. Cameras are directly associated with alarm conditions so that in the event of any kind of alarm suitable camera images are displayed and recorded. In particular the crucial alarm images are always displayed on a dedicated alarm screen.

The building access control system has been integrated with the Municipal subway because the Metro has an emergency exit in the building to which the Metro staff require independent access.

The fire alarm system is fully integrated with the security system so that any fire alarm is evaluated, reported and displayed in detail on the security console. As this console is part of a network, it is also available to any other authorized individuals such as the building manager. When a fire alarm incident occurs this information is made available to the access control system through a listed interface which then leads to the printing on a dedicated printer of the suitable "response plan". This response plan contains whatever information is designated for that location and may, for example, include contact information for the occupant of that location.

## 6.2 Terminal Windsor

The Terminal Windsor is a railway station for commuter trains serving the west island of Montreal, Canada. The key elements of this intelligent implementation relate to the automated coordination of all the station functions with the train schedule.

Thus, for example, platform doors are normally closed and as passengers approach, the doors will open if those doors are scheduled to allow boarding of the train. Shortly prior to the schedule departure time the doors will no longer open in response to passenger approaches.

All of the door functions are indicated through schedule update information displayed on monitors around the station. Scheduling of the doors has also been organized to allow passengers to go from the station to the platform for departing trains or from the platform to the station for arriving trains with special overrides for stations staff who may be permitted to go onto the platform or into the station even when trains are not necessarily at the platform.

Automatically paged messages announcing arrivals and departures are again integrated into the scheduled operations. The back office maintains the schedule on an active basis so that when the trains do not adhere to the schedule, minor modifications to the schedule are easily introduced and will govern the operation of the platforms.

## 6.3 Flint Mass Transportation Authority Downtown Terminus

The downtown terminal for the Flint Mass Transportation Authority (Flint MTA) was totally renovated and during this renovation numerous forms of integration and intelligence were incorporated into this building. The location where the downtown terminus is located is a fairly high crime area so there are significant concerns related to the security of staff, passengers and vehicles in the parking lot. Considerable efforts were therefore made to restrict and control any criminal activities.

A complex interlock system with respect to arriving busses and departing busses allows passengers to transfer from one bus route to another. This system ensures that the automatic doors from the bus platforms into the bus terminus and from the bus terminus onto the bus platform are only active during the times when the buses are present and are not yet scheduled to depart. Furthermore only one bus can depart at a time using a mechanism of automatic lights so that the possibility of collision or colliding with a passenger is minimized.

Surveillance cameras, up to date bus scheduling information, television displays and a small conference facility are all incorporated into this design.

There is full integration with a fire alarm system and a stand by generator so as to ensure that the electromagnets used to control the doors operate in full compliance with the local ordinances.

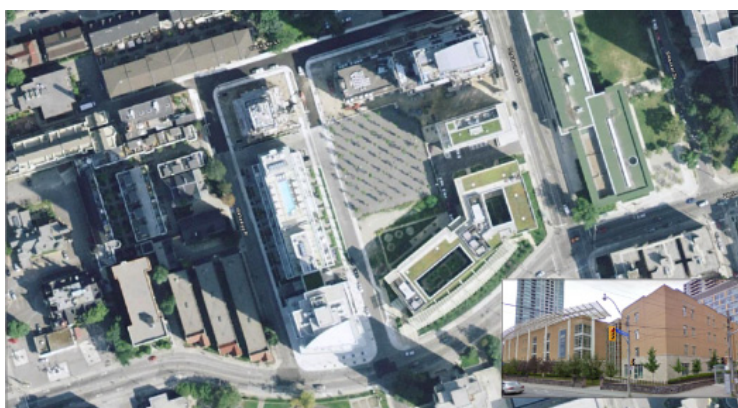
All communications wiring is carried over a single networking infrastructure. The communications facility at the Flint downtown terminus is part of the overall Flint MTA communications network and is linked via a wireless link from this facility to the MTA head office.



**Figure 3 – Mass Transit Authority Downtown Terminal facility Flint, Michigan, US**  
Photo credit: courtesy of IBI Group

## 6.4 Wellesley Long Term Care

All communications is carried over a single communications infrastructure including nurse call, telephones, data, access control, and integration with a fire alarm system, number of elevators, parking.



**Figure 4 – Wellesley Central Health Corporation Toronto, Ontario Canada**  
Photo credit: courtesy of IBI Group



## 6.5 World Trade Centers

The World Trade Centers (WTCs) serve as international ecosystems of a global network and integrated trade services under the umbrella of a prestigious brand. WTCs stimulate trade and investment opportunities for commercial property developers, economic development agencies, and international businesses looking to connect globally and prosper locally.

WTCs provide the following services and more:

- Market research and trade information services;
- Business center, trade show and exhibit facilities;
- Meeting venues and translation services;
- Video conferencing capabilities;
- Temporary and permanent offices;
- Access to key governmental agencies in over 100 countries;
- Trade development and services (trade missions).

## 6.6 Microsoft Headquarters Pilot Building

The Microsoft corporate headquarters in Redmond was used as a living lab to pilot several intelligent building solutions. This was part of the firm's efforts on environmental sustainability, aimed at cutting their emission footprint and reducing the overall operating costs. Most importantly, the firm believes that technology can help improve efficiency in all areas of energy and resource use (Energy-Smart-Buildings, 2011).

The focus started initially with 13 buildings of about 2.6 million square feet, with the age of the buildings varying from over twenty years to buildings that were almost new. The Redmond Operations Center (ROC) was located in a drab, nondescript office part, with a new state-of-the-art 'brain' within it.



**Figure 5 – Microsoft Headquarters Pilot Building**

Equipment level data collected from either the control panel or BMS servers are sent to the middleware server, and for some, it is done over an open protocol (BACnet). There were energy meters present to provide the sub-metered electricity consumption data for the utilities. The internal enterprise data warehouse also consists of contextual information like their building type and headcount. The middleware server acts as an aggregator for all on-site data and will transmit it

securely to the intelligent building solution vendor, who will run the analytics and share the output with Microsoft staff via an interactive graphical interface on the web.

Plug loads were a focus for this facility. The high plug load accounted for the same amount of energy as the building base load. Intelligent building solutions allowed for the tracking of plug loads based on the area, which serves as a live indicator to all the building occupants as to how much electricity they are consuming. It was usually consumed by building occupants' devices such as their laptops, cell phones etc. Thus, Microsoft could leverage on the information provided to motivate users to reduce their plug load.

Besides plug loads, Microsoft also utilized an intelligent building solution that serves as an analytical layer above the BMS that creates a consolidated view of granular energy and operational data across Microsoft's building portfolio. The main idea is that buildings will be managed holistically through a unified interface, instead of many disjointed systems, where the existing management systems are all connected to an analytical layer. Their key objectives were to save energy and focus resources, and focused on Fault detection and diagnosis as well as Alarm Management.

In addition, there was a goal to identify any building faults and inefficiencies in real-time by analyzing the data streams extracted from the building systems. Through this new approach, it enables the engineers or facilities manager to identify according to the prioritized faults, where this intelligent building solution automatically provides the prioritized equipment faults and the estimated cost of wasted energy. This facilitates quick and efficient decisions as to which faults require immediate attention and whether the savings justify the expense for repair.

When a particular system is faulty or inefficient, it might require a lot more energy to tackle the same load and it might consume energy without delivering its task. Their software is also able to provide useful information, quantifying wasted energy from each identified fault in terms of dollars per year. Software analytics is also beneficial because it increases the visibility of systems, allowing Microsoft to identify a faulty control code issue that a conventional BMS would miss.

In terms of Alarm Management, the issue is the daily flooding inbox of engineers with a ton of automated notifications, from the most insignificant notifications the start of a self-test, all the way to the most major issues like a power outage, where the most critical problem can be missed due to the overwhelming number of notifications and alarms, causing a greater delay to an already urgent problem. This reduces the engineer's effectiveness significantly. However, with the intelligent building solution, both patterns and correlations can be identified effectively.

Microsoft also has an advanced irrigation system in their Redmond campus that ensures about 11 million gallons of water saved annually. Recycling is very prominent in this campus, where an average of 141 tons of material is recycled every month. This includes glass, aluminium, plastic, paper, organic waste, wood pallets and copper wires. This campus also started to compost their food waste from cafes, kitchens and conference rooms in an effort for waste reduction (Microsoft Sustainability Fact Sheet, 2008). Therefore, from this building, one can learn how technology can be incorporated into buildings, to increase the efficiencies and save a huge amount of money as a result. This headquarters campus is generally focused on energy management, reducing operating costs and reducing carbon footprint.



## 6.7 Infosys Building, Pocharam campus in Hyderabad

This Software development block (SDB) of the Pocharam Campus in Hyderabad by Infosys, as shown on the left, has a total built-up area of 24 000sqm. The building is distributed into the east and west wing, where 85% of the total building area is air-conditioned office space and the total building occupancy is 2500. The most unique feature is that the building is split into 2 identical symmetric halves (exterior and interior), where one half is cooled by conventional but efficient air-conditioning, and the other half by radiant cooling.



**Figure 6 – Infosys Building**

Photo credit: Sekhar Kondepudi

This building was designed with a highly efficient day lighting systems (Volumetric lighting), which allows for over 90% of the office space to obtain natural sunlight, reducing the need for artificial lighting during the day time (Kurmananth, 2012). This was achieved through the use of light shelves, narrow floor plates, and a reduced window-to-wall ratio. Passive solar design was also implemented by aligning the buildings along an east-west axis for minimum heat exposure, and terracing their buildings to minimize the impact from the summer sun (JLL, 2015). The Pocharam campus installed a 400kW solar plant that generates about 700,000 kWh per annum, resulting in the reduction in reliance on the power grid.

An efficient cooling technology was also derived – Radiant cooling. This technology has the potential of changing and drastically optimizing the cooling processes used for air conditioning in buildings. Within the first couple of months, the side using the radiant cooling had energy savings of about 40% compared to the other side, which was measured through extensive metering. Radiant cooling is achieved by cooling the slab which then absorbs the heat (radiation) generated by people, devices, lighting and equipment that are exposed to the slab.

The building also featured a state of the art, BAS to monitor and control the operation of the various building systems accurately with over 3000 sensors placed throughout the building to monitor the building condition ranging from the chiller plant to indoor air conditions.

Infosys aims to enable processes for improving their systems for monitoring water recycling, with the aim for an achievement of long-term water sustainability. Fresh water was only to be used for human sustenance.

Rainwater harvesting was incorporated through surface-water catchment areas and storage in a man-made lake within their campus. Grey water is used for landscaping, flushing purposes and

cooling towers. Efficient plumbing fixtures and the use of recycled wastewater resulted in about 50% less water consumption versus similar buildings.

Other water consumption initiatives include the installation of pressure reducing valves in pipelines and the installation of sensor taps in high-density locations, calibrating for a decreased flow.

From the technological point, electronic water meters were installed at all outlets of underground reservoirs to improve the monitoring accuracy and to detect leaks (Infosys, 2012). The water meters can be used to further analyse which systems are not functioning efficiently.

Carbon dioxide (CO<sub>2</sub>) levels undergo continuous monitoring to ensure good IAQ for the occupants (Kurmananth, 2012). The radiant cooling system technology inherently provides a healthier IAQ because the air is not re-circulated in the system. An abundance of treated fresh air is provided to the occupants. This accurate control of temperature, relative humidity and CO<sub>2</sub> levels was possible due to the BAS (Sarstry, 2012). The Pocharam campus is seen to be strongly advocating green living, as well as incorporating new technologies into the buildings to achieve a well-rounded green and smart building. It does put in effort to improve even their water, waste and well-being management, rather than only focusing on energy management. Their aims lie in not only reducing operating costs, but also to reduce the carbon footprint.

## 6.8 San Francisco Public Utilities Commission (SFPUC) Building

This building is the San Francisco PUC headquarters, located in San Francisco, CA. This is a thirteen storey Class A office building of about 277,500 square feet in size. It was also called 'the greenest office building in North America', when it opened in July 2012, being known for its sustainability and energy savings. This building is a LEED Platinum building, where it houses approximately 950 employees.

SFPUC engages a highly efficient exterior building enclosure with exterior sunshades for daylighting, glare management, and to minimize heat gain. Daylight is also harvested for the use of the building, as facilitated by the light shelves integrated into the window walls for increased efficiency. The installation of workstation task lighting reduced the power needed for additional lighting.



**Figure 7 – SFPUC Building**

Energy is also generated through the wind turbines that are installed along the façade of the SFPUC building, and three roof top solar platforms that collect solar energy. Both of these have metering

devices attached for data collection and analysis to allow for changes can be made in meeting the building's energy demand.

The building uses the IBMS to integrate data from various building systems to allow for the read or write capability of 13,500 data points. This integration allows for increased functionality and operability between different systems, (software applications and operational tools) for monitoring, and managing the building's performance in real time (Jim, 2012). This is a demonstration of how the implementation of technology can reduce the impact of a building. The IBMS monitors and manages the data with analysis and control, and regarding energy management, it monitors and manages these various systems: elevators, lighting, HVAC, power monitoring, solar energy collector metering, wind energy power generator metering, interior and exterior shade control.

Rainwater harvesting system is in place in the SFPUC in a form of a 25,000-gallon cistern used to capture rainwater from the roof and children day care center's play area. This water is treated and distributed to irrigation areas around the building. The use of water-efficient landscaping allows the captured rainwater to meet all of the irrigation needs.

SFPUC also incorporated an integrated Living Machine System that treats 100% of the building's grey and black water for reuse to flush the toilets in the building. The system treats about 5000 gallons of wastewater per day, and allows for the reduction in consumption from 12 gallons per person, down to 5 gallons (SustainableWater, 2013). This system uses a series of diverse ecologically engineered wetlands, located in the sidewalks surrounding the headquarters and in the lobby of the building, to treat the wastewater.

The IBMS also monitors and manages data from the wastewater treatment system and the water reclamation in this building, so that this data can be further analyzed and the system optimized.

Natural ventilation is obtained with the use of operable windows and raised floors also facilitate the idea of natural ventilation, enhancing the overall IAQ (KMDarchitects, 2012).

The usage of IBMS in this building has had huge positive impacts on the building. The IBMS also control additional areas such as demand response, building performance analytics, alarm management and public information and education. The data in the IBMS is transformed onto dashboards. Visualization of the data is paramount and there are over 450 dashboards being developed to provide the facilities team, building operators and even the public, with information that are specifically catered to their needs. Users of this information can then be prepared to make sound changes to the building's optimization, performance and efficiency (Sinopoli, 2012).

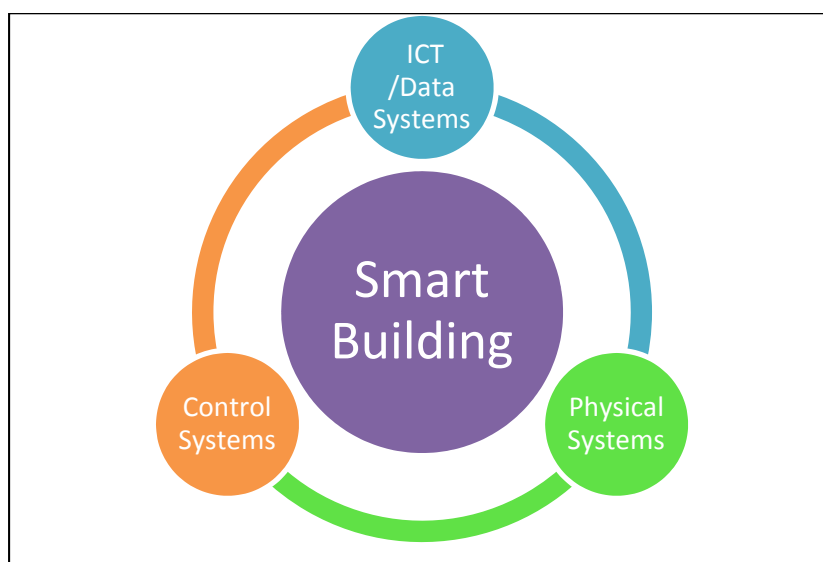
## **7** *Typical systems in an Intelligent Building*

---

A typical intelligent building can be broadly classified into 3 systems:

- (1) Physical
- (2) ICT/Data
- (3) Building Control

The integration of these broad categories is what constitutes an intelligent building as illustrated below.



**Figure 8 – Typical systems in an intelligent building**

Photo credit: courtesy of IBI Group

## 7.1 Physical Infrastructure

Physical Infrastructure is a "given" in an intelligent building, in terms of systems that will be there independent if the building is a smart or not. Therefore, these aspects are not discussed in detail in this report. However, it is important to recognize that these very systems which need to be made more intelligent and communicate with one another in an intelligent building. These aspects are covered in what is being termed as "Building Control Systems".

- Air Conditioning
- Lighting
- Elevators
- Water and Plumbing
- Electrical
- Fire Alarm
- Façade & Interior Décor

## 7.2 Data and ICT Infrastructure

An intelligent building is predicated on the use of data and communications and typically includes all the aspects related to data and communication both physical (hardware) and software.

1. Networking Infrastructure
2. Include Cabling, IP Networks, Voice, Video, Data & Wireless
3. Data Security

It is essential to make the different systems talk to each other and for software based smart decisions, the ICT /Data Infrastructure is critical. This ICT infrastructure is not only for ICT related systems such as Voice, Video, Data, Wireless, Data Security etc., and associated enterprise software applications, but forms the basis on which the different control systems can communicate with one another.

### 7.2.1 Overview

One of the key aspects of an intelligent building is the ability it has for the different sub-systems to communicate with one another. This communication will occur over the ICT infrastructure. The ICT infrastructure is the transport medium (wired and wireless) that carries all the data: voice, video (multimedia), security, VoIP (voice over IP), PoE (Power over Ethernet) throughout the building or campus. It forms the backbone why which data travels from one location in the building to another, how the different sensors and actuators communicate as well as how different systems (HVAC and Lighting for example) communicate with one another. It can include everything from the data-center to the desktop, wired jacks at the wallplate, wireless access points, structured cabling and associated equipment.

Hence, many intelligent buildings try to optimize the use of ICT infrastructure across the different systems in a building for example access control, video surveillance, building automation and other functions in the building. Such an ICT infrastructure balances the wired infrastructure with the use of wireless systems such as Wi-Fi and other wireless technologies throughout a building. As ICT continues to converge with traditional building control systems this infrastructure becomes increasing a critical and key attribute of an intelligent building.

It is important that an intelligent building not only have a secure, converged data network but also the following attributes:

- Integrated Voice, Video and Data;
- Data Security Measures – including encryption, admission and intrusion detection;
- Data Quality of Service (QoS);
- Bandwidth Management;
- Redundancy (to account for failure) including Uninterrupted Power Supply;
- ICT device management.

Typical technologies that are part of a Data / ICT infrastructure include:

- Networking LAN infrastructure;
- Core Routing Switching;
- Access Switching;
- Wireless Networking;
- Firewalls and Network Routers.

In addition to the above technologies, the same infrastructure will have the capability to provide support and connectivity to other building related technologies and services like:

- Building Automation & HVAC Control / Energy Management Systems;
- Lighting Control Systems;
- Building Security and Access Control;
- Video Surveillance Systems;
- Fire and Safety Systems;
- Car Parking Systems.

### 7.2.2 Networking Infrastructure

The Local Area Network (LAN) is the mechanism by which access to network communication services and resources is enabled for end users and devices spread over a single floor or entire building. Since doing this in a "flat" manner is not efficient, a hierarchy or tiered model is often used. This allows the network to be broken up into groups or layers.

Such a modular approach allows each layer to implement specific functions, thereby simplifying the network design, deployment and management of the network. Modularity enables the creation of elements that can be replicated throughout the network and therefore a simple way to scale the network for the entire building.

Another advantage of such a modular and hierarchical approach is that if there are some fixes due to faults to be made to a given subset of the network, such changes are contained to that subset and the other parts of the network are not impacted. This improves network efficiency and resiliency.

A common approach to LAN design includes the following three layers:

- Access layer—Provides endpoints and users direct access to the network;
- Distribution layer—Aggregates access layers and provides connectivity to services;
- Core layer—Provides connectivity between distribution layers for large LAN environments.

Such a network would run throughout the building.

### 7.2.3 Access Switches

At the bottom Access Layer, the Access Switches aggregate all the end user's traffic from Desktops, Laptops, Smartphones, IP Phones, and Videoconferencing terminals. Typically Access Switches can be placed on a per floor basis. One expects 1600 users, an average of 65/floor, and the switching bandwidth and port stacking needs to be sized accordingly.

### 7.2.4 Wireless Access Points

As a result of increasing use of Laptops, Tablets, Smartphones, it is also imperative that Wi-Fi access be provided. The average area of a floor is around 4000 sq. ft. This area and wall partitioning and users/floor should be considered while sizing the Access Point count and placement on every floor. The Wi-Fi controllers can be placed in the Server Room.

### 7.2.5 Core Switches

The Core Switch performs the function of interlinking the access switches and providing user connectivity to servers and also to the Internet (shown as WAN in the picture). The core switch placement must be optimized such that LAN/Ethernet cable runs from all the floors to the core switch do not cross the specifications. Where there is issue, fiber connectivity must be considered.

### 7.2.6 Firewalls

They protect in following ways:

- Protect servers (e.g., email servers, web servers) from malicious external attacks such as email spamming, website defacing etc.
- Protect network from malicious external Denial of Service attacks through incorrect or malformed IP packets.
- Protect users from malicious external attacks through incorrect or malformed HTTP data.



### 7.2.7 Routers

Routers provided connectivity to the external world of Internet Service Providers. The picture shows this connection to an ISP.

Some basic routing may be needed within the building based on the requirement assessment to provide network isolation (also called subnets) between various departments occupying the building. This is also termed Layer 3 switching.

## 7.3 Building Control Systems

While there are a large number of different possibilities, the list below provides examples of common "smart" control features which integrate with the different physical systems to ensure that all the systems act together in an optimized and efficient fashion – thereby improving efficiency and reducing cost.

- Building Automation System (BAS) – HVAC & Energy Management
- Lighting Control System
- Fire & Life Safety Control Systems
- Access Control
- Video Surveillance Systems
- Parking Guidance and Management Systems
- Integrated Building Management System

### 7.3.1 Building Automation – Smart HVAC Systems

Typically, when one refers to a Building Automation System (BAS), it refers to the various components of the HVAC control system. HVAC equipment is one of the most complex aspects of a building since it has many components ranging from chillers, boilers, air handlers, fan coil units, associated electrical and mechanical systems just to mention a few.

While an HVAC system has one primary goal – to keep the occupants of the building comfortable it also is the single most consumer of energy in a building – over 60% of a building load. Hence, the balance of what can be done to ensure it meets the comfort and wellbeing of its occupants while minimizing energy use is the key to a good BAS. This means that many parameters need to be measured, analysed and then appropriate action or control need to be performed. For example indoor environmental parameters such as occupancy, temperature, humidity, noise, air quality, ventilation and outdoor environmental parameters such as outdoor temperature, solar radiation and other weather variable. All of these and more concurrently optimizing the operations of the HVAC system to minimize energy use.

The large number of variables and components in an HVAC system necessitates extensive automation and system integration. For example, in a smart building the HVAC system may have the ability to sequence chillers, pumps, boilers automatically based on the different conditions and constraints including but not limited to run time, time of day, occupancy and other similar parameters.

### 7.3.2 Smart Lighting Control

Lighting is a critical aspect to any building. It is both aesthetic as well as practical. Buildings need to provide sufficient lighting to enable their occupants to work perform their tasks effectively. Finally, lighting typically consumes approximately 20 % of a building's energy load.

An intelligent building typically has a lighting management system across all the usable footprint of the building. It will need to be energy efficient with LED fixtures, have dimming capability, be networked and controllable from almost any location. It also should have a local, zonal and global (building) wide schedule and override capabilities. Daylight harvesting, that is maximizing the use of sunlight to minimize artificial lighting is also important. This is typically achieved using manual or automated shading, photo sensors in lighting zones and rooftop solar intensity sensors.

Finally, an intelligent building could utilize information from the lighting system to help influence other systems – for example if a building floor is dark, it implies no one is in the office and therefore the HVAC system can also be turned off.

### 7.3.3 Fire Alarm & Safety Systems

Fire alarm systems have a primary job is to ensure the safety of occupants by providing them warning of smoke and fire. Manual detection is still prevalent, but increasingly building have automatic initiating devices such as heat (thermal) detectors, smoke detectors, flame detectors, even cameras. While detecting a fire is important, suppressing the fire is critical and therefore, most intelligent buildings will have an automatic fire suppression system with a centralized fire alarm panel.

Other attributes of a fire alarm system in an intelligent building may include:

- Addressable sensors.
- Intelligent sprinkler heads.
- Notification devices such as strobe lights and integration with public address (PA) systems.
- Smoke Management and Containment.
- 24-hour alarm monitoring and recording of response.
- Integration with other building sub-systems
  - HVAC allowing for restriction/containment of smoke through dampers/fans
  - Integration with access control allowing automatic unlocking/opening of doors.

It should be noted that due to the nature of the life safety aspects of such systems, redundancy and fail-proof backup is critical and in many cases required by law. These control systems are often not directly linked to other control systems to ensure that they are isolated from potential faults in other systems impacting the fire systems.

### 7.3.4 Access Control Systems

Physical security in a building is something that we now take for granted and it is accepted that most buildings will have restricted access. With security becoming a critical aspect of daily life, access control systems are a critical component in smart buildings. Such system also interfaces with life safety systems, fire alarm system and other smart building systems such as video surveillance and HVAC. It can also act as a proxy to verify the presence of a person inside the building for human resources/attendance purposes.

In an intelligent building, an access control system should be deployed with multiple levels of authentication as needed. The access control system is normally designed to maximize security and include specific access privilege allocation (role based access), access to elevators, parking garages and also be supported by other security systems such as an intrusion detection system. An access control system can also be used to provide data related to occupancy statistics, which then can be used for helping optimize the building automation systems for improved HVAC and Lighting control.

### 7.3.5 Video Surveillance and Analytics

Almost all buildings now have a video surveillance or closed-circuit television systems (CCTV). These are typically part of the building's security and life safety system. Along with the trends in the marketplace, the technology for video surveillance has migrated from analog to digital technology. Internet Protocol (IP) based systems are now common, so the data can be transported over the standard building ICT network. Digital camera image sensors are based on CMOS sensors which use "progressive scanning" technique. There is no need for alternate odd and even frames in this case. Still images are perfectly clear, and face recognition is now possible even when video is paused.

IP-Based video surveillance utilizes the existing ICT network infrastructure and therefore reduces costs. The ICT infrastructure allows for improved network security, remote access to the systems, integration of wired and wireless technologies for video transmission and remote notification of events and alarms. It also enables the integration of the video surveillance systems with other building technology systems such as access control, enabling more functionality.

Some of the benefits of Physical Security using surveillance camera include:

- Reduce the risk of thefts and burglary
- Protect communities or high-rise buildings from strangers
- Record violence, assault or theft as evidence in prosecution
- Reduce bullying and loitering
- Improve discipline and behavior
- Detect entry of unauthorized people into buildings or communities
- Detect bad behavior in public places such as government offices etc.
- Safety and Security of staff, employees and visitors
- Remote management observation

### 7.3.6 Smart Connected Workplace

The office space has many different systems – Audio-Visual, Voice, Video Conferencing, E-mail and a smart office building can leverage these systems to act together. There are a number of examples related to the use of ICT to make the operations of a building smart. Just as an example, 2 systems will be discussed in more detail:

- Digital Signage & Displays
- Conference / Meeting Room Scheduling

### 7.3.7 Digital Signage Systems

Digital signage allows different messages to be delivered to the target audience in a very visual manner, in real time. Digital signage is a compelling communications technology that is effective, immediate and dynamic. In the spirit of "real time" communication, messages are relayed instantaneously and these messages can change constantly depending upon the context and situation, messages can also be changed instantaneously. It can be utilized in a variety of building types. Digital signage typically enhances the user experience since it is used to inform, entertain, communicate and can also be a potential source of advertising revenue.

Like any computer-based system, digital signage comprises software applications running on hardware devices. Most digital signage software has 3 parts: (1) Content management, (2) Device management and (3) Data management. The hardware components of a digital signage system

include displays, servers and data storage. These are determined by the technical requirements and size of the network the digital signage is operating in.

Recently, one of the most innovative uses of digital signage has been for life safety, where it complements the fire alarm and life safety systems. In an emergency such as a fire, if the stairwell is not safe for evacuation, the digital display located at egress points (next to the “Exit” signs) can provide appropriate safety messages.

### 7.3.8 Room Scheduling Software

Most large buildings have numerous conference and meeting rooms. There is a case to be made for to control the scheduling of meeting and conference rooms in order to not only manage any meetings/events in those rooms but also be able to integrate energy and other savings measures. Using software applications which are integrated with the HVAC, lighting and occupancy sensing systems, one can effectively find and book space, and also reserve equipment, unlock doors, change the temperature set-point, or turn on the lights and eventually revert the room back to unoccupied mode. This helps optimize the energy use in the conference rooms so that the room is lit and cooled (or heated) just prior to the scheduled meeting and brought back to unoccupied status once the meeting is over.

### 7.3.9 Visitor Management System

Visitor management refers to tracking the use and movement of visitors to a building or site. Visitor registration & management is a now an integral part of an intelligent building. There is a case to be made to screen and track the many visitors who pass through the entrances to a facility. Such a system will contribute to the safety protection and wellbeing of the occupants and employees in the building.

A visitor management system will typically provide a record of building use and therefore is often used to complement building security and access control systems.

### 7.3.10 Parking Guidance and Management Systems

An intelligent building will need to have a sophisticated parking control mechanism not only from a convenience perspective for drivers but for a security and fee collection perspective. A good parking management system ties into the other building systems as well.

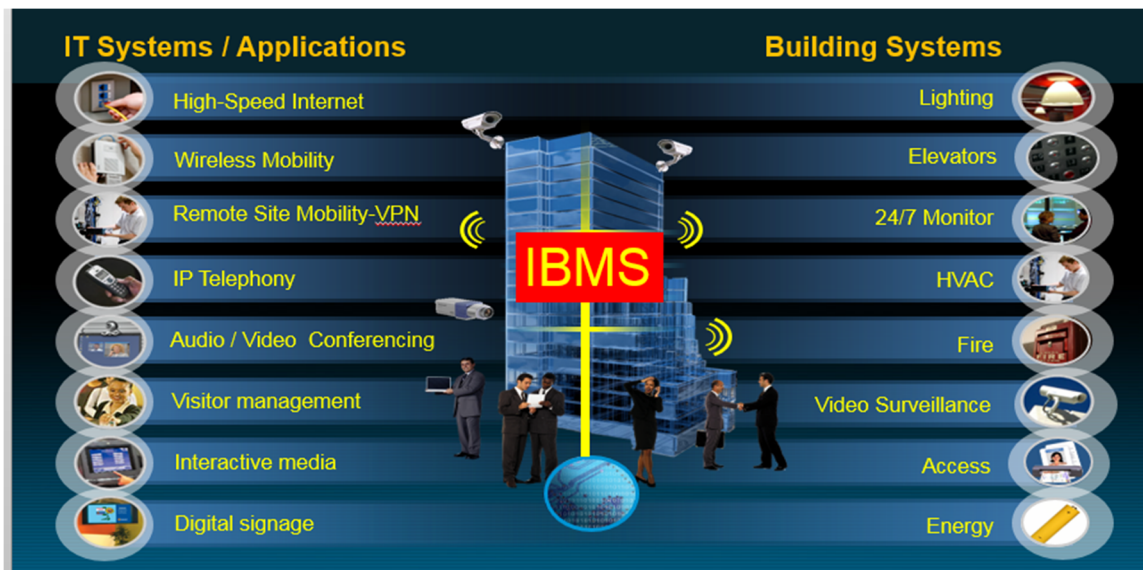
Parking Guidance & Management Systems provide a way to help drivers park their cars quickly, safely and easily and at the same time keep the parking lots, safe and secure. It typically ties into the access control and video surveillance systems.

Normally the following is included: (1) software to tie in all the components of the Parking management system, (2) automated access control system – Automatic gates, barrier controls, ticketing systems, (3) Security – video surveillance, under vehicle scan system, licence plate recognition systems, (4) Automated Fee systems, (5) Real-time Vehicle counting and (5) Real time parking guidance showing the empty slots at every level.

## 7.4 Integrated Building Management Systems

An Integrated Building Management Systems (IBMS) acts as the “heart” of the Intelligent Building. It is a holistic platform designed to manage all the disparate individual systems in a building including BAS (HVAC), Lighting, Security, Surveillance, Access, and Life Safety as an example. Each of these individual systems typically acts individually and does not communicate with the other systems. For example, the HVAC system is independent of the access control system and the lighting system. If

these were integrated, then it could be arranged that the HVAC and Lighting turn on only when the access control system shows someone to be inside a room, floor or building.



**Figure 9 – Example of an IBMS**

Photo credit: Cisco

If all of these are brought under a single umbrella, such a system is known as an Integrated Building Management System (IBMS). Such a centralized system will enable real time centralized monitoring and control of Infrastructure systems such as building systems (HVAC equipment, Thermostats, Lighting, Life Safety & Security Systems, Physical Security, Elevators, Meters – Energy, Water and Gas, Sewer etc.). It will be a comprehensive, standards based, communications network-based solution for intelligent building automation and enterprise management.

Using advanced software tools, the IBMS provides a smart building the long term capabilities needed to save costs, efficiently manage and optimize building operations and ensure long term sustainability.

#### 7.4.1 Combining Multiple Systems

Typically, an IBMS can monitor and manage every data point from every building system. The integration of all the data points of all the building subsystems relatively new and has great potential to monitor and manage a building's performance.

As an example, in the San Francisco Public Utility Commission building, the systems monitored and managed by the IBMS include:

- Elevators
- Waste Water Treatment System
- Mechanical Direct Digital Controls
- Digital Network Lighting Controls
- Power Monitoring and Control System
- Fire Alarm and Detection System
- Solar Energy Collector Metering
- Wind Energy Power Generator Metering

- Interior & Exterior Shade Control System
- Weather Station Monitoring System
- Window Washing System
- Water Reclamation

Most IBMS systems will incorporate all of the traditional building management functions such as document management, trending, system scheduling and data archiving. However, in addition there is an integration into the Facility Management (FM) systems such as work orders, asset management, inventory, and maintenance. Further integration with the Building Information Management (BIM) systems of the building will map the building, its systems and components in 3D. This will allow for a truly integrated and optimized building where in an alarm in the IBMS triggers the FM system and the BIM system provides a real time 3-D view of the situation, its location and possible fix. This creates a “meta” building database to help improve building operations and engineering.

Other aspects that could be part of an IBMS system include performance analytics which tie in automatic fault detection and diagnostic (FDD) applications to optimize the performance of the building systems. It provides on-going commissioning, keeping the largest energy consumption system at optimal performance.

#### 7.4.2 Dashboards

With a highly instrumented building, there will be lots of data which will become available. Data from sensors, meters, and databases will all provide the basis for not only energy management but also the overall comfort and well-being of occupants in the building. However, “raw” data is really not of any value unless it is processed, analysed and then combined with other pieces of data to establish some manner to “act” or control or make a change to improve.

In order to understand what data is available and the results of analysis, visualization of this information is paramount and this is normally provided in the form of some form of user interface (UI) or building dashboard. With the many different stakeholders in a building, there will be different “views” for dashboards. In the SFPUC, there are over 400 dashboards which provide the facilities team, building operators, executives, employees and even visitors with information specific to their needs. Users of this information then use this data to improve the building performance and operation.

#### 7.4.3 Analytics

A state of the art smart building typically will have analytics as part of the software suite along with the IBMS and dashboards. Once data is available in a building, the next step is to analyse the data and then determine how to improve the building performance using that data. This analysis is achieved through dedicated analytics software. Such software will help organize, manage, analyse data collected from various building systems and present them in a clear and concise manner via the dashboard. This provides a good insight into the operational performance of the building.

Analytics enables the operations and facilities teams of the building to find patterns and issues that they were not aware of, patterns that were not anticipated, expected or even imagined. Analytics provide results that show how the building actually operates versus how it was either designed to operate or expected to operate. Examples of benefits include immediate notification of system anomalies for proactive maintenance, building equipment lifecycle extension, reduction in energy consumption, identification of energy savings opportunities, and validation of energy savings.



## 8 Conclusions

---

Intelligent buildings are becoming more common, more complex and provide the ability for significantly reducing the environmental impact of our built infrastructure.

### 8.1 Vision

The ultimate vision of an intelligent building is one in which a very small group of individuals can monitor, manage, diagnose (and sometimes correct) most building operational issues without ever leaving their desks which are equipped with little more than a computer screen. Individuals given the right tools have the ability to monitor the security, the temperature, the lighting, the occupancy, the safety, the ventilation and the electrical consumption of the building. There is no longer a need for a patrol guard to move through the building in order to investigate if all individual doors are properly locked. As these systems become more trusted and more reliable the vision is that a smaller group of people can manage a large building autonomously, reliably and with traceability. The economies of reduced staffing, immediate response and operational statistics are significant. The ability to perform maintenance on the basis of actual hours used or defects which have been identified, will provide considerable savings. The ability to use electronic controls which ensure smooth starting and stopping of all machines, the gradual activation of luminaires and the smooth shutdown of luminaires all lead to significantly reduced operational failures and significantly extended operational life thereby providing further economies.

### 8.2 Future Considerations

Key areas that need to be addressed to gain the full benefit of intelligent building include:

- Understanding the goal of design and operation of an intelligent building.
- Is it more important that the building be more efficient, i.e. that the operating costs are reduced?
- Is it more important that the effectiveness of individual occupants in the building are put as the most important objective?
- Adoption of an appropriate communications protocol to operate with each of the ICT sub-systems through cooperation between all of the design engineers.
- Visioning a greater benefit in all aspects will accrue if a single building can enjoy the benefits of joining one building into multiple buildings thereby forming a community, a campus, or possibly even a city.
- The provision and ability to communicate over a common IP infrastructure, is a mechanism by which an intelligent building can be implemented. However, depending on the jurisdiction, there may be a need that some of the systems require special considerations in order to comply with all aspects of the building code, fire safety code or electrical code.
- Base building systems that are designed in a manner which permits their intercommunication and which also allows for communication between the building and individual tenant improvements.

Intelligent and sustainable buildings can form one of the pillars of a smart sustainable city. Buildings are a major contributor to global GHG emissions and the implementation of intelligence within our building stock can provide a method for reducing these emissions.

The ITU has a role to play in determining and facilitating the development of standards and protocols to ensure the intercommunication and interoperability of the ICT systems that make up an intelligent building which forms one of the foundations for a smart sustainable city. The ITU should continue to interact with other bodies and industry groups to ensure that the required standards for intelligent and sustainable buildings are developed. These standards need to be developed in concert with other "smart sustainable city" standards to ensure compatibility and seamless adoption.

## Abbreviations

This Technical Report uses the following abbreviations:

AHJ	Authorities Having Jurisdiction
ASHRAE	American Society of Heating, Refrigerating and Air-Conditioning Engineers
BAS	Building Automation Systems
BIQ	Building Intelligence Quotient
CABA	Continental Automated Building Association
CFS Alert	Canadian Forces Station Alert
DDC	Direct Digital Control
FG-SSC	Focus Group on Smart Sustainable Cities
Flint MTA	Flint Mass Transportation Authority
HVAC	Heating, Ventilating and Air Conditioning
IBT	Integrated Building Technology
ICT	Information and Communication Technology
IP	Internet Protocol
ITU	International Telecommunication Union
LEED	Leadership in Energy and Environmental Design
MRU	Multiple Rental Unit
PSIM	Physical Security Information Management
PWGSC	Public Works and Government Services
UPS	Uninterruptable Power Supplies
VAV	Variable Air Volume
WTCs	World Trade Centres

## Bibliography

- 1 Building Intelligence Quotient – <http://www.building-ig.com/big/index.html>
- 2 Building Owners and Managers Association of Canada – Building Environmental Standards Version 2 (BOMA BEST®) <http://www.bomabest.com>
- 3 Industry Canada Evaluation of the Technology Roadmap for Intelligent Building Technologies, (2005) [https://www.ic.gc.ca/eic/site/trm-crt.nsf/vwapj/intelligent\\_buildings-batiments\\_intelligents\\_eng.pdf/\\$FILE/intelligent\\_buildings-batiments\\_intelligents\\_eng.pdf](https://www.ic.gc.ca/eic/site/trm-crt.nsf/vwapj/intelligent_buildings-batiments_intelligents_eng.pdf/$FILE/intelligent_buildings-batiments_intelligents_eng.pdf)
- 4 Energy-Smart Buildings. (2011) (1st ed.). Retrieved from <http://www.accenture.com/SiteCollectionDocuments/PDF/Accenture-Energy-Smart-Buildings.pdf>
- 5 Jim, Sinopoli. (2012). The Smart Green Building (San Francisco Public Utility Sets and Example). Automatedbuildings.com. Retrieved 29 December 2015, from <http://www.automatedbuildings.com/news/may12/articles/sinopoli/120426043003sinopoli.html>
- 6 Joneslanglasalle.com, (2015). Global-Property-Sustainability-Perspective-Q4-2014-A-Sustainable-Campus-in-Hyderabad. Retrieved 15 February 2014, from <http://www.joneslanglasalle.com/GSP/en-gb/Pages/Global-Property-Sustainability-Perspective-Q4-2014-A-Sustainable-Campus-in-Hyderabad.aspx>
- 7 Kamath, R. (2014). Infosys awarded highest LEED rating for two buildings in Hyderabad – InformationWeek – IT news & articles. Informationweek.in. Retrieved 13 February 2015, from <http://www.informationweek.in/informationweek/news-analysis/287292/infosys-awarded-leed-rating-buildings-hyderabad>
- 8 Kmdarchitects.com, (2012). KMD Architects: Press Room | KMD in the News » New SFPUC Headquarters Tour Features LEED Platinum Features. Retrieved 20 October 2014, from <http://www.kmdarchitects.com/pressroom/in-the-news/new-sfpuc-headquarters-tour-features-leed-platinum-features/>
- 9 Kurmanath, (2012). Infosys Hyderabad building gets green tag. The Hindu Business Line. Retrieved 8 February 2015, from <http://www.thehindubusinessline.com/industry-and-economy/info-tech/infosys-hyderabad-building-gets-green-tag/article3332685.ece>
- 10 Sustainablewater.com, (2015). San Francisco Public Utilities Commission Headquarters one of AIA's top 10 Green Buildings for 2013 | Sustainable Water. Retrieved 6 March 2015, from <http://sustainablewater.com/san-francisco-public-utilities-commission-headquarters-one-of-aias-top-10-green-buildings-for-2013/>
- 11 Infosys 3.0 Accelerating growth. (2012) (1st ed.). Retrieved 01 February 2015, from <http://www.infosys.com/investors/reports-filings/annual-report/annual/Documents/Infosys-AR-12.pdf>
- 12 Microsoft Sustainability Fact Sheet (2008) Retrieved 02 April 2015 from <http://download.microsoft.com/download/f/8/f/f8f0fc33-3c5d-4fd8-a36e-348543f3539f/SustainabilityFactSheet.doc>









# 3.6

## Smart water management in cities

Technical Report



## Acknowledgements

This Technical Report was researched and written by Paolo Gemma (Huawei), Ziqin Sang (Fiberhome Technologies Group), Amanda McIntosh (Carlo-Schmid Programme) and Angelica V Ospina (University of Manchester) as a contribution to ITU-T Focus Group on Smart Sustainable Cities (FG-SSC) and ITU-T Focus Group on Smart Water Management (FG-SWM).

The authors would like to thank ISO/TMB Smart Cities AG for their valuable comments and contributions.

Additional information and materials relating to this report can be found at: [www.itu.int/itu-t/climatechange](http://www.itu.int/itu-t/climatechange). If you would like to provide any additional information, please contact Cristina Bueti at [tsbsg5@itu.int](mailto:tsbsg5@itu.int).

## Table of Contents

	<b>Page</b>
<b>1 Introduction .....</b>	<b>503</b>
<b>2 Scope.....</b>	<b>505</b>
<b>3 Urban water issues .....</b>	<b>506</b>
3.1 Rapid urbanization .....	507
3.2 Leadership and governance .....	508
3.3 Investment.....	508
3.4 Water utilities and infrastructure.....	509
3.5 Water availability and quality.....	510
3.6 Climate change .....	511
<b>4 Smart water management in cities .....</b>	<b>513</b>
4.1 SWM technologies.....	515
<b>5 SWM integration: Strengthening urban water management .....</b>	<b>524</b>
5.1 Intelligent solutions in urban water management.....	524
5.2 Remote monitoring solutions to urban wastewater management .....	527
5.3 Technologies for urban flood management.....	528
<b>6 Action steps: SWM implementation .....</b>	<b>530</b>
<b>7 SWM opportunities .....</b>	<b>531</b>
<b>8 Gaps to be addressed .....</b>	<b>533</b>
<b>Conclusions .....</b>	<b>535</b>

## List of Figures

	<b>Page</b>
Figure 1 – Interconnectedness of water and cities.....	503
Figure 2 – Influencing factors on urban water management challenges .....	506
Figure 3 – Projected megacities, 2015.....	507
Figure 4 – Projecting water stress.....	511
Figure 5 – Climate change effects on urban water resources .....	512
Figure 6 – Advantages of smart water management .....	514
Figure 7 – Schematic representation of smart water management technologies and tools..	515
Figure 8 – Current implementation of smart water management technologies and tools ....	515
Figure 9 – Smart meter technologies.....	518
Figure 10 – Example of SCADA software, Western Municipal Water District (WMWD), California.....	520

	<b>Page</b>
Figure 11 – Example of web-based technologies and city flooding: The Brisbane City web-based flood map .....	522
Figure 12 – The AWRIS system.....	524
Figure 13 – Screenshots of AQUADVANCED interfaces.....	525
Figure 14 – The BIT PipeScanner, 2nd generation .....	526
Figure 15 – WaterMOLE, 2nd generation .....	527
Figure 16 – Options investigated within Delft-FEWS real-time control of sewer system pilot project.....	528
Figure 17 – Screenshot of the INFUX interface.....	529
Figure 18 – RainGain project location.....	529
Figure 19 – Steps towards the implementation of SWM .....	530
Figure 20 – Key actions involved in the implementation of SWM .....	531
Figure 21 – Smart water management tools .....	532

## Smart water management in cities

### Executive Summary

From their inception, information and communication technologies (ICTs) have played a pivotal role in the lives of cities. Historically, cities have been generating economic growth by developing institutions and assembling human resource to achieve prosperity, but unfortunately, this was often done at the expense of their water resource base. With rapid urbanization becoming an inevitable fact, cities are facing increasing challenges to secure financially sustainable water and sanitation services for its citizenry. If matched with appropriate and effective ICT solutions, in the form of smart water management (SWM), water issues within cities can be properly addressed and managed.

Smart water management (SWM) in cities seeks to alleviate challenges in the urban water management and water sector through the integration of ICT products, solutions and systems in areas of water management and sanitation, as well as stormwater management. Such technologies are adapted to continuously monitor water resources and diagnose problems in the urban water sector, allowing to prioritize and to manage maintenance issues more effectively, as well as to gather data needed to optimize all aspects of a city's water management system and feed information back to citizens, water operators, and technical services of cities.

Recognizing the impact that SWM can have at the intersection of water issues, growing cities, and increasing climate change impacts, the International Telecommunication Union (ITU) established a Focus Groups on Smart Water Management (FG-SWM) and Smart Sustainable Cities (FG-SSC), with the vision that novel ICT-enabled tools can help empower regions, countries, and cities to overcome water-related challenges. Consequently, ITU has been at the forefront of emerging explorations on the potential of SWM in the alleviation of global challenges associated with this resource.

By promoting the coordinated development and management of urban water, SWM allows cities to strengthen institutional capacities, while striving to improve the sustainability of its natural resource base, particularly with respect to water and the environment. However, careful design and proper coordination among all relevant sectors – from the initial stages of project design, to implementation and assessment – is crucial to realize these opportunities.

This Technical Report aims to provide an overview of the key issues involved in SWM within urban settings, including the key water management problems and opportunities faced by cities. By highlighting the role and potential of ICTs, this Technical Report seeks to position SWM as a crucial area of action to achieve the goals set out by smart sustainable cities, and to respond to ongoing and emerging urban challenges, including those posed by climate change.

This Technical Report is structured around seven sections. The first section provides a general background of the analysis, highlighting the interconnectedness between water resources and cities, and situates the potential of ICTs and SWM. The second section provides a more in-depth understanding of urban water issues affecting urban settings, identifying the role of rapid urbanization, water availability and quality, water utilities and infrastructure, climate change impacts and investment needs. The third section explores smart water management in cities, providing an overview of key SWM technologies designed to improve performance, increase efficiency, lower cost and reduce potential environmental impacts, among others. The fourth section links theory to practice by providing selected examples of SWM solutions for urban water

management, wastewater management and flood management. Building on this basis, the last three sections of this Technical Report suggest a set of concrete actions towards the implementation of SMW in cities (section five), the identification of the key opportunities associated with ICT-enabled solutions in the water sector (section six), and acknowledgement of the main gaps that need to be addressed to fully realize their potential in this field (section seven).

By offering analytical and technical insights into urban water issues and the role of ICT tools, this Technical Report seeks to stimulate further dialogue and discussion among the diverse stakeholders, practitioners and decision-makers interested in this field.

## 1 Introduction

The Water cycle (water resource, production, distribution, consumption, collection and treatment of waste water) play an integral part of the urban system, influencing each pillar of the urban society and its functionality, sustaining populations, generating energy, supporting tourism and recreational activities, ensuring environmental and human health, and fuelling local economic development. Such increasing convergence fosters urban growth, as more than half of the world's population currently reside in urban areas<sup>1</sup>. It is estimated that urban populations will increase from 3.6 billion in 2011, to 6.3 billion in 2050<sup>2</sup>. Urban areas will also have the task of absorbing rural populations, as their growth continues to decline.

As illustrated in Figure 1, the availability and distribution of water resources is intrinsically linked to the city's operations in areas as diverse as housing, health, economic development, tourism, recreation, transport, waste management and energy.



Source: Howe *et.al.* (2011).<sup>3</sup>

**Figure 1 – Interconnectedness of water and cities**

The increasing concentration of people, economic activities and assets in urban areas usually generates high amounts of waste and greenhouse gas pollution, heightening the city's susceptibility to the risks posed by disasters/hazards, as well as to the impacts of climate change. Thus, unbridled growth in urban areas poses socio-economic and environmental challenges to residents, businesses, industries, municipalities and governments alike. As per the focus of this Technical Report, it also poses significant challenges to urban planners in terms of effective and sustainable water management.



These challenges include the stress placed on water resources by fast-paced urbanization rates, which translates into a growing demand for clean water supplies and adequate sanitation, required to ensure human dignity. Rapid urban growth has also increased the competition for scarce water resources between sectors such as industry and agriculture.

The OECD report 'Water Security for Better Lives', suggests that achieving water security objectives means maintaining acceptable levels for four water risks: risk of shortage (including droughts), risk of inadequate quality, risk of excess (including floods), and risk of undermining the resilience of freshwater systems (e.g. by exceeding the coping capacity of the surface and groundwater bodies). This approach evidences an increasing awareness of the importance of tackling water-related challenges from an integrated, holistic perspective, considering both acceptable levels of risks, as well as their potential consequences (economic, environmental, social) on urban stakeholders.

The urban water service must, therefore, ensure proper management of water supply and distribution, water and wastewater treatment, and other municipal related services. Through franchising or licensing model franchises, the urban water industry is able to provide water and wastewater services for cities. The urban water utilities are constantly extending the water service chain, including (but not limited to) the following areas:

- **Raw water service:** diversion of raw water is necessary to facilitate treatment and distribution to a city's population. In some cities, retail water price includes water diversion project costs.
- **Water supply services:** provision of safe treated water to various sectors within the urban environment, including the residential, commercial, and industrial sectors.
- **Drainage services:** provision of urban drainage through pipe networks is important to safeguard public health and prevent flooding. Some cities have separated their drainage network operation as a type of commercial service by an open bid for franchise of drainage service.
- **Wastewater treatment services:** provision of wastewater treatment for commercial/marketed services is necessary to ensure environmental protection.
- **Reclaimed water service:** usually offered by the vast majority of sewage treatment companies as a value-added business to industrial customers/users such as power plants.
- **Other water supply services:** the sea-water desalination market is in transition from an engineering, procurement, and construction (EPC) equipment provision to an integral investment and operational service.

With such a heavy reliance on water resources (Figure 1), any reductions on quantity or quality will have an adverse effect on the urban system. With the cities increasing their centralized production and consumption, and the rapidly changing land use patterns, the sustainable management of water resources constitutes a complex issue. Balancing economic development and water resource sustainability becomes even more problematic considering the current and expected impacts of climate change (e.g. sea level rise, water scarcity), added to the vulnerability associated with aging infrastructure.

Within this context, smart water systems can be characterized as systems with "a high degree of automation, rapid response times or the capability to capture information in real-time, the ability to transmit data between remote locations and the data processing facility, and for the data to be interpreted and presented to utilities and end users" (OECD, 2012, p. 4)<sup>4</sup>. While these systems combine both technical and non-technical innovations, information and communication technologies (ICTs) are increasingly providing novel operational possibilities to urban water managers.

Smart water management (SWM) approaches seek to promote a sustainable, well-coordinated development and management of water resources through the integration of ICT products, tools and solutions; thus providing the basis for a sustainable approach to water management and consumption.

The low cost of some ICT products, as well as their fast turnover rates when applied to urban environments, is fostering new and innovative approaches to ensure safe and adequate water provision for city dwellers. These technologies can be adapted to continuously monitor and diagnose problems, prioritize and manage maintenance issues, and use data to optimize all aspects of the urban water management network.

Harnessing the potential of ICTs in cities through the use of SWM can contribute to overcome water related socio-economic, cultural and environmental challenges, as well as to equip cities with technology to mitigate the impacts of climate change.

Building on this basis, this Technical Report explores the key issues involved in SWM within urban settings, including the key water management problems and opportunities faced by cities. By highlighting the role and potential of ICTs, this Technical Report seeks to position SWM as a crucial area of action to achieve the goals set out by smart sustainable cities, and to respond to ongoing and emerging urban challenges.

## 2 Scope

---

This Technical Report provides municipalities, decision-makers and interested stakeholders with an overview of the main technical aspects that need to be considered to effectively design and implement smart water management in cities. This Technical Report approaches smart water management systems from an overarching perspective. Therefore, it is expected that the smart water technologies described, as well as their integration into urban water management systems, can be relevant to inform the design of new systems (e.g. in the case of rapid urban growth and infrastructure extension in developing countries), as well as to update existing systems (e.g. linked to declining per capital demand for water and ageing infrastructure in developed countries).

While currently most water services (including drainage) rely on piped infrastructures, decentralized and non-piped water management techniques are starting to diffuse in both developed and developing cities. Given the scope of this Technical Report, the analysis focuses on the former. Further studies on the role of ICTs in decentralized water infrastructures could be the object of future work of ITU's Focus Group on Smart Water Management (FG-SWM).

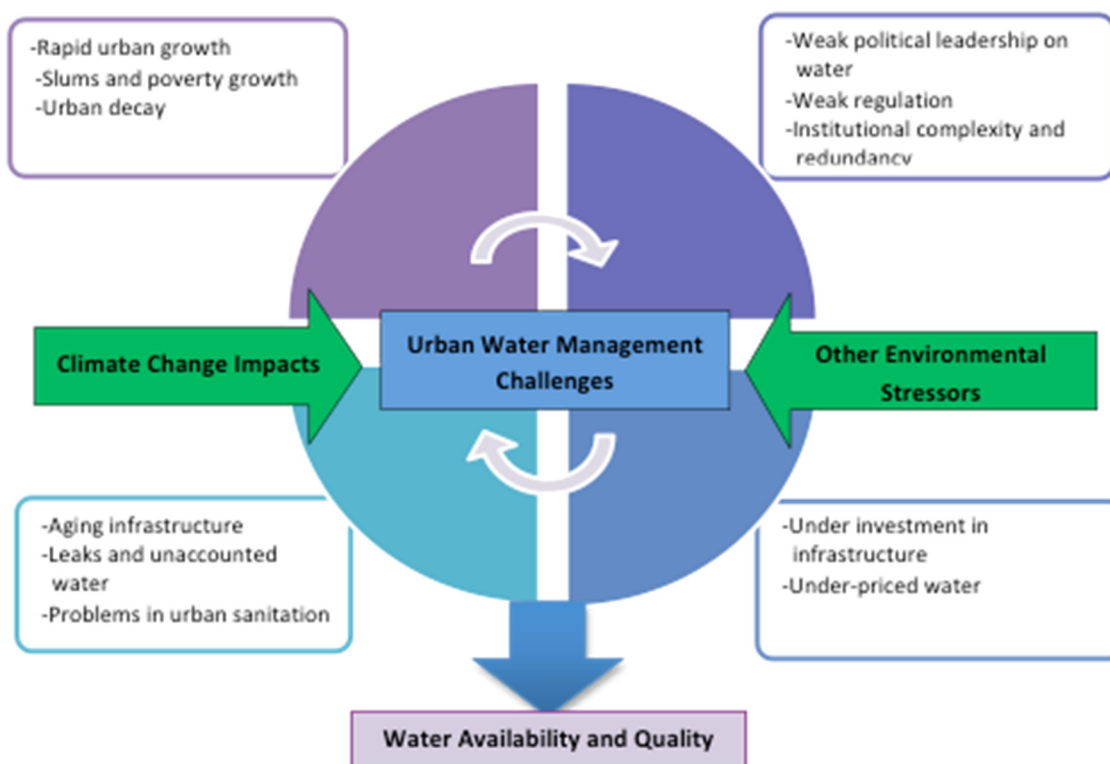
Building on the efforts of Working Group 2 of the Focus Group on Smart Sustainable Cities (FG-SSC), this Technical Report offers both analytical and technical insights into urban water issues and the role of ICT, seeking to stimulate further dialogue and discussion among decision-makers, practitioners and experts working in this field.

In order to better understand the potential of ICT tools as part of SWM, the first section of this Technical Report explores the key challenges faced by cities in regards to water cycle, emphasizing those that are exacerbated by the impacts of climate change.

### 3 Urban water issues

Cities rely on multiple utility infrastructure systems that are characterized by their complexity, as well as by high investment and management costs. In the years ahead, it is expected that cities and other urban centres will encounter resource distribution challenges associated with an increase in population flow, energy issues due to the depletion of fossil fuel resources, increased investment overheads, spiralling maintenance and management costs due to aging infrastructure and improper land resource utilization, among others. Innovative and new sustainable systems are essential to minimize the impact of these emergent challenges.

Based on the context presented thus far, the provision of clean and reliable water constitutes a key area for the functioning of urban systems. Rapid urbanization, poverty and urban decay, weak political leadership and governance, insufficient and inadequate infrastructure, under investment and pricing issues, are among the key, and mutually re-enforcing factors that impinge upon a city's water management system. These factors are further exacerbated by the impacts of climate change and other environmental stressors, ultimately heightening water management challenges, and constraining the availability and the quality of urban water resources. The interconnected and dynamic nature of urban water management challenges is illustrated in Figure 2.



Source: Adapted from McIntosh (2014).<sup>5</sup>

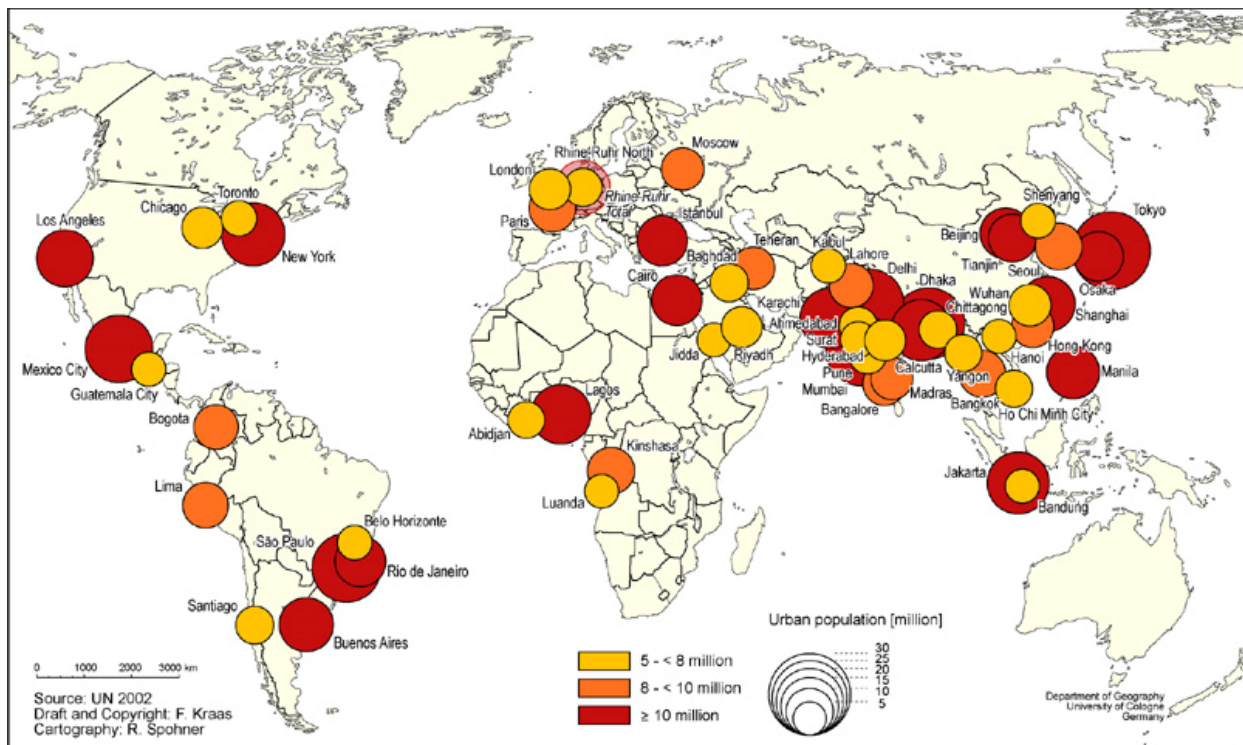
**Figure 2 – Influencing factors on urban water management challenges**

This figure suggests that the impacts of climate change, among other stressors, exacerbate the complex set of challenges that affect urban water management systems (e.g. aging infrastructure, urban sanitation problems). At the same time, these challenges impinge upon the effectiveness of water management systems to prepare for, withstand, recover and adjust to these impacts. In order to understand better the linkages between these challenges and water management, the following section explores some of the key factors that influence urban water management.

### 3.1 Rapid urbanization

Cities around the world are continuously providing financial and specialized services for businesses, industry, and manufacturing sectors, among others. The emergence of new markets has contributed to a sharp population increase, fostering urbanization. The global urban population is estimated to be 3.5 billion of inhabitants, and is expected to surpass 5 billion by 2030<sup>6</sup>. This rapid growth engulfs outlying towns and blurs rural/urban boundaries creating peri-urban areas, areas immediately adjoining urban areas that are localized outside formal urban boundaries and urban jurisdictions, and in some regions, urban corridors, city chains and megacities.

Megacities and metacities – defined by the UN-Habitat as cities with more than 10 million inhabitants or 20 million inhabitants respectively – are growing rapidly, particularly in developing countries of Asia, Latin America and Africa<sup>7</sup>. It is estimated that by 2025 there will be 27 megacities, 21 of which will be located in developing countries. Projections suggest that by 2015, Bombay (22'6 million inhabitants), Dhaka (22'8), Sao Paulo (21'2), Delhi (20'9) and Mexico City (20'4) will be among the six biggest megacities, each surpassing 20 million inhabitants<sup>8</sup> (Figure 3).



Source: Kraas and Nitschke (2008).<sup>9</sup>

**Figure 3 – Projected megacities, 2015**

These highly concentrated populations and the increasing size of cities have posed severe strains in local water resources, as cities are confronted by the need to meet an increasing demand for water resources. In the case of many cities, responding to this high demand has led to unsustainable water usage and over abstraction, and a depletion of groundwater and rivers that has serious consequences on water sources and on the environment. These challenges can have severe effects in megacities located in arid and semi-arid areas, particularly as climate change impacts further constrain their ability to provide access to a reliable and clean supply of water.

The inability to provide citizens with the necessary infrastructure has caused other problems, including the growth of the informal supply of drinking water, wastewater collection and disposal

systems. These informal systems operate largely unregulated, posing major health risks to the population. Pressures to respond to this increasing demand have led cities to import water resources, contributing to increase urban carbon emissions.

### 3.2 Leadership and governance

Sustainable policies, strategies and practices are necessary to respond to the challenges affecting urban water resources. However, weak regulatory water and sanitation frameworks, along with overlapping functions within governmental agencies and institutions, have led to an unclear division of responsibilities and to uncoordinated efforts in urban water management. This has caused the fragmentation of strategies, as well as redundancies, jurisdictional conflicts, wastage of resources and conflicts in financing, resulting in inefficient and unsustainable approaches to urban water management in many cities around the globe. Heavy subsidies and fixed rates implemented by governments have encouraged ineffective usage and high consumption rates of water resources, ultimately placing further stress on this fragile resource.

Adding to these challenges, sectoral politicization has fostered short-term decision-making, while management goals and strategies are often limited to the term of the elected government. Insufficient capacity development and outdated management practices cause decisions to be made with inadequate information, or lead to poor implementation. Without capable staff and relevant information, the adoption of novel technology solutions needed to enhance a city's water management becomes unfeasible. Weak leadership and governance within the urban water structure has limited the sector's capacity to effectively address many of the existing and emerging challenges related to water resources.

Some of these challenges are explored in OECD's report 'Water Governance in OECD Countries: A Multi-level Approach'<sup>10</sup>, including the co-ordination "gaps" that exist in water policy, multi-level governance challenges in decentralized public policy, and relevant policy responses. The OECD study suggests that the implementation of performance measurements, water information systems and databases, financial transfers, inter-municipal collaboration, citizen participation and innovative mechanisms (e.g. experimentation) are important tools for better co-ordination of water policy at the territorial level, and between levels of government.

### 3.3 Investment

Urban water management cannot be effective without the investment needed for a comprehensive, system-wide implementation. Increasing urbanization poses the need for new infrastructure to satisfy the requirements of the present as well as the future. The high cost and substantial investment requirements for the establishment and operation of such services has led to shifting responsibilities between governments and municipalities (e.g. jurisdictional financing conflicts), governments and industries/businesses (e.g. polluter pay effect), as well as between governments and the public (e.g. underpriced water due to insufficient tariffs) in order to generate the revenue and payment systems needed to finance urban water investments.

Consequently, the financing of water and sanitation services constitutes a major issue. The fact that aging infrastructure is crippling urban water distribution systems is a clear indicator that there is insufficient financing and investment within the urban water structure. To ensure a sustainable development of water infrastructure, appropriate investment levels are needed to support both short- and long-term decision-making, and to address the uncertainty and emerging risks associated with urban water challenges.



### 3.4 Water utilities and infrastructure

The rate of urbanization in some cities exceeds the capacities of governments (both local and national) to effectively plan and transition in an efficient and sustainable manner. Since the infrastructure design and capacity of water distribution and treatment plants are reliant on forecasted water demands and socio-economic data, unforeseen urban growth can lead to severe inequalities in service provision, thus constraining public access to water and sanitation.

Population growth in developing countries is often accompanied by increasing socio-economic challenges. For most cities in the developing world, a lack of revenue has translated into the lack of investment, limiting the city's ability to repair deteriorating infrastructure or improve aging facilities, while fostering the spread of informal infrastructure. Aging infrastructure is one of the most pressing concerns for the water utility industry. Statistics suggest that metallic water pipes failure rates range from 0.1 and 0.9 breaks per km and year<sup>11</sup>. According to the American Water Works Association, simply restoring existing water systems will cost over USD 1 trillion over the next 25 years<sup>12</sup>. Water lines, sewer mains, and treatment plants in cities, many built over a hundred years, are either leaking, collapsing, or overflowing, and it is estimated that 40% of clean water is lost yearly due to leaks with non-revenue water accounting for approximately USD 14 billion lost annually<sup>13</sup>.



Water losses are also linked to illegal connections within the distribution network, as high amounts of non-revenue water means that a large portion of revenue is not always claimed from the customers. With the high cost of constructing, operating and maintaining water supply pumping, treatment and distribution infrastructure, and water utilities unable to recover these costs, a growing number of cities are facing serious challenges in the provision of safe and adequate water/sanitation.

While this section has focused on water utilities, it is important to recognize that urban water management encompasses a more diverse group of institutions and stakeholders, including property developers and households that invest in green roofs or buy water-efficient appliances. Further information on the role of these varied stakeholders in the implementation of SSC strategies can be found in other Technical Reports prepared by ITU FG-SSC (e.g. Smart Buildings for Smart Sustainable Cities, SSC Stakeholders)<sup>14</sup>

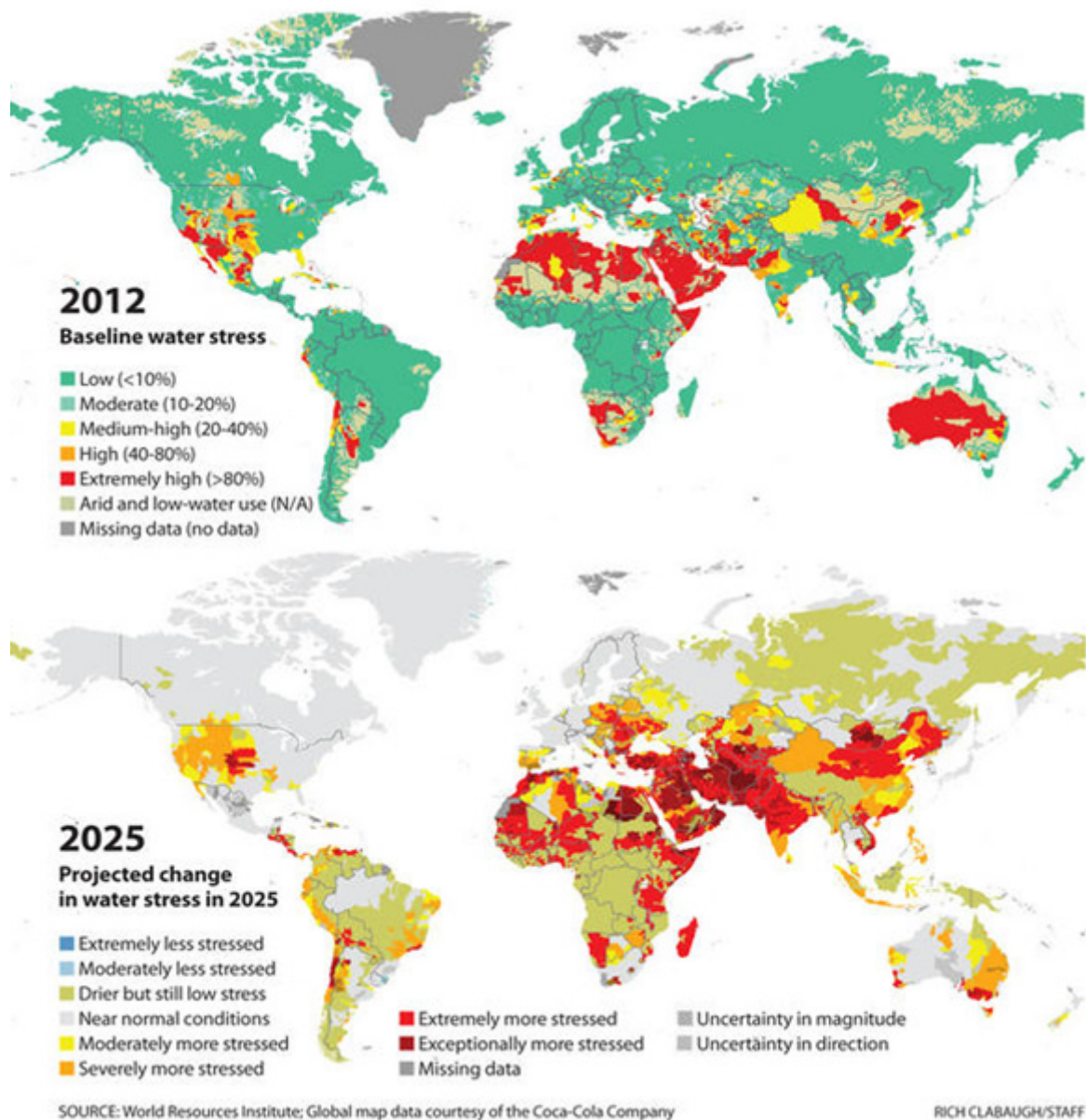


### 3.5 Water availability and quality

Urban water sources are very diverse. They include rivers, lakes, reservoirs, groundwater, desalination plants or a mixture of these sources. In many metropolitan areas, however, due to the growth of urbanization, the supply may extend far beyond the city's watershed. Such large cities rely heavily on a regional scale supply and distribution system. This is further complicated as freshwater is unevenly distributed over space and time, which places major planning and management challenges to the water sector. Approximately 700 million people in 43 countries are currently suffering from water stress and scarcity<sup>15</sup>, with over 1 billion people without access to clean water<sup>16</sup>, and over 2.6 million lacking adequate sanitation facilities<sup>17</sup>.

In developing countries, poor water and sanitation facilities are the source of health problems for almost half of the population, and can be linked to 80% of diseases<sup>18</sup>. Urban pollution has also gradually led to the deterioration in water quality. Only 10% of the world's cities currently have water treatment facilities, and 90% of untreated wastewater in developing countries is discharged into rivers<sup>19</sup>, further decreasing the availability of clean water resources for urban inhabitants. Therefore, providing a clean supply of water is considered to be both challenging and expensive.

Considering existing gaps in water demand and distribution, climate change impacts and poor water management magnify the vulnerability of countries that are experiencing water stress and weak water infrastructure. Water scarcity is not only a threat to human and economic development, but it may become a source of political instability in years to come. Illustrating the magnitude of water-related vulnerability at the global level, Figure 4 provides a baseline of water stress and projected changes by 2025. Climate change-related stressors on the urban water management are explained below.



Source: World Resources Institute (2014).<sup>20</sup>

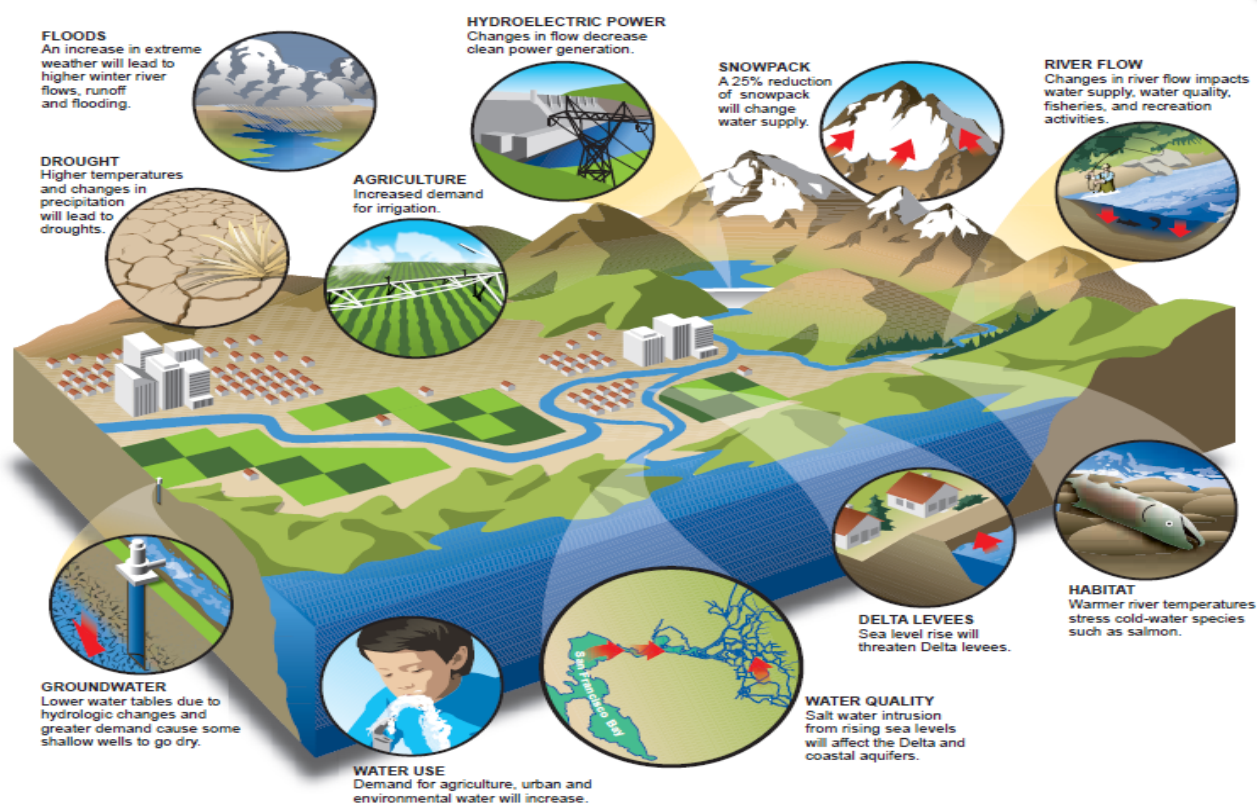
**Figure 4 – Projecting water stress**

### 3.6 Climate change

Data from the Intergovernmental Panel on Climate Change (IPCC)<sup>21</sup> climate change is projected to alter the frequency and magnitude of both floods and droughts. The impact is expected to vary from region to region. Some studies suggest that flood hazards will increase over more than half of the globe, in particular in central and eastern Siberia, parts of Southeast Asia including India, tropical Africa, and northern South America, but decreases are projected in parts of northern and Eastern Europe, Anatolia, central and East Asia, central North America, and southern South America (*limited evidence, high agreement*). These impacts are expected to impinge on water storage, decrease water quality and threaten urban water infrastructures, while disrupting service and increasing energy costs for operation and maintenance at both the local and the regional levels.

Since variation in precipitation regimes can cause severe droughts or lead to flooding, the increase in the frequency and intensity of droughts will negatively affect reservoir and groundwater storage. Towns and cities where the average level of rainfall is declining may experience precipitation in shorter, more intense bursts which can overwhelm urban drainage systems, leading to more street, basement, and sewer flooding. Sewerage systems that support storm water runoff, wastewater and sewage would be overwhelmed, endangering public health.

Cities, megacities and peri-urban areas are therefore highly vulnerable to climate change and its potential impact on its urban water systems. Cities in transboundary basins will be at higher risk, since inadequate management could intensify water stress. Figure 5 sums up the effects that various climate change manifestations are expected to have on urban water resources.



Source: Major et al. (2011).<sup>22</sup>

**Figure 5 – Climate change effects on urban water resources**

Sea level rise poses even a larger threat to coastal cities, which accounts for three-quarters of all large cities and half the world's population (UNEP and UN-Habitat, 2005). Salt water intrusion is expected to contaminate coastal surface water sources, and groundwater sources, decreasing thus their quality. An increase in sea level is also expected to lead to an increased probability of flooding of sewerage systems and wastewater pollution control plants (WPCPs), and to a reduced ability to discharge combined sewer overflows (CSOs) and WPCP effluent by gravity.

The analysis presented thus far suggests that climate change will exacerbate the city's vulnerability in terms of both the quantity and the quality of water resources. Based on this context, the following section will explore smart water management in cities, identifying the technologies that can be used to respond to the main challenges faced by cities in both the developed and developing countries.

## 4 *Smart water management in cities*

---

Water management is closely associated with water resource development and environmental protection, and it also entails proper management of the demand for public services and cost effectiveness. Consequently, urban water management must ensure access to water and sanitation infrastructure and services, manage rain, waste and storm water as well as runoff pollution, mitigate against floods, droughts and water borne diseases, while at the same time safeguarding the resource from degradation. As identified in the previous section, accelerated urbanization, especially in the developing world, coupled with increasing concerns for water security in the face of climate change and aging infrastructure, have challenged the effective implementation of these provisions. In today's integrated global economy, innovations in telecommunications have created a valuable opportunity to address these water challenges within cities, whilst improving urban water management.

Recognizing the challenges faced by the water sector, stakeholders from academia, corporations and the ICT sector have developed water intelligence tools that use ICTs to alleviate global water issues. The role played by smart water systems in optimizing the efficiency, effectiveness and flexibility of water and wastewater infrastructure assets and their management constitutes a topic of increasing attention, as evidenced in a recent OECD inventory of policies to promote and facilitate the diffusion of these technologies<sup>23</sup>.

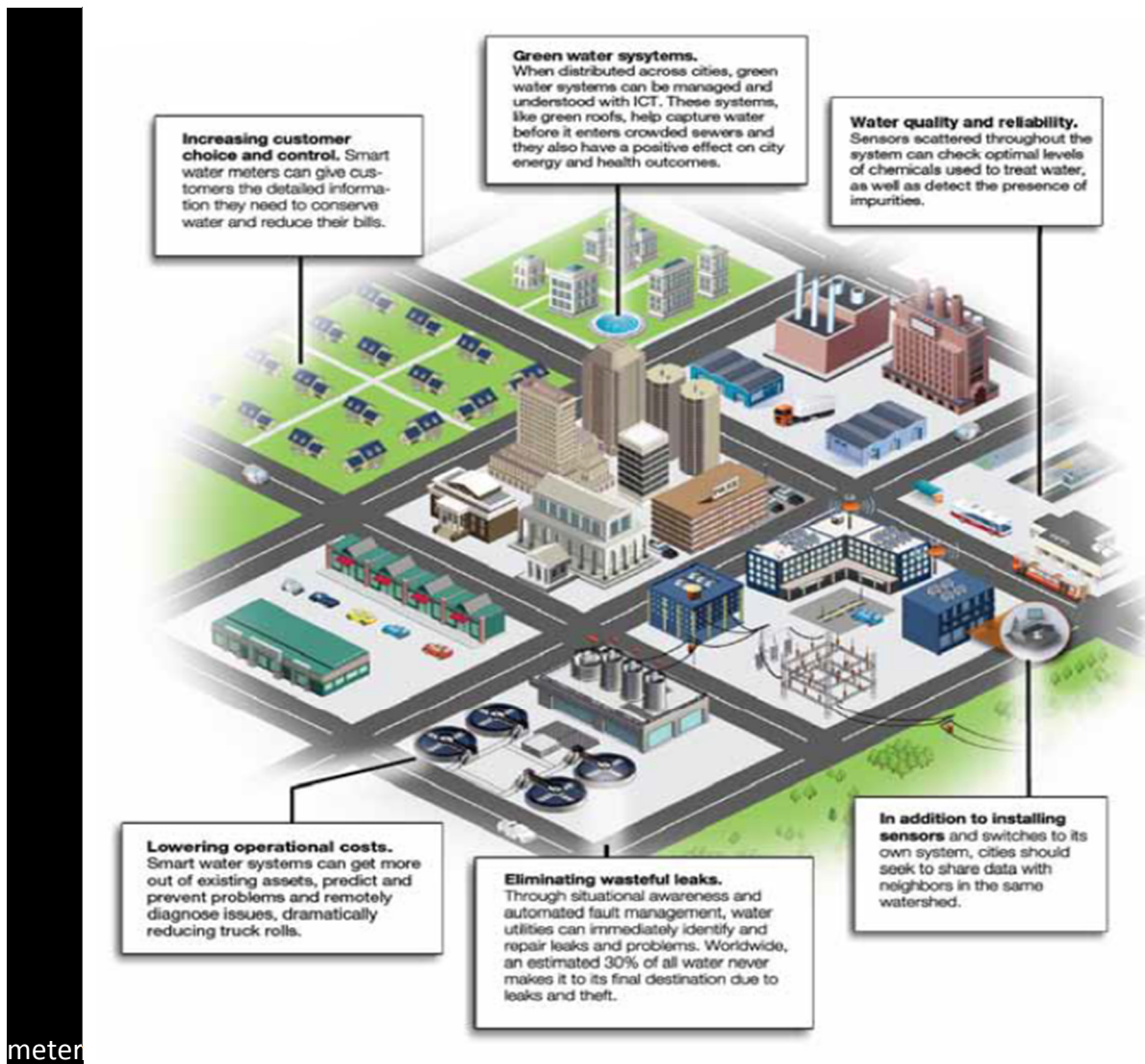
ICTs offer valuable opportunities to improve the productivity and efficiency within the water sector, with the aim of contributing to the sustainability of the resource. These technologies allow the continuous monitoring of water resources, providing real-time monitoring and measuring, making improvements in modelling and problem diagnosis, thus enabling proper maintenance and optimization of all aspects of the water network.

The increasing availability of more intelligent, ICT-enabled means to manage and protect the planet's water resources has led to the development of smart water management (SWM). The SWM approach promotes the sustainable consumption of water resources through co-ordinated water management, by integrating ICT products, solutions and systems, aimed at maximizing the socio-economic welfare of a society without compromising the environment. SWM can be applied to multiple sectors (e.g. industries, agriculture) and urban environments.

In cities, SWM strives to achieve three main goals through the utilization of ICTs, namely: (a) co-ordinated water resource management and distribution, (b) enhanced environmental protection, and (c) sustainable provision of public services and economic efforts.

Within urban environments, the implementation of SWM can make significant improvements in water distribution, helping to decrease losses due to non-revenue water, and helping to enhance waste- water and storm water management. Figure 6 illustrates the role of SWM water quality and reliability, ensuring proper management of green systems, decreasing water loss due to leakage, reducing operational costs, and improving customer control and choice. These improvements increase the efficiency of the water sector, while contributing to its economic sustainability since municipalities and water utilities are better able to recover costs from non-revenue water, including the detection of illegal connections.



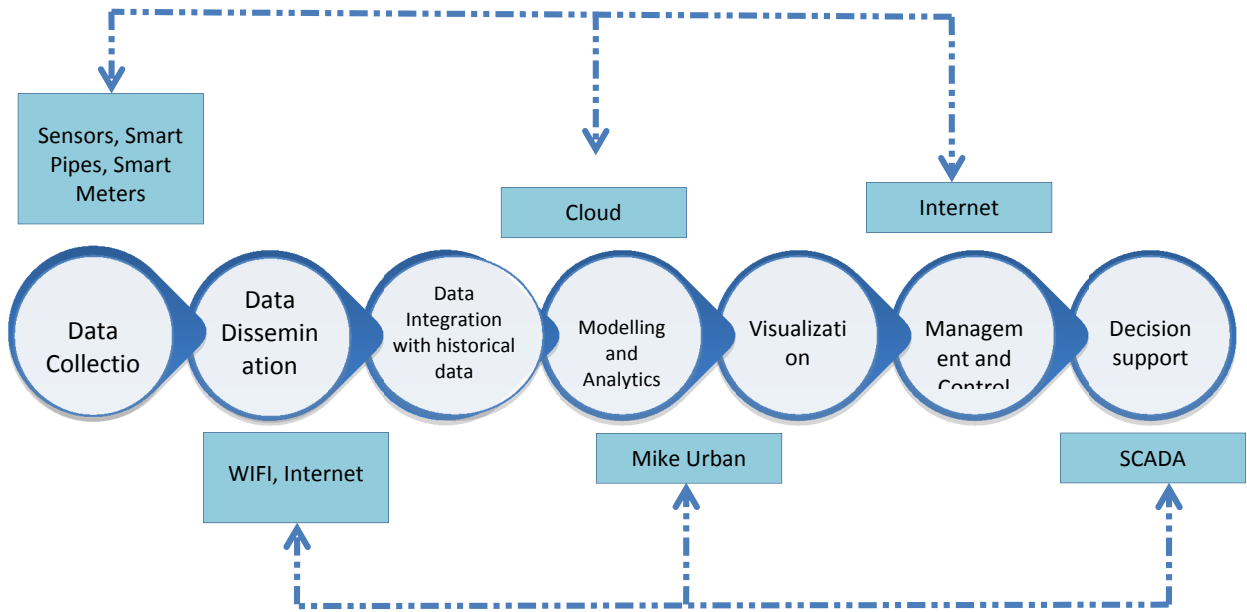


Source: Berst *et al.* (2013).<sup>24</sup>

**Figure 6 – Advantages of smart water management**

SWM tools can be categorized in the six main areas listed below. It should be noted that the examples provided are not limited to these areas, but may overlap several others, as seen in Figure 7.

1. Data acquisition and integration (e.g. sensor networks, smart pipes, smart meters).
2. Data dissemination (e.g. radio transmitters, wireless fidelity (Wi-Fi), Internet).
3. Modelling and analytics (e.g. geographic information system (GIS), Mike Urban, Aquacycle, assessing and improving sustainability of urban water resources and systems (AISUWRS), and urban groundwater (UGROW)).
4. Data processing and storage (e.g. software as a service (SaaS), cloud computing).
5. Management and control (e.g. supervisory control and data acquisition (SCADA), optimization tools).
6. Visualization and decision support (e.g. web-based communication and information systems tools).
7. Restitution of data and information to cities' technical services and to the end users (e.g. Tools for sharing information on water and on services).

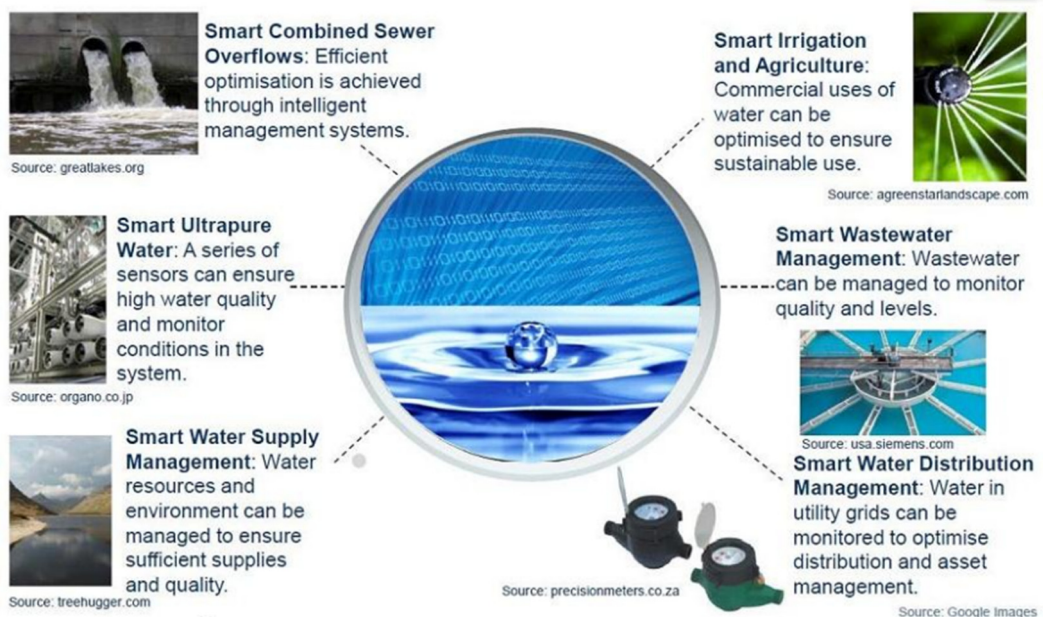


**Figure 7 – Schematic representation of smart water management technologies and tools**

As illustrated in Figure 7, SWM technologies often overlap a series of functionalities that are key for the effective operation of urban water systems. The following section will explore in more detail the role of each of these technologies, and their contribution to SWM.

**4.1 SWM technologies**

Smart water Management technologies are currently applied to many different areas of water management, as illustrated in Figure 8.



Source: Hauser (2012).<sup>25</sup>

**Figure 8 – Current implementation of smart water management technologies and tools**



When applied to cities, the availability of reliable data to enhance operations can improve decision-making at multiple levels. Many innovative ICT tools have been developed in support of next-generation urban water infrastructure systems, helping to improve performance, increase efficiency, and reduce costs, decrease redundancy, and lower environmental impacts, among others. Some of these smart technologies are explained below:

**a. Smart pipes and sensor networks**

Smart pipes incorporate multifunctional sensors that can sense strain, temperature and pressure anomalies, as well as measure water flow and quality during service, to provide operators with continuous monitoring and inspection features, while assuring safer water supply distribution. Connecting smart pipes with a wireless processor and antenna enables data to be transferred directly to a command centre, providing water managers with the tools needed to detect and locate potential leaks in real time.

Smart pipes were initially developed for the transportation of oil, gas and hazardous liquids. Over the years, their applicability to water networks has slowly been realized. New research and development in prototypes for water distribution are needed to continue to advance public water supply systems<sup>26</sup>.

Wireless sensor networks provide the technology for cities to more accurately monitor, and sometimes control, their water supply systems intricately using different parameters. Examples include sensors with the ability to analyse the acoustic signature of a pipe or to monitor soil moisture and detect leaks (e.g. if the ground is absorbing water, it could be an indication of a pipe leak; if the minimum daily noise is increasing it also means that a small leak was recently created). Many ICT companies are developing a wide range of sensors specifically designed for water networks. Some smart sensors can detect flow rates down to 0,3 m<sup>3</sup>/hr (5 liters/minute), enabling early-leak detection and thus reducing the risk of pipe break. The system reports pipe flow measurement data with pressure and acoustic measurement, combines this information to GIS data and sends automatic alerts to identify the location of possible leaks, thus allowing the prioritization of repair work.

Sensors can also be incorporated to optimize the water used in irrigation, measuring parameters such as air temperature, air humidity, soil temperature, soil moisture, leaf wetness, atmospheric pressure, solar radiation, trunk/stem/fruit diameter, wind speed/direction, and rainfall. Urban applications range from park irrigation to commercial irrigation systems, enabling better management and a more accurate allocation of water resources between sectors.

Sensors can also be incorporated to assess the water quality of surface water, as well as treated water sewage within cities. Currently, many monitoring tasks (e.g. sampling the chemical condition of water, sediments, or fish tissue for quality assessments) are still conducted manually, requiring human resources for sampling and further lab analysis. In addition to the cost of maintaining such monitoring programs, there are difficulties associated with the provision of effective warnings due to the lag time between data retrieval and data assessment.

To overcome these problems, more and more water quality monitoring programs are striving to deliver on-line (and sometimes real-time) water quality monitoring. Smart sensor networks for in situ monitoring are being utilized to improve water resource and wastewater management. Such sensors are the core of these systems, which perform the online measurement of the fundamental parameters of water quality including pH, conductivity, dissolved oxygen, turbidity, ammonia, phosphorus, nitrate, chemical oxygen demand (COD) and metal ions, etc.

Novel sensing technologies (e.g. micro-electro-mechanical-system technology, electrochemical technology, and spectrophotometric technology) are applied to these sensors to achieve satisfactory measurement results with lower power consumption and lower cost requirements. These sensors are connected through smart sensor interfaces like IEEE 1451 standard, with reliable wired and/or wireless network technologies (e.g. Wi-Fi, ZigBee, International Society of Automation (ISA100), mobile network). Thus, the system is easily expandable to cover the broader water sector. Intelligence is integrated through the use of automatic control technologies and computer technologies, in order to ensure sample pre-treatment, sensor measurement, data collection, processing and analysis, and system communications.

Major tasks for smart sensor networks in water quality monitoring include the following:

- Identify and characterize changes in existing or emerging trends in surface water quality over time.
- Gather information to design or assess specific pollution prevention or remediation programmes, or to provide information in a timely manner to allow quick response to emergencies, such as spills and sewage leakages.
- Determine whether programme goals – such as compliance with pollution regulations or implementation of effective pollution control actions – are being met.

Integrating smart pipes and sensors within the urban system enables key functions such as the detection of events based on the monitoring of flow rate, pipe pressure, stagnant points, slow-flow sections, pipe leakage, backflow, and water quality to be monitored, which constitute data needed to optimize the operation of current networks.

#### **b. Smart metering**

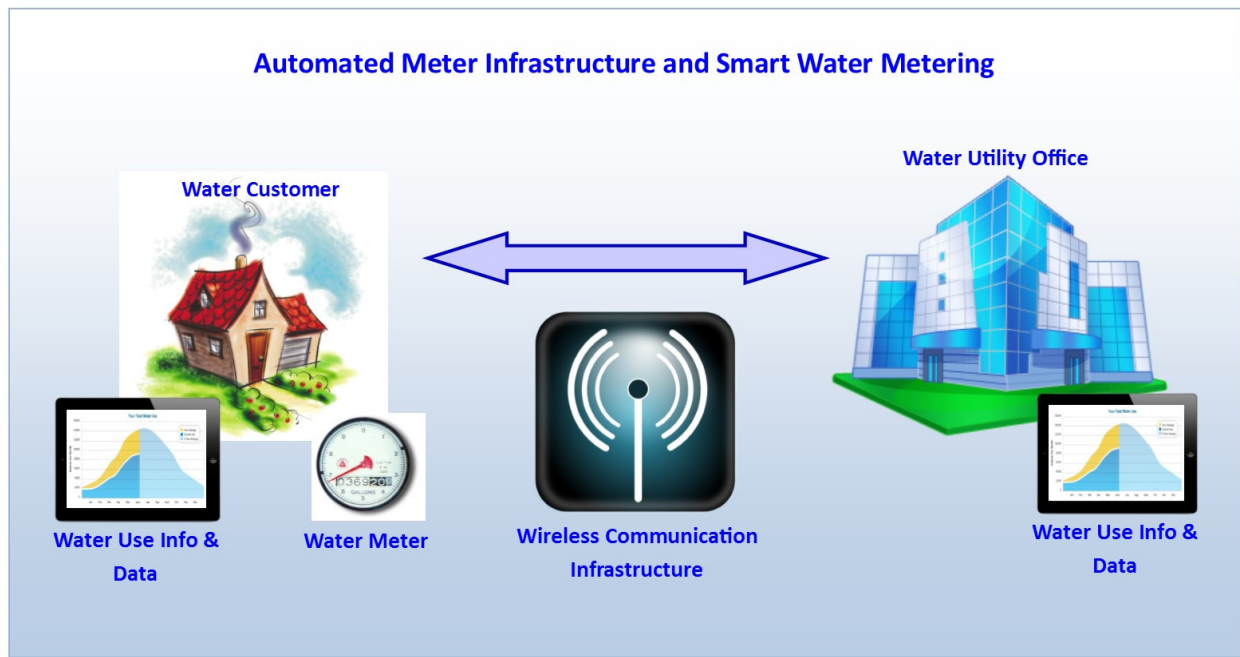
Smart meters are electronic devices with advanced metering infrastructure (AMI) that supports on-line measuring of electric, heat, gas, and water consumption. These devices are rapidly evolving in response to market forces and governmental regulations. In the case of water consumption, smart meters typically consist of an embedded controller that interfaces with a metering sensor, a wireless transmitter, as well as communication extension and a 10-to-15-years-lifetime battery, as there is no mains power supply available for water meters. The meters are connected to a network of data logger which allows for the continuous monitoring of water consumption of a city, a building, a business or a home. The innovation of smart meters enables a two-way communication when required between the meter and a central system by transmitting data, which can be done through different channels (e.g. radiocommunication, power line, Internet, telephone). As smart water meters are battery powered, the main communication channel is based on radiocommunication between the smart meter and the network of RTUs, then on GSM/GPRS (or equivalent) up to the central system.

Smart meters typically collect consumption data, and then transmit this data to a gateway that interfaces with the local area network (LAN), home area network (HAN) and wide area network (WAN). The LAN consists of the metrology or measurement function of the meter, while the HAN is connected to the customers' network. Due to the display functions of HAN, it easily allows accessibility to consumption data through a user-friendly interface, allowing customers to compare and track their water consumption. As HAN functions are energy consuming those can be replaced by a web access to Home Data and collected via the LAN and the WAN. WAN is managed by the utilities and allows them to track, monitor and bill consumption.

The deployment of smart meters within an urban infrastructure enables remote accessibility of consumption data, which improves meter reading and billing, detection of leaks, illegal connections

and tamper alerts, and can also enhance the identification of peak demand mainly for energy. Customer and provider relationships are improved through increased communication, utilities can improve their tariffs policies and consumers can be equipped with options like on-line alarms in case of leak or suspicious consumption, or the possibility to change payment methods (e.g. prepaid or postpaid).

Smart metering also allows water utilities to provide clear water consumption information which can help customers to track and control their water usage, and identify immediate savings on their bills, thus enabling better distribution network and consumption planning due to its real-time monitoring capabilities. Figure 9 illustrates an example of AMI infrastructure and SWM capabilities.



Source: Alliance for Water Efficiency (2014).<sup>27</sup>

**Figure 9 – Smart meter technologies**

### c. Communication modems

Communication solutions include Bluetooth, Wireless M-Bus communication, global system for mobile communications/general packet radio service (GSM/GPRS), and Ethernet, among others. These solutions allow remote reading of sensors and meters by the direct transfer of real-time or time-stamped data to the central management system of the utility or water authority. The data is then made available online for customer information system (CIS), geographic information systems (GIS), cloud computing or supervision and data management tools, supporting improved decision-making within the system. Such communication devices incorporated with smart meters/sensors can also provide alerts to authorities (e.g. reverse flow, leak alert, fraud alarm, and battery levels, water quality alarms). Most of these types of communication solutions ensure spatial redundancy and enable a wide range of coverage between distant buildings, housing estates, and other districts. In the traditional collection systems, considerable amounts of time would have been wasted finding and measuring points, especially in remote locations.

### d. Geographic information systems (GIS)

Geographic information systems (GISs) allow to capture, manage, analyse and display geographical information for underground assets description and decision-making. GIS has a wide range of

applications in various sectors (e.g. natural resources, utilities, transportation, public safety and defence). Their integration can improve data management especially of large volume projects, since they provide high quality results' display (particularly in hydraulic simulation modelling), thus enabling additional analysis to inform decision-making.

GIS allows visualization and analysis of water resources and human activity data by linking geographic information with descriptive information. This is highly valuable to urban water management in assessing water quality and day-to-day operations on a local and regional scale. Other issues such as flooding can also be mitigated by the use of geographical information, by helping to identify critical areas that are at risk. This is necessary in the development of hazard maps, as well as in the planning of emergency responses. GIS utilization offers more robust analysis, increased efficiency and reduced costs.

By integrating information from resource satellites, GIS can cover large river basins which are occupied by some cities. Combined with local rainfall patterns, meteorological and hydrological data, as well as drainage systems, geographical information and interfaces improves urban storm water management by strengthening drainage management and enhancing rainwater reuse, thus helping to reduce the prevalence of urban flooding.

#### e. Cloud computing

Cloud computing uses an external computing power ability which is outside the boundary of a user's own infrastructure, to run programs or applications. Cloud environments typically enable the following functionalities: monitor and manage computing without human involvement, broad network access to allow computing services to be delivered, access over several networks and heterogeneous devices, technologic ability to scale up or down computational resources swiftly and as needed, ability to share across multiple applications, as well as to track applications/tenants for billing purposes.

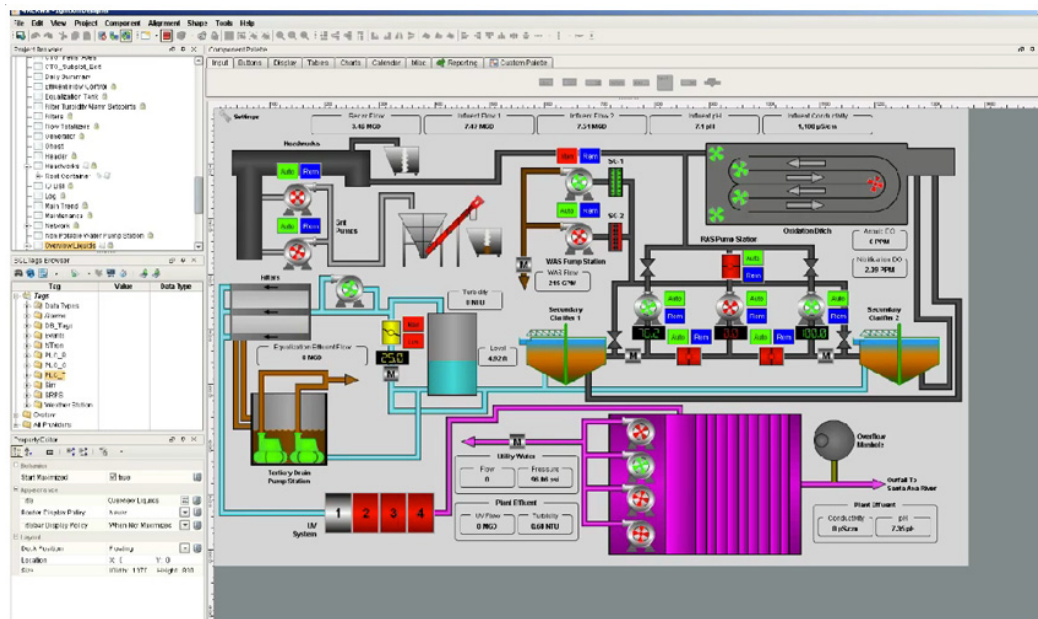


Cloud systems in urban settings also allow high efficiency and high utilization of pooled resources for a better balance of workload and computation through multiple applications, providing urban water managers with a wide range of possibilities in computer modelling and data storage. Urban flood management is another area where cloud computing is increasingly use.<sup>28</sup>

Beyond their technological interest, various issues like data privacy, security and ownership have to be clearly validated by the cities prior to any massive deployment of Cloud computing solutions.

## f. Supervisory control and data acquisition (SCADA)

When incorporated into water management systems, supervisory control and data acquisition (SCADA) are computer-controlled systems that contain a large variety of communication systems, allowing to monitor and control water treatment and distribution, as well as wastewater collection and treatment. The system allows for supervision through data acquisition and management, and has the ability to process and send commands within the system. The communication system may involve radio, direct wired connections or telemetry. An example of the structure of SCADA software is presented in Figure 10.



Source: Automation World, 2014.<sup>29</sup>

**Figure 10 – Example of SCADA software, Western Municipal Water District (WMWD), California**

Utilities have been using SCADA systems managing real-time alarms and efficiently operate plants and networks.

In some case, SCADA systems are going beyond their native functionalities by proposition optional modules on modelling or optimization. Even if these functions are described in the next chapter, a few examples of higher-level applications can be listed; such as determining times of peak water use, identifying potential system leaks, and setting billing rates, among others.

Globally speaking SCADA systems have contributed to reduce the operating costs of utilities, and have improved water distribution to households, businesses and industry. The monitoring and control functionalities of SCADA systems can help utilities to protect their infrastructure and prevent severe degradation. The implementation of SCADA has been associated to 30% savings on energy used to manage water systems, 20% reduction on water loss and 20% reduction in disruption<sup>30</sup>. Usage of SCADA as part of urban systems can also enhance disaster preparedness through storm water management, as well as support the remote operation and monitoring of major dams and weirs.

## g. Models, optimization tools and decision support

Model-based water management has evolved over the years to improve the quality, quantity and operations costs of the global water supply through comprehensive modelling applications. These modelling software incorporate, to some extent, processes observed in the real world (e.g. through



equations, algorithms and scenarios) and contain various data reporting and visualization tools for interpreting results from water distribution piping systems, water quality monitoring data, and wastewater management systems, among other relevant information for decision support. Multiple models have been used by urban water managers such as Mike Urban, Aquacycle, AISUWRS and UGROW, among others.



Optimization tools aim to find the best technical, environmental and financial solutions from models. Therefore, "optimization tools and principles have made it possible to develop prescriptive models for optimal management of large scale water resources systems, incorporating ubiquitous uncertainties in the prediction of natural processes and the economic impacts" (Datta and Harikrishna, 2004)<sup>31</sup>. The use of optimization tools can play an important role in effective decision-making towards the planning, design and operation of water resource systems.

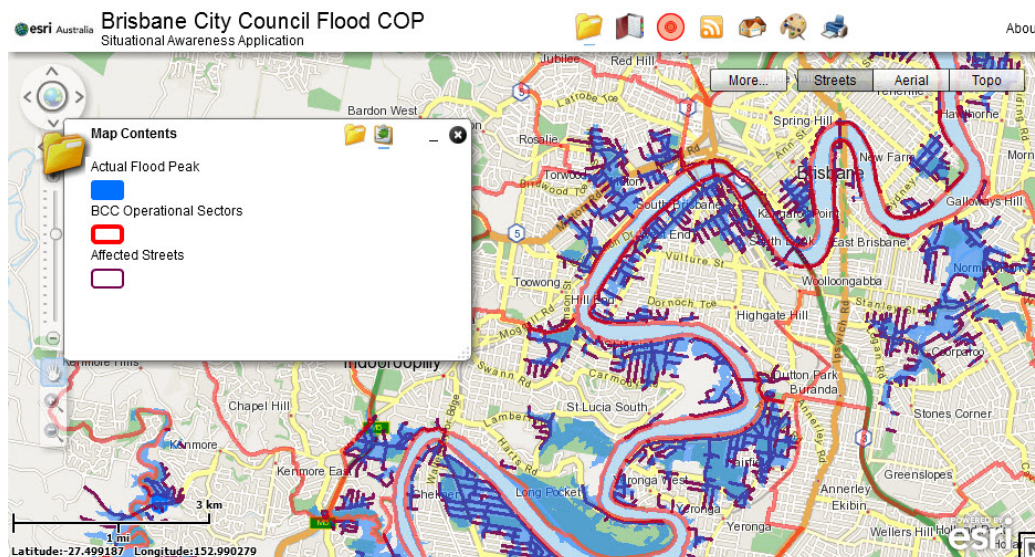
Models, optimization tools and decision support tools for network management of urban water resources contribute to calculate and forecast consumption, reduce costs through the optimization of operations, plan and evaluate strategies, and also to conduct vulnerability studies to inform strategy design.

#### **h. Web-based communication and information system tools**

Information and knowledge management are increasingly recognized as an important features for the effectiveness of the water sector<sup>32</sup>. A key problem faced within the sector is the existence of a large body of complex, unstructured and fragmented data. Web-based interfaces and online platforms provide a solution to enable the effective management, display, and retrieval of relevant information required by water managers/operators, urban planners, governments and the public.

Figure 11 provides an example of the role played by web-based technologies in city-based flood maps.





Source: Brisbane City Council (2014).<sup>33</sup>

**Figure 11 – Example of web-based technologies and city flooding:  
The Brisbane City web-based flood map**

Web-based servers offer access to integrated information from heterogeneous data sources, as well as innovative tools for the analysis and assessment of issues such as climate change, water scarcity, human health, sanitation and urbanization, all key factors to consider as part of urban water management. The integration of such web-based communication tools using open communication standards allows a range of stakeholders to connect to the system, and use available resources.

At the same time, communication and information systems can enable both the general public and administrators to access relevant information, fostering transparency and visibility of current water related activities by the specialized users (e.g. water managers, municipalities, governments), facilitating trust-building and public/stakeholder involvement. An intuitive and user-friendly interface fosters data accessibility and dissemination, especially for the public.

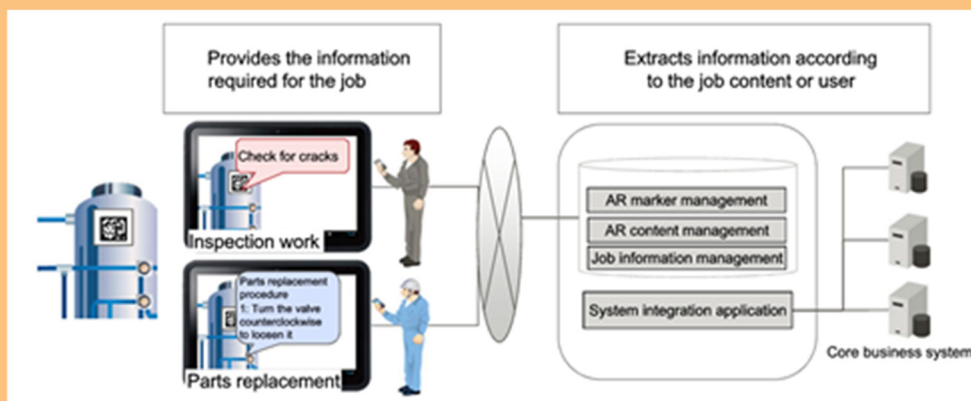
Web-based communication and information system tools are used by governments and municipalities to deliver relevant water information to the public, as well as to provide early warnings (e.g. flood alerts). They also allow urban water managers to access relevant information such as rainfall data, storage and distribution, among others, thus helping to inform decision-making processes at multiple levels.

Data and systems security is a key point that has to be carefully addressed prior to any implementation of web-based technologies for Cities and Utilities, and in compliance with existing corporate standards and policies.

Another example of a related ICT tool for water infrastructure management is provided in Box 1.

### Box 1 – Augmented Reality based Water Infrastructure Management

Augmented Reality (AR) is a technology that extends and enhances human awareness, by superimposing digital information acquired using ICT in real world information that humans obtain via sight and hearing. Highly recognizable augmented reality markers are required for water infrastructure maintenance. Mobile devices can allow to recognizing them easily, despite conditions such as darkness, outdoor environments, dusty areas, or places that are difficult to access. This technology is applied in water infrastructure management and maintenance practices to obtain optimal information for an operation on site, linking real images by simply pointing the camera of a smart device towards an augmented reality marker. The appropriate information can be adjusted to specific needs and job descriptions. For example, an inspection worker should see checkpoints, while a worker conducting repairs should see maintenance procedures. Augmented reality technology enables more efficient and higher quality of maintenance operations by prompt access to necessary information including procedures and veterans' know-how via images and recorded sounds which allows a worker intuitive understanding of what he or she should do. Indeed, daily communication for water infrastructure management and maintenance practice was typically implemented by oral or on whiteboard and papers. This makes it difficult to ensure accurate information and know-how sharing among workers and becomes a reason to decrease quality of maintenance.



## 5 SWM integration: Strengthening urban water management

Various smart water management initiatives are driving innovation and creating solutions at different scales worldwide. Within urban contexts, emerging initiatives involve smart grid integration, web-based communication, urban water management tools, models and systems, among others. The examples presented in this section are meant to provide a snapshot of some of the initiatives related to urban water management, urban wastewater management, and urban flood management issues, all of which are of vital importance to the effective functioning of SSC.

### 5.1 Intelligent solutions in urban water management



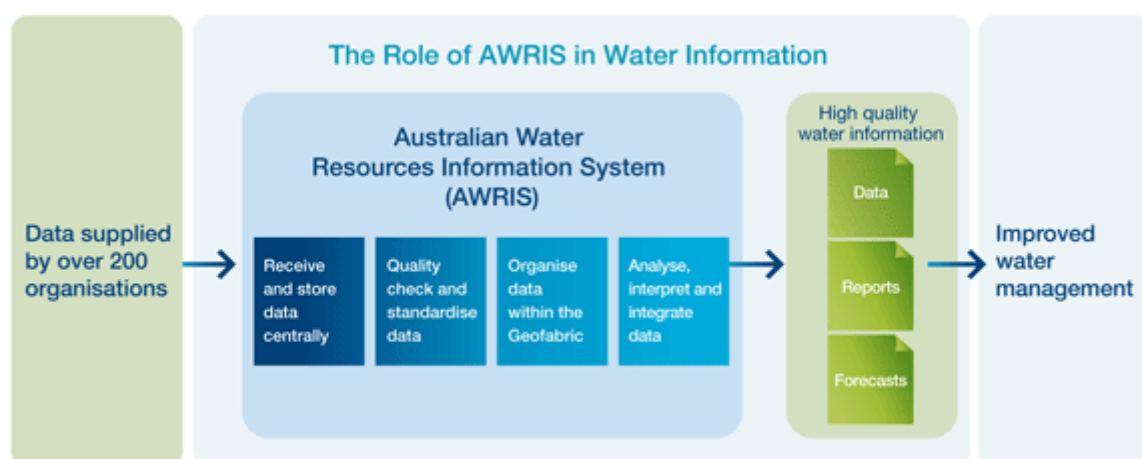
#### Aquadapt

Aquadapt software integrates with existing management systems to help utilities make operating decisions that reduce energy consumption (i.e. water pumps) typically one of their highest costs after personnel. Aquadapt also contributes to improve water quality and greater consistency of operations. This software is used in water utilities in North America, the United Kingdom, Korea and Australia.



#### Australian Water Resources Information System

The Australian Bureau of Metrology is currently building the Australian Water Resources Information System (AWRIS) as a tool to manage and display data from more than 200 organizations across the nation since it became responsible for delivering water information for Australia. The information system is intended to be a secure repository for water data and a means to deliver high quality water information to the public. Through data standardization, integration and organization, AWRIS will lead to improvements in the quality and efficiency of Australia's water management and policy decision-making. The system is illustrated in Figure 12.



Source: Australian Government, Bureau of Meteorology, (2014).<sup>34</sup>

**Figure 12 – The AWRIS system**

Further information about this solution is available at:  
<http://www.bom.gov.au/water/about/wip/awris.shtml>



### AQUADVANCED an innovative IT solution

AQUADVANCED helps water operators to reduce operational costs, control water quality, and save water and energy. Its intuitive and modular interface gives operators a comprehensive view of the water network performance in real time, and enables them to efficiently manage their distribution networks. AQUADVANCED makes complex data actionable by gathering and analysing all the data coming from GIS, SCADA, sensors, data historian, workforce management, customer relation management in one single platform and turning it into a simple decision-making tool. More precisely, AQUADVANCED easily manages sectors by monitoring flows, pressure, water quality, and energy. It offers advanced event management (leaks detection, pressure level drops) in order to identify abnormal events and their causes, locate them accurately and monitor their resolution. The software analyses hydraulic behaviour in order to anticipate failure risks and simulate the impact of interventions. It also continuously monitors water quality throughout the water distribution network, as well as energy performance and provides optimal energy operating strategies.



Figure 13 – Screenshots of AQUADVANCED interfaces



### EU UrbanWater project

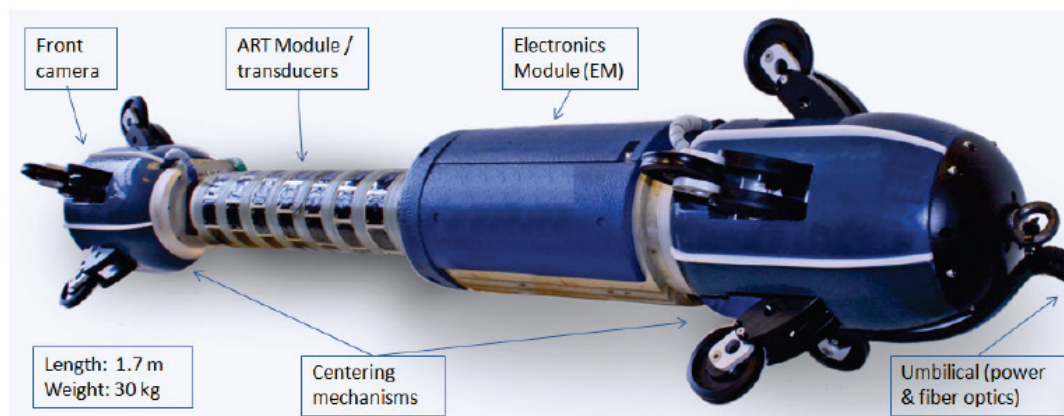
UrbanWater is a collaborative ICT project co-funded under the 7th Framework Programme of the European Commission. The project is expected to be completed in 2015. It seeks to create an intelligent web-based urban water management system for effective urban water management. The platform will incorporate advanced metering solutions and real-time consumption data to equip water utilities with the information necessary for proper decision-making.

By integrating water availability estimations based on weather prediction and surface water reserves data, demand estimations based on household consumption data and consumption patterns and models, the water distribution network data, as well as automatic billing capabilities including adaptive pricing and customer engagement tools and using secure and cloud-based data management, both utilities and customers alike will be able to obtain the right information to effect change in consumption patterns in urban areas.

Further information about this initiative is available at: <http://urbanwater-ict.eu/the-solution-2/>

### Improvements in pipe scanning

Breivoll Inspection Technologies (BIT) is a Norwegian Small-Medium Enterprise (SME) and provider of condition water pipe assessment technology. BIT has developed pipe scanners and a pipeline analysis and reporting system (PARS) for the assessment of urban pipe systems. The pipe scanners are based on the acoustic resonance technology (ART) (Figure 14), and equipped with cameras to assess the health of urban pipes. The PipeScanner analysis and reporting system (PARS) imports raw data from ART of the PipeScanner and performs the processing of data at the headquarters, through advanced algorithms and data filtering in a high-performance data centre. Information extensions are also available to export data to GIS databases.



Source: Brenna *et al.* (2013).<sup>35</sup>

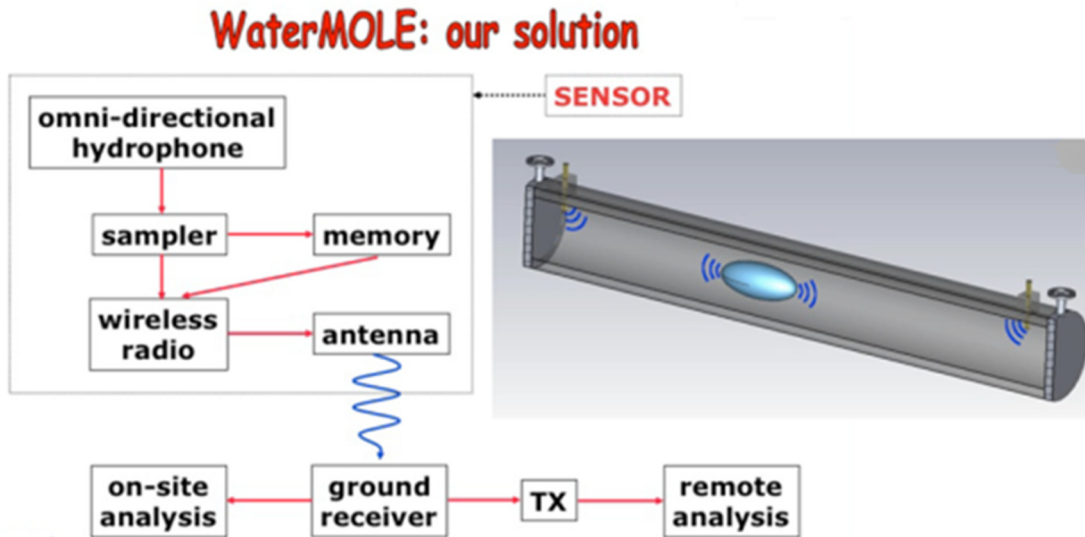
**Figure 14 – The BIT PipeScanner, 2<sup>nd</sup> generation**

Further improvements in this technology could enable cities to access reliable data on internal and external water pipe conditions, as well as data for modelling purposes. This technology can also facilitate linkages with other intelligent infrastructures, thus contributing to reducing costs and improving management. More information on these technologies is available at: <http://en.breivoll.no/>

### Wireless mobile sensors in underground pipes

iXLEM Labs in collaboration with Qatar University, Qatar National Research Fund, Acquadotto del Monferrato, Smat and Karamaa have created a solution to monitor and manage issues related to urban water distribution systems (Figure 15). Their solution comes in the form of "Watermole" which is a wireless mobile sensor that can be placed in pipes for monitoring. When the sensor intercepts a ground station, its position is identified and the acquired spectra are correlated to leakage positions (iXLEM 2011). For more information visit: [http://www.ixem.polito.it/projects/qnrf\\_2009/index\\_e.htm](http://www.ixem.polito.it/projects/qnrf_2009/index_e.htm)





Source: Trincherro (2010).<sup>36</sup>

Figure 15 – WaterMOLE, 2<sup>nd</sup> generation

## 5.2 Remote monitoring solutions to urban wastewater management

### SolidAT and Holon Municipality, Israel

Located in the centre of Israel, Holon municipality's old sewage system was plagued with problems such as frequent blockages and overflows. By installing several of Solid Applied Technologies' (SolidAT) SmartScan 50 non-contact gauging devices equipped with sensors, the municipality was able to better control and manage its sewer systems. Additional improvements were achieved due to the high resistance of the devices to the methane environment, and to the municipality's ability to receive reliable information and monitor its sewer system using a web platform, and sending alerts via short message service (SMS) messages when the level reaches low/high limits.



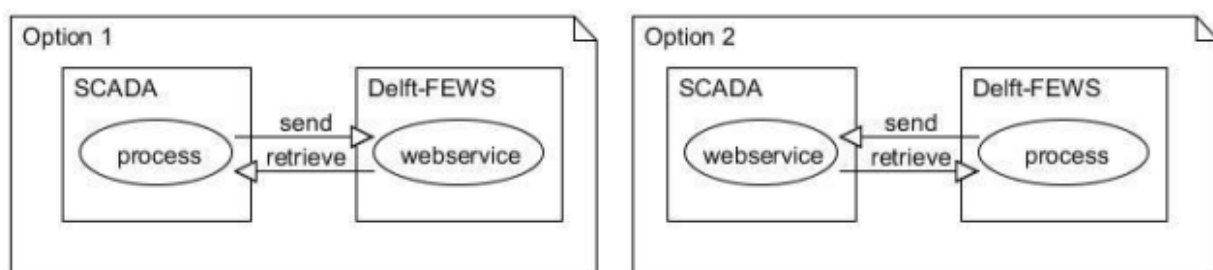
SolidAT offers a variety of level sensors and remote monitoring solutions for sewer level monitoring and water level monitoring. Further information is available at: <http://solidat.com/>

### Delft-FEWS and Hollandse Delta Regional Water Authority, Netherlands (pilot project)

In the Netherlands, extensive sewer networks are linked with SCADA. However, systems are not linked to Wastewater Treatment Plants (WWTPs) nor are they linked together, as each municipality is responsible for maintenance and operation within its boundaries. The system is vulnerable to



storm events which sometime results in the contamination of surface waters. The pilot project was supported by grants from Agentschap NL, and investigated the possibility of optimizing the sewage flow through the entire system through the use of an automated centralized control of the system: by linking the SCADA systems of the regional water authority Hollandse Delta, and the WWTPs of five municipalities (Binnenmaas, Cromstrijen, Korendijk, Oud-Beijerland and Strijen) and using the dynamic modelling component of Delft-FEWS. Delft-FEWS is a real-time operation water management and forecasting software. Data was collected from each SCADA system and fed to Delft-FEWS, where a real time control (RTC) plug-in calculates the optimal pump settings. The settings calculated from Delft-FEWS were then sent back to the SCADA systems to control the sewer pumps (Figure 16)<sup>37</sup>. The project demonstrated how SCADA systems can be easily converted to centrally controlled operating systems. It is still working as an operational system, with plans to expand its functionality to other municipalities.



Source: Rooij and van Heeringen, (2012).<sup>38</sup>

**Figure 16 – Options investigated within Delft-FEWS real-time control of sewer system pilot project**

### 5.3 Technologies for urban flood management



During rain and storm events technical services of cities have to ensure the safety of people and goods, protect the natural environment, comply with discharge regulations, and more generally make the best use of wastewater and stormwater assets capacities. Operators have to make use of all the capacities of the system: retention capacities of the network, optimal filling and water draining of storage basins, and maximal loading of the wastewater treatment plants. INFLUX is a predictive and dynamic management system that gives the operator an overall view of the operation of the entire sewage system based on validated metrological data, calculates trends and system behaviour for the coming 24 hours in dry weather and 6 hours in wet weather, and proposes the operator an optimal management strategy applied manually or automatically. The aim of the strategy is to store as much volume as possible in the water retention assets and the system itself, to increase the volume of wastewater to be treated in order to reduce outflows into the natural environments whilst limiting floods risks. This tools was installed in cities such as Bordeaux (CUB) or Paris (SIAAP) in France.

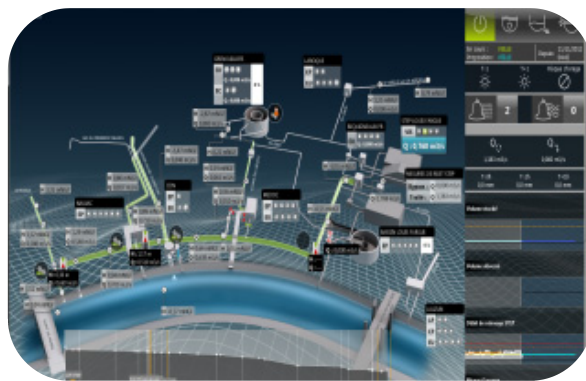


Figure 17 – Screenshot of the INFUX interface



The RainGain project is a transnational project aimed at improving urban flood prediction. Since radars have the advantage of being light, manageable, and more affordable to local water authorities, they were chosen as the medium of data collection. By collecting detailed rainfall data at an urban scale from weather radars, the project seeks to provide reliable information to city water managers to develop reliable urban water strategies, thus contributing to make cities more resilient to local rainfall-induced floods.



Source: DLFT Urban Water (2014).

Figure 18 – RainGain project location

The project investigates four different types of radar techniques in four pilot European cities (i.e. Leuven, London, Paris and Rotterdam) (Figure 18). The project involves the installation of new polarimetric X-band radars in Rotterdam and Paris, enhancing previously acquired X-band radar, as well as the acquisition of four additional rain gauges in Leuven, and upgraded C-band radar for testing and implementation of super resolution protocol in Greater London. The following areas will be investigated:

- Early warning systems based on fine-scale flood prediction, based on London's project experience.
- Real-time operational strategies of storage basins and pumping stations to maximize rainwater storage, based on the project's experience in Paris and Leuven's.
- Upgrading the capacity of urban water systems, based on Rotterdam's experience.

It is envisioned that, through the implementation of this initiative, city water managers will be better equipped to manage urban flooding by being able to make flood forecasts at the street level, in real time. For more information please visit: <http://www.raingain.eu/en/four-cities-gain-rain>

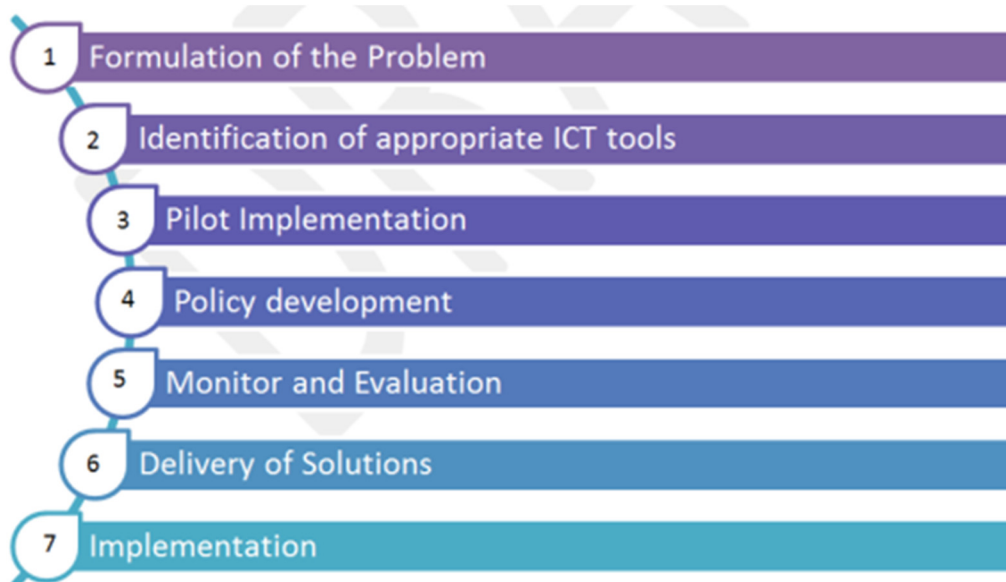
## 6 Action steps: SWM implementation

The series of key steps presented in this section aims at facilitating the design of strategies for the implementation of SWM systems. They encompass the methods and approaches that need to be considered as part of SWM's implementation, including concrete actions to realize each stage.

Following these action steps can contribute to the following:

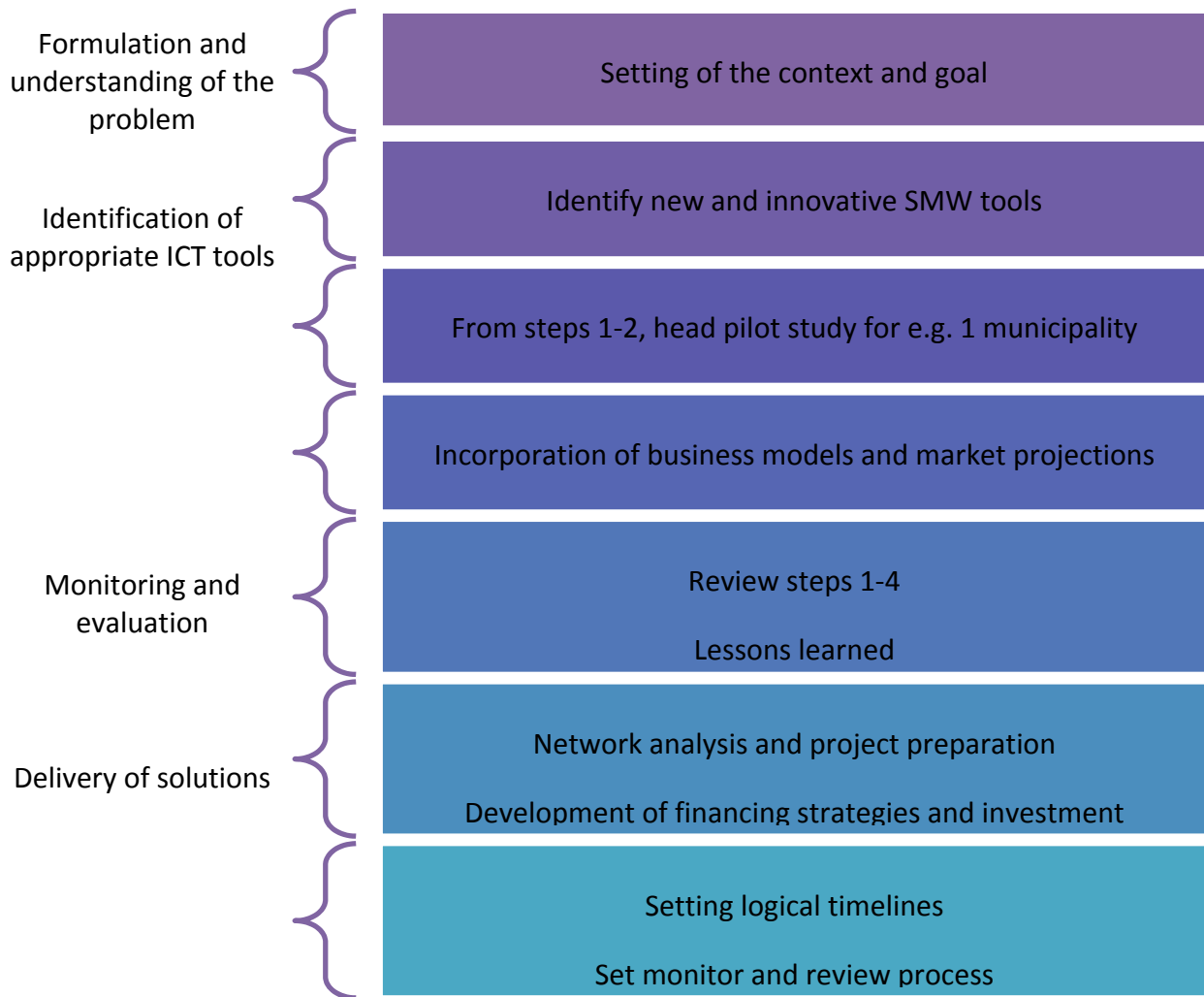
- Target problems faced by urban water environment.
- Enhance efficiency and higher quality of services provided by SWM tools.
- Ensure proper robust policy development.
- Guarantee transparency.
- Promote further technological innovation.

The effective design and implementation of SWM involves the seven key steps presented in Figure 19.



**Figure 19 – Steps towards the implementation of SWM**

Based on these main areas, Figure 20 summarizes the key actions that need to be conducted in order to realize each of them, and ultimately, implement SMW solutions.



**Figure 20 – Key actions involved in the implementation of SWM**

The actions conducted as part of these different stages are closely related, and in many cases, complement each other.

Having identified some of the key actions needed to successfully design and implement SWM, the following section explores the opportunities linked to these systems as part of water management systems.

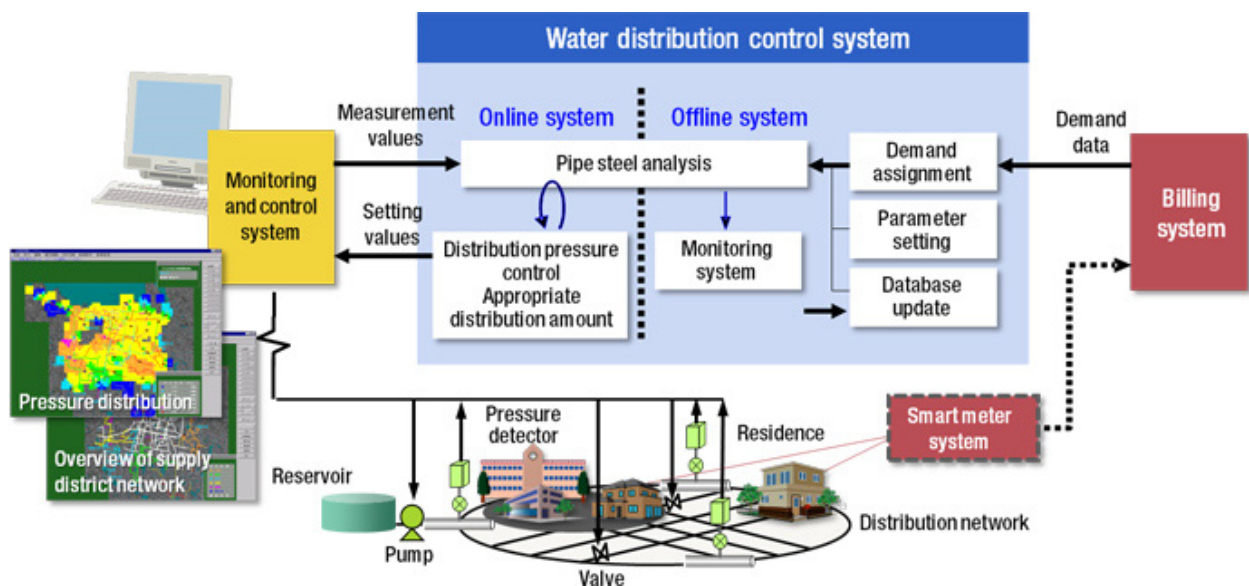
## 7 SWM opportunities

The integration of smart water management technologies through realistic, measureable timelines and adequate implementation processes can deliver immediate visible and measureable results in urban water distribution and wastewater management. While challenges still exist, the analysis presented in this Technical Report suggests that the benefits are clear and significant. Through co-ordinated actions, holistic management, stakeholder involvement, adequate investment, and appropriate technology, SWM can improve both the reliance and sustainability of the water systems and networks. By protecting the safety and reliability of water supplies, increasing the resilience of water infrastructure, reducing flooding and overloads of wastewater systems, decreasing energy consumption, lowering operational costs while increasing customer choice and control, these systems can enable a sustainable water environment for cities to grow and thrive in.

Recent advances in technology and interconnectedness, once appropriately harnessed, can foster the conditions needed to promote sustainable water resource management in the face of rapid urbanization, water scarcity and climate change. This will enable cities to conduct the following tasks:

- Collect easily real-time data and measurements through sensor networks and low-cost innovative communications and protocols.
- Make better informed decisions through the use of advanced analytics which translate the raw data into actionable intelligence.
- Improve the efficiency, performance and optimization of infrastructure through real-time management systems.

The traditional independent system approach to urban water supply, wastewater disposal and storm water management will no longer be able to endure the increasing pressures faced by the water sector. However, the co-ordination of multiple sectors through SWM networks can contribute to ensure the sustainability of urban water management system. Through connectivity, SWM networks can allow water, wastewater and storm water information to be extracted and integrated into other data sources such as climate analysis and weather intelligence, thus facilitating a holistic management approach to overcome the pressures and challenges faced by the system. Figure 21 illustrates some of the SWM tools that play a role in water distribution control systems.



Source: Hitachi (2014).<sup>39</sup>

**Figure 21 – Smart water management tools**

SWM also generates economic, social, and environmental benefits through water resource sustainability, which, in turn, contributes to the comfort, security and well-being of urban residents. Some of the benefits associated to water and wastewater management include:

- **Economic savings:** SWM tools can greatly reduce non-revenue water by identifying leaks and illegal connection, regaining revenue necessary to maintain the infrastructure. SWM enables sustainable water use, thereby reducing the amount of water abstracted, treated and distributed which reduces operational costs.

- **Improved services:** Smart metering can improve the relationship between the water utilities and the customers by providing more transparent water consumption information. Improved monitoring and operations prevents supply interruptions and disruptions within the water distribution network, for example, in the event of sewerage and storm water overflows. Better management relieves pressure on water resources that may be scarce during periods of drought.
- **Improved wastewater management:** These benefits are associated to improvements in the performance and economic efficiency of the wastewater treatment, as well as enhanced monitoring that helps prevent infrastructure overload.
- **More efficient treatment:** Improved water quality monitoring throughout the systems utilizing sensors creates the possibility of source control of resource pollutants and the use of natural systems, thus reducing the potential treatment required for water supply systems, or the separation of specific pollutants in wastewater.
- **Environmental protection and enhancement:** Reduced demand and improved environmental monitoring helps to maintain and restore ecosystems that rely on a healthy aquatic environment.
- **Reduced carbon emissions:** Improved management results in less energy consumed for the abstraction, treatment and distribution process of water resources, thus helping to reduce a city's carbon footprint.
- **Flood control and storm water management:** Improved weather awareness and prediction through weather intelligence allows cities to plan more effectively their flood prevention strategies, as well as to manage urban drainage systems and storm waters accordingly.
- **Greater resilience:** Reliable data reduces inaccurate forecasts and predictions, as well as the uncertainty surrounding future demand and supply availability, thus improving decision-making for water investments and strategies. Improved operational control and monitoring can also help to prioritize infrastructure maintenance. At the same time, improved decision-making strengthens the capacity of centralized sewers and treatment facilities to cope with the pressures of urbanization.

## 8 Gaps to be addressed

---

It is imperative that urban water managers adopt appropriate water intelligence within their various management systems, and develop the capacity needed to realize the full potential of ICT tools in this field. Numerous experiences suggest that smart water management tools can be easily integrated. However, the current approach and lack of standardization within this sector may foster future problems of interoperability and reliability of SWM tools, possibly preventing future integration of system solutions. Added to this, improper policy development spearheads vendor and/or technology deadlocks.

These challenges could hinder the proper implementation of SWM tools in cities around the world. Some of the challenges mentioned throughout this analysis are discussed in further depth in the ITU and UNESCO's publication "Partnering for Solutions"<sup>40</sup>, including the lack of technological standardization, proper ICT governance, policies, incentives/funding, business case and models (customer propositions/pricing/availability, value for water utility, etc.), co-operation and collaboration between stakeholders (water utilities, urban planners, policy makers, governments, municipalities, academia, ICT companies, public, etc.), focus placed on privacy/security/encryption,



awareness and know-how, and limitations within the technology architecture (components/systems integration/communication/local vs global).

For the purposes of this Technical Report, the focus is placed on challenges related to standardization and policy perspectives. Other challenges will be addressed in future studies.

### **Lessons learned: Standardization and policy perspectives**

Innovations in the ICT field are the result of a highly complex and continuously changing environment. To ensure the efficiency and the effectiveness of ICT products, tools and systems, standardization is essential. Standards contain the technical specification or other precise criteria designed to be used consistently as a rule, guideline or definition. Their adoption ensures a clear reference in terms of technical specifications, quality, performance and reliability<sup>41</sup>. The objective of standard development is to ensure that products and services are suitable for their purpose, enabling comparability and compatibility through a form of best practice summary, which evolved from the experience and expertise of all interested parties.

With regards to smart water management tools in cities, there are some trade-offs. Since this market is in its initial stages, standardization within this sector can either spur creativity and maximize the added value of technology for cities, or hinder further development within this sector. However, it must be stressed that timing is essential as it bridges research and innovations. Sensible standards introduced at the right moment can produce universal benefits<sup>42</sup>. In this regard, adequate standardization can serve as a risk management and technology roadmap guideline, enabling the strategic implementation of smart water management plans and projects.

Since smart water management solutions depend on ICTs, interoperability is also crucial. If the solutions are not interoperable, their effectiveness is highly restricted, especially in terms of enterprise networking. Interoperability of ICT products and their components refers to its ability to work with other systems or products without special effort on the part of the user. Standardization is an essential component for ensuring that ICT products, tools, and systems are produced and implemented in an efficient, equitable, and ecologically sustainable manner.

Reinstating its role as a standardization organization, ITU has developed key ICT standards in ubiquitous sensor networks (USNs), Internet of things (IoT), and machine-to-machine (M2M), in order to ensure that there is compatibility, interoperability, and certain levels of quality maintained, therefore contributing to the reduction of risks. However, the current pace of technological development demands further efforts, and pushes standardization and research to advance in parallel.

Recognizing the need for further standard development in this area, the ITU FG-SWM will be conducting a crucial gap analysis on smart water management tools, products and solutions. The analysis will provide the necessary guidance to produce sensible standards within this field, thereby steering the market in the right direction, and helping to make sure that the right tools can lead to the right solutions in cities.

As standardization provides a measure by which to judge the quality of an ICT product or tool, it is a key instrument for securing policy initiatives. In turn, proper policies will support the effective implementation of smart water management solutions in both developed and developing countries.

Though policies have been developed and deployed to target smart water initiatives, they have been met with mixed results, and in most cases, the focus has been placed on smart water metering alone. In some cases, these policies have fostered development and more research and innovation

with regard to the smart water technology market. In other instances, they have contributed to stifle the development of this market.

Countries such as Canada, Israel and Singapore have been implementing policies at both the national and state levels on smart water systems, supporting green innovation and intelligent water technologies, which have led to the emergence of new smart water companies<sup>43</sup>. However, these policies have not specifically targeted smart water systems, but instead have been presented in the form of "Sustainability, Environment, and Water initiatives", "Water Technologies" and "Efficiency Initiatives"<sup>44</sup>.

The key issues, however, have remained. What types of policies are required to accompany the development and stimulate the diffusion of ICT for water management? When should these policies be implemented? In addition to these issues, the baseline methodologies that need to be established for determining the trade-offs and synergistic benefits for ICT innovations within water management frameworks at the national and regional levels, have been overlooked, or otherwise focused on narrow sector-driven mandates.

Since the current smart water market is fairly new and fragmented, policies will need to be adaptable, while at the same time reflecting the country's intention of deployment and the type of technologies considered. Unfortunately, due the young nature of the smart water market, there have only been limited incentives and initiatives that pursue a more integrated research approach across sectoral domains. Herein lies a problem. Since policy developers need to co-ordinate efforts and have access to clear informational resources (many of which can only be provided through research and careful examination of the water sector within a given country), inadequate and narrow-minded frameworks are often designed.

In brief, properly timed and flexible policies are essential for the adoption of smart water management initiatives in urban areas. Therefore, governments should support new, generic, flexible smart water management incentives, especially those that support full system integration. This ensures that policy makers are better equipped with the knowledge necessary to design effective smart water policies. Coherent cross-sector policies developed through a multi stakeholder approach will ensure the success and sustainability of these tools.

Consequently, a coherent strategy must be the starting point before implementation of any city-wide SWM initiative. This facilitates the development of innovative partnerships to harness and utilize the necessary information effectively, thereby creating guidelines, strategies and best practices properly tailored through protocols and standards.

Standardization and policy development must be appropriately co-ordinated and taken forward based on robust research, including a careful examination of the water and wastewater sector, as well as the broad engagement of key stakeholders (e.g. different governmental sectors, non-governmental organizations (NGOs), academia, and the private sector) within a given city.

## Conclusions

---

Although cities represent just 2% of the world's surface area, they hold more than half of the global population. Providing sustainable access to water will be among the greatest challenges in the coming half century. As the analysis presented in this Technical Report suggests, fast-paced urbanization places high competition on existing water resources, and is exacerbating pressures linked to rapid population growth and to the uncertainty posed by climate change impacts. Failing to meet the new challenges and demands associated to water resources could seriously undermine

the ability of cities to achieve urban development, and to meet socio-economic and environmental goals. Therefore, it is crucial that traditional approaches are upgraded to enable smarter solutions, which are more effective in mitigating these challenges and in reducing costs through the optimization of existing and emerging infrastructures.

Smart water management (SWM) can play a key role in the transformation of cities of developed and developing countries into smart and sustainable cities (SSC), if adequate policies, stern governance, and broad stakeholder involvement are integrated into its planning and implementation. Through real-time monitoring, efficient operation, improved decision-making, and enhanced performance and service delivery, SWM can ensure that a city's growth is not achieved at the expense of its water resources. Further advantages such as increased revenue in utilities, reduced operational costs and increased public involvement place SWM as a viable, smart sustainable solution to address urban water challenges.

As emerging experiences suggest, initiatives on smart water systems have been more effective when implemented as part of broader strategic approaches to water management (i.e. water policy development). Therefore, efforts in this field must be coordinated and synergies built across the various sectors and stakeholders involved in water management. At the same time, experiences have demonstrated that public-private partnerships can be effective in fostering innovation. Further efforts should be made to strengthen the linkages between the utilities, industries and universities, in order to develop new research on smart water management, emerging challenges and opportunities, as well as novel water enterprises.

Acknowledging that both technical and non-technological innovations play a role in the effective operation of smart water systems, it is important that ICT developments are accompanied by innovations in the business models of water utilities, as well as by innovations in terms of water usage at the end of the pipe, so as to maximize the contribution of ICTs in this field.

Appropriate policies and measures are key to support the development and deployment of smart water systems (e.g. water pricing, education and information, competition for non-domestic consumers). Likewise, as smart water solutions continue to emerge and their integration to deepen in urban environments, the importance of common standards for hardware and software will continue to rise. These standards are key to encourage the international deployment of innovative technologies, and thus continue progress in the smart water management field.

A successful implementation of SWM requires that further emphasis be placed on the development of guidelines, best practices, standards and policies that are tailored to specific urban needs and priorities. These will ensure integrity, compatibility and interoperability among protocols, and promote accountability and security within the smart urban water management framework.

Through the work of ITU's Focus Group on Smart Water Management (FG-SWM) and Smart Sustainable Cities (FG-SSC), as well as its continued efforts on ICTs and climate change adaptation, ITU is contributing to the development of new standards and recommendations that will foster the adoption of smarter solutions in the water sector around the globe.

## Footnotes

- <sup>1</sup> UNDESA (2014), *World Urbanization Prospects: The 2014 Revision, Highlights*, United Nations, Department of Economic and Social Affairs (UNDESA), Population Division. <http://esa.un.org/unpd/wup/Highlights/WUP2014-Highlights.pdf>
- <sup>2</sup> UNDESA (2012), *World Population Prospects: The 2011 Revision, Highlights*, United Nations Department of Economic and Social Affairs (UNDESA) Population Division. [http://esa.un.org/unup/pdf/WUP2011\\_Highlights.pdf](http://esa.un.org/unup/pdf/WUP2011_Highlights.pdf)
- <sup>3</sup> Howe, C. A., Butterworth, J., Smout, I.,K., Duffy, A.,M., and Vairavamoorthy, K. (2011), *Sustainable Water Management in the City of the Future: Findings from the SWITCH Project 2006-2011*, UNESCO-IHE, The Netherlands. <http://www.switchurbanwater.eu/outputs/pdfs/Switch - Final Report.pdf>
- <sup>4</sup> OECD (2013), *Policies to Support Smart Water Systems: Lessons from Countries Experience*, Working Party of Biodiversity, Water and Ecosystems, OECD Environment Policy Committee, 30-31 May 2012, Paris.
- <sup>5</sup> McIntosh, A. C. (2014), *Urban Water Supply and Sanitation in Southeast Asia: A Guide to Good Practice*, Asian Development Bank (ADB), [http://www.pseau.org/outils/ouvrages/adb\\_urban\\_water\\_supply\\_and\\_sanitation\\_in\\_southeast\\_asia\\_a\\_guide\\_to\\_good\\_practice\\_2014.pdf](http://www.pseau.org/outils/ouvrages/adb_urban_water_supply_and_sanitation_in_southeast_asia_a_guide_to_good_practice_2014.pdf)
- <sup>6</sup> EURAMET (2013), *Mega City Paper*, European Association of National Metrology Institutes (EURAMET), <http://www.emrponline.eu/call2013/docs/MegaCities.pdf> .
- <sup>7</sup> Engel, K., Jokiel, D., Kraljevic, A., Geiger, M., and Smith, K. (2011), *Big Cities, Big Water, Big Challenges: Water in an Urbanizing World*, WWF, [http://www.wwf.se/source.php/1390895/Big%20Cities\\_Big%20Water\\_Big%20Challenges\\_2011.pdf](http://www.wwf.se/source.php/1390895/Big%20Cities_Big%20Water_Big%20Challenges_2011.pdf)
- <sup>8</sup> Kötter, T. (2004), *Risks and Opportunities of Urbanization in Megacities*, International Federation of Surveyors, August.
- <sup>9</sup> Kraas, F., and Nitschke, U., (2008), *Mega-urbanisation in Asia: Development Processes and Consequences of Urban Spatial Reorganization*, <http://www.megacities.uni-koeln.de/documentation/megacity/map/MC-2015-PGM.jpg>
- <sup>10</sup> OECD (2011), *Water Governance in OECD Countries: A Multi-level Approach*, OECD Studies on Water, OECD Publishing, [http://www.oecd-ilibrary.org/environment/water-governance-in-oecd-countries\\_9789264119284-en](http://www.oecd-ilibrary.org/environment/water-governance-in-oecd-countries_9789264119284-en)
- <sup>11</sup> Brenna, L., Dyrkoren, P., Vangdal, A., Poulton, M., and Bruaset, S. (2013), *Report on System Development, Method Applicability, and Pipeline Condition Data for Modelling Purposes*. [www.trust-i.net](http://www.trust-i.net)
- <sup>12</sup> <http://www.awwa.org/>
- <sup>13</sup> Kingdom, B., Liemberger, R., and Marin, P. (2006), *The Challenge of Reducing Non-Revenue Water (NRW) in Developing countries*, Water Supply and Sanitation Sector Board Discussion Paper Series, Paper No. 8, December 2007. <http://siteresources.worldbank.org/INTWSS/Resources/WSS8fin4.pdf>
- <sup>14</sup> These reports are available at: <http://www.itu.int/en/ITU-T/focusgroups/ssc/>
- <sup>15</sup> <http://www.un.org/waterforlifedecade/scarcity.shtml>
- <sup>16</sup> [http://www.populationinstitute.org/external/files/Fact\\_Sheets/Water\\_and\\_population.pdf](http://www.populationinstitute.org/external/files/Fact_Sheets/Water_and_population.pdf)
- <sup>17</sup> [http://www.who.int/water\\_sanitation\\_health/mdg1/en/](http://www.who.int/water_sanitation_health/mdg1/en/)
- <sup>18</sup> [http://www.populationinstitute.org/external/files/Fact\\_Sheets/Water\\_and\\_population.pdf](http://www.populationinstitute.org/external/files/Fact_Sheets/Water_and_population.pdf)

- 19 [http://www.un.org/waterforlifedecade/swm\\_cities\\_zaragoza\\_2010/pdf/01\\_water\\_quality\\_and\\_sanitation.pdf](http://www.un.org/waterforlifedecade/swm_cities_zaragoza_2010/pdf/01_water_quality_and_sanitation.pdf)
- 20 <http://www.wri.org/resources/maps/aqueduct-water-risk-atlas>
- 21 Jiménez Cisneros, B.E., T. Oki, N.W. Arnell, G. Benito, J.G. Cogley, P. Döll, T. Jiang, and S.S. Mwakalila, 2014: Freshwater resources. In: *Climate Change 2014: Impacts, Adaptation, and Vulnerability. Part A: Global and Sectoral Aspects. Contribution of Working Group II to the Fifth Assessment Report of the Intergovernmental Panel on Climate Change* [Field, C.B., V.R. Barros, D.J. Dokken, K.J. Mach, M.D. Mastrandrea, T.E. Bilir, M. Chatterjee, K.L. Ebi, Y.O. Estrada, R.C. Genova, B. Girma, E.S. Kissel, A.N. Levy, S. MacCracken, P.R. Mastrandrea, and L.L. White (eds.)]. Cambridge University Press, Cambridge, United Kingdom and New York, NY, USA, pp. 229-269. [http://www.ipcc.ch/pdf/assessment-report/ar5/wg2/WGIIAR5-Chap3\\_FINAL.pdf](http://www.ipcc.ch/pdf/assessment-report/ar5/wg2/WGIIAR5-Chap3_FINAL.pdf)
- 22 Major, D.C., Omojola, A., Dettinger, M., Hanson, R.T., and Sanchez-Rodriguez, R. (2011), Climate Change, Water, and Wastewater in Cities. *Climate Change and Cities: First Assessment Report of the Urban Climate Change Research Network*, Rosenzweig, C., Solecki, W. D., Hammer, S., Mehrotra, S., (Eds), Cambridge University Press, Cambridge, UK, pp. 113–143. <http://uccrn.org/wp-content/uploads/2011/06/ARC3-Chapter-5-Optimized.pdf>
- 23 OECD (2013), *Policies to Support Smart Water Systems: Lessons from Countries Experience*, Working Party of Biodiversity, Water and Ecosystems, OECD Environment Policy Committee, 30-31 May 2012, Paris.
- 24 Berst, J., Enbysk, L., and Williams, C. (2013), *Smart Cities Readiness Guide: The Planning Manual for Building Tomorrow's Cities Today*, Smart Cities Council, <http://www.corviale.com/wp-content/uploads/2013/12/guida-per-le-smart-city.pdf>
- 25 Hauser, A. (2012), *An Architectural Framework for Smart Water Networks*.
- 26 An example of this type of research was conducted by the Department of Mechanical Engineering, North-Western University, Illinois, USA, which developed a "Smart Pipe" prototype in 2009. Further information can be found at: <http://www.isws.illinois.edu/gws/sensor/smartpipe/>.
- 27 <http://www.allianceforwaterefficiency.org/smart-meter-introduction.aspx>
- 28 Examples include "CityCat" developed by Newcastle University. The system uses cloud computing to estimate spatial and temporal flood risk on a city scale. Further information is available at: [http://icfr2013.ex.ac.uk/papers/D3\\_Glenis.pdf](http://icfr2013.ex.ac.uk/papers/D3_Glenis.pdf).
- 29 [http://www.automationworld.com/sites/default/files/styles/lightbox/public/field/image/120723scada\\_web.png?itok=llXV7wPd](http://www.automationworld.com/sites/default/files/styles/lightbox/public/field/image/120723scada_web.png?itok=llXV7wPd)
- 30 Aoun, C. (2013), *The Smart City Cornerstone: Urban Efficiency*. [http://www.digital21.gov.hk/sc/relatedDoc/download/2013/079%20SchneiderElectric%20\(Annex\).pdf](http://www.digital21.gov.hk/sc/relatedDoc/download/2013/079%20SchneiderElectric%20(Annex).pdf)
- 31 Datta, B., and Hari Krishna, V. (2004), *Optimization Applications in Water Resources Systems Engineering*. <http://www.iitk.ac.in/directions/directsept04/bithin~new.pdf>
- 32 Dondeynaz, C., Mainardi, P., Carmona-Moreno, C., I and Leone, A. (2009), *A web based communication and information system tool for water management in developing countries*, 34th WEDC International Conference, Addis Ababa, Ethiopia. [http://wedc.lboro.ac.uk/resources/conference/34/Dondeynaz\\_C\\_-\\_292.pdf](http://wedc.lboro.ac.uk/resources/conference/34/Dondeynaz_C_-_292.pdf)
- 33 [http://www.sweetmaps.com/blog/wp-content/uploads/2011/01/BCC\\_esri\\_flood\\_map.jpg](http://www.sweetmaps.com/blog/wp-content/uploads/2011/01/BCC_esri_flood_map.jpg)
- 34 [http://www.bom.gov.au/water/about/publications/document/InfoSheet\\_3.pdf](http://www.bom.gov.au/water/about/publications/document/InfoSheet_3.pdf)

- <sup>35</sup> Brenna, L., Dyrkoren, P., Vangdal, A. C., Poulton, M., and Bruaset, S. (2013), *Report on System Development, Method Applicability and Pipeline Condition Data for Modeling Purposes D 46.2*, TRUST. <http://www.trust-i.net/downloads/index.php?iddesc=65>
- <sup>36</sup> Trincherro, D., Stefanelli, R., Cisoni, L., Kadri, A., Abu-Dayya, A., Khattab, T., and Hasna, M. (2010), *Wireless sensors as an efficient way to improve sustainability in water management by a significant reduction of water wasting*, ITU-T Workshop "ICTs: Building the green city of the future", Expo-2010, 14 May, 2010, Shanghai, China. <http://www.itu.int/ITU-T/worksem/ict-green/programme.html>
- <sup>37</sup> De Rooij, E., and van Heeringen, K. (2013), *How Delft-FEWS incorporates real-time sensor data with dynamic modelling to allow Real Time Control of sewer systems*, Environmental Software Systems. Fostering Information Sharing IFIP Advances in Information and Communication Technology, Vol. 413, pp. 54-61. [https://www.wageningenur.nl/upload\\_mm/9/a/9/c5a9bd1f-de4d-4cd8-984a-a9544dba9ea8\\_Rooij\\_etal.pdf](https://www.wageningenur.nl/upload_mm/9/a/9/c5a9bd1f-de4d-4cd8-984a-a9544dba9ea8_Rooij_etal.pdf)
- <sup>38</sup> *Ibid.*
- <sup>39</sup> <http://www.hitachi.com/products/smartcity/smart-infrastructure/water/solution.html>
- <sup>40</sup> [http://www.itu.int/dms\\_pub/itu-t/oth/0b/11/T0B110000253301PDFE.pdf](http://www.itu.int/dms_pub/itu-t/oth/0b/11/T0B110000253301PDFE.pdf)
- <sup>41</sup> Carayannis, E. G., and Nikolaidis, Y. (2010) *Enterprise Networks and Information and Communication Technologies (ICT) Standardization*, in Wang, L. and Koh S.C.L. (Eds): *Enterprise Networks and Logistics for Agile Manufacturing*, pp. 99-118, Springer.
- <sup>42</sup> *Ibid.*
- <sup>43</sup> OECD (2012), *Policies to Support Smart Water Systems. Lessons From Countries Experience*, Working Party on Biodiversity, Water and Ecosystems, OECD, Paris, France.
- <sup>44</sup> *Ibid.*

### Bibliography

IEEE 1451 (2009), *Understanding the IEEE 1451 standard in 6lo WPAN Sensor Networks*.



## Glossary

AISUWRS	Assessing and Improving Sustainability of Urban and Water Resources and Systems
AMI	Advanced Metering Infrastructure
AR	Augmented Reality
ART	Acoustic Resonance Technology
BOD	Biochemical Oxygen Demand
COD	Chemical Oxygen Demand
CSO	Combined Sewer Overflow
EM	Electronic Module
EPC	Engineering, Procurement, and Construction
GIS	Geographic Information System
GPRS	General Packet Radio Service
GSM	Global System for Mobile Communications
HAN	Home Area Network
ICT	Information and Communication Technology
IoT	Internet of Things
IPCC	Intergovernmental Panel on Climate Change
ISA	International Society of Automation
LAN	Local Area Network
M2M	Machine-to-Machine
NGO	Non-Governmental Organization
OECD	The Organization for Economic Co-Operation and Development
PARS	Pipeline Analysis and Reporting System
RTC	Real Time Control
SaaS	Software as a Service
SCADA	Supervisory Control and Data Acquisition
SCC	Smart Sustainable City
SMS	Short Message Service
SME	Small-Medium Enterprise
SWM	Smart Water Management
UGROW	Urban Groundwater
UNEP	United Nations Environment Programme
UN-Habitat	United Nations Human Settlements Programme

USN	Ubiquitous Sensor Network
WAN	Wide Area Network
WiFi	Wireless Fidelity
WPCP	Wastewater Pollution Control Plant
WWTP	Wastewater Treatment Plant









# 3.7

## Information and communication technologies for climate change adaptation in cities

Technical Report

## Acknowledgements

This Technical Report was researched and written by Daniela Torres (Telefónica) and Motsomi Maletjane (UNFCCC) as a contribution to ITU-T Focus Group on Smart Sustainable Cities (FG-SSC) and in alignment with ITU-T SG5 Question 15/5 mandate to study issues related to ICTs and climate change adaptation.

Authors would like to thank specially to Melissa Ilboudo (University of East Anglia, UK), Angelica V Ospina (University of Manchester) and Mythili Menon (University of Geneva) for their valuable technical contribution to this Report. We also thank to Nevine Tewfik (Ministry of Communications and Information Technology of Egypt); Tiffany Hodgson (UNFCCC); to Monica Salvia and Filomena Pietrapertosa (National Research Council of Italy – Institute of Methodologies for Environmental Analysis (CNR-IMAA), Italy); Hisashi Sakaguchi and Yasuyuki Koga (National Institute of Information and Communications Technology (NICT) Japan); Hiroko Ioka (Fujitsu) for their helpful review and contribution.

For additional information and materials relating to this Report and to the work of ITU-T Study Group 5 (SG5) on adaptation for climate change, please visit <http://www.itu.int/en/ITU-T/studygroups/2013-2016/05/Pages/default.aspx>.

More information about SG5 Question 15/5 on “ICTs and adaptation to the effects of climate change” is available at <http://www.itu.int/en/ITU-T/studygroups/2013-2016/05/Pages/q15.aspx>.

If you would like to provide any additional information, please contact Cristina Bueti at [tsb5@itu.int](mailto:tsb5@itu.int).

## Table of Contents

		Page
<b>1</b>	<b>Introduction .....</b>	<b>549</b>
1.1	Scope .....	549
<b>2</b>	<b>Climate change adaptation in cities .....</b>	<b>549</b>
2.1	Climate change risks, vulnerabilities and impacts in cities .....	550
2.2	Approaches to climate change adaptation in cities .....	555
<b>3</b>	<b>The role of ICTs in climate change adaptation in cities.....</b>	<b>559</b>
3.1	ICTs for enhanced disaster risk management (DRM).....	560
3.2	ICTs for city resilience and adaptive capacity .....	563
3.3	ICTs for informed adaptation decision making .....	570
<b>4</b>	<b>Framework for ICTs' integration in cities climate change adaptation plans.....</b>	<b>572</b>
4.1	Engaging stakeholders for the integration of ICTs in climate change adaptation plans in cities.....	573
<b>5</b>	<b>Smart sustainable cities' adaptation checklist.....</b>	<b>575</b>
	<b>Conclusion.....</b>	<b>577</b>
	<b>Bibliography .....</b>	<b>579</b>





## Information and communication technologies for climate change adaptation in cities

### Executive Summary

"Adaptation is the only means to reduce the now-unavoidable costs of climate change over the next few decades" – Sir Nicholas Stern, 'The Stern Review' on economics of climate change, October 2006.

This Technical Report has been prepared within the Focus Group on Smart Sustainable Cities (FG-SSC) and responds to the need to explore how Information and Communication Technologies (ICTs) and their infrastructure can support cities' adaptation to climate change. It is a contribution to the ongoing work on climate change adaptation within Question 15/5 of ITU-T Study Group 5, which leads ITU-T standardization activities on ICT and environmental aspects of climate change.

The first part of the Report describes in general terms the impacts of climate change in cities, providing an overview of the main risks and vulnerabilities they are facing. Climate change negatively impacts the cities' infrastructure, including ICT infrastructure, affects key sectors of the economy such as the agriculture and construction sector, and, above all, it compromises the citizens' quality of life as it may affect the provision of key public services (e.g., health, water supply and sanitation, energy provision, waste management, mobility), urban planning and food security, which are all crucial dimensions for sustainable development. Within this framework of challenges, the report highlights the importance for municipalities to improve their capacity to respond to the challenges posed by climate change, and introduces the need to include ICTs in climate change adaptation policies in cities, as a key element for the establishment of smart sustainable cities (SSC).

The second part of the report expands on the contribution of ICTs by identifying their role in helping cities to adapt to climate change. The analysis acknowledges that ICTs have the potential to play a leading role in climate change adaptation in cities, while also adapting its own physical infrastructure. In this sense, this report establishes three main areas where ICTs can support cities' adaptation policies which are as follows: (1) the development of effective climate-related disaster risk management programs in cities; (2) the early stage of urbanization planning, by providing high quality data and information to help cities' planners to cope with climate change and build resilient cities; and (3) facilitation of communication and exchange of information between the relevant stakeholders involved in climate change adaptation for informed decision making. This section includes practical examples of the use of ICTs for climate change adaptation in several cities of the world, to better understand their role in addressing these challenges.

In the last section, the report suggests a series of ICT-based policies and strategies that could be used by city mayors to adapt to climate change and build resilient cities with the support of ICT tools and services. The report invites urban stakeholders interested in novel approaches to sustainability to integrate the use of ICTs in their climate change adaptation strategies and policies. It presents a framework that could be used by cities not only to adapt to climate change, but also to build resilient cities. The framework builds upon a multi-sectoral vision of urban planning, highlighting the key role of ICTs and cross-sectoral adaptation policies. It proposes an ICT-based policy process for city mayors and planners, which covers all phases of a common adaptation process (observation, assessment, planning, implementation and monitoring).



The following are the key steps of adaptation planning and implementation, and the potential contribution of ICTs to each the step:

- 1) **Setting the basis: Observation and understanding:** city planners should consider the role of ICTs in climate change adaptation as a new alternative in their local adaptation plans. They should take stock of existing measures, opportunities and challenges on the integration of ICTs in climate change adaptation.
- 2) **Assessing climate change risks and vulnerabilities:** this should involve an assessment of how ICTs can support to identify adaptation options to climate change, as well as to carry out an assessment of the specific risks and vulnerabilities on ICT infrastructure.
- 3) **Planning of adaptation options:** for planning of the adaptation process, it is important to define the role of ICTs in identifying adaptation options for cities, as well as those options that would allow for the use of ICTs for impacts of climate change. Once the potential adaptation options are identified, an assessment should be carried out to determine which of them suit the cities specific context. The approach is based on prioritizing those ICTs that would best support adaptation options in a given city context, including the evaluation of social, environmental and economic variables. This step also involves the prioritization of adaptation options for the ICT infrastructure.
- 4) **Implementation of adaptation actions:** this step relates to the development of an implementation plan to convert adaptation options into action. It involves the integration of ICTs in the design of implementation strategies for identified/prioritized adaptation options, together with the implementation of specific adaptation options for the city's ICT infrastructure.
- 5) **Monitoring and evaluating adaptation actions:** this step consists of a monitoring system and evaluation of the role on ICTs in climate change adaptation, to ensure the focus and effectiveness of adaptive actions. ICTs have the capacity to support this process in various ways including (but not limited to) usage of software tools to enable modelling, monitoring and analysis of climate change impact in cities. A smart sustainable cities' adaptation checklist is also provided in the last chapter of this report, to enable cities mayors to evaluate the degree of inclusion of ICTs in their cities strategic responses, and assist them in improving relevant adaptation interventions.

## 1 Introduction

---

Climate change is a serious challenge for cities around the world. The Intergovernmental Panel on Climate Change (IPCC) 5<sup>th</sup> assessment report indicates that:

*"The warming of the climate system is unequivocal, and since the 1950s, many of the observed changes are unprecedented over decades to millennia. The atmosphere and ocean have warmed, the amounts of snow and ice have diminished, sea level has risen, and the concentrations of greenhouse gases have increased"<sup>1</sup>*

Although rapid urban growth is often seen as contributing to climate change and environmental degradation, cities forming the epicentre of urban growth, can also be highly vulnerable to the effects of climate change. Climate change threatens to increase vulnerability, undermine economic gains, hinder social and economic development, and worsen access to basic services and the quality of life of citizens. Therefore, it is imperative for cities to adapt to climate change.

ICTs have the potential to play a leading role in climate change adaptation. It can help enhancing and improving climate change adaptation strategies in cities.

This Technical Report has been developed within the Focus Group on Smart Sustainable Cities (FG-SSC) and responds to the need to explore how ICTs can support cities' adaption to climate change. In addition, it has also been developed with the aim of contributing to the ongoing work on climate change adaptation within Question 15/5 of ITU-T Study Group 5, which is the lead ITU-T study group on ICT environmental aspects of climate change. In particular, this report seeks to contribute to the development of a Recommendation for the integration of ICTs in climate change adaptation programs in cities.

### 1.1 Scope

The report describes the impacts of climate change in cities and explains why cities need to adapt to its harmful effects. This report moves on to explore the crucial role that ICTs can play in helping cities to adapt to climate change. It presents an ICT-based framework for climate change adaptation to assist policy makers in developing effective adaptation strategies and building resilient cities. After identifying the key stakeholders involved in urban climate change adaptation strategies, the report concludes with a checklist to assess ICTs' integration into the city's climate change adaptation plan, and to identify aspects that could be strengthened in the local adaptation planning and response.

The report is aimed at a broad audience of stakeholders interested in ICTs, climate change adaptation, and Smart Sustainable Cities, including city decision makers and planners.

## 2 Climate change adaptation in cities

---

Cities have started to address climate change by making efforts to reduce their emissions, putting in place several mitigation actions such as sustainable transport strategies, waste management systems, establishing building codes or by promoting enhanced use of renewable energy. However, GHG emissions continue to rise and cities are starting to feel the effects of climate change impacts,

---

<sup>1</sup> IPCC Report – Summary for policy makers, pg. SPM3.

evidencing the need for them to adapt to both current and future manifestations (UN-HABITAT, 2012).

The following section of the report explores the main climate change risks, vulnerabilities and impacts that cities are facing, and will likely face in the foreseeable future. The analysis also addresses, in general terms, how cities are adapting to these risks and vulnerabilities. This will set the basis to provide an understanding of how cities can apply ICTs as an enabler to better adapt to climate change. Box 1 presents some of the key definitions used as the basis for the analysis.

### Box 1. Key definitions

*Climate change* refers to a change of climate that is attributed directly or indirectly to human activity that alters the composition of the global atmosphere and that is in addition to natural climate variability observed over comparable time periods.

*Adaptation* refers to adjustments in ecological, social, or economic systems in response to actual or expected climatic stimuli and their effects or impacts. It refers to changes in processes, practices, and structures to moderate potential damages or to benefit from opportunities associated with climate change (IPCC, 2007).

*Vulnerability to climate change* is the degree to which geophysical, biological and socio-economic systems are susceptible to, and unable to cope with, adverse impacts of climate change. Vulnerability can be described using the following components: exposure, sensitivity and adaptive capacity (IPCC, 2007).

*Adaptive capacity* (in relation to climate change impacts): The ability of a system to adjust to climate change (including climate variability and extremes) to moderate potential damages, to take advantage of opportunities, or to cope with the consequences (IPCC, 2014).

Sources: UNFCCC (2014) [http://unfccc.int/essential\\_background/convention/background/items/2536.php](http://unfccc.int/essential_background/convention/background/items/2536.php)

IPCC (2007). "Climate Change 2007: Working Group II: Impacts, Adaptation and Vulnerability" [http://www.ipcc.ch/publications\\_and\\_data/ar4/wg2/en/annexessglossary-a-d.html](http://www.ipcc.ch/publications_and_data/ar4/wg2/en/annexessglossary-a-d.html)

IPCC Glossary (2014) [http://www.ipcc.ch/publications\\_and\\_data/ar4/wg2/en/annexessglossary-a-d.html](http://www.ipcc.ch/publications_and_data/ar4/wg2/en/annexessglossary-a-d.html)

## 2.1 Climate change risks, vulnerabilities and impacts in cities

There is an increasing recognition of the potential impacts of climate change in cities. Cities contribute to a large portion of a country's Gross Domestic Product (GDP), therefore they are the dominant hubs of economic activities for every nation (Hallegate and Corfee-Morlot, 2011). Climate change may affect urban economic activities and services, thereby damaging important sectors and services including water supply and sanitation, agriculture, urban planning, mobility, building infrastructure, energy, health, waste management and food security, among others.

Cities sectors are interconnected, and therefore, a failure in one sector (e.g., in the case of extreme weather events) could have a 'domino effect' on other cities sectors and lead to an overall economic loss for a country or region (GTZ, 2009). Studies suggest that windstorms and floods that took place in Asia between 1996 and 2005 caused over 70,000 deaths, with an estimated economic loss of around US\$ 190 billion. A large part of this loss is due to the lack of resilient and adequate infrastructure, including ICT infrastructure.

Similarly, rapid urbanisation and population growth can worsen the impacts of climate change in cities. The Department of Economic and Social Affairs of the United Nations (UNDESA), has estimated that by 2050, about 70% of the world's population is expected to live in urban areas and over 60% of the land projected to become urban by 2030 is yet to be built. This high concentration

of population and economic activity makes cities particularly vulnerable to climate change (UNDESA, 2014).

The effects of climate change will be felt by cities with varying degrees of intensity. Evidence from the field indicates that climatic changes such as variation in rainfall or temperature patterns and sea level rise are having an impact on development dimensions such as agricultural production, food supply, water supply, health and disease proliferation (etc.) in cities. Cities in both developed and developing countries are vulnerable to the effects of climate change. Cities located in developing countries are particularly susceptible due to their limited resources and capacity to adapt and recover from climatic extreme events.

Climate change impacts in cities also depend on the cities' geographical location. For instance, low elevation coastal zones will face the combined threats of sea level rise and storm surges, while cities in hot climates may be affected by longer and more severe heat waves. Ultimately, cities, located in port or coastal lines and inland cities are and will be affected by climate change.

Cities are the main engine for growth and development. They drive all national economies and generate substantial wealth. Any abrupt disruption that can occur has the potential to negatively affect cities' productivity with impacts on public services and wealth. For example, if European economic hubs such as London, Paris, or Rotterdam experience climate related problems, Europe's economy and quality of life can be affected (EEA, 2012). Moreover, climate change impacts could also hamper the ability of developing nations in achieving the Millennium Development Goals or working towards the Post 2015 Development Agenda. The impacts of climate change may also raise barriers to overcoming poverty and marginalization in urban areas (ITU, 2012). As such, it is essential that cities should take the require action aiming at strengthening their infrastructure and adapting to new climatic conditions.

Many cities already are undertaking various measures to adapt to the climate change risks and vulnerabilities as reflected in the examples included below:

- **Coastal Cities:** these cities tend to be more concentrated in low coastal zones and are exposed to extreme coastal water level events. 65% of cities in the world with population greater than 5 million located are in these areas; on which some of them are already below normal high-tide levels and prone to flooding and storm surges. The most threatened coastal urban environments include deltas, low-lying coastal plains, islands and barrier islands, beaches and estuaries (Hunt and Watkiss, 2011). Cities facing these challenges are located across the globe, independently if they are in developed or developing countries. Some examples of cities facing these challenges include New Orleans, New York, Los Angeles, Tokyo, Amsterdam, Mumbai, Shanghai, Singapore, Jakarta and Dhaka (OECD, 2007).
- **Inland cities:** they are found in the interior part of the mainland. These cities like their coastal counterparts are also at risk. Settlements located along rivers are specifically considered 'high risk locations'. Inland cities will also face an increase in flooding potential due to more sizeable rainfall events. Equally, Changes in climate that reduce precipitation and impair underground water will have impact on water resource availability especially in semi-arid and arid areas in both developed and developing cities (UN-HABITAT, 2009).

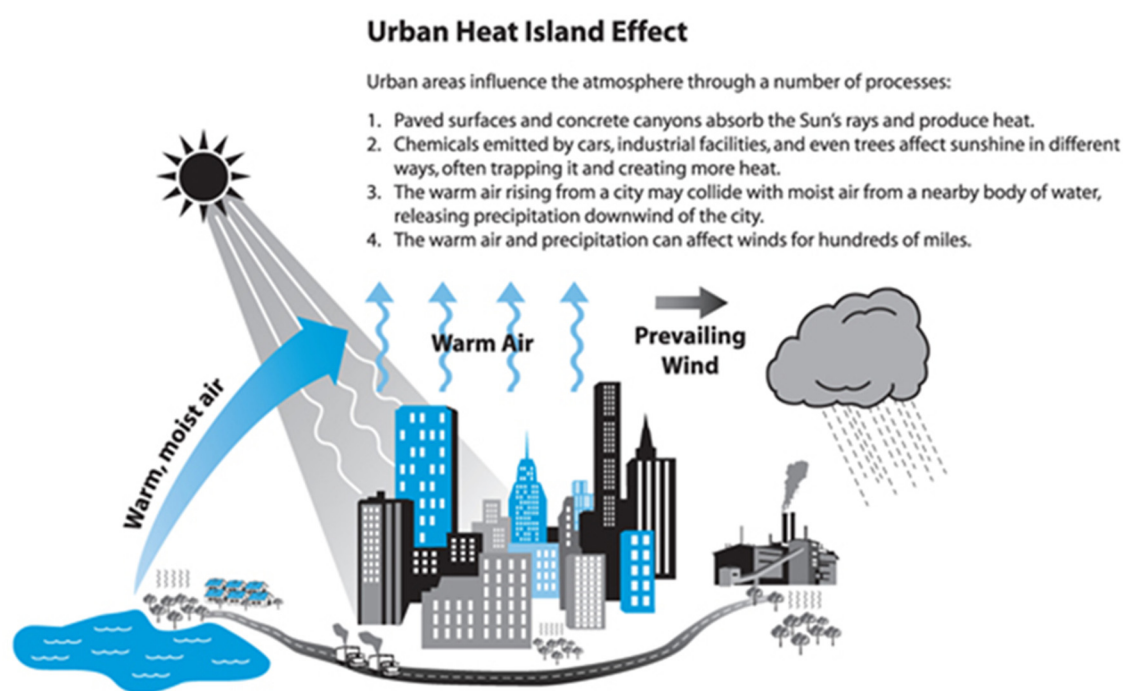
Climate change has a range of short-term and long-term consequences on cities. It will have both direct and indirect impacts on human health, physical assets, economic activities, and social systems depending on how well prepared a city is, and how it responds (World Bank, 2011). The direct impacts of climate change in cities depend mainly on exposure to heat or cold waves, as well as to extreme weather events that can translate into storms, floods, and droughts, related landslides and wildfires. Indirect impacts are a consequence of the aforementioned events, for example food or



water-related infections, diseases, people displacement, adverse psychological effects, and other stresses (IPCC, 2007).

Some examples of direct and indirect impacts of climate change in cities include:

- Increased temperature:** heat stress represents a serious public health concern especially in summers. Urban residents are particularly at risk of heat stress given the fact that higher temperatures occurs in urban regions more than in rural areas due to the 'urban heat island effect' (displayed in Figure 1). Illustrating these impacts, the 2003 summer heat wave in Western Europe has been linked to 35,000 deaths (UN-HABITAT, 2009). Indirect impacts include the overstress of energy transmission and distribution, due to the increased incidence or duration of summer heat waves, in conjunction with high energy demand for cooling (IEA, 2013).



Source: UCAR (University Corporation for Atmospheric Research) (2009)

**Figure 1 – The urban heat island effect**

- Heatwaves:** these events could reduce the ability to work and result in lower productivity thereby shortening or delaying the delivery of products and services to clients within the city and elsewhere. They can reduce the use of public spaces and thus constrain social life. High temperatures can put infrastructure at risk, including ICT Infrastructure, as fluctuating heat levels can cause continuous thermal expansion and contraction of roads and railroad tracks, physically weakening the construction infrastructure and in the process hamper the supply of goods and movement of commuters. This also adds to maintenance costs (in terms of labour as well as finances) of these structures. (EEA, 2012).
- Sea level rise:** rise in sea level is one of the most well-known effects of climate change which has proved detrimental to human life and property. One common cause of sea level rise is accelerated glacial melting as a result of increased temperatures due to global warming. Such rises in sea level are unpredictable, and can cause coastal flooding that may lead to loss of life and property (UNFCCC, 2012). Other direct effects of sea level rise include inundation and displacement, coastal erosion and land loss, increased storm flooding and damage, increased salinity in estuaries and coastal aquifers, rising coastal water tables and impeded drainage.

Indirect impacts have been linked to changes in the distribution of sediments, changes in the functioning of coastal ecosystems, and impacts on recreational/tourism activities (Hunt and Watkiss, 2011).

- **Droughts:** climate change is also known to cause changes in the global water cycle. The fluctuations in temperatures caused by climate change can lead to significant changes in precipitation patterns whereby areas that were previously receiving adequate rains may face drought, while other regions experience flooding. Cities are likely to face water stress, which will have a direct impact on energy supply sourced from hydropower. Furthermore, areas affected by droughts are likely to face land degradation with low agricultural yield and increased risk of food shortage. Indirect impacts can include reduced water quality and availability due to an increase in droughts, especially from sources (e.g., snowpack) outside of city borders. This can threaten the drinking water supply and reduce agricultural production, affecting food security in cities (World Bank, 2011). Other indirect impacts include greater in-migration from rural inhabitants pressured by drought or other climate extremes.
- **Floods:** these events can destroy homes, business sites and infrastructure, as well as contribute indirectly to the loss of employment and other income sources. People and business could have limited access to vital services such as energy, transport and clean water, with the subsequent impact on health (EEA, 2012). Floods also have an indirect effect on the health infrastructure and other lifeline systems in terms of reduced access to energy, transport, food and sanitation services (ibid).
- **Human health:** climate change is likely to affect human health in cities, either directly or indirectly. Impacts can range from physiological effects of heat and cold, or indirectly, through the transmission of vector-borne pathogens or effects on personal well-being from flooding episodes (Hunt and Watkiss, 2011). Impacts of climate change may also facilitate the transmission of vector borne (e.g., malaria, dengue and dengue hemorrhagic fever, yellow fever, and West Nile Fever) and water borne diseases (e.g., typhoid fever, cholera, leptospirosis and hepatitis A). According to the World Health Organization (WHO) "*between 2030 and 2050, climate change is expected to cause approximately 250 000 additional deaths per year, from malnutrition, malaria, diarrhea and heat stress*" (WHO, 2014).
- **Global security:** climate change is seen as a threat to the well-being, safety, and survival of people around the world, although more evidence is needed to understand the nature of this relationship (World Bank, 2011). Increasing water stress due to climate change can lead to mass migration to urban areas. This increase in urban population may cause conflict for scarce natural resources, leading to security concerns in affected regions. In 2011, the UN Security Council declared that the adverse effects of climate change would trigger or aggravate international and national peace and security issues. (UN, 2011)

Table 1, provides a comprehensive list of examples of climate change impacts in cities as a guide to understand the link between direct and indirect impacts. The specific impacts on each city will depend on the actual changes experienced, and on their geographical location, among other factors. Figure 2 depicts the risk heat map of the projected climate change impact.

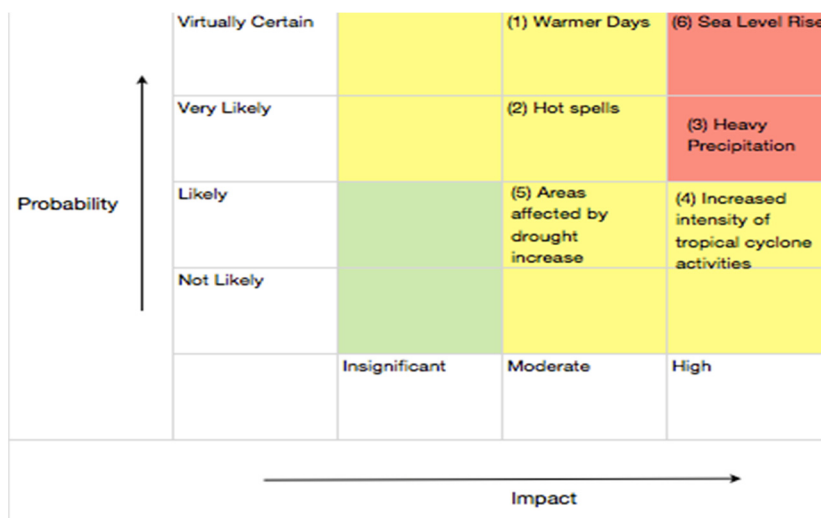


Figure 2 – Risk Heat Map of the potential climate change impacts

Table 1 – Examples of direct and indirect impacts of climate change in cities

Projected climate change impacts	Likelihood	Direct impacts	Indirect impacts	Geographical location affected
<b>(1) Warmer with fewer cold days and nights, more hot days and nights</b>	Virtually certain	Exacerbation of urban heat island effect increases risk of related mortality.	Declining air quality.	Inland cities and cities reliant on snowpack for water supply.
<b>(2) Hot spells/heat waves increased frequency</b>	Very likely	Increased demand for cooling, and reduced energy demand for heating. Greater stress on water resources included those that rely on snowmelt from increased water demand and declining water quality.	Energy transmission and distribution maybe overstressed Wider geographical incidence of vector bone diseases ( for example malaria) Less disruption to transport from snow and ice.	Inland cities and cities reliant on snowpack for water supply.
<b>(3) Heavy precipitation events increased frequency</b>	Very likely	Flooding, strong winds and landslides. Disruption of public water supply.	Withdrawal of risk coverage in vulnerable areas by private insurers.	Coastal and port cities, those on riverbanks or marginal land in floodplains, mountains regions.

**Table 1 – Examples of direct and indirect impacts of climate change in cities**

Projected climate change impacts	Likelihood	Direct impacts	Indirect impacts	Geographical location affected
<b>(4) Intensity of tropical cyclone activity increases</b>	Likely	Damage and losses of physical assets and infrastructure. Increased risk of death, injuries and illnesses. Disruption of transport, commerce and economic activities.	Impacts on tourism and local livelihoods, psychological impacts/stress of vulnerable populations.	Coastal and port cities.
<b>(5) Areas affected by drought increase</b>	Likely	Stress on water resources Reduced energy supply from hydropower. Land degradation with lower agricultural yields, increased risk of food shortage and dust storms.	Water quantity and quality for consumption and food production Population migration.	Cities unused to arid conditions.
<b>(6) Rising sea level</b>	Virtually certain	Permanent erosion and submersion of land. Cost of coastal protection or cost of relocation. Decreased ground water availability. Increase salinity in estuaries & coastal aquifers. Effects of tropical cyclones and storm surges, particularly coastal flooding.	Recreational activities are affected.	Coastal cities.

Source: Compiled from World Bank (2011) and Hunt and Watkiss (2011)

## 2.2 Approaches to climate change adaptation in cities

A number of cities have developed adaptation strategies, frameworks and/or plans using different approaches. These range from sector plans, strategic plans focusing on specific themes or risks, to broader holistic plans that integrate the various approaches and/or different aspects in a city. Selected examples are listed below:

- The New York City adaptation approach followed a multistep process that included identification of climate hazards and impacts, developing and evaluating adaptation strategies, implementing actions, and monitoring results. The work was led by the New York City Climate Change Adaptation Task Force, with the assistance of the New York City Panel on Climate Change (Rosenzweig and Solecki, 2010).

- In developing its climate change strategy, the Durban Municipality identified a set of ten interrelated climate change response themes: water, sea level rise, biodiversity, food security, health, energy, waste and pollution, transport, economic development, and knowledge generation and understanding. The approach included the development of a separate implementation framework, and a monitoring and evaluation system (DCCS, 2014).
- The Hanoi climate change vulnerability assessment approach involved a ten step process, following the UN-HABITAT's Cities and Climate Change Initiative:
  - establishing contact with the city government, gaining participation at city level and forming an assessment team;
  - identifying key issues through disaster profile and climate change scenarios for 2020, 2050 and 2100; developing the city profile;
  - mapping and mobilizing key stakeholders; consulting with local communities, government and private sector;
  - identifying the main climate hazards for Hanoi;
  - analysing sensitivity of the city infrastructure and physical systems;
  - developing adaptive capacity analysis based on evaluation of technology, human and financial resources, policy and mechanism and coordination and implementation capacity;
  - identifying hotspot areas based on disaster profile, modelling, stakeholder interviews and community mapping; and conducting city feedback and evaluation meeting; and
  - identifying priority actions and planning for implementation (UN-HABITAT, 2014).
- London's climate change adaptation strategy contains seven tasks to be undertaken in order to manage risks and increase resilience. These are: (i) analysing how London is vulnerable to weather-related risks today (establishing a baseline to assess how these risks change), (ii) using projections from climate models to identify how climate change may accentuate existing risks and create new risks or opportunities in the future, (iii) prioritising the key climate risks and opportunities for London, (iv) providing a framework, (v) establishing a strategic process by which London can put in place the measures necessary to adapt to future climate change, (vi) recommending how London should capitalise on the opportunities presented by climate change; and demonstrating how London can become an international referent on adaptation (GLA, 2011).

In order to guide countries in their overall adaptation planning and implementation, a national adaptation plan (NAP) process has been put in place under the United National Framework Convention on Climate Change (UNFCCC). The NAP process provides an opportunity for countries to consolidate overall adaptation activities, and embark on a coherent and strategic adaptation approach. It is designed to assist countries to reduce vulnerability to the impacts of climate change, by building adaptive capacity and resilience, and to facilitate the integration of climate change adaptation into development planning processes and strategies within all relevant sectors and at different levels.

The process is framed along four elements: laying the groundwork and addressing gaps; preparatory elements; implementation strategies; and reporting, monitoring and review. Table 2 below provides an overview of the steps involved in the adaptation cycle along those four elements:

**Table 2 – Steps under each of the elements of the formulation of National Adaptation Plans (NAP) which may be undertaken as appropriate**

<b>Element A - Lay the groundwork and address gaps</b>
<ol style="list-style-type: none"> <li>1. Initiating and launching of the NAP process</li> <li>2. Stocktaking: identifying available information on climate change impacts, vulnerability and adaptation and assessing gaps and needs of the enabling environment for the NAP process</li> <li>3. Addressing capacity gaps and weaknesses in undertaking the NAP process</li> <li>4. Comprehensively and iteratively assessing development needs and climate vulnerabilities</li> </ol>
<b>Element B - Preparatory elements</b>
<ol style="list-style-type: none"> <li>1. Analyzing current climate and future climate change scenarios</li> <li>2. Assessing climate vulnerabilities and identifying adaptation options at the sector, subnational, national and other appropriate levels</li> <li>3. Reviewing and appraising adaptation options</li> <li>4. Compiling and communicating national adaptation plans</li> <li>5. Integrating climate change adaptation into national and subnational development and sectorial planning</li> </ol>
<b>Element C - Implementation strategies</b>
<ol style="list-style-type: none"> <li>1. Prioritizing climate change adaptation in national planning</li> <li>2. Developing a (long-term) national adaptation implementation strategy</li> <li>3. Enhancing capacity for planning and implementation of adaptation</li> <li>4. Promoting coordination and synergy at the regional level and with other multilateral environmental agreements</li> </ol>
<b>Element D - Reporting, monitoring and review</b>
<ol style="list-style-type: none"> <li>1. Monitoring the NAP process</li> <li>2. Reviewing the NAP process to assess progress, effectiveness and gaps</li> <li>3. Iteratively updating the national adaptation plans</li> <li>4. Outreach on the NAP process and reporting on progress and effectiveness</li> </ol>
<p>Source: LDC Expert Group, 2012. National adaptation plans: Technical guidelines for the national adaptation plan process.  <a href="http://unfccc.int/resource/docs/publications/publication_ldc_nap_techguidelines.pdf">http://unfccc.int/resource/docs/publications/publication_ldc_nap_techguidelines.pdf</a></p>

This framework can be applied at national level and sub-national levels. As the examples reflected in Boxes 2 and 3 suggest, the general considerations on adaptation planning adopted by many cities around the world, in both developed and developing countries, are in line with the elements under the NAP process, as per the general framework described above.



**Box 2. Climate change adaptation in Quito, Ecuador**

Quito's Climate Change Strategy (QCCS) includes a range of innovative programs that combine risk reduction with institutional capacity building and enhanced citizen participation. Within an urban context characterized by intense seismic activity and a landscape of steep slopes, ravines and gorges, recurrent floods, earthquakes and landslides cause extensive damage, particularly in informal settlements located on steep hillsides or in the urban periphery.

Since 2009, the QCCS is an official municipal environmental policy. It is organized under four strategic areas: (1) access to adequate information to promote adaptation and reduce vulnerabilities, (2) use of good environmental practices for adaptation, (3) focus on communication, education, and citizen participation, and (4) strengthening institutional capacities for climate change adaptation.

Source: Evidence and Lessons from Latin America (ELLA) (2013) City-level climate change adaptation strategies: The case of Quito, Ecuador. [http://ella.practicalaction.org/sites/default/files/130225\\_ENV\\_CitAdaMit\\_BRIEF1.pdf](http://ella.practicalaction.org/sites/default/files/130225_ENV_CitAdaMit_BRIEF1.pdf)

**Box 3. Climate change adaptation in the city of Melbourne**

The City of Melbourne is expected to be significantly affected by warmer temperatures and heatwaves, reduced rainfall and drought, bushfire, intense rainfall and windstorm, and sea level rise. In order to address these challenges, the city has embarked on a citywide adaptation plan that builds on an urban system assessment (covering the current state and potential climate change impacts on water, transport and mobility, building and property, social, health and community, businesses and industry, energy and telecommunications, and emergency systems. It recognizes the following key principles (among others):

- (1) Delivering on a leadership approach to climate adaptation requires engagement with key stakeholders to ensure climate change risks are incorporated into decision making.
- (2) Ensuring that all adaptation efforts underway are consolidated under a framework of reducing climate risks, collaboratively, to deliver the greatest benefits at the least cost.
- (3) Adaptation to climate change cannot ignore the subtleties of the everyday changes, such as overall higher temperatures and reduced rainfall. Such impact over time must be considered, particularly in the design and maintenance of infrastructure, parks and gardens.

Source: Australian Government (2009) City of Melbourne climate change adaptation strategy, [https://www.melbourne.vic.gov.au/AboutCouncil/PlansandPublications/strategies/Documents/climate\\_change\\_adaptation\\_strategy.PDF](https://www.melbourne.vic.gov.au/AboutCouncil/PlansandPublications/strategies/Documents/climate_change_adaptation_strategy.PDF)

It is important to acknowledge that adaptation efforts rely on different types of technologies, as cities are dynamic and growing every day. While many cities have shown considerable advances in the design and implementation of adaptation plans, ICT remain, for the most part, absent from those strategies. As stated previously, this report focuses on the role of ICTs in cities' adaptation initiatives, particularly as part of Smart Sustainable Cities' strategies. These issues will be explored in the following sub-sections.

### 3 The role of ICTs in climate change adaptation in cities

---

The complexity of urban contexts poses new challenges to the process of developing and implementing climate change adaptation strategies. However, it also offers new opportunities for the ICT sector to contribute to climate change adaptation in cities. Cities that are in the process of becoming smart and sustainable, have an enormous opportunity to include ICT infrastructure and ICT solutions as part of their climate change adaptation strategies to respond more effectively to both current and future climate change challenges. Most of the urban infrastructure that will exist in 40 to 50 years has not been built yet (ITU, 2012). The ICT sector can be an enabler of climate change adaptation in cities, but the sector itself has to adapt to climate change in order to guarantee the continuity of essential ICT-related services provision.

The relationship between ICTs and climate change adaptation is not intuitive, but during the last few years, there have been a number of different studies and reports published on this subject, especially by the ITU and UNFCCC. Examples of these include: the *Resilient pathways: the adaptation of the ICT sector to climate change report* or the study *Information and communication technologies (ICTs) and climate change adaptation and mitigation: The case of Ghana*. These reports have identified the opportunities and potential of the ICT sector to support climate change adaptation on a global level, including the adaptation of the sector itself to climate change impacts. This report is the first on its kind to put an emphasis on ICTs for climate change adaptation in cities.

There is a growing number of experiences of ICTs use to support countries to better adapt to climate change. Examples include remote sensing for monitoring of natural disasters such as floods and tidal waves, improved communications to help deal with natural disasters more effectively, or satellite and surface-based remote sensors for environmental observation. Other examples related to the use of ICT tools for climate monitoring and to provide data for climate change prediction on a local basis, among others. ICTs' role in support of climate change adaptation requires further analysis.

This section is intended to highlight the role of ICTs in cities climate adaptation based on three approaches. The first one based on the understanding of the needs of climate change adaptation policies and initiatives in cities. The second based on the experience and research carried out by ITU, ITU-T SG5 and Q15/5 towards the development of standards for ICTs and climate change adaptation and the use of ICTs for disaster risk management. Finally, the role of ICTs can be defined based on different examples of cities that have implemented ICT-based programs to advance in their climate change adaptation plans.

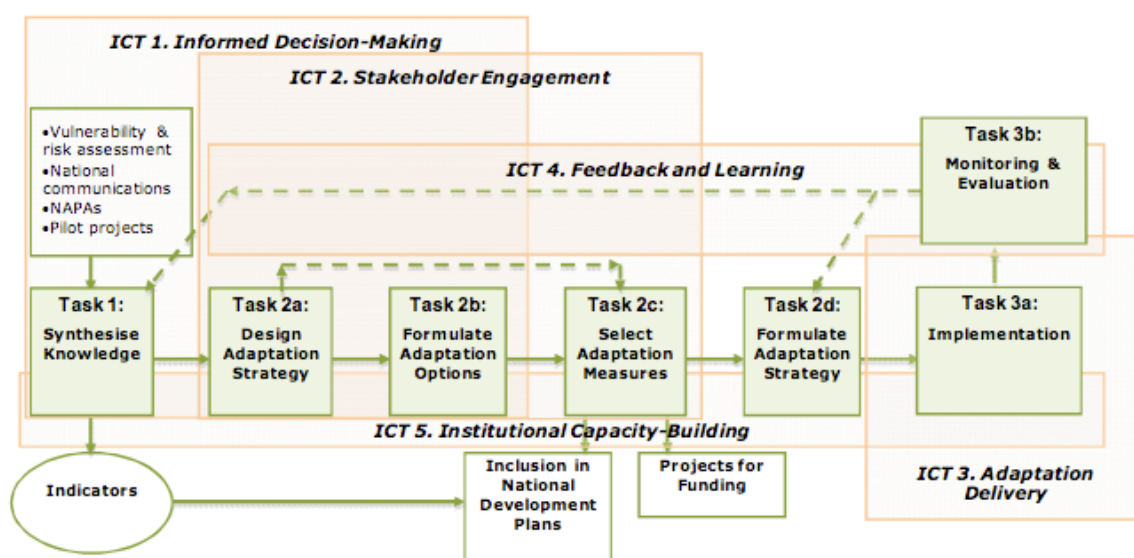
According to the World Bank initiative on "*Cities and climate change leadership*", over-arching adaptation policies must include an integrated approach on strategies for disaster risk management (DRM), poverty reduction and city resilience. ICT tools can deliver clear solutions for the disaster risk management processes and also across planning activities for resilience. Within this framework and with the support of ICTs, climate adaptation strategies in cities can be improved and new long-term pro-active solutions can be carried out for DRM and city resilience initiatives.

These adaptation strategies require robust ICT infrastructures and also specific standards to enhance its use. Different types of disasters and adaptation challenges may require different ICTs solutions. Along with communication technologies and infrastructure, the development of ICT standards are also required for effective inclusion of ICTs in city adaptation programs; and helping to strengthen cities' response to climate change adaptation worldwide. Standards can facilitate massive rollout of technologies and procedures across cities. For instance, the ITU-T Focus Group on disaster relief systems, network resilience and recovery had been tasked to study the

development of standards for disaster relief systems and to advance the work the recovery and resilience of network infrastructure.

Finally it is important to highlight the potential role that ICTs have to promote informed decision making in the adaptation processes. According to research on the role of ICTs in the formulation of climate change adaptation strategy at the national level (Ospina and Heeks, 2011), ICTs can support adaptation strategies within the three broad categories: a) generating information and knowledge; b) capturing and storing information and knowledge; and c) processing and disseminating information and knowledge among an increasingly interconnected society.

Figure 3 illustrates the process of the formulation process of a climate change adaptation strategy at national level; which can be applicable to cities.



Source: Ospina and Heeks (2011), adapted from UNDP (2004)

**Figure 3 – ICTs and the formulation process of climate change adaptation strategies at a national level**

Considering this, ICTs' use for climate change adaptation can be grouped in three strategic categories: (1) ICTs for enhanced disaster risk management; (2) ICTs to improve city resilience and adaptive capacity; and (3) ICTs for informed adaptation decision making. The following section provides an overview of these categories, including selected examples of the application of ICTs in cities to address these challenges.

### 3.1 ICTs for enhanced disaster risk management (DRM)

Climate change action plans in cities include adaptation strategies based on Disaster Risk Management (DRM) programs. These provide a well-proven framework and tool-set for cities to address natural disasters, and help cities explore strategies *before* disasters occurs, as well as *during and after* disasters take place. ICTs facilitate communication and exchange of information between local governments, communities and all relevant stakeholders involved in the DRM processes. ICTs are very important for disaster prevention and amelioration, for emergency preparedness and response, and finally, for recovery. Communications are vital to prevent damages; to enable and coordinate timely emergency relief responses to protect the population, and to contain damages and losses in urban infrastructures. In this sense it is very important to understand ICTs' role during

all the stages of DRM programs. Table 3 describes some examples of ICT-based services to support DRM processes in cities.

**Table 3 – Examples of ICT use for DRM in cities**

Disaster phases	ICT services involved	Major tasks
DISASTER PREVENTION: <i>Prediction and detection</i>	<ul style="list-style-type: none"> <li>▪ Meteorological services (meteorological aids and meteorological-satellite service)</li> <li>▪ Earth exploration-satellite service</li> <li>▪ Geographic Information Systems (GIS)</li> <li>▪ Blogging, web 2.0 &amp; social networking</li> </ul>	<ul style="list-style-type: none"> <li>▪ Weather and climate prediction</li> <li>▪ Detection and tracking of hurricanes, typhoons, forest fires, among others</li> <li>▪ Providing warning information</li> </ul>
EMERGENCY PREPAREDNESS & RESPONSE: <i>Alerting</i>	<ul style="list-style-type: none"> <li>▪ Amateur services</li> <li>▪ Broadcasting services terrestrial and satellite (radio, television, etc.)</li> <li>▪ Fixed services terrestrial and satellite</li> <li>▪ Mobile services (land, satellite, maritime services, etc.)</li> <li>▪ Blogging, web 2.0 and social networking</li> </ul>	<ul style="list-style-type: none"> <li>▪ Receiving and distributing alert messages</li> <li>▪ Disseminating alert messages and advice to large sections of the public</li> <li>▪ Delivering alert messages and instructions to telecommunication centers for further dissemination to public</li> <li>▪ Distributing alert messages and advice to individuals</li> </ul>
RECOVERY: <i>Relief</i>	<ul style="list-style-type: none"> <li>▪ Amateur services</li> <li>▪ Broadcasting services terrestrial and satellite (radio, television, etc.)</li> <li>▪ Earth exploration-satellite services</li> <li>▪ Fixed services terrestrial and satellite</li> <li>▪ Mobile services (land, satellite, maritime services, etc.)</li> <li>▪ Blogging, web 2.0 and social networking</li> </ul>	<ul style="list-style-type: none"> <li>▪ Assisting in organizing relief operations in areas (especially when other services are still not operational)</li> <li>▪ Coordination of relief activities by disseminating information from relief planning teams to population</li> <li>▪ Assessment of damage and providing information for planning relief activities</li> <li>▪ Exchange of information between different teams/groups for planning and coordination relief activities</li> <li>▪ Exchange of information between individuals and/or groups of people involved in relief activities</li> </ul>

Source: Adapted from ITU-R (2013) and LIRNEasia (2008)

ICT tools enable information dissemination and analysis. They help to manage, analyze and disseminate geographic information that can be used for contingency planning, disaster assessment and post-disaster response (Box 4). ICTs also support climate modeling research, and provide new opportunities for policy makers and urban planners to understand cities and to project future scenarios.

**Box 4. Disaster Early Warning Network (DEWN)**

The Disaster Early Warning Network (DEWN) was launched in Sri Lanka on 30th January 2009. It aims to provide timely, reliable and cost-effective mass-scale disaster early warnings. DEWN represents a multipartite effort and a case of public-private partnerships in delivering ICT-based early warnings. DEWN's alerts are multi-modal; It makes use of multiple technologies to disseminate information to the last mile. The end devices are normal cellular phones and alarm devices which were specially developed for this initiative. DEWN can generate mass, personnel- directed or location-based alerts to the end devices using the two commonly-available mobile communication technologies: cell broadcast (CB) and short message service (SMS).

The DEWN server is located in Sri Lanka's Disaster Management Centre (DMC), the responsible agency on the island for all disaster management issues. The DMC receives early warning information from recognized technical agencies. Accordingly, information regarding floods, landslides, earthquakes and tsunamis is provided by the Irrigation Department, National Building Research Organization, Geological Survey and Mines Bureau, and Meteorological Department, respectively. The DMC holds the responsibility for verifying the emergency situation and then issuing alerts. Emergency personnel are alerted first in the case of a potential disaster and public alerts are issued after the threat is further verified (DMC 2009).

Source: Wickramasinghe, K (2011) " Role of ICTs in early warning of climate-related disasters: A Sri Lankan case study" [http://www.niccd.org/sites/default/files/NICCD\\_Disasters\\_Case\\_Study\\_EarlyWarning.pdf](http://www.niccd.org/sites/default/files/NICCD_Disasters_Case_Study_EarlyWarning.pdf)

During the disaster prevention phase, the use of ICTs such as Geographic Information Systems (GIS) in local hazard mapping and analysis can help to identify and illustrate evacuation routes as well as to locate housing, business and structures that are at risk of threats including rises in water levels (NICCD, 2011).

When a disaster occurs or an emergency situation takes place, technical standards facilitate the use of public telecommunication services and systems for communications during emergency and disaster relief operations. This capability, referred to as the "emergency telecommunication service", enables authorized users to organize and coordinate disaster relief operations as well as have preferential treatment for their communications via public telecommunication networks. This preferential treatment is essential as public telecommunication networks often sustain infrastructure damage which, coupled with high traffic demands, tends to result in severe congestion or overload to the system. In such circumstances, technical features need to be in place to ensure that users who must communicate during emergencies have the communication channels that they need, along with appropriate security and the best possible quality of service.

To ensure reliable universal access to communication in extreme weather events, the Common Alerting Protocol (CAP) developed by ITU provides a general format for exchanging all-hazard emergency alerts and public warnings over a range of networks. CAP allows a consistent warning message to be disseminated simultaneously over many different warning systems, thus increasing the warning's effectiveness and simplifying the warning task.

ITU also approved Recommendation ITU-T E.164 which assigns the country code 888 to the United Nations Office for the Coordination of Humanitarian Affairs (OCHA). This number is used by terminals involved in disaster relief activities in areas that have been cut off or disconnected from the national telecommunications system.



ICT tools help managing, analysing and disseminating geographic information that can be used for contingency planning, disaster assessment and post-disaster response (Box 5). Climate modelling research supported by ICT tools allows the mapping the different levels of vulnerability in cities. This provides a new opportunity for policy makers and urban planners to better understand cities and to project future scenarios.

#### **Box 5. Virtual centre on climate change**

The Mexico City Government has identified a number of strategic adaptive actions that need to be taken to react to these climatic changes (GDF 2008). Short-term, extreme event- related actions include: implementation of a metropolitan hydro-meteorological monitoring and forecasting system; micro-basin management of urban ravines; assistance to people who are identified as specifically vulnerable to extreme climate events; epidemiological monitoring; protection and recovery of native crops; and remote detection and monitoring of forest fires during the dry season. Actions for a medium- term response – which also encompass actions on mitigation of emissions – include: growth and improvement of public transportation and the transformation of vehicle technology; the efficient use of energy in buildings, industrial facilities, public lighting systems, water pumping systems, and homes; the exploitation of renewable energy sources; the rational use of water, as well as the reduction of waste generation and the promotion of an effective waste management system. However, such strategic actions require a sound evidence base, and also the opportunities for discussion among relevant stakeholders. In order to support this, in 2008, a Virtual Centre on Climate Change was created (Centro Virtual de Cambio Climático de la Ciudad de México – CVCCCM). The rationale for the Centre was that it would provide not just evidence and advice to policy-makers, but also help inform broader society – always enabled by ICT-based networks and other digital tools.

Source: Marino, O (2011) Building the evidence base for strategic action on climate change: Mexico City's virtual climate change centre. [http://www.niccd.org/sites/default/files/NICCD\\_Strategy\\_Case\\_Study\\_MexicoCentre.pdf](http://www.niccd.org/sites/default/files/NICCD_Strategy_Case_Study_MexicoCentre.pdf)

In summary, ICTs are effective tools for hazard mapping and environmental monitoring in cities. ICT can aggregate, create, and integrate data, delivering a comprehensive set of information, appropriate for each end user. Real-time information on the changing climate can support risk assessments, strengthen early warning systems (EWS) and enhance disaster preparedness.

### **3.2 ICTs for city resilience and adaptive capacity**

City resilience can be achieved in two ways: (i) by making urban ICT systems more robust and by (ii) increasing the city's adaptive capacity. A robust system is "*designed with safety margins that allow residents to survive sudden change and to quickly bounce back*". It is important to mention that the social, economic and physical elements of a city; including ICTs, can become more robust.

Adaptive capacity refers to the ability to respond to change and surprise, to quickly learn and easily adapt to new conditions without any major costs or permanent loss in function. ICT tools capture, transmit and disseminate data on climate and whether conditions, providing useful information on the environment for policy makers for the elaboration of adaptive responses. ICTs provide information dissemination and opportunities for urban planners to assess risks and work with future scenarios, thus contributing to the city's adaptive capacity, including its ability to design and implement both preventive and reactive measures (Box 6).



**Box 6. ClimSAT**

In 2008 a partnership between the regional government of Brittany and UNDP, established a climate science and technology hub in Brest, France: ClimSAT. It was initiated with the primary aim of improving access to information on the impacts of climate change for some of the most vulnerable areas in the developing world.

Satellite-based technology was used to enable governments and communities to monitor and model the effects of climate change, and to base climate change and development strategies on accurate, location-specific information. ClimSAT in its original form ceased operation in mid-2011 but was integrated into a wider UNEP programme, the Territorial Approach to Global Change, Scientific Services and Knowledge (TASK).

Source: Anderton K. (2011) Improving access to mapping, modelling and scenario-building technology in climate-vulnerable regions: Learning from ClimSAT.

[http://www.niccd.org/sites/default/files/NICCD\\_Monitoring\\_Case\\_Study\\_ClimSATModelling.pdf](http://www.niccd.org/sites/default/files/NICCD_Monitoring_Case_Study_ClimSATModelling.pdf)

These preventive measures also apply to the ICTs sector itself, as disasters can also affect existent ICT infrastructure, including smart sustainable cities structures such as smart buildings, smart grids or smart transport systems. It is critical to ensure that any form and means of communication (e.g., broadcasting radio receivers, Internet, mobile phones) and network infrastructure are not compromised by a disaster. Recovery and resilience of telecommunication network infrastructure are also important factors in ensuring efficient adaptive responses (Box 7). During the rehabilitation of affected infrastructure after an event, it is recommended that this opportunity is taken to include adaptation measures in the renovated ICT infrastructure. This could lead to cost reduction and to the earlier implementation of adaptive measures in order to be prepared for future events.

### Box 7. Telecom network risks management

During the rainy season in Lima, Perú, some mobile sites from the Telecom Operator Telefónica, are exposed to flooding risks. In case of weather alerts, the operations team of the company implements actions to prevent and avoid the damages to the facilities and infrastructure. For this potential risk, they have defined a specific fixed and mobile operator integrated procedure that defines the action plan to emergency cases. This document describes the action plan for all operational areas that have responsibility for the operation and maintenance activities of the network infrastructure. The procedure also describes the methodology for communications and notifications to apply in case of emergency, and the operational details for each step of an emergency plan. Telefónica Perú has also taken preventive steps to protect the network sites. The total cost of these preventive actions was extremely low in comparison to the potential damage of the equipment and network failure. The solution consisted of locking the doors of network sites with sandbags located in both sides of the door (inside and outside the room), as shown in the pictures below:



Source: Telefónica S.A and ITU (2013). "Resilient pathways: the adaptation of the ICT sector to climate change" [http://www.itu.int/en/ITU-T/climatechange/Documents/Publications/Resilient\\_Pathways-E.PDF](http://www.itu.int/en/ITU-T/climatechange/Documents/Publications/Resilient_Pathways-E.PDF)

The need for improving the resilience of telecommunication infrastructure in cities when a disaster occurs has been stressed in a study commissioned by ITU, *Resilient Pathways: The adaptation of the ICT sector to climate change* (ITU, 2014). This study responds to the need of exploring further the effects of climate change on the ICT sector, and aims at raising awareness of the need to design and implement strategies for the ICT sector to better cope with a disaster in cities context. Additional examples of initiatives to increase the resilience in the telecommunications sector at the city-level are provided in Box 8.

**Box 8. Initiatives for increasing resiliency in the telecommunications system in New York City, USA**

The New York City developed a comprehensive plan entitled "A stronger, more resilient New York" containing recommendations both rebuilding the communities impacted by Sandy and increasing the resilience of infrastructure and buildings citywide. The plan contains the following initiatives designed to mitigate the impact of climate change on New York's telecommunications system:

- Establishing an office within The New York City Department of Information Technology and Telecommunications (DoITT) to focus on telecommunications regulation and resiliency planning;
- Establishing new resiliency requirements for providers using scheduled renewals of the City's franchise agreements;
- Requesting business continuity plans from current city franchisees as permitted under existing franchise agreements;
- Developing flood protection standards for placement of telecommunications equipment in buildings;
- Using the DoITT franchise agreements to ensure hardening of all critical facilities;
- Studying options to increase conduit infrastructure redundancy and resiliency;
- Continuing the implementation of Connect NYC Fiber Access to create broadband redundancy;
- Adding telecommunications provider quality and resiliency to the WiredNYC and NYC Broadband map ratings.

A progress report of the implementation of the plan emphasizes that a robust telecommunications network is the backbone to New York City, supporting every aspect of work and life. That communication is especially critical during disasters or citywide catastrophes, during which the city is most vulnerable. The report indicates achievements under the telecommunications system, including a process for establishing the Telecommunications Planning and Resiliency Office (TPRO) to address telecommunication policy and enforcement issues in the event of future storms and disruptions like Sandy, a review of all of the city's existing franchise agreements and procurement contracts to identify opportunities for enhancing telecommunications resiliency.

Sources: The City of New York, 2013. A stronger, more resilient New York.

<http://www.nyc.gov/html/sirr/html/report/report.shtml>

The City of New York, 2014. Progress report: Sustainability & resiliency 2014.

[http://www.nyc.gov/html/planyc/downloads/pdf/140422\\_PlaNYCP-Report\\_FINAL\\_Web.pdf](http://www.nyc.gov/html/planyc/downloads/pdf/140422_PlaNYCP-Report_FINAL_Web.pdf)

Observing and understanding atmospheric processes and impacts in cities is essential to prepare a sustainable response, and to build urban resilience to climate change. ICT tools and services are a key resource in facilitating environmental data collection and analysis that can be used by city planners to improve urban preparedness to natural hazards and changing climatic conditions. Thus, ICTs (including radio, satellites, radar, earth observation systems) are valuable tools for environmental and climate change monitoring systems that can save thousands of lives.

Remote monitoring and data collection using ICT-equipped sensors (telemetry) is essential for climate change-related research. ICTs have also proved invaluable to conduct climate modelling experiments. The development of aerial photography, satellite imagery, grid technology and in particular the use of global positioning by satellite (GPS) for tracking slow and long-term movement, represent significant results of the use of ICTs that can support the development of climate change adaptation projects on a city level. (Box 9).

**Box 9. Real-time monitoring for responding to saline intrusion in Can Tho, Vietnam**

Can Tho is the fourth largest city in Vietnam in the Mekong Delta, crossed by canals and waterways that are the primary source of water in the city. The municipal water supply is drawn from this surface water to meet the different demands of the city: domestic uses by the city dwellers, irrigation and other uses by farmers. Historically unaffected due to its distance from the sea, saline intrusion has begun to influence river water in Can Tho city in recent years due to multiple climate change related factors include sea level rise, increased droughts, and increasing temperatures. Recent detection of inland salinity suggests that the city's surface water system is threatened by saline water intrusion as a result of sea level rise and changing Mekong river flow. This affects the livelihoods and health of the city's population, in particular the vulnerable poor.

To address this challenge, the Institute for social and environmental transition Vietnam, the Center for natural resources and environment monitoring (CENRM) of Can Tho City, and the Can Tho climate change coordination office, among other institutions, have partnered in developing a project to enhance Can Tho's resilience to the salinization of surface water resource. The project, includes real-time network of salinity monitoring stations linked to public warning systems via salinity maps published on public website, SMS alert system, and news on local media. The salinity monitoring system has an automatic system to record and publish real-time salinity data in the Mekong delta. The information is accessible to a wide group of stakeholders so that people's health and livelihoods, especially of the poor and vulnerable, are less afflicted. In addition, the project included development of an alert with radio, television, and text messages systems. The project is anticipated to directly benefit 300,000 to 400,000 people currently without information on salinity and the poor who are most vulnerable when water salinity levels rise.

Source: Asian Cities Climate Change Resilience Network (ACCCRN)

<http://www.acccrn.org/initiatives/vietnam/can-tho/city-projects/developing-and-implementing-real-time-salinity-monitoring>

The technology of Ubiquitous Sensor Networks (USN) is also proving useful in the field of environmental monitoring. USNs combine a network of sensors with computer processing power for data collection and analysis. All these systems form the Global Observing System (GOS). GOS is the primary source of technical information on the world's atmosphere, and is a composite system of complex methods, techniques and facilities for measuring meteorological and environmental parameters. WMO and ITU, together with other UN agencies, administrations and organizations, are contributing to further develop such systems.

An additional example of the use of ICTs in the field of environmental monitoring is included in Box 10.

### **Box 10. Sustainable urban development planner for climate change adaptation; the case of Wuppertal, Germany**

Sustainable Urban Development Planner for Climate Change Adaptation (Sudpna) is a European Union project that was implemented from 2010 to 2012 to assist cities in developing a web-based planning, prediction and training tool to support decisions in long term urban planning. Wuppertal was selected as one of the pilot cities.

Wuppertal located in the steep, narrow, long valley of the Wupper River. The main concern regarding climate change impacts is uncontrollable, extremely localized run-off from increased heavy, short rainfall events. The city copes with run-off from 350 kilometers of creeks (over 800 creek sections) and 650 kilometers of drainage channel system.

By expanding the possibilities for risk assessment using among others a 3D topography model, and a scenario management system SUDPLAN was applied to decision making on building measures. The models used in the pilot city of Wuppertal simulate the surface drainage during a heavy rain event, allowing the influence of climate change on the frequency and intensity of future rainfall to be studied. This created a basis for the approval process with affected decision makers and for advising affected individuals. It is a case study that illuminates integration of climate change in an actual, long-term urban planning process that also enhances public awareness for future risks.

Sources:

City of Wuppertal- official website: <https://www.wuppertal.de/pressearchiv/meldungen-2012/oktober/102370100000448723.php>

German Federal Environment Agency website: <http://www.umweltbundesamt.de/en/themen/klima-energie/klimafolgen-anpassung/werkzeuge-der-anpassung/tatenbank/anpassungsstrategie-der-wuppertaler>

Michel, F., Steffen, D., Schlobinski, S. and Sander, S., 2012 "Considering the Impact of Future Climate Change on the Resilience of a City - Surface Run-Off due to Heavy Storm Events in the City of Wuppertal"

Strategic sectors for the cities' economy can also be impacted by climate change, including the agricultural sector. Heat waves, droughts, or flooding associated with rising sea levels can lead to increased losses in land, agriculture and infrastructure, if unaddressed. ICTs can support city adaptation planning processes in order to strengthen agricultural practices. (Box 11).

**Box 11. ICTs for climate change adaptation in agricultural sector, Japan**

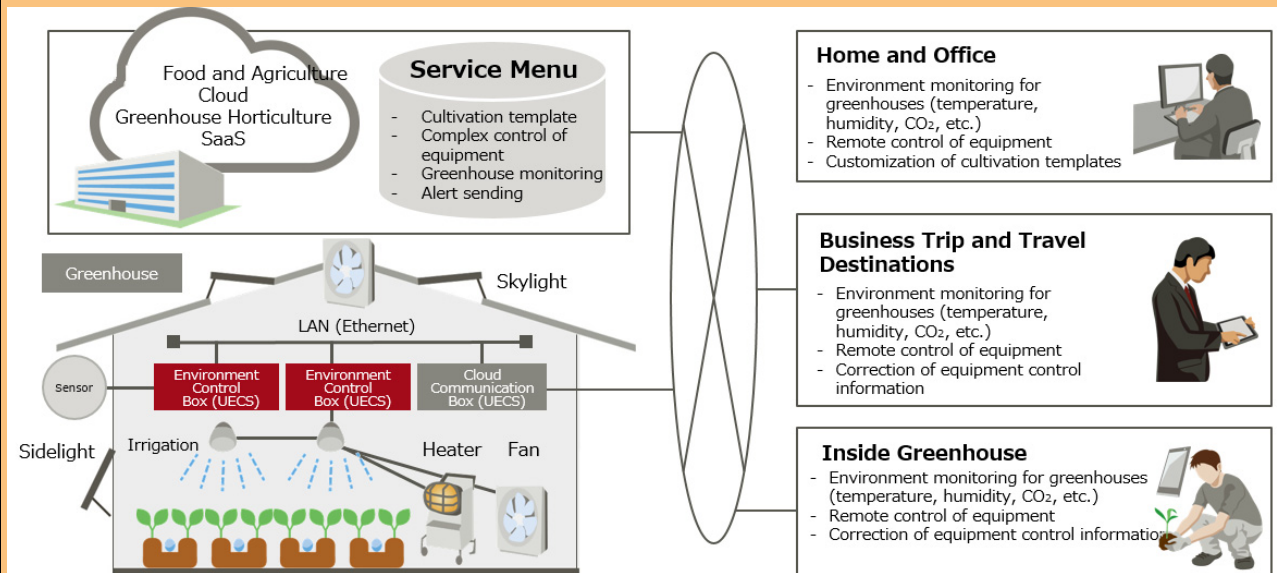
ICT can provide support in making informed decisions and production management of farmers with sensing network, cameras and cloud service. They can measure, accumulate and analyse environmental information such as temperature, humidity, quality of soil, solar insolation and amount of rainfall of the field. They can also enable automatic optimization of environmental conditions in a greenhouse or informed decision of farmers for best timing of harvesting and prevention of epidemic of diseases on fields.

**Examples of functions in a greenhouse controlled by ICT and related climate events**



Miyagi Prefecture, Japan, installed a system which is capable of finely controlling greenhouse temperatures, humidity, sunlight, and other growing conditions by measuring and accumulating such data in a cloud to improve production stability and efficiency (See below). This system employs the Ubiquitous Environment Control System (UECS) information standard for plant cultivation. UESC enables the use of a smartphone and other devices to remotely manipulate devices and equipment for controlling temperature, levels of sunlight, and other environmental conditions. This system is chosen in terms of low implementation cost, ease of installation and low maintenance.

**Image of greenhouse environment control by sensors and cloud**



Source: Fujitsu <http://jp.fujitsu.com/solutions/cloud/agri/uecs/>



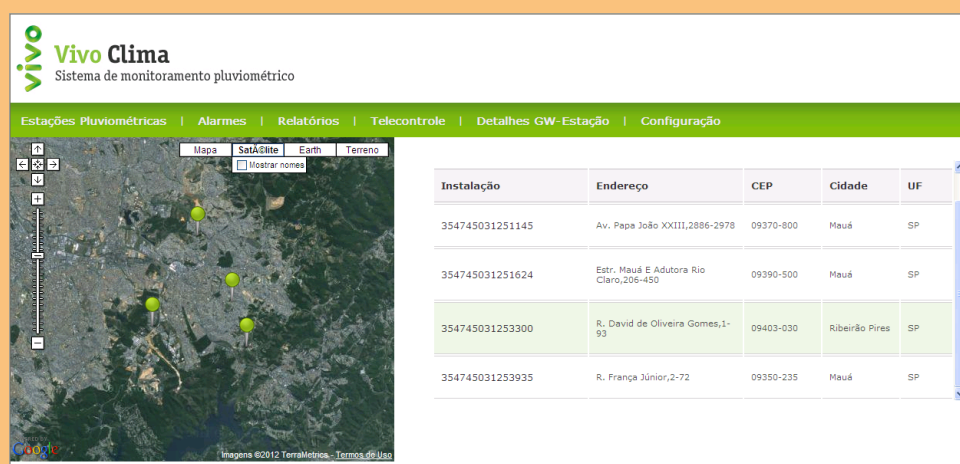
### 3.3 ICTs for informed adaptation decision making

According to the UNFCCC, effective engagement of stakeholders and management of knowledge for adaptation is vital in supporting all adaptation activities. Under the Cancun Adaptation Framework (2010), relevant multilateral, international, regional and national organizations, the public and private sectors, civil society and other relevant stakeholders are invited to undertake and support enhanced action on adaptation at all levels.

In addition to monitoring the environment and the changing climate, ICTs have a role to play in cities' climate change adaptation decision making by facilitating information dissemination. ICTs facilitate the inclusion of multiple voices in the design and implementation of adaptation strategies. ICT tools should be used to identify climate change related needs and priorities at city level, and support the identification of resources and capacities available to respond to climatic opportunities and threats. The availability of information provided through hazard mapping and monitoring, urban risk reduction in format that are easily understood by all levels of stakeholders, could motivate all urban dwellers to engage in joint climate change responses (Box 12).

#### Box 12. Maua town, city of Sao Pablo, VIVO-Clima Precipitation Public Information

This solution consists on a service that provides real-time information on precipitation levels in different geographic areas in the Maua town in the city of Sao Paulo. VIVO-Clima runs from the installation of rain gauges in the mobile phone sites of Telefónica Brazil, which send information to the company m2m management platform. The system focuses primarily on trying to prevent natural disasters such as floods, landslides and droughts in climate risk areas. This initiative gathers information in real time and promotes rainfall forecast more effective, enabling better protection of people living in areas at risk. The information gathered, is displayed in a web-based platform that can be accessed via Internet by the public and the government.



Source: Telefónica S.A & ITU Report resilient pathways: The adaptation of the ICT sector to climate change (2013). [http://www.itu.int/en/ITU-T/climatechange/Documents/Publications/Resilient\\_Pathways-E.PDF](http://www.itu.int/en/ITU-T/climatechange/Documents/Publications/Resilient_Pathways-E.PDF)

ICTs can also help raise public awareness on health-related problems that are intensified by climate change manifestations (e.g., malaria), supporting EWS to disseminate information in order to prevent or control the spread of diseases. Similarly, they can support public awareness and education campaigns on safe-housing construction, water storage and robust drainage systems, empowering the community to mitigate the impacts of climatic occurrences.

New and traditional ICTs (e.g., mobile phones, community radios) can also be used as effective information and EWS among populations settled in dangerous terrains. Policy and research

networks can be supported by social media tools to discuss and give visibility to climate-related agendas that respond to the needs and priorities of low-income urban populations.

ICTs used in support of social networking can also improve the capacity of low-income urban communities to respond effectively in the case of climate-induced emergencies, as well as to access information about markets, employment opportunities and livelihood alternatives. Tools such as online training, blogging or web 2.0 tools; can contribute to disseminate knowledge and strengthen capacity of the experts involved in the process of resilience building and disaster risk management programs. As suggested by the Nexus on ICTs, climate change and development initiative (NICCD, 2011),

*"Social media tools can also support public awareness and education campaigns, as well as foster participative processes. ICT applications such as participatory videos, photo-diaries or the use of mobile phones for collective mapping/monitoring exercises, could be used to foster greater involvement of low-income urban dwellers in climate change and risk-reduction initiatives, involving them in decisions such as the best location for drinking water supplies in case of sudden salinization, or failures in drainage systems due to floods."*

ICTs can also be applied to facilitate communication and exchange between local governments, communities, grass-roots organisations and researchers working in urban development programmes, strengthening transparency, accountability and public support (Box 13).

#### **Box 13. Social media for rising temperature adaptation in Eldoret, Kenya.**

The local community of Rift Valley in the Kenyan city of Eldoret, have been working to raise public awareness about climate change and how to adapt to rising temperatures in the region. They educated themselves by attending workshops and conferences organized by environmental organizations. The group has more than 900 followers on Facebook, who access the information shared on the site and have online discussions about farming. Use of social media networks among young Kenyans is growing rapidly. Most use them for socializing, however YVE views them as a means to reach young farmers. Recent changes in weather patterns have affected cereal farmers in parts of the Rift Valley, and planting maize every year is an increasing challenge because of irregular rainfall, as well as outbreaks of pest-borne diseases such as maize lethal necrosis. Farmers need of good information about changing weather patterns and ICT tools: Facebook and mobile SMS have been very useful for them.

Source: Kemboi, C. (2013) Young farmers turn to social media to adapt to climate change. <http://www.trust.org/item/20130716085920-k63xg/?source=spotlight>

ICTs can help strengthen the capacity of institutions involved in processes of climate change adaptation, improving the availability of resources and skills needed for effective adaptation. For example, online training programs and access to broader networks of practitioners and experts to share lessons and resources could help to strengthening the institutional capacity of those involved in processes of urban planning and design.

It is important to acknowledge that, through their role in the three categories mentioned above (i.e., enhanced disaster risk management, city resilience and adaptive capacity, and informed decision making), ICTs are also contributing to facilitate the integration of climate change adaptation into broader national development planning processes, which constitutes a key goal of adaptation strategies. The examples included in Table 4 reflect the potential role of ICTs towards this end:

**Table 4 – ICTs contribution to the integration of adaptation into development strategies**

ICT categories	Integration of adaptation into development strategies
(a) ICTs for enhanced disaster risk management	ICTs can help to strengthen vulnerability and risk assessments in susceptible locations in the city (e.g., through the use of GIS and modeling techniques), as well as to improve indicators and data collection.
(b) ICTs to improve city resilience and adaptive capacity	ICTs can help to gather city-specific evidence on adaptation practices (e.g., using satellite and mobile-based applications) and to highlight their impact on vulnerability reduction.
(c) ICT-based adaptation informed decision making	ICTs can help to strengthen institutional and capacity development (e.g., through online training, improved knowledge access) to inform the implementation of sectoral and local programmes.

## 4 Framework for ICTs' integration in cities climate change adaptation plans

After the identification of the role that ICTs can play in the development of cities adaptation initiatives, it is important to provide a framework to foster the inclusion of ICTs into cities climate change adaptation policies and plans.

As mentioned in section 2, according to the UNFCCC, the key elements for an urban adaptation process include: 1) laying the groundwork & addressing gaps; 2) preparatory elements; 3) implementation strategies and 4) reporting monitoring and review. Within this framework, the first step to integrating ICTs into urban adaptation processes entails merging the specific ICTs roles identified before (section 3) during the conceptualization of climate change adaptation plans. This framework should be built upon several components, which may include: a transectoral vision of urban adaptation planning, an assessment of climate change risks and vulnerabilities in cities, pointing out the key role of ICT and a cross-sectoral adaptation policy process. Recognizing the benefits of ICTs for climate change adaptation in cities will facilitate the integration of ICT tools and services in support to their policies.

The framework for ICTs' integration for cities adaptation planning should follow "*the one step at the time approach*". The steps have been established based on the suggested policy cycle suggested by the UNFCCC steps for climate adaptation, described as follows. In this sense, the proposed framework for integrating ICTs into cities can have the following steps.

- 1) **Setting the basis: Observation and understanding:** city planners should consider the role of ICTs in climate change adaptation as a new alternative in their local adaptation plans. They should take stock of existing measures, opportunities and challenges on the integration of ICTs in climate change adaptation.
- 2) **Assessing climate change risks and vulnerabilities:** this should involve an assessment of how ICTs can support cities during this step to identify adaptation options, as well as to carry out an assessment of the specific risks and vulnerabilities on ICT infrastructure.
- 3) **Planning of adaptation options:** during this step is important to define the role of ICTs in identifying adaptation options for cities, as well as those options that would ICTs adaptation from the impacts of climate change. Once the potential adaptation options are identified, an assessment should be carried out to determine which of them suit the cities specific context. The approach consists on prioritizing those ICTs that would best support adaptation options in a given city context, including the evaluation of social, environmental and economic variables. This step also involves the prioritization of adaptation options for the ICT infrastructure.
- 4) **Implementation of adaptation actions:** this step relates to the development of an implementation plan to convert adaptation options into actions. It involves the integration of ICTs in the design of implementation strategies for identified/prioritized adaptation options, together with the implementation of specific adaptation options for the ICT infrastructure.
- 5) **Monitoring and evaluating adaptation actions:** this step consists on a monitoring system and evaluation of the role on ICTs in climate change adaptation, in order to ensure the focus and effectiveness of adaptive actions. ICTs can support this process, for example through software tools to enable modelling, monitoring and analysis of climate change impact in cities.

This Technical Report strongly encourages the collaboration of all stakeholders involved in the implementation of adaptation strategies at city level. The collaboration among cities can also contribute to the creation of platforms to share good practices and lessons learned. This requires the participation of all stakeholders, and the active involvement of the civil society. This wide set of stakeholders is explored in further detail in the following sub-section.

#### 4.1 Engaging stakeholders for the integration of ICTs in climate change adaptation plans in cities

Cities in their journey to become smart and sustainable could be the first responders to the effects of climate change and the use of ICTs to improve their climate change adaptation policies and strategies. Cities are complex systems where a variety of stakeholder coexist. Key stakeholders range from local government to civil society and business, international organizations, ICT Industry, non-governmental organizations and citizens, among others. They span across multiple disciplines and areas of expertise.

In such complex systems, collaboration between stakeholders is needed to develop urban resilience strategies including ICTs. It is hence crucial to identify the players relevant to issues of climate change adaptation in cities in order to strengthen coherent adaptive response capability.

The Technical Report on "Setting the stage for stakeholders' engagement in smart sustainable cities", developed by the ITU Focus Group on SSC, suggests that cities in the process of becoming smart and sustainable must identify all the stakeholders that could contribute to achieve cities goals.

This proposal includes three stages. First the identification of all stakeholders involved, secondly the categorization of the listed stakeholders; and finally the development of a detailed analysis of selected stakeholders. This view could be applicable too in the process of introducing ICTs in climate adaptation plans.

Urban actors are particularly vulnerable to the potential impacts of climate change can be identified as key stakeholders (CSIRO, 2009). Their vulnerability can be measured by taking into account the following parameters: exposure, sensitivity, potential impact and adaptive capacity to climate change. Their engagement in urban climate change adaptation strategies will ultimately depend on their level of vulnerability. Their role in urban climate change adaptation will vary based on the nature of each player's business, and on the city's specific needs (ALU, 2012).

According to these considerations, a non-exhaustive list of potentially relevant stakeholders can be identified as follows (CSIRO, 2009):

- **Citizens or specific communities:** these stakeholders are located in areas which are vulnerable on the basis of their location.
- **National and regional governments:** they are in charge of climate change adaptation policies on a country scope.
- **Infrastructure management agencies and utility providers:** they are responsible for the deployment of infrastructure and services that could be affected by climate change.
- **Associations and non-governmental organizations (NGOs):** these associations and NGOs are involved in all initiatives that can influence society and facilitate the use and introduction of ICTs in cities' adaptation policies.
- **ICT companies** (Telecom Operators, Start-ups, Software Companies): these companies are the providers of the global and integrated solutions for ICT services, including solutions for climate change adaptation in cities. In addition, they are responsible for the ICT infrastructure in the cities.
- **International, regional and multilateral organizations:** these include UN agencies and multilateral organizations. They may assert their authority as promoters of initiatives towards ICTs and climate change adaptation in cities.
- **Urban planners:** expertise provided by urban planners is important to better understand how to include ICTs into medium and long term city planning, as well as to consider urban complexities including present and future climate impacts and vulnerabilities in the city.
- **Academia, research organizations and specialized bodies:** these organizations and bodies can contribute in the process of including ICTs in adaptation policies, as they are familiar with innovative projects and environmental trends in cities.

These stakeholders will have a role to play in one (or multiple) of the following areas, according to their expertise and experience.

- **Urban planning:** to identify the areas of a city which are most likely to be affected by the effects of climate change;
- **Mobility:** to monitor the status of the urban transportation infrastructures and issue early alerts;
- **Infrastructures and construction** (including ICT infrastructure): to promote safe building practices in areas of high risks, to monitor the status of infrastructures and buildings and issue early alerts;
- **Energy:** to ensure continuing energy supply in emergency situations;

- Water supply and sanitation: to manage water resources and prevent scarcity of clean water;
- Health: to monitor diseases and issue early warning alerts;
- Waste management: to manage municipal waste and e-waste;
- Food security: to ensure food supply under climate stress;
- Disaster management: to provide prediction and detection, alerting and relief, and make recovery and resilience of city infrastructure, including telecommunication networks infrastructure;
- Environmental management: to ensure that environmental problems such as the degradation of ecosystem services are addressed.

Within this stakeholders' system, international organizations such as the United Nations agencies offer platforms and activities to enable countries to collaborate in order to find solutions to combat climate change. Governments lead the policy formulation process; they review, approve and harmonize climate change adaptation strategies. Business offers its services and technical expertise; NGOs and the civil society are involved in advocacy and raising awareness, contributing to share experiences and best practices on climate change adaptation; while academia provides the knowledge and expertise to advise policy makers.

## 5 Smart sustainable cities' adaptation checklist

---

In order to understand how ICTs can support climate change adaptation in smart sustainable cities (SSC), it is important to understand that cities face challenges to implement climate change adaptation policies as they are dynamic and complex interconnected systems. Adaptation to climate change requires the collaboration across all cities' sectors and will require investments and technology. This process involves both challenges and opportunities, as cities provide the optimal scenario to lead in the use of ICTs for climate change adaptation, due to its concentration of population and connectivity.

The ITU-T Study Group 5 and UNECE based on the ITU's Focus Group on Smart Sustainable Cities (FG-SSC) provided a comprehensive definition for smart sustainable cities, as follows:

*"A smart sustainable city is an innovative city that uses information and communication technologies (ICTs) and other means to improve quality of life, efficiency of urban operation and services, and competitiveness, while ensuring that it meets the needs of present and future generations with respect to economic, social, environmental as well as cultural aspects."*

Within this context it is important to understand that city policies and activities towards climate change adaptation should actively integrate the use of ICTs as a key component in their process towards becoming smart sustainable cities.

As mentioned before and illustrated through a number of examples, ICTs have a significant role to play in reinforcing the disaster prevention and in coordinating the information flow between multiple public agencies, businesses and civil society, among other key functions. On the one hand, ICT infrastructure and solutions embedded in cities can help move "practical steps to protect countries and communities from the likely disruption and damage that will result from effects of climate change" (UNFCCC, 2006) and boost resilience.



Having suggested a framework for city mayors to integrate ICTs in their climate change adaptations plans and help to build their cities' resilience, this section provides a checklist that can support the assessment of their ICT-enabled adaptation plans. This checklist can help mayors and municipal authorities to evaluate whether climate change adaptation actions were successful and if ICTs met their role of enablers in the process.

The proposed smart sustainable cities' adaptation checklist (Table 5) aims at providing practical guidance to city planners for assessing the integration of ICTs into their adaptation strategies. It can help city planners to evaluate the degree of inclusion of ICT tools and services in the strategic adaptive response, and assist them in improving adaptation strategies.

**Table 5 – Proposed smart sustainable cities' climate change adaptation checklist**

Key areas for the integration of ICTs into adaptation plans	Description
(a) Climate change adaptation planning	Integration of ICTs in cities' climate change adaptation planning based on benchmarking studies, or concrete examples already implemented in the city. (e.g., number of/ concrete examples of ICT applications or related services used for observation and understanding, climate risk and vulnerability assessment, planning of adaptation options, implementation of adaptation options, monitoring and evaluation of adaptation options).
(b) Institutional coordination	Participation of multiple actors that understand the enabling effect of ICTs in climate adaptation policies. Use of ICTs in the coordination of climate risk management among relevant institutions and SSC stakeholders (e.g., concrete examples of ICTs usage to enable communication between key players involved in adaptation actions).
(c) Institutional knowledge and capacity	Use of ICTs to enhance the level of knowledge and training of key personnel in climate change issues and mainstreaming processes (e.g., number of ICTs used to facilitate access to climate change information by city planners and experts; number of online training courses/resources used for institutional capacity building on climate change adaptation)
(d) Informed decision-making	Use of ICTs to inform institutional decision-making and to reduce climatic uncertainty (e.g., examples of ICT applications used to strengthen decision-making processes and to improve climate change forecasts)

**Table 5 – Proposed smart sustainable cities' climate change adaptation checklist**

Key areas for the integration of ICTs into adaptation plans	Description
(e) Stakeholder participation	Use of ICTs to foster participatory processes and improve stakeholder engagement in climate change adaptation decision-making (e.g., social networking tools used to broaden stakeholder participation in adaptation processes, number of ICT applications used to increase transparency and share citizen's voices as part of adaptation processes)
(f) Stakeholder awareness	Use of ICT tools to raise stakeholders' awareness about climate change issues, risks and responses options in the city (e.g., number of ICT applications used as part of public awareness/education campaigns on climate change issues)
(g) Vulnerability/resilience	Use of ICTs to strengthen the coping capacity of the city in face of climate change impacts, including increased livelihoods' resilience, more robust public utilities infrastructures (e.g., number of cases in which ICTs were used to improve the ability of different city sectors and services (e.g., transport, water, energy, health) to withstand and recover from climate-related disasters).

Source: adapted from IIED (2012) and report content.

## Conclusion

Climate change adaptation strategies can receive a fundamental boost if national, regional and local Governments choose to harness and utilize the transformational potential of ICTs. This paper recognizes that the potential impacts of climate change in cities could be significant. This is because cities contribute significantly to the national Gross Domestic Product (GDP), since economic activities is centred in and around them for every nation. Climate change may disrupt economic activities and services, damaging important sectors and services, including water supply and sanitation, agriculture, urban planning, mobility, building infrastructure, energy, health, waste management and food security.

This Technical Report identifies three enabling roles of ICTs for climate adaptation in cities. Firstly, utilizing ICTs for enhanced disaster risk management; secondly ICTs to improve city resilience and adaptive capacity and finally ICTs for informed adaptation decision making. For these three roles, this report provides detailed examples, drawing from a wide and prolific range of country and city experiences.

In order to guide countries in their overall adaptation planning and implementation, a national adaptation plan (NAP) process has been put in place under the UNFCCC. The NAP process allows countries to develop their adaptation activities in a coherent and strategic manner. Based on the NAP process, countries can reduce their vulnerability to the impacts of climate change and build adaptive capacity and resilience to climate change. This process also helps to facilitate the integration of climate change adaptation into the already existing development planning processes within all the sectors in a city.

In conclusion, this report gives a general overview of the enabling role of ICTs in climate change adaptation plans and policies. It aims at suggesting a guiding framework to support cities in the challenging process of adapting to climate change. In the interest of harmonization, the proposed framework and checklist could also serve as baseline for future standardization activities to be carried out within Question 15/5 of ITU-T Study Group 5.

This Technical Report also provides several case studies from developed and developing countries which would serve to encourage other countries to develop climate change adaptation plans along similar lines.

## Bibliography

- ALU, 2012. Getting Smart about Smart Cities Understanding the market opportunity in the cities of tomorrow. Retrieved on 08 January 2014 from <http://www.tmcnet.com/tmc/whitepapers/documents/whitepapers/2013/6764-getting-smart-smart-cities-market-analysis.pdf>
- Anderton K. (2011). Improving access to mapping, modeling and scenario-building technology in climate-vulnerable regions: Learning from ClimSAT. [http://www.niccd.org/sites/default/files/NICCD\\_Monitoring\\_Case\\_Study\\_ClimSATModelling.pdf](http://www.niccd.org/sites/default/files/NICCD_Monitoring_Case_Study_ClimSATModelling.pdf)
- Asian Cities Climate Change Resilience Network (ACCCRN), <http://www.acccrn.org/initiatives/vietnam/can-tho/city-projects/developing-and-implementing-real-time-salinity-monitoring->
- Bex and P.M. Midgley (eds.)), Cambridge University Press, Cambridge, United Kingdom and New York, NY, USA. [http://www.climatechange2013.org/images/report/WG1AR5\\_SPM\\_FINAL.pdf](http://www.climatechange2013.org/images/report/WG1AR5_SPM_FINAL.pdf)
- City of Wuppertal – official website: <https://www.wuppertal.de/pressearchiv/meldungen-2012/oktober/102370100000448723.php>
- CSIRO, 2009. A framework for stakeholder engagement on climate adaptation. Retrieved on 08 January 2014 from <http://www.csiro.au/Organisation-Structure/Flagships/Climate-Adaptation-Flagship/CAF-working-papers/CAF-working-paper-3.aspx>
- DCCS, 2014. Durban Climate Change Strategy 2014, Environmental Planning and Climate Protection Department (EPCPD) and the Energy Office (EO) of eThekweni Municipality. [http://www.dccs.org.za/wp-content/uploads/2014/09/DCCS\\_Final-Draft.pdf](http://www.dccs.org.za/wp-content/uploads/2014/09/DCCS_Final-Draft.pdf)
- European Agency of Environment (EEA), 2012 Urban adaptation to climate change in Europe Challenges and opportunities for cities together with supportive national and European policies. [http://orca.cf.ac.uk/64905/1/EEA-Report-2-2012\\_Urban\\_adaptation\\_to\\_climate\\_change.pdf](http://orca.cf.ac.uk/64905/1/EEA-Report-2-2012_Urban_adaptation_to_climate_change.pdf)
- Ecojesuit, 2011. Climate change and conflict. Retrieved on 18 December 2013 from <http://ecojesuit.com/climate-change-and-conflict/1619/>
- ETSI, 2012. Intelligent Transport System. Retrieved on 18 December 2013 from <http://www.etsi.org/technologies-clusters/technologies/intelligent-transport>
- EU, 2012. Intelligent transport system. Retrieved on 16 December 2013 from [http://ec.europa.eu/transport/themes/its/road/application\\_areas/ict\\_infrastructure\\_en.htm](http://ec.europa.eu/transport/themes/its/road/application_areas/ict_infrastructure_en.htm)
- German Federal Environment Agency website: <http://www.umweltbundesamt.de/en/themen/klima-energie/klimafolgen-anpassung/werkzeuge-dTableer-anpassung/tatenbank/anpassungsstrategie-der-wuppertaler>
- GLA 2011. Managing risks and increasing resilience: The Mayor's climate change adaptation strategy., Greater London Authority (GLA), <http://www.london.gov.uk/sites/default/files/Adaptation-oct11.pdf>
- GTZ, 2009. Adapting urban transport to climate change. Retrieved on 15 December 2013 from <http://www.sutp.org/component/phocadownload/category/53-5f?download>

- Hallegatte, S. and Corfee-Morlot, J., 2011. Understanding climate change impacts, vulnerability and adaptation at city scale. *Climate change*, 104:1-12
- Hanson, S., Nicholls, R., Ranger, N., Hallegatte, S., Corfee-Morlot, J., Herweijer, C. and Chateau, J., 2011. A global ranking of port cities with high exposure to climate extremes. *Climate change*, 104:89-111
- Hunt, A. and Watkiss, P., 2011. Climate change impacts and adaptation in cities: a review of the literature, *Climate Change*, 104: 13-49
- IBD, 2013. Vulnerability indicators of adaptation to climate change and policy implications for IDB projects. Retrieved on 16 December 2013 from <http://idbdocs.iadb.org/wsdocs/getdocument.aspx?docnum=37725582>
- IEA, 2013, International Energy Agency. Forum on the Climate-Energy Security Nexus: Electricity Sector Resilience <http://www.iea.org/workshop/thenexusforum-3rdforumontheclimate-energysecuritynexus/electricity.html>
- IIED, 2012. Tracking adaptation and measuring development. Retrieved on 17 December 2013 from <http://www.iied.org/tracking-adaptation-measuring-development>
- IPCC, 2007. The Regional Impacts of Climate Change. IPCC, 1997 - R.T.Watson, M.C.Zinyowera, R.H.Moss (Eds). <http://www.ipcc.ch/ipccreports/sres/regional/144.htm>
- IPCC, 2007. Contribution of Working Group II to the Fourth Assessment Report of the Intergovernmental Panel on Climate Change, M.L. Parry, O.F. Canziani, J.P. Palutikof, P.J. van der Linden and C.E. Hanson (eds). Cambridge University Press, Cambridge, United Kingdom and New York, NY, USA.
- IPCC, 2013. Summary for Policymakers. In: *Climate Change 2013: The Physical Science Basis. Contribution of Working Group I to the Fifth Assessment Report of the Intergovernmental Panel on Climate Change* [Stocker, T.F., D. Qin, G.-K. Plattner, M. Tignor, S. K. Allen, J. Boschung, A. Nauels, Y. Xia, V.
- IPCC, 2014. Summary for Policy Makers. In: *Climate Change 2014: Impacts, Adaptation, and Vulnerability. Contribution of Working Group II to the Fifth Assessment Report of the Intergovernmental Panel on Climate Change*. Field, C.B., V.R. Barros, D.J. Dokken, K.J. Mach, M.D. Mastrandrea, T.E. Bilir, M. Chatterjee, K.L. Ebi, Y.O. Estrada, R.C. Genova, B. Girma, E.S. Kissel, A.N. Levy, S. MacCracken, P.R. Mastrandrea, and L.L. White (eds.)). Cambridge University Press, Cambridge, United Kingdom and New York, NY, USA, pp. 1-32.
- ITU, 2009. ITU Symposium on ICTs and Climate Change. Retrieved on 10 December 2013 from. [http://www.itu.int/dms\\_pub/itu-t/oth/06/0F/T060F00600C0004PDFE.pdf](http://www.itu.int/dms_pub/itu-t/oth/06/0F/T060F00600C0004PDFE.pdf)
- ITU, 2012. Information and communication technologies (ICTs) and climate change adaptation and mitigation: The case of Ghana. [http://www.itu.int/dms\\_pub/itu-t/oth/4B/01/T4B010000020001PDFE.pdf](http://www.itu.int/dms_pub/itu-t/oth/4B/01/T4B010000020001PDFE.pdf)
- ITU, 2013. Focus Group on Disaster Relief Systems, Network Resilience and Recovery. Retrieved on 17 December 2013 from <http://www.itu.int/en/ITU-T/focusgroups/dnrr/Pages/default.aspx>
- ITU, 2014. Resilient Pathways: The adaptation of the ICT sector to climate change. [http://www.itu.int/en/ITU-T/climatechange/Documents/Publications/Resilient\\_Pathways-E.PDF](http://www.itu.int/en/ITU-T/climatechange/Documents/Publications/Resilient_Pathways-E.PDF)

- ITU, 2007. Common alerting protocol (CAP 1.1). Retrieved on December 2013 from <http://www.itu.int/ITU-T/recommendations/rec.aspx?rec=9115>
- Kemboi, C. Young farmers turn to social media to adapt to climate change. <http://www.trust.org/item/20130716085920-k63xg/?source=spotlight>
- LIRNEasia, 2008. Disaster Management and the role of ICTs. <http://fr.slideshare.net/ISCRAM/disaster-management-role-of-icts-presentation>
- Marino, O (2011) Building the evidence base for strategic action on climate change: Mexico City's virtual climate change centre. [http://www.niccd.org/sites/default/files/NICCD\\_Strategy\\_Case\\_Study\\_MexicoCentre.pdf](http://www.niccd.org/sites/default/files/NICCD_Strategy_Case_Study_MexicoCentre.pdf)
- Michel, F., Steffen, D., Schlobinski, S. and Sander, S., 2012 "Considering the Impact of Future Climate Change on the Resilience of a City - Surface Run-Off due to Heavy Storm Events in the City of Wuppertal"
- NICCD, 2011. The Urban Face of Climate Change Resilience: ICT Perspectives. Nexus on ICTs, climate change and development (NICCD). Retrieved on 15 December 2013 from <http://niccd.wordpress.com/2011/07/30/the-urban-face-of-climate-change-resilience-ict-perspectives/>
- OECD. 2007. "Ranking of the world's cities most exposed to coastal flooding today and in the future" <http://www.oecd.org/env/cc/39721444.pdf>
- Rosenzweig, C., and W. Solecki (Eds.), 2010: Climate Change Adaptation in New York City: Building a Risk Management Response. Report of the New York City Panel on Climate Change published as volume 1196 of Ann. New York Acad. Sci. Available at <http://onlinelibrary.wiley.com/doi/10.1111/j.1749-6632.2009.05306.x/pdf>.
- The City of New York, 2013. A Stronger, More Resilient New York. <http://www.nyc.gov/html/sirr/html/report/report.shtml>
- The City of New York, 2014. Progress report: Sustainability & Resiliency 2014. [http://www.nyc.gov/html/planyc/downloads/pdf/140422\\_PlaNYCP-Report\\_FINAL\\_Web.pdf](http://www.nyc.gov/html/planyc/downloads/pdf/140422_PlaNYCP-Report_FINAL_Web.pdf)
- United Nations (UN). 2011. Department of Public Information - News and Media Division. 'Make No Mistake', Says Secretary-General, 'Climate Change Not Only Exacerbates. Threats to Peace and Security, It Is a Threat to International Peace and Security. <http://www.un.org/press/en/2011/sc10332.doc.htm>
- UCAR, 2009. Investigating Urban Atmospheres: From Downtown to the Whole Planet. Retrieved on 18 December 2013 from <http://www.ucar.edu/news/features/urbanair/>
- UNDESA, 2010. World Urbanization Prospects: The 2009 Revision. Retrieved on 16 December 2013 from [http://esa.un.org/unpd/wup/Documents/WUP2009\\_Highlights\\_Final.pdf](http://esa.un.org/unpd/wup/Documents/WUP2009_Highlights_Final.pdf)
- UNPD, 2012. World Urbanization Prospects, the 2011 Revision. Department of Economic and Social Affairs, Population Division, United Nations, New York. Retrieved on 17 December 2013 from [http://esa.un.org/unup/pdf/WUP2011\\_Highlights.pdf](http://esa.un.org/unup/pdf/WUP2011_Highlights.pdf)
- UNFCCC, 2006. Adaptation to climate Change: Key terms. Retrieved on 8 January 2014 from <http://www.oecd.org/environment/climatechange/36736773.pdf>
- UNFCCC, 2010. Cancun Adaptation Framework. <http://unfccc.int/adaptation/items/5852.php>



UNFCCC 2014. National adaptation plans.

[http://unfccc.int/adaptation/workstreams/national\\_adaptation\\_plans/items/6057.php](http://unfccc.int/adaptation/workstreams/national_adaptation_plans/items/6057.php)

UNFCCC, 2012. Technical Paper on Slow onset events. Retrieved on 5 June 2014

<http://unfccc.int/resource/docs/2012/tp/07.pdf>

UNHABITAT, 2009. Cities and climate change: an introduction. Retrieved on 8 January 2014 from

[www.unhabitat.org/pmss/getElectronicVersion.asp?nr=2958&alt=1](http://www.unhabitat.org/pmss/getElectronicVersion.asp?nr=2958&alt=1)

UN-HABITAT, 2014. Cities and Climate Change Initiative.

<http://unhabitat.org/urban-initiatives/cities-and-climate-change-initiative/>

UN-HABITAT, 2014. Hoi An, Viet Nam: Climate Change Vulnerability Assessment.

<http://unhabitat.org/publications/hoi-an-viet-nam-climate-change-vulnerability-assessment/>

Wickramasinghe, K (2011) "Role of ICTs in early warning of climate-related disasters: A Sri Lankan case study"

[http://www.niccd.org/sites/default/files/NICCD\\_Disasters\\_Case\\_Study\\_EarlyWarning.pdf](http://www.niccd.org/sites/default/files/NICCD_Disasters_Case_Study_EarlyWarning.pdf)

World Bank, 2011. Guide to climate change adaptation in cities. Retrieved on 22 November 2013

<http://web.worldbank.org/WBSITE/EXTERNAL/TOPICS/EXTURBANDEVELOPMENT/0,,contentMDK:23026256~menuPK:337198~pagePK:148956~piPK:216618~theSitePK:337178~isCURL:Y,00.html>

WHO, World Health Organization. Fact Sheet, 266 on Climate Change and Health. 2014.

<http://www.who.int/mediacentre/factsheets/fs266/en/>

WWF, 2012. Living planet report. Retrieved on 17 December 2013 from

[http://awsassets.panda.org/downloads/1\\_lpr\\_2012\\_online\\_full\\_size\\_single\\_pages\\_final\\_120516.pdf](http://awsassets.panda.org/downloads/1_lpr_2012_online_full_size_single_pages_final_120516.pdf)









# 3.8

## Electromagnetic field (EMF) considerations in smart sustainable cities

## Acknowledgements

This Technical Report was researched and principally authored by Mike Wood (Telstra) and Jack Rowley (GSMA) with oversight and contributions from Gilbert Buty and Christophe Grangeat (Alcatel-Lucent); Hector Carril (Secretaría de Comunicaciones de la Nación, Argentina); Pablo Bilbao (Argentine Federation of Municipalities - FAM); Josette Gallant and Hughes Nappert (Industry Canada); Brian Copsey (Copsey Communications); Davide Colombi and Christer Törnevik (Ericsson); Haim Mazar (Ministry of Communications, Israel); ITU-R Study Group Spectrum Management; Jafar Keshvari (Microsoft); Ken Joyner and Michael Milligan (Mobile Manufacturers Forum); Mitsuo Hattori (NTT and ITU-T Study Group 5 Working Party 2/5 Chairman); Joe Wiart (Orange Group); Fryderyk Lewicki (Orange Polska); Tariq Alamri (Communications and Information Technology Commission, Saudi Arabia); Flavio Cucchiatti (Telecom Italia); Brendon Woods Consulting (Australia), Dr Phil Knipe (TRS), Angelica Ospina (University of Manchester) and Ziqin Sang (Wuhan Research Institute of Posts and Telecommunications).

The authors also acknowledge the guidance and support from all the members of the FG-SSC Management Team, and especially Paolo Gemma (Huawei and FG-SSC Working Group 2 Coordinator) and Cristina Buetti (ITU).

Additional information and materials relating to this Technical Report can be found at: [www.itu.int/itu-t/climatechange](http://www.itu.int/itu-t/climatechange). If you would like to provide any additional information, please contact Cristina Buetti at [tsbsg5@itu.int](mailto:tsbsg5@itu.int).

## Table of Contents

		Page
<b>1</b>	<b>Introduction .....</b>	<b>590</b>
1.1	Scope .....	590
1.2	Background.....	590
<b>2</b>	<b>ICTs and EMF .....</b>	<b>591</b>
2.1	How wireless networks support ICT services? .....	591
2.2	Examples of ICT systems connected by wireless networks.....	592
2.3	Importance of wireless network connectivity.....	601
2.4	Wireless technology power and operating range .....	602
<b>3</b>	<b>EMF and health .....</b>	<b>603</b>
3.1	World Health Organization and EMF .....	604
3.2	EMF and health summary – World Health Organization .....	604
3.3	IARC classification for radio frequency fields.....	605
<b>4</b>	<b>EMF exposure limits .....</b>	<b>606</b>
4.1	Internationally harmonized EMF limits .....	606
4.2	EMF safety training.....	608
4.3	Compliance assessment standards for wireless networks and devices.....	609
4.4	Compliance for wireless networks .....	609
4.5	Typical antenna compliance zones for workers .....	609
4.6	Compliance for wireless devices .....	612
4.7	EMF compliance framework.....	613
4.8	Compliance assessment .....	613
4.9	Requirements for low power systems.....	614
4.10	Compliance for shared sites .....	614
<b>5</b>	<b>EMF health and safety information .....</b>	<b>615</b>
5.1	Compliance information.....	615
5.2	Health and safety information .....	615
5.3	Sources of information .....	616
<b>6</b>	<b>Community information, consultation and engagement.....</b>	<b>616</b>
6.1	Guidance on public participation and consultation .....	616
6.2	Why is consultation important? .....	616
6.3	Risk communication guidance.....	617
<b>7</b>	<b>Wireless ICT network infrastructure .....</b>	<b>617</b>
7.1	Mobile network base stations and antennas.....	617
7.2	Macro base stations and small cells.....	618
7.3	Sharing and co-location.....	620



	<b>Page</b>
7.4	Location of antennas and access restrictions ..... 621
7.5	Signage..... 622
<b>8</b>	<b>ICT wireless technologies..... 624</b>
8.1	Mobile network technologies – 3G and 4G..... 624
8.2	WiMAX..... 625
8.3	Wi-Fi..... 626
8.4	Mobile backhaul and radio relays ..... 626
8.5	Bluetooth ..... 627
8.6	DECT..... 628
<b>9</b>	<b>ICT antenna siting approval requirements ..... 628</b>
9.1	Antenna permit procedures ..... 628
9.2	Environmental impact assessment ..... 631
9.3	Schools, hospitals and similar community facilities..... 632
9.4	Access to public buildings and land..... 632
9.5	Planning exclusion zones..... 633
9.6	Visual integration with the environment ..... 634
9.7	Environmental impact assessment ..... 635
<b>10</b>	<b>Conclusions ..... 635</b>
	<b>Bibliography..... 637</b>
	<b>Annex 1 – Smart sustainable city - EMF check-list ..... 641</b>
	<b>Annex 2 – Summary of ICNIRP guidelines ..... 642</b>
	<b>Annex 3 – Summary of typical exposure levels..... 644</b>
	<b>Annex 4 – Abbreviations and acronyms ..... 645</b>

## Electromagnetic field (EMF) considerations in smart sustainable cities

### Executive Summary

Wireless and wired networks provide the underlying connections that underpin smart sustainable cities (SSC). The design and deployment of wireless networks must ensure compliance with the required quality of service as well as with the standards and regulations on human exposure to radio frequency (RF) electromagnetic fields.

This Technical Report details the electromagnetic field (EMF)<sup>1</sup> considerations in smart sustainable cities to ensure that the networks and connected devices operate safely and efficiently. Efficient deployment of wireless infrastructure will reduce the transmitted RF power in providing services and improve the efficiency of ICTs.

The key audience of this Technical Report includes city officials, town planners, urban developers, infrastructure providers, network operators and the public.

This Technical Report comprises the following key sections:

- **ICTs and EMF** – Provides a summary of how wireless networks support ICTs in the community, providing services that include smart metering, remote health care and medical monitoring, smart cars, mobile education, and smart homes and buildings.
- **EMF and health** – Provides an overview of the extensive research into EMF and health, and the conclusions from the World Health Organization (WHO).
- **EMF exposure limits** – Provides a summary of the international EMF exposure limits developed by the International Commission on Non-Ionizing Radiation Protection (ICNIRP) along with information on the application of the limits to workers and the general public.
- **EMF health and safety information** – Provides an overview of the most relevant information available on the linkages between EMF exposure, health and safety that can be used to respond to the requirements of various audiences.
- **Community information consultation and engagement** – Provides guidance on community engagement, consultation and risk communications in order to increase public and policymaker awareness, and foster better-informed discussions and citizen engagement in this field.
- **Wireless ICT network infrastructure** – Provides an overview of the infrastructure elements that form a wireless network, and explains the role of these different elements.
- **ICT wireless technologies** – Provides a summary of the various wireless technologies including 3G and 4G mobile telecommunications, worldwide interoperability for microwave access (WiMax), wireless fidelity (Wi-Fi), Bluetooth, digital enhanced cordless telecommunication (DECT), and the backhaul systems that connect the radio sites to the core telecommunications network and the Internet.
- **ICT antenna siting approval requirements** – Provides guidance on good practice policy for planning rules for ICT infrastructure.

This Technical Report concludes by providing city officials and decision makers with a ‘check-list’ that includes the key EMF-related aspects that need to be considered during the design and implementation of SSC, in order to ensure that its operation complies with EMF standards, and operate efficiently and safely.

---

<sup>1</sup> An electromagnetic field consists of waves of electric and magnetic energy moving together through space. Often the term ‘electromagnetic field’ or EMF is used to indicate the presence of electromagnetic radiation. Radio signals are one type of EMF.

## 1 Introduction

Connected devices, distributed sensors and Internet technologies are enabling smart sustainable cities (SSC) to capture valuable data, deploy new services and enhance existing services. The use of these tools can contribute to improving the effectiveness of city management, generating new growth opportunities for local businesses, improving sustainability and raising the quality of citizens' lives, among other benefits. Wireless technologies and services are playing a pivotal role in enabling smart sustainable cities around the world.

Wireless and wired networks provide the underlying connections that underpin smart sustainable cities. The design and deployment of wireless networks must ensure compliance with the required quality of service as well as with the standards and regulations on human exposure to radio frequency (RF) electromagnetic fields (EMFs). Efficient deployment of wireless infrastructure will reduce the transmitted RF power in providing services and support the maximum efficiency for ICTs.

### 1.1 Scope

This Technical Report details the EMF considerations in smart sustainable cities to ensure that the networks and connected devices operate safely and efficiently. The recommendations in this Technical Report are based on existing ITU and WHO technical and policy recommendations. Supplement 1 to Recommendation ITU-T K.91 includes a Guide on Electromagnetic Fields and Health that provides further information suitable for all stakeholders.

The target audiences of this Technical Report include:

- City officials
- Town planners
- Urban developers
- Infrastructure providers
- Network operators
- The public

This Technical Report provides guidance on the implementation of good policies for wireless networks and promotes the efficient deployment of smart sustainable cities strategies.

This Technical Report features a 'Smart Sustainable City EMF Check-list' designed to provide city officials and planners with a clear and easy-to-use reference, in order to ensure the efficient operation of smart city designs while complying with EMF safety standards (refer to Annex 1 for the check-list).

This Technical Report is not intended as a substitute for national EMF and wireless antenna siting requirements.

Guidance on terms and definitions in relation to smart sustainable cities can be found in related publications and Technical Reports from the ITU-T Focus Group on Smart Sustainable Cities. Abbreviations and acronyms are in Annex 4.

### 1.2 Background

Some countries around the world have witnessed the opposition of local stakeholders to the deployment of mobile network antenna sites, and similar smart sustainable city wireless infrastructure. This opposition may be linked to concerns about potential health risks caused by the exposure to EMF, as well as to concerns about aesthetics, impacts on property values, or issues such as privacy of information. With respect to EMF exposure, these fields are imperceptible and

unknown for the general public. This unawareness and imperceptibility can generate public distrust and rejection, which in turn can result in social conflicts and lead to delays in the deployment of new wireless technologies. In this context, city officials and elected representatives need to develop transparent policies and mechanisms for the implementation of wireless facilities.

## 2 ICTs and EMF

Radio communications and wireless systems are a part of everyday life in today's society. All radio communications systems use EMF in the radio frequency (RF) part of the electromagnetic spectrum. Wireless networks provide vital infrastructure and the underlying connections supporting the information and communication technologies (ICTs) for smart sustainable cities (SSC).

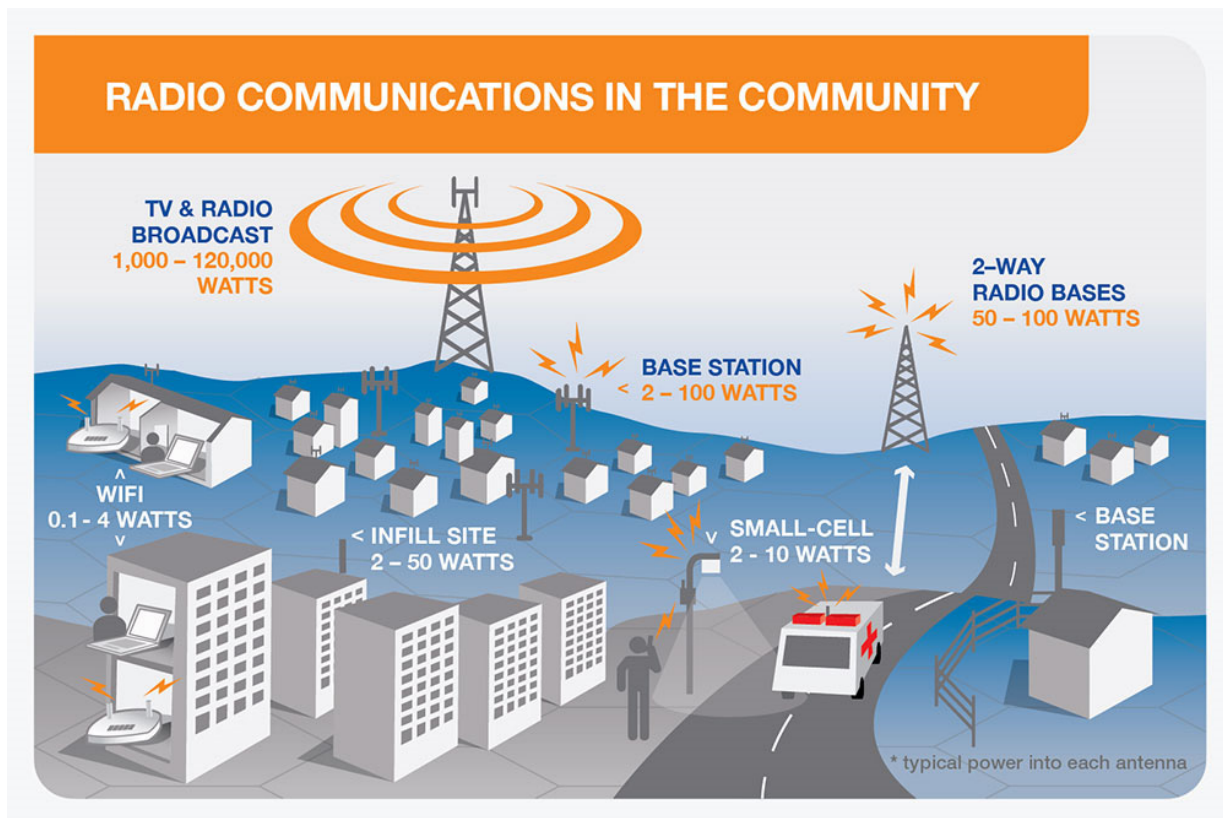
### 2.1 How wireless networks support ICT services?

The connected devices in our homes, businesses and communities are linked together through dedicated wireless networks. Connected devices typically operate at very low power and over short distances.

For example, the connected devices in a home can use a large number of radio access technologies, such as Wi-Fi, Bluetooth or protocols based on 434 or 868 MHz unlicensed services using industrial, scientific, and medical (ISM) spectrum as well as mobile networks.

Connected devices in larger buildings such as hospitals, universities and schools typically use dedicated wireless systems with antennas distributed throughout the facility.

Other wireless systems in our communities include, among other RF sources, television (TV) broadcast, amplitude modulation (AM) and frequency modulation (FM) radio broadcasting, mobile phones and their base stations, wireless broadband, paging services, cordless phones, baby monitors, emergency services (for example, police, fire, ambulance) as well as rural and country communications, such as wireless local loop technologies and high frequency (HF) two-way radio. Some common RF transmitter sources and their typical operating powers are shown in Figure 1. More information is provided in Table 1 of section 2.4.



NOTE – Power in watts = transmitter power into the antenna.

Source: Adapted from EMF Explained, available at <http://www.emfexplained.info/?ID=25186>

**Figure 1 – Typical radio and wireless communications in the community**

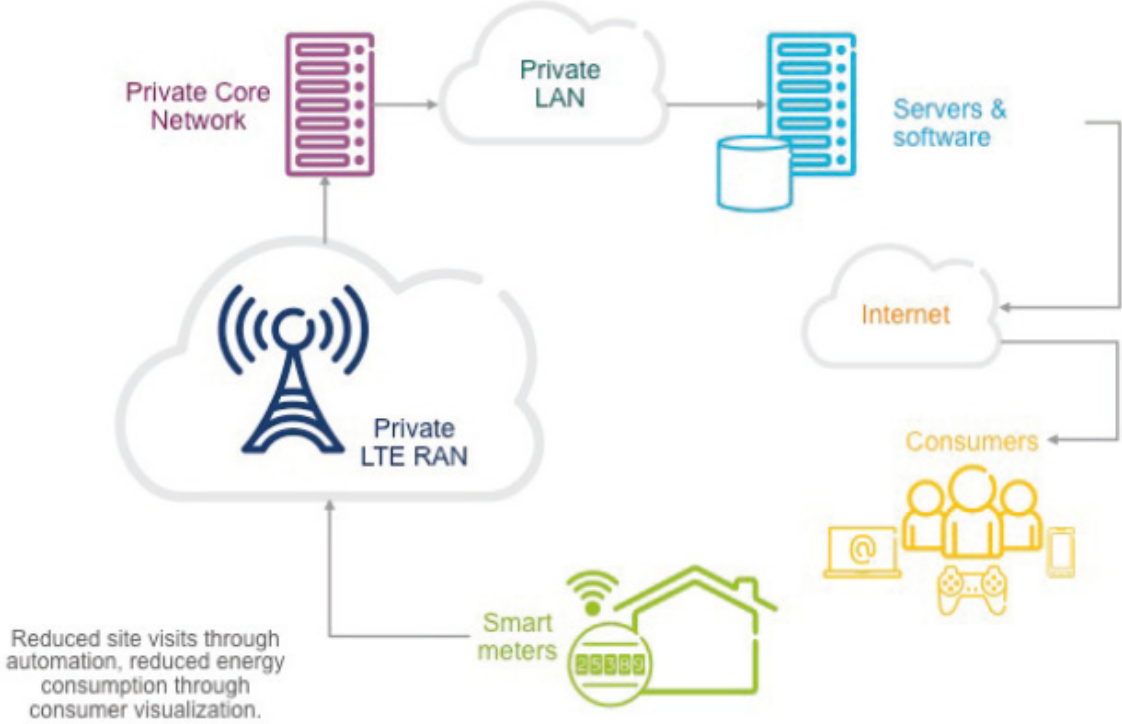
## 2.2 Examples of ICT systems connected by wireless networks

This section describes some of the SSC applications that can be supported by wireless networks.

### 2.2.1 Smart metering and power grids

Smart metering infrastructure of the power grid enables the continuous monitoring of electricity consumption across the grid, so that the loads and distribution can be optimized and save energy. To monitor consumption, the electricity meters are connected to a wireless device at the customer premises, which communicates back to the main network control centre. The electricity network sub-stations may also be connected to the main control centre through a wireless connection. Wireless connections can also be used for other services such as gas or water consumption meters.

Wireless technologies that are used for smart metering include cellular, ZigBee, Wireless M-Bus, WiMax and other mesh radio technologies. Some meters include more than one transmitter. For example, a 900 MHz band transmitter for connection to the monitoring network and a 2.4 GHz transmitter module for connection to wirelessly enabled equipment in the home. Figure 2 shows how data from smart meters can be transferred via a long-term evolution (LTE) wireless network to a server that is accessible by the end consumer over the Internet. This arrangement can provide information on power usage, billing and may facilitate remote access for home automation or to turn-off services such as air-conditioning that is not required. Analysis by Ericsson (2013) of the solution shown in Figure 2 found that there was a net positive effect on greenhouse gas (GHG) emissions at around 1% energy savings in the home (1% corresponds to a savings potential of about 80 kg of CO<sub>2</sub>e in Australia).



Source Ericsson (2013)

**Figure 2 – Smart metering solution using LTE wireless network**



### 2.2.2 Remote health care and medical monitoring

Health services and patient care use an extensive range of medical devices and monitoring probes. Within a hospital, dedicated wireless networks inside the buildings and facilities provide the connection for these devices.

Remote monitoring and connection for medical devices is possible in the wider community through the use of public mobile and wireless networks as well as domestic Wi-Fi networks. A newly formed partnership between ITU and WHO constitutes a relevant example of the use of mobile technology to improve non-communicable disease (NCDs) prevention and treatment. Mobile solutions used as part of this initiative are primarily short message service (SMS) or apps based, and will include a range of services such as mAwareness, mTraining, mBehavioural change, mSurveillance, mTreatment, mDisease management and mScreening, among others. This enables significant benefits through extended and remote medical care for broad sectors of the population.



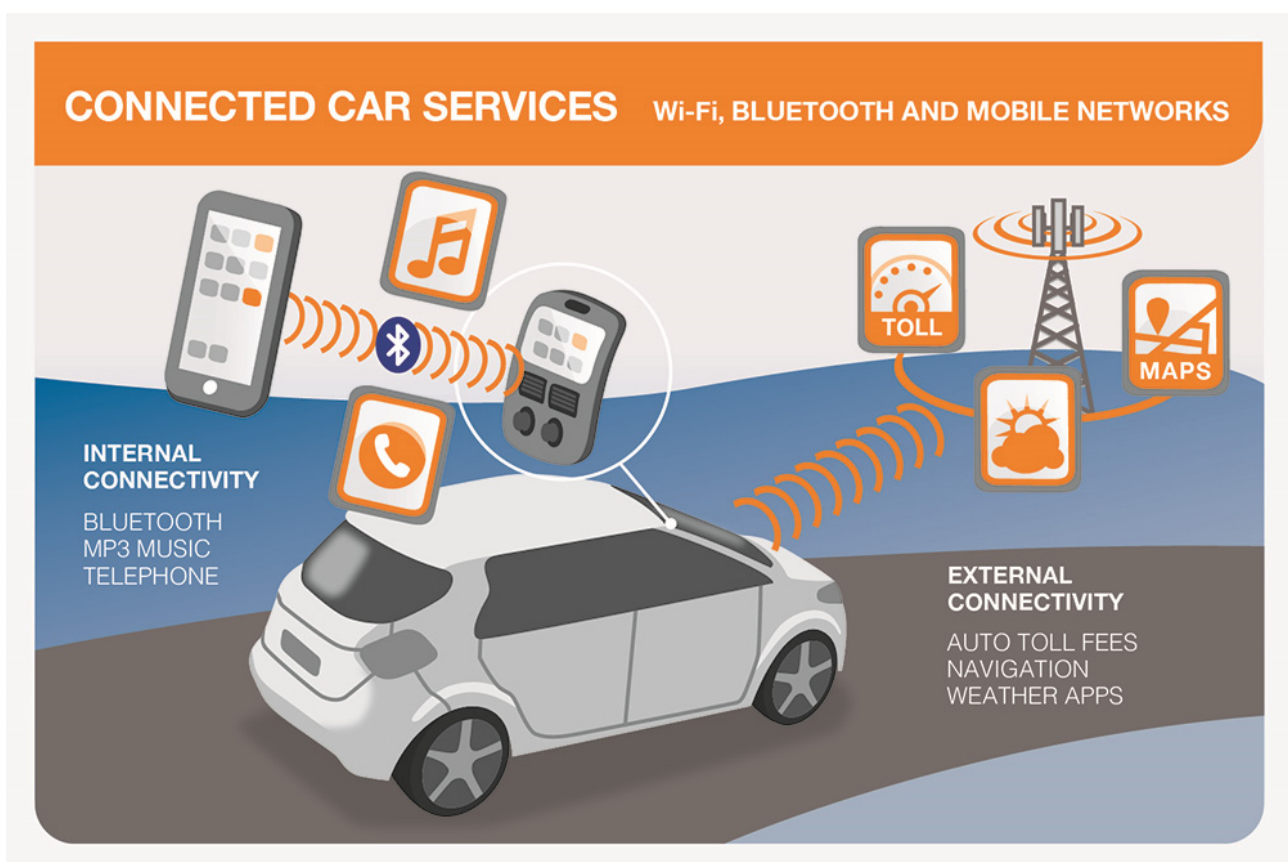
Source: [http://www.itu.int/en/ITU-D/ICT-Applications/eHEALTH/Pages/Be\\_Healthy.aspx](http://www.itu.int/en/ITU-D/ICT-Applications/eHEALTH/Pages/Be_Healthy.aspx)

**Figure 3 – ITU-WHO mobile health for non-communicable disease (NCDs) initiative**

### 2.2.3 Smart connected cars

Smart connected cars offer a range of sophisticated technology advances in navigation, security, driver and vehicle safety, servicing and maintenance. Smart cars utilize mobile networks for external connectivity, as well as Wi-Fi and Bluetooth for internal links. The effectiveness of connected cars in a smart city depends largely on the coverage and on the capacity of the supporting mobile networks. Smart navigation, based on global positioning system (GPS) location and central traffic information (such as Waze<sup>2</sup>), save time and greenhouse gas (GHG) emissions. Short-range devices such as transport and traffic telematics (TTT), road tolling, automatic meter reading (AMR), street lamp control and railway applications, are among the technologies that characterize the operation of SSC.

Within this context, Figure 4 illustrates the way in which smart connected cars are interlinked with a series of mobile-based functionalities (for example, temperature management, battery monitoring, technical maintenance, navigation), ultimately contributing to more efficient mobility.



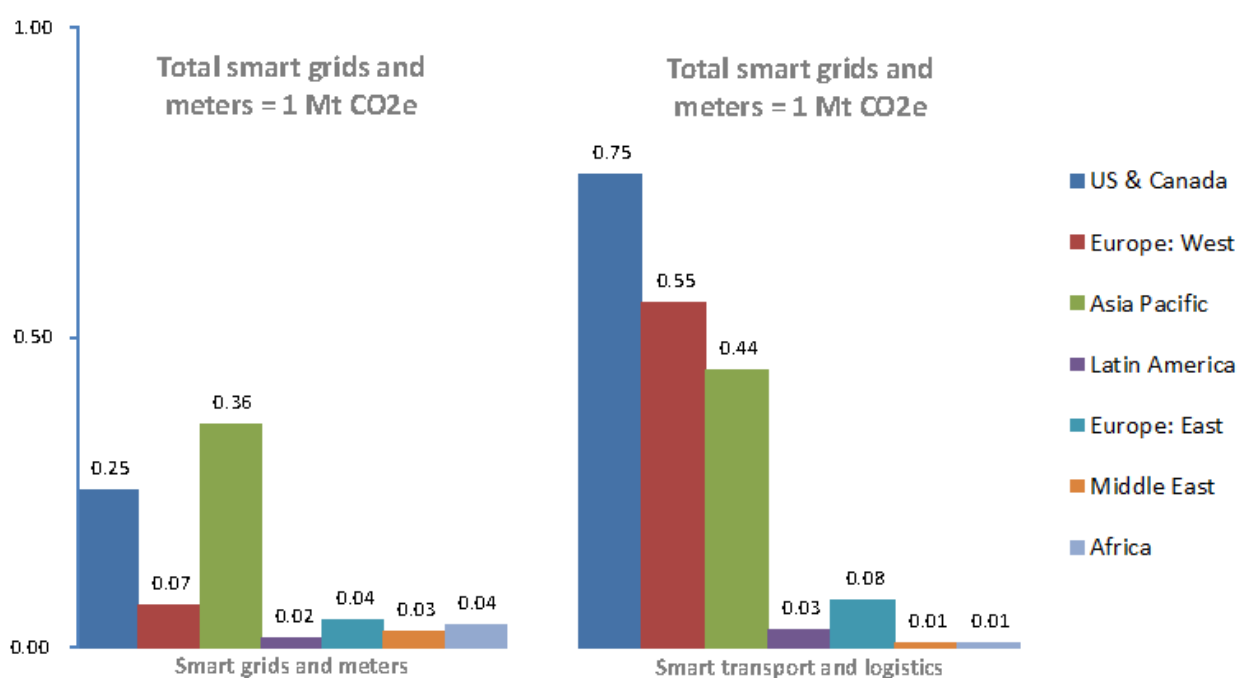
Source: Adapted from ITU (2014): [http://www.itu.int/en/fnc/2014/Documents/S5P3\\_St%3%a9phane\\_Petti.ppt](http://www.itu.int/en/fnc/2014/Documents/S5P3_St%3%a9phane_Petti.ppt)

**Figure 4 – A view of connected car services for a more comfortable and efficient mobility**

<sup>2</sup> <https://www.waze.com/>

### 2.2.4 Fleet management

Wireless tracking devices fitted to vehicles can strengthen the efficiency of fleet logistic operations, while reducing energy consumption and GHG emissions. These tracking devices can feed data to centralized fleet management software or to other vehicles in the fleet. In addition to location, they can also be used to remotely monitor loading capacities, enabling vehicle loading optimization. For example, the vehicle’s route can then be adjusted to make use of spare capacity. Further benefits can arise in SSC where wireless devices can be used in applications such as traffic volume monitoring, connected road signs and traffic light synchronization. Such wireless devices are part of the intelligent traffic control (ITC) system. The impact of GHG savings of smart transportation and logistics, and smart grids and smart meters, have been estimated for different regions around the world, as illustrated in Figure 5.



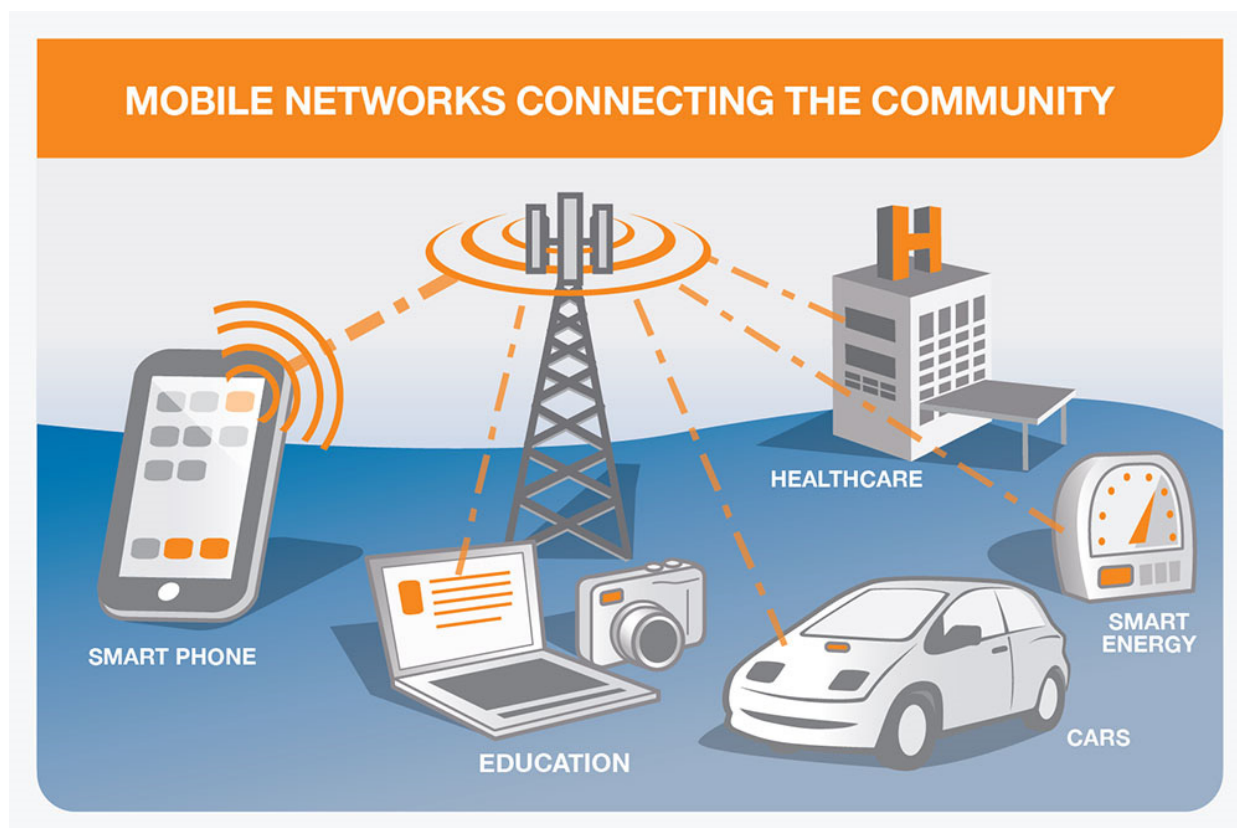
Source: GSMA, Mobile’s Green Manifesto (2012).

**Figure 5 – Estimated GHG savings in smart transportation and logistics, and smart grids and smart meters, MtCO<sub>2</sub>e, 2011**

### 2.2.5 Mobile networks connecting ICTs

Mobile networks are increasingly utilized as a core network to connect ICT systems and devices. As they continue to evolve and cater for increased data speeds, capacity, and coverage, these networks become an ideal solution for many ICT applications.

With careful planning, mobile networks can provide cities with very cost effective and efficient connectivity solutions for ICT systems. Increasing deployments of fourth generation (4G) and higher speed technologies, they are being used in the support of multiple ICT solutions, whilst providing mobile services to communities. Figure 6 shows how mobile networks connect both people and things and thereby support SSC applications, for example, smart energy, smart education, and smart health care.



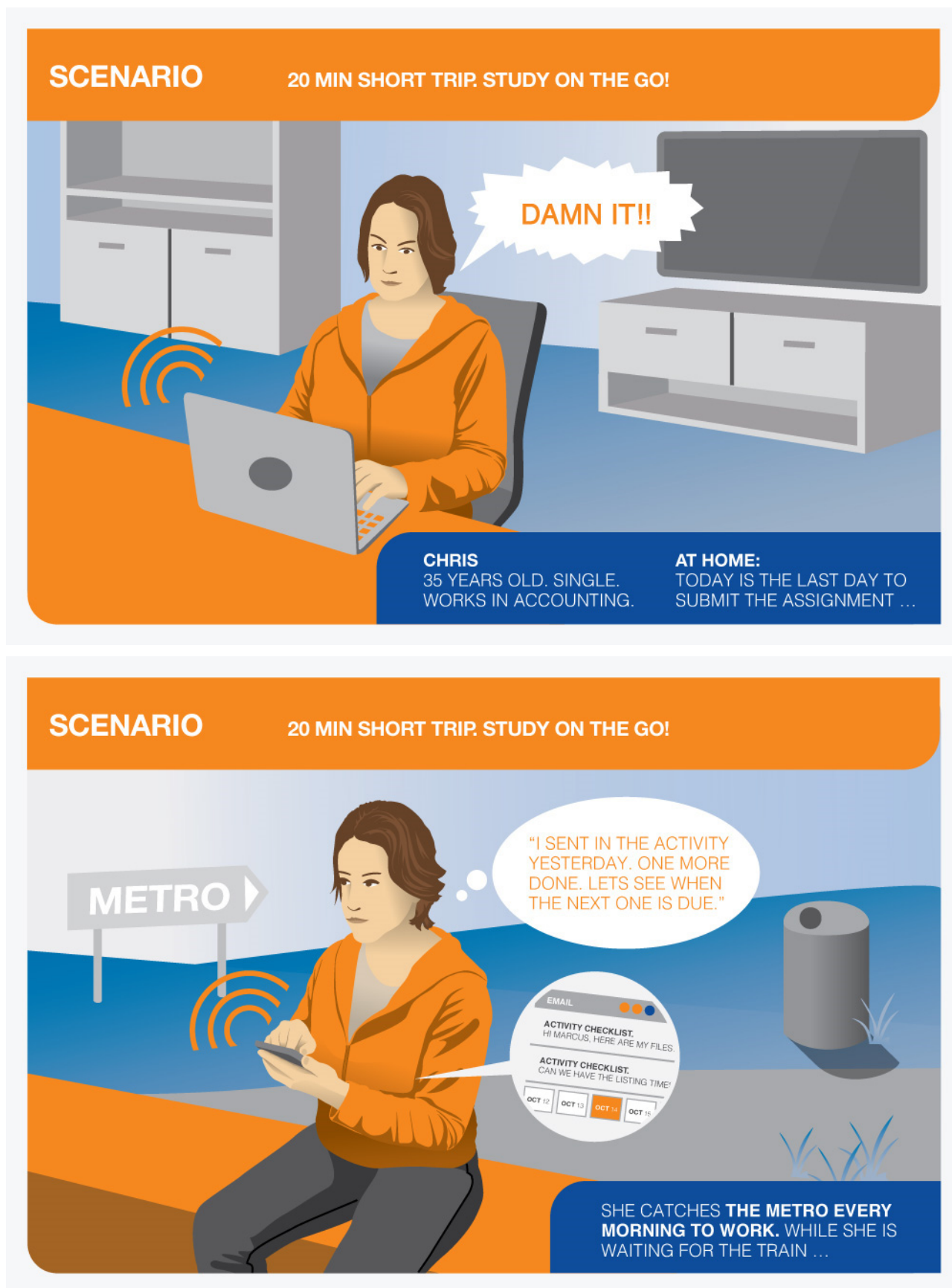
Source: Adapted from GSMA (2013).

**Figure 6 – Examples of connected devices and applications through a mobile network**

### 2.2.6 Mobile education (mEducation)

Mobile education (mEducation) provides students, teachers, and all stakeholders interested or involved in capacity building with the ability to learn anywhere, and anytime. mEducation makes educational content available over mobile networks to devices such as tablets, smart phones and feature phones. Traditional learning is being transformed by non-traditional mobile technology environments that are beginning to shape the future of education. mEducation represents a powerful shift in the way in which education is delivered and accessed, as well as in the way content is created, adapted and appropriated by the end user. Beyond the supply of new learning mechanisms, mEducation enhances teaching and assessment, and facilitates educational administration and management via mobile technologies that are increasingly available.

Figure 7 provides an example of how mobile devices can increase access to learning opportunities by allowing increased flexibility and diversity in the access to and use of educational programmes.





**SCENARIO**

20 MIN SHORT TRIP. STUDY ON THE GO!



**SCENARIO**

20 MIN SHORT TRIP. STUDY ON THE GO!







Source: Adapted from GSMA, Orange, Universitat Oberta de Catalunya.  
Case study: University goes portable with tablet technology (2012.)

Figure 7 – Storyboard example of mobile devices increasing access to learning

### 2.2.7 Smart buildings and smart houses

Mobile connectivity can enable emission reductions in buildings by increasing automation and control, for example, in building management systems, heating, ventilation and air conditioning (HVAC) and lighting. Mobile technology can enable users to control building technologies remotely, for example, by adjusting HVAC settings from a mobile device. Mobile machine-to-machine (M2M) devices can be embedded in HVAC, lighting and other appliances across a building, either as the main means of communication with access points or as a back-up facility to short-range M2M communication in the case of critical systems. A recent report by GSMA (2012) suggests that potential reductions in GHG emissions from smart buildings are estimated to be in the range of 30 MtCO<sub>2e</sub> by 2020.

Short range devices (SRDs) enable smart houses. Technologies such as Z-Wave provide indoor network of remote controls, smart smoke alarms and security sensors. Figure 8 illustrates an example of SRDs enabling an intelligent house by enabling automation and monitoring of temperature, appliances, electricity, and so on.



Source: ITU Workshop on Short Range Devices and Ultra Wide Band', Geneva, 3 June 2014, available at <http://www.itu.int/en/ITU-R/study-groups/workshops/RWP1B-SRD-UWB-14/Presentations/International,%20regional%20and%20national%20regulation%20of%20SRDs.pdf>

**Figure 8 – Short range devices enabling smart and intelligent house**

### 2.3 Importance of wireless network connectivity

As the analysis and the examples presented thus far suggest wireless networks provide essential connection of devices in SSC. Without network connection, the devices cannot communicate and operate correctly. The design and location of the antenna sites in a wireless network underpins the entire operation of SSC. The base stations of mobile networks need to be located in close proximity to the devices in order to ensure connection and improved efficiency in their operation. The connected devices operate at low power and have a limited operating distance. The range of the devices usually constitutes the limiting design factor when choosing the physical locations to install base stations.

## 2.4 Wireless technology power and operating range

Table 1 provides a summary of the ICT wireless technologies, including typical peak transmitter powers, equivalent isotropic radiated power (EIRP) and operating distances. The information is relevant to city officials involved in the development of antenna siting policies or the approval of site applications. It illustrates the low powers used by wireless network technologies in comparison to broadcast services.

**Table 1 – Summary of the ICT wireless technologies, transmitter powers and operating distances**

Technology/Device	Transmitter power	EIRP <sub>max</sub>	Operating range	Remarks
<b>Short Range Devices</b>				
Bluetooth	0.001 to 0.1 W	0.1 W	up to 100 m	Typical antenna gain is 0 dBi
Smart meter	up to 0.1 W	0.1 W	up to 100 m	
Radio frequency identification (RF-ID)	0.001 – 1 W	4 W	up to 500 m	Antenna gain up to 6 dBi
Wi-Fi access point	0.1 – 1 W	4 W	up to 500 m	
DECT base station	0.25 W	0.25 W	up to 100 m	Typical antenna gain is 0 dBi
DECT phone	0.25 W	0.25 W	up to 100 m	
<b>Radiocommunication services</b>				
Mobile phone	Up to 0.25 W (time averaged)	2 W	1 – 30 km	Antenna gain is 0 dBi
WiMAX router	up to 1 W	1 W	~5 km	Typical antenna gain is 0 dBi
WiMAX network site	3 W	100 W	~35 km	Typical antenna gain is 14 dBi
Mobile network base station (small cells)	1 – 10 W	up to 100 W	100 m – 1 km	Typical antenna gain is 5 – 10 dBi
Mobile network base station (macro site)*	10 – 80 W	2,600 W	1 – 30 km	Additional gain of about 18 dBi and feeder loss of about 3 dB for base station antennas
Typical FM radio station transmitter	1 – 20 kW	197 kW (ERP=120 kW)	< 100 km	Additional gain of about 13 dBi and feeder losses 2 dB per antenna
VHF TV transmitter**	1 – 30 kW	328 kW (ERP=200 kW)	< 150 km	
Typical UHF TV transmitter*	1-40 kW	1640 kW (ERP=1000 kW)	< 100 km	Additional gain about 16 dBi
UHF DVB-T transmitter	1 – 5 kW	246 kW (ERP=150 kW)	< 100 km	
Typical AM radio station transmitter***	50 – 1,200 kW	3,280 kW (ERP=2000 kW)	>300 km	Additional gain about 4 dBi

Source: Recommendation ITU-T K.70, Appendix II; Recommendation ITU-R BS.1698-0, section 2.1.5.

\* Per carrier.

\*\* Nominal analogue TV transmitter power is peak power.

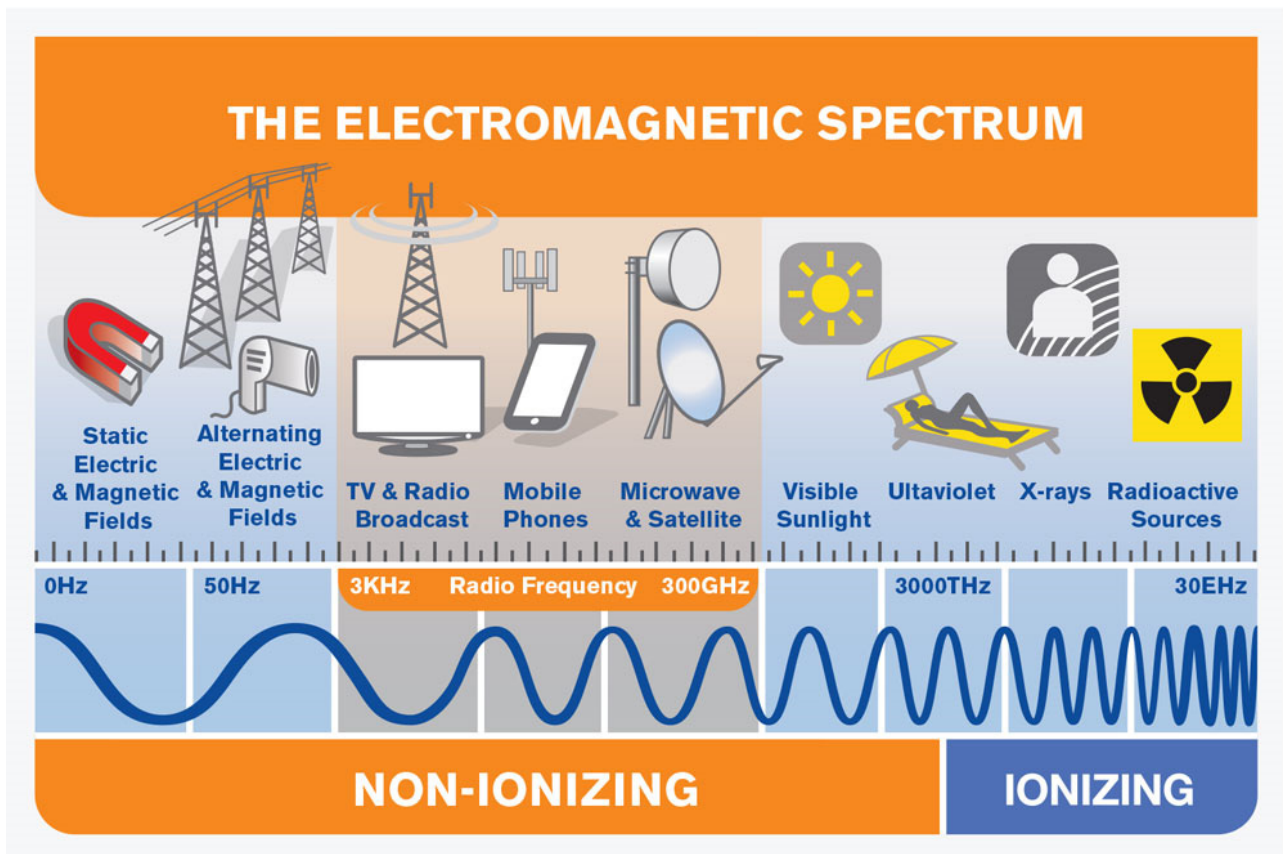
\*\*\* Nominal AM transmitter power is carrier power.

UHF = Ultra High Frequency; VHF = Very High Frequency (see ITU Radio Regulations, Vol. 1, Article 2, 2008).

### 3 EMF and health

Exposure to electromagnetic fields (EMFs) in everyday life is not a recent occurrence. Humans have been exposed to natural EMF throughout their lifetime; however, human sources of EMFs have increased in the past century with the development of technology and radio communications.

The electromagnetic spectrum extends from static electric and magnetic fields, domestic electric power frequencies (50/60 Hz) through radio frequency, infrared, and visible light to gamma-rays (Figure 9).



Source: ITU-T, Supplement 1 to Recommendation ITU-T K.91 - Guide on Electromagnetic Fields and Health, 2014.

**Figure 9 – The electromagnetic spectrum and typical sources of electromagnetic fields**

Radio signals are a form of electromagnetic energy (or electromagnetic radiation (EMR)). Radio signals are non-ionizing, which means that they cannot directly impart enough energy to a molecule to break or change chemical bonds. This is in contrast to ionizing radiation, such as X-rays, which can strip electrons from atoms and molecules, producing changes that can lead to tissue damage and possibly cancer.

It has been known for many years that exposure to sufficiently high levels of radio signals can heat biological tissue and potentially cause tissue damage if the human body cannot cope with the extra heat. Much of the public concern relates to the possibility of health hazards from long-term exposures at levels too low to produce measurable heating.

### 3.1 World Health Organization and EMF

Electromagnetic fields (EMFs) of all frequencies represent one of the most common and fastest growing environmental exposures. As part of its Charter to protect public health and in response to public concern, the World Health Organization (WHO)<sup>3</sup> established the International EMF Project in 1996. The purpose of the EMF Project is to assess the scientific evidence of possible health effects of EMF in the frequency range from 0 to 300 GHz.

#### Box 1. The World Health Organization (WHO)

The WHO is the directing and coordinating authority for health within the United Nations system. The WHO has responsibility for:

- Providing leadership on global health matters;
- Shaping the health research agenda;
- Setting norms and standards;
- Articulating evidence based policy options;
- Providing technical support to countries; and
- Monitoring and assessing health trends.

Further information about the EMF Project can be found at: <http://www.who.int/emf>

### 3.2 EMF and health summary – World Health Organization

Extensive research has been conducted into the potential health hazards of exposure to many parts of the frequency spectrum, including the RF-EMF used by mobile phones, base stations and other wireless systems and services.

The data emerging from this research has been analysed in more than 150 reports<sup>4</sup> by expert review groups mandated by national or international authorities (Box 2). Weighing the whole body of evidence, there is no evidence to convince experts that exposure below the guidelines set by the International Commission on Non-Ionizing Radiation Protection (ICNIRP)<sup>5</sup> carries any health risks, for adults, pregnant women or children.

WHO<sup>6</sup> states:

*‘Extensive research has been conducted into possible health effects of exposure to many parts of the frequency spectrum including mobile phones and base stations. All reviews conducted so far have indicated that exposures below the limits recommended in the ICNIRP (1998) EMF guidelines, covering the full frequency range from 0-300 GHz, do not produce any known adverse health effect. However, there are gaps in knowledge still needing to be filled before better health risk assessments can be made.’*

<sup>3</sup> <http://www.who.int/>

<sup>4</sup> <http://www.gsma.com/publicpolicy/mobile-and-health/science-overview/reports-and-statements-index>

<sup>5</sup> <http://www.icnirp.org/cms/upload/publications/ICNIRPemfgdl.pdf>

<sup>6</sup> <http://www.who.int/peh-emf/research/en/>. Accessed 5 September 2014.



**Box 2. Recent expert group conclusions on EMF & health**

*"...no evidence has been found that exposure to radiofrequency electromagnetic fields has a negative influence on the development and functioning of children's brains, not even if this exposure is frequent."*

Health Council of the Netherlands (2011).

*"...it is the opinion of ICNIRP that the scientific literature published since the 1998 guidelines has provided no evidence of any adverse effects below the basic restrictions and does not necessitate an immediate revision of its guidance on limiting exposure to high frequency electromagnetic fields."*

International Commission on Non-Ionizing Radiation Protection (ICNIRP, 2009).

*"...Recent research on exposure from transmitters has mainly focused on cancer and symptoms, using improved study designs. These new data do not indicate health risks for the general public related to exposure to radiofrequency electromagnetic fields from base stations for mobile telephony, radio and TV transmitters, or wireless local data networks at home or in schools."*

SSMs Independent Expert Group on Electromagnetic Fields, (Sweden, 2013).

### 3.3 IARC classification for radio frequency fields

The International Agency for Research on Cancer (IARC) is the specialized cancer agency of the World Health Organization. The objective of the IARC is to promote international collaboration in cancer research. The Agency is inter-disciplinary, bringing together skills in epidemiology, laboratory sciences and biostatistics to identify the causes of cancer so that preventive measures may be adopted and the burden of disease and associated suffering reduced.

The IARC Monographs Programme is a core element of the Agency's portfolio of activities, with international expert working groups evaluating the evidence of the carcinogenicity of specific exposures.

In May 2011, 30 scientists from 14 countries met at the IARC<sup>7</sup> in order to assess RF-EMF. This assessment was published as Volume 102 of the IARC Monographs<sup>8</sup>. Based on mixed epidemiological evidence on humans regarding an association between exposure to RF-EMF from wireless phones and head cancers (glioma and acoustic neuroma), RF-EMF fields have been classified by the IARC as possibly carcinogenic to humans (Group 2B). The Group 2B category is used when a causal association is considered credible, but when chance, bias or confounding cannot be ruled out with reasonable confidence.

<sup>7</sup> <http://www.iarc.fr/en/media-centre/pr/2011/index.php>

<sup>8</sup> <http://monographs.iarc.fr/ENG/Monographs/vol102/>



Following the IARC classification, the WHO<sup>9</sup> issued an updated Fact Sheet in June 2011, stating that: *'To date no adverse health effects have been established as being caused by mobile phone use'*. The WHO Fact Sheet notes that:

*'While an increased risk of brain tumors is not established, the increasing use of mobile phones and the lack of data for mobile phone use over time periods longer than 15 years warrant further research of mobile phone use and brain cancer risk. In particular, with the recent popularity of mobile phone use among younger people, and therefore a potentially longer lifetime of exposure, WHO has promoted further research on this group. Several studies investigating potential health effects in children and adolescents are underway.'*

The WHO<sup>10</sup> states that studies to date provide no indication that environmental exposure to RF fields, such as from base stations, increases the risk of cancer or any other disease.

Furthermore, WHO<sup>11</sup> Fact Sheet 304 states:

*'Considering the very low exposure levels and research results collected to date, there is no convincing scientific evidence that the weak signals from RF Base stations and wireless networks cause adverse health effects.'*

Further information on the IARC classification for RF-EMF is available (Supplement 1 to Recommendation ITU-T K.91).

## 4 EMF exposure limits

Scientific research over many decades has enabled national and international health authorities to establish safety limits for exposure to electromagnetic fields. Exposure limits vary depending on the EMF frequency and incorporate conservative safety margins for added protection.

In the following sections, the basis for the international EMF exposure limits is summarized along with information on application of the limits to workers and the general public. The methods used for assessing compliance with EMF exposure standards are introduced and typical compliance zones for mobile communication network antenna are described.

### 4.1 Internationally harmonized EMF limits

The WHO encourages the adoption of exposure limits that provide similar levels of health protection for all people. The International Commission on Non-Ionizing Radiation Protection (ICNIRP) is a non-governmental organization which has official relations with the WHO. The ICNIRP guidelines form the basis of WHO<sup>12</sup> and ITU Recommendations to governments and have been widely adopted around the world.

ITU<sup>13</sup> recommends the exposure limits for EMF developed by ICNIRP where no national limits exist. National EMF exposure limits based on the ICNIRP guidelines provide a global reference, an internationally harmonized approach and a global consistency of exposure protection.

<sup>9</sup> <http://www.who.int/mediacentre/factsheets/fs193/en/>

<sup>10</sup> <http://www.who.int/features/qa/30/en/>

<sup>11</sup> <http://www.who.int/peh-emf/publications/facts/fs304/en/>

<sup>12</sup> WHO, Framework for developing health-based electromagnetic field standards, 2006.

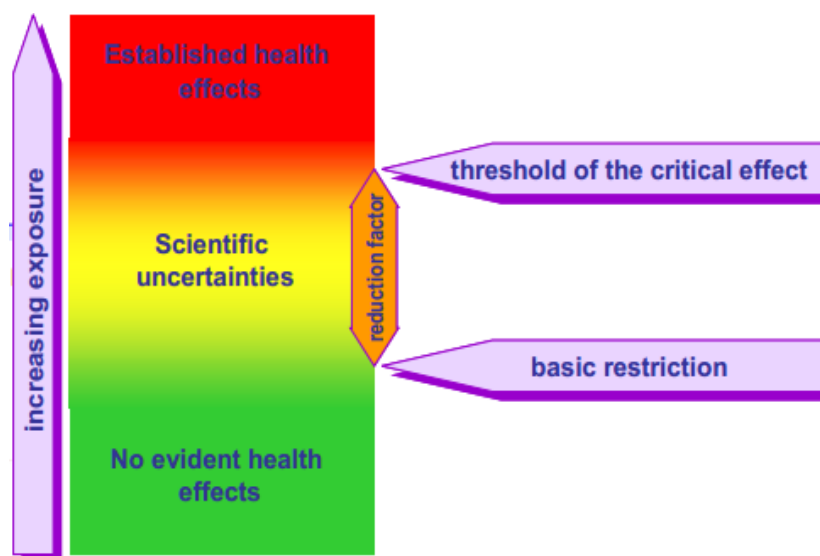
<sup>13</sup> Recommendation ITU-T K.52.

The ICNIRP EMF guidelines cover the frequency range 0-300 GHz which includes the frequency of all wireless ICT systems and devices.

The ICNIRP EMF guidelines are based on a threshold level of exposure above which health effects have been established. A reduction factor is then applied to establish a safe exposure level for workers (occupational exposure, factor of 10) and the general public (factor of 50). The rationale explaining the lower safety factor for the occupational exposure is provided in Annex 2.

The basis of the ICNIRP guidelines at radio frequencies are established effects that are related, in the radio frequency (RF) domain, to temperature rise (i.e., thermal effects). ICNIRP states that non-thermal effects have not been established and their relevance to human health is uncertain. Therefore, ICNIRP states that it is impossible to use reports of such effects as a basis for setting limits on human exposure to these fields.

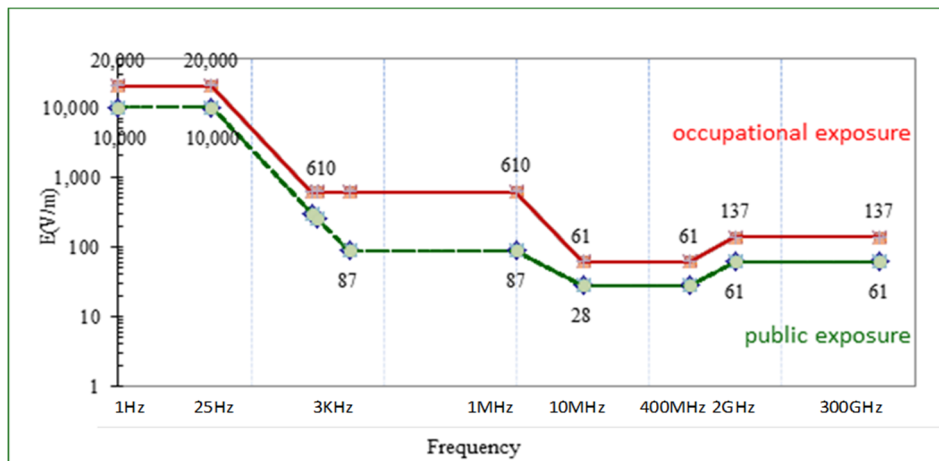
The reduction factors for the general public and workers, as shown in Figure 10, are designed to account for any scientific uncertainties, variations in the population health and environmental conditions.



Source: ICNIRP presentation: EMF Safety Guidelines - The ICNIRP View presented at the ITU Workshop on Human Exposure to Electromagnetic Fields, Turin, 9 May 2013 available at <http://emfguide.itu.int/pdfs/ITU-EMF-Workshop-Turin2013-ICNIRP-Matthes.pdf>

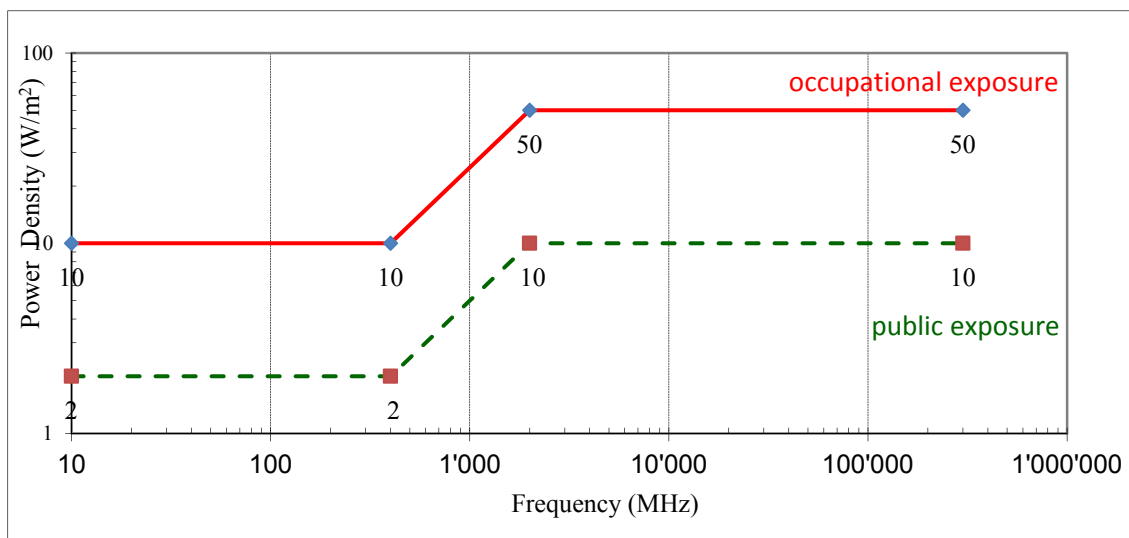
**Figure 10 – ICNIRP exposure limits and reduction factor**

ICNIRP (1998, p.511, Tables 6 and 7; see Annex 2 of this Technical Report) define the exposure thresholds. The basic restriction expressed in watt/kg are the fundamental limits while the reference levels, expressed in V/m, A/m or W/m<sup>2</sup>, are derived from the basic restrictions and the relationship between exposure to an incident field and the power absorbed by a human body. Annex 2 of this Technical Report provides a summary of the ICNIRP guidelines. Figures 11 and 12 depict ICNIRP reference levels at different frequencies for the electric field (Figure 11) and power density (Figure 12). The limit values are shown for both occupational (solid-red) and general public (dashed-green) exposures (Mazar, forthcoming).



Source: Mazar, 'International, Regional and National Regulation and Standardisation' [forthcoming].

**Figure 11 – ICNIRP electric field strength reference levels for public and occupational exposures**



Source: Mazar, 'International, Regional and National Regulation and Standardisation' [forthcoming].

**Figure 12 – ICNIRP power density reference levels above 10 MHz for public and occupational exposures**

#### 4.2 EMF safety training

Specialized EMF safety training is very important for workers that need to access areas where the EMF exposure levels exceed the general public limits, for example, on radio towers or on building rooftops with antennas. EMF safety training is also very important for workers that service or work ICT devices and equipment. These programmes can be tailored to suit the level of work and expertise required in each case.

EMF safety training typically covers the following topics:

- Understanding EMF safety limits.
- Identifying ICT equipment and antennas.
- Identifying areas that exceed public exposure limits around antenna installations.
- Working safely on antennas.
- Working safely on transmitters.
- Using EMF safety meters and personal monitors.

The IEEE recommended practice for RF safety programs provides guidance on topics that should be included in RF safety awareness training (IEEE C95.7, 2005).

#### 4.3 Compliance assessment standards for wireless networks and devices

Compliance with public or worker (occupational) EMF exposure limits can be assessed through calculation or measurement. Detailed guidance on assessments is provided in technical standards produced by ITU and other international organizations such as the International Electrotechnical Commission (IEC) or the European Committee for Electrotechnical Standardization (CENELEC). Key standards are mentioned in the relevant sections that follow. In some cases, national requirements may be specified based on the international technical standards.

In general, calculation may be used for simpler installations where only one significant RF source is present, or where there are few objects in the nearby environment, for example, calculation of compliance boundaries for antennas on a mobile base station mast. Some sophisticated calculation tools allow for assessments for very complex installations, and can consider the effects of the surrounding environment. Furthermore calculations are the only tool in the case of installations that are in the planning stage or not operating yet. Measurements may be required for complex sites with multiple transmitters or many reflecting objects, for example, a rooftop with many antennas that have overlapping transmission patterns. For some types of low power antennas or devices with integral antennas, the manufacturer may provide the compliance information. This may include position requirements to ensure that the public or workers cannot access areas close to the antenna (Recommendation ITU-T K.61 (2008); IEC 62232 (2011)).

#### 4.4 Compliance for wireless networks

In principle, RF-EMF levels decrease when a person moves further away from the source, (for example, a transmitting antenna). For each antenna, the RF exposure level can be calculated based on its emission characteristics, or measured using appropriate methods (Recommendation ITU-T K.61: 2008; IEC 62232, 2011). The distance at which the RF exposure level is always below the RF exposure limit is called the 'compliance distance'. The compliance distance may be based on a field strength, power density or a specific absorption rate (SAR) evaluation (for example, for small cells, portable devices and tablets). In either case, the compliance distance incorporates a conservative safety margin.

It is also possible to determine a three dimensional (3D) compliance boundary around an antenna. The region inside the compliance boundary is often called the 'exclusion zone'.

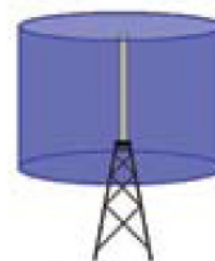
The advantage of defining a compliance boundary is that it specifies the compliance distance in all directions. Base station antennas are usually directional and therefore the RF level behind the antenna is much smaller than in front of it.

#### 4.5 Typical antenna compliance zones for workers

The following typical types of antenna are commonly found at a base station or at antenna sites. A photo of the antenna(s) is given to illustrate each antenna as well as a diagram indicating the shape of the compliance boundary (shown in blue) for workers. Please note that while the locations described refer to areas directly in line with the antenna, the exclusion zone/compliance boundary in other directions (e.g. above, below, behind) may, though small (in the range of several centimetres), exist. In addition, the exclusion for the public will be somewhat larger.

### Omnidirectional coverage

These antennas radiate RF energy equally in all directions in the horizontal plane. The antenna input power is typically 10 – 80 watts, and the compliance boundary for a worker typically extends 0.1 – 1.5 meters from the antenna.



(shown in blue: compliance boundary - workers)

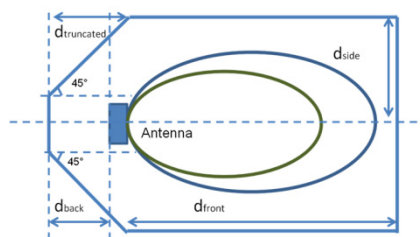
### Sector coverage

These antennas restrict most of their radiated RF energy to a narrow angular sector in their forward direction (typically 60 to 120 degrees in the horizontal plane, typically 8 to 14 degrees in the vertical plane). The photograph shows two sector antennas, one mounted above the other. The antenna input power is typically 10 – 80 watts, and the compliance boundary for a worker extends typically 0.2 – 3 meters from the front face of the antenna.



(shown in blue: compliance boundary - workers)

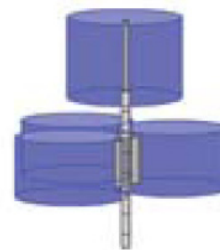
In the diagram, the compliance zone is shown conservatively as covering the full height of the antenna; however, due to the vertical antenna pattern beam width the exclusion zone boundary may be narrower in the vertical direction.



Where antennas are mounted on the exterior wall of a building, there is typically no compliance zone within the building to the rear of the antenna.

### Complex or shared base stations

Antennas are often grouped together on masts. The combination illustrated here is that of an omnidirectional antenna mounted above a cluster of three sector antennas. In the case that multiple antennas are present on a site, whenever an additional antenna is installed, the compliance boundary of each antenna should be evaluated again, taking into account the additional exposure of the newly installed antenna.



(shown in blue: compliance boundary - workers)

In the diagram, the compliance boundaries are shown independently for each antenna. For antennas that are close together or operate at high powers, the zones may overlap leading to large exclusion zones than for the individual antennas.

### Small cells

Small cells are low-powered radio access nodes that operate in licensed or unlicensed spectrum that have a range of a few meters up to 1 to 2 kilometres. Small cells can be used to provide in-building or outdoor wireless service. They are often used to increase the network capacity and coverage in localized areas.



(shown in blue: compliance boundary – workers)

As these are low powered devices, compliance distances are very small and may be incorporated within the antenna cover. For some sites, installation recommendations may be provided to ensure compliance with limits.

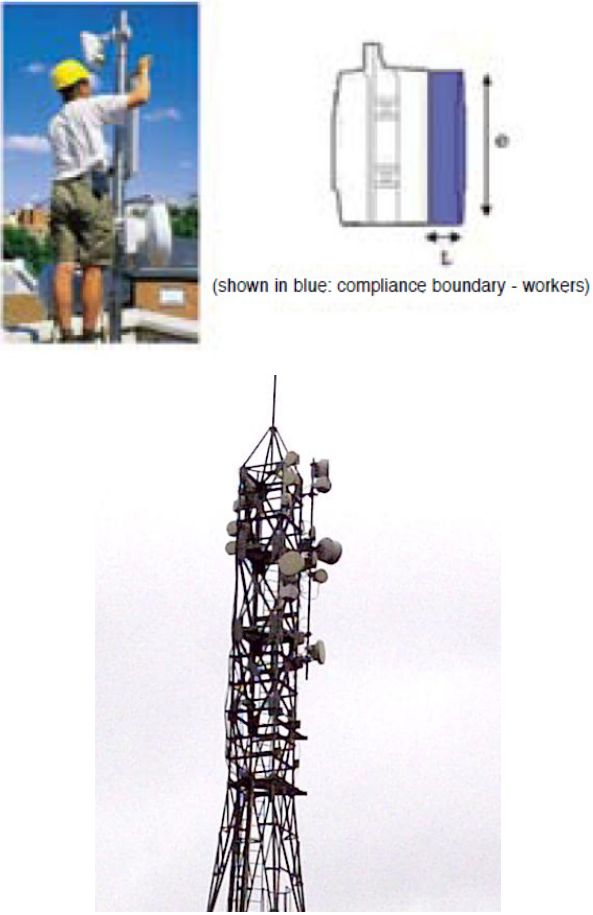


**Radio relay (also known as fixed point-to-point radio link)**

Radio relays operate in frequency bands that typically range from 1.4 GHz up to 86 GHz and beyond. The most common antenna type is a parabolic dish antenna characterized by high directivity and low radiation outside the main beam direction. Radio relays generally operate in line of sight and are therefore installed so that the radio path is inaccessible by the general public.

The distance in front of the dish antenna to the EMF exposure compliance boundary can range from centimetres to metres depending on the transmitter power used, antenna dimensions and gain. It is recommended that the compliance distance be assessed either by measurement or calculation as part of the site safety assessment.

If the antenna is accessible, workers should never step in front of the dish up to the EMF exposure boundary to ensure compliance with the safety guidelines, and also because it will interrupt radio link.



(shown in blue: compliance boundary - workers)

Source: Adapted from GSMA and MMF (2008).

**Figure 13 – Examples of typical worker compliance zones for a range of antenna installations used for mobile networks**

The shape of the compliance boundary in the diagrams above is very simplified and tends to overestimate the likely real exposure levels as it does not take account of the antenna radiation pattern. In practice, simplified or more complex diagrams may be used depending on regulatory or national practice approaches. It is important that the zones are clear to persons who may be using the diagrams.

#### 4.6 Compliance for wireless devices

Low power wireless devices include mobile phones, tablets, wireless sensors and supporting infrastructure such as wireless access points. In general, these devices will be designed and tested

for compliance by the manufacturer and no further action is required other than follow any installation or usage instructions provided by the manufacturer. The IEC has published technical standards to assess compliance of devices intended for use close to the ear (IEC 62209-1, 2005) and close to the body (IEC 62209-2, 2010). The device manufacturer should provide a copy of the compliance assessment and documentation on request. However, national requirements may differ.

#### 4.7 EMF compliance framework

A global EMF compliance framework is important in order to ensure the protection of the public and the workers from the adverse effects of EMF.

At the request of the International Advisory Committee (IAC) to the WHO's International EMF Project, the WHO has developed a Model Act and a Model Regulation that provide the legal framework to ensure this protection at the national level. An important aspect of this model legislation is that it uses international standards that limit EMF exposure of people (that is the ICNIRP exposure guidelines) and international standards for assessing the emissions of EMF from devices (IEC and IEEE device emission standards).

This Model Legislation follows the widely accepted practice among lawmakers of setting out an enabling Act that permits the responsible Minister or National Regulatory Agency to subsequently issue Regulations, Statutory Orders or Ordinances as appropriate, so as to deal with specific areas of concern. It comprises three main elements:

- A Model Act to enable an Authority to initiate regulations and statutes that limit the exposure of its population to electromagnetic fields in the frequency range from 0 Hz to 300 GHz.
- A Model Regulation which sets out in detail the scope, application, exposure limits and compliance procedures that are permitted under the Act, in order to limit people's exposure to electromagnetic fields (EMF).
- An Explanatory Memorandum describing the approach to the Act and its Regulations.

The WHO model legislation for EMF is available from the EMF Project website<sup>14</sup>.

The WHO advises that if a national authority wants to develop its own exposure limits, it should use or take into account the WHO Framework for Developing EMF Standards.

ITU supports the model legislation as an effective model to regulate EMF exposure, as the harmonized exposure level should be equal to all humans, disregarding race or borders.

#### 4.8 Compliance assessment

When a wireless access point or base station is installed, there should be an assessment of compliance with exposure limits. In order to allow for accurate and efficient assessments, different approaches can be implemented depending on the characteristic of the antenna and/or on the installation type. In some specific cases, compliance with relevant exposure limits can be assessed without the need of conducting measurements, for example, where low power is transmitted, or where the position/orientation of the transmitters/antennas makes compliance zones inaccessible to the general public or where simpler calculation methods can be used (Recommendation ITU-T K.52).

---

<sup>14</sup> <http://www.who.int/peh-emf/standards/en/>

Sophisticated calculation tools can be used where sufficient information is available on the transmitter and antenna characteristics, and the surrounding environment. Both broadband and frequency selective equipment can be used for the assessment (Recommendation ITU-T K.61). Measurements conducted with broadband equipment, however, might lead to overly conservative results. If the exposure level in areas accessible to the general public is found to be above the limits by means of broadband measurements, then compliance should be verified with frequency selective equipment. Otherwise, the mitigation techniques described in Recommendation ITU-T K.70 should be applied.

#### 4.9 Requirements for low power systems

Some types of wireless network infrastructure operate at very low power, and consequently they have small compliance zones or compliance zones contained within the equipment cover. These may be deployed in many locations as part of SSC infrastructure in order to provide widespread wireless connectivity. With the aim of reducing the administrative burden on city officials and providing an environment that fosters wireless connectivity, SSCs should develop simplified procedures for small, low-power antenna installations. Generally, the important parameters are: (a) the transmitter power, (b) antenna gain, and (c) the position of the antenna. Some small cell installations will produce similar exposures in nearby areas to higher power macrocell sites because the small cells may be positioned at lower heights and closer to people (Cooper *et al.*, 2006).

ITU-T Study Group 5 is developing technical specifications for simplified assessments of low power systems. In terms of guidance, transmitters of less than two watts EIRP do not require an EMF evaluation (Recommendation ITU-T K.52, 2004).

In some countries, low power radio systems may be assessed for compliance as a class of radio transmitters with defined installation (for example, height above public areas) and RF compliance (for example, maximum transmit power) requirements. In such a case, it may be sufficient to provide approval for all equipment of the same type subject to the specified requirement without reviewing individual installations. An example would be installing small cell base stations on street light poles where the equipment operator would be responsible for the details for each particular installation.

#### 4.10 Compliance for shared sites

There may be practical or radio coverage reasons for antennas sharing a site. Practical matters may include the availability of existing physical infrastructure, security and power. Radio coverage reasons may include height, proximity to an area where many users are located and avoiding obstructions from other objects and structures.

Where antennas are mounted near to one another, their transmission patterns may overlap to create a larger compliance zone than for the individual antennas. Operators of radio equipment at a shared site may need to exchange information about transmitter and antenna characteristics for RF compliance assessments to be completed.

Authorities and operators should discuss and agree on the framework for ensuring compliance of a shared site, both for the case of a new site that is to be shared, and the case of new equipment additions to an existing site.

## 5 EMF health and safety information

There are many sources available on EMF health and safety information. Understanding what information is available and being able to provide the most appropriate and suitable information to respond to the requirements of particular audiences is crucial.

ITU recommends EMF information from the WHO.

EMF information for consumers should be prepared in a format that is concise and easy to read. There are many sources of information available on the subject and quite often there is a tendency to provide too much information, which can lead to confusion and misunderstanding.

Information should be tailored to suit the specific requirements of the target audience. A layered or scaled approach is often very effective in communicating complex messages. The EMF Explained Series<sup>15</sup> has been developed by the ICT industry using a layered approach. Information on EMF Explained is sourced from national and international health agencies.

### 5.1 Compliance information

In many cases, ICT providers will only need to make available basic safety compliance details for the relevant product. This may consist of a compliance statement or compliance value. Where possible, this information includes a brief explanation of what the compliance value means, as well as a reference for further information.

Some governments require control measurements and publication of the results to show compliance with the RF-EMF. In areas of high social concern about EMF, one solution to these problems can be the control of the electromagnetic emissions by taking measurements and having a proper communication. Measurements turn emissions into something objective and, when presented to the public in an understandable format, help diminish the unawareness and helplessness of the public (Recommendation ITU-T K.83). Other approaches have also been used including operator declarations of compliance, measurements of random sample of sites and post-installation measurements of antennas (Recommendations ITU-T K.52; ITU-T K.61 and ITU-T K.70). Measurements and monitoring of environmental levels of radio signals from mobile and wireless networks consistently find levels that are small fractions of the ICNIRP public exposure limits. The WHO<sup>16</sup> reports that recent surveys have shown that the RF exposures from base stations range from 0.002% to 2% of the levels of international exposure guidelines, depending on a variety of factors such as the proximity to the antenna and the surrounding environment. This is lower or comparable to RF exposures from radio or television broadcast transmitters.

### 5.2 Health and safety information

Where health and safety information on EMF is required, the same principles apply in terms of using a format that is concise and easy to read. It is recommended to reference independent national and international health agencies like the WHO, which offers EMF fact sheets in a number of languages. In many cases, a brief summary on health may also be required and this should always reference or quote the information's source.

---

<sup>15</sup> <http://www.emfexplained.info/>

<sup>16</sup> <http://www.who.int/peh-emf/publications/facts/fs304/en/>

### 5.3 Sources of information

Sources of EMF information include:

**Table 2 – Selected sources for information on EMF topics**

Information	Source
EMF and health	WHO EMF Project - <a href="http://www.who.int/peh-emf/en/">http://www.who.int/peh-emf/en/</a> ICNIRP EMF documents - <a href="http://www.icnirp.org/PubEMF.htm">http://www.icnirp.org/PubEMF.htm</a>
ITU-T EMF information	ITU-T EMF - <a href="http://www.itu.int/en/ITU-T/emf/Pages/default.aspx">http://www.itu.int/en/ITU-T/emf/Pages/default.aspx</a>
ICT industry information	EMF Explained - <a href="http://www.emfexplained.info">www.emfexplained.info</a> SAR Tick - <a href="http://www.sar-tick.com">www.sar-tick.com</a>

## 6 Community information, consultation and engagement

While many stakeholders recognize the personal benefits of using ICT tools and mobile services, local officials and the public may have concerns about possible risks emerging from the radio signals used by antenna sites and ICT devices. These concerns may lead to delays in acquiring new antenna sites, to negative media stories and to heightened pressure on policymakers to adopt further restrictions, amongst others. Research conducted for the European Commission suggests the existence of low levels of public awareness in regard to the need for antenna sites, the operation of wireless devices and mobile phones, as well as the regulation and control of radio signals (Eurobarometer, 2010). The following aspects should be considered in order to increase that awareness, and to foster better-informed discussions and citizen engagement in this field.

### 6.1 Guidance on public participation and consultation

Recognizing the importance of effective communication, in 2002 the EMF Project of WHO produced a booklet on risk communication that contains the following definition (WHO, 2002):

*'RISK COMMUNICATION: An interactive process of exchange of information and opinion among individuals, groups and institutions. It involves multiple messages about the nature of risk and other messages, not strictly about risks, that express concerns, opinions, or reactions to risk messages, or to legal and institutional arrangements for risk management.'*

This definition suggests that risk communication is not only about presentation of scientific information about a given risk, but it also provides a forum for discussion on broader issues of ethical and social concern.

### 6.2 Why is consultation important?

Consultation and dialogue with communities is crucial in order to ensure that people who may have an interest or be affected by the deployment of new ICT technologies and systems are well informed. When a new development or technology appears in a town or local neighbourhood unexpectedly, local stakeholders can oppose it because they may feel offended or threatened by its appearance, or simply excluded from the process that led to its implementation.

If people feel that their personal well-being or that of their family is being negatively affected in some way, their opposition to the new development can turn to anger or frustration with those responsible.

In order to avoid such a situation, effective risk communication emphasizes the need to do the following:

- Build a working relationship with local stakeholders as a trustworthy and reliable party.
- Ensure transparent information management in order to address concerns, reduce public scepticism and make the issues more understandable to the broader public.
- Provide stakeholders with trusted sources of information, and/or foster a dialogue between the parties involved.
- Emphasize the community's benefits associated with improved mobile communications.
- Find ways of providing people with a sense of involvement in the project, in order to reduce their perception of being powerless.

### 6.3 Risk communication guidance

Risk perception is driven by individualization, dissolution of beliefs, social institutions and practices (Burgess, 2004). The WHO risk communication handbook is intended to support decision-makers faced with public controversy, scientific uncertainty, and the need to operate existing facilities and/or applications for new facilities (WHO, 2002). The handbook's goal is to improve the decision-making process by reducing misunderstandings and improving trust through better dialogue. When successfully implemented, community dialogue helps to establish a decision-making process that is open, consistent, fair and predictable. It can also help achieve the timely approval of new facilities, while protecting the health and safety of the community.

The mobile industry has also developed guidance on practical risk communication (GSMA and MMF, 2009).

## 7 Wireless ICT network infrastructure

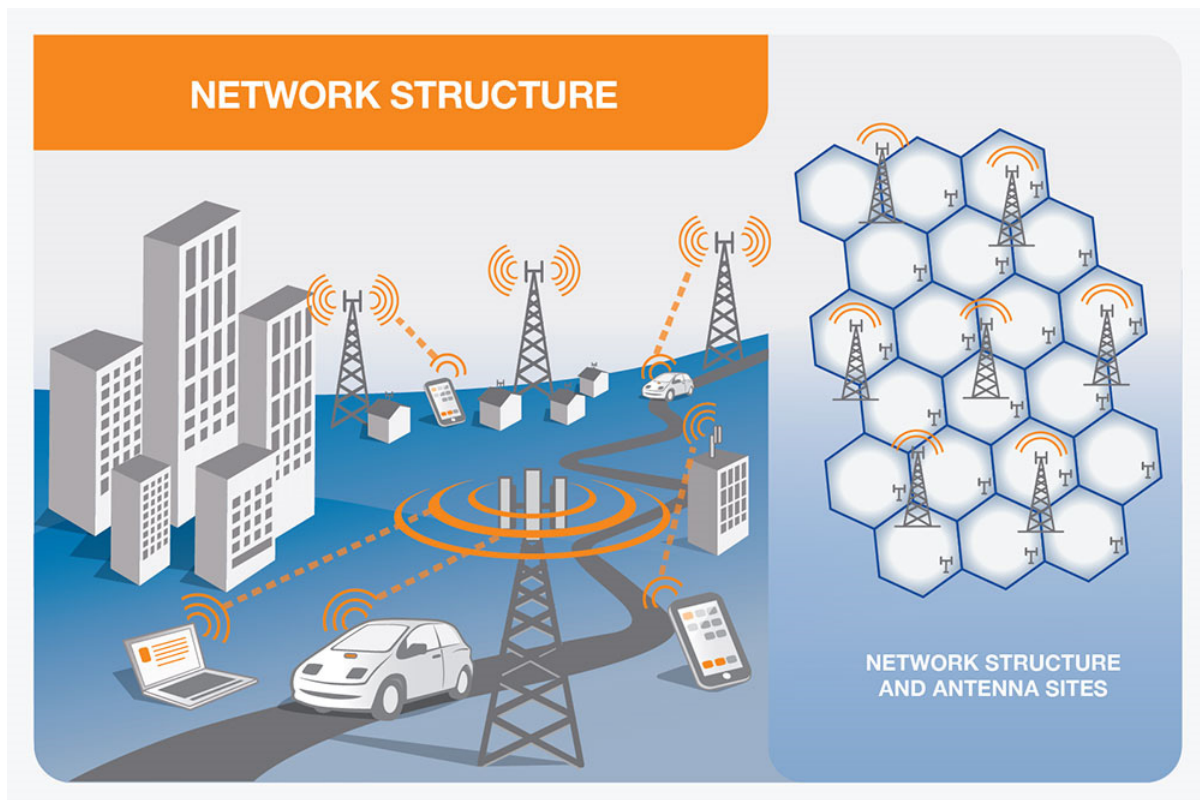
Wireless networks form the backbone of the ICT infrastructure that supports SSC. This section looks at the infrastructure elements of a wireless network in order to improve the understanding of the role played by the differing elements.

Wireless networks utilize various wireless technologies to connect ICT devices to a common platform or core network. In many cases, the ICT devices are connected through a core network to the Internet enabling global access and widespread interconnection.

### 7.1 Mobile network base stations and antennas

Mobile networks rely on a network of base stations that send and receive data from the ICT devices. Base stations need to be located close to users in order to improve efficiency by providing a good quality connection. Mobile devices use adaptive power control, and where the connection is good they will operate on the lowest power level needed to maintain a quality connection. A base station generally consists of an equipment cabinet with transmitters and receivers that are connected to external antennas mounted on a supporting structure. Figure 14 illustrates the distribution of a wireless network infrastructure and antennas in an urban area.





Source: Adapted from <http://www.gsma.com/publicpolicy/mobile-and-health/mobile-networks>

**Figure 14 – Example wireless network structure and antenna sites distributed across a city**

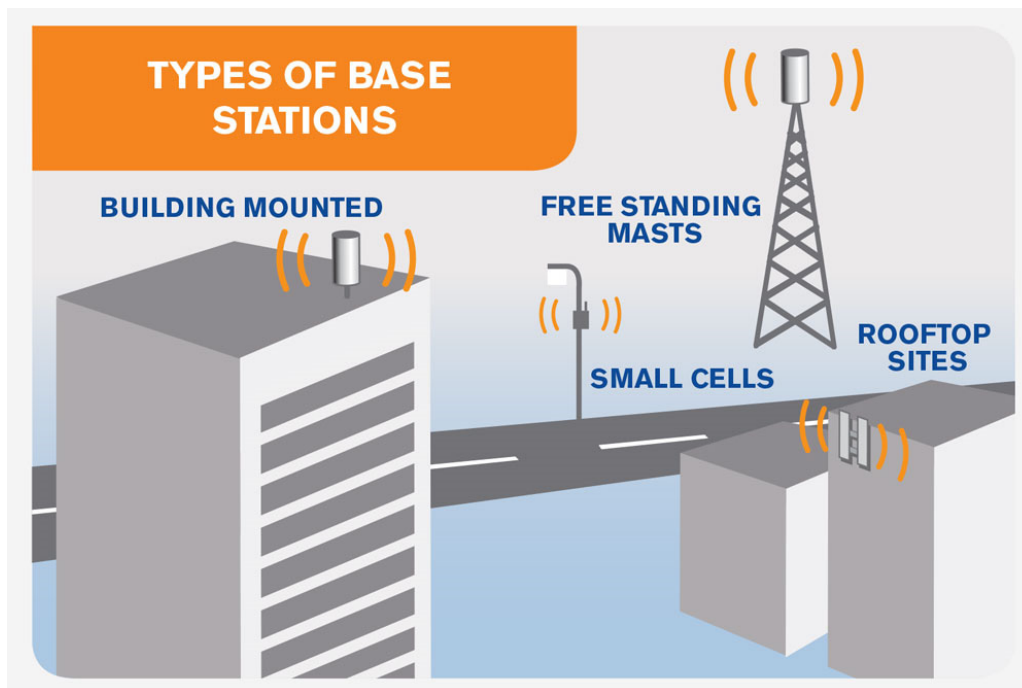
## 7.2 Macro base stations and small cells

Wireless base stations consist of various types of base stations depending primarily on the required coverage and service area. These types are represented in Figures 15 and 16, and explained below.

**Macro base station** – A macro base station utilizes antennas mounted on a tower, pole or building rooftop and typically covers a larger geographic area.

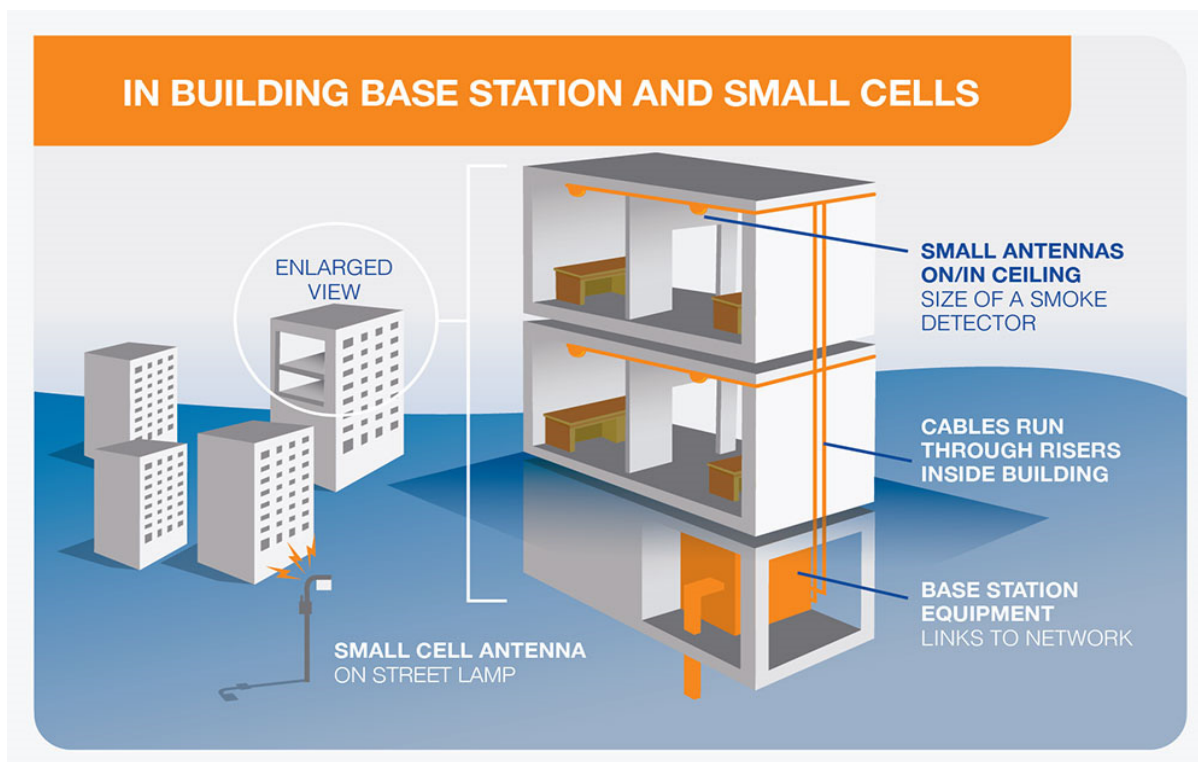
**Small cells** – Small cells are low power base stations or antenna systems installed close to mobile terminal users to improve capacity in a small geographic area. Depending on the transmitted power range, different terms can be used for small cells such as ‘medium range base stations’, ‘local area base stations’ or ‘home area base stations’ (see 3GPP TS 25.104 and TS 36.104). Small cells are sometimes also referred to as micro, picot or femto cells.

**In-building base station** – Small cell systems can be deployed inside buildings such as multi-storey office buildings, shopping centres, apartments, and underground railway systems by installing specially designed ‘in-building’ systems. These systems are sometimes referred to as distributed antenna systems (DAS) or small cell in-building coverage (IBC) and operate in a similar way to macro base stations but at much lower power levels.



Source: Adapted from <http://www.gsma.com/publicpolicy/new-gsma-animation-and-infographic-highlight-the-importance-of-mobile-networks-in-the-connected-world>

**Figure 15 – Small cell on street light and macro base station on building and tower**



Source: Adapted from Mobile Carriers Forum fact sheet 'The mobile phone network: In-Building coverage,' available at <http://www.mcf.amta.org.au/pages/Fact.Sheets>

**Figure 16 – In-building small cells or distributed antenna system to provide coverage throughout a building**

A dedicated in-building system usually consists of:

- Base station equipment, often located in a facilities' room or other service area;
- Cables which run from the base station through the building risers connecting the base station equipment to antennas; and
- Small antennas located on the ceilings or walls in strategic locations.

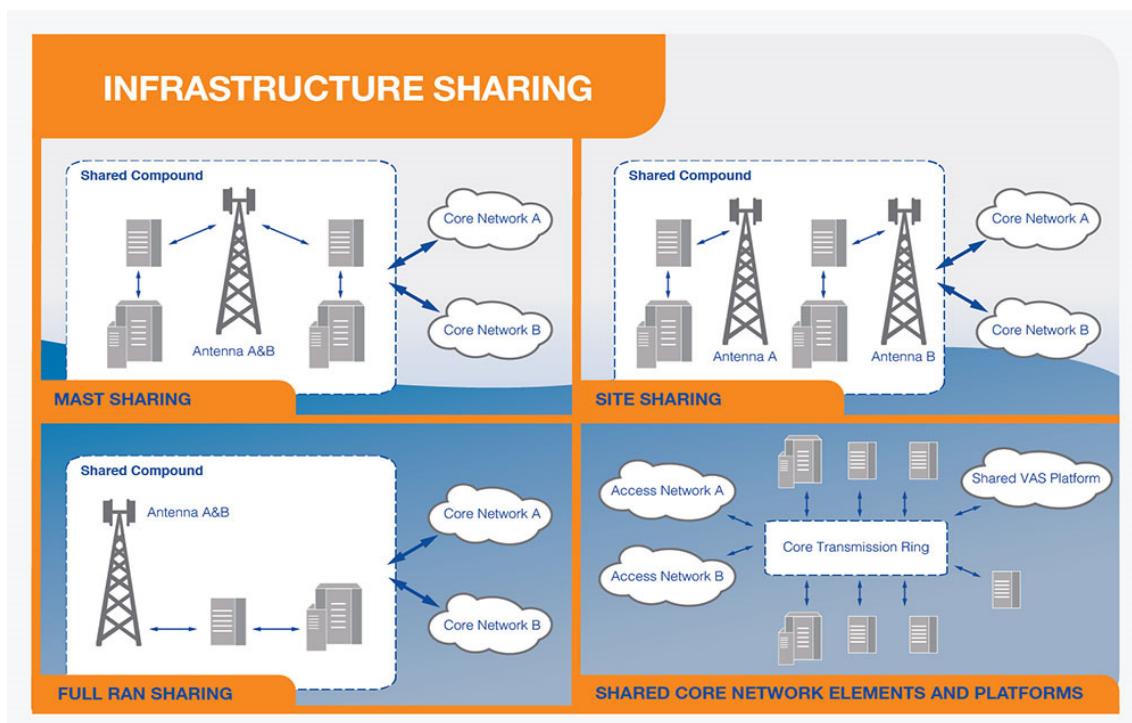
### 7.3 Sharing and co-location

There is an increasing trend for mobile network operators to adopt a variety of infrastructure models. This is being driven mainly by commercial and efficiency considerations, rather than by regulatory mandates. Sharing can also permit the co-location of SSC (for example, emergency communication networks) with the equipment of wireless network operators.

Infrastructure sharing may be passive or active:

1. Passive sharing includes site sharing, where operators use the same physical components but have different site masts, antennas, cabinets and backhaul. A common example is shared rooftop installations. Practical challenges include the availability of space and property rights. A second type of passive sharing is mast sharing, where the antennas of different operators are placed on the same mast or antenna frame, but the radio transmission equipment remains separate.
2. In active sharing, operators may share the radio access network (RAN) or the core network. The RAN sharing case may create operational and architectural challenges. For additional core sharing, operators also share the core functionality, demanding more efforts and alignments from operators. Again there may be issues of compatibility between the technology platforms used by the operators.

The different approaches to infrastructure sharing are illustrated in Figure 17.



Source: Adapted from GSMA, Mobile Infrastructure Sharing, (2008).

**Figure 17 – Main types of infrastructure sharing**

Infrastructure sharing has the potential to (GSMA, 2008):

- Lead to faster and wider roll-out of coverage into new and currently underserved geographical areas.
- Reduce the number of antenna sites.
- Reduce the energy and carbon footprint of mobile networks.
- Reduce the environmental impact of mobile infrastructure on landscape.
- Reduce costs for operators.
- Optimize the use of the RF spectrum and increase data speeds through active sharing of the frequencies.

In some cases, site sharing increases competition by giving operators access to key sites necessary to compete on quality of service and coverage, thus sharing improves roaming. Governments may also consider positive incentives to roll out into underserved areas.

In both passive and active sharing, it is necessary to consider the possible effects on RF exposure levels and compliance boundaries. As discussed in section 7.2, antennas that are close together or operating at higher powers may have overlapping compliance zones leading to a combined zone that is larger than the individual antenna zones. Antennas that are shared by more than one operator may have higher combined transmitter powers.

Nearby residents may think that a higher number of antennas in the surrounding areas will lead to higher exposure levels at the ground level in publicly accessible areas. Measurements undertaken in Germany demonstrated that neither distance to the antenna nor the number of visible antennas were accurate indicators of RF exposure. Instead, the orientation of the antenna's main lobe constitutes the main factor influencing exposure (Bornkessel *et al.*, 2007).

#### 7.4 Location of antennas and access restrictions

Wireless communication antennas should be positioned so that locations where the public exposure limits may be exceeded are not reasonably accessible to the general public. This can be achieved by selecting the location of the antenna or by the use of barriers to restrict access.

Low power antenna installations and wireless access points have no or limited positioning requirements. In addition, simple guidance may be provided by the operator or equipment manufacturer.

Higher power antennas are generally mounted above head height (sometimes on a short antenna mounting pole) or on the outer surface of buildings where it is not possible for the public to access areas in front of the antennas. Such antennas have directive antenna patterns that substantially decrease the exposure to directions above the horizon and to the ground near the antenna tower. When locating antennas, an assessment of the size of the EMF compliance zone should be conducted to determine whether the compliance zones could reach adjacent buildings. This could require a change in antenna position or reduction in transmitter power in order to ensure compliance with the EMF limits (Recommendation ITU-T K.70, 2007).

A number of options are available when considering the use of physical barriers to restrict access, namely:

- Rooftop access controls: This may include a locked ladder or rooftop door with permission required and information available for persons requiring access to the rooftop.
- Physical barriers: Non-metallic screens, fences or chains can be used to indicate areas that should not be entered by members of the public.

In some cases, painted lines may also be used to indicate compliance boundaries. However, their effectiveness depends on the awareness that exists among the persons that may access the area.

The building owner is often provided with information on how to arrange access for persons, such as maintenance personnel, who may need to work in areas close to or in front of the antennas.

## 7.5 Signage

In general, signage requirements should be appropriate for the technical parameters of the wireless equipment/antenna and the accessibility of the site.








Low power installations where the compliance zone is within the equipment will generally not require signage.

For other installations, signs should be placed near the compliance zone boundaries. The IEEE Recommended Practice for Radio Frequency Safety Programs, 3 kHz to 300 GHz, provides guidance on the installation of signs (C95.7-2005). Depending on the region, RF-EMF safety signs may require multiple languages to ensure understanding. Some examples of signs and where they may be used are provided in Table 3.



**Table 3 – Guidance on use of RF warnings signs**

(Adapted from (C95.7-2005) and (C95.2-1999))

Sign	Guidance on use	Example - Australia	Example - USA
Notice	Used to alert persons to the potential of exposures exceeding the reference levels for the public. Note: In some countries, these signs are called Notices or Caution Signs		
Caution	Used to alert persons to the possibility of exposures exceeding the reference levels for workers. Note: In some countries, these signs are called Caution Signs or Warning Signs		
Warning	Used to advise persons of potential exposures that may exceed the reference levels for workers by a factor of 10 (the safety factor in the (ICNIRP, 1998) guidelines. Note: Not used in all countries.	Not used in Australia	
Danger	Normally only used for situations in which immediate and serious injury will occur such as in the case of RF burns and/or RF electrical shocks.		

Other signage, such as advertising, should not generally be attached to wireless network antennas unless it is part of the integration of the antennas with the visual environment (see section 9.6). Other general requirements for signage can be found in the European Directives 2013/35/EU and 92/58/EEC.



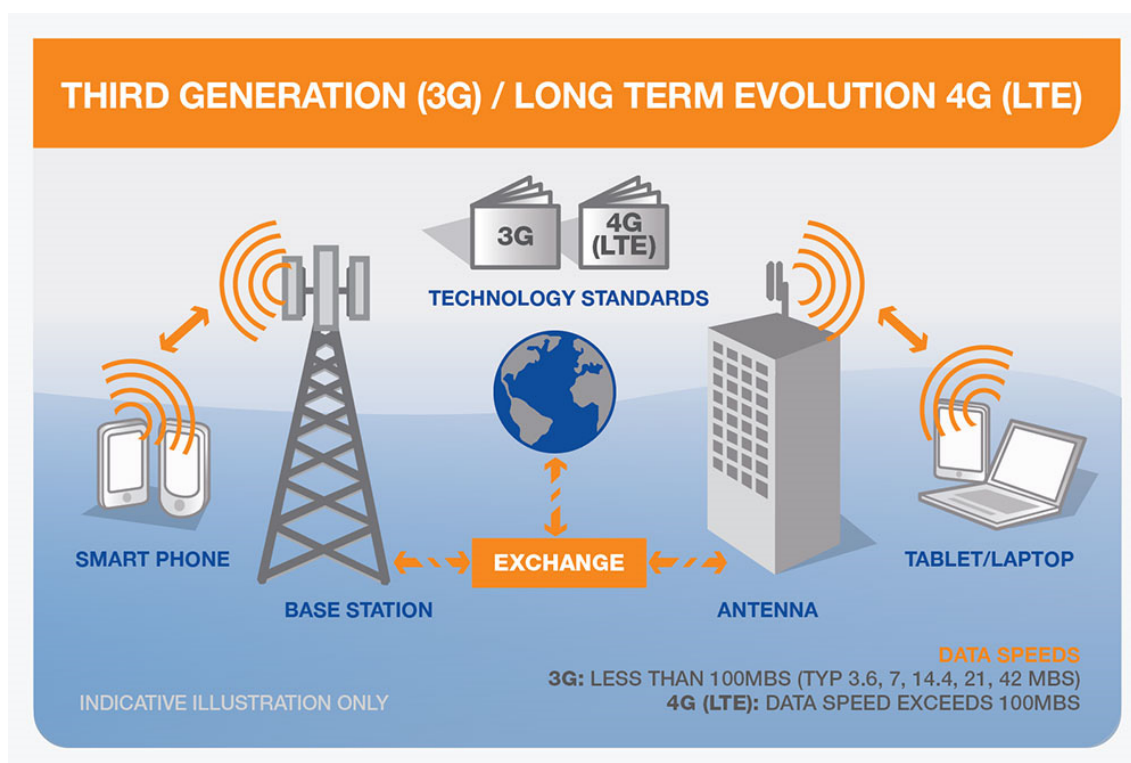
## 8 ICT wireless technologies

Wireless technologies used by ICT systems include cellular and mobile technologies, Wi-Fi, WiMax, Bluetooth, DECT, ZigBee and Wireless M-Bus.

This section provides a summary of some of the wireless technologies used by the ICT systems.

### 8.1 Mobile network technologies – 3G and 4G

4G LTE (Long-term evolution) is the latest major enhancement to mobile radio communications networks. LTE is a standard that is part of the evolution of 3G, which incorporates significantly increased data rates (for the same transmitted power) and better performance to enhance the mobile broadband experience. It should be noted that this improved level of service can be achieved without increasing the output power of the transmitters. The functioning of 3G and 4G technology is illustrated in Figure 18.



Source: Adapted from EMF Explained, available at <http://www.emfexplained.info/?Page=25196>

**Figure 18 – 3G and 4G technology**

## 8.2 WiMAX

The worldwide interoperability for microwave access (WiMAX) is a telecommunications technology aimed at providing wireless data over long distances in a variety of ways. Products are based on the Institute of Electrical and Electronics Engineers (IEEE) 802.16 standards. WiMAX provides an alternative Internet wireless access technology to broadband cables and digital subscriber lines (DSL). WiMAX networks enable a variety of options for broadband connections, essentially constituting a larger version of a Wi-Fi network (Figure 19).

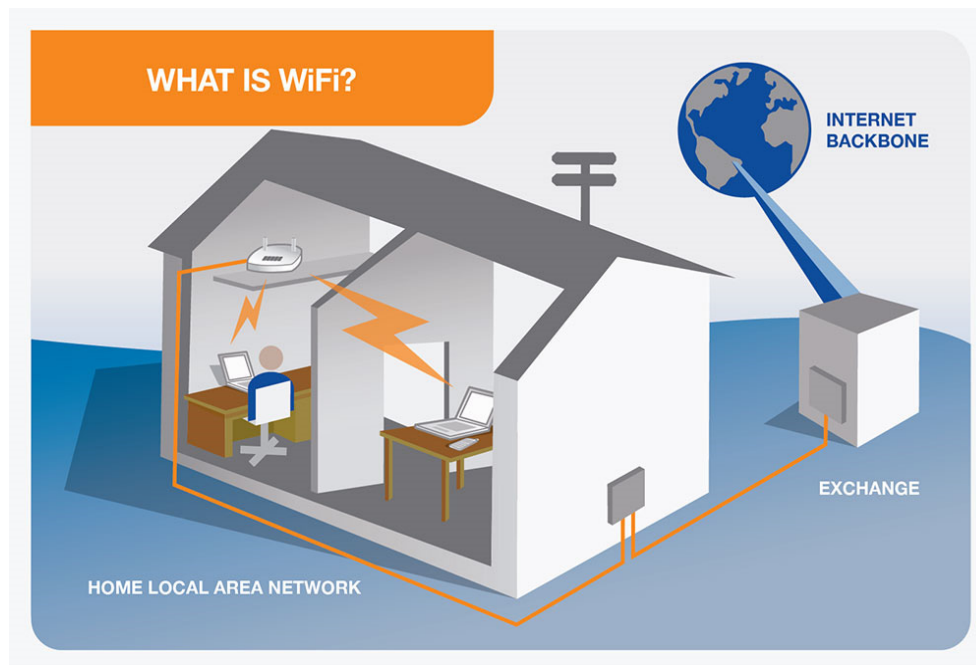


Source: Adapted from EMF Explained, available at <http://www.emfexplained.info/?ID=25133>

**Figure 19 – Illustration of a WiMAX network**

### 8.3 Wi-Fi

Wi-Fi is the term used to describe high speed wireless network connections over short distances between mobile computing devices such as laptops and the Internet (Figure 20). These are sometimes termed wireless local area networks (WLANs) and refer to products that are based on the Institute of Electrical and Electronics Engineers (IEEE) 802.11 standards.



Source: Adapted from EMF Explained, available at <http://www.emfexplained.info/?Page=24788>

**Figure 20 – Illustration of a Wi-Fi modem connected to laptops in a home**

### 8.4 Mobile backhaul and radio relays

A critical aspect to selecting new sites for ICT base stations is the availability of a connection back to the core or main network. This is often referred to as ‘backhaul’ or ‘transmission’. As the demand for data intensive mobile services such as video increases, the capacity of the backhaul data connection will also need to grow. The capacity needed per base station site will differ substantially, depending on target data rates and population density. Ericsson (2014) forecasts that in 2019, high capacity base stations are expected (in the more advanced mobile broadband networks) to require backhaul in the 1 Gbit/s range, whereas low capacity base stations are expected to require backhaul in the 100 Mbit/s range.

Microwave and optical fibre are major transmission media technologies and are the best suited to meeting these capacity requirements. Optical fibre transmission will increase its share of the mobile backhaul market and it is projected to connect more than 40% of base stations by 2019. Today, microwave dominates the market for transmission technologies for mobile backhaul worldwide, connecting 60% of all base stations.

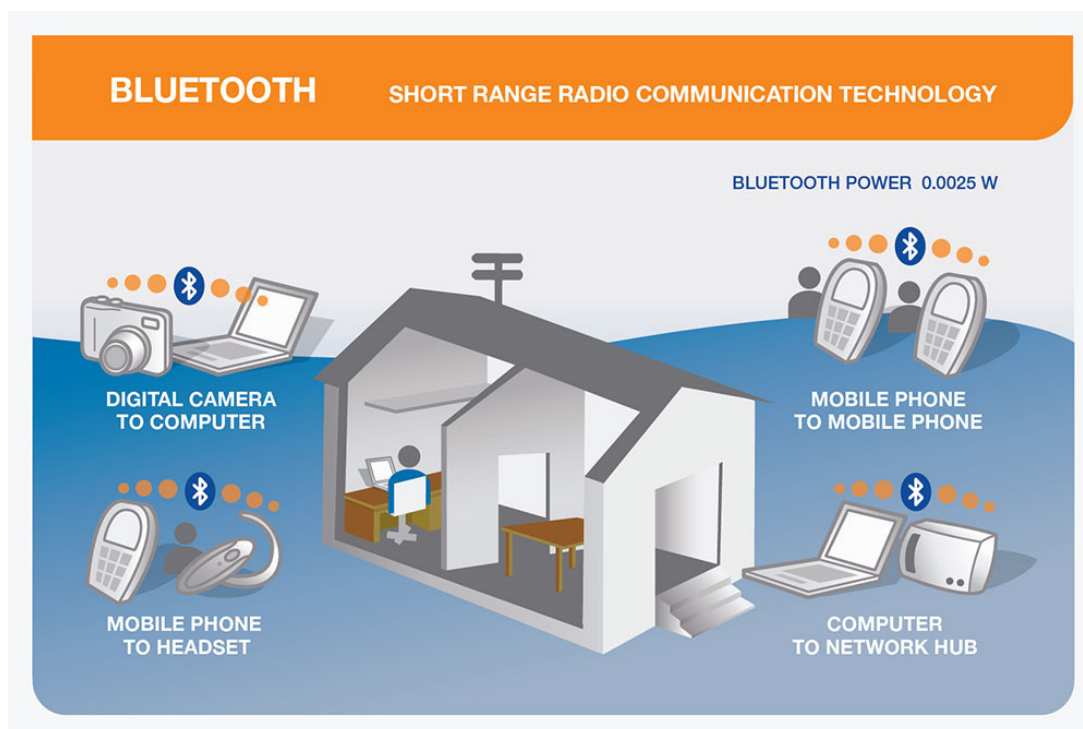
Some distributed and short-range wireless technologies (for example, Wi-Fi, Bluetooth, Wireless M-Bus and Zig-bee) may be able to operate with lower speed backhaul, such as x-type digital subscriber line (xDSL) (or even slower means), in the case of applications that do not require high data rates.

An existing building in a community is more likely to have a network connection at the building or in a very close proximity, compared to establishing a new site. In this last case, the backhaul would

need to be designed and constructed as a separate project and in many cases may prove not to be feasible, for example, on the top of a mountain or a hill.

### 8.5 Bluetooth

Bluetooth wireless technology is a short-range radio technology that uses radio frequency fields to transmit signals over short distances between telephones, computers and other devices. The technology offers simplified communication and synchronization between devices without the need for cables. An illustration of these connections is provided in Figure 21.

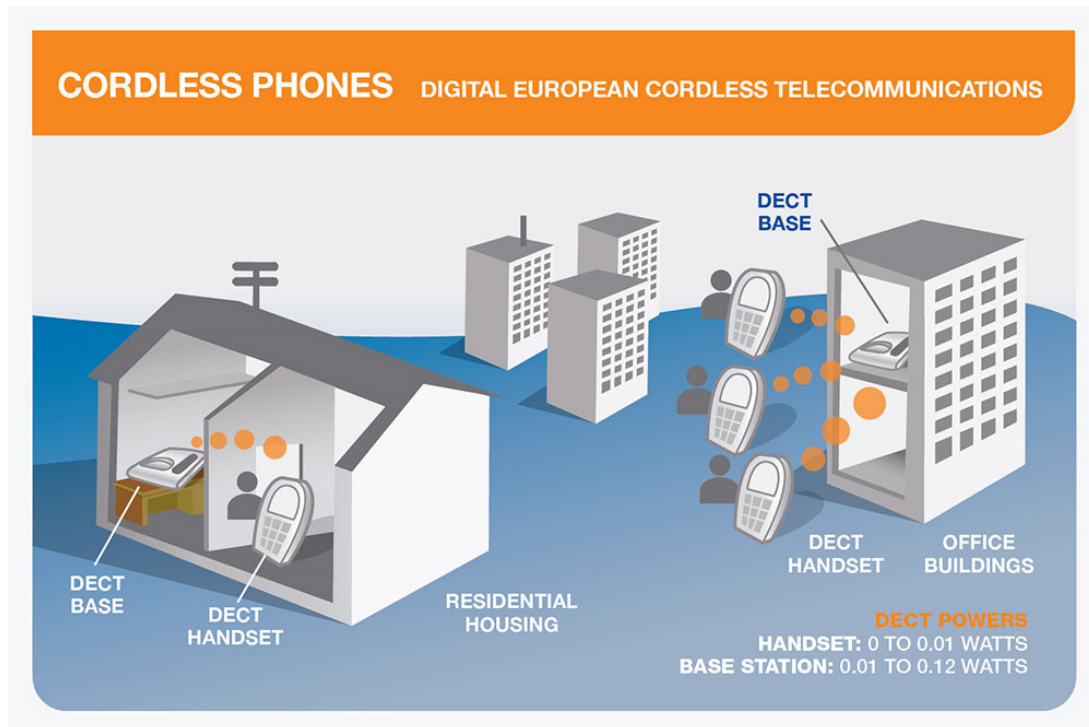


Source: Adapted from EMF Explained, available at <http://www.emfexplained.info/?Page=25530>

**Figure 21 – Illustration of Bluetooth connections**

## 8.6 DECT

DECT stands for digital enhanced cordless telecommunication. DECT is a common standard for digital cordless telephones and consists of a radio technology suited for voice, data and networking applications in residential, corporate and public environments (Figure 22). Many cordless phones used in residential homes use DECT technology.



Source: Adapted from EMF Explained, available at <http://www.emfexplained.info/?Page=25533>

**Figure 22 – DECT cordless phone systems in homes and office buildings**

## 9 ICT antenna siting approval requirements

Public wireless communications and ICT systems are critical national infrastructure for today's society and their role is particularly evident in the event of emergencies and disasters. Consistent planning rules for ICT infrastructure are critical for the efficient deployment and operation of ICT systems. Fragmented planning authority rules may delay network deployments and may lead to ICT systems not functioning properly and/or providing intermittent service, which in some cases (for example, medical cases) may be life threatening.

### 9.1 Antenna permit procedures

Standardized antenna permit procedures will reduce the administrative burden on both authorities and operators of wireless infrastructure. It is helpful if the procedures are harmonized nationally, considering that wireless infrastructure is deployed at the local level to provide national and international connectivity.

RF exposure limits and compliance procedures should be adopted nationally based on international human exposure recommendations and technical compliance standards. National policy for wireless infrastructure should contain a statement to the effect that compliance with RF-EMF exposure limits is sufficient to address concerns about possible health hazards.

SSC should avoid policies such as restrictive RF exposure limits or planning exclusion zones that increase public concern and that can negatively impact deployment.

Siting rules should also take into account the physical characteristics of the wireless network equipment. Generally, the requirements needed to obtain approvals increase according to the size of the proposed base station. Under these rules, small installations such as small cells or other small antenna installations on existing physical infrastructure may require no local authority approvals, while macro base stations may be subject to the full planning process.

The radiocommunication companies must avoid the installation of base stations without having fulfilled the requirements set by the relevant authorities (at the national, provincial and municipal levels).

At the same time, procedures should be developed in consultation with the operators of wireless infrastructure.

The following sections provide further guidance on these matters based on international good practices.

### 9.1.1 Small cells

The wireless infrastructure for SSC will increasingly rely on small cell installations for wireless services. This may take the form of Internet access via Wi-Fi or mobile communication systems. Small cell systems can provide higher data rates or coverage in areas that are difficult to reach by macro cell solutions, for example, shopping centres, train stations and sporting stadiums.

Recommendation ITU-T K.100 has developed criteria for the EMF compliance assessment of base stations including small cells. It is expected that small cells transmitting below a specified power will be deemed to comply with RF exposure limits without the need for further assessment.

### 9.1.2 Information requirements

The information requirements should focus on providing the information needed to strengthen decision-making processes. Examples of topics that may be included are:

- a) a proposed location of the wireless infrastructure;
- b) a written description of the proposed work;
- c) a statement of compliance with RF-EMF exposure limits;
- d) a confirmation of the agreement reached, in principle, with the landlord of the proposed location;
- e) a statement identifying if the site is designed to use simplified procedures based on low-power, small-size, modification to existing site, or other factors as defined in national rules; and
- f) a statement that the authority may obtain further information on the proposed wireless infrastructure, including contact details of the information provider.

In particular locations, such as heritage areas, additional design information may be required to evaluate the application.

### 9.1.3 Notification and consultation requirements

There may be differing levels of stakeholder interest in wireless antenna siting proposals due to the characteristics of the wireless infrastructure or the proximity to community facilities. Notification, consultation and dialogue requirements should be standardized for effective communication with the stakeholders.



- **Notification** for the majority of sites may be limited to the landowner, the local authority, affected public utilities and others as required by national regulations. It is helpful if the notification can be standardized nationally both within and between network operators as this is less confusing to potential landlords and local authorities. Notification by poster or letter might be an appropriate means in some locations. Notification constitutes a form of basic information provision, a one-way communication approach.
- **Consultation** might be sensible for locations with the potential for public opposition, such as community facilities, locations with high amenity value or for sites with potentially high perceived impact. This could mean a longer period of notification, allowing time to resolve any issues with landowners and neighbours through more careful design, location choice and potential flexibility in the implementation. Consultation by letter, telephone or through meetings could be appropriate in locations where some opposition is expected either regarding planning and environmental issues or due to community concerns. Consultation constitutes a two-way information exchange between the operator and the key stakeholders.
- **Dialogue** might be necessary for environmentally sensitive areas or locations with complex concerns such as schools or hospitals or locations where protests have previously taken place. Prior discussions can be undertaken with landowners, neighbours, local authorities and other stakeholders in order to develop agreements in advance of full deployment. This will require a longer lead time in order to reduce or remove potential delays to deployment. Dialogue should be considered for sites where a high level of community concern is anticipated or where they could potentially escalate. This is a planned communication process aimed at building trust and avoiding large-scale public events and media campaigns. Dialogue constitutes a multiple exchange of information between governments, operators and a broad set of interested stakeholders.

#### 9.1.4 Modifications to existing sites

Planning regulations should encourage the use of existing base station facilities for network upgrades, modifications and deployment of additional ICT systems where feasible by providing for faster decision-making and simplified procedures. Modifications to existing sites need to ensure that the site remains compliant with EMF exposure limits.

Simplified procedures for physical modifications should also be considered. In the USA, section 6409(a) of the Middle Class Tax Relief and Job Creation Act of 2012 provides that the State or local government “may not deny, and shall approve” any application for collocation, removal, or modification of equipment on wireless tower or base station that does not substantially change the physical dimensions of a tower or base station. The Federal Communications Commission (FCC) has previously defined “substantial increase in size” in the Nationwide Collocation Agreement, 47 C.F.R. Part 1, Appendix B, as follows:

- Increase in tower height by more than 10% or height of additional antenna array plus 20 feet (approximately 6 m), whichever is greater;
- More than four new equipment cabinets or one new shelter;
- Protrusion of more than 20 feet (approximately 6 m) or width of tower, whichever is greater;
- Excavation outside existing leased or owned property and current easements.

As another example, New Zealand provides for simplified procedures where a replacement pole does not have a diameter greater than 50% of the original structure and height increase the lesser of three metres or 10% (Ministry of the Environment, 2009). Other jurisdictions have similar

provisions for modifications to existing sites. An overview of base station planning requirements in Europe may be found on the GSMA website<sup>17</sup>.

### 9.1.5 Decision periods

The procedures for antenna permits should specify the timelines in place for decisions to be made. These should generally be similar to those for other similar types of physical infrastructure.

Some countries have adopted specific decision periods for wireless network antenna site proposals. In a ruling known as the ‘shot-clock’ rule, the USA FCC specifies that decisions must be made within 90 days for co-location requests at an existing site and within 150 days for new sites. In case of delays, the antenna operator can seek legal review. For some developments in England and Wales (for example, ground based masts below 15 m and some rooftop developments), the authority must make a decision within 56 days. If no decision is made, the operator can proceed on the basis that the lack of response is a consent.

In no case should operators install antennas without meeting prior specific approval procedures of the corresponding national, regional or municipal authority, as this will increase public concerns in regards to antenna installations.

### 9.1.6 Independent appeals process

In some cases, members of the community or the antenna operator may not be satisfied with the authority’s decision. A clear process should be defined for appeals to an independent authority as well as the grounds to appeal. It is important for all parties that the decision-making process is fair, transparent and free from political influence. In some countries, judicial review of local authority decisions is possible. In other countries, there are separate environment courts or the appeal may be made to a relevant ministry.

In Australia, New Zealand, the UK, and the USA courts have generally concluded that compliance with national RF-EMF limits is sufficient to address health concerns (Dolan *et al.*, 2009).

## 9.2 Environmental impact assessment

This Technical Report limits the discussion of the environmental impact assessment to matters related to the siting of the wireless network infrastructure. This section is based largely on the New Zealand Ministry of the Environment’s ‘National Environmental Standards for Telecommunication Facilities: Users’ Guide’ (Ministry of the Environment, 2009). This is a binding regulation and replaces certain rules in district plans and by-laws that affect the activities of telecommunications operators. Every local authority and consent authority in New Zealand must observe national environmental standards and must enforce the observance of national environmental standards to the extent their powers enable them to do so.

Environmental impact assessment for telecommunication facilities may include:

- assessment of compliance with national RF-EMF exposure limits in areas that are reasonably accessible to the public;
- consideration of protection of vegetation, and historic, amenity and coastal areas;
- procedures for change of antennas and modifications to existing utility structures;
- restrictions on the size and location of telecommunication cabinets;

---

<sup>17</sup> <http://www.gsma.com/publicpolicy/mobile-and-health/base-station-planning-permission-in-europe>

- compliance with noise limits for telecommunication cabinets, air conditioning equipment and diesel generators;
- consideration of visual effects of proposed wireless network equipment.

Wireless network equipment generally presents a low environmental impact, and therefore requirements in this area should be proportionate and reasonable.

### 9.3 Schools, hospitals and similar community facilities

It is recognized that there may be community concerns or specific requirements for siting of wireless infrastructure near specific facilities.

In regard to schools, hospitals, elderly care and similar facilities, Recommendation ITU-T K.91( 2012) states that with respect to human exposure there are currently no technical requirements for any special consideration for locating base stations close to areas such as hospitals and schools. This is due to the fact that existing exposure guidelines incorporate safety margins in the exposure limits which are applicable to all locations. It also notes that good reception will result in lower transmitting power for customer devices and, therefore, in lower exposure to the end user.

In the case of hospitals, there may be electromagnetic compatibility (EMC) questions related to hospital equipment and wireless network infrastructure. ISO/TR 21730 (2007) provides guidance on the use of mobile wireless communication and computing technology in health care facilities including recommendations for electromagnetic compatibility with medical devices.

This guidance states the following:

*'RF emissions from in-building system network antennas (WAN microcells or repeaters, LAN access points) are most appropriately managed by locating them in a place where separation distance mitigates medical device EMI effects, such as the roof of corridors and rooms.*

*RF emissions from base station sites physically located on healthcare facility roof-top or building structures should conform to existing national radio regulations to limit emissions directly into the supporting building structure.'* (p. 14)

Most studies of interference have used mobile phones and other wireless equipment close to pacemakers or other medical devices (Calcagnini *et al.*, 2011; Iskra *et al.*, 2007; Morrissey, 2004; Tang *et al.*, 2009; van der Togt *et al.*, 2008). They have generally reported no interference at separations greater than 1 to 2 m between the phone and the medical device. The separation is in the order of 15-20 cm for mobile phones and pacemakers. As indoor wireless networks typically operate on similar powers to mobile phones, provided the antenna installation is ceiling or wall mounted, interference is unlikely to occur.

Provided that the potential EMC issues are addressed, there is no reason to restrict the siting of the antennas. In addition, measurements reported for femtocells indicate that mobile devices will operate at lower power levels thereby reducing the risk of interference and resulting in lower exposure from mobile devices (Boursianis *et al.*, 2012; Zarikoff *et al.*, 2013).

### 9.4 Access to public buildings and land

With the rapid growth and expansion of ICT systems, wireless networks need to maintain coverage and service in order to meet community and service demand.

The use of existing public buildings, infrastructure and land to locate wireless network base stations can provide an ideal solution to finding new suitable locations particularly in well-established communities and residential areas where the ICT systems are required. This approach could also

help to protect open spaces. The Broadband Deployment on Federal Property Working Group<sup>18</sup> was established in June 2012 by the United States President in order to develop and implement a strategy to facilitate the timely and efficient deployment of broadband facilities on Federal lands, buildings, and rights of way, federally assisted highways, and tribal lands. Countries like Mexico have launched similar initiatives.

### 9.5 Planning exclusion zones

In the context of wireless communications, infrastructure deployment planning-based exclusion zones (also known as 'Buffer Zones' or 'Cordon Sanitaires') are geographic areas generally imposed by some local governments and their agencies around community facilities where a base station cannot be established. These areas are generally distance-based and are applied without regard for the nature, or operation of radio base stations, or existing sources of RF-EMF exposure in the environment.

Typically, exclusion zones are imposed by some government policymakers in residential areas around community facilities such as primary and secondary schools, pre-schools or medical facilities including hospitals. However, there is no science-based rationale for their introduction, the specified facilities or the zone size (NRPB, 2004).

As the availability of mobile networks can contribute to save lives (for example, in the case of accidents, disasters, etc.), exclusion zones should be minimized (Chapman *et al.*, 1998; Wu *et al.*, 2012). A policy of planning-based exclusion zones has the potential to impact significantly upon the siting and deployment of wireless communications infrastructure. In turn, this impacts the delivery of quality wireless services (including mobile broadband) to consumers that increasingly rely upon these services. Operators usually have to increase the transmit power in nearby base stations to fulfil the service requirements.

A case study, based on the city of Melbourne, Australia, explored the effects of implementing a hypothetical 500 m exclusion zone policy around community facilities (schools, pre-schools and medical facilities) to a large urban area (Evans Planning, 2012). The study found that across the full metropolitan area, 54.1% of all existing radio base stations would be impacted. For an inner urban suburb, an exclusion zone of 500 m around all community facilities would cover 87.5% of the total geographic area of the suburb, affecting virtually all of the existing antenna sites.

Overall, the existence of multiple negative consequences suggests that distance-based planning exclusion zones are not an effective response to community concerns related to wireless infrastructure siting. SSC should not apply unscientific planning exclusion zones affecting wireless network infrastructure.

Some countries, such as Israel, prohibit or restrict the siting of base stations in nature reserves in order to preserve the aesthetics of the natural environment and avoid disruption due to construction activities. In the United Kingdom, a joint accord between National Parks England and the Mobile Operators Association was signed in July 2014. The accord aims to help communities living in national parks to benefit from consistent high quality connectivity and protect the special qualities of the National Parks by minimizing any adverse environmental impacts.

There are no indications that specific siting requirements are needed for wireless network equipment sited near petrol stations.

---

<sup>18</sup> <http://www.whitehouse.gov/the-press-office/2012/06/14/executive-order-accelerating-broadband-infrastructure-deployment>

## 9.6 Visual integration with the environment

Similar to all forms of development, wireless network equipment may have a visual effect. This visual effect can be attributed to two unavoidable characteristics of wireless network equipment:

- a) They are structures which generally protrude from other structures; and
- b) They need to be located at suitable heights in order to operate effectively.

These characteristics mean that wireless network equipment may be, and often is, highly visible in both urban and rural landscapes. The visual effect of wireless network equipment may be addressed by:

- a) Undertaking a detailed assessment of the landscape in which the wireless network equipment is to be located; and
- b) Designing the facility to respond appropriately to this landscape setting.

In this way, the wireless network equipment can be designed in a manner that is compatible with the particular landscape setting. The higher the level of compatibility of the wireless network equipment design with the landscape, the less significant or intrusive the visual effect will be. Understanding the contextual setting is paramount to developing a design response that is both appropriate and compatible.

Whilst reducing the visual effect is a very important objective, other factors may have a substantial bearing on the final outcome. It should be recognized that not all wireless network equipment will be able to achieve the best visual outcome. Some of the issues which often need to be considered in parallel with visual integration include:

- availability and suitability of land;
- any reasonable requirements of the landlord;
- radio frequency performance;
- impact on other facilities located at the same site;
- noise – usually from air conditioners and/or diesel generators;
- access for maintenance purposes;
- installation time frames and availability of materials;
- construction issues – structural and loading feasibility;
- cost;
- compliance with relevant and applicable national RF exposure standards; and
- co-location and site sharing opportunities.

Key principles for design and siting with improved visual integration include:

- colour relative to surroundings;
- texture relative to existing materials;
- form in regard to height, shape and position;
- bulk and scale relative to the local environment;
- design in harmony with the surroundings;
- ability to integrate with existing wireless network equipment;
- local landmarks, cultural or historical centres, viewpoints; and
- use of surrounding vegetation for screening ground level equipment shelters.

It should be noted that in some cases efforts to reduce the visual effect of the wireless network equipment have been criticized as a form of concealment of potential health risks. Therefore, dialogue and openness should be ensured from the early stages of the process in order to address these concerns.

### 9.7 Environmental impact assessment

This Technical Report limits the discussion of the environmental impact assessment to matters related to the siting of wireless network infrastructure. This section is based largely on the New Zealand Ministry of the Environment's 'National Environmental Standards for Telecommunication Facilities: Users' Guide' (Ministry of the Environment, 2009). This is a binding regulation and replaces certain rules in district plans and bylaws that affect the activities of telecommunications operators. Every local authority and consent authority in New Zealand must observe national environmental standards and must enforce the observance of national environmental standards to the extent their powers enable them to do so.

Environmental impact assessment for telecommunication facilities may include:

- assessment of compliance with national RF-EMF exposure limits in areas that are reasonably accessible to the public;
- consideration for the protection of vegetation, and historic, amenity and coastal areas;
- procedures for change of antennas and modifications to existing utility structures;
- restrictions on the size and location of telecommunication cabinets;
- compliance with noise limits for telecommunication cabinets, air conditioning equipment and diesel generators;
- consideration of visual effects of proposed wireless network equipment.

Wireless network equipment generally presents a low environmental impact, and therefore requirements in this area should be proportionate and reasonable.

## 10 Conclusions

Wireless and wired networks provide the underlying connections that underpin smart sustainable cities. Efficient deployment of wireless infrastructure will reduce the transmitted RF power in providing services and support greater efficiency for ICTs.

The design and deployment of wireless networks must also ensure compliance with the required quality of service as well as with standards and regulations on human exposure to radio frequency (RF) electromagnetic fields.

Wireless and wired access technologies are used to support SSC applications such as smart meters, remote health care, and smart transportation and education. Availability of connectivity is essential to the operation of these services which in turn deliver environmental benefits, improved quality of life and reductions in operating costs.

A range of different wireless technologies are used to support the ICT applications of SSC. The choice of a particular technology is influenced by factors such as range and data rate requirements. Short range wireless technologies include Bluetooth; medium range includes Wi-Fi; and longer range includes mobile technologies such as 2G, 3G and LTE. Each technology will have its own specific requirements in relation to the siting of wireless network infrastructure. However, in all cases shorter operating distances allow for lower powers for both the wireless network and the SSC application.



In some cases, the public may be concerned about possible health risks from exposures to the radio signals. It is important that SSC policies for EMF exposures follow the science-based recommendations of WHO and ITU. International EMF exposure guidelines have been developed by ICNIRP to protect all persons from all established health risks. It is recommended that national governments base their EMF exposure limits on the ICNIRP exposure guidelines and that SSC adopt the same requirements. Operators and manufacturers of wireless technologies should ensure compliance with these limit values. ITU and IEC have developed technical standards that can be used for compliance assessments through calculations or measurements. The compliance assessment policies should follow the ITU-T Recommendations.

SSC should adopt standardized antenna permit procedures as this will reduce the administrative burden on both authorities and operators of wireless infrastructure. These permitting procedures should be harmonized nationally to the largest extent possible and specify decision periods, information requirements and include simplified procedures for matters such as installation of small cells and modifications to existing sites. SSC can also promote an efficient deployment by providing access to government building and lands. SSC should avoid policies, such as restrictive RF exposure limits or planning exclusion zones, that increase public concern and that can negatively impact deployment. In regard to community facilities, Recommendation ITU K.91 (2012) states that with respect to human exposure there are currently no technical requirements for any special consideration when locating base stations close to areas such as hospitals and schools.

Siting rules should take into account the physical characteristics of the wireless network equipment. In general, the requirements needed to obtain approvals increase according to the size of the proposed radio base station. Physical installations of wireless equipment should consider the surrounding environment and aim for visual integration. Whilst reducing the visual effect is a very important objective, other factors may have a substantial bearing on the final outcome. Higher data rate applications may require backhaul data connections by optical fibres, whereas in other cases radio links may be sufficient. In all cases, power and access for maintenance are critical considerations in wireless equipment siting. The position of antennas should also take into account the orientation and size of EMF compliance zones. Appropriate signage can be used to inform persons accessing areas near to antennas of safe working procedures.

SSC officials, ICT industry and other stakeholders should base communications on reliable sources such as the ITU and WHO publications. Good risk communication practice and community engagement can reduce public concerns about EMF. Specific groups, such as workers that service or work with wireless ICT devices and equipment, may require EMF safety training.

Having acknowledged the importance of good practices in the deployment of wireless ICT technologies and services for the efficient operation of SSC the 'Smart Sustainability City EMF Check-list' (Annex 1) has been developed as a guide for policy and decision-makers. It is recommended that city officials and planners apply the 'Smart Sustainability City EMF Check-list' to ensure that SSC wireless ICT operates efficiently, and in compliance with EMF exposure standards.

## Bibliography

3 GPP TS 25.104

3 GP TS 36 104

Bornkessel, C., Schubert, M., Wuschek, M., and Schmidt, P. (2007), *Determination of the General Public Exposure around GSM and UMTS Base Stations*, Radiation Protection Dosimetry, Vol. 124, No. 1, 1 March, pp. 40-47.

Boursianis, A., Vantias, P., and Samaras, T. (2012), *Measurements for Assessing the Exposure from 3G Femtocells*, Radiation Protection Dosimetry, Vol. 150, No. 2, June, pp. 158-167.

Burgess A. (2004), *Cellular Phones, Public Fears and a Culture of Precaution*, Cambridge: Cambridge University Press.

Calcagnini *et al.*, *Electromagnetic Compatibility of WLAN Adapters with Life-Supporting Medical Devices* (2011), Health Physics, 100 (5): May, 497-501,

Chapman, S., and Schofield, W.N. (1998), *Lifesavers and Samaritans: Emergency Use of Cellular (Mobile) Phones in Australia*, Accident Analysis & Prevention, Vol. 30, No. 6, November, pp. 815-819.

Cooper, T.G., Mann, S.M., Khalid, M., and Blackwell, R.P. (2006), *Public Exposure to Radio Waves near GSM Microcell and Picocell Base Stations*, Journal of Radiological Protection, Vol. 26, No. 2, June, pp. 199-211.

Council Directive 92/58/EEC of 24 June 1992 on the minimum requirements for the provision of safety and/or health signs at work (ninth individual Directive within the meaning of Article 16 (1) of Directive 89/391/EEC).

Directive 2013/35/EU of the European Parliament and of the Council of 26 June 2013 on the minimum health and safety requirements regarding the exposure of workers to the risks arising from physical agents (electromagnetic fields) (20th individual Directive within the meaning of Article 16(1) of Directive 89/391/EEC) and repealing Directive 2004/40/EC.

Dolan, M., and Rowley, J. (2009), *The Precautionary Principle in the Context of Mobile Phone and Base Station Radiofrequency Exposures*, Environmental Health Perspectives, Vol. 117, No. 9, September, pp. 1329-1332.

EMF Explained. Available at <http://www.emfexplained.info/>.

Ericsson: Smart Metering in Australia, 2013. Available at <http://www.ericsson.com/res/thecompany/docs/corporate-responsibility/2012/smart-metering.pdf>.

Ericsson: Mobility Report, June 2014. Available at <http://www.ericsson.com/>.

Eurobarometer 2010 Special Eurobarometer 347: Electromagnetic Fields, Conducted by TNS Opinion & Social at the request of the Directorate General for Health and Consumer Affairs. Survey coordinated by Directorate General Communication.

EVANS PLANNING, MANIDIS ROBERTS, PICONET CONSULTING: Impact of exclusion zone policies on siting base stations: Australian case study analysis, GSMA, August 2012.

GSMA, Mobile Infrastructure Sharing, 2008. Available at <http://www.gsma.com/publicpolicy/public-policy-resources/mobiles-green-manifesto>

GSMA: Mobile's Green Manifesto, 2012.

GSMA and MMF: RF safety at base station sites, 2008, available at <http://www.gsma.com/publicpolicy/gsma-joint-brochure-rf-safety-at-base-station-sites> .

GSMA and MMF: Risk Communication Guide for Mobile Phones and Base Stations, 2009, available at <http://www.gsma.com/publicpolicy/mobile-and-health/risk-communications>.

GSMA, Orange, Universitat Oberta de Catalunya, Case study: University goes portable with tablet technology, (2012).

Health Council of the Netherlands: GSM Base Stations, The Hague, Publication no. 2000/16E, 2000.

Health Council of the Netherlands: Influence of radiofrequency telecommunication signals on children's brains. The Hague: Health Council of the Netherlands, 2011; publication no. 2011/20E.

ICNIRP 1998, Guidelines for Limiting Exposure to Time-Varying Electric, Magnetic, and Electromagnetic Fields (up to 300 GHz)', ICNIRP guidelines, Health Physics, Vol.74, pp. 494-522.

ICNIRP Statement on the 'Guidelines for limiting exposure to time-varying electric, magnetic, and electromagnetic fields (up to 300 GHz)', ICNIRP, Health Physics, 97(3):257-258, September 2009.

IEC 62209-1 ed1.0 (2005), *Human exposure to radio frequency fields from hand-held and body-mounted wireless communication devices - Human models, instrumentation, and procedures - Part 1: Procedure to determine the specific absorption rate (SAR) for hand-held devices used in close proximity to the ear (frequency range of 300 MHz to 3 GHz)*.

IEC 62209-2 ed1.0 (2010), *Human exposure to radio frequency fields from hand-held and body-mounted wireless communication devices - Human models, instrumentation, and procedures - Part 2: Procedure to determine the specific absorption rate (SAR) for wireless communication devices used in close proximity to the human body (frequency range of 30 MHz to 6 GHz)*.

IEC 62232 ed1.0 (2011), *Determination of RF field strength and SAR in the vicinity of radiocommunication base stations for the purpose of evaluating human exposure*.

IEEE C95.2-1999, IEEE Standard for Radio-Frequency Energy and Current-Flow Symbols.

IEEE C95.7-2005, IEEE Recommended Practice for Radio Frequency Safety Programs, 3 kHz to 300 GHz.

ISO/TR 21730:2007, *Health informatics -- Use of mobile wireless communication and computing technology in healthcare facilities -- Recommendations for electromagnetic compatibility (management of unintentional electromagnetic interference) with medical devices*.

ITU Workshop on Short Range Devices and Ultra Wide Band' Geneva, 3 June 2014. Accessed at <http://www.itu.int/en/ITU-R/study-groups/workshops/RWP1B-SRD-UWB-14/Presentations/International,regionalandnationalregulationofSRDs.pdf>.

ITU-D, 2014, Report on Question 23/1, Strategies and Policies Concerning Human Exposure to Electromagnetic Fields. [http://www.itu.int/dms\\_pub/itu-d/opb/stg/D-STG-SG01.23-2014-PDF-E.pdf](http://www.itu.int/dms_pub/itu-d/opb/stg/D-STG-SG01.23-2014-PDF-E.pdf)

ITU-T Supplement 1 to Recommendation ITU-T K.91 (2014), Guide on electromagnetic fields and health.

- Iskra *et al.* (2007), *Potential GPRS 900/180-MHz and WCDMA 1900-MHz Interference to Medical Devices*, IEEE Transactions on Biomedical Engineering, 54(10):1 October, 858-1866.
- Joyner, K.H., Van Wyk, M.J., and Rowley, J.T. (2014), *National Surveys of Radiofrequency Field Strengths from Radio Base Stations in Africa*, Radiation Protection Dosimetry, Vol. 158, No. 3, February, pp. 251-262, accessed at <http://rpd.oxfordjournals.org/content/158/3/251>.
- Mazar, H., *Radio Spectrum Management: Policies, Regulations, Standards and Techniques*, West Sussex: John Wiley & Sons, forthcoming.
- Ministry for the Environment (2009), *National Environmental Standards for Telecommunication Facilities: Users' Guide*, Wellington.
- Mobile Carriers Forum (2001), *Guidelines for Better Visual Outcomes Low-impact Mobile Facilities*.
- Mobile Carriers Forum (August 2007), *Mobile Network Base Station Deployment Technical Paper*.
- Morrissey, *Mobile Phones in the Hospital: Improved Mobile Communication and Mitigation of EMI Concerns Can Lead to an Overall Benefit to Healthcare* (2004), Health Physics, 87(1): July, 82-88.
- NRPB (2004), *Mobile Phones and Health 2004: Report by the Board of NRPB*, Vol. 15, No. 5 available from <http://www.hpa.org.uk/>.
- Recommendation ITU-R BS.1698-0 (2005), *Evaluating fields from terrestrial broadcasting transmitting systems operating in any frequency band for assessing exposure to non-ionizing radiation*. <http://www.itu.int/rec/R-REC-BS.1698/en>
- Recommendation ITU-T K.52 (2004), *Guidance on complying with limits for human exposure to electromagnetic fields*.
- Recommendation ITU-T K.61 (2008), *Guidance on measurement and numerical prediction of electromagnetic fields for compliance with human exposure limits for telecommunication installations*.
- Recommendation ITU-T K.70 (2007), *Mitigation techniques to limit human exposure to EMFs in the vicinity of radiocommunication stations*.
- Recommendation ITU-T K.83 (2011), *Monitoring of electromagnetic field levels*.
- Recommendation ITU-T K.91 (2012), *Guidance for assessment, evaluation and monitoring of human exposure to radio frequency electromagnetic fields*.
- Recommendation ITU-T K.100 (2014), *Measurement of radio frequency electromagnetic fields to determine compliance with human exposure limits when a base station is put into service*.
- Rowley, J.T., and Joyner, K.H. (2012), *Comparative International Analysis of Radiofrequency Exposure Surveys of Mobile Communication Radio Base Stations*, Journal of Exposure Science and Environmental Epidemiology, Vol. 22, No. 3, May/June, pp. 304-315, accessed at <http://www.ncbi.nlm.nih.gov/pmc/articles/PMC3347802/>.
- Swedish Radiation Safety Authority (Strålsäkerhetsmyndigheten, SSM). Eighth report from SSM's Scientific Council on Electromagnetic Fields. March 2013.
- Tang *et al.* (2009), *Electromagnetic Interference Immunity Testing of Medical Equipment to Second- and Third-Generation Mobile Phones*, IEEE Transactions on Electromagnetic Compatibility, 51(3, Part 2): August, 659-664.

- Valberg, P.A., Van Deventer, T.E., and Repacholi, M.H. (2007), *Base Stations and Wireless Networks – Radiofrequency (RF) Exposures and Health Consequences*, Environmental Health Perspectives, Vol. 115, No. 3, March, pp. 416–424.
- Van Der Togt *et al.* (2008), *Electromagnetic Interference From Radio Frequency Identification Inducing Potentially Hazardous Incidents in Critical Care Medical Equipment*, JAMA, 299(24): 25 June, 2884-2890.
- World Health Organization (2002), *Establishing a Dialogue on Risks from Electromagnetic Fields* available at [http://www.who.int/peh-emf/publications/risk\\_hand/en/](http://www.who.int/peh-emf/publications/risk_hand/en/).
- World Health Organization, *Electromagnetic fields and public health: Base stations and wireless technologies*, Backgrounder, May 2006 available at <http://www.who.int/peh-emf/publications/facts/fs304/en/>.
- Wu, O., Briggs, A., Kemp, T., Gray, A., Macintyre, K., Rowley, J., and Willett, K. (2012), *Mobile Phone Use for Contacting Emergency Services in Life-Threatening Circumstances*, The Journal of Emergency Medicine, Vol. 52, No. 3, March, pp. 291-298.e3.
- Zarikoff, B., Malone, D. (2013), *A Comparison of RF Exposure in Macro- and Femtocells*, Health Physics, Vol. 105, No. 1, July, pp. 39-48.

## Annex 1

### Smart sustainable city - EMF check-list

The 'Smart Sustainable City EMF Check-list' is designed to provide an easy to use reference for city officials and planners in order to ensure that smart city ICT designs using wireless systems operate efficiently and in compliance with EMF exposure standards.

The following check-list<sup>19</sup> identifies the key elements for EMF compliance and wireless network deployment efficiency.

No.	Smart sustainable city - EMF check-list	Check
1	<b>EMF compliance framework</b> Ensure that an EMF compliance framework is established to protect the general public and workers from the adverse effects of EMF.	<input type="checkbox"/>
2	<b>ICT devices meet ICNIRP RF-EMF exposure guidelines</b> Ensure that devices are assessed for compliance with the public exposure guidelines.	<input type="checkbox"/>
3	<b>Wireless networks meet ICNIRP RF-EMF exposure guidelines</b> Ensure that the network sites are assessed for compliance to the ICNIRP guidelines, and that access controls and safety procedures are in place for working at antenna sites.	<input type="checkbox"/>
4	<b>Document RF-EMF compliance</b> Ensure that the EMF compliance for ICT devices and networks is documented.	<input type="checkbox"/>
5	<b>Base station antennas are selected to suit the ICT network requirements</b> Ensure that the appropriate base station antennas are used to improve ICT efficiency, provide services and integrate with the environment.	<input type="checkbox"/>
6	<b>Wireless network antennas are located in close proximity to the ICT devices</b> Ensure that network and base station antennas are located where the ICT devices are being used.	<input type="checkbox"/>
7	<b>Planning legislation incorporates ICT networks and antenna requirements</b> Ensure more efficient deployment of ICT systems through a consistent approach to planning approval.	<input type="checkbox"/>
8	<b>EMF ICT compliance information is available</b> Ensure that EMF compliance information is available to the public and other interested stakeholders.	<input type="checkbox"/>
9	<b>General EMF information is available to the community</b> Ensure that the references for EMF information are the WHO and ITU resources.	<input type="checkbox"/>
10	<b>Existence of wireless network information programme</b> Ensure availability of information about the operation of wireless networks based on credible sources and using appropriate communication channels addressing compliance, health concerns and siting.	<input type="checkbox"/>

<sup>19</sup> This check-list does not replace national regulatory or other legal requirements.



## Annex 2

### Summary of ICNIRP guidelines

In 1998, the International Commission on Non-Ionizing Radiation Protection (ICNIRP)<sup>20</sup> published their guidelines on limiting exposure to EMF, to protect against all known adverse health effects. This publication resulted from a thorough review of the scientific literature and assessed all health risks to both the general public and workers. The exposure limits have incorporated large safety factors to allow for uncertainties in the sensitivities of people to EMF and in the scientific studies.

#### Basic restrictions

In the frequency range from 10 MHz to 10 GHz, that includes the frequencies used for mobile and wireless communications, the RF exposure limits (basic restrictions) are expressed as SAR values, see Table 4. The specific absorption rate (SAR) is the rate at which RF energy is absorbed in body tissues and is expressed in units of W/kg.

**Table 4 – ICNIRP basic restrictions applicable to wireless services 10 MHz to 10 GHz**

Type of exposure	Frequency	Whole body average SAR (W/kg)	Localised SAR (head and trunk) (W/kg)	Localised SAR (limbs) (W/kg)
Occupational worker	10 MHz -10 GHz	0.4	10	20
General public	10 MHz -10 GHz	0.08	2	4

For frequencies from 10 GHz to 300 GHz, the ICNIRP basic restrictions are given in terms of power density, see Table 5.

**Table 5 – ICNIRP basic restrictions applicable to wireless services between 10 GHz and 300 GHz**

Type of exposure	Equivalent plane wave power density (W/m <sup>2</sup> )
Occupational exposure	50
General public	10

#### Reference levels

The 'basic restrictions' are the actual limits based on the mechanism by which the RF fields affect tissues. For practical assessments, ICNIRP also provides the equivalent frequency dependent "reference levels", expressed as electric field (V/m), magnetic field (A/m) and power density (W/m<sup>2</sup>), so that RF measurement equipment can be used to determine compliance, see Table 6. While the

<sup>20</sup> <http://www.icnirp.org/cms/upload/publications/ICNIRPemfgdl.pdf>

reference levels can be used to show compliance with SAR limits, exceeding the reference levels does not necessarily mean the SAR limit has been exceeded. In this case, further tests would need to be conducted to determine whether the basic restriction (SAR) has been exceeded.

**Table 6 – ICNIRP basic restrictions applicable to wireless services above 10 MHz**

Type of exposure	Frequency	E-field strength (V/m)	H-field strength (A/m)	Equivalent plane wave power density Seq (W/m <sup>2</sup> )
Occupational/worker	10-400 MHz	61	0.16	-
	400-2000 MHz	$3f^{1/2}$	$0.008f^{1/2}$	$f/40$
	2-300 GHz	137	0.36	50
General public	10-400 MHz	28	0.073	-
	400-2000 MHz	$1.375f^{1/2}$	$0.0037f^{1/2}$	$f/200$
	2-300 GHz	61	0.16	10

NOTE – Where f is as indicated in the frequency column.

WHO has promoted the adoption of ICNIRP guidelines by national authorities because ICNIRP is a formally recognized non-governmental organization of WHO that works closely with WHO on all areas of non-ionizing radiation protection. In addition, ICNIRP uses the WHO's health risk assessments for developing their guidelines. ITU also encourages Member States to adopt the ICNIRP guidelines.

Exposure limits for RF workers are higher than for the general public because workers are adults who are normally exposed under controlled conditions, are trained to be aware of any potential risks and to take the appropriate precautions. The public comprises people with widely different ages, from babies to the elderly, who should not be expected to take any precautions to avoid RF exposures. Thus the public exposure limits incorporate very large safety factors; they are 50 times below the RF exposure level at which the first health effects are seen. By contrast, the occupational exposure limits are 10 times lower.

## Annex 3

### Summary of typical exposure levels

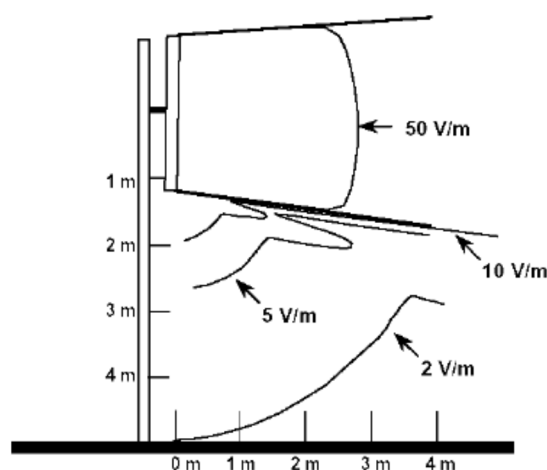
Typical exposures from mobile communication systems and other similar uses of radio signals are summarized in Table 7 based on the results of a WHO workshop (Valberg *et al.*, 2007).

**Table 7 – Typical maximum exposures for a range of wireless services**

Service	ICNIRP reference level	Typical maximum exposure
Average urban, base stations	41 to 61 V/m	0.1–0.3 V/m
Average urban, TV and radio	28 V/m	0.4–0.7 V/m
Wi-Fi access point (20 cm)	61 V/m	3.9 V/m
DECT cordless phone (20 cm)	58 to 61 V/m	11.5 V/m
Baby monitors (20 cm)	28 to 61 V/m	8.5 V/m

Wireless technologies are based on international regulations and technical standards. There is little variation in the level of exposure between countries as shown in analyses of base station measurement surveys conducted internationally (Rowley *et al.*, 2012) and in developing regions such as Africa (Joyner *et al.*, 2014). The global average reported from 173,000 measurement points from 23 countries conducted from the year 2000 onwards was  $0.073 \mu\text{W}/\text{cm}^2$  ( $730 \mu\text{W}/\text{m}^2$ ), approximately 5,500 times (in power-density and 74 in field-strength) below the most restrictive ICNIRP reference level for the public relevant to these mobile communication services of  $400 \mu\text{W}/\text{cm}^2$  ( $4\text{W}/\text{m}^2$ ) at 800 MHz.

The ICNIRP reference levels are only likely to be approached in areas close to the transmitting antennas as shown in Figure 23.



Source: From Figure 5, p. 20, of the Health Council of the Netherlands, 2000.

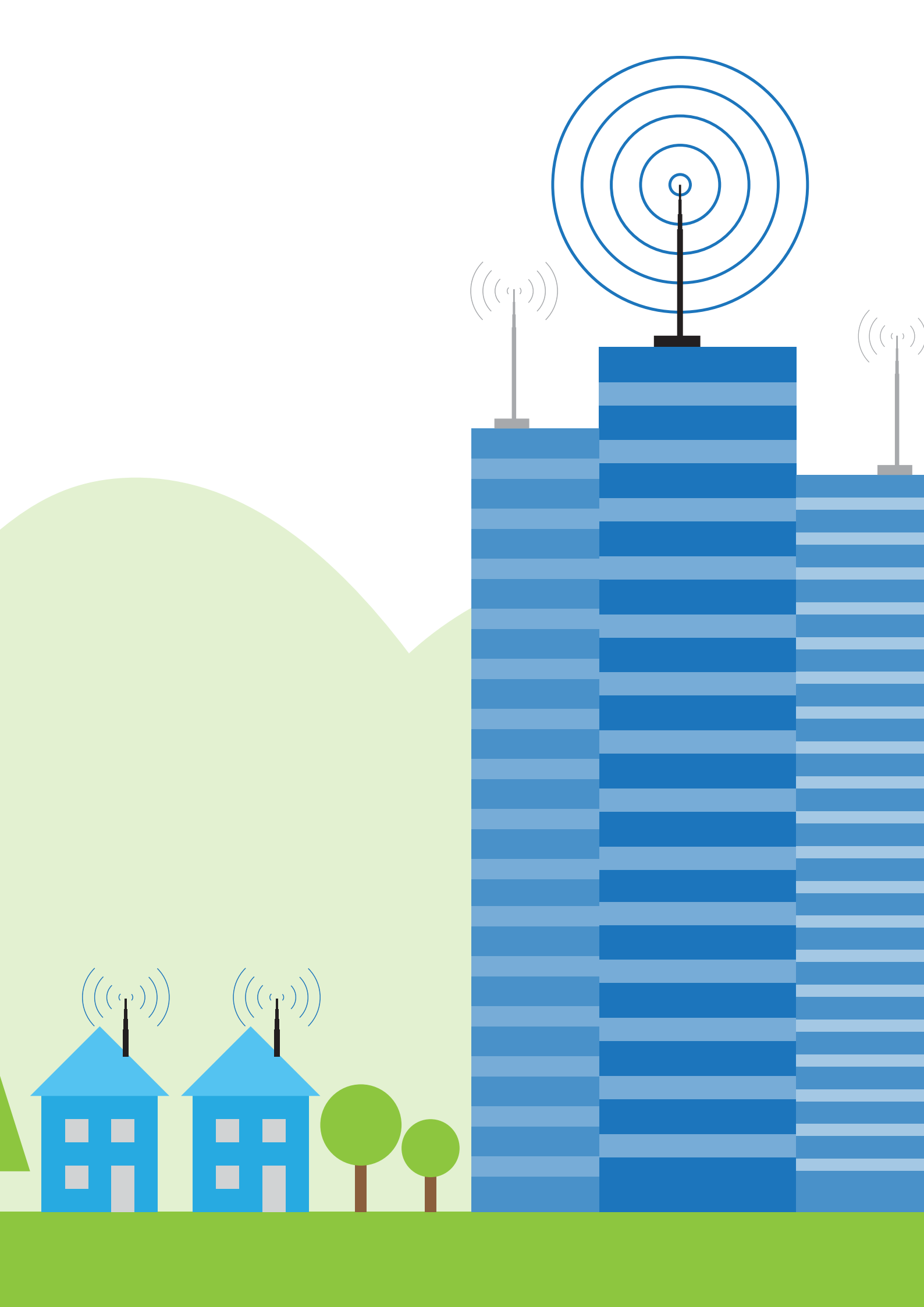
**Figure 23 – Exposure levels near a GSM base station antenna with a radiating power of 20 W transmitting at 900 MHz**

## Annex 4

### Abbreviations and acronyms

3D	Three Dimensional
3G	3rd Generation mobile technology
4G	4th Generation mobile technology
AM	Amplitude Modulation
AMR	Automatic Meter Reading
CENELEC	European Committee for Electrotechnical Standardization
DAS	Distributed Antenna Systems
DECT	Digital Enhanced Cordless Telecommunication
DVB-T	Digital Video Broadcasting - Terrestrial
DSL	Digital Subscriber Line
EIRP	Equivalent Isotropic Radiated Power
EMC	ElectroMagnetic Compatibility
EMF	ElectroMagnetic Field
EMR	ElectroMagnetic Radiation
ERP	Effective Radiated Power
FCC	Federal Communications Commission
FM	Frequency Modulation
Gbit/s	Giga bits per second
GHG	Greenhouse Gas
GPS	Global Positioning System
GSMA	Global System for Mobile Communications Association
GSM	Global System for Mobile communications
HF	High Frequency
HVAC	Heating, Ventilation, and Air Conditioning
IAC	International Advisory Committee
IARC	International Agency for Research on Cancer
IBC	In-Building Coverage
ICNIRP	International Commission on Non-Ionizing Radiation Protection
ICT	Information and Communication Technology
IEC	International Electrotechnical Commission
ISM	Industrial, Scientific, and Medical

ITC	Intelligent Traffic Control
ITU	International Telecommunication Union
LAN	Local Area Network
LTE	Long-Term Evolution
M2M	Machine-to-Machine
Mbit/s	Megabits per second
NCD	Non-Communicable Diseases
RAN	Radio Access Network
RF	Radio Frequency
RF-ID	Radio Frequency Identification
SAR	Specific Absorption Rate
SMS	Short Message Service
SRD	Short Range Devices
TTT	Transport and Traffic Telematics
TV	Television
UHF	Ultra High Frequency
VHF	Very High Frequency
WAN	Wide Area Network
WHO	World Health Organization
WiMAX	Worldwide Interoperability for Microwave Access
Wi-Fi	Wireless Fidelity
WLAN	Wireless Local Area Network
Xds	x-type Digital Subscriber Line







**Transport**



**Health**



**Home**

Integrated  
Management

Everything  
will be  
connected.



**Building**



**Cities**

# 3.9

**Integrated  
management for smart  
sustainable cities**

## Acknowledgements

This Technical Report was researched and written by Nengcheng Chen (Wuhan University, China), Ziqin Sang (Fiberhome Technologies Group, China), Wenyong Du (Wuhan University, China) and Zeqiang Chen (Wuhan University, China). The authors also acknowledge the guidance and support from all the members of the FG-SSC Management Team, and especially Flavio Cucchiatti (Telecom Italia, Italy, and FG-SSC Vice-Chairman) and Paolo Gemma (Huawei, China, and FG-SSC Working Group 2 Coordinator).

Additional information and material relating to this Technical Report can be found at: [www.itu.int/itu-t/climatechange](http://www.itu.int/itu-t/climatechange). If you would like to provide any additional information, please contact Cristina Buetti at [tsbsg5@itu.int](mailto:tsbsg5@itu.int).

## Table of contents

		Page
<b>1</b>	<b>Introduction .....</b>	<b>654</b>
	1.1 Background .....	654
	1.2 Service framework .....	655
	1.3 Intended application .....	656
<b>2</b>	<b>Resources, challenges and technologies of IMSSC .....</b>	<b>657</b>
	2.1 Resources of IMSSC.....	657
	2.2 Challenges of IMSSC.....	659
	2.3 Technologies of IMSSC.....	661
<b>3</b>	<b>Integrated management for smart sustainable cities.....</b>	<b>664</b>
	3.1 Overview .....	664
	3.2 Meta-models for resource integrating.....	666
	3.3 Technical specifications for fusion process.....	669
	3.4 Interface specifications for management service.....	671
<b>4</b>	<b>Instances of the integrated management for smart sustainable cities .....</b>	<b>674</b>
	4.1 Daily management .....	674
	4.2 Emergency response management .....	674
<b>5</b>	<b>Conclusions .....</b>	<b>675</b>
	<b>Bibliography .....</b>	<b>677</b>
	<b>Annex – Abbreviation and acronyms.....</b>	<b>680</b>



17-42	2015.04.11	+150.27 \$
10.11	2015.04.10	-50.27 \$
09.25	2015.04.10	+801.20 \$
15.20	2015.04.10	+100.21 \$
15.20	2015.04.09	-328.63 \$
12.41	2015.04.09	-199.99 \$
11.07	2015.04.09	-251.85 \$
08.52	2015.04.09	-9.68 \$
18.12	2015.04.09	-1.24 \$
		1.8 \$
		8 \$
		1.8 \$

- Ann
- Bryan
- Thomas
- Tony

- Task 1
- Task 2
- Task 3

## Integrated management for smart sustainable cities

### Executive summary

This Technical Report has been developed within the Focus Group on Smart Sustainable Cities (FG-SSC) and provides a technical proposal for integrated management, which can be followed by any municipality interested in improving the management of its infrastructure, operations and citizen interactions, and in addressing critical urban challenges – such as security, criminality, pollution, traffic congestion, inadequate infrastructure, and response to natural hazards. Information and communication technologies (ICTs) proved to be instrumental to support urbanization and allow the transition towards smart sustainable cities. The rapid proliferation of ICT products and solutions in cities has led to the lack of uniformity in tools, such as information representation methods, software interface specifications, etc., posing additional challenges to urban management practices.

Integrated management for smart sustainable cities (IMSSC) seeks to alleviate challenges in the smart sustainable cities management through the incorporation of sensor web, model web, service interfaces, ICT products, Internet of things (IoT) as well as the cloud computing technologies in areas of city operations and management. Integration of such technologies is adapted to continuously resolve the problems in smart sustainable cities management by encoding, fusing and sharing the information resources of the cities in a unified way.

Recognizing the impact that IMSSC can have on the city management, the International Telecommunication Union (ITU) established the Focus Group on Smart Sustainable Cities (FG-SSC) with the vision that cities worldwide can be empowered to alleviate and overcome management challenges effectively and become smarter and more sustainable.

By promoting the coordinated development and management of smart sustainable cities, IMSSC allows cities to maximize socio-economic institutions as well as keep the city operate in an orderly way. However, in order to realize the orderly operation of all relevant sectors in the cities, a series of technical specifications are essential. Thus this Technical Report aims at emphasizing the management problems faced by cities and at providing IMSSC as a possible solution to mitigate such challenges, with the goal of generating further dialogue and discussion.



# 1 Introduction

## 1.1 Background

"A smart sustainable city is an innovative city that uses information and communication technologies (ICTs) and other means to improve quality of life, efficiency of urban operation and services, and competitiveness, while ensuring that it meets the needs of present and future generations with respect to economic, social, environmental as well as cultural aspects".

The above definition describes what a smart sustainable city should be. However, significant urban challenges – such as security, criminality, pollution, traffic congestion, inadequate infrastructure, response to natural hazards – still prevent this vision to become reality. Some examples of the challenges faced by cities are listed in Figure 1.



**Figure 1 – Examples of challenges faced by cities**

In order to successfully address these challenges, cities should take into consideration the deployment of the necessary tools to be able to monitor, map and report what is happening in real time. An effective reporting mechanism will ensure that such problems are tackled rapidly to avoid or reduce possible casualties and economic losses [b-Namb]. As part of a recent widespread urban digitalization process, several cities have deployed a variety of sensors, including cameras, rain gauge, and pressure transducer, etc., to be able to acquire first-hand information about all city's operations in a timely manner. Even if all this information is available in cities, it is unfortunately distributed in different departments or even regions. Nonetheless, an effective management mechanism is still lacking.

In response to this challenge, this Technical Report proposes an integrated management solution for smart sustainable cities. With IMSSC, the sensors, nodes, and models can function in an organized way. As a result, when emergency events occur, the data, models and other resources needed can be rapidly discovered and acquired. To achieve the goal of making a city smarter and more sustainable, the first step is to analyse real-time processes and understand event patterns

through event modeling. Additional capabilities, in terms of processing units, application units, as well as models, might be needed. Secondly, there is a need for fusion processing guidance, so that different sources of observations can be combined together to compensate their own deficiencies and attain the goal more efficiently. Finally, services for information resource publishing and sharing as well as result fusing are also necessary to disseminate information across the concerned agencies. By adopting the integrated management system, each city can make a big step towards the implementation of the smart sustainable cities vision.

### 1.2 Service framework

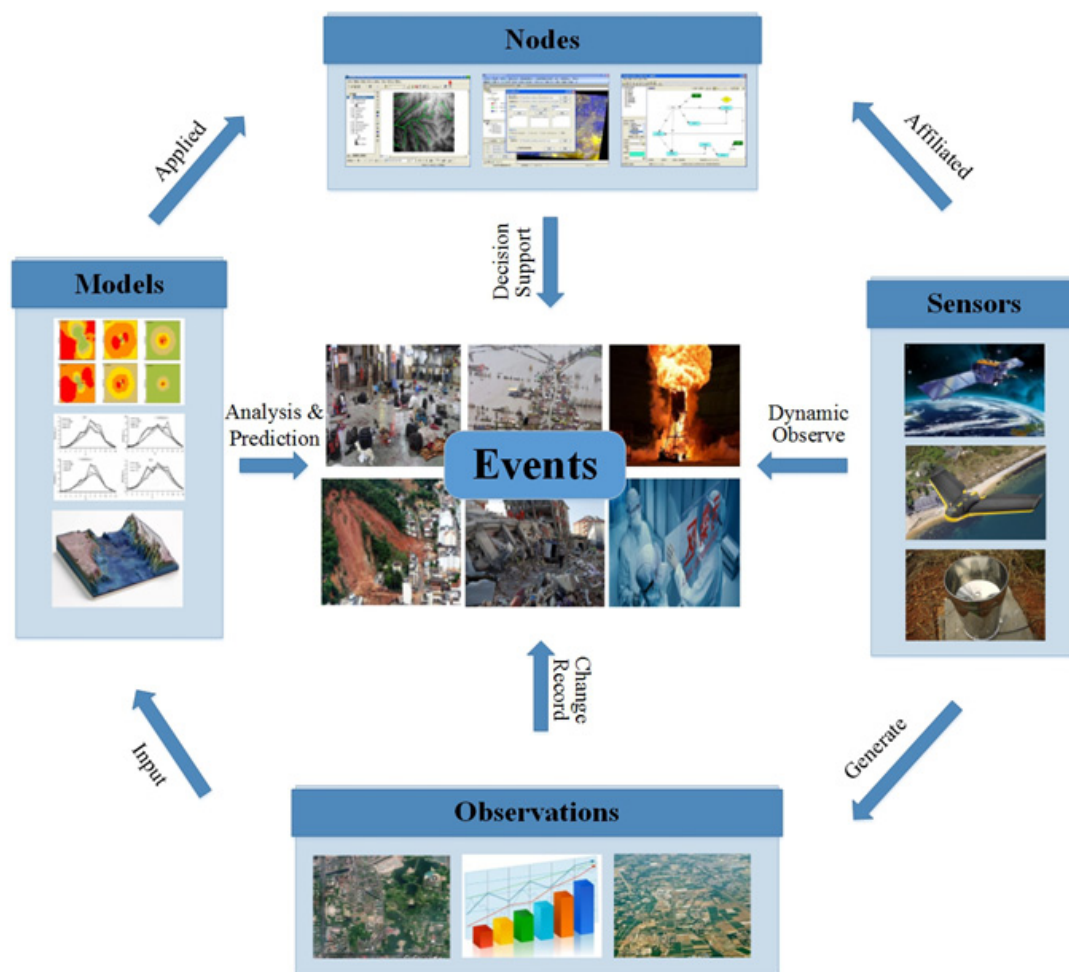
The users involved in IMSSC are not only municipal departments, but also enterprises and citizens. Municipalities are usually in charge of the daily operation and maintenance of IMSSC which is initiated by them. When emergency events occur, they need to synthesize all the information and make proper decisions to rescue lives and reduce economic losses. Citizens are the users and main beneficiaries of the integrated management for smart sustainable cities. They are able to report problems of daily management, emergencies, as well as receive notifications from the municipal authorities. Enterprises can be viewed from two perspectives: some enterprises can take part and assist the municipality to improve the capacities of the integrated management, others can just act as ordinary citizens to do the work of reporting or notice feedback. The service framework of IMSSC is represented in Figure 2.



Figure 2 – Service framework of IMSSC

### 1.3 Intended application

The proposed integrated management solution of smart sustainable cities aims at tackling four main types of problems, namely inadequate safety and security protection, increasingly worsened urban environment, damaged city infrastructure, and natural or man-made emergency events. In this Technical Report, these four types of problems are represented as theoretical events through a uniform event information model. They are detected by sensors, recorded by observations, analysed and processed by models, and finally settled by a decision made according to nodes. The goal of IMSSC is achieved by the direct management of information resource carriers, events, sensors, observations, models, and nodes. The roles of the different information resources in IMSSC are presented in Figure 3:



**Figure 3 – Roles of the different information resources in IMSSC**

These information resources represent the crucial infrastructure for real-time monitoring of city dynamic processes. However, these resources have not yet been efficiently used due to the lack of a unified management of the observation resources and information carriers, the rapid and smooth processing of information, as well as the real-time publishing and sharing services. As a consequence, the interconnection among the different city departments has not been established yet. This is a missed opportunity for every city administration as events like traffic congestion, urban flooding, and pipeline leakage that existed before perpetuate. The operational efficiency of cities is not always as satisfying as it could be, affecting negatively citizens' quality of life. Therefore, it is imperative to perform IMSSC to resolve all the challenges described above.

IMSSC is to model the information resources of cities uniformly, fuse the data from the information resources to acquire a higher level of information, and share the information to serve people in cities [b-Nama]. In this Technical Report, information resources are composed of nodes, sensors, data, models, and events, among which nodes include sensing nodes, processing nodes, and application nodes, and sensors are affiliated to sensing nodes. The fusion process aims to fuse the information resources with toponym and maps, respectively. Services mainly include data, model and event service. IMSSC is able to ensure the well-organized and efficient operation of people, things and streams in cities, so that disastrous events can be detected in advance and timely avoided before the occurrence, so that casualties and economic losses can be reduced as much as possible. At the same time, IMSSC is able to settle the widely-existing problems, such as traffic congestion, and environmental pollution, etc., improve the living quality of citizens, protect the environment, and implement the sustainable development of cities.

The objectives and challenges of IMSSC, as well as the technologies used to address the problems and to achieve the goals of smart sustainable cities development are illustrated in section 2. The specific meta-models, fusion processing workflows, and services proposed for IMSSC are presented in section 3, while section 4 provides examples pertaining to the application of meta-models, fusion processing workflows, and services for IMSSC. Section 5 is a summary of this Technical Report.

## 2 Resources, challenges and technologies of IMSSC

---

### 2.1 Resources of IMSSC

IMSSC aims at offering a solution to all problems affecting current urban development, including inadequate safety and security protection, increasingly worsened urban environment, damaged city infrastructure, and natural or man-made emergency events, in a rapid and efficient way. IMSSC is also expected to improve citizen's quality of life, efficiency of urban operation and services, and competitiveness, while ensuring at the same time that the needs of present and future generations with respect to economic, social and environmental aspects are met.

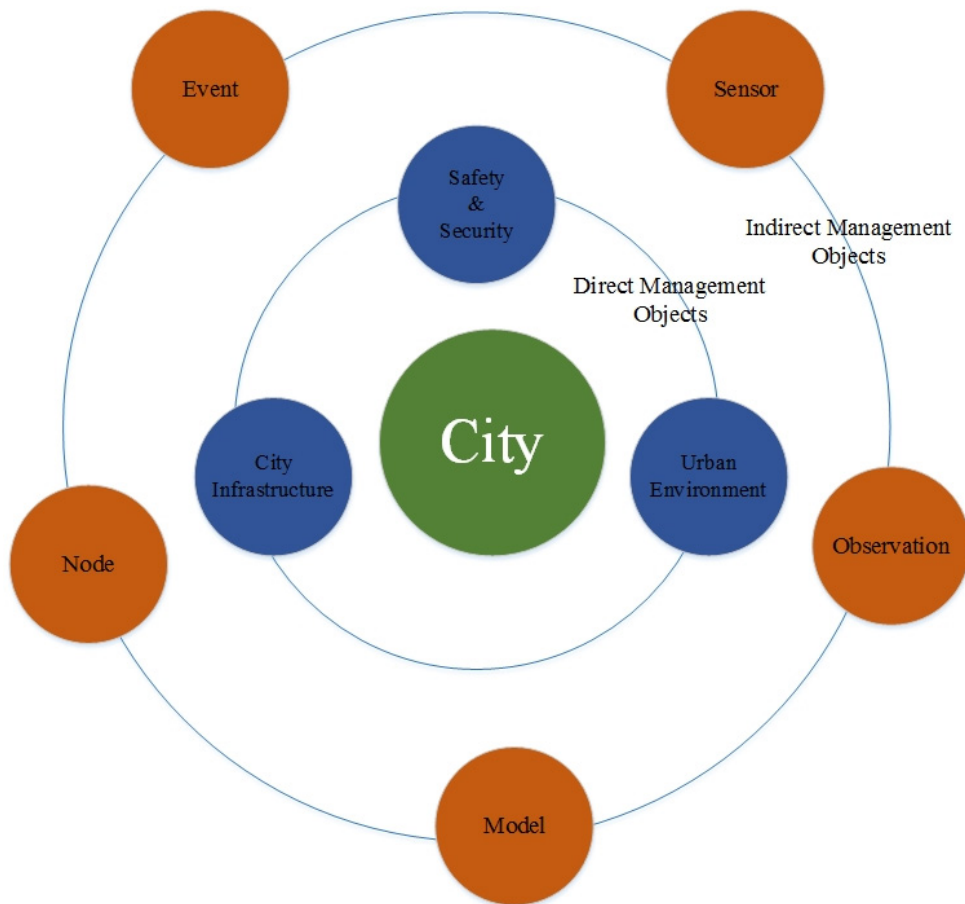
These problems are the results of the interaction among people, urban infrastructure, and the corresponding environment in cities. Citizens are the main players of a city. Their activities determine and influence the existence and evolution of the urban infrastructure and environment. There is a saying that "people who live in cities create the urban landscape." It is human beings that constitute the versatility of a city, create a beautiful life and live it. Consequently, citizens are the direct object of IMSSC.

Urban infrastructure is a general term for all types of urban facilities on which various economic activities and other social activities occur for the survival and development of cities, and it is divided into the engineering infrastructure and social infrastructure. It is particularly important for production units, and is one of the necessary conditions to reach its economic, environmental and social benefits. Engineering infrastructure generally refers to energy systems, water supply and drainage systems, transportation systems, communication systems, environmental systems, disaster prevention systems and other engineering facilities. Social infrastructure refers to the administration, education, health care, business services, finance and insurance, social welfare and other facilities. The urban infrastructure provides citizens with what they need for their daily life. A good urban infrastructure enables improved quality of life and significant steps toward smart sustainable cities development. Therefore, urban infrastructure is also a direct object of IMSSC.

Urban environment here mainly refers to natural conditions of the city, including geology, geomorphology, hydrology, climate, flora and fauna, soil and other various factors. Irrational and excessive expansion of the city's development will lead to the deterioration of the environment. Urban environmental quality directly affects the operation of a city and the living conditions of urban inhabitants. To improve inhabitant dwelling, realize IMSSC, and achieve the harmonious development between human beings and nature, the environment must be the direct object of IMSSC.

The observing, reporting, analysing, forecasting and decision supporting of all these three direct objects are implemented by digital equipment and the associated information systems. In this Technical Report, the challenges listed in Figure 1 as well as the direct objects are abstracted for the convenience of information representing. The challenges are abstracted events and represented by event information models. The digital equipment is abstracted as four kinds of information resources, comprising of sensors, observations, models, and nodes. Among the information resources, sensors are composed of airborne, space borne, and ground-based sensor systems, such as satellite sensors, unmanned aerial vehicles (UAVs), vehicle-mounted mobile measurement systems, global positioning systems (GPSs), radio frequency identification (RFID), temperature and humidity monitors, rainfall sensors and other equipment. This equipment is deployed wherever events may occur and is applied in event monitoring. Observations refer to the data generated by sensors, ranging from numerical values to all kinds of images, and they carry the information which can reflect the event occurrence. There are several kinds of analysing, processing, and forecasting models, such as hydrological analysis models, transportation congestion processing models, and pollutant diffusion models, etc. All these models are useful in analysing, processing observations, or making predictions based on historical and present observations in cases when observations are obscure and cannot provide the intuitive situation changes. Nodes can be united sensing centers, integrated processing units or small size application divisions, and they are able to offer significant decision support for events. Therefore, information resources, including events, sensors, observations, models, as well as nodes are viewed as the indirect objects of IMSSC in this Technical Report. The direct and indirect objects of IMSSC are presented in Figure 4.





**Figure 4 – Direct and indirect objects of IMSSC**

## 2.2 Challenges of IMSSC

In cities nowadays, information resources, like sensors, observations and models, are featured as different sources, great varieties, and huge numbers. However, when responding to the emergency events, many problems still exist, including:

- (1) the encoding formats of the information resources are various, difficult to be integrated;
- (2) the fusion workflow between information resources is not unified, resulting in the non-uniform fusion results, inconsistent accuracy, and difficulty in fusion processing;
- (3) the inconformity of the information resources and their fusion results service interfaces cause trouble in their publishing, sharing, discovering, and accessing [b-Toppeta].

All problems described above pose significant challenges to urban development and to IMSSC.

To be specific, the challenges faced by IMSSC can be illustrated from three perspectives:

- 1) Information resources come from various sources and heterogeneous systems. It is difficult to interconnect such systems for data sharing. Consequently, this leads to difficulties in multi-level collaborative decision-making. Taking sensors as examples, there are space borne platforms (hundreds of orbiting satellites), airborne platforms (thousands of UAVs, airships and balloons, etc.) and ground platforms (millions of ground sensors). However, there is no unified meta-model to represent and manage the huge amounts of



heterogeneous sensors. Information resources with large numbers, different kinds and multiple representation ways are major obstacles in the development and integrated management for smart sustainable cities. The difficulty of information resource management in smart sustainable cities is demonstrated in Figure 5.



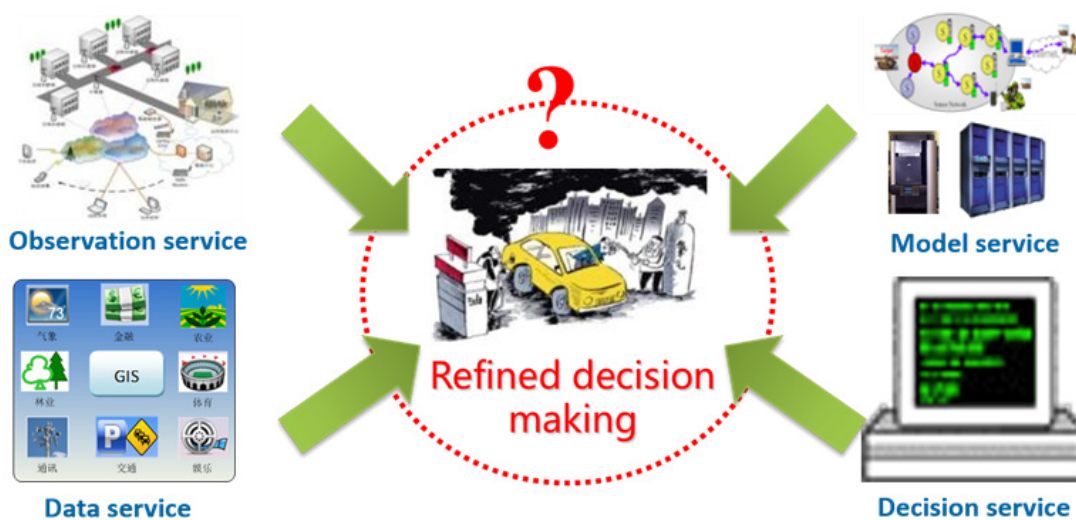
**Figure 5 – Difficulty of information resource management in smart sustainable cities**

- 2) Cooperation between the different information resources is lacking, and their fusion processing is difficult, leading to incomplete and inaccurate decisions. Just in terms of the observation data, only less than 10% of the present observation data can be processed timely and efficiently, and the capability of fusion processing on the space, aerial and ground observation data is insufficient. On one hand, when coping with significant environment and disaster events, the poor timeliness and great time lag of data fusion, processing and collaborative analysis always hinders the first-hand data and information from being delivered to the right place on time. On the other hand, the historical surveying and mapping information database cannot be effectively associated and fused with the current observations, forming the obstacles of information overlay and intuitional display. Thus, the status of events and the situation of the schedulable sources cannot be made clear, leading to incomprehensive and inaccurate decisions. The problem of information fusion processing in smart sustainable cities is elaborated in Figure 6.



**Figure 6 – Problem of information fusion processing in smart sustainable cities**

- 3) The demand granularity of the information resources and fusion results are quite different, together with the distributed resources, inconsistent interfaces, and passive decision services. The information resource interfaces are different, as well as the different user requirements, and distributed service resources. When facing up with great environmental and disaster events, many problems appear, including which data are needed, which sensors can supply the data, which models are in need, and where the models can be found. The non-uniform service interfaces at present are not able to satisfy the complex task requirements, and the active service-focused mode is also absent, resulting in problems of passive and untimely decisions. The problem of refined decision-making in smart sustainable cities is shown in Figure 7.



**Figure 7 – The problem of refined decision-making in smart sustainable cities**

Briefly, the scale of information resources in cities is increasing dramatically, together with the multiple demands from the environment and disaster monitoring. There is an urgent need for establishing an integrated information management infrastructure to implement resource integration, fusion processing, and management service for smart sustainable cities. Through the infrastructure, the heterogeneous observation resources can be combined via the Internet, to form the dynamic coupling mechanisms for collaborative observations, maximize the use of observation resources, provide the task-driven service mode based on the space and time information, and greatly improve the integrated management and service level. During the process, the sustainable monitoring of the environmental safety, the quick response during serious disaster events, and the transformation from the anytime, anybody, anywhere, anything (4A) service to the flexible right time, right body, right place, right thing (4R) service can be completed.

### 2.3 Technologies of IMSSC

Compared with the digital city management, from the technical level, the integrated management for smart sustainable cities is to realize the transformation from the online management based on the Internet to the real-time dynamic management on the basis of IoT, from the sensing management of every single sensor to the collaborative management of multiple sensors, from the island of the industrial model management to the model web management of the application decisions [b-Balazinska].

To be specific, IMSSC consists of the observation web, service web, and model web technologies.

The observation web technology [b-Simonis] aims at breaking through the barriers of the multiple and heterogeneous observing and sensing modes, and at implementing the automatic, real-time, and comprehensive sensing about the city management and operating status via the web, sensing, and intellectual technologies. The architecture of the observation web technology used in smart sustainable cities is presented in Figure 8.

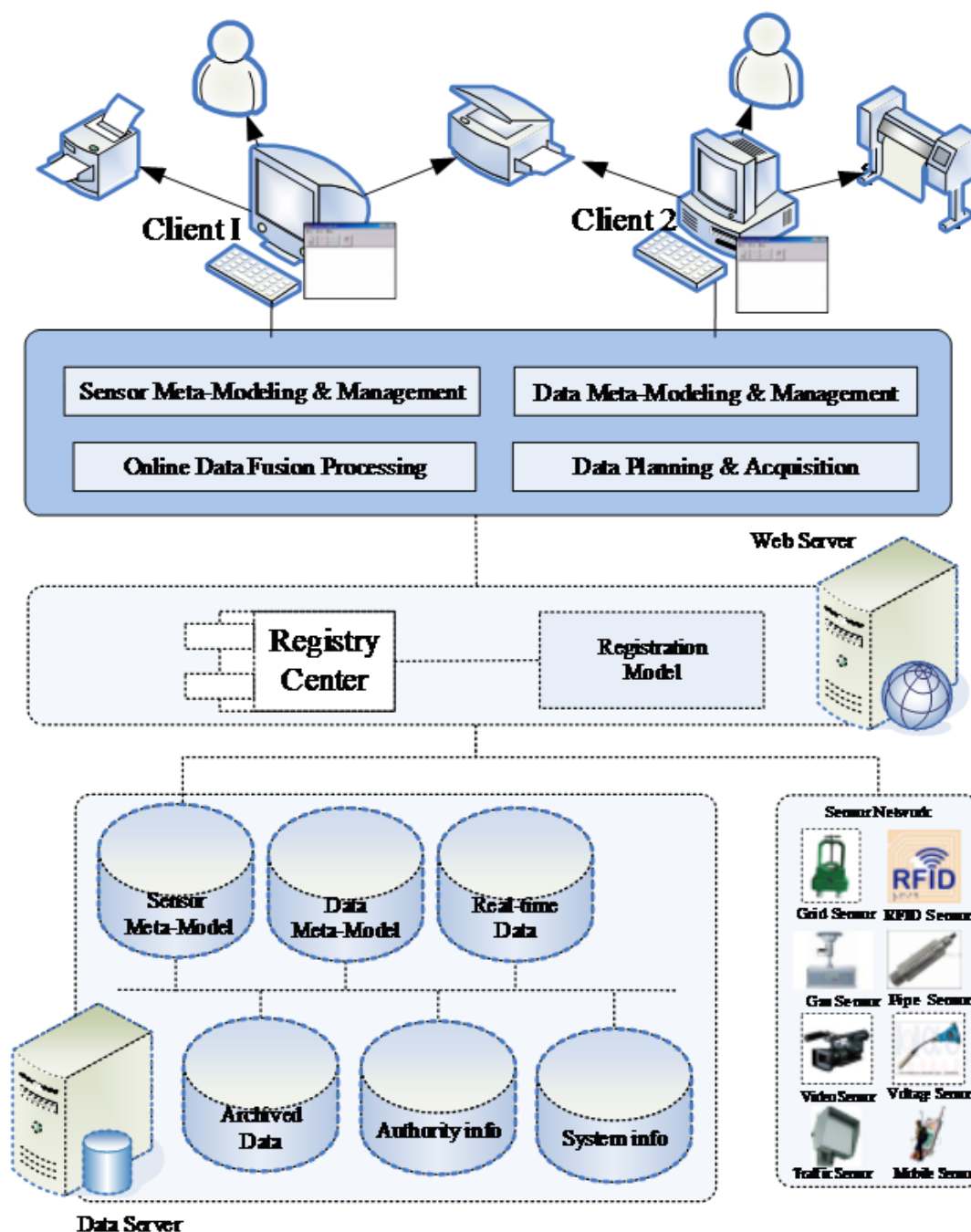
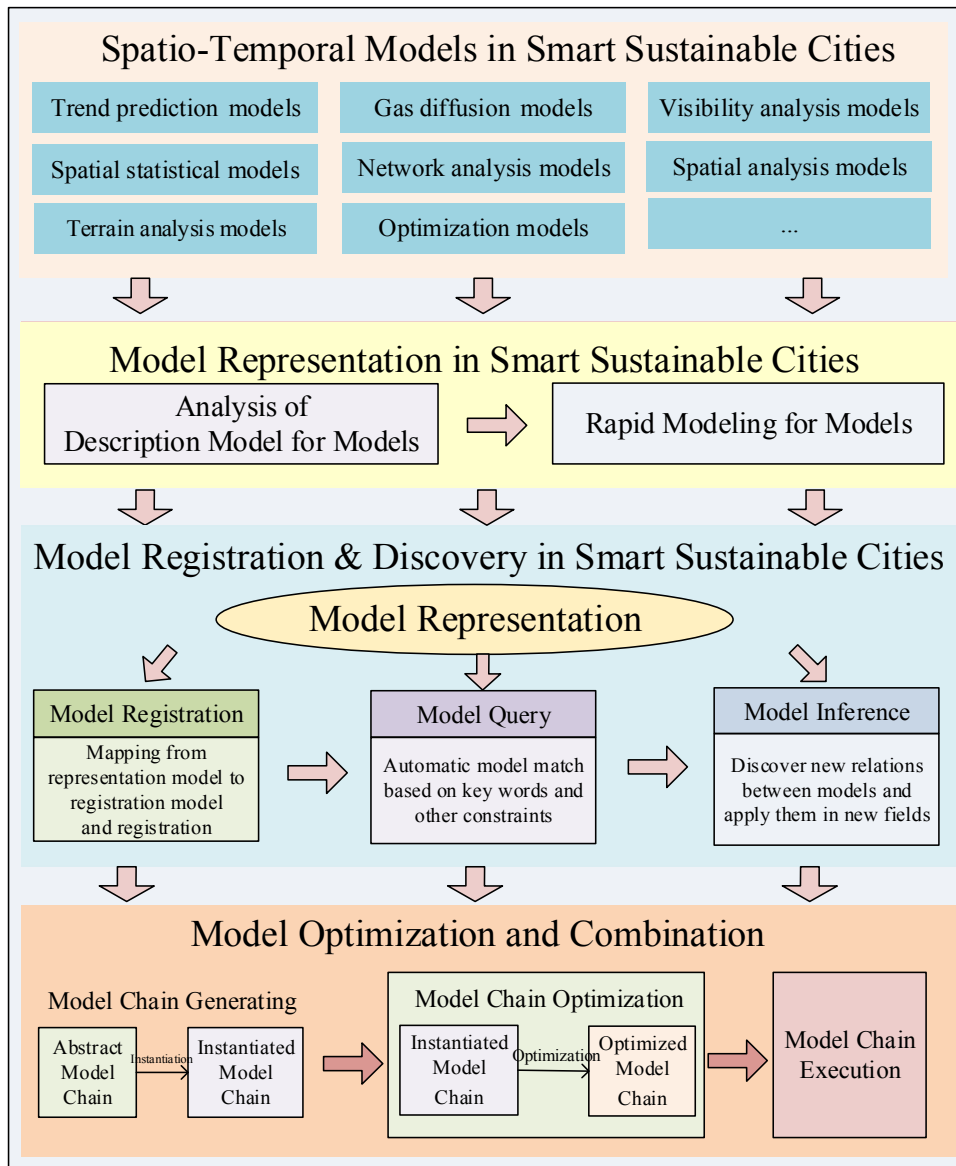


Figure 8 – Architecture of the observation web technology used in smart sustainable cities

The model web technology [b-Nativi] is to hurdle the bars in the meta-modeling as well as catalog registration technology, and to bridge the communication gaps between the heterogeneous sensors, models, as well as simulation and decision support systems. The model web technology could be used to solve the problems in the expression, understanding, sharing and cooperation of the heterogeneous city decision models. Users could realize the city integrated emergency decision by combining and optimizing these models on decision terminals. The framework of the model web technology used in smart sustainable cities is presented in Figure 9.



**Figure 9 – Framework of the model web technology used in smart sustainable cities**

The service web technology [b-ESTO] is to overcome the obstacles in the workflow and sensor web technologies, and to achieve the goal of network intelligent service which is in accordance with specific sensor actions and interface specifications. The framework of the model web technology used in smart sustainable cities is demonstrated in Figure 10.



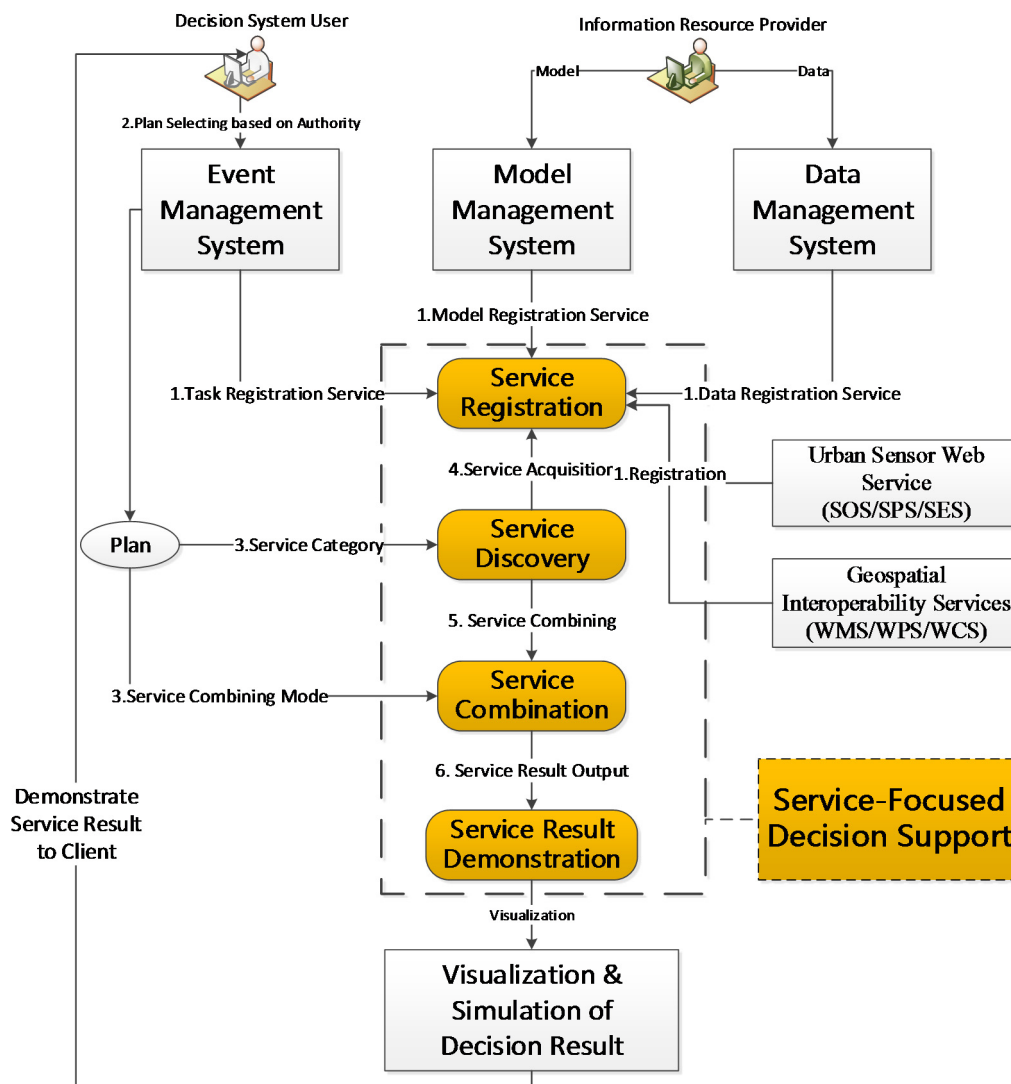
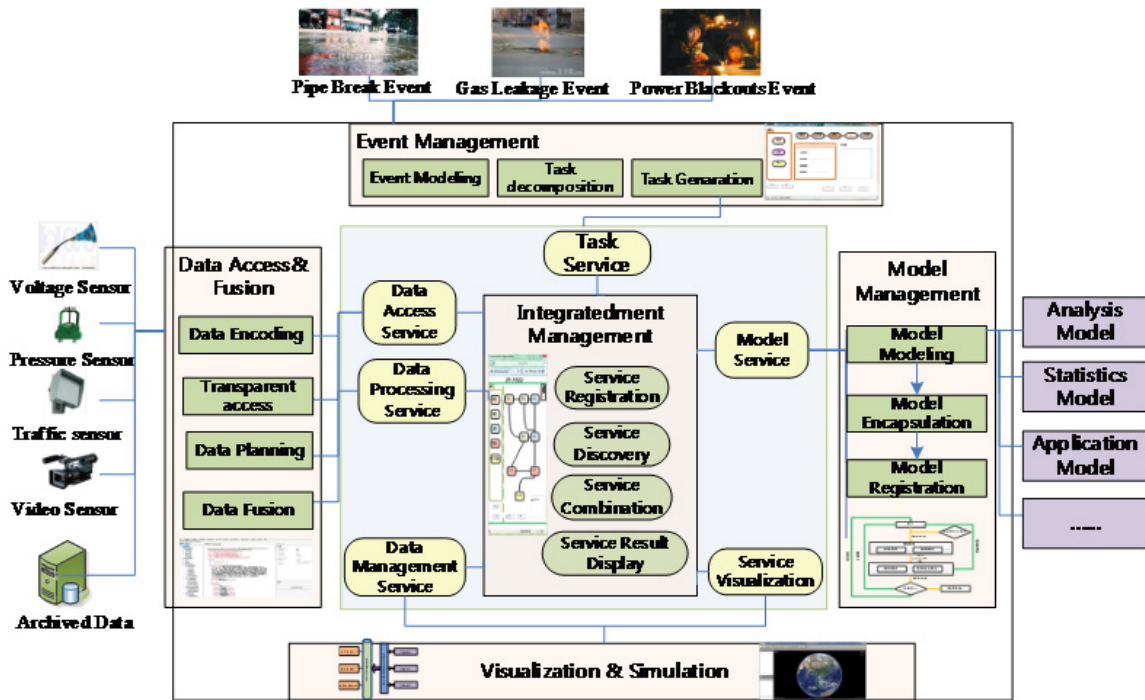


Figure 10 – Framework of the model web technology used in smart sustainable cities

## 3 Integrated management for smart sustainable cities

### 3.1 Overview

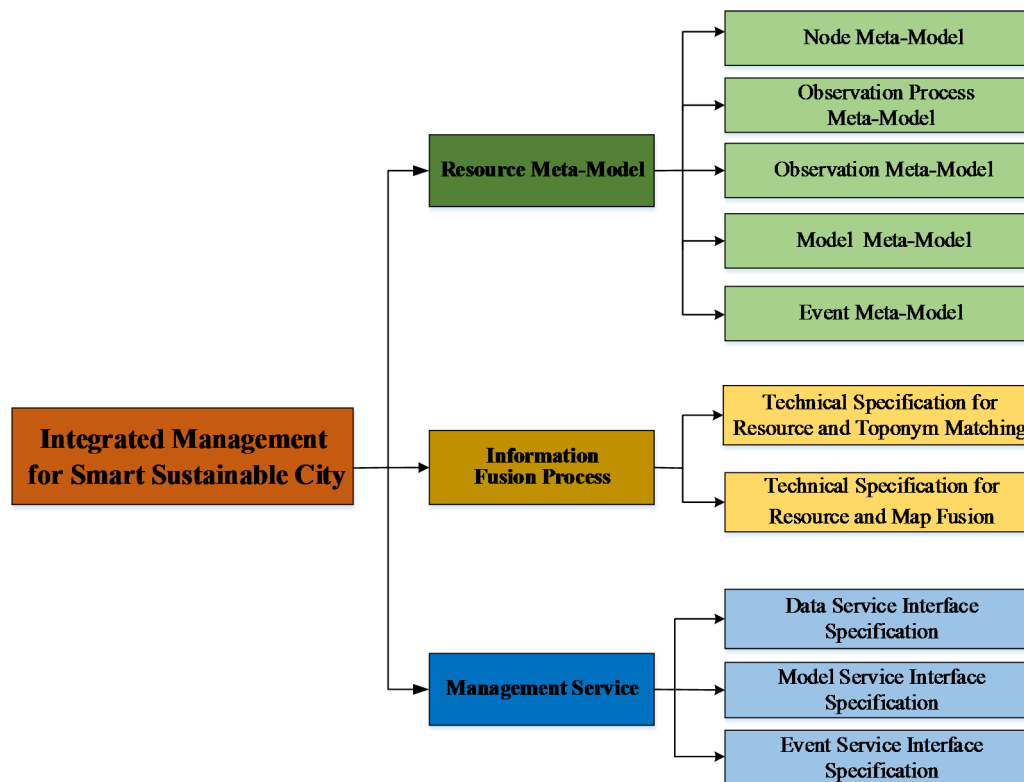
With the continuous development of smart sustainable cities, the categories and forms of information resources are greatly expanded. A large number of heterogeneous information resources, like nodes, sensors, observations and events, are involved in IMSSC. The relationship of these information resources is complicated, sometimes complementary, reinforced or redundant. However, there is no technical proposal to manage them in an integrated way so that the redundant information can be eliminated, the weakness of one kind of information resources can be supplemented by another, and several information resources can be combined together to fulfil the tasks more effectively. A technical proposal for IMSSC is put forward in Figure 11. In this proposal, the sensors, observations, models and nodes are encoded and managed in a uniform way in advance, and when events occur, the service center will invoke the sensors, observations, models as well as the nodes to perform the corresponding missions as predefined.



**Figure 11 – Technical proposal for the integrated management of smart sustainable cities**

To complete the smooth realization of IMSSC, a set of theoretical foundation is needed, including meta-models, fusion processing workflows, and sharing services. Meta-models are aimed to implement the modelling of these information resources, including nodes, sensors, observations and events, demonstrating their capabilities in different aspects and providing the basis for capability enhancement. Workflows of information resource fusion processing are used to guide the implementation of capability enhancement. Service interfaces are intended for unified and efficient sharing of information, offering decision support for municipal authorities during emergencies. In the infrastructure, the meta-models are the basis and premise for the fusion processing workflows and sharing services, including node metadata [b-Chenh]; observation process metadata [b-Cheng], [b-Chenf], [b-Hu], and [b-OGCc]; observation metadata [b-Di], [b-ISO 19156], [b-OGCd], and [b-OGCg]; event metadata [b-Fan], and [b-OGCe], and model metadata [b-Visconti]. The fusion processing workflows are means to enhance the capabilities of the information resources modelled by the meta-models and shared by the sharing services, consisting of the technical specifications for fusing resources with toponym [b-Smart], and maps separately [b-Chanier]. The sharing service interface specifications [b-Chenb] are ways to share and manage the modelling results of information resource and fusion processing results, composed of the data [b-Chenc], [b-Chend], [b-Chene], and [b-OGCa], as well as model, and event service interface specifications [b-OGCb], and [b-OGCf]. The organization of the theoretical foundation for the integrated management under the smart sustainable cities environment is described in Figure 12:





**Figure 12 – Organization of the theories for integrated resource management under the smart sustainable cities environment**

## 3.2 Meta-models for resource integrating

There are five meta-models for resource integrating, namely node meta-model, observation process meta-model, observation data meta-model, model meta-model and event meta-model. Only the aspects of the node meta-model are elaborated in detail: background, scope, and content.

### 3.2.1 Node meta-model

#### 3.2.1.1 Background

In the present sensor web applications, especially the emergency response and decision support applications for land surface events on the earth, a series of problems exist, including the "more" and "less" sensor web resources, insufficient data processing capability, and the lack of service-focused model [b-Chena]. How to make people be able to access observation resources in a transparent, efficient and customized manner, and implement the online information fusion, data assimilation, dynamic management, as well as intelligent service for the resources is still a challenge. Thus, there is an urgent need for a unified management model to organize and allocate the sensor web resources [b-Liang]. The node meta-model is aimed at providing an open and unified sensor web node information model in order to realize the unified description for the inherent features of the nodes. Through the node meta-model, it becomes clear which nodes have the capability of completing data processing and serving needed for a certain task, as well as the working state, timeliness, and geolocation of which nodes are able to meet the task requirements. The node meta-model facilitates the efficient management and allocations for heterogeneous nodes.

### 3.2.1.2 Scope

The node meta-model defines the sharing metadata for node resources in the comprehensive smart cities management. The metadata content is confined to the unified description for inherent properties, capabilities, and status and space-time information of the nodes. The structure, physical characteristics of the nodes themselves, as well as node observation data and the following processing and services are all excluded.

The meta-model can be applied in the integrated discovery and sharing, integrated management, planning, dispatching, as well as collaborative observing for all kinds of nodes. The specific application scope of the node meta-model is given in Figure 13.

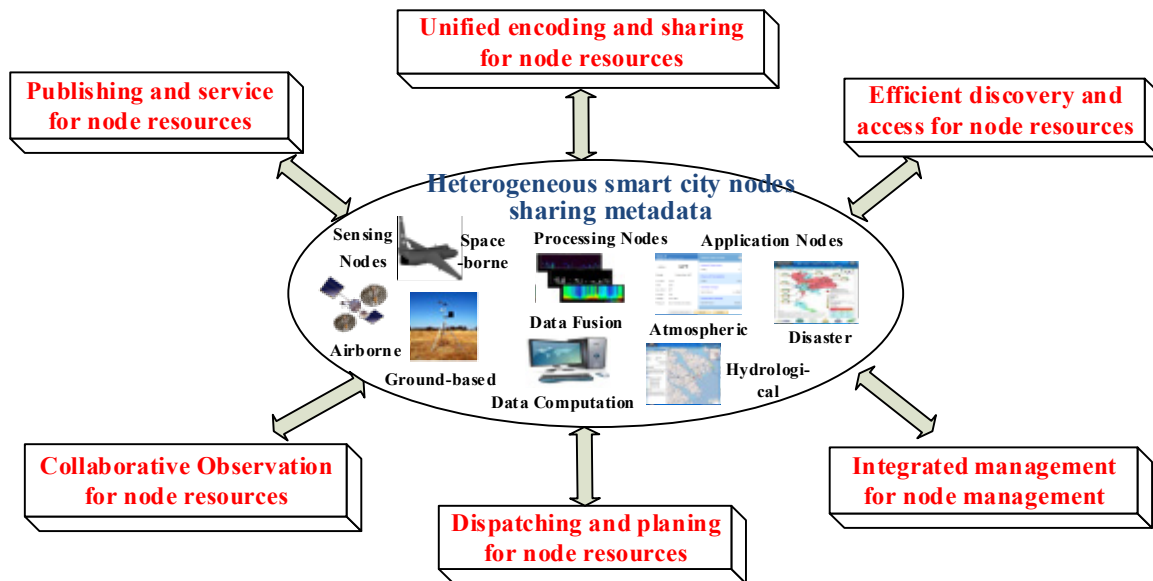


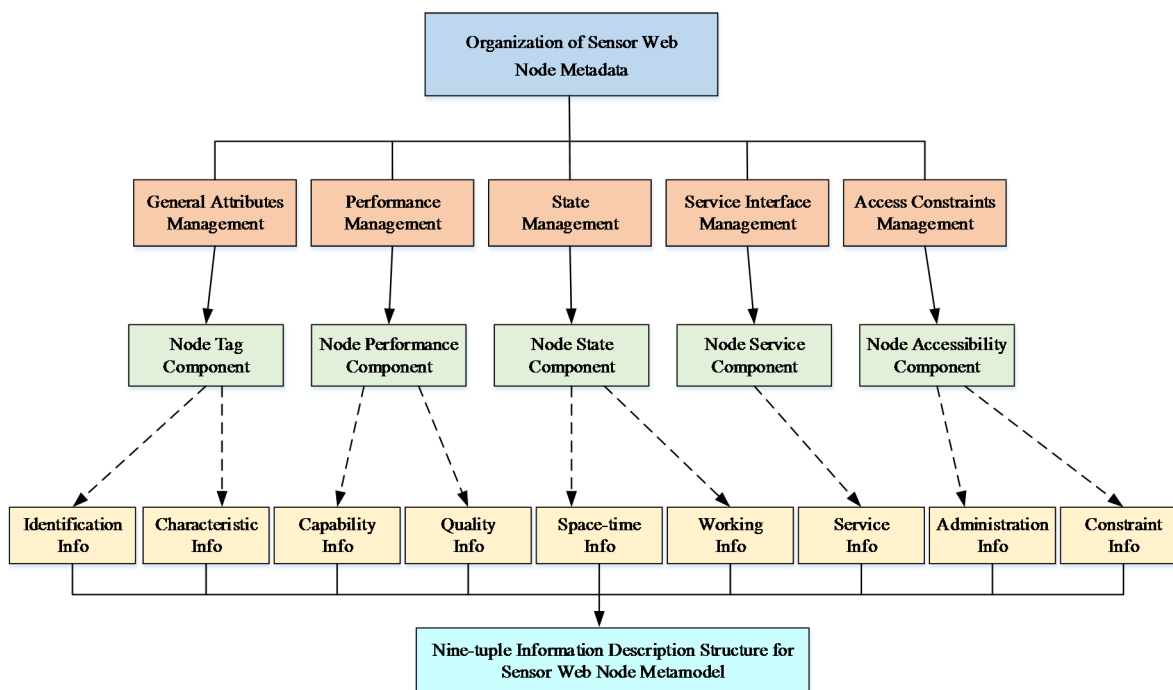
Figure 13 – Application scope for node meta-model

### 3.2.1.3 Content

Based on the node description components and different metadata requirements from all kinds of nodes, the node metadata is organized into the general information description framework, with five components, including the sensor tag, performance, state, service and accessibility, and a nine-tuple structure [b-ISO 19115-2]. The node meta-model is shown as follows:

Node metadata = {Identification, Characteristics, Capability, Quality, Space-time, Working, Service, Administration, Constraint}.

Among all the meta-model components, identification and characteristics information are tessellations for sensor tag component, capability and quality information for performance, service information for service, and administration and constraint for accessibility. The relationship between the five components and the nine-tuple structure is demonstrated in Figure 14 [b-Chenh].



**Figure 14 – Description structure for the nine-tuple smart sustainable cities node information**

- 1) Identification information: such information includes keywords and the node name, identity (ID), type, level, and dynamic feature, which describe the general information of a node for uniquely identifying a node.
- 2) Characteristics information: such information includes node function, suitable fields, core units, platform environment, communication fabric, and input and output features that describe the characteristic information of a node. The core units refer to sensor, processing algorithm, or service to different types of nodes.
- 3) Capability information: such information includes function, communication, capability, and resource consumption capability features. Heterogeneous nodes have different function capabilities and need to have extended metadata according to a specific node type.
- 4) Quality information: such information includes product quality and quality of service (QoS) features. Various nodes have different quality indicators and need to have extended product quality metadata according to a specific node type.
- 5) Space-time information: such information includes time and space referencing framework, location, and valid time features that describe the real location and time of a node in dynamic observation systems.
- 6) Working information: such information includes the use state, fault state, and resource consumption, which can determine whether a node is available at a task moment.
- 7) Service information: such information includes the service name, type, address, parameters, provider, and mode features that describe the metadata contents of node service interfaces. The relation among the services of a service combination can be represented through the service connection feature.
- 8) Administration information: such information includes contact, history, and document features that note the important information usable for node administration management.
- 9) Constraint information: such information includes access level, legal constraint and security constraint features, which affect the accessibility of a node.

### 3.3 Technical specifications for fusion process

There are two technical specifications for fusion process, namely resource and toponym matching specification as well as resource and map fusion specification. Only the aspects of the resource and toponym matching specification are explained in detail: background, scope, and content.

#### 3.3.1 Resource and toponym matching specification

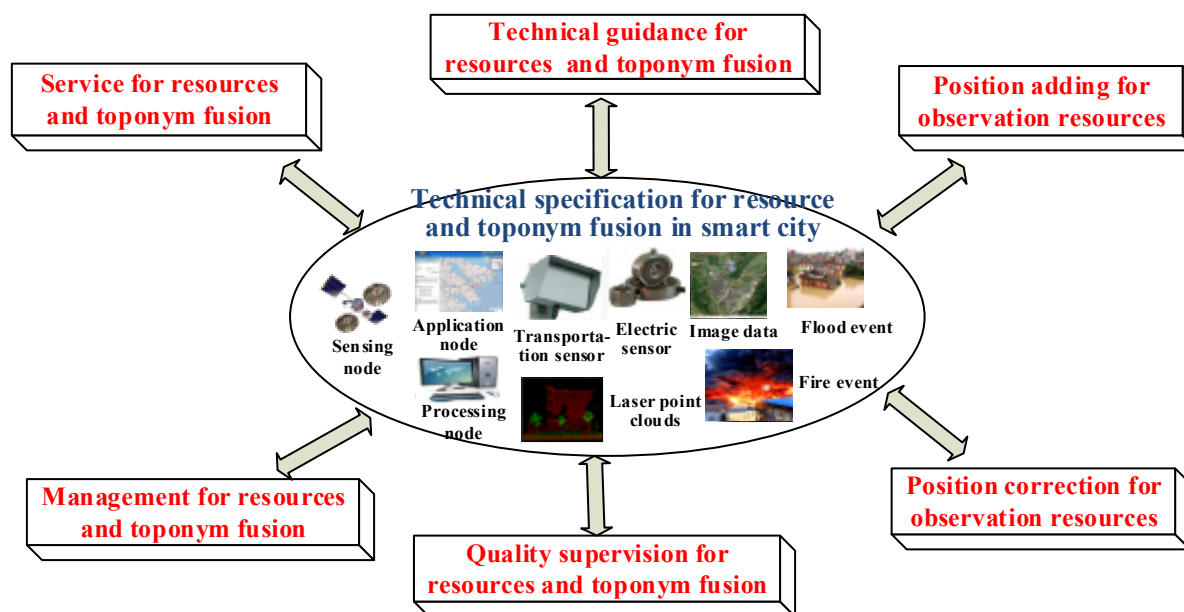
##### 3.3.1.1 Background

Toponym is important in the GIS databases, and it can assist users in the searching, interpreting and analyzing of the geographic data. Meanwhile, in the Internet of things and construction of smart cities, the scanning, imaging and radar type sensors, aerial and space images as well as ground-based observations, and disaster, accident calamity, public hygiene event as well as welfare event are all carriers of information resources. However, they lack the association with the actual place names, resulting in the difficulty of being applied in the smart sustainable cities. The research of how to match up and fuse nodes, sensors, observations, and events with toponym database is able to label geographic locations, and is beneficial to the unified management, efficient discovery, time and space pattern mining, as well as visualization for all these observation resources. The technical specification for resource and toponym database matching in the integrated management for smart sustainable cities is designed to formulate a unified and efficient workflow to realize the fusion of resources and their toponym. Through the fusion, the actual place names can be assigned to the corresponding nodes, sensors, observations and events, which will assist in expressing and understanding the observation information.

##### 3.3.1.2 Scope

The technical specification for resources and the toponym database matching in IMSSC provides a unified workflow for observation resources matching up with the toponym database, including matching the nodes, sensors, observations and event resources up with the toponym database. The technical specification is limited to matching nodes, sensors, observations and event resources up with the toponym database. However, the structure and characteristics information of the resources and toponym database themselves as well as the data processing method and service are not included.

The interface specification of fusion process can be used to provide technical guidance for matching the observation resources up with the toponym database, add and correct positions for observation resources, implement quality supervision as well as efficient management for resources and toponym and so on. The concrete application scope is depicted in Figure 15.



**Figure 15 – Application scope of technical specification for resource and toponym database matching in the integrated management for smart sustainable cities**

### 3.3.1.3 Content

The fusion of nodes and the toponym database, assigning the actual place name information to nodes, will make it convenient to overlay nodes on maps or images, and increase the efficiency of sensor accessing and dispatching. Fusing sensors with the toponym database will facilitate the graphical display of sensors on the map, and provide data support for sensor planning, arrangements, as well as intensive observations under emergencies. The observations fusing with the toponym database, mainly adding observed properties, will make the demonstration of the data's geographic positions more intuitive, and convenient to be invoked at any time. The fusion between events and toponym, adding graphic position labels for events, will contribute to map display, pattern of spatial distribution, and causality inferring for events. The technical workflow of matching resources up with the toponym database in IMSSC is shown in Figure 16 [b-Smart].

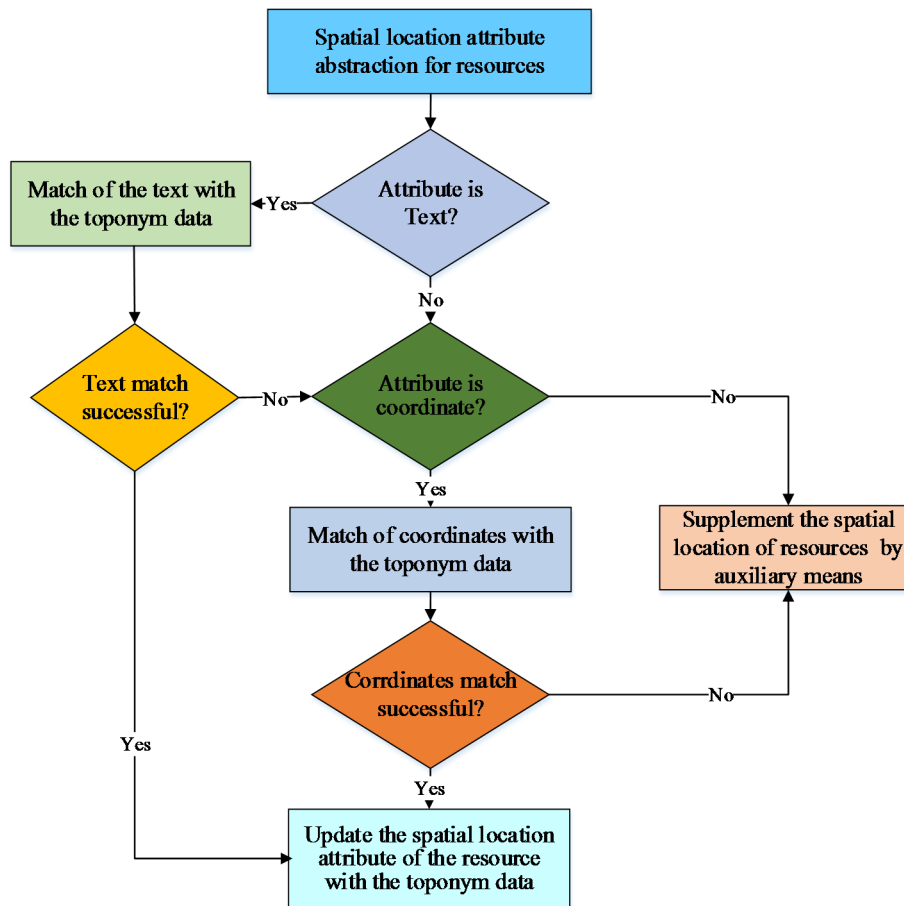


Figure 16 – Technical workflow of matching resources up with the toponym database in the integrated management for smart sustainable cities

### 3.4 Interface specifications for management service

There are three service technical interface specifications for management service, namely model service interface specification, data service interface specification, and event service interface specification. Only the aspects of the model service interface specification are described in detail: background, scope, and content.

#### 3.4.1 Model service interface specification

##### 3.4.1.1 Background

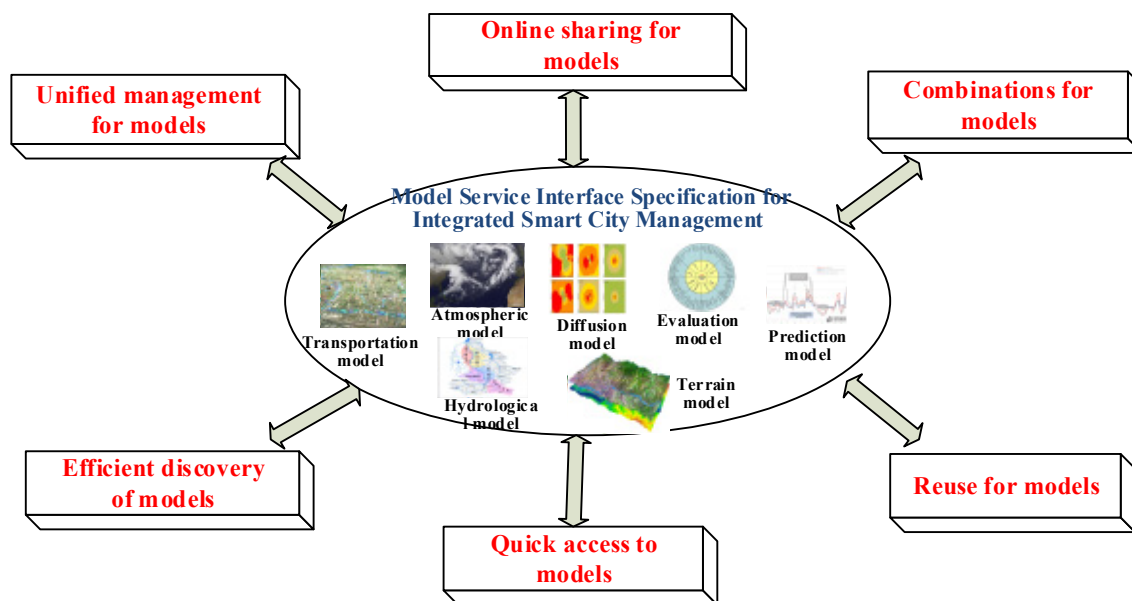
In IMSSC, all departmental applications, such as urban construction, water conservancy, electric power, environmental protection, transportation, and fire-fighting, need to be combined with concrete models. Nevertheless, research is limited to some application fields, and systems must be modified or even re-developed when new problems appear. It will take more time and money to restrict the models' application in IMSSC [b-Nativi]. The model service interface specification proposed in this Technical Report offers a general and unified service interface, and with the storage and invoke for the models separated from the users, the sharing, management as well as interoperability for heterogeneous models or model chains can be implemented.



### 3.4.1.2 Scope

Through the model service interface, model providers can perform the registration, insertion and publishing of the model metadata; model consumers are able to query model metadata information, find the model in need and finally discover, access and invoke the model according to the model ID returned.

The model service interface specification can be exploited for the publishing, sharing and reuse of the models. The concrete application scope of the model service interface specification is depicted in Figure 17.



**Figure 17 – Application scope of the model service interface specification under the environment of the integrated management for smart sustainable cities**

### 3.4.1.3 Content

The model service under the smart city environment is an open interface, and it acts as an intermediate agent between the user and the model storage warehouse. A web service interface is defined in the service interface specification, in which queries about the model metadata, input and output, as well as representation for models are allowed. Moreover, the methods of registering new models, deleting existing models, as well as inquiring about new models are all defined in the model service interface specification [b-de Castro]. There are three kinds of operations in the interface specification, namely core, transactional, and enhanced operation. Core operations include the GetCapabilities, DescribeModel, and ExecuteModel operation. Transactional operations consist of the InsertModel, DeleteModel, and UpdateModel operation. Enhanced operations are composed of the GetFieldOfInterest and GetModelByFunction operation. Among all these operations, only the three core operations are mandatory, while the others are optional. The element structure for the model service interface specification is as explained in Table 1.

**Table 1 – Elements of the integrated smart sustainable cities management model service interface specification**

Interface specification name	Operation type	Operation name	Operation definition	Mandatory or not
Model service interface specification of the integrated management for smart sustainable cities	Core operations	GetCapabilities	Provides access to metadata and detailed information about the models available by a model server.	Yes
		DescribeModel	Enables querying of metadata about the models and model chains available by a model server.	Yes
		ExecuteModel	Provides the execution of models.	Yes
	Transactional operations	InsertModel	Allows registration of new models at the model server.	No
		DeleteModel	Allows the deletion of registered models and all their associated algorithms.	No
		UpdateModel	Allows the update of model parameters and functions.	No
	Enhanced operations	GetFieldOfInterest	Provides access to models from a model service by passing only the field of interest of a user.	No
		GetModelByFunction	Provides access to models from a model service by passing only the expected function of a user.	No

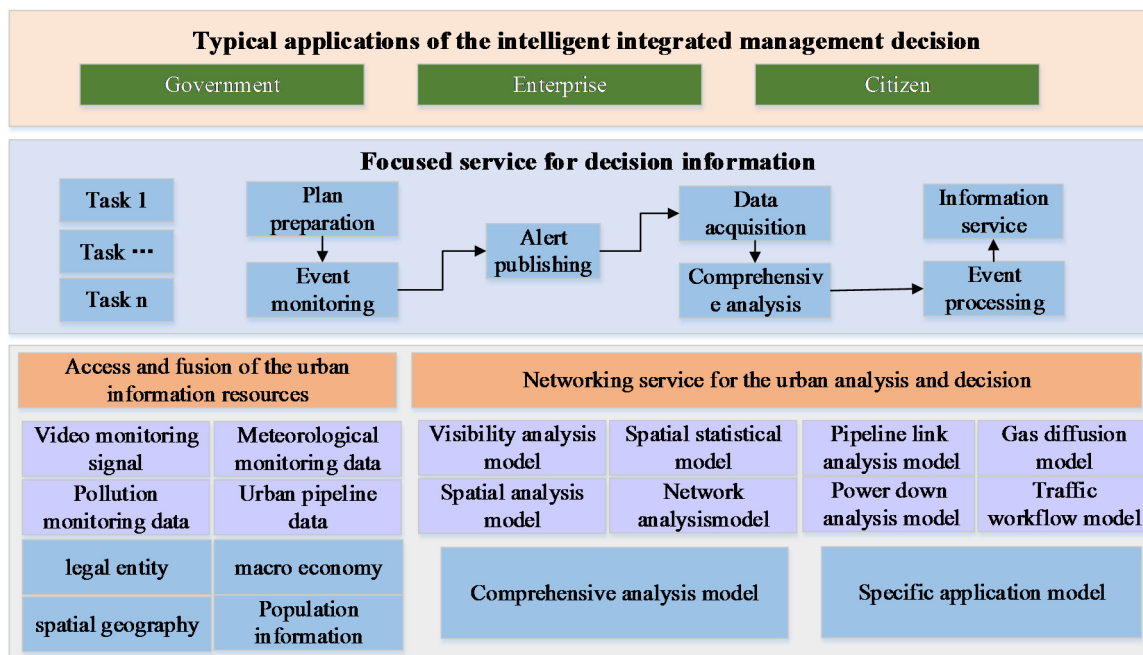
## 4 Instances of the integrated management for smart sustainable cities

### 4.1 Daily management

The daily management for smart sustainable cities can be implemented following the steps described herein. Firstly, the access of the monitoring data and processing models of different municipal departments can be achieved by encoding the information resources, like the nodes, sensors, observation data and models, according to the meta-model proposed in section 3.1. Secondly, by referring to the fusion processing technical specification in section 3.2, the integration of different information resources can be realized, together with a higher level of acquired information. Thirdly, the unified management service interface specification can be employed to issue and share nodes, sensors, models and other information resources. When needed, users can access and obtain the corresponding data or models quickly via the uniform service interfaces.

### 4.2 Emergency response management

The access and integration of all kinds of city monitoring data resources from different departments can be realized by conforming to the theories proposed in this Technical Report. Via the technologies of model representation, registration, combination, and optimization, and combination of the available data resources, the model-driven data access can be formed with the model selection. The parameters are optimized, and the dual-directional coupling between the data and the models is formed. By encapsulating the data and models into web services, and linking them with the decision information requirements from different users, and by combining concrete city decision task execution workflows, the active and focused service of a city decision information can be formed. Finally, the typical application of IMSSC will be established, as demonstrated in Figure 18.



**Figure 18 – Technical roadmap for the typical applications of integrated management intelligent decision in smart cities**

Aimed at different application topics from multilevel inter-agency intelligent decisions, such as water leakage, power interruption, gas pipeline leakage and so on, the spatial-temporal intelligent

analysis and decision model database should be built including general analysis model (visibility analysis model, spatial statistical model, spatial analysis model, and network analysis model), and specific application models (pipeline connection analysis model, gas diffusion model, power down analysis model, etc.).

Model information should be expressed in a unified way, so that the models can be conveniently managed and coupled, and the output of various models can be easily fused. In addition, the model registration center for cities should be established based on the representation model so that the model registration and discovery can be realized consequently. Moreover, using the combination and optimization technology, the abstract and instantiated model chains can be created for decision support in different applications. Through the execution of the model chains, the decision result can be produced, providing support for multilevel intelligent decisions.

When faced with emergency events, the focus is mainly on the task generation, plan preparation, and event responding. The theories proposed in this Technical Report can be used to provide different data, models and services for different stages, respectively.

For example, when a pipeline explosion event occurs in the task generation stage, the network and spatial analysis model, as well as the pipeline network and topography data can be adopted to acquire the location, the severity level, and other important information of the event; then the task requirements can be extracted. In the plan preparation stage, by accessing the corresponding data from the departments transparently, and performing a comprehensive analysis on the resources, mainly basic geographic data, topography data, data diffusion model, overlay analysis model, and network analysis model, the development tendency of the event, the first responders and the emergency facility distribution and other information can be obtained, providing the basis for making the correct emergency response plan. In the event responding stage, using the road network and real-time traffic information, and combining the optimal path, buffer analysis and other models, provides valuable support for a fast response to the emergency. When a multilevel emergency occurs, different service-focused measures should be taken to meet the requirements of the different users, namely municipalities, enterprises and citizens. Municipalities need all the city departments to work collaboratively through the task creation, plan preparation, event monitoring, alert publishing, data acquaintance, comprehensive analysis, event handling, and information service, to realize the focused service of the decision information. The relative model and data analysis is performed in the task creation stage, together with the task requirements extracted. For example, the gas company is informed during the plan preparation stage to monitor the gas leakage event as well as the situation, locate the event source, feedback the information to the command center, and issue the alert information to the environmental protection, fire-fighting, transportation, communication, surveying and mapping, health care, and public security departments. After that, it is necessary to assess the staff, facilities and equipment conditions of the different departments, and instruct each concerned department with the appropriate event handling methods to respond promptly. Finally, a communication should be issued to the citizens to inform them about the emergency measures put in place. Through the active focused service described above, decision support for smart pipeline in cities can be provided, proving the efficiency of IMSSC.

## 5 Conclusions

---

This Technical Report provides a proposal for integrated management for smart sustainable cities with the aim of better coordinating and managing city infrastructure and operations, as well as citizen interactions. The theoretical foundation of IMSSC is depicted, including the meta-models for

resources integration (node meta-model, observation process meta-model, observation data meta-model, event meta-model, and model meta-model), fusion processing workflow (fusion of resources and toponym, and maps separately), and service interface specification (observation service, model service, and event service).

Taking into consideration the management challenges faced by cities worldwide, this Technical Report describes the advantages of adopting an integrated management system in order to make cities function more efficiently and citizens live more conveniently.

This Technical Report provides practical guidance to help urban planners make cities smarter and more sustainable. Adopting the proposed technical solutions, the overall efficiency of information resource collecting and sharing, as well as the effectiveness of information fusion processing will be considerably enhanced, facilitating IMSSC.

The next step is to put theory into practice, and to improve it according to the specific problems of every urban environment. To this end, it is essential to acknowledge the importance of turning the requirements presented here into international standards in order to multiply the benefits of this approach across all cities worldwide.

## Bibliography

- [b-Balazinska] Balazinska, M., Deshpande, A., J. Franklin M., B. Gibbons, P., Gray, J., Nath, S., Hansen, M., Liebhold, M., Szalay, A., and Tao, V., *Data Management in the worldwide sensor web* [J]. IEEE Pervasive Computing, 2010, 6(2): 30-40. [Online] Retrieved from: [22.05.2014]
- [b-Chanier] Chanier, F, Checchin, P., Blanc, C., et al., *Map fusion based on a multi-map SLAM framework* [C]//Multisensor Fusion and Integration for Intelligent Systems, 2008. MFI 2008. IEEE International Conference on. IEEE, 2008: 533-538. [Online] Retrieved from: [18.12.2013]
- [b-Chena] Chen, C., and Helal, S., *Sifting Through the Jungle of Sensor Standards* [J], IEEE Pervasive Computing, 2008, 7:84-88. [Online] Retrieved from: [16.05.2014]
- [b-Chenb] Chen, N., Chen, Z., and Hu, C., *A capability matching and ontology reasoning method for high precision OGC web service discovery* [J], International Journal of Digital Earth, 2011, 4(6):449-470. [Online] Retrieved from: [23.02.2014]
- [b-Chenc] Chen, N., Di, L., Yu, G., and Gong, J., *Automatic on-demand data feed service for autochem based on reusable geo-processing workflow* [J], IEEE Journal of Selected Topics in Applied Earth Observations and Remote Sensing, 2010a, 3(4): 418-426. [Online] Retrieved from: [19.04.2014]
- [b-Chend] Chen, N., Di, L., Yu, G., Gong, J., and Wei, Y., *Use of ebRIM-based CSW with sensor observation services for registry and discovery of remote-sensing observations* [J], Computers & Geosciences, 2009a, 35: 360-372. [Online] Retrieved from: [27.02.2014]
- [b-Chene] Chen, N., Di, L., Yu, G. and Min, M., *A flexible geospatial sensor observation service for diverse sensor data based on Web service* [J], ISPRS Journal of Photogrammetry and Remote Sensing, 2009b, 64(2): 234-242. [Online] Retrieved from: [12.05.2014]
- [b-Chenf] Chen, N., and Hu, C., *A sharable and interoperable meta-model for atmospheric satellite sensors and observations* [J], IEEE Journal of Selected Topics in Applied Earth Observation And Remote Sensing, 2012, 5(5): 1519-1530. [Online] Retrieved from: [19.04.2014]
- [b-Cheng] Chen, N., Hu, C., Chen, Y., Wang, C., and Gong, J., *Using SensorML to construct a geoprocessing e-Science workflow model under a sensor web environment* [J], Computers & Geoscience, 2011, 11(27): 1016-1025. [Online] Retrieved from: [27.03.2014]
- [b-Chenh] Chen, N., Wang, K., Xiao, C., et al., *A heterogeneous sensor web node meta-model for the management of a flood monitoring system* [J], Environmental Modelling & Software, 2014, 54: 222-237. [Online] Retrieved from: [19.05.2014]
- [b-de Castro] de Castro, V., Marcos, E., and Cáceres, P., *A user service oriented method to model web information systems* [M]//Web Information Systems-WISE 2004. Springer Berlin Heidelberg, 2004: 41-52. [Online] Retrieved from: [15.04.2014]
- [b-Di] Di, L., Moe, K., and Yu, G., *Metadata requirements analysis for the emerging Sensor Web* [J], International Journal of Digital Earth, 2009, 2:3-17. [Online] Retrieved from: [19.03.2014]
- [b-ESTO] Report from the Earth Science Technology Office (ESTO), *Advanced Information Systems Technology (AIST) Sensor Web Technology Meeting* [R]. In 2007 Proceedings of ESTO/AIST Sensor Web Principal Investigator Meeting, San Diego, CA, February 2007, 13-14. [Online] Retrieved from: [16.04.2014]



- [b-Fan] Fan, M., Fan, H., Chen, N., Chen, Z., and Du, W., *Active on-demand service method based on event-driven architecture for geospatial data retrieval [J]*, *Computers & Geosciences*, 2013, 56:1-11. [Online] Retrieved from: [17.03.2014]
- [b-Hu] Hu, C., Chen, N., and Li, J., *Geospatial Web-based Sensor Information Model for Integrating Satellite Observation: An Example in The Field of Flood Disaster Management [J]*, *Photogrammetric Engineering & Remote Sensing*, 2013, 79(10):915-927. [Online] Retrieved from: [21.04.2014]
- [b-ISO 19115-2] ISO 19115-2:2009, *Geographic information – Metadata – Part 2: Extensions for imagery and gridded data*.
- [b-ISO 19156] ISO 19156:2011, *Geographic information – Observations and measurements*.
- [b-Liang] Liang, S., and Tao, C., *A distributed geospatial infrastructure for Sensor Web [J]*, *Computers & Geoscience*, 2005, 31 (2), 221-231. [Online] Retrieved from: [12.04.2014]
- [b-Nama] Nam, T., and Pardo, T. A., *Conceptualizing smart city with dimensions of technology, people, and institutions[C]*//Proceedings of the 12th Annual International Digital Government Research Conference: Digital Government Innovation in Challenging Times. ACM, 2011: 282-291. [Online] Retrieved from: [13.03.2014]
- [b-Namb] Nam, T., and Pardo, T.A., *Smart city as urban innovation: Focusing on management, policy, and context [C]*//Proceedings of the 5th International Conference on Theory and Practice of Electronic Governance. ACM, 2011: 185-194. [Online] Retrieved from: [14.05.2014]
- [b-Nativi] Nativi, S., Mazzetti, P., and Geller, G.N., *Environmental model access and interoperability: The GEO Model Web initiative [J]*, *Environmental Modelling & Software*, 2013, 39: 214-228. [Online] Retrieved from: [18.05.2014]
- [b-OGCa] OGC 06-009r6, *OpenGIS Sensor observation service implementation specification [S]* (Version 1.0). Wayland, MA, USA: Open Geospatial Consortium, 2007c. [Online] Retrieved from: [21.03.2014]
- [b-OGCb] OGC 06-028r3, *OpenGIS Sensor Alert Service Implementation Specification [S]* (Version 0.9.0). Wayland, MA, USA: Open Geospatial Consortium, 2007b. [Online] Retrieved from: [26.02.2014]
- [b-OGCc] OGC 07-000, *OpenGIS Sensor Model Language (SensorML) Implementation Specification [S]* (Version 1.0.0). Wayland, MA, USA: Open Geospatial Consortium, 2007a. [Online] Retrieved from: [09.04.2014]
- [b-OGCd] OGC 08-094r1, *OpenGIS SWE Common Data Model Encoding Standard [S]* (Version 2.0.0). Wayland, MA, USA: Open Geospatial Consortium, 2011a. [Online] Retrieved from: [03.05.2014]
- [b-OGCe] OGC 08-132, *OpenGIS Event Pattern Markup Language (EML) [S]* (Version 0.3.0). Wayland, MA, USA: Open Geospatial Consortium, 2008a. [Online] Retrieved from: [14.03.2014]
- [b-OGCf] OGC 08-133, *OpenGIS Sensor Event Service Interface Specification [S]* (proposed) (Version 0.3.0). Wayland, MA, USA: Open Geospatial Consortium, 2008b. [Online] Retrieved from: [24.02.2014]
- [b-OGCg] OGC 10-025r1, *OpenGIS Observations and Measurements-XML Implementation [S]* (Version 2.0). Wayland, MA, USA: Open Geospatial Consortium, 2011b. [Online] Retrieved from: [26.12.2013]

- [b-Simonis] Simonis, I., *OGC® Sensor Web Enablement Architecture [R]*, OGC White Paper, 2008. [Online] Retrieved from: [10.05.2014]
- [b-Smart] Smart, P.D., Jones, C.B., and Twaroch, F.A., *Multi-source toponym data integration and mediation for a meta-gazetteer service [M]*//Geographic Information Science. Springer Berlin Heidelberg, 2010: 234-248. [Online] Retrieved from: [21.11.2013]
- [b-Toppeta] Toppeta, D., *The smart city vision: how innovation and ICT can build smart, "livable", sustainable cities [J]*. The Innovation Knowledge Foundation, 2010. [Online] Retrieved from: [14.10.2013]
- [b-Visconti] Visconti, M., and Cook, C.R. (2002), *A meta-model framework for software process modeling. Product Focused Software Process Improvement*, Springer Berlin Heidelberg, 532-545. [Online] Retrieved from: [15.03.2014]

## Annex

### Abbreviation and acronyms

This Technical Report uses the following abbreviations:

4A	Anytime, Anybody, Anywhere, Anything
4R	Right time, Right body, Right place, Right thing
EML	Event Pattern Markup Language
ESTO	Earth Science Technology Office
GIS	Geographic Information System
GPS	Global Positioning System
ID	Identification
ICT	Information and Communication Technology
IMSCC	Integrated Management for Smart Sustainable Cities
IoT	Internet of Things
ISO	International Organization for Standardization
ITU	International Telecommunication Union
OGC	Open Geospatial Consortium
QoS	Quality of Service
RFID	Radio Frequency Identification
SSC	Smart Sustainable Cities
SES	Sensor Event Service
SOS	Sensor Observation Service
SPS	Sensor Planning Service
UAV	Unmanned Aerial Vehicle
WCS	Web Coverage Service
WMS	Web Map Service
WPS	Web Processing Service









# 3.10

## Anonymization infrastructure and open data in smart sustainable cities

Technical Report



## Acknowledgements

This Technical Report was researched and authored by Jie Chang (China Telecom), Lei Gu (China Telecom), Wei Liu (Shanghai Library), Kanae Matsui (Keio University), Hiroaki Nishi (Keio University) and Cuijuan Xia (Shanghai Library).

The authors wish to extend their gratitude to Ramy Ahmed (NTRA Egypt), Takafumi Hashitani (Fujitsu), Michael Mulquin (IS Communications), Ziqin Sang (Fiberhome Technologies Group), Mythili Menon (University of Geneva) and Junnosuke Sugiura (Fujitsu) for their valuable inputs and support.

Authors and contributors are listed in alphabetical order.

The authors acknowledge the guidance and support from all the members of the ITU-T Focus Group on Smart Sustainable Cities (FG-SSC) Management Team.

Additional information and materials relating to this Technical Report can be found at: [www.itu.int/itu-t/climatechange](http://www.itu.int/itu-t/climatechange). If you would like to provide any additional information, please contact Cristina Bueti (ITU) at [tsbsg5@itu.int](mailto:tsbsg5@itu.int).

## Table of Contents

		Page
<b>1</b>	<b>Introduction .....</b>	<b>688</b>
1.1	Scope .....	688
1.2	Background.....	688
<b>2</b>	<b>The demand of open data in SSC .....</b>	<b>691</b>
2.1	The Contents of open data.....	691
2.2	The objective of open data.....	693
2.3	Relationship between open data and smart sustainable cities .....	694
<b>3</b>	<b>The framework of open data .....</b>	<b>694</b>
3.1	The principles of overall design.....	694
3.2	The framework of overall design.....	695
<b>4</b>	<b>Open data handling in SSC.....</b>	<b>699</b>
4.1	Barriers and constraints in open data.....	699
4.2	Security protection and privacy preservation of open data .....	701
4.3	Policy and regulation .....	702
<b>5</b>	<b>Technologies related to open data in SSC .....</b>	<b>703</b>
5.1	Metadata management.....	703
5.2	Linked data .....	704
5.3	Data visualization .....	707
5.4	Social networks.....	709
5.5	Anonymization technology.....	710
<b>6</b>	<b>The management of open data in SSC .....</b>	<b>711</b>
6.1	Executive institution management .....	711
6.2	User management .....	712
6.3	Quality management.....	712
6.4	Security management .....	714
6.5	Operation management .....	716
<b>7</b>	<b>Use cases .....</b>	<b>718</b>
7.1	Case study 1. Data.gov .....	719
7.2	Case study 2. Data.gov.uk .....	721
7.3	IT dashboard.....	722
7.4	Open data movement in China .....	723
7.5	Open data services with privacy data and anonymization .....	725
<b>8</b>	<b>Expected (anonymous) applications of open data in smart sustainable cities .....</b>	<b>728</b>
8.1	Application of open data on smart forecasts.....	728

	<b>Page</b>
8.2 Data anonymization for smart sustainable city.....	729
8.3 Application of anonymization method for smart metering .....	734
8.4 Infrastructure of secondary use of data.....	735
<b>9 Milestone .....</b>	<b>741</b>
<b>Annex A – Application of anonymization for disaster recovery .....</b>	<b>743</b>
<b>Annex B – Abbreviations .....</b>	<b>745</b>
<b>Appendix I – Bibliography .....</b>	<b>747</b>

## Anonymization infrastructure and open data in smart sustainable cities

### Overview

ITU-T Study Group 5 has established a new Focus Group on Smart Sustainable Cities (FG-SSC) to assess the standardization requirements of cities aiming to boost their social, economic and environmental sustainability through the integration of information and communication technologies (ICTs) in their infrastructures and operations.

This Technical Report focus on anonymization infrastructure and open data in smart sustainable cities (SSC), including the demand of open data in SSC, the framework of open data, the handling of open data in SSC, the technology of open data in SSC and the management of open data in SSC. Nevertheless, fruitful application examples are provided as use cases and expected (anonymous) applications of open data in SSC as well as anonymous application for disaster recovery.

### Executive summary

Focus Group on Smart Sustainable Cities (FG-SSC) has embarked on a journey for integration of open data and adoption of anonymization techniques for future smart sustainable cities.

This Technical Report has been specifically written for city officials, town planners, enterprise managers, developers, infrastructure providers, service providers, network operators, and citizens with the ultimate aim of ensuring data protection and improving data availability within their city of interest.

Open data is a current movement which requires machine-readable data to be freely available to everyone to use and republish as they wish, without restrictions of copyright, patents or other mechanisms of control. Currently, the open data system is utilized and is in high demand for creating new services from the level of local community to government. However, in order to beneficially utilize the open data, excessive exposure of private information which maybe included in the open data should be mitigated. Despite this need for protection of certain types of data, there are only few studies on open data utilization for smart sustainable cities (SSC), thereby making it difficult to get a comprehensive understanding of how these types of data can be both utilized and as well as protected.

To remedy the lack of credible research on this topic, this document provides a comprehensive study on open data in smart sustainable cities based on six aspects: (i) the demand of open data, (ii) the framework of open data, (iii) open data handling, (iv) the technology of open data, (v) the management of open data and (vi) application examples.

In addition, (a) practical methods of open data anonymization, (b) related information for the readers' understanding that highlight the relationship between open data, anonymization, and (iv) methods of how to utilize the information practically are also provided.

The Technical Report further examines the following; (1) definition of the open data and its characteristic features and objectives to understand what types of dangers are predicted, (2) open data framework that provides a general structure to produce and apply open data, (3) related technologies of open data for maintenance and application, (4) management methods of the open data from the aspects of usage, quality, security, and operation, (5) use cases of open data driven by governments for smart forecast, city management, metering many types of data with an anonymization technique using information communication technologies (ICT) infrastructure.

Further work will aim to analyse the impacts of open data anonymization and its effectiveness.

# 1 Introduction

---

## 1.1 Scope

This Technical Report proposes a summarized introduction on open data in smart sustainable cities and characterizes open data in smart sustainable cities based on the following six aspects (i) the demand of open data; (ii) the framework of open data; (iii) the constraint of open data; (iv) the technology of open data;(v) the management of open data; (vi) application examples of open data..

The target audience for this report include:

- City officials
- Town planners
- Enterprise manager
- Developers
- Infrastructure providers
- Service providers
- Network operators
- Citizens

This report provides guidance on implementation and promotes efficient deployment of open data in smart sustainable cities.

## 1.2 Background

Data is an extremely broad term, only slightly less vague than the nearly all-encompassing term information. Broadly speaking, data is structured information with potential for meaning.

Open data is data that can be freely used, re-used and redistributed by anyone – subject only, at most, to the requirement to attribute and share alike.

The term "open data" was initially used in the natural science field. The term was used to indicate basic and untreated scientific data. The first recognition of the use of "open data" to refer to a policy context, defining a scientific policy for a research project, was in the 1970s, during an international collaboration project in NASA<sup>1</sup>. The term "open data" becomes popular with the launch of open-data government initiatives such as Data.gov and Data.gov.uk<sup>2 3</sup>.

Currently, open data is an international movement that certain data should be freely available to everyone to use and republish as they wish, without restrictions of copyright, patents or other mechanisms of control. "Open" in this context usually refers to machine processed online resources that are easy to access and are put under free licenses. These free licenses enable the re-use of data by anyone for any purpose at no charge, requiring at most attribution.

---

<sup>1</sup> Yu, H.M.-T. 2012. Designing Software to Shape Open Government Policy. Princeton University.

<sup>2</sup> Parks, W. 1957. Open Government Principle: Applying the Right to Know Under the Constitution. The George Washington Law Review. 26, 1 (1957), 1–22.

<sup>3</sup> Nigel Shadbolt, Kieron O’Hara, Tim Berners-Lee, Nicholas Gibbins, Hugh Glaser, Wendy Hall and m.c. schraefel; *Linked Open Government Data: Lessons from Data.gov.uk*; IEEE INTELLIGENT SYSTEMS, May-June 2012 16-24 (Volume:27, Issue: 3).

A summary of the main criteria for open data include:

- **Availability and access:** The data must be available as a whole and at no more than a reasonable reproduction cost, preferably by downloading over the internet. The data must also be available in a convenient and modifiable form.
- **Re-use and redistribution:** The data must be provided under terms that permit re-use and redistribution including the intermixing with other datasets.
- **Universal participation:** Everyone must be able to use, re-use and redistribute. There should be no discrimination against fields of endeavor or against persons or groups. For example, 'non-commercial' restrictions that would prevent 'commercial' use or restrictions of use for certain purposes (e.g., only in education), are not allowed.

The idea of open government has an older origin, dated back to the early years following World War II at the time of the Great Depression in the U.S. There were increasing efforts to improve openness and the application of the right to know principle in the government during that period<sup>4</sup>. The various components of open data as applied by national government and the private sector are discussed in this section. Though the term "open data" is not as old as open government. Open government data (OGD) is an important part of open data, which can be traced back to the 2003 Public Sector Information Directive by The European Commission<sup>5</sup>. As of January 2014, more than 700,000 OGD datasets have been put online by national and local governments from more than 50 countries. The first one-stop-shop open data portal Data.gov ([www.data.gov](http://www.data.gov)) was launched in May 2009, as part of the open government directive of the Obama Administration. In the Memorandum on transparency and open government, issued on January 21, 2009, the President instructed the Director of the Office of Management and Budget (OMB) to issue an Open Government Directive. Responding to this memorandum is intended to direct executive departments and agencies to take specific actions to implement the principles of transparency, participation, and collaboration set forth in the President's Memorandum<sup>6</sup>. By June 2014, the US open government data portal has already published 104779 datasets in a machine-readable format with 80486 geographical sets, 24293 non-geographical sets and additional 341 tools. In January 2010, the British government launched Data.gov.uk. The British open data portal applied Comprehensive Knowledge Archive Network (CKAN), which is an open-source data management system (DMS) for powering data hubs and data portals. Thus, both open government and open data initiatives are not entirely a new concept.

At the conceptual level, the idea of openness has not significantly changed. For instance, the definition of open data in the current context still includes several important elements characterizing the preceding definition such as accessibility, availability, re-usability, re-distribution

---

<sup>4</sup> Li Ding, Timothy Lebo, John S. Erickson, Dominic DiFranzo, Gregory Todd Williams, Xian Li, James Michaelis, Alvaro Graves, Jin Guang Zheng, Zhenning Shangguan, Johanna Flores, Deborah L. McGuinness, James A. Hendler, *TWC LOGD: A portal for linked open government data ecosystems*; Web Semantics: Science, Services and Agents on the World Wide Web 9 (2011) 325–333.

<sup>5</sup> Leonida N. Mutuku and Jessica Colaco; *Increasing Kenyan Open Data Consumption: A Design Thinking Approach*; ICEGOV '12, October 22 - 25 2012, Albany, NY, USA.

<sup>6</sup> Lydia Marleny Prieto, Ana Carolina Rodríguez, Johanna Pimiento; *Implementation Framework for Open Data in Colombia*; ICEGOV '12, October 22 - 25 2012.



and participation<sup>7</sup> in combination with the emphasis on information technology factors such as machine-processable, non-proprietary and license-free<sup>8</sup>. On the other hand, openness as a concept is wider due to the emphasis on information technology usage and innovation.

Open scientific data (OSD) is the other important part of open data that came much before the inclusion of than OGD. The concept of open access to scientific data was institutionally established with the formation of the World Data Center system<sup>9 10</sup>, which was established by the International Council of Scientific Unions (now the International Council for Science) to minimize the risk of data loss as well as to maximize data accessibility, and further recommending that data be made available in machine-readable format<sup>11 12</sup>. Additionally, in 2004, the Science Ministers of nations of the Organization for Economic Co-operation and Development (OECD), signed a declaration which essentially states that all publicly funded archive data should be made publicly available<sup>13 14</sup>. In 2007, the OECD Principles and Guidelines for Access to Research Data from Public Funding was also published as a soft-law recommendation<sup>15</sup>.

Open Industrial Data (OID) resulted from recent initiatives, including:

- i) Vision 2020<sup>16</sup>: This is New York City's Comprehensive Waterfront Plan, which is led by the Department of City Planning of New York City. It sets the stage for expanded use of the waterfront for parks, housing and economic development, as well as waterways for transportation, recreation and natural habitats.
- ii) North Shore 2030: This initiative involves improving and reconnecting the North Shore's Unique and Historic Assets, and reviewing the city's industrial policies, including those relevant for Industrial Business Zones (IBZs) and Significant Maritime and Industrial Areas (SMIAs).

Another component of open data is open enterprise data (OED) which is best described as a way of doing business, forging strong relationships with the network of other organizations, customers, and potential customers. Alibaba, the China largest online B2C and B2B company, initiated Open Data Partnership Projects is an OED. In this project, ten open data partners are selected and desensitized online transaction data are open to these partners to innovate new applications.

---

<sup>7</sup> Committee on Scientific Accomplishments of Earth Observations from Space, National Research Council (2008). *Earth Observations from Space: The First 50 Years of Scientific Achievements*. The National Academies Press. p. 6. ISBN 0-309-11095-5. Retrieved 2010-11-24.

<sup>8</sup> World Data Center System (2009-09-18). *About the World Data Center System*. NOAA, National Geophysical Data Center. Retrieved 2010-11-24.

<sup>9</sup> OECD Declaration on Open Access to publicly funded data.

<sup>10</sup> OECD Principles and Guidelines for Access to Research Data from Public Funding.

<sup>11</sup> Please see: <http://www.nyc.gov/html/dcp/html/about/pr031411.shtml>.

<sup>12</sup> Ibid. OECD Principles and Guidelines for Access to Research Data from Public Funding.

<sup>13</sup> Auer. S. R, Bizer. C, Kobilarov, G., Lehmann. J, Cyganiak. R, Ives. Z. DBpedia: A Nucleus for a Web of Open Data. *The Semantic Web. Lecture Notes in Computer Science 4825*.

<sup>14</sup> Ibid. OECD Principles and Guidelines for Access to Research Data from Public Funding.

<sup>15</sup> Ibid. OECD Principles and Guidelines for Access to Research Data from Public Funding

<sup>16</sup> Joel Gurin, *Open Data Now: The Secret to Hot Startups, Smart Investing, Savvy Marketing, and Fast Innovation*, McGraw-Hill Professional.

Open data may need to be in a linked format or in another format that is easily readable by a computer (for example comma-separated values (.csv), Excel spreadsheet (.xls), or even PC-axis (.px) formats. In addition, all websites and text documents are included. However, scanned paper documents (.pdf), or other image files are not considered machine-readable.

With the rise of smart phones and their built-in sensors as well as web-apps, an increasing amount of personal data is being silently collected. Personal data—digital information about users' location, calls, web-searches, and preferences—is undoubtedly the “oil” of the new digital economy. However, the lack of access to the data makes it very hard if not impossible for an individual to understand and manage the risks associated with the collected data. Therefore, advancements in using and mining this data have to evolve in parallel with considerations about ownership and privacy.

## 2 The demand of open data in SSC

---

### 2.1 The contents of open data

Open data include various sources, including the open government data (OGD), open industrial data (OID), open enterprise data (OED) and open personal data (OPD). The OGD is the major part of open data because governments have accumulated a large amounts of data, have become the largest owner of data in terms of volume. Currently governments are assumed to publish open data to maximize public reuse, not only strengthen the transparency and promote efficiency and effectiveness in administration, but also to create economic opportunity and improve citizens' quality of life (QoL). The OGD includes geographical, environmental, weather, education, agriculture, and occupational safety as well as economic data, which help citizens to be more informed, and makes the government more efficient.

Open scientific data is another important source of open data, including experimental data, genomes, chemical compounds, mathematical and scientific formulae, medical data practice, bioscience biodiversity. Most of these fundamental researches are financed by governments and are funded for the purpose of disclosure of their works and face little limit for openness. Problems often arise in open industrial and enterprise data because these data are commercially valuable or can be aggregated into works of value. In these cases, access to, or reuse of the data is controlled by organizations, including access restrictions, licenses, copyright, patents and charges for access or reuse. It is important that the data are re-usable without requiring further permission though the types of reuse (such as the creation of derivative works) may be controlled by a license. Open personal data is also used in research projects. Companies like Microsoft and Yahoo investigate their consumer internet behavior in accordance with their respective user approval policies.

It is important to note that data management from new aspects, especially, anonymization is an essential from a viewpoint of achieving open data management in smart sustainable city.

Various institutions such as medical facilities, transportation facilities, and government agencies must manage large amounts of data, which may include private customer information, medical records, and transaction information. This data, commonly stored in electronic form, often contains sensitive personal information. These types of data are useful in smart sustainable city establishments, and are frequently necessary, to facilitate the provision of advanced services. However, stored data may contain a considerable amount of personal and sensitive information about individuals. This information may include age, addresses as well as more sensitive items such as financial data, medical records, personal preferences and history of behavior. In the interest of

the individuals, it is essential that the data containing sensitive information should be protected from unauthorized use.

Contrastingly, the organizations should provide the privacy data by transferring the data to useful services in smart sustainable cities. In providing the data, preserving privacy at a required level should be prioritized. It has the possibility that the two different data, generated by suitable anonymization process to the required anonymization level, reveal the original plain data. This situation can be harmful in publishing data even if the data is appropriately anonymized. Moreover, the following information is needed from the viewpoint of both original data provider and application servicer using the data. In providing data as open data, this anonymization process is indispensable to maximize the use of private data as rich services.

- **Contents of data**

Services or applications of smart sustainable cities mainly focuses on contents of data. The data can be separated into two parts: header as an index or tags from the viewpoint of data management and contents. Contents are the main part of data. For the entity providing an application and its user, the type of information included is considered important. The valuable application of the data strongly depends on this information.

- **Ownership of data**

For the application service provider of the data and its user, the data has to be reliable and used to address pertinent concerns. Data providers have to give the name of the organization in order to add value to the data. In short, the way to authorize the owner of the data is another issue for data services in a smart sustainable city.

- **Generation date/time and expiration of data**

For the application servicer provider of the data and its user, the date and time for when the data was generated is valuable information to determine the relevance and freshness of the data. In some cases, data analysis in its historical trend or changes is achieved. The date when the data was generated is fundamental information for this analysis. In addition to the information, the expiration date and time is required. Traffic information and market information can be the examples of data that the expiration date and time is indispensable.

- **Update of the contents**

Some data of smart sustainable city requires continuous updating. Instead of static information, historical information requires to be updated to keep the data fresh. The frequency or interval of this update may influence evaluability of the data.

- **Anonymizer of the data**

From the application service provider of the data, and its user, the information regarding who or which organization anonymized the data is required to know whether the data is trustworthy and can be used. An authorized anonymization servicer provider should anonymize the data for maximizing the value of the anonymized data. Namely, the way to authorize the anonymization servicer is another concerning in data services in smart sustainable cities.

- **Anonymized date/time of data**

The information of anonymized date/time may not be directly concerned with the applications. However, it is needed from the viewpoint of traceability of data processing. When some privacy pirating attacks occurs, the information becomes a significant source of its detection and prevention.

### ▪ Anonymized method and level

In data anonymization, the method of anonymization and the level of the anonymization is matter of concern to the data application providers and users. The level of anonymization could impact on the information loss of data<sup>17</sup>. The information loss is an index of similarity with the original plain data. The information could be changed or lost in anonymizing data, and information loss gives the level of the change or loss. The existing anonymization method and its level will be described in section 8.

## 2.2 The objective of open data

In the open government point of view, the objective is to build more transparent, participatory and collaborative administration. However, in SSC, three other objectives should also be emphasized, one is to inspire innovation in the data industry and to create new businesses and building industry chain. The second is to discover deeply hidden relationships from multisource data. The third is to facilitate the citizen living with innovative applications of open data. Open data reduces barrier and cost for entrepreneurs and a new industrial chain of data consumption is built by combining the efforts of data creators, data collectors, data exchangers and data consumers in more efficient way. Innovation takes place in the new industry driven by open data and original applications are created that change the living. Open data and the open data driven-industry creates tremendous economic value. A report by Lateral Economics show that open data will lead to a gross domestic product (GDP) increase of 13 trillion USD for G20 countries between 2015-2020<sup>18</sup>. The McKinsey Global Institute (MGI) predict that open data will increase direct and indirect benefits up to 3-5 trillion USD per year<sup>19</sup> in seven areas including education, health, and transportation. Open Gov Data in European Union (EU) would increase business activity by up to €40 billion/year

Open data can help to make better decisions in one's life. It may also enable individuals to be more active in society. A woman in Denmark built findtoilet.dk, which showed all the Danish public toilets, so that people she knew with bladder problems could now trust themselves to go out more. In the Netherlands a service, vervuilingsalarm.nl, is available which warns you with a message if the air-quality in your vicinity is going to reach a self-defined threshold tomorrow. In New York, one may easily find out where to walk one's dog, as well as find other people who use the same parks. Services like 'mapumental' in the UK and 'mapnificent' in Germany allow you to find places to live, taking into account the duration of the individual's commute to work, housing prices, and attractiveness of the residential compound. GoodGuide<sup>20</sup> [4-4] take advantages of open data provides ratings for over 210,000 products. WeatherBill, the climate corporation based in San Francisco, use open data help farmers around the world adapt to climate change and increase their crop yields(see also Section 8.1). All the aforementioned examples use open data. The NYU's GovLab launches Open Data 500<sup>21</sup>, which is first comprehensive study of U.S. companies including examples of 500 companies that use open government data to generate new business and develop new products and services.

---

<sup>17</sup> Yuichi Nakamura, Kanae Matsui and Hiroaki Nishi, *Anonymization Infrastructure for Secondary Use of Data*, ICOMP'14 - The 2014 International Conference on Internet Computing and Big Data, 2014.

<sup>18</sup> Please see: [http://opendatachina.com/the-business-case-for-open-data/\(2014\)](http://opendatachina.com/the-business-case-for-open-data/(2014)).

<sup>19</sup> Joel Gurin, *Open Data Now: The Secret to Hot Startups, Smart Investing, Savvy Marketing, and Fast Innovation*, McGraw-Hill Professional.

<sup>20</sup> Good guide, [www.goodguide.com](http://www.goodguide.com) (2014).

<sup>21</sup> Open Data 500, [www.opendata500.com](http://www.opendata500.com) (2014).

## 2.3 Relationship between open data and smart sustainable cities

Smart sustainable cities are innovative efficient, green, safe, and livable place for citizens. Besides the importance of ICT infrastructure and newly emerging innovative technologies, typically including Internet of Things (IoT), cloud computing and so on, soft skills including multi-source information integration and coordination, real-time response is even more critical. In the traditional cities, before the informative age, information and data are dispersive and not open to the public. Even where the information belongs to the same owner like government, when they are collected by different agencies there could be problems in coordination and contributing to real-time response. In SSC, smart application based on open data enable car drivers find the optimal way to avoid traffic jams. City planning with open data in SSC is also an important direction. Cities, especially the metropolis, are divided in regions with different functions. Central business district (CBD) is located in the center of cities surrounded by residential living areas. In some cities, sub-centers of cities emerge to ease the population and traffic pressure in the center cities. Open data from operation business companies can help to understand the population density and dynamic behaviors in the cities, which can assist city management planning for new area development and district function positioning.

## 3 The framework of open data

---

### 3.1 The principles of overall design

Overall design of open data framework follows the following basic principles:

- **Openness**

Openness is a necessary process for system interconnection and data interaction; that is an important prerequisite to improve the maintenance of the system. From many aspects, openness can be reflected from the design of system architecture, database systems, operating systems, network, etc. It is convenient to adopt modular framework for a third party supplying a cross platform development tool. Also it is a continuous process to improve API and services relying on the feedback of the public and government departments.

- **Extensibility**

One important aspect of designing a framework is making sure the extensibility of the framework has been carefully considered. There is no dispute that data volumes are growing exponentially. Huge amounts of data are generated every hour of every day, and this data comes from an ever-increasing variety of sources. This requires system design to be considered from two aspects: one is high scalability of hardware; the other is component-based design of software.

- **Accessibility**

Accessibility is the degree to which a product, device, service, or the environment is available to as many people as possible. Accessibility can be viewed as the "ability to access" and benefit from some system or entity. The design objectives of open data are to strengthen the accessibility, utilization and availability of data. In data publishing and permission management, it is effective to ensure that published data can meet the needs of users, and this requires it based on the maximum degree of data sharing. On the other hand, providing high-value data sets released, without involving privacy, confidentiality, safety issues, should be based on the needs of each government department and the public. In data presentation, the public can easily get what they need through open data portal.

- **Simplicity**

There is no requirement that every dataset must be made open right now. Starting out by opening up just one dataset, or even one part of a large dataset, is fine – of course, the more datasets one can open up the better. Remember, moving as rapidly as possible is good because it means one can build momentum and learn from experience – innovation is as much about failure as success and not every dataset will be useful.

- **Maintainability**

Maintainability involves a system of continuous improvement – learning from the past in order to improve the ability to maintain systems, or improve reliability of systems based on maintenance experience. In other words, the maintainability of the system expressed as the probability that a system will be retained in or restored to a specified condition within a given period or expressed as the actual operating costs of the system. The availability of the system can be reflected from two aspects: hardware and software. Hardware equipment should be convenient for installation and upgrade; it should also have sufficient spare parts. Software should provide flexible and user-friendly admin interface for operators.

- **Security**

Security provides "a form of protection where a separation is created between the assets and the threat." These separations are generically called "controls," and sometimes include changes to the asset or mitigate the threat. Generally, it is useful to ensure absolute security through permissions setting, security certifications, anonymization technique and other means.

- **Advancement**

Advancement is responsible for maintaining the data in advance client/server(C/S), and relations database. This responsibility involves processing all data and keeping the data in database current. The system will use object-oriented design; use the web access technology in user interface design and then fully guarantee the requirements of application systems design and development.

## 3.2 The framework of overall design

The framework of open data is presented in the following Figure 1. The top layer consists of applications of data products to meet public need. The second layer is a one-shop portal providing services including data catalog, data services, app services, developer center, service center and map service. The third layer, which is the technology layer, consists of anonymization technique, meta data management, linked data technique, data visualization and social network technique. The fourth layer is open data management, with user management, quality management, security management and operation management. The original data comes from government, social groups, enterprise, and individuals. On the two sides of the framework, open data regularities and open data security system protect the security and privacy of data.



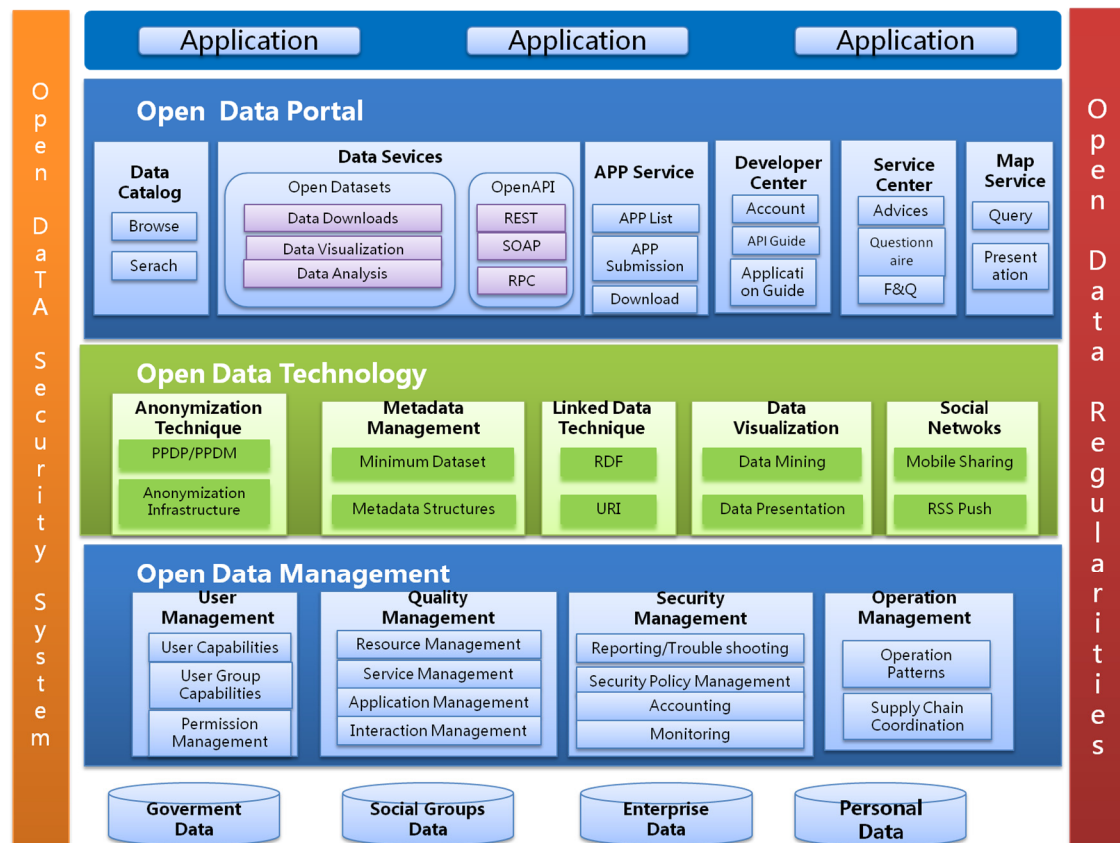


Figure 1 – The Framework of Open Data

The open data portal is the key part of open data which meets several goals:

- Offer a "one-stop-shop" experience to data consumers, saving the trouble of collecting data from various portals, authorities or offices with different controls and settings;
- Make it as easy as possible for government data stewards to make their datasets available for public consumption.

The open data portal provide four type of services, the data catalog for data sets browsing and searching, the open data service including data downloading, visualization and analysis as well as API access, the APP services and service center. Application developers access data through APIs like representational state transfer (REST), simple object access protocol (SOAP) or remote procedure call protocol (RPC). These developers create new web/mobile applications to facilitate service consumer and constitute and important part of the data industrial chain.

The use of data sets and App services can help users to obtain top recommended resources and applications that they may have a great of interest. Also, users can click on "More" buttons to the demo page.

### (1) Open data portal

#### Data catalog

- Provide some levels of presentation, including unified list and isolated resource;
- Provide some levels of the classification system;
- Provide keyword and resource type to search;

- Provide topic, department, location, label or map to search.

#### *Data services*

- Provide a variety of machine-readable data format, including XML, RSS, CSV/Text, KML/KMZ (Geospatial Data Format), ESRI Shapefile (Geospatial Data Format);
- Provide the statistics of data download and data query;
- Provide the name, source institution, links, format, size, release data, etc.;
- Provide data related maps and visual display.

#### *APP service*

- Provide some types of applications, including website and mobile app;
- APP List: include name, description, operating platform, download links, developer information and so on;
- APP Submission: include name, label, classification, description, version, charge mode, updated time, size, operating platform, download links and so on;
- APP Download: include name, label, classification, version, charge mode, rating, guidelines, and so on.

#### *Developer center*

- Provide "My Applications" account;
- Provide related learning, exchanging, authorization, development and management of application;
- Provide different types of API for registered users to download data or to call data: API download, API introduction, guide book, sample code, and other common problems.

#### *Service center*

- Provide advices and Q&A through communication and interaction, include recommendations for improvement, score and rank data resources and so on;
- Intercommunion and Interaction among users, including data resource evaluation;
- Intercommunion and Interaction between users and portal: include e-voting, online questionnaires, online communication;
- Provide personalized participation mechanisms through social network site (SNS) technology;
- Provide customized data based on a hot topic and user interest.

#### *Map service*

- Provide data query services through binding data resources and geographic information, and then directly present on the map.

## **(2) Open data technology**

The open data portal is supported by four main technologies, the metadata management, the linked data technique, the data visualization and social networks.

#### Metadata Management

- Provide minimum data set;
- Provide metadata structures.

#### Linked Data Technique

- The first step is ontology design, including vocabulary selection and vocabulary design;
- The second step is RDF structuration, including the type of data, data preparation, data storage, data publication and the type of publication;
- The third step is relationship establishment, including relationship links, links identification, vocabulary links and the type of relationship;
- The last step is data fusion, including crawling pattern, on-the-fly dereferencing pattern, query federation pattern and fusion mode.

#### Data Visualization

- Data mining;
- Data presentation.

#### Social Networks

- Mobile Sharing;
- RSS push technique.

#### Anonymization Technique

- Suppression;
- Pseudonymization (hash function);
- Generalization
  - Top/bottom coding
  - K-anonymity
  - l-diversity
  - T-closeness
  - Non-intrusive Load Monitoring (NILM)
  - Homomorphic encryption
  - Randomization (Pk-anonymization)
  - Perturbation
    - micro-aggregation
    - noise injection
    - data swapping
    - synthetic microdata.

### **(3) Open data management**

#### **(a) User management**

- Provide user Management capabilities, user group management capabilities, and role-based (RBAC) permission management capabilities;
- User management capabilities include query, new-built, account management, and so on;
- User group management capabilities include query, new-built, permission modification, and so on;
- Permission lists include function module uses-permission, data access permission, and so on.

**(b) Quality management**

- Provide resource management capabilities, service management capabilities, application management capabilities and interaction management capabilities;
- Resource management capabilities include resource exchange, resource synchronization, resource auditing, resource publishing, resource status monitor, and so on;
- Service management capabilities provide API interfaces for data resources so that developers can easily implement or attempt to access an external resource without download to local host. Under the premise of data update, it is possible to obtain the latest data resources;
- Application management capabilities mainly used to audit applications provided by developer, in addition to uniformly manage the on-line application of unified management, to monitor the entire application environment, and to timely investigate the abnormal operation of APP application;
- Interaction management capabilities mainly used to review applications of users, to respond to comments, to create questionnaires, to investigate statistical data, to update common questions and so on.

**(c) Operation management**

- Provide several operation patterns: include independent operation, cooperative operation, outsourcing operation, and so on;
- Provide supply chain coordination as well data flows both in and between links in the chain, which include government, enterprise, social groups and individuals.

**(d) Security management**

- Anonymization technology is a part of security management in some studies;
- Anonymization technology is used for protecting original data. The main purpose of anonymization technology is to open data for everyone. The main point of anonymization for management is the level of anonymization. Although a strong anonymization makes it difficult to identify, it becomes difficult to use the data for services because it contains less information, vice versa. It is required to select best anonymization levels according to the target services.

**(4) Open data security system**

- Security system provides operation and system level security protection and privacy preservation in the open data system.

**(5) Open data regularities**

- Regularities provide top-down institution level security protection and privacy preservation in the open data system.

## 4 Open data handling in SSC

---

### 4.1 Barriers and constraints in open data

Data management is to do with managing the information life cycle which should include policies and processes for acquiring, validating, storing, protecting and processing data. The data infrastructure of smart sustainable city has to define the information and its expression as a clear format considering the interoperability with other standards. It also has to support the way to

express the information as application programmable interface (API) for application programmers as a programming standard. As associated with these information, the information of management status is indispensable, such as duplication or backup layer of the data, storage of the data (datacenter or local server), latency and throughput to get the information, regulations in user, group, throughput, date or time, amount of fetching, count of accessing, ID or address in network and application layer, and accounting. Moreover, if API, security software/application, and other middlewares such as database, machine learning is used, the name and version of this software are required. This management can be the basement of privacy preserving. If the data management is not well organized, the following problems and risks will appear.

- **Falsifying data or illegal overwriting/deletion/wiping of data**

If appropriate security is not given, falsifying attacks damage data by illegal overwriting, deletion, and wiping.

- **Slow or imperfect recovery from attacks**

Data provider should provide the information on its data protection and security level before making it available. In some cases, they will provide additional backups or options of security to meet their requirements. If it is not considered, slow recovery or imperfect data recovery may occur more serious than they expected.

- **Privacy invading**

Those who provide privacy data require a clear expression of the data, such as management status, number or type of applications, and number or type of users or the providing data.

- **Increasing the cost of data guarantee services and insurance services**

Data guarantee services and insurance services providers require to know the status of data management of smart sustainable city. If the status is not clear or missing, the cost of providing services will be increased. From the application viewpoints, these problems and risks may bring serious compromises by paralyzing infrastructures in smart sustainable city.

As described above, the infrastructure of SSC has to give a way to express the status of data management, the format of data contents, management information, authorization, and certification.

On that basis, the way to distribute data and to keep consistency of distributed data is required as a part of data infrastructure of SSC. According to the data distribution, hierarchical multi-grain network architecture for smart community is proposed by IEEE Standards Association<sup>22</sup>. Every service on a smart sustainable city should select the layer of the hierarchical network where a service is provided and processed. The consistency of the data is also managed by a distributed database in a hierarchical network architecture. This means discussion of locality and latency is the key to data consistency in the SSC. CAP theorem in theoretical computer science states consistency, availability, and partition tolerance cannot be guaranteed simultaneously, and one of them has to be omitted in designing systems. A model, which guarantees consistency and availability, supports hard real-time services with data consistency. In applications of SSC, the model is applicable to traffic signal control and power grid management of power stabilization service in a local area. However, single point of failure lurks in a system using the model because it does not guarantee partition-tolerance. A model, which guarantees availability and partition-tolerance, supports wide-area low-latency services such as naming rule service, sensor node management, and location services. In this model, consistency process becomes slower

---

<sup>22</sup> Hiroaki Nishi, Koichi Inoue, et al.; *IEEE SMART GRID VISION FOR VEHICULAR TECHNOLOGY: 2030 AND BEYOND*; IEEE Standards Association, pp. 41-42, Jan., 2014.

than other systems. A model, which guarantees consistency and partition-tolerance, supports wide-area low-latency services such as trading, data broker service, and timing-critical data mining service. In this model, failure may degrade the functionality of separated subsystems. Some application will require the combination systems of two or more models.

These modes can be used at the same time. For example, a system locally guarantees consistency and availability and widely guarantees availability and partition-tolerance. Each service and application of SSC defines the marginal type of different models. Moreover, the service and application defines the service providing points in the hierarchical network structure, namely where the service and application are provided. The information infrastructure of SSC should have enough flexibility to manage all these model combinations and service providing points.

## 4.2 Security protection and privacy preservation of open data

In open data issue, security protection and privacy preservation are crucial. In this globalized information society, it is impossible to attain security only by one enterprise of government because its complexity and meshed connections. To address this situation, new information infrastructure, and data processing rules are required. In some cases, the meaning of security protection in open data is equal to that of general security protection. However, open data is open to everyone, and technically it should be allowed to be accessed from anyone and anywhere. This means security issue is not as serious as generally discussed security. However, the access to the open data is regulated because of its license or its charge of usage. Accounting, usageconfirmation and illegal usage protection, could be the main issue of the security in using open data. Another security issue is original and unfalsified authenticity. This authenticity will be given by the technique of digital watermark, digital fingerprint with hash codes or the use of certificate authority system. Digital watermark and digital fingerprint are well-used technology to prevent falsifying. To use them, a common rule as standards is required to achieve an environment that everyone can check the original and unfalsified status of the data in the same way. For the use of certificate authority system, it requires a special organization like a certificate authority (CA) of public key infrastructure (PKI). The difference between the CA of open data and CA of PKI is that CA of open data focuses the point of data integrity in addition to the functions of CA of PKI, such as preventing spoofing, falsification, eavesdropping, and degeneration. CA of open data has to certify the data integrity whenever it is requested, and this means CA of open data has to manage all published open data and its fingerprints to verify the integrity.

According to the preservation of privacy, Privacy-Preserving Data Mining (PPDM)<sup>2324</sup> and Privacy-Preserving Data Publishing (PPDP)<sup>2526</sup> are well-known techniques. These techniques can mine or publish the data without personally identifiable information, thereby protecting the privacy. Anonymization is a practical technology that supports privacy protection. Anonymization technology can adjust to different privacy protection levels, thus providing flexible privacy protection. A considerable variety of studies on this technique have been performed owing to its high versatility. It is one of the most preeminent privacy protection technologies in current use.

---

<sup>23</sup> Rakesh Agrawal; Ramakrishnan Srikant; *Privacy-preserving data mining*; SIG-MOD, Vol. 29, pp. 439-450, 2000.

<sup>24</sup> Yehuda Lindell; Benny Pinkas; *“Privacy Preserving Data Mining*; Journal of Cryptology, Vol. 15, pp. 177-206, 2002.

<sup>25</sup> Bee-Chung Chen; Daniel Kifer; Kristen LeFevre; Ashwin Machanavajjhala; *Privacy-Preserving Data Publishing*; Foundations and Trends in Databases, Vol. 2, No. 1-2, pp. 1-167, 2009.

<sup>26</sup> Benjamin C. M. Fung; Ke Wang; Rui Chen; Philip S. Yu; *Privacy-preserving data publishing: A survey of recent developments*; ACM Computing Surveys (CSUR), Vol. 42, No. 4, 2010.



Generalization and deletion of the data are necessary to prevent privacy infringements. However, they reduce the value of the data. As a result, there is a trade-off relationship between privacy protection and the utilization of the data.

Although techniques such as PPDM and PPDP have been investigated in numerous studies, a method of securely publishing the data to enable secondary use has not been definitively established. This secondary use is the essential way of data to make interaction between different infrastructures. As shown in IEEE SMART GRID VISION FOR VEHICULAR TECHNOLOGY: 2030 AND BEYOND, the future infrastructure exchanges data to use for inter-infrastructure smart services. PPDM and PPDP are an indispensable technique to maximize the distribution range of data. The anonymization method is the key of PPDM and PPDP. Anonymization enables the publication of private data by changing public data by omitting sensitive information.

However, from the viewpoint of security of anonymization, there is a possibility of privacy leak. After calculating and publishing anonymized data from a data source, another anonymized data set, calculated and published from the same source may cause a privacy information leak if an unauthorized person can access both sets of anonymized data. When calculating and publishing anonymized data, it is necessary to consider all of the previously published data from the same source. This leak will become larger when the data transaction in smart sustainable city becomes more active. To provide a way to protect the leak, new architecture of data management is required.

Considering these issues, it is crucial to establish a clear suggestion of technological guidance, an infrastructure, and a technical standard of protocols for the secondary use of data. The development of the protocol and infrastructure is especially important for the data infrastructure of smart sustainable city. It will facilitate collaboration between organizations that produce the data and the companies that require the data for secondary use, and thus increase their data publishing activity. It will develop new service and market for secondary uses of data in conjunction with advanced services such as market research, estimation of a route of infection, and traffic pattern analysis. Moreover, it will reduce the utilization costs for both providers and consumers of secondary use data, owing to the unification of data processing procedures.

### 4.3 Policy and regulation

The Open Data policies are driven by a push for economic growth and job creation. President Obama made this clear when he announced his administration's new Open Data Policy in May 2013. This policy, which will make unprecedented amounts of federal data available in highly usable forms, has a business agenda first and foremost. Significantly, the President didn't make his announcement at a Washington press conference or in the Rose Garden but on a visit to a technology center in Austin, Texas. There he promised that governmental open data is going to help launch new businesses of all kinds in ways "that we haven't even imagined yet".

The Open Data Policy includes a detailed description of the criteria for government data to be released as Open Data, drawing on work done by the Open Knowledge Foundation in the United Kingdom, the Washington-based Sunlight Foundation, and others.

Technology of security protection and privacy preservation is the one wheel of a vehicle and the other wheel is political support by government. Open data and privacy issue conflict with each other. To publish open data, private information has to be removed from the open data. Meanwhile, the value of open data will be degraded when private information is removed significantly. Although this trade-off problem can be eased by using technology, it cannot be perfectly solved only by using technology.

Political support is indispensable to give a guideline and guarantee the safe transaction of open data, namely publish and use of open data in smart sustainable city. Here, another trade-off comes. It is natural for data provider as the source of open data to minimize the leak of the information for preserving privacy. Political support gives the clear burden for fulfilling or negotiating both requirements of data provider and data services. This support should be varied according to the services and applications.

## 5 Technologies related to open data in SSC

---

It is found that open data is comprised of a great diversity of research streams and related topics in SSC. However, most connected and influencing open data are the following technology streams.

### 5.1 Metadata management

Metadata is "data about data", of any sort in any media<sup>27</sup>. In other words, metadata is data that describes other data, which facilitates the understanding, usage, and management of data, both by human and computers. Metadata summarizes basic information about data, which can make finding and working with particular instances of data easier<sup>28</sup>. This commonly defines the structure or schema of the primary data. International standards apply to metadata. Much work is being accomplished in the national and international standards communities, especially ANSI (American National Standards Institute) and ISO (International Organization for Standardization) to reach consensus on standardizing metadata<sup>29</sup>. The core standard is ISO/IEC 11179-1:2004 and subsequent standards (see ISO/IEC 11179). All published registrations according to this standard cover just the definition of metadata and do not serve the structuring of metadata storage or retrieval neither any administrative standardization. It is important to note that this standard refers to metadata as the data about containers of the data and not to metadata as the data about the data contents. An important reason for creating descriptive metadata is to facilitate discovery of relevant information. In addition to resource discovery, metadata can help to organize electronic resources, facilitate interoperability and legacy resource integration, to provide digital identification, and to support archiving and preservation. According to NISO's definitions, there are three main types of metadata: descriptive metadata, structural metadata and administrative metadata<sup>30</sup>. Descriptive metadata describes a resource for purposes such as discovery and identification. It can include elements such as title, abstract, author, and keywords. There are many kinds of examples of descriptive metadata, such as CDWA (Categories for the Description of Works of Art), VRA (Visual Resources Association), DC (Dublin Core), FGDC (Content Standard for Digital Geospatial Metadata, for Federal Geospatial Data Committee), GILS (Government Information Locator Service), EAD (Encoded Archival Description), TEI (Text Encoding Initiative) and so on. Structural metadata indicates how compound objects are put together, for example, how pages are ordered to form chapters. Administrative metadata provides information to help manage a resource, such as when and how it was created, file type and other technical information, and who can access it.

---

<sup>27</sup> Please see: <http://en.factolex.com/metadata>.

<sup>28</sup> Mize, J.; Habermann, R.T. *Automating metadata for dynamic datasets*. OCEANS 2010. 2010, Page(s): 1-6.

<sup>29</sup> Please see: <http://www.niso.org/publications/press/UnderstandingMetadata.pdf>.

<sup>30</sup> NISO Press, National Information Standards Organization. *Understanding Metadata*.

**Table 1 – Comparison and analysis of common metadata standards**

	Applicable Type	User	Purpose
CDWA	Works of art, architecture, other material culture, groups and collections of works, and related images	Art historians, art information professionals, and information providers	Provide art categorization, make information of diverse systems both more compatible and more accessible
VRA	Works of visual culture as well as the images	Art collection organization	Description of works of visual culture as well as the images
DC	Online resources	Anyone, including experts, academics, students and library staff	Resource discovery
FGDC	Digital geospatial data	Government, research institute, and company	Share of geographic data, maps, and online services through an online portal
GILS	Federal information resources	Government	Identify, locate, and describe publicly available Federal information resources, including electronic information resources
EAD	Archival and manuscript collections at Harvard	Archives and manuscripts libraries	Materials, including letters, diaries, photographs, drawings, printed material, and objects
TEI	Electronic text	Libraries, museums, publishers, and individual scholars to present texts for online research, teaching, and preservation	A set of guidelines that specify encoding methods for machine-readable texts, chiefly in the humanities, social sciences, and linguistics

Within open data initiatives/communities, metadata is used to support the description of data sets (including data services), as well as documents and applications. Only if metadata structure and meaning are sufficiently uniform or self-explanatory, a central portal can be realized, to consolidate various data offers and the contents of existing external metadata catalogs. The implementation of consistent metadata in SSC is often driven by public decision-makers, data providers, developers and other open data initiatives, or application requirements. Metadata can be the foundation of resource description that can facilitate a shared understanding across business and technical domains. Metadata focuses on the essentials along with great flexibility without wasting time to process and understand the described data. For that reason, making metadata machine readable greatly increases its utility, but requires more detailed open standardization.

## 5.2 Linked data

Linked data primarily describes the result of consistently applying semantic web principles and technologies when publishing structured data that allows metadata to be connected and enriched, so that different representations of the same content can be found, and links made between related resources. It builds upon standard web technologies such as HTTP, RDF and URIs, but rather than using them to serve web pages for human readers, which extends them to share information in a

way that can be read automatically by computers<sup>31</sup>. This enables data from different sources to be connected and queried. The exponential growth of subject-predicate-object expressions creating links between formerly disparate resources leads to what has been called the Linked Data cloud. Relentlessly, public and private organizations as well as individuals contribute their data following semantic web standards<sup>32</sup>. In 2006, Tim Berners Lee stipulated that interlinking all this data makes it more useful if 5 simple principles are followed: available, machine-readable, non-proprietary data formats, RDF data format and interlinked to other data by pointing at it<sup>33</sup>. Besides the large, global vision of linked data, its use in an organization to expose its public information, or even to manage internal data, brings new possibilities that traditional data management models have been notoriously bad at handling: It provides a model for naturally accessible and integrated data. In addition, the graph model it uses offers a level of flexibility that makes it possible to extend and enrich linked data incrementally, without having to reconsider the entire system: there is no system, only individual contributions.

As SSC are a "system of systems", different systems give vast amount of information<sup>34</sup>. By using model smart city technologies, data amount increase more and more rapidly. This makes it possible to do many things that previously could not be done: spot business trends, prevent diseases, combat crime and so on. Managed well, the data can be used to unlock new sources of economic value, provide fresh insights into science and hold governments to account. However, the traditional data processing approaches cannot process such a vast amount of information. Big data is developed to deal this issue and make the city smarter than before. Linked data makes the world wide web into a global database called the web of data. Developers can query linked data from multiple sources at once and combine it on the fly, something difficult or impossible to do with traditional data management technologies<sup>35</sup>. Many individuals and organizations collect a broad range of different types of data in order to perform their tasks. The government is particularly significant in this respect, both because of the quantity and centrality of the data it collects, but also because most of that government data is public data by law, and, therefore, could be made open and made available for others to use. Linked data plays an important role in the construction and operation of the smart cities. When the smart city is constructed, open data can provide a large amount of data to assist the city planners and constructors. The citizens and city managers can make right decisions for city lives and managements.

Defining standard data layers and tools implemented for open data portal can provide semantic agreement between heterogeneous data sources. These sources are mainly websites of different institutions and agencies, which offer data online in unstructured or semi-structured formats such as text documents, excel files or XML files. There are very few sources that can provide data structured in entity-relationship model. The importance of standard data layers to minimize the conflict of data generated by several open data portals to publish their data using different models. Standard data layers for open data portal are divided into four layers as shown in Figure 2.

---

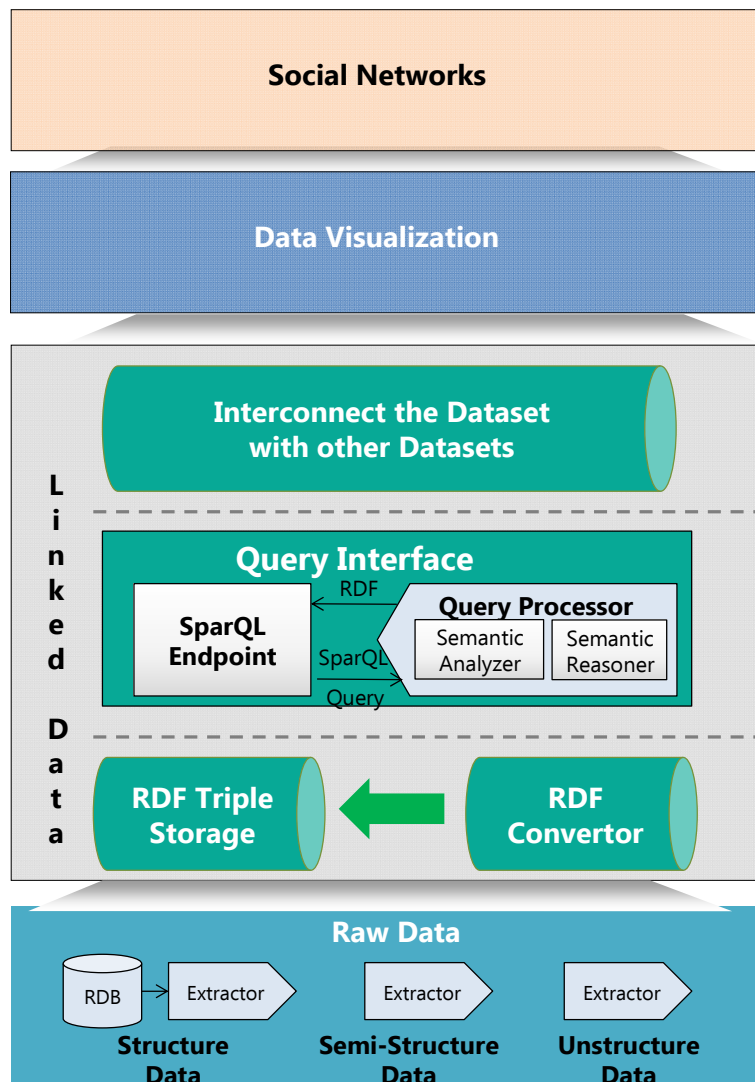
<sup>31</sup> T.; Bizer, C.; Linked Data: Evolving the Web into a Global Data Space Heath. 2011.

<sup>32</sup> Allen, B.P.; Tennis, J.T.; *Building metadata-based navigation using semantic Web standards: the Dublin Core 2003*; Conference Proceedings, 2004. Proceedings of the 2004 Joint ACM/IEEE Conference on. 200

<sup>33</sup> Please see: <http://linkeddata.org/faq>.

<sup>34</sup> Turchi, S.; Paganelli, F.; Bianchi, L.; Giuli, D. *A lightweight linked data implementation for modeling the Web of Things*. Pervasive Computing and Communications Workshops (PERCOM Workshops), 2014 IEEE International Conference on 2014, Page(s): 123-128.

<sup>35</sup> David W., Marsha Z. and Luke R. with Michael H.; *Linked Data: Structured Data on the Web*.



**Figure 2 – Overall Standard Data layers for Open Data Portal**

The first layer is raw data layer. According to Elmasru and Navathe and Kent, data can be further classified into three components: structured data, semi-structured data, and unstructured data. Structured data are those organized in according to a rigid and pre-defined criteria such as respecting various fields (or attributes) of data, delimiting the scope, domain (possible values) of data, data type, etc. This is the case, for example, with data involved in tables of relational databases (RDB) used by most institutions. The structured data extractor is responsible for data extraction of data stored on the RDB. An important aspect of data publication on the traditional Web is related to the loss of structure while transforming this data from RDB to open data portals. These data are converted into current web formats, making them unstructured. Semi-structured data are given in a way one cannot always predict all aspects of a given piece of data. Some of its general attributes can be known and required in advance, others added later depending on circumstances. References are an example of semi-structured dataset, containing fairly similar items. The semi-structured data extractor is responsible for data extraction of semi-structured data on the open data portals. Unstructured data are those for which no scheme is specified, containing only the content and a means of presenting it. An example is the text on a HTML page. The unstructured data extractor is responsible for data extraction of unstructured data on the open data portals<sup>36</sup>.

<sup>36</sup> Please see: <http://linkeddata.org/faq>



The second layer is linked data layer. After gathering the raw data independently from the different sources, is to perform the converting from structured, unstructured and semi-structured data to semantic data. This converting is made by means of an ontology (e.g., vocabularies, taxonomies) that describes these data. To perform this converting, our approach makes a priori converting based on standards. This process is made by converting from the OWL ontology to RDF triples. We observed existing approaches to perform converting only from structured data to RDF. The RDF datasets are stored in a CKAN repository, which is made public and can be accessed via the CKAN web interface and CKAN API<sup>37</sup>. From a technical perspective, the objective is to use common standards and techniques to extend the web by publishing data as RDF, creating well-formatted RDF links between the data items, and performing search on the data via standardized languages such as SPARQL query language for RDF, performing search on the data via standardized languages such as SPARQL query language for RDF. Query interface, which enables the user community as well as the source institutions that offer these statistical data to pose queries upon it. This component consists of an online graphical interface as well as a SPARQL endpoint. The results of a query may be displayed as structured excel and RDF files to the users. Query interface layer is the sub-layer providing the open data, consisting of two components: SparQL endpoint and Query processor. SparQL endpoint is the query interface of submission and retrieval results in open dataset submitted by Interconnect the dataset with other datasets. Query processor analyze the SparQL queries to verify which artifacts stored in the semantic database will be used. There are two components: Query analyzer and Semantic reasoner. Query analyzer analyzes SparQL query features to verification of the necessary elements to be used to return query results. Moreover, to improve the response time of a query uses the indices and metadata. Semantic reasoner is responsible for generating knowledge derived from inference about the immediate knowledge. One consideration is that this mechanism degrades the performance of a query. So this mechanism will be activated dynamically according to the complexity of the query submitted. Interconnect the dataset with other datasets is the sub-layer that allows data fusion of semantic data<sup>38</sup>. The open data API is a RESTful, service-oriented platform that allows developers to easily access datasets and create independent services through these calls. REST uses the HTTP protocol and, as such, requests use the common URL format. The API provides simple methods that developers can use to tap into the functionality and rich datasets, and gather information, in JSON or XML format, related to different indicators and topics<sup>39</sup>.

A visualization service is delivered to the site and could include analytics, graphics, charting, and other ways of using the data. The enhanced visualization is built on top of published APIs in collaboration with third party open source applications.

### 5.3 Data visualization

Data visualization is a modern branch of descriptive statistics meant to allow people to both understand and communicate data clearly and efficiently via the data graphics selected, such as tables, maps, charts and so on<sup>40</sup>. In the context of SSC for visualization, part of the data is stored in a digital file, typically in either text or binary form. Of course, potentially every piece of digital ephemera may be considered "data"—not just text, but bits and bytes representing images, audio,

---

<sup>37</sup> Franck M., Johan M. and Catherine F.; A survey of RDB to RDF translation approaches and tools.

<sup>38</sup> Please see: <http://lists.w3.org/Archives/Public/semantic-web/2011Oct/0041.html>.

<sup>39</sup> Richardson L, Mike A, RESTful web APIs. 2013

<sup>40</sup> Please see: <http://www.math.yorku.ca/SCS/Gallery/milestone/milestone.pdf>



video, databases, streams, models, archives, and anything else. Nowadays, excess amounts of open data are overwhelming; raw data becomes useful only when we apply methods of deriving insight from it. Fortunately, we humans are intensely visual creatures. Only trained professionals can detect patterns among rows of numbers, but even young children can interpret bar charts, extracting meaning from those numbers' visual representations. For that reason, data visualization is a powerful exercise<sup>41</sup>. Visualizing data is the fastest way to communicate it to others. The definition of data visualization references its two objectives: understanding and communication<sup>42</sup>. This can also be referred to as exploratory and explanatory the visual representation of data respectively. This distinction is often overlooked, but it is extremely critical in the process of creating successful data visualization. If the motivation is to make sense of data, then the data visualization should be exploratory in nature. The process of visualization can help to see the world in a new way, revealing unexpected patterns and trends in the otherwise hidden data around us. At its best, data visualization is expert storytelling. However, if the analysis of the data is complete, then infographic should be used. More literally, visualization is a process of mapping complete data to visuals<sup>43</sup>. It is possible to craft rules that interpret data and express its values as visual properties. Without being conscious of one's data visualization motivations and goals, the process can be inefficient, misguided, or altogether unsuccessful.

**Table 2 – Open publishing of Ooof data visualization**

Revised Date	Production Name	Tag	Visualization Tools	Designer	First Time
29-Sep-14	World's religious numbers	World and religion	yEd	Ooof	2011-7-23
21-Feb-14	India's religious development process	India, religion, and process	yEd	Ooof	2011-7-23
21-Feb-14	Journey to the West figure relationships	Journey to the west and figure	Gephi	Ooof	2011-7-23
21-Feb-14	50 twitter's relationship Diagram	Twitter	Gephi	Ooof	2011-7-23
21-Feb-14	Pushing around 5000 years	History and 4000	BB FlashBack	Ooof	2011-7-23
21-Feb-14	107t twitter's relationship diagram	Twitter	Gephi	Ooof	2011-7-23
1-Feb-13	Wuxi training camp's NGO relationship	Wuxi and NGO	Gephi	Ooof	2012-4-23
1-Feb-13	Linfen's government budget information	Linfen, budget, and Government	Gephi	Ooof	2012-4-23
1-Feb-13	Relationship Visualization among linfen's 29 Weibo friends	Linfen, Weibo, and Realtionship	Gephi	Ooof	2012-4-23
1-Feb-13	Human emotion's spectrum	Emotion	Gephi	Ooof	2012-4-23

<sup>41</sup> Xiao Q., Yan W., Zhang H.; *Application of Visualization Technology in Spatial Data Mining*; Computing, Control and Industrial Engineering (CCIE), 2010 International Conference on. 2010, Page(s): 153-157.

<sup>42</sup> Accenture | Strategy. Understanding Data Visualization. 2013

<sup>43</sup> Please see: <http://www.accenture.com/SiteCollectionDocuments/PDF/Accenture-Tech-Labs-Data-Visualization-Full-Paper.pdf>.

Data visualization is increasingly becoming a popular way to portray and distribute complicated information in a consumable way to increase efficiency and work smarter<sup>44</sup>. By linking city's performance management systems to tools that provide instant access to current and historic records, more and more governments are allowing almost anyone to view and manipulate open data via vivid pie charts and line graphs. Users can even export raw numbers or high-impact graphics for use in meetings and communications materials. On one hand, the open platform is saving us hundreds of work hours by reducing the time that staff spends sorting through files of various data. On the other hand, as more citizens are using this technology we are starting to see many new inquiries come in from people interested in learning more about how smart city operates. By providing residents with the tools to visualize and work with open data to meet their individual needs, data visualization is not only increasing city management transparency and accountability but also enhancing the ability of city officials to be more responsive to citizens' needs. From other aspects, data always changes over time, only used static datasets barely reflect those little changes, the visual adjustments are made pretty with transitions, which can employ motion for perceptual benefit crosscutting all SSC domains.

## 5.4 Social networks

Social networks are typically defined as a social structure made up of a set of social entities (such as individuals or organizations) and a set of the dyadic ties between these entities<sup>45</sup>. In other words, social networks are based on a certain structure that allow people to both express their individuality and meet people with similar interests. The social network perspective provides a set of methods for analyzing the structure of whole social entities, as well as a variety of theories explaining the patterns observed in these structures. The study of these structures uses social network analysis to identify local and global patterns, locate influential entities, and examine network dynamics. Social networking services (or social network sites) are websites or web-based services that allow people to build online communities where they can connect and interact with other people who have similar interests, identical backgrounds, or real-life connections<sup>46</sup>. The key components of a social network service are the ability for people to create a profile about themselves, the ability for people to create a list of other people who have a shared connection or similar interests, and the ability to view the connections made by other people in the network. Most social network services are web-based and provide means for users to interact over the Internet, such as e-mail and instant messaging. Examples of popular social network services include: Facebook, Twitter, LinkedIn, Pinterest, GovLoop, MySpace, and Friendster. Related to social networks, media-sharing services (video, photo/image, audio) are web-based platforms that allow people the ability to view, discuss, upload, distribute, notify and store digital content in a social environment. The power of media-sharing services is that they provide people or organizations a platform to discuss and disseminate information using multimedia content. Examples of various media-sharing services include: photo/image (Flickr, Photobucket, Picasa, SmugMug), video (YouTube, Vimeo, Veoh). Photo/image provides a visual representation to help people to understand easily and communicate with other people.

---

<sup>44</sup> Please see: <http://www.emprata.com/what-we-do/data-visualization/>.

<sup>45</sup> Social Network: Stephen B.P, Mehra. A , Daniel J, Giuseppe. L . Network Analysis in the Social Sciences". Science 323. 2009.

<sup>46</sup> Irfan, R., Bickler, G., Khan, S.U., Kolodziej, J., Hongxiang Li, Dan Chen, Lizhe Wang, Hayat, K., Madani, S.A., Nazir, B., Khan, I.A., Ranjan, R; *Survey on social networking services*. Networks, IET. 2013, Page(s): 224-234.

Without social networks, the ability for user-generated content to propagate and penetrate the public sphere would be seriously hindered. Therefore, citizen journalism or citizen reporting is heavily tied to user generated content and media-sharing services. Many governments have seen social networks and media-sharing as ways to disseminate the same information to different individuals and social groups. For example, Cisco's infographic on the Internet of Things explains the connotation and also forecasts that by 2020, there would be 50 Billion 'things' connected to the Internet. These things are interconnection of objects ranging from PCs, mobile, TVs, cars, vending-machines, cameras, alarm clocks, to even cattle and many more. The visual displays how these connected things could make a difference to daily lives. Along with multiple social networks presence: a Facebook page, a YouTube channel and so on. Many different governments and government agencies are now taking similar approaches to incorporation of social networks approaches like Facebook into their data and communication activities to promote access to and usage of open data.

## 5.5 Anonymization technology

Known anonymization technologies are as listed:

- (1) Deletion of attributes
  - (1.1) Attributes suppression  
To remove sensitive identifiers for protecting identification of personality.
  - (1.2) Pseudonymization  
To replace sensitive identifiers or combinations of identifiers, such as name, date or birth to a code or number, etc. Hash function can be the candidate to calculate the code.
- (2) Change of attributes
  - (2.1) Generalization  
To replace an attribute to a generalized value or higher word in concepts. For example, 10-year steps, change cucumber to vegetables, etc. Rounding is a way of generalization.
  - (2.2) Top/bottom coding  
To put together small or large values into one attributes. For example, those who are older than 100 years is changed to ">100".
- (3) Perturbation
  - (3.1) Micro-aggregation  
After grouping the original data, each attribute of records in a same group is replaced by a representative value of the group.
  - (3.2) Noise injection  
To add random noise into numeric attributes probabilistically.
  - (3.3) Data swapping  
Stochastically swapping the values of the attribute between records.
  - (3.4) Synthetic microdata  
To create artificial synthetic data to be statistically similar to the original data.

- (4) Other techniques
  - (4.1) Suppression or records  
To delete records with a special attribute or value. For example, a record which has a value of more than 120 is deleted.
  - (4.2) Supression of cells  
To delete sensitive attributes such as the attributes which should not be used for analysis.
  - (4.3) Sampling  
To extract a value randomly from the entire original data at a constant rate or number.
- (5) Advanced anonymization methods
  - (5.1) k-anonymization, l-diversity, l-closeness  
These PPDP method is described in the section of Use Cases.
  - (5.2) Pk-anonymization  
A method of anonymization that guarantee the probability to point out a personal record is less than  $1/k$  in probability.
- (6) Application specific anonymization methods
  - (6.1) Battery-load hiding  
Battery-load hiding (BLH) techniques were proposed to ensure household privacy<sup>47,48</sup>. BLH hides or obscures real electric consumption by charging and discharging batteries, which are set with each household. This approach tries to keep electric power consumption data constant value and make it impossible to infer real usage of home appliances by NILM.
  - (6.2) Others  
The anonymization methods explained in section 11 belongs this category.

## 6 The management of open data in SSC

---

### 6.1 Executive institution management

Open data is a valuable resource and a strategic asset to the government, its partners, and the public. Due to the existence of institutional mechanisms there are more barriers between information systems, data showing disorderly scattered islands situation, the actual utilization of data is very low. Scattered data means that the data from various agencies and institutions unable to form an open source browser-based map that enable citizens and enterprise hardly to visualize open data from agencies, institutions and other people. Also, a thorough analysis helps agencies and institutions pinpoint needs, priorities, and existing capabilities for open data. Before the analysis begins, however,

---

<sup>47</sup> McLaughlin, S., McDaniel, P., & Aiello, W, *Protecting consumer privacy from electric load monitoring*; In Proceedings of the 18th ACM conference on Computer and communications security CCS '11 ,2011.

<sup>48</sup> Yang, L., Chen, X., Zhang, J., & Poor, H.; *Optimal Privacy-Preserving Energy Management for Smart Meters*, IEEE INFOCOM, 2014,Page(s): 513-521.

it is wise to establish executive departments and agencies for open data that we name it as Open Data and Manpower Bureau (ODMB) consisting of all important stakeholders for open data and data management processes. Many of the responsibilities of ODMB are the same, regardless of where the person falls within the organization. So the heads of ODMB is a mandated role, and individuals appointed are responsible for ensuring that data is handled and managed appropriately. This means making sure that data is properly protected and that their value to the organization is fully exploited. Memorandum establishes a framework to help institutionalize the principles of effective information management at each stage of the information's life cycle to promote interoperability and openness. Whether or not particular information can be made public, agencies can apply this framework to all information resources to promote efficiency and produce value.

## 6.2 User management

Broadly speaking, user management<sup>49</sup> encompasses the processes and technologies that allow an organization to more securely and efficiently.

- Add, create, and delete users from its systems;
- Provision all the applications and resources a user needs;
- Enable users to manage their own profiles using self-service techniques.

## 6.3 Quality management

- Provide resource management capabilities, service management capabilities, application management capabilities and interaction management capabilities;
- Resource management capabilities include resource exchange, resource synchronization, resource auditing, resource publishing, resource status monitor, and so on;
- Service management capabilities provide API interfaces for data resources so that developers can easily implement or attempt to access an external resource without download to the localhost. Under the premise of data update, it is possible to obtain the latest data resources;
- Application management capabilities mainly used to audit applications provided by developer, in addition to uniformly manage the on-line application of unified management, to monitor the entire application environment, and to timely investigate the abnormal operation of APP application;
- Interaction management capabilities mainly used to review applications for users, to respond to comments, to create questionnaires, to investigate statistical data, to update common questions and so on.

### (1) Data acquisition mechanism

Establishment of biodiversity data acquisition mechanisms of multi-side participation, division of labor, coordination of work and high effective operation, which is the effective method in the case of data comes from different sectors, areas, and geographies.

Vertical data Link, primarily consist of all levels of the data set, covering the areas of public safety, public services, transportation services, education technology, financial services, energy and environment, health and hygiene, culture, entertainment and other fields;

---

<sup>49</sup> Lichun Zhu, Kent, R.D., Aggarwal, A., Virantheni, P., Rahman, Q., Elamsy, T., Ejelike, O; *Construction of a Webportal and User Management Framework for Grid*. High Performance Computing Systems and Applications, 2007. HPCS 2007. 21st International Symposium on. 2007, Page(s): 14.

Horizontal data link, primarily by the way links can point to other open platforms, and then portals integrate applications and information and present them to the end users as one unified view.

Open data portal mainly collect and manage sources of data that is produced by various government departments, enterprises, social groups and individuals.

Government departments, enterprises, social groups should regularly publish their open-access data sets through open data portal, but these data sets should not appear before, or as non-downloaded format appeared on the network.

In order to make all government departments, enterprises, social groups are willing to and can add their data sets through open data portal, it should provide a variety of mechanisms to greatly ease publication process.

## **(2) Catalog system**

Through a comprehensive classification system of data, open data should provide integrated management features for data resources on the platform, and then according to different classification multiple formats of data resources should be compiled into the same level of catalog, such as (a) raw data catalog, (b) tools catalog, (c) geographic data catalog, and so on. Data resources can also be classified based on a different topic and different institutions. By two-level catalog system, the classification of data resources should be set up macroscopically and microscopically, not only make clear of data resources appearance, but also facilitate discovery and use of data resources. This can easily improve the quality of open data portal and promote high efficiency of data resources.

## **(3) Data availability management**

Establishing a strict review mechanism to avoid published data malicious use due to legal rules, such as privacy concerns, confidentiality, security, and so on. Government departments should monitor the quality and quantity of the published data so as to ensure full implementation of data publishing and to ensure public needs for relevant data.

Establishing a set of effective approaches for government departments involved in open data, this can provide available indicators to measure the availability of published data, such as web site availability, expected response time, quantity of published data sets, APIs runtime, and so on.

Government departments should publish data as a priority, according to main responsibilities, institutional strategy, and public needs, in order to speed up the release of high-value data sets.

## **(4) Data usage**

Achieving open data platform statistical functions for key indicators to reflect the situation of data publishing and data using, this can provide the basis for feedback and then promote the quality of data platform construction. The key indicators of statistical functions includes page views, data downloads, API calls number, user rating statistics, top ranking data resources, government departments published data statistics, and so on.

Usage metrics should include daily visits of monthly statistics, user visits of monthly statistics, data sets downloads of monthly category statistics, the trend of monthly downloads, monthly views of web site, top 10 downloaded data sets, and so on.

## **(5) Data accessibility**

Data accessibility can be measured by the feedback of public information. Public users can comment and report issues based on the clarity and completeness of existing published structured data. Other



metrical indicators should include setting mode of search keywords, use the degree of semantic web technology, detailed rating of datasets.

## 6.4 Security management

Data security management is a way to maintain the integrity of data and to make sure that the data is not accessible to unauthorized parties or susceptible to corruption of data<sup>50</sup>. Data security is put in place to ensure privacy in addition or protecting this data. Data itself is stored on network servers, possible personal computers and in the form of columns and rows. This data can be anything from personal files to intellectual property and even top-secret information. Data can be considered as anything that can be understood and interpreted by humans. Because the internet is a growing phenomenon, there was and always will be an emphasis on protecting personal or company data. Computer users, as time goes on, tend to be slightly more aware of their files, but are still encouraged to use some sort of data security. Data security methods can be acquired by using specific software solutions or hardware mechanisms<sup>51</sup>.

Data can be encrypted or unreadable to a person with no access. When encrypting this data, mathematical sequences and algorithms are used to scramble data. Encryption allows only an approved party to decode this unreadable text with a key. Only those that have this key can access any information. Authentication is another form of data security to be used for more daily access<sup>52</sup>. A sign-on to an email account, bank account etc., only allows the user with the proper key or password. The most commonly used method of keeping data protected is with data security software. This software keeps unauthorized parties from accessing private data and offers a variety of different options. Some of these options include requiring a sign-on to email accounts, rewriting of software, and being able to control security options remotely. Data can also be protected with IP security. This means that data can be protected from a hacker while in transit.

One of the biggest reasons to keep data protected is because there are many corporations that hacker want to target and breach. Data security tends to be necessary for large businesses, but the small ones usually have fewer infrastructures in place, making the information, not a great loss if breached. Depending on the services and content that is to be protected, there can be preventative measures to protect the information further. For example Windows Rights Management Services (RMS) can be set to control whether or not the recipient of an email can be read and viewed, edited, copied or saved; these setting can also set an expiration date of a specific document<sup>53</sup>.

By keeping data secured, it is possible to give different access to different people. For instance, sales associates can have access to their sales databases but are unable to access another sales associate information or business information (e.g., accounts payable, accounts receivable). Creating a single storage location (or server) for the data, and assigning individuals with different access, keeping up with data is a breeze. It makes it easier to maintain the data and permits a quick transfer to another storage location if needed. Data security software can also serve as a source to make secure sites (that give access to data files) can only be accessed by authorized personnel.

---

<sup>50</sup> Please see: <http://research.cs.wisc.edu/wind/Publications/zfs-corruption-fast10.pdf> .

<sup>51</sup> Please see: <http://datasecuritymanagement.com/>.

<sup>52</sup> Please see: <http://www.spamlaws.com/data-security.html>.

<sup>53</sup> Please see: <https://technet.microsoft.com/en-us/library/dd277323.aspx>.

### (1) Data security and privacy

Open data should focus on the application of information security standards and legal institutions of network security. The establishment of confidentiality rules and regulations for information resources, not only to strengthen the protection of information security, but also to strengthen the protection of user's personal information<sup>54</sup>. At the same time, the improvement of legal institutions can provide institutional safeguards.

Government departments, enterprises, social groups should protect personal privacy when they collect personal information, each department and agencies shall not publish personally identifiable information on the platform, also shall not violate national laws and legal rules by any means. All published data should comply with all related security and privacy requirements.

Privacy protection that is not relevant to data should guarantee the feedback provided by the platform is anonymous without recording trace information or identification information.

### (2) Data auditing mechanism

According to legal requirements, government departments, enterprises, social groups and individuals should review procedures involving data sets of national security and privacy<sup>55</sup>.

The establishment of data anonymization mechanisms to prevent linking attacks. Even if any single data set may not pose a threat to national security, or it may not cause a risk of leak privacy, it may increase this risk through a lot of published data sets. Therefore rigorous review procedures can help to reduce the risk, preventing sensitive information, personally identifiable information and national security-sensitive information being leaked intentionally or unintentionally.

The definition of secondary use of data is to permit the use the data for purposes not limited to the primary and original use. Secondary use of data by interacting data generated by different infrastructures is expected to create new services and businesses in smart sustainable city. Secondary uses of data, including location information recorded by mobile phones and data from electricity smart meters, are under consideration for new services. The location data of mobile phones will reveal the daily travels of their users. For example, some car navigation systems utilize mobile phones to connect to datacenters, and, therefore, it can obtain the car's location and other relevant data. The primary purposes of these data are to track the requirements of car's maintenance and to facilitate road services for drivers. By analyzing the data, it is possible to obtain the driving speed and location of the car. In addition, analysis of this data can identify intersections where drivers frequently brake in a sudden manner. a road maintenance squad can check the intersection by utilizing this information, where they may identify problems such as hidden or missing signs. Data from a smart meter can provide information about the daily activities of the household. Remote observation services that monitor elderly parents attract significant attention in an aging society.

Moreover, by analyzing household electric power consumption data, security companies may provide a service that alerts by e-mail when there is no consumption or when consumption is higher than usual when residents are not present at home. In addition, cleaning service of heating, ventilation, and air conditioning appliances can be provided. Such a service can use the air

---

<sup>54</sup> Raghuwanshi, D.S., Rajagopalan, M.R.MS2; *Practical data privacy and security framework for data at rest in cloud*. Computer Applications and Information Systems (WCCAIS), 2014 World Congress on. 2014, Page(s): 1- 8.

<sup>55</sup> Yu, Y., Ni, J., Au, M.H., Mu, Y., Wang, B., Li, H.; *On the Security of a Public Auditing Mechanism for Shared Cloud Data Service*. Services Computing, IEEE Transactions on. 2014 , Page(s): 1.

conditioning electric power consumption data to determine clogged filters. Eco-point services, such as discount coupons for various services, can use the data to determine incentives for households that avoid peak use of electricity. Various service providers, such as food service outlets, can also cooperate and share data with electric power companies. These examples demonstrate that the secondary use of data can potentially create new services while enhancing the data's value. From numerous viewpoints, the secondary use of data is under consideration, and its demand is increasing.

However, it is possible to know what kinds of home appliances are used in the house. Moreover, the family configuration and estimation of income could be analyzed from such data. In a smart grid and clean power conference in Britain, an executive of Siemens Energy said "We, Siemens, have the technology to record energy consumption every minute, second, microsecond, more or less live. From that, we can infer how many people are in the house, what they do, whether they're upstairs, downstairs, do you have a dog, when do you habitually get up, when did you get up this morning, when do you have a shower: masses of private data.". If such information is revealed, it may become a threat; e.g., a thief may enter the house when the residents are regularly absent.

In equal measure, this secondary use of data can result in privacy problems. In the previous examples, the location data produced by a smart phone reveals the user's location at a given time. The amount of electricity usage recorded by smart meters may reveal excessive power consumption by the household, potentially revealing their high-income status. Moreover, it is simple to publish sensitive data utilizing the Internet without proper regard to the privacy. If access to this information is not adequately restricted, it may promptly result in its unauthorized use. Aside from its usefulness, publishing the data may result in the infringement of privacy rights. Therefore, techniques for publishing the data while simultaneously protecting the privacy are required for the safe secondary use of the data.

## 6.5 Operation management

Data operation management focuses on the delicate data management of internal business processes to produce and distribute products and services. Some of activities that are covered by data operation management include data creation, development, production and distribution. Other data operation management activities include managing purchases and evaluations. A great deal of the focus of data operation management is on the efficiency and effectiveness of data's processes. Therefore, data operation management often includes substantial measurement and analysis of internal processes. Ultimately, the nature of how data operation management is carried out in a city depends much on the nature of products or services. As with all forms of management, data operation management needs to be tailored to meet the specific needs and requirements of a city. Rather, it is gained through the utilization of thoroughly developed methods and processes, and shared with all members. Many factors need considering when planning, implementing and continually developing operational processes.

Supply chain management is defined as the management of data as well data flows both in and between links in the chain, which include government, enterprise, social groups and individuals. The key issue for successful supply chain management is the effective full-scale coordination between these different partners. Such relationships are dependent on the data sharing. Issues such as purchasing prices and the levels to be purchased, as well as, storage of raw data, and other product components are to be overseen. From an operations viewpoint, all of these various processes must be reviewed frequently and improved constantly in order to ensure 'smooth', efficient operations within the city.

This report gives a specific description to three-level system of nationality, state/province, and city. The government is in the core status, enterprise and social groups are the subjects of data resource exploitation and utilization. Data resource exploitation and utilization should increase public interest as a prerequisite and should not harm the privacy of owner's data source and national security.

Open data is a kind of service system which has universal social significance. It is used not only to increase public welfare of social members, but also to enhance the competitiveness of a specialist area, or the competitiveness of the region. At the background of openness government and third-party organizations should develop a win-win cooperate mode, and then jointly maintain and develop open data. Through the cooperation establishing a service network covering the whole of society to benefit the public, this can provide the basis for social development and transformation.

Principles of business model for open data are government dominant, broad participation, and interactive sharing.

There are three specific patterns:

### **(1) Independent operation**

Independent operation pattern totally relies on the strength of government departments to operate web site. At present independent operation, pattern is often used in the government website, which requires sufficient human resources, financial guarantee, and technical support. However, this can give increasing fiscal burden to the government, and also is likely to cause technical problems and security technology due to lack of human resources.

### **(2) Cooperative operation**

Cooperative operation pattern transfer some sections of the web site to third parties, not only ensures that government seize the initiative in the central part, but also ensure that other organizations work on what they love and master by a third party. Thus it will be conducive to daily operations and update maintenance of open data, and to reduce the pressure of government staffs. In addition, to promote the development of value-added utilization of data resources, it should encourage the participation of the private sector and non-governmental organizations, simultaneously promote fair competition in the public and private sectors. Due to remarkable gap between governmental data resources and diverse demand of the general public, some of the data should be professional analysis and research because most users can not directly use the original data resources provided by government. Through filtering, organizing, and then processing the original data resources, third-party organizations can provide secondary use of data or services for individuals or other organizations to use, this can bridge the gap between demand and supply.

### **(3) Outsourcing operation**

Outsourcing operation can improve the efficiency of maintenance management through guaranteed services of professional organizations, this is a good way to cost savings and boost industrial development. Meanwhile government has a distinct advantage and effects in efficiency improvement, structures simplifies, costs reduction and professional services development.

From now on, more and more open data projects gradually from independent operation pattern to cooperative operation pattern.

## 7 Use cases

Some use cases of open data are introduced in this Section. As mentioned previously, open data are defined as the idea that the data are available for anyone can use for any purpose at no cost. Additionally, open data do not request users any management protocols such as copyrights, patents for reusing and republishing. "Open Knowledge Definition" is well-known definitions how the data can be said as open data. Table 3 shows 10 definitions of open data<sup>56</sup>. These definitions were created for smooth data use in this information society.

**Table 3 – Open Knowledge Definition**

1	Access	"Access" indicates that available as a whole as and at no more than a reasonable reproduction cost, preferably downloading via the Internet without charge. The work must also be available in a convenient and modifiable form.
2	Redistribution	"Redistribution" indicates that open access do not restrict any party from selling or giving away the work either on its own or as part of a package made from works from many different sources. The license shall not require a royalty or other fee for such sale or distribution.
3	Reuse	"Reuse" indicates that open data allow for modifications and derivative works and must allow them to be distributed under the terms of the original work.
4	Absence of technological restriction	"Absence of technological restriction" indicates that open access providers in such a form that there are no technological obstacles to the performance of the above activities. This can be achieved by the provision of the work in an open data format, i.e., one whose specification is publicly and freely available and which places no restrictions monetary or otherwise upon its use.

<sup>56</sup> Open Definition, URL: <http://opendefinition.org/od/#sthash.PmqzjbQW.dpuf> (2014).

**Table 3 – Open Knowledge Definition**

5	Attribution	"Attribution" requires as a condition for redistribution and reuse the attribution of the contributors and creators to the work. If this condition is imposed, it must not be onerous. For example, if attribution is required a list of those requiring attribution should accompany the work.
6	Integrity	The license requires as a condition for the work being distributed in modified form that the resulting work carry a different name or version number from the original work.
7	No discrimination against persons or groups	The license does not discriminate against any person or group of persons.
8	No discrimination against fields of endeavour	The license does not restrict anyone from making use of the work in a specific field of endeavour. For example, it may not restrict the work from being used in a business, or from being used for genetic research.
9	Distribution of license	The rights should be attached to the work must apply to all to whom it is redistributed without the need for execution of an additional license by those parties.
10	License must not be specific to a package	The rights should be attached to the work must not depend on the work being part of a particular package. If the work is extracted from that package and used or distributed within the terms of the work's license, all parties to whom the work is redistributed should have the same rights as those that are granted in conjunction with the original package.
11	License must not restrict the distribution of other works	The license does not place restrictions on other works that are distributed along with the licensed work. For example, the license must not insist that all other works distributed on the same medium are open.

One of brilliant achievement of arising open data movement was "Data.gov" that is a portal site established in the United States in 2009. The movement was provoked by "Open Government Initiative" that President Obama declared for smooth data use. Examples of the data utilization are (1) making web applications for business, (2) utilization of research, for instance, predictions of climate change.

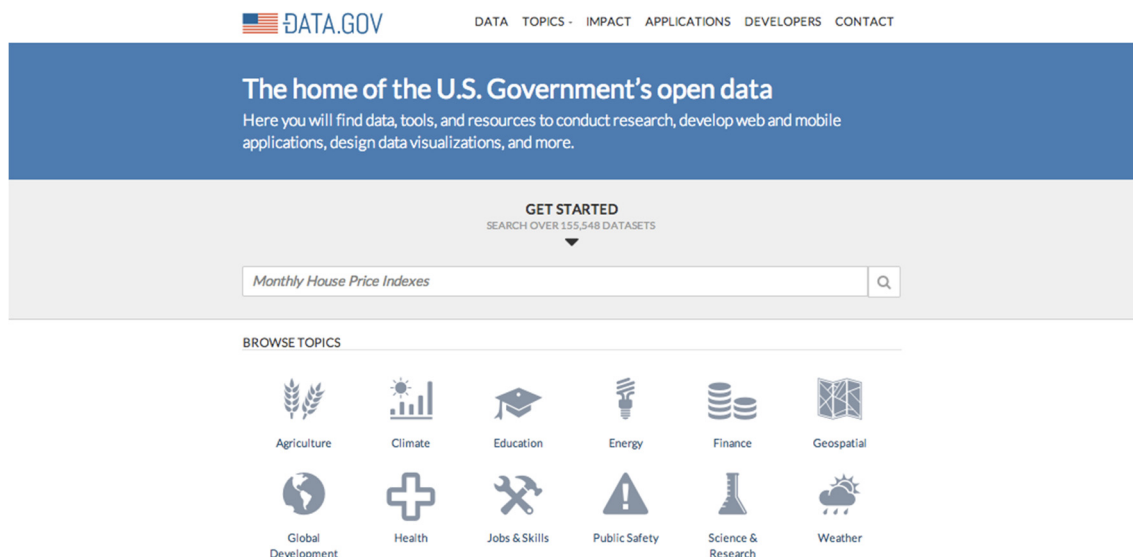
The data include high publicness data, for instance, government data. More detailed information will be described in 7.1 that describes Data.gov in the United States. After this movement, the other countries have started to develop portal sites to provide the government data. The detailed information will be introduced among 7.2 that describes the U.K case, 7.3 that describes Japanese case, and 7.4 describes Chinese case.

## 7.1 Case study 1. Data.gov

Data.gov is a portal site, which can download many types of government data for the utilization for businesses, researches, and the other purposes. A background of arising open data movement was "Open Government Initiative" that President Obama declared on May 2009. This initiative has three



main policies (1) transparency, (2) participation and (3) collaboration<sup>57</sup>. After the initiative, "Data.gov," which is a portal site that people can download the government data sets. The government data indicate that the federal offices have collected, for instance, data from national census, environment, and economic conditions. Figure 3 is a capture of the website.



**Figure 3 – Capture of the Postal Site, Data.gov**

The government presented "Open Government Directive" to each the federal offices for sharing the data among any people, researchers, and companies via the Internet on December 2009. After the directive, Data.gov has published the government data, which categorized four data of raw, geo, data tool, and interactive. Users can select the type of data, public institution, data categories, topics, and web domains. Table 4 shows examples of data categories.

**Table 4 – Example of Data Categories**

	Categories
1	Transportation
2	Environment
3	Crimes
4	Medicine
5	Education
6	Nutrition
7	Security

<sup>57</sup> Digital Government: Building a 21st Century Platform to Better Serve the American People, URL <http://www.whitehouse.gov/sites/default/files/omb/egov/digital-government/digital-government.html> (2014).

After sharing the data, new businesses have arisen, which were similar movements like that many weather news businesses started after National Oceanic and Atmospheric Administration opened their data. As the recent case, many new businesses have started up with data of "Health Data Initiative" shared<sup>58</sup>.

One of the examples to utilize the open data of energy usage is "Opower"<sup>59</sup>. They have used energy consumption data, which are collecting by smart meters, and made reports how to conserve the energy for companies and households. Their analyzed data are almost free. Therefore, their running costs are dramatically low compared with before. They have expanded their business to seven countries and had 16 million customers in 2013.

## 7.2 Case study 2. Data.gov.uk

"Data.gov.uk" is a portal site that the government has shared public data. However, their purpose includes enhancing the people's understanding how government works and how policies are made. Data.gov.uk is placed as a key part of the government's work on "transparency" between the government and people. Open data team in the Cabinet Office has led Data.gov.uk. Figure 4 shows a capture of top page, Data.gov.uk.

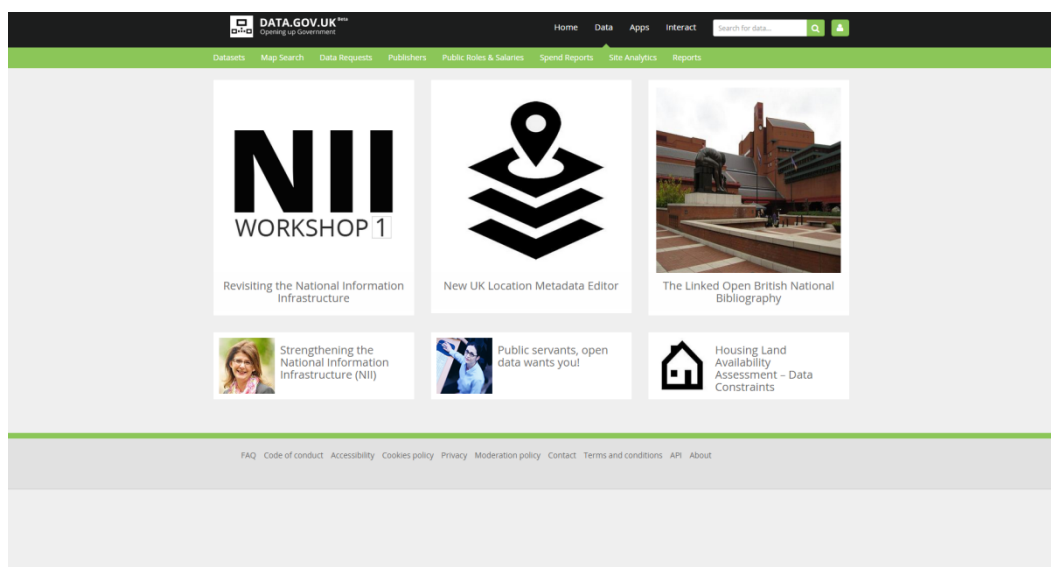


Figure 4 – Capture of postal site, Data.gov.uk

The government is releasing public data to help people understand how government works and how policies are made. Some of this data is already available, but Data.gov.uk brings it together in one searchable website.<sup>60</sup> Data.gov.uk provides datasets available from all central government departments and a number of other public sector bodies and local authorities. From the portal side of data.gov.uk, users can access the raw data driving government forward like Data.gov provided by the United States. Examples of general public information are tax credits or tax your car.

<sup>58</sup> Health Data Initiative, HelthData.gov, URL: <http://healthdata.gov/> (2014).

<sup>59</sup> Opower Official Website, URL: <http://opower.com/> (2014).

<sup>60</sup> Data.gov.uk, URL: <http://data.gov.uk/about> (2014).

The portal site also enhances the utilization of data for analyzing trends within various policy areas, and for comparing how different departments of the government go about their work.

Additionally, technical users will be able to create useful applications using the raw data files, which can be accessed by everyone.

### 7.3 IT dashboard

"IT dashboard" is a portal site that National Strategy Office of Information and Communications Technology in Japanese government created. This movement arose by "Declaration to be the World's Most Advanced IT Nation" on June 2013<sup>61</sup>. Figure 5 shows a top page of IT dashboard.



Figure 5 – Capture of Postal Site, IT Dashboard

This declaration indicated that people living in Japan would be contributed by ICT; therefore quality of ICT should be higher. The purposes of this declaration are introduced below:

- (1) Contributing to the creation of new industry and growth in all industry fields through the creation of innovative technologies and integrated services that will enable the public to experience personally the recovery of the Japanese economy through the use of IT and data;
- (2) Contributing to the improvement of the world's safest and most disaster-resilient society where people can live safely, with peace of mind, and comfortably; and
- (3) Contributing to the provision of electronic government services and government reform from the perspective of user public to enable one-stop public services that anyone can access and use from anywhere.

In order to provide the data sets, the government developed a website "IT dashboard"<sup>62</sup>. 15 federal offices shared the data sets via the website. Categories and percentages of the open data are geographical data (33.0%), static data (28.1%), white paper (14.1%), protection against disasters (14.7%), technical data of using IT dashboard (7.0%), and the other (2.2%). Used data formats are pdf, html, xls, gif, csv, pdtxt, zip, epub, jpg, xlsx, ppt, docx, pdf", and mp3.

<sup>61</sup> Declaration to be the World's Most Advanced IT Nation, URL: [http://japan.kantei.go.jp/policy/it/20140624\\_declaration.pdf](http://japan.kantei.go.jp/policy/it/20140624_declaration.pdf) (2014).

<sup>62</sup> IT dash board, National Strategy Office of Information and Communications Technology, URL: <http://www.itdashboard.go.jp/> (2014).

## 7.4 Open data movement in China

There were only three non-user friendly government open data sites and a smattering of open data enthusiasts who often had to find their own data sources and even create hardware to generate their own data in China. They were not a formally connected group but rather, individuals who created open data apps out of personal interest. Now, the recently launched open data community is trying to create a multi-disciplinary network of businesses, research institutes, and NGOs interested in open data.

The open data community is currently working on three projects, one of which is a comprehensive timeline of open data in China where OFKN China has potentially traced the open data "movement" to its beginnings. According to the timeline, the Chinese government's first open data website was Shanghai's internal data directory launched sometime around September 2011, though the date is not clear. The government does little to publicize the launch of these sites. The current data list includes 425 data sets. The Shanghai government later released some data on the Shanghai data portal (see Figure 6), launched in December 2012. Beijing's open data site went online in October 2012 with 4,000 datasets to date, followed by that of the National Bureau of Statistics site in September 2013.

Several months later, China held its first ever hackathon using public data called code for climate change. The creator of a hackerspace called Xindanwei, meaning 'new work unit,' which is a play on the government work units. This is the first time that the government is providing all this data to the start-up and creative community and is working together with them by providing data sets. Also, top researchers from all over China are providing insights and knowledge.

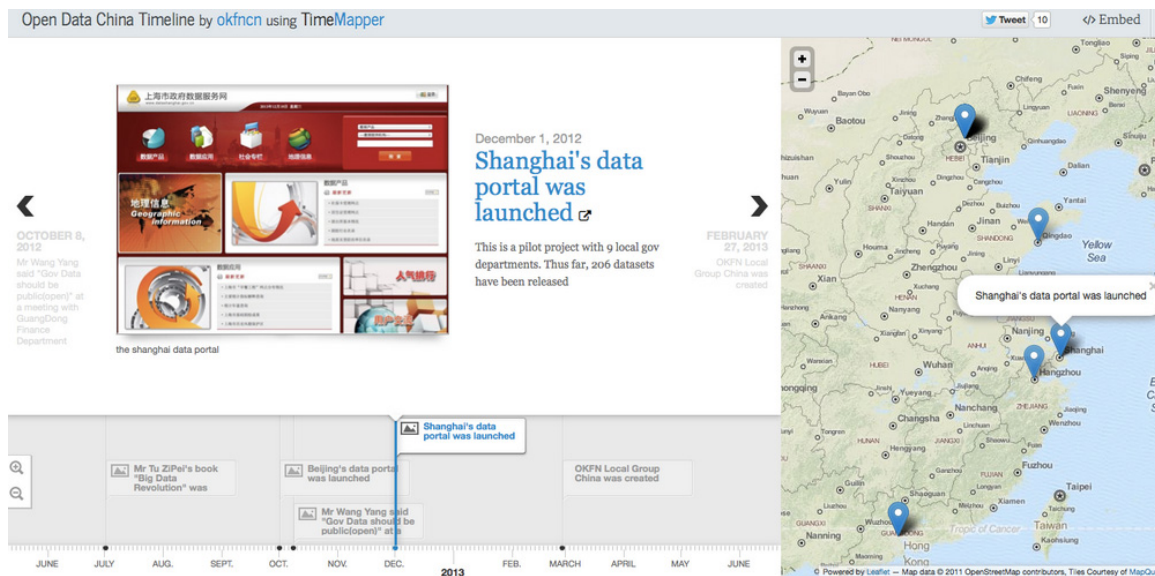


Figure 6 – The timeline provides the history of open data in China

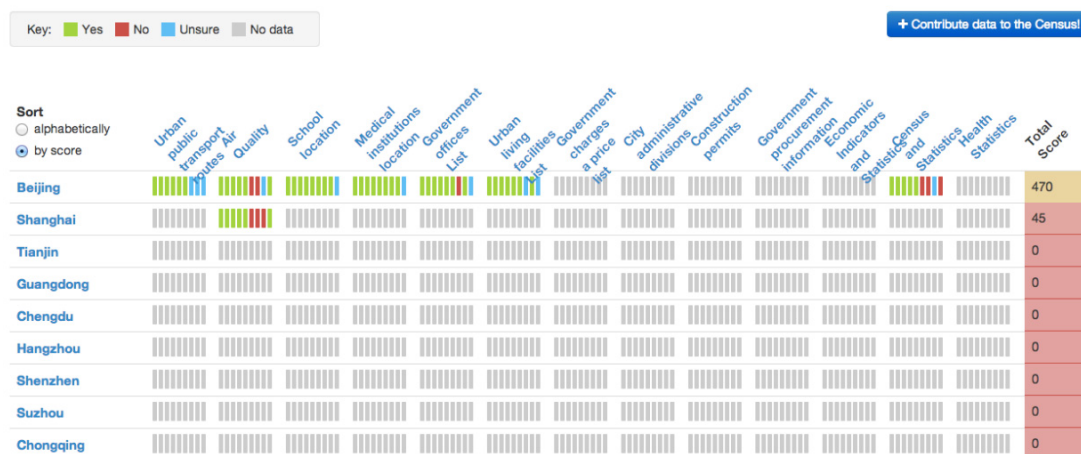


Figure 7 – The color-coded to show open data's availability in China

Before you can begin to use data, you have to know what's available. So another ongoing project of the open data community is a graded survey of all available data in major Chinese cities based on a number of categories such as urban public transportation, air quality, census, health, and economic indicators, among others. As of now, of the two cities that have been graded, about 50 percent of their datasets are open (see Figure 7), meaning they are machine-readable. Still, the open data community hopes that after making a coordinated effort to clean up the data, it will encourage civil society to use it and that the open data community can serve as an incubator for data apps and projects<sup>63</sup>.

In the last decade, a few pioneers in library and information institution have introduced the idea and principles of semantic web and linked data technology into practice. Some researchers in National Library of China, Institute of Scientific and Technological Information of China and Shanghai Library have done several experimental projects to implement linked data. However, there is no practical system that can provide online services by the end of 2014.

Shanghai Library has initiated a project that aimed to establish a genealogy system based on Linked data architecture and the related semantic technologies. There are substantial genealogy materials collected by Shanghai Library. Genealogy contains rich information about families and local history, such as the ancestors, notable people, events, family members migration information, etc. Shanghai Library has the biggest Genealogy collection in China. However, the database is based on MARC format, which is the standard bibliography format for Library resources in the last six decades. It should be transformed into a RDF-enabled format so as to be applied to the up-to-date semantic technology.

With the development of digital humanity and semantic web, the old database based on MARC related technologies are outdated for its obsolete data model. It cannot deeply reveal the properties of the content of genealogy resources, and also cannot encode the relationship among the entities (people, places, temporal, and events etc.). The linked data technology is the feasible solution to resolve the problems. As the lightweight solution of semantic web, linked data<sup>64</sup> is rooted in the

<sup>63</sup> Please see: <http://techpresident.com/news/wegov/24940/China-Open-Data-Movement-Starting-Take-Off>.

<sup>64</sup> Tim Berners-Lee. Linked Data [EB/OL]. 2011-05-15. <http://www.w3.org/DesignIssues/LinkedData.html>.

existing basic technologies of web. In linked data architecture, all resources are identified by URI, which act as not only the unique name of the resource on the web but the locator to access the resource as well. The information about the resource is encoded with RDF data model (sometimes can be normalized with OWL encoded ontologies to represent domain knowledge). Its serialization can be understood by machine and indicate the relationship among resources.

Shanghai Library has published a genealogy ontology based on BIBFRAME model and vocabulary. BIBFRAME was initiated by LOC and other libraries as the next generation bibliography framework intended to replace MARC. It provides the possibility to bring the old-fashioned bibliographic data on the semantic web, as a linked data service. Currently, Shanghai Library has developed a practical data model with RDF, and start to map the genealogy data into RDF. Now a demo system is under construction. It aims to publish the authority controlled data and bibliography data as linked data, and to establish an exhibit layer to access and search the data by multiple facet such as people, place, time, etc. It will provide a SPARQL endpoint to facilitate querying triples. There is also provided a data visualization tool to display the relationship of the data Shanghai Library will keep on applying semantic web technologies to build its digital humanity platform. The genealogy linked data system acts as a demonstrative solution to recognize the traditional library can fit into semantic web with its rich, treasured and sophisticated resources.

## 7.5 Open data services with privacy data and anonymization

In this section, we explained how open data are protected. Basic ways of data and information anonymization are shown in Table 5.

**Table 5 – Ways of information anonymization**

1	Replacement	Substitute identifying numbers
22	Suppression	Omit from the released data
33	Generalization	Replace birth date with something less specific, like a year of birth
44	Perturbation	Make random changes to the data

These technologies are necessary to utilize the open data with privacy because the government data includes the people's privacy. In order to create "Smart Sustainable City," this point should have careful consideration. For a reference, we introduce a coding event of "Open Data for Development Challenge" which was held in Montreal, Canada on January 2014<sup>65</sup>.

The Foreign Affairs, Trade and Development Canada (DFATD) was hosting this 36 hours "codathon" bringing together Canadian and international technical experts and policy makers. The event enhanced to generate new tools and ideas with the open data and aid transparency among the users. This kind of events has held in the countries, which have promoted the movement of the open data.

In Japan, several smart cities project including the services using open or private data are conducted. Here two projects are shown as examples. Kawasaki city, Kanagawa prefecture conducts Kawasaki smart city project. This project picks up three areas in this city and drives different and localized smart city projects. One is the area of the bay of chemical and oil industries. Hydrogen pipelines and delivery system interconnect different factories and shares the energy of hydrogen and electric

<sup>65</sup> Open Data for Development Challenge, Foreign Affairs, Trade and Development Canada, [URL:http://www.acdi-cida.gc.ca/acdi-cida/acdi-cida.nsf/eng/DEN-1223131242-PCZ](http://www.acdi-cida.gc.ca/acdi-cida/acdi-cida.nsf/eng/DEN-1223131242-PCZ) (2014).



power generation between them. One is the area of center station of Kawasaki, and it drives cluster energy management system with aggregation service of energy management data. The aim of this area is to achieve effective use of electricity and reduce the amount of the use. The last area around Musashi-Kosugi uses data anonymization of private data. Kawasaki city has shared their data via the website "CityData"<sup>66</sup>. They shared the data sets of protection against disasters included places of shelters, temporary evacuation facilities), meteorology information, disaster prevention information, such as water stage in a river, rainfall, the place of firehouses, fire prevention water tanks, population statistics, industry statistics. Moreover, information directly connects to usual life, such as receptions, garbage separation and collection, and governmental information. Especially in Musashi-Kosugi area, Home energy management system (HEMS) is introduced into the houses in this area and gathers the data from its smart meter to use as localized services by anonymizing with the data sets. HEMS is a core device to recommend the effective use of electricity to households. However, the households become tired with the information and come to ignore the information. Frequent check of the information of HEMS is indispensable to reduce the use of electricity as self-action. The specialized HEMS in this area show the information of the data sets and life information as summarized and customized information to change it into fascinating information. Moreover, the data captured by a smart meter is gathered and anonymized to use as the watching services of elder families and persons, door-to-door delivery services to optimize their delivery route by checking the houses' stay, ads and recommendation services, and insurance services for households.

Kurihara City, Miyagi Prefecture conducts green society ICT life infrastructure project. This project aims the integration and sophistication of medical, energy, agriculture, climate, local government, disaster prevention infrastructure, and designs information management system as a cloud service are designed as the core of this infrastructure. This system utilizes standards and supports several new smart sustainable city services by providing open interfaces for data analysis and anonymization. Here, several examples of its application are provided.

This system enables to predict the number of patient of thermic fever in the area by learning the trend of a number of the patient and weather information and assembling the climate prediction data. This result enables the city government to predict and prepare required emergency medical services and number of hospital beds in the future. This result also helps the design of future medical services. As the application of this data, elder people are likely to catch a thermic fever easily because they do not feel and think heat. It causes frequent return to the hospitals. Energy management system and smart agricultural system monitors the temperature, humidity and other environmental information by embedded sensor networks. In the future, doctors will use these environmental information to use as a lifestyle recognition and guidance for the elder peoples to prevent frequent return to the hospitals.

Another application is energy area. The system gets the information that the power consumption of this area increases by 4% 50 years later.

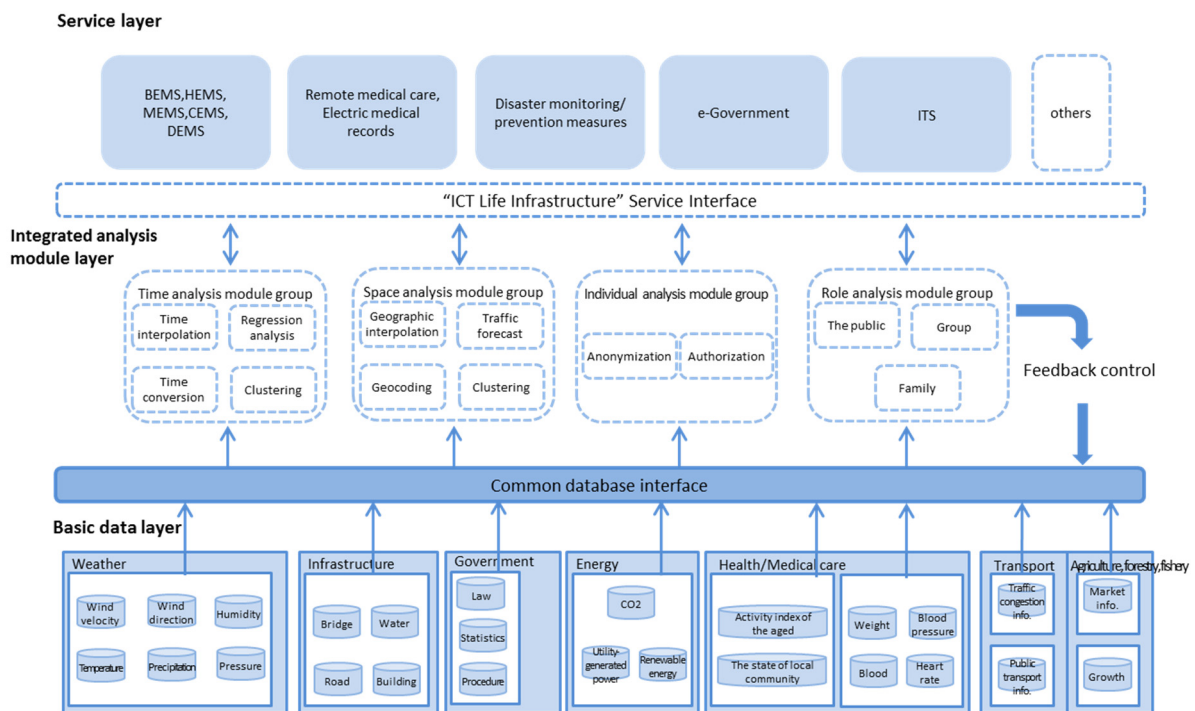
Hence, applied systems are also proposed. For example, a prediction of data of methodology prediction and energy demand showed 4% higher after 50 years. Additionally, a prediction of increasing hot summer days by eight times showed 4% higher demand converges on summer, it means that electrical power problems would be increased. For the reason of that, demand response

---

<sup>66</sup> Kawasaki City Open Data, Kawasaki City Office, URL: <http://citydata.jp/%E7%A5%9E%E5%A5%88%E5%B7%9D%E7%9C%8C/%E5%B7%9D%E5%B4%8E%E5%B8%82> (2014).

services, which have methods of peak cuts and so on, would be enriched. Sensing for cultivated lands would lead the problems of variety selection and relationships between of people's health and farm work in the agriculture field.

"Social capital" is an important factor in local communities in sociology. The concept of the word indicates importance that relationships of mutual trust and social structure in local areas and communities. In order to calculate indexes of social capital, holding questionnaire is one of the ways to make the indexes. Former studies showed a relationship between medical treatment and social capital has significantly interrelated. If one area or community has high index of social capital, aged people are relatively healthy, and if the hospital actions are taken there, the ratio of improvement is higher compared with areas and communities where low ratio of social capital index has. A map layered indexes of social capital in Kurihara-city was created and used for long-distance health guidance using ICT. These results indicate that installing HEMS and community grids to the areas and communities having the indexes of social capital would have the possibility to be a success more than the areas and communities having the lower indexes. Moreover, social capital indexes can utilize not only electricity conservation and a predication of sunstroke prevention using comfort indexes that are different depending on the people.



**Figure 8 – Management infrastructure model for data of smart sustainable city originally created by Prof. Uehara, Keio University, Japan**

Here, the secondary use services in the world are given. Canada has two laws for privacy preservation: Privacy Act for government institutes and Personal Information Protection and Electronic Document Act (PIPEDA) for private companies. Montreal city in Quebec introduced Opus, an IC card for domestic transportation services in 2008. Then provided a mobile application "STM

Merci". This application offers personalized information like shops, concerts, other events. These services use Opus card user information, such as using lines, age, and sex to personalize the information. The user can select the "offers" of the application, and they can get a recommendation and discount tickets of the shop. The major of partner companies as a service provider is bicycle/car sharing services, events, and shops.

These services are well-known in smart phone application by using the personal information. In some cases, private information is used to provide rich services. The utilization rate of the offer is about 4%, and it is twice as large as other general one-to-one marketing. Concordia University in Montreal also leads several approaches using private data with data mining in healthcare field.

Ontario State sells private information of healthcare to private companies and provides it to public institute or organization for free of charge. Personal Health Information Protection Act (PHIPA) permits the secondary use of health data by anonymizing it. This data is provided by using k-anonymity, and privacy analytics risk assessment tool (PARAT) was used to confirm the risk of data. One of the schemes is the use in The Children's Hospital of Eastern Ontario (CHEO). The Canadian Institutes of Health Research (CIHR), the National Science and Engineering Research Council (NSERC), and the Social Sciences and Humanities Research Council (SSHRC) issues the guidance of research ethics for the use of secondary medical data.

In US, Federal Trade Commissioner is developing laws prevents the illegal use of private data according FTC Act. Health Insurance Portability and Accountability Act (HIPAA) of US takes similar approaches with Canada

In UK, Information Commissioner Office of UK Ministry of Justice supports the penetration, justice, regulation of data privacy. In medical area, UK National the Health and Social Care Information Centre (NHS IC) supports Secondary Uses Service (SUS) and Pseudonymization Implementation Project (PIP). These laws support the secondary use of medical information under the supervision of UK government.

## **8 *Expected (anonymous) applications of open data in smart sustainable cities***

---

### **8.1 *Application of open data on smart forecasts***

The Climate Corporation in San Francisco originally called WeatherBill was started to sell powerful software and weather insurance, but it's grown into a company that could help farmers around the world adapt to climate change, increase their crop yields. The company's proprietary technology platform combines hyper-local weather monitoring, agronomic data modeling, and high-resolution weather simulations to deliver climate.com, a solution that helps farmers improve their profits by making better informed operating and financing decisions, and Total Weather Insurance, an insurance offering that pays farmers automatically for bad weather that may impact their profits. It is a perfect example of open data application that shows what government data can tell them. The Climate Corporation can display hundreds of different data-driven views of the planet through some projectors, showing changing wind patterns, temperature, ocean currents, or whatever you'd like to look at. In the face of increasingly volatile weather, the company provides farmers with the industry's most powerful full-stack risk management solution depends on the company's unique technologies to help stabilize and improve profits and, ultimately, help feed the world. With a few exceptions, data that fuel the company are freely available to anyone.

The company started by working with data from 200 weather stations across the country. As a prospective policyholder, a business would go to the company's website, pick a nearby weather station, and buy insurance against bad weather that the station would measure. The company would analyze historical weather data for that station, predict the likely weather mathematically, and write an appropriate policy. Farmers in the United States generate about \$500 billion a year in revenue, and they make about \$100 billion a year in operating profits. So farming is about a 20-percent-margin business on average. The one source of variability for revenue nowadays is the weather, because all the other risks of farming have largely been eliminated through herbicide, fungicide, and insecticide technologies. Weather can be a very big driver for outcomes: farmers can end up losing everything. Slight variations in weather can cause significant losses in profit. Moreover, farmers were significantly underinsured under the federal crop program.

As The Climate Corporation began to turn its attention to farmers, the company found that data from 200 weather stations across the United States was not precise enough to model the weather at local farms. They expanded to get data from 2,000 stations, but that was still not enough. So they used what is called Common Land Unit data that shows the location, shape, and size of all the farmed fields in the country. Even though this is free, public data, it took many Freedom of Information Act requests and collaboration with Stanford University and other research institutions to get the U.S. Department of Agriculture to release it. Next, The Climate Corporation used government data to assess the weather at all those fields more precisely. Using Doppler radar, it is now possible to measure how much rain falls on a given farmer's field in a day, to an accuracy of almost 1/100th of an inch. The company also got maps of terrain and soil type from the U.S. Geological Survey, built from on-the-ground soil surveys and satellite images, which give accurate pictures of squares of land 10 meters on a side. Farmers don't necessarily care about how much rain fell. "What they really need to care about is how much water is in their ground," which is determined by both rainfall and the soil. Their goal is to be able to increase a farmer's profitability by 20 or 30 percent – a huge increase in this vulnerable industry.

In the end, it can seem like a conundrum: the U.S. government has invested huge amounts to generate data, but it is taken a private company to put the data to use. In fact, though, this is exactly how many advocates for open data think it should be. You have to go outside the government to use the capitalist economic model that says, Take a risk and make more return. However, without government support, none of that innovation could happen. In the government provide infrastructure services. That final point is a critical one. Through an open data infrastructure, government can spur innovation by providing the foundation for data-driven businesses. It is been true for GPS and weather data, and it is starting to be true for health data as well.

## 8.2 Data anonymization for smart sustainable city

Anonymization is one of the methods included in PPDM and PPDP. This method protects sensitive information by masking or generalizing the sensitive data. In addition, it allows the adjustment of the privacy protection level. There are several generalization methods available for anonymization. In the following paragraphs, two relatively basic and frequently referenced generalization methods, - anonymity and -diversity are explained.

## (1) Anonymity

Anonymity is one of the methods utilized for generalization<sup>67</sup>, and it is the base of l-diversity. Further explanation of this method will incorporate the various definitions listed below.

(i) Data table:

A data list similar to a database table is termed a "data table." Its column is termed an "attribute." Address, birth, and gender are examples of attributes. One group of data corresponding to the person or group of people is termed a "data set" and one data set is termed a "tuple".

(ii) Attribute:

An attribute among a group of related attributes that can identify a corresponding person by itself, such as name or unique ID, is termed an "identifier," and others that cannot identify a group on their own, however, it can provide identification when combined with other attributes, such as illness, birth, gender, is termed a "quasi-identifier".

(iii) Sensitive attribute:

A significant attribute for secondary use is termed a "sensitive attribute," which can be selected from attributes that are not identifiers. The method will exclude this attribute from masking or generalization by anonymization. Furthermore, tuple groups that have the same quasi-identifier values are termed "q\*-block".

The definition of k-anonymity is as follows: "In each q\*-block in the data table, at least k tuples are included".

Table 6 represents an example of a medical records data table. In this table, the sensitive attribute is "Problem" and the quasi-identifiers are "Birth," "Gender," and "ID." The data consists of a t1~t3 q\*-block, a t4, t5 q\*-block, and a t6, t7 q\*-block. It represents k=2. Even if an attacker attempts to ascertain a specific individual's problem and has already obtained the individual's quasi-identifier, the attacker can narrow the results down to only two tuples. Table 7 indicates that the anonymization results from Table 6 are k=3. The results displayed in this table demonstrate that anonymization methods provide the required privacy protection level, utilizing masking or generalization.

**Table 6 – Medical record**

Birth	Gender	ID	Problem
1970	Male	121	Cold
1970	Male	121	Obesity
1970	Male	121	Diabetes
1980	Female	121	Diabetes
1980	Female	121	Obesity
1981	Male	125	diabetes
1981	Male	125	Cold

<sup>67</sup> L. Seeney; *K-anonymity: A model for protecting privacy*; International Journal on Uncertainty, Fuzziness and Knowledge-based Systems, vol. 10, no. 5, pp. 557–570, 2002.

**Table 7 – Anonymized medical record**

Birth	Gender	ID	Problem
1970	Male	121	Cold
1970	Male	121	Obesity
1970	Male	121	diabetes
198*	Human	12*	diabetes
198*	Human	12*	Obesity
198*	Human	12*	diabetes
198*	Human	12*	Cold

As displayed in these tables, the masking or generalization processes prevent an attacker from identifying a specific person. There are several algorithms for calculating masking or generalization. The most popular algorithm is the heuristic searching method, utilizing double-nested loops.

## (2) Diversity

Diversity is a method designed to protect the privacy of data<sup>68</sup>. This method considers the diversity of sensitive attributes, and it is, therefore, different from -anonymity.

The definition of -diversity is as follows: "In all  $q^*$ -blocks in a data table, there are at least  $l$  different sensitive attributes."

Researchers designed this method to provide protection from the following attacks.

(i) Homogeneity attack:

Table 8 is an additional example of a medical record data table. In this case, if an attacker has acquired Alice's quasi-identifier, the attacker can read Alice's problem from this table because no diversity exists for the sensitive attributes in the  $q^*$ -block.

(ii) Background knowledge attack:

Although the  $q^*$ -block in the table has a diversity of sensitive attributes, if the probability of poor circulation is very low for males and an attacker is aware of that, the attacker can read Bob's problem from the table.

$l$ -diversity provides more security than -anonymity for preserving privacy. However, the calculation cost of  $l$ -diversity is higher than anonymity.

<sup>68</sup> Ashwin Machanavajjhala, Daniel Kifer, Johannes Gehrke, Muthuramakrishnan Venkatasubramaniam; *L-diversity: Privacy beyond k-anonymity*; ACM Transactions on Knowledge Discovery from Data (TKDD), Vol. 1, No. 1, 2007.



**Table 8 – Anonymized medical record**

Birth	Gender	ID	Problem	
1970	female	121	Cold	Alice
1970	female	121	Cold	
1970	female	121	Cold	
198*	human	12*	poor circulation	Bob
198*	human	12*	poor circulation	
198*	human	12*	Headache	
198*	human	12*	Headache	

The demand for the secondary use of the data such as medical records is increasing, because it may enable the estimation of infection routes. However, medical data frequently includes sensitive and private information. The medical data providers should define the anonymization methods and the related privacy protection levels when publishing the data. In addition, when the data provider permits several methods of anonymization, the consumers of the data must select a method that matches their requirements. Moreover, consumers of the anonymized data should avoid obtaining private data that exceeds their requirements, including situations where the data provider permits the lower protection level and thus provides the private data. Therefore, the anonymization data infrastructure should provide a method to define anonymization methods and protection levels that fulfil the requirements for both data providers and data consumers.

In order to meet these requirements, data publishing with anonymization is required. However, PPDP utilizing anonymization has numerous problems. One of the problems is that no protocols and formats currently exist to enable secure data publishing, as described in the introduction. The other is loss of anonymity by publishing the same data multiple times. Table 6 is an example of a medical record data table. Table 7 is an anonymized data table with data from Table 6, and Table 8 is another anonymized data table with data from Table 6. In this case, those who can obtain both the anonymized data of and  $k=3$  can obtain the data, including situations where the data provider did not permit the publishing of  $k=1$  data. This results in the leak of privacy information. One cause of this problem is that previously published data is not referenced in the anonymization process; as a result the coherence between the and  $k=3$  data was severed. Table 9 is another example of a  $k = 3$  data table. Utilizing Table 9 instead of Table 8 avoids the problem described above. Table 9 was generated by anonymizing Table 7 instead of anonymizing Table 6, to maintain coherency in masking and generalization. This anonymizing process can prevent further leaks of privacy information.

To address these problems, a data-publishing infrastructure is shown as a solution. It manages the previously published data for the anonymization without the loss of anonymity and provides safe secondary use and anonymization. For encryption technology, it utilizes public key infrastructure (PKI). Certificate authority serves a function as an authorized organization for certifying the public key of servers on the Internet. For this discussion, the anonymization technology and this infrastructure can be associated with the encryption technology and PKI, respectively.

**Table 6 – Medical record**

Birth	Gender	Problem
1970	Male	cold
1970	Male	obesity
1970	Male	diabetes
1981	Male	diabetes
1981	Female	obesity
1982	Female	diabetes
1982	Female	cold

**Table 7 – Anonymized medical record**

Birth	Gender	Problem
1970	Male	Cold
1970	Male	Obesity
1970	Male	Diabetes
1981	human	Diabetes
1981	human	Obesity
1982	female	diabetes
1982	female	Cold

**Table 8 – Anonymized medical record (1)**

Birth	Gender	Problem
19*	Male	cold
19*	Male	obesity
19*	Male	diabetes
19*	Male	diabetes
198*	female	obesity
198*	female	diabetes
198*	female	cold

**Table 9 – Anonymized medical record (2)**

Birth	Gender	Problem
1970	Male	cold
1970	Male	obesity
1970	Male	diabetes
198*	Human	diabetes
198*	Human	obesity
198*	Human	diabetes
198*	Human	cold

### 8.3 Application of anonymization method for smart metering

Recently, owing to the evolution of cloud services, discussion of secondary uses of data has attracted attention, especially for big data. However, preserving privacy is a significant problem. As a typical application, here we have focused on demand response services in a smart grid as a promising application of smart sustainable city.

The introduction of a smart meter has been considered and achieved around the world. It manages the energy use of a home to achieve a balance between energy saving and a comfortable lifestyle. Smart meters have a communication function to transmit the electric power consumption of a household at regular intervals. The primary use of smart meters is for fare correction. In this case, power consumption data should be collected without loss of data. This means that private information is included in the data.

Demand response (DR) is a typical application of the secondary use of electric power consumption data measured by a smart meter. DR can achieve peak-cut and peak-shift of electricity use by changing the price of electricity or by providing incentives to encourage customers to change their normal consumption pattern when demand for electric power is high. Variable pricing may encourage consumers to reduce electricity consumption and will provide an opportunity to think more about how and when we use electricity. Electric companies or aggregators create DR messages to households according to their current electric power demand. An operation test conducted in the United States demonstrated electric power demand reduction of 10-20%<sup>69</sup>. DR can be achieved using electric power consumption data transmitted from residential smart meters.

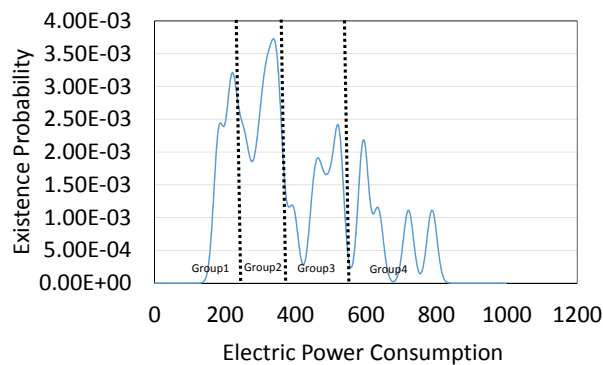
As an example of DR, electric power consumption will be used widely for secondary use due to its flexibility in applications. The cost of introducing smart meter and devices to control home electric appliances is comparatively higher than the reduction cost of electricity by itself. DR services use a smart meter, which is an electric power meter with a communication function to transmit the electric power consumption of a household to a datacenter. This power consumption data can be used to develop and exploit new services. Recently, secondary use of such data has been considered for such services. DR services are not only for electric companies that collect raw data from smart meters. For other companies, collecting private information with such meters is prohibited. To avoid disclosing private information, it is sufficient for such companies to use generalized or anonymized data if the quality of their services can be guaranteed. However, as described in section 7, electric power consumption data must be treated with significant care. An anonymizing method for electric

<sup>69</sup> Yuichi Nakamura, Kanae Matsui and Hiroaki Nishi; *Anonymization Infrastructure for Secondary Use of Data*; ICOMP'14 - The 2014 International Conference on Internet Computing and Big Data, 2014.

power consumption data that preserves personal information can be given as an example. This method converts data to distribution data by considering anonymity<sup>70</sup>.

Here, as an example, a new anonymizing method for electric power consumption data. This method anonymizes data using the following steps. First, this method generates clusters using  $k$ -member clustering<sup>71</sup>. After member clustering, the average and width of each cluster can be extracted. By using this parameter, existence probability can be generated from the average and width of each cluster. At this time, the width is modified to control the anonymization level. After creating the existence probability for all clusters, a convolution is given to all clusters. All existence probabilities created from each cluster is summed up and transformed the area generated in this summation process into 1.

In order to achieve DR, one major solution is to change the price of electricity or to provide incentives to encourage customers to change their typical consumption pattern when electricity demand is high. Using this anonymized electric power consumption distribution, a DR service can be provided without obtaining raw data. From historical power trends of anonymized data, it is still possible to predict electric power demand for the next 30-min interval. When the predicted value exceeds a threshold, the system sends a reduction message as a DR message. Figure 9 shows the image of the anonymized data of electricity consumption distribution of all houses. In this graph, both numbers of houses and power consumption of each house are hidden. In this figure, the DR control group is also given, and different DR signal is issued by these four groups independently. Namely, group 4 will receive DR message with higher reduction than other groups to observe graduated DR for maintaining fairness. This method also reduces the total calculating cost of DR and number of messages and occupation throughput of network.



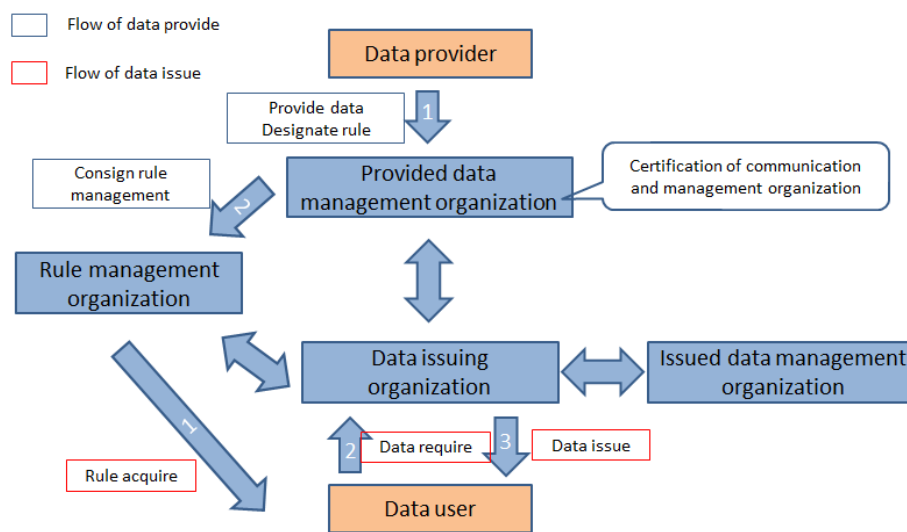
**Figure 9 – Threshold value for clustering**

<sup>70</sup> T. Hattori, N. Toda; Demand response programs for residential customers in the United States—Evaluation of the pilot programs and the issues in practice; March 2011.

<sup>71</sup> Kengo Okada and Hiroaki Nishi; *Big Data Anonymization Method for Demand Response Services*; ICOMP'14, The 2014 International Conference on Internet Computing and Big Data, 2014.

## 8.4 Infrastructure of Secondary Use of Data

This infrastructure can be divided into four organizations as follows (Figure 10)<sup>72</sup>.



**Figure 10 – Overview of data anonymization infrastructure**

(i) Original data storeroom organization (ODS)

This organization manages data provided by the data folder. The data folder is considered the data provider when the data is managed by ODS. When providing data to ODS, the data folder prepares data for publishing and provides an allowance rule by utilizing a specially designed format. This format is termed XML-based anonymization sheets (XAS). The details of XAS are described in the following section. Publishing rule descriptions utilize a subset of XAS, termed XML-based anonymization rules (XAR). The data folder generates data as D-XAS, and the publishing rules (P-XAR) correspond to the D-XAS. D-XAS should include the link to the P-XAR. ODS should be responsible for maintaining the original data written as D-XAS in a secure manner. This data registration process is based on the PUT method.

(ii) Anonymizing rules storeroom organization (ARS)

This organization manages P-XAR. P-XAR will be openly published for users who need to access anonymized data based on the original data. P-XARs stored in the ARS can exhibit data when it is available for its secondary use. A P-XAR is stored by utilizing a PUT method issued by ODS.

(iii) Data anonymizing and publishing organization (DAP)

This organization anonymizes the original data (D-XAS) based on a publishing rule (P-XAR) and a request rule (R-XAR). A secondary use data consumer generates an R-XAR and provides it to the DAP. An R-XAR contains relevant information for D-XASs such as a URL, the requested anonymization method, its privacy level and anonymization range required to obtain the data for secondary use. The DAP receives the header of the requested D-XAS to access the link of the R-XAR. This header information does not include data. This header information is also described by using an XAR termed H-XAR; the DAP verifies its compliance

<sup>72</sup> J. -W. Byun, A. kamura, E. Bertino, N. Li; *Efficient k-anonymization using clustering techniques*; Advances in Databases: Concepts, Systems and Applications, pp. 188–200, 2007.

by checking with the R-XAR and P-XAR requested from the ARS, according to the H-XAR. In this process, a user utilizes a GET method in conjunction with the R-XAR option. If it returns a compliance error, the user receives an appropriate error message. This message utilizes the HTTP error message protocol. If no error occurs, DAP issues a GET message to obtain the D-XAS from the ODS, and issues a subsequent GET message to receive the published XAS (P-XAS) from the PDS. The PDS is described in the following paragraph (iv). The DAP generates P-XASs as anonymized data and the response from the R-XAR of the user. The user receives the anonymized data resulting from the GET method. Finally, the DAP stores the generated P-XAS issues by utilizing the PUSH method. This P-XAS is utilized to prevent further privacy leaks.

(iv) Published data storeroom organization (PDS)

This organization manages data previously published by the DAP as P-XASs. It may store all anonymized data generated by the DAP. However, to optimize data storage capacity, it is sufficient for the PDS to store only one P-XAS as anonymized data for each D-XAS, according to the one-direction anonymization policy. When generating P-XASs from D-XASs according to the requested R-XAR, it is sufficient to generate P-XASs according to the R-XAR, and store the P-XAS to the PDS. However, when generating another P-XAS from the same D-XAS according to another R-XAR, the DAP should obtain all P-XASs related to the D-XAS from the PDS. The DAP should consider all of these P-XASs when generating new P-XASs to observe P-XARs. Therefore, we propose one-directional anonymization to avoid this process. The process is as follows:

- (a) The DAP generates P-XASs according to P-XARs, instead of R-XARs, and stores it in the PDS. Therefore, the PDS stores the anonymized data, and it is anonymized according to the declared level in P-XAR. This P-XAS is not sent to the users if the requested level in the R-XAR is higher than the level in the P-XAR; this indicates the value is larger than that of the P-XAR in -anonymity.
- (b) DAP generates P-XASs according to the R-XARs. In this generation, the DAP only uses the first P-XAS generated from the P-XAR. DAP generalizes new P-XASs by adding "wild cards" as masking from the initial P-XAS. The DAP does not remove any of the "wild cards" provided as masking in the first P-XAS. Therefore, a one-directional anonymizing process should be considered.
- (c) The DAP can generate any type of P-XAS that satisfies both the R-XAR and the P-XAR by following the process described in (i) and (ii). In a scenario where -anonymity and -diversity are mixed, it is sufficient to generate a P-XAS that has a lower anonymization level than -anonymity and -diversity. For example, assume that 3-anonymity and 3-diversity are permitted in P-XARs, and 4-diversity is requested by R-XAR. In this case, DAP generates the initial P-XAR by utilizing 3-anonymity. The DAP can generate any type of P-XAR by utilizing the initial P-XAR, according to the one-directional anonymizing process.

In order to enable the data transfer between these organizations, data providers, and data consumers will utilize SSL and PKI if they transfer the data over the Internet. In the following discussions, four organizations are exhibited in order to clarify each role. It is possible to merge some of them into a single organization. Figure 8.4.2 represents an organizational structure and data connections between the organizations.

XML-based Anonymization Sheets (XAS) is a format to define the rules and data descriptions. To distinguish the rules from the data, XML-based Anonymization Rules (XAR) are also shown as a



subset of XAS. XAS and XAR differ because XAR does not contain data as contents. All transactions in this infrastructure utilize the XAS and its subset, XAR. XAS is designed according to Extensible Markup Language (XML). Figure 8.4.2 lists an example of D-XAS. It includes the information to enable anonymization, including combinations of the sensitive attribute names and quasi-identifiers, permitted anonymization methods and levels, and data attributes such as created date, updated date and history, ownership, copyrights, comments, and others. Figure 8.4.3 lists an example of a P-XAR. It does not contain raw data; it only declares the required anonymization methods and levels. To enable masking or generalization processes, it can define the delimiter for distinguishing data sections. In this example, "BirthDay" is split utilizing the '-' character. During the anonymizing process, the character is used to define the generalization boundary. If the data employs a general and standardized format, for example, BirthDay should be separated by '-' it can generalize the data entry by referring to the default rule. As an additional feature, the data provider may publish data samples without data publishing limits to publicize the data's availability. This open information is termed "open attribute." This open attribute can be declared in the data entry.

```

1 <?xml version="1.0" encoding="utf-8"?>
2 <?xml-anonymize type="text/xas" href="p-xar.xas"?>
3 <list>
4   <rdf:RDF xmlns:rdf="http://www.w3.org/1999/02/22-rdf-syntax-ns#"
   xmlns:v="http://www.w3.org/2006/vcard/ns#">
5     <v:Kind rdf:about = "http://foo.com/me/hogehoge">
6       <v:fn>Hoge Foo</v:fn>
7       <v:bday>1980-01-01</v:bday>
8       <v:hasTelephone>
9         <rdf:Description>
10          <rdf:value>+81-45-566-1454</rdf:value>
11          <rdf:type rdf:resource="http://www.w3.org/2006/vcard/ns#Work"/>
12          <rdf:type rdf:resource="http://www.w3.org/2006/vcard/ns#Voice"/>
13        </rdf:Description>
14      </v:hasTelephone>
15      <v:hasAddress>
16        <rdf:Description>
17          <v:street-address>123-45 Hoge Village</v:street-address>
18          <v:locality>FooCity</v:locality>
19          <v:postal-code>5555</v:postal-code>
20          <v:country-name>Japan</v:country-name>
21        </rdf:Description>
22      </v:hasAddress>
23    </v:Kind>
24  </rdf:RDF>
25  <OfficeScale>100ha</OfficeScale>
26  <PowerConsumption>10kWh</PowerConsumption>
27
28    <rdf:RDF xmlns:rdf="http://www.w3.org/1999/02/22-rdf-syntax-ns#"
29    xmlns:v="http://www.w3.org/2006/vcard/ns#">
30      <v:Kind rdf:about = "http://foo.com/me/db">

```

Fig. 8.4.2 D-XAS Example (Extract)

```

1 <?xml version="1.0" encoding="utf-8"?>
2 <anonymize>
3 <head>
4 <publishacceptance sensitive="divisional" quasi="divisional" />
5 <firstdatasetposition>
6 <list>
7 <rdf:RDF />
8 </list>
9 </firstdatasetposition>
10 <sensitive type="k(>=3), l(>=2)">
11 <rdf:RDF>
12 <v:Kind>
13 <v:hasTelephone>
14 <rdf:Description>
15 <rdf:type number="2" />
16 </rdf:Description>
17 </v:hasTelephone>
18 </v:Kind>
19 </rdf:RDF>
20 <PowerConsumption />
21 </sensitive>
22 <sensitive type="k(>=3), l(>=2)">
23 <OfficeScale />
24 </sensitive>
25 <group name="addr" type="quasi" level="k(>=3), l(>=3)"/>
26 </head>
27 <rdf:RDF>
28 <v:Kind>
29 <v:fn note="Full Name" />
30 <v:bday note="BirthDay" type="quasi" level="k(>=2)" sprit="-" />
31 <v:hasTelephone>
32 <rdf:Description>
33 <rdf:value note="TelephoneNumber" type="open" sprit="\s" />
34 <rdf:type note="Number Type" attribute="rdf:resource" number="2" />
35 </rdf:Description>
36 </v:hasTelephone>
37 <v:hasAddress>
38 <rdf:Description note="Addresses">
39 <v:street-address group="addr" priority="4" />
40 <v:locality group="addr" priority="3" />
41 <v:postal-code group="addr" priority="2" />
42 <v:country-name group="addr" priority="1" />
43 </rdf:Description>
44 </v:hasAddress>
45 </v:Kind>
46 </rdf:RDF>
47 <OfficeScale note="OfficeScale" />
48 <PowerConsumption type="open" note="PowerConsumption" />
49 </anonymize>

```

Fig. 8.4.3 P-XAR Example

The secondary data user can request access to the open attributes by utilizing R-XAR. Figure 8.4.4 lists an example of an R-XAR. If the secondary data consumer requests attribute identified as quasi-identifiers, DAP publishes anonymized data that contains attributes calculated as quasi-identifiers. The user also declares the required anonymization method, privacy protection level, sensitive attributes combinations, open attributes, and quasi-identifiers utilizing the R-XAR.

```

1 <?xml version="1.0" encoding="utf-8"?>
2 <anonymize type="k(3)">
3 <head>
4 <sensitive>
5 <rdf:RDF>
6 <v:Kind>
7 <v:hasTelephone>
8 <rdf:Description>
9 <rdf:type number="2" />
10 </rdf:Description>
11 </v:hasTelephone>
12 </v:Kind>
13 </rdf:RDF>
14 <PowerConsumption />
15 </sensitive>
16 <group name="addr" type="quasi" />
17 </head>
18 <rdf:RDF>
19 <v:Kind>
20 <v:bdays />
21 <v:hasTelephone>
22 <rdf:Description>
23 <rdf:value note="TelephoneNumber" type="quasi" />
24 </rdf:Description>
25 </v:hasTelephone>
26 </v:Kind>
27 </rdf:RDF>
28 <PowerConsumption note="PowerConsumption" />
29 </anonymize>

```

Fig. 8.4.4 R-XAR Example

The formats of XAS and its subset XAR utilize the cascading style sheets (CSS) format and the Semantic Web standard. The XAS can be processed utilizing an XML schema, RDL schema, OWL method, and other related tools.

## 9 Milestone

Here, we give the milestone of open data innovation in smart sustainable city mainly from the viewpoint of data management, infrastructure. In this document, each chapter has their dedicated focuses. However, several common problems and solutions potentially lie over different discussions. Considering the overlap of each chapter, the roadmap model described here is categorized into the following three groups; 1st Open data issue, 2nd Application Services in Smart Sustainable City, 3rd Security and Anonymization. All items covered in this roadmap are given in this document and are arranged into the three groups above.

Timeline:

(today-2020, 2020-2040, 2040 and beyond)

+-----> (normal scale)

+-----#-----> (with the point of technological accomplishment)

Open data issue

- Open data in smart sustainable city

Open data is the key of services in smart sustainable city.

(today-2020, 2020-2040, 2040 and beyond)

+----->

- The use of smart energy data

Energy data as open data changes grid system to smart grid, which becomes a component of smart sustainable city.

(today-2020, 2020-2040, 2040 and beyond)

+----->

- Smart transportation data

ITS and automatic driving is one of the major component of smart sustainable city.

(today-2020, 2020-2040, 2040 and beyond)

+-----#----->

- Location data

Location services is useful for every smart sustainable city services.

### Application Services in Smart Sustainable City

- Recommendation service

Recommendation services, such as concierge service, will be penetrated using data in smart sustainable city.

(today-2020, 2020-2040, 2040 and beyond)

+-----#----->

### Security and Anonymization

- Security of smart sustainable city data

(today-2020, 2020-2040, 2040 and beyond)

+-----#----->

- Anonymization of smart sustainable city data

(today-2020, 2020-2040, 2040 and beyond)

+-----#----->

## Annex A

### Application of anonymization for disaster recovery

One important application of governmental open data is disaster minimization and recovery. Disaster is a social phenomenon, such as threaten human society or economic activity brought by physical hazard and a vulnerability in the society. Disaster management is the way to eliminate the vulnerability and is depicted as Figure A.1.

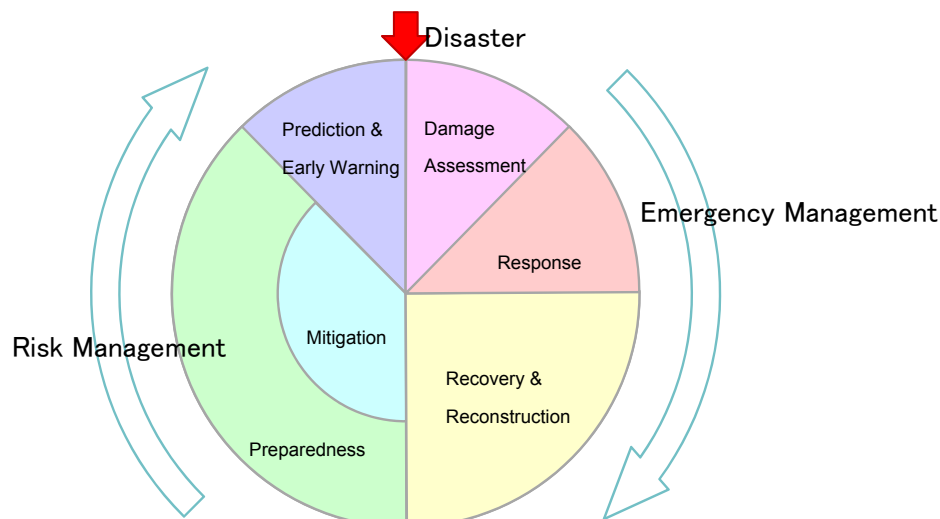


Figure A.1 – Phase of disaster recovery

#### 1) Pre-disaster: Risk Management

##### Prevention of damage

This action includes hardware approach, such as building a bank and aseismic reinforcement of building. In this case, integration with data generated by the use of structural health monitoring is indispensable. The data enables to provide applications, such as disaster prediction and early warning of disaster. The data should be published as open data to encourage these useful applications. However, this data is also a critical data from a viewpoint of privacy and security. In some cases, these data should be anonymized.

#### 2) Post-disaster: emergency management

Damage evaluation is achieved by using data of global earthquake monitoring and earth scanning from satellite or airplane. The data is used for firefighting, rescue effort and medical activity, recovery of city functions and improvement of them. Damage evaluation also reveals the weak points of the structures. From a viewpoint of privacy and security, the data of evaluation should be anonymized.

#### 3) Data acquisition

The following systems generate data and is useful for governmental open data:

- Data generated by sensors in a building with anti-shaking system like active/passive dampers
- Transportation monitoring/management system for congestion or traffic accident regulation



- Electronic health records in hospitals
- Agricultures, especially state-of-art automated environment control system in a greenhouse
- e-government including residentiary and geographical data, administrative services and social services
- Smart infrastructures, such as smart water, smart grid, smart community

These data sometimes includes privacy information of personals. From a viewpoint of privacy and security. In some cases, these data should be anonymized.

## Annex B

### Abbreviations

This Technical Report uses the following abbreviations:

ANSI	American National Standards Institute
ARS	Anonymizing Rules Storeroom organization
CA	Certificate Authority
CICH	Canadian Institutes of Health Research
CDWA	Categories for the Description of Works of Art
CHEO	Children's Hospital of Eastern Ontario
CKAN	Comprehensive Knowledge Archive Network
C/S	Client/Server
CSS	Cascading Style Sheets
DAP	Data Anonymizing and Publishing organization
DC	Dublin Core
DR	Demand Response
EAD	Encoded Archival Description
FGDC	Federal Geospatial Data Committee
FTC	Federal Trade Commissioner of United States of America
GDP	Gross Domestic Product
GILS	Government Information Locator Service
HIPAA	Health Insurance Portability and Accountability Act
HTTP	Hypertext Transfer Protocol
IoT	Internet of Things
ISO	International Organization for Standardization
ITU	International Telecommunication Union
NASA	National Aeronautics and Space Administration
NHS IC	National Health and Social Care Information Centre of United Kingdom
NILM	Non-intrusive Load Monitoring
NSERC	National Science and Engineering Research Council
ODMB	Open Data and Manpower Bureau
OECD	Economic Co-operation and Development
OED	Open Enterprise Data
ODS	Original Data Storeroom organization

OGD	Open Government Data
OID	Open Industrial Data
OMB	Office of Management and Budget
OSD	Open Scientific Data
OWL	Web Ontology Language
PARAT	Privacy Analytics Risk Assessment Tool
PHIPA	Personal Health Information Protection Act
PIP	Pseudonymization Implementation Project
PIPEDA	Personal Information Protection and Electronic Document Act
PKI	Public Key Infrastructure
PPDM	Privacy-Preserving Data Mining
PPDP	Privacy-Preserving Data Publishing
QoL	Quality of Life
RDB	Relational Databases
RDF	Resource Description Framework
RDL	Report Definition Language
REST	Representational State Transfer
RPC	Remote Procedure Call Protocol
SOAP	Simple Object Access Protocol
SSC	Smart Sustainable Cities
SSHRC	Social Sciences and Humanities Research Council
SUS	Secondary Uses Service
TEI	Text Encoding Initiative
URI	Uniform Resource Identifier
VRA	Visual Resources Association
XAS	XML-based Anonymization Sheets
XAR	XML-based Anonymization Rules
XML	Extensible Markup Language

## Appendix I

### Bibliography

- [b-FG-SSC overview] FG-SSC deliverable (2014), Technical Report on an overview of smart sustainable cities and the role of information and communication technologies.
- [b-FG-SSC KPIsICT] FG-SSC deliverable, Key performance indicators related to the use of information and communication technology in smart sustainable cities.
- [b-FG-SSC infrastructure] FG-SSC deliverable, Smart Sustainable Cities Infrastructure.
- [b-FG-SSC security] FG-SSC deliverable, Technical Report on cyber-security, data protection and cyber-resilience in smart sustainable Cities.
- [b-FG-SSC management] FG-SSC deliverable, Technical Report on integrated management for smart sustainable cities.
- [b-FG-SSC KPIs metrics] FG-SSC deliverable, Technical Report on metrics and evaluation of key performance indicators for smart sustainable cities.
- Accenture | Strategy. Understanding Data Visualization. 2013
- A. Machanavajjhala, D.Kifer, J. Gehrke, et al., *L-diversity: Privacy beyond k-anonymity*, ACM Transactions on Knowledge Discovery from Data (TKDD), Vol. 1, No. 1, 2007.
- B. P. Allen and J. T. Tennis, *Building metadata-based navigation using semantic Web standards: the Dublin Core 2003*, Conference Proceedings 2004 Proceedings of the 2004 Joint ACM/IEEE Conference on. 2004.
- B. C. Chen, D. Kifer, K. LeFevre, A. Machanavajjhala, *Privacy-Preserving Data Publishing*, Foundations and Trends in Databases, Vol. 2, No. 1-2, pp. 1-167, 2009.
- Committee on Scientific Accomplishments of Earth Observations from Space, National Research Council (2008). Earth Observations from Space: The First 50 Years of Scientific Achievements.
- The National Academies Press. p. 6. ISBN 0-309-11095-5. Retrieved 2010-11-24.
- C. M. F. Benjamin, K. Wang, R. Chen, et al., *Privacy-preserving data publishing: A survey of recent developments*, ACM Computing Surveys (CSUR), Vol. 42, No. 4, 2010.
- Data.gov.uk, URL: <http://data.gov.uk/about> (2014).
- Declaration to be the World's Most Advanced IT Nation, URL: [http://japan.kantei.go.jp/policy/it/20140624\\_declaration.pdf](http://japan.kantei.go.jp/policy/it/20140624_declaration.pdf) (2014).
- Digital Government: Building a 21st Century Platform to Better Serve the American People, URL <http://www.whitehouse.gov/sites/default/files/omb/egov/digital-government/digital-government.html> (2014).
- D. Li, L. Timothy, S. E. John, et al., *TWC LOGD: A portal for linked open government data ecosystems*, Web Semantics: Science, Services and Agents on the World Wide Web 9 (2011) 325–333.
- D. S. Raghuvanshi, M. R. Rajagopalan, *MS2: Practical data privacy and security framework for data at rest in cloud*. Computer Applications and Information Systems (WCCAIS), 2014 World Congress on. 2014, Page(s): 1- 8.
- GoodGuide, [www.goodguide.com](http://www.goodguide.com) (2014).

- Health Data Initiative, HelthData.gov, URL: <http://healthdata.gov/> (2014).
- H. M. Yu, *Designing Software to Shape Open Government Policy*, Princeton University, 2012.
- H. Nishi, K. Inoue, et al., *IEEE SMART GRID VISION FOR VEHICULAR TECHNOLOGY: 2030 AND BEYOND*, IEEE Standards Association, pp. 41-42, Jan., 2014.
- <https://technet.microsoft.com/en-us/library/dd277323.aspx>.
- <http://datasecuritymanagement.com/>.
- <http://en.factolex.com/metadata>.
- <http://research.cs.wisc.edu/wind/Publications/zfs-corruption-fast10.pdf>.
- <http://www.math.yorku.ca/SCS/Gallery/milestone/milestone.pdf>.
- <http://linkeddata.org/faq>.
- <http://www.niso.org/publications/press/UnderstandingMetadata.pdf>.
- <http://lists.w3.org/Archives/Public/semantic-web/2011Oct/0041.html>.
- [http://opendatachina.com/the-business-case-for-open-data/\(2014\)](http://opendatachina.com/the-business-case-for-open-data/(2014)).
- <https://technet.microsoft.com/en-us/library/dd277323.aspx>.
- <http://techpresident.com/news/wegov/24940/China-Open-Data-Movement-Starting-Take-Off>.
- <http://www.accenture.com/SiteCollectionDocuments/PDF/Accenture-Tech-Labs-Data-Visualization-Full-Paper.pdf>.
- <http://www.emprata.com/what-we-do/data-visualization/>.
- <http://www.nyc.gov/html/dcp/html/about/pr031411.shtml>.
- <http://www.nyc.gov/html/dcp/html/cwp/index.shtml>.
- <http://www.spamlaws.com/data-security.html>.
- IT dash board, National Strategy Office of Information and Communications Technology, URL: <http://www.itdashboard.go.jp/> (2014).
- J. Gurin, *Open Data Now: The Secret to Hot Startups, Smart Investing, Savvy Marketing, and Fast Innovation*, McGraw-Hill Professional.
- J. Mize, R.T. Habermann, *Automating metadata for dynamic dataset*, OCEANS 2010. 2010, Page(s): 1-6.
- J. W. Byun, A. kamura, E. Bertino, et al., *Efficient k-anonymization using clustering techniques*, *Advances in Databases: Concepts, Systems and Applications*, pp. 188–200, 2007.
- Kawasaki City Open Data, Kawasaki City Office, URL: <http://citydata.jp/%E7%A5%9E%E5%A5%88%E5%B7%9D%E7%9C%8C/%E5%B7%9D%E5%B4%8E%E5%B8%82> (2014).
- K. Okada and H. Nishi, *Big Data Anonymization Method for Demand Response Services*, ICOMP'14, The 2014 International Conference on Internet Computing and Big Data, 2014.
- L. M. Prieto, A. C. Rodríguez, J. Pimiento, *Implementation Framework for Open Data in Colombia*, ICEGOV '12, October 22-25 2012.
- L. N. Mutuku and J. Colaco, *Increasing Kenyan Open Data Consumption: A Design Thinking Approach*, ICEGOV '12, October 22 - 25 2012, Albany, NY, USA.

- L. Richardson, Mike A, RESTful web APIs. 2013.
- L. Seeney, *k-anonymity: A model for protecting privacy*, International Journal on Uncertainty, Fuzziness and Knowledge-based Systems, vol. 10, no. 5, pp. 557–570, 2002.
- L. Yang, X. Chen, J. Zhang, et al., *Optimal Privacy-Preserving Energy Management for Smart Meters*, IEEE INFOCOM 2014, Page(s): 513-521.
- L. Zhu, R.D. Kent, A. Aggarwal, et al., *Construction of a Webportal and User Management Framework for Grid*, High Performance Computing Systems and Applications, HPCS 2007, 21st International Symposium on. 2007, Page(s): 14.
- M. Franck, M. Johan and F. Catherin, *A survey of RDB to RDF translation approaches and tools*. NISO Press, National Information Standards Organization, Understanding Metadata.
- N. Shadbolt, K. O'Hara, T. Berners-Lee, et al., *Linked Open Government Data: Lessons from Data.gov.uk*, IEEE INTELLIGENT SYSTEMS, May-June 2012, 16-24 (Volume: 27, Issue: 3).
- OECD Declaration on Open Access to publicly funded data.
- OECD Principles and Guidelines for Access to Research Data from Public Funding.
- Open Data 500, [www.opendata500.com](http://www.opendata500.com) (2014).
- Open Data for Development Challenge, Foreign Affairs, Trade and Development Canada, URL: <http://www.acdi-cida.gc.ca/acdi-cida/acdi-cida.nsf/eng/DEN-1223131242-PCZ> (2014).
- Open Definition, URL: <http://opendefinition.org/od/#sthash.PmqzibQW.dpuf> (2014).
- Opower Official Website, URL: <http://opower.com/> (2014).
- Q. Xiao, W. Yan, H. Zhang, *Application of Visualization Technology in Spatial Data Mining. Computing, Control and Industrial Engineering (CCIE)*, 2010 International Conference on. 2010, Page(s): 153-157.
- R. Agrawal, R. Srikant, *Privacy-preserving data mining*, SIG-MOD, Vol. 29, pp. 439-450, 2000.
- R. Irfan, G. Bickler, S. U. Khan, et al., *Survey on social networking services*, IET Networks, 2013, Page(s): 224-234.
- S. McLaughlin, P. McDaniel, W. Aiello, *Protecting consumer privacy from electric load monitoring*, in Proceedings of the 18th ACM conference on Computer and communications security CCS '11, 2011.
- Stephen B.P, Mehra. A , Daniel J, Giuseppe. L . Network Analysis in the Social Sciences". Science 323. 2009
- S. Turchi, F. Paganelli, L. Bianchi, et al., *A lightweight linked data implementation for modeling the Web of Things*, Pervasive Computing and Communications Workshops (PERCOM Workshops), 2014 IEEE International Conference on 2014, Page(s): 123-128.
- T. B. Lee, *Linked Data*, 2011-05-15, <http://www.w3.org/DesignIssues/LinkedData.html>.
- T. Hattori, N. Toda, *Demand response programs for residential customers in the United States—Evaluation of the pilot programs and the issues in practice*, MARCH 2011.
- T. Heath and C. Bizer, *Linked Data: Evolving the Web into a Global Data Space* Heath, 2011.
- World Data Center System (2009-09-18). "About the World Data Center System". NOAA, National Geophysical Data Center. Retrieved 2010-11-24.



W. David, Z. Marsha, R. Luke, et al., *Linked Data: Structured Data on the Web*.

W. Parks, *Open Government Principle: Applying the Right to Know Under the Constitution*. The George Washington Law Review. 26, 1 (1957), 1-22.

Y. Lindell, B. Pinkas, *Privacy Preserving Data Mining*, Journal of Cryptology, Vol. 15, pp. 177-206, 2002.

Y. Nakamura, K. Matsui and H. Nishi, *Anonymization Infrastructure for Secondary Use of Data*, ICOMP'14 - The 2014 International Conference on Internet Computing and Big Data, 2014.

Y. Yu, J. Ni, M. H. Au, et al., *On the Security of a Public Auditing Mechanism for Shared Cloud Data Service*, Services Computing, IEEE Transactions on. 2014, Page(s): 1.







# Metrics for Measuring Smart Sustainable City Transitions

# 4









# 4.1

## Overview of key performance indicators in smart sustainable cities



## Acknowledgements

This Technical Specifications was researched and principally authored by Ziqin Sang (Fiberhome Technologies Group). The author would like to thank ITU for providing the opportunity to work and research under the ITU-T Focus Group on Smart Sustainable Cities (FG-SSC). The author would also like to recognize the contributions of Pernilla Bergmark (Ericsson), Claudio di Carlo (Italy), Ramy Ahmed Fathy (NTRA, Egypt), Jia Guo (Fiberhome Technologies Group), Takafumi Hashitani (Fujitsu), Junnosuke Sugiura (Fujitsu), Angelica V Ospina (University of Manchester) and Mythili Menon (University of Geneva) who provided inputs for this Technical Specifications.

The author also acknowledges the guidance and support from all the members of the ITU-T FG-SSC Management Team.

Additional information and materials relating to this Technical Specifications can be found at: [www.itu.int/itu-t/climatechange](http://www.itu.int/itu-t/climatechange). If you would like to provide any additional information, please contact Cristina Bueti (ITU) at [tsbgs5@itu.int](mailto:tsbgs5@itu.int).

## Table of Contents

		Page
<b>1</b>	<b>Scope.....</b>	<b>760</b>
<b>2</b>	<b>References.....</b>	<b>760</b>
<b>3</b>	<b>Definitions.....</b>	<b>761</b>
	3.1 Terms defined elsewhere.....	761
	3.2 Terms defined in these Technical Specifications .....	761
<b>4</b>	<b>Abbreviations and acronyms .....</b>	<b>761</b>
<b>5</b>	<b>Overview of key performance indicators (KPIs) in a city context.....</b>	<b>762</b>
<b>6</b>	<b>Key performance indicators.....</b>	<b>762</b>
	6.1 Dimensions of KPIs .....	762
	6.2 Sub-dimensions of KPIs .....	763
	6.3 Description of dimensions and sub-dimensions of KPIs .....	765





## Overview of key performance indicators in smart sustainable cities

### Summary

The Technical Specifications listed in section 2 give a general guidance to cities and provide an overview of key performance indicators (KPIs) in the context of smart sustainable cities.

These Technical Specifications are expected to become an ITU-T Recommendation.

### Keywords

Cities, information communication technologies (ICTs), key performance indicators (KPIs), metrics and evaluation, smart sustainable cities (SSCs), sustainability impacts.

### Introduction

According to the terms of reference (ToR) of the Focus Group on Smart Sustainable Cities (FG-SSC), one of the objectives is to:

- Identify or develop a set of key performance indicators (KPIs) to assess how the use of ICTs has an impact on the environmental<sup>1</sup> sustainability of cities.

One of the specific tasks of FG-SSC is to:

- Develop a document which contains a set of KPIs to assess the impact of the use of ICT projects in cities.

These Technical Specifications are one of the deliverables developed by FG-SSC which defines KPIs. The series of KPI definitions deliverables also include:

- Technical Specifications on key performance indicators (KPIs) related to the use of information and communication technology (ICT) in smart sustainable cities [ITU-T L.KPIs-ICT]. This document lists the KPIs focusing on ICT usage in SSCs.
- Technical Specifications on key performance indicators (KPIs) related to the sustainability impacts of information and communication technology (ICT) in smart sustainable cities [ITU-T L.KPIs-impact]. This document lists the KPIs proposed for ICT impact on sustainability.
- Technical Report on Supplement on key performance indicators (KPIs) for smart sustainable cities [ITU-T L.KPIs-Sup.]. This document provides information regarding KPIs and evaluation index systems of smart cities, KPIs of sustainable cities, etc.

---

<sup>1</sup> The terms of reference for FG-SSC particularly mentions environmental sustainability. However, this document tries to have a broader perspective and embraces also indicators that are related to quality of life, social and economic aspects.

## 1 Scope

The Technical Specifications listed in section 2 outline the key performance indicators (KPIs) in the context of smart sustainable cities (SSC). Evaluating these indicators can help cities as well as their stakeholders understand to what extent they may be perceived as smart sustainable cities (SSCs).

The Technical Specifications can be utilized by:

- Cities and municipal administrations, including the SSC-relevant policy-making organizations, and government sectors, enabling them to develop strategies and understand the progress related to the use of ICT for making cities smarter and more sustainable.
- City residents and non-profit citizen organizations, enabling them to understand the development and progress of SSCs with respect to ICT's impact.
- Development and operation organizations of SSC, including planning units, SSC-related producers and service providers, operation and maintenance organizations, helping them to fulfil the tasks of sharing information related to the use of ICT and its impact on the sustainability of cities.
- Evaluation and ranking agencies, including academia and 3rd party ranking agencies, supporting them in the selection of relevant KPIs for assessing the contribution from ICTs in the development of SSCs.

The intention of KPIs is to publish the criteria to evaluate ICT's contributions in making cities smarter and more sustainable. It is desirable that each city can quantify continuously an achievement degree according to their goal following KPIs.

## 2 References

[ITU-T L.KPIs-ICT]	<i>Technical specification on key performance indicators (KPIs) related to the level and usage of information and communication technology (ICT) in smart sustainable cities.</i>
[ITU-T L.KPIs-impact]	<i>Technical specification on key performance indicators (KPIs) related to the sustainability impacts of information and communication technology (ICT) in smart sustainable cities.</i>
[ITU-T L.KPIs-Sup.]	<i>Technical report on supplement on key performance indicators (KPIs) definitions for smart sustainable cities.</i>
[ITU-T TR SSC Def.]	<i>Technical report on definitions and attributes of a smart sustainable city.</i>
[UN-Habitat report]	<i>UN-Habitat report, State of the World's cities 2012/2013 Prosperity of Cities.</i>
[ISO 37120]	<i>ISO 37120:2014, Sustainable development of communities – Indicators for city services and quality of life.</i>

### 3 Definitions

#### 3.1 Terms defined elsewhere

**3.1.1 smart sustainable cities:** A smart sustainable city is an innovative city that uses information and communication technologies (ICTs) and other means to improve quality of life, efficiency of urban operation and services, and competitiveness, while ensuring that it meets the needs of present and future generations with respect to economic, social, environmental as well as cultural aspects.

#### 3.2 Terms defined in these Technical Specifications

These Technical Specifications define the following terms:

**3.2.1 City:** An urban geographical area with one (or several) local government and planning authorities.

**3.2.2 City sustainability:** The sustainability of a smart city is based on four main aspects:

- Economic: The ability to generate income and employment for the livelihood of the inhabitants.
- Social: The ability to ensure that the well-being (safety, health, education) of the citizens can be equally delivered despite differences in class, race or gender.
- Environmental: The ability to protect future quality and reproducibility of natural resources.
- Governance: The ability to maintain social conditions of stability, democracy, participation, and justice.

### 4 Abbreviations and acronyms

These Technical Specifications use the following abbreviations and acronyms:

GHG	Greenhouse Gas
ICT	Information and Communication Technology
IDI	ICT Development Index
ISO	International Organization for Standardization
KPI	Key Performance Indicator
OSI	Open Systems Interconnection
PM10	Particulate Matter up to 10 micrometres in size
SSC	Smart Sustainable Cities
ToR	Terms of Reference
UN-Habitat	United Nations Human Settlements Programme



## 5 Overview of key performance indicators (KPIs) in a city context

KPIs of SSC consist of two series of deliverables: KPI definitions and KPI metrics and evaluation.

The series of KPI definitions deliverables include:

- Technical specifications on key performance indicators (KPIs) related to the use of information and communication technology (ICT) in smart sustainable cities [ITU-T L.KPIs-ICT]. This document lists the KPIs focusing on ICT usage in SSCs.
- Technical specifications on key performance indicators (KPIs) related to the sustainability impacts of information and communication technology (ICT) in smart sustainable cities [ITU-T L.KPIs-impact]. This document lists the KPIs proposed for ICT impact on sustainability.
- Technical report on Supplement on key performance indicators (KPIs) for smart sustainable cities [ITU-T L.KPIs-Sup.]. This document provides information regarding KPIs and evaluation index systems of smart cities, KPIs of sustainable cities, etc.

The Technical Specifications, under development within the Focus Group on Smart Sustainable Cities (FG-SSC), are expected to cover the examples of metrics and examples of evaluation of indicators of [ITU-T L.KPIs-ICT] and [ITU-T L.KPIs-impact], and are expected to become ITU-T Recommendations.

## 6 Key performance indicators

### 6.1 Dimensions of KPIs

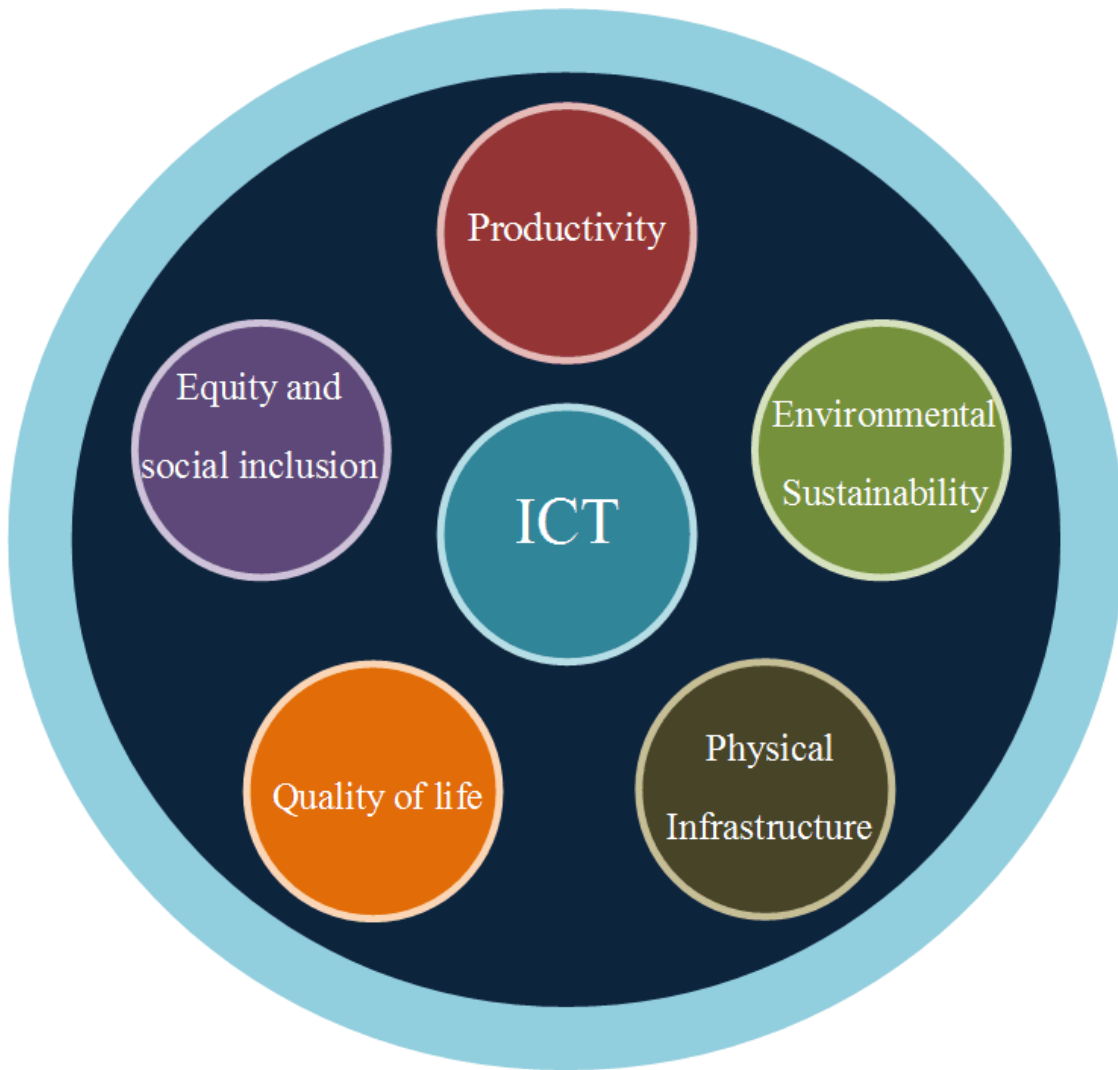
Technical Specifications on KPIs take into consideration the definition of SSC from ITU-T FG-SSC [ITU-T TR SSC Def.], the City Prosperity Index of UN-Habitat [UN-Habitat report], and [ISO 37120]. The proposed set of KPIs focuses specifically on a set of ICT-related indicators for smart sustainable cities and does not cover all KPIs of cities contained in [ISO 37120].

The dimensions of KPIs can be categorized as shown in Figure 1:

- Information and Communication Technology<sup>2</sup>
- Environmental sustainability
- Productivity
- Quality of life
- Equity and social inclusion
- Physical infrastructure.

---

<sup>2</sup> In the UN-Habitat prosperity index, ICT forms part of the general 'Infrastructure' category. In the FG-SSC structure, ICT is defined as a separate category to highlight the focus of ITU.



**Figure 1 – Dimensions of KPIs for SSCs**

**6.2 Sub-dimensions of KPIs**

The sub-dimensions for each dimension are recorded in Table 1 and explained in the succeeding subsections.

In Table 1 each dimension is identified by the letter Dx. The sub-dimensions are then classified by the label Dx.y where x maps to dimension and y maps to sub-dimension.

**Table 1 – Sub-dimensions of KPIs**

Dimension #	Dimension	Sub-dimension #	Sub-dimension
D1	Information and communication technology	D1.1	Network and access
		D1.2	Services and information platforms
		D1.3	Information security and privacy
		D1.4	Electromagnetic field
D2	Environmental sustainability	D2.1	Air quality
		D2.2	CO <sub>2</sub> emissions
		D2.3	Energy

Dimension #	Dimension	Sub-dimension #	Sub-dimension
		D2.4	Indoor pollution
		D2.5	Water, soil and noise
D3	Productivity	D3.1	Capital investment
		D3.2	Employment
		D3.3	Inflation
		D3.4	Trade
		D3.5	Savings
		D3.6	Export/import
		D3.7	Household income/consumption
		D3.8	Innovation
		D3.9	Knowledge economy
		D4	Quality of life
D4.2	Health		
D4.3	Safety/security public place		
D4.4	Convenience and comfort		
D5	Equity and social inclusion	D5.1	Inequity of income/consumption (Gini coefficient)
		D5.2	Social and gender inequity of access to services and infrastructure
		D5.3	Openness and public participation
		D5.4	Governance
D6	Physical infrastructure	D6.1	Infrastructure/connection to services – piped water
		D6.2	Infrastructure/connection to services – sewage
		D6.3	Infrastructure/connection to services – electricity
		D6.4	Infrastructure/connection to services – waste management
		D6.5	Connection to services – knowledge infrastructure
		D6.6	Infrastructure/connection to services – health infrastructure
		D6.7	Infrastructure/connection to services – transport
		D6.8	Infrastructure/connection to services – road infrastructure
		D6.9	Housing – building materials
		D6.10	Housing – living space
		D6.11	Building

## 6.3 Description of dimensions and sub-dimensions of KPIs

### 6.3.1 D1 ICT

D1 concentrates on ICT infrastructure, which is the basis for other ICT solutions and smart sustainable promotions. The ICT infrastructure includes network and access (D1.1), services and information platforms (D1.2), information security and privacy (D1.3), and Electromagnetic field (D1.4).

#### D1.1 Network and access

Network and access refers to the network layer in the Open Systems Interconnection (OSI) model, especially backbone and access networks, including optical broadband, wireless broadband and broadcasting network.

#### D1.2 Services and information platforms

Services and information platforms refers to ICT services and equipment above the network layer, including software services and private handsets.

#### D1.3 Information security and privacy

Information security and privacy refers to the security parts including privacy protection.

#### D1.4 Electromagnetic field

Application of exposure guidelines, consistent planning approval process and information for public should be considered with respect to Electromagnetic fields.

### 6.3.2 D2 Environmental sustainability

D2 examines the ICT usage and impact on key environmental areas. It is classified into five categories: air quality (D2.1), CO<sub>2</sub> emissions (D2.2), energy (D2.3), indoor pollution (D2.4), and water, soil and noise (D2.5).

#### D2.1 Air quality

This part looks into the quality of air which is an important area for consideration for many cities.

#### D2.2 CO<sub>2</sub> emissions

This part looks into the CO<sub>2</sub>-e emissions of the city where “-e” is “equivalent” and every other greenhouse gases are converted into CO<sub>2</sub>.

#### D2.3 Energy

This part looks into the energy use of the city.

#### D2.4 Indoor pollution

This part is about indoor environment.

#### D2.5 Water, soil and noise

This part collects elements such as water quality and noise.

### 6.3.3 D3 Productivity

The ICT impact on D3 Productivity would be evaluated in nine categories: capital investment (D3.1), formal/informal employment (D3.2), inflation (D3.3), trade (D3.4), savings (D3.5), export/import (D3.6), household income/consumption (D3.7), innovation (D3.8), and economic sustainability (D3.9). Economy is the driving engine of human society. Therefore, it is necessary to investigate whether or not SSC helps to prime the pump of the local economy. Meanwhile, innovation weighs increasingly in the economy. As high tech plays a pivotal role in SSC, it is valuable to find out the local competence of innovation.

#### D3.1 Capital investment

This part is about the capital investment when building SSC.

#### D3.2 Employment

This part is about the formal or informal employment in a city.

#### D3.3 Inflation

The indicator of inflation reflects the currency devaluation and price rise.

#### D3.4 Trade

This part is about the e-commerce transaction in SSC.

#### D3.5 Savings

This part is about the average household savings in SSC.

#### D3.6 Export/import

This part is about the export/import at the city level.

#### D3.7 Household income/consumption

This part is about the average household income/consumption in SSC.

#### D3.8 Innovation

This part assesses the city's ability of innovation through multiple perspectives. It would indicate whether it is an innovation city or innovative city. Innovative city refers to cities that can adjust to changes quickly and play as a regional lead.

#### D3.9 Knowledge economy

This part studies whether or not SSC is pumping the economy. Because of the fast growth and drastic changes of technology innovation as well as its close effect on the economy, industry, science and society, economic sustainability must face challenges from all these impacts.

### 6.3.4 D4 Quality of life

The ICT impact on D4 Quality of life in SSC would be sampled mainly in the following four sectors: education (D4.1), health (D4.2), safety/security public place (D4.3), convenience and comfort (D4.4). D4 will find out if ICT is helping people get a better life.

#### **D4.1 Education**

Education and training is critical to enhance human creativity and social quality. This section examines how ICT modernizes education and training.

#### **D4.2 Health**

Health care here refers specifically to medical services. Citizens are complaining more and more about limited medical resources and skewed supply and demand relationship. This part investigates how ICT contributes to solve this problem.

#### **D4.3 Safety/security public places**

Security and safety is the basic civil service guaranteed by governors since ancient times. Security concerns are mainly about man-made threats, specifically crimes and terrorism. Safety is about actions taken against natural disasters and accidents. ICT plays a vital role in these two areas.

#### **D4.4 Convenience and comfort**

This part is a complementary set of other objective research. It contains subjective feelings and impressions regarding various topics mentioned above as a result of questionnaires and interviews.

#### **6.3.5 D5 Equity and social inclusion**

The ICT impact on D5 Equity and social inclusion in SSC would be sampled in the following four sectors: inequity of income/consumption (D5.1), social and gender inequity of access to services and infrastructure (D5.2), openness and public participation (D5.3), and governance (D5.4). Governance and public service have a great influence on social development. It is obvious that modern governments must be open and highly efficient. Otherwise, frequent turbulence would jeopardize stability and development. D5 will find out if ICT is helping improve social harmony and administrative efficiency.

##### **D5.1 Inequity of income/consumption**

This part is about the inequity of income/consumption at the city level.

##### **D5.2 Social and gender inequity of access to services and infrastructure**

This part is about the social and gender inequity of access to services and infrastructure at the city level.

##### **D5.3 Openness and public participation**

Domestically, more and more people come to live in cities as a result of urbanization. Hence, it is important to help those citizens adapt easily to their new environment. In the background of globalization, every city is trying to attract tourists, talents and investment worldwide and there are multi-ethnic and multi-religion issues involved in this process. This part tries to discover how ICT could improve the openness of the city and its citizens.

Moreover, this part studies how ICT elevates people's willingness of participation. The citizenship spirit is reflected directly in the participation in public life.



A sustainable society should have a manageable wealth gap, and an open channel for citizens. It should be appealing, free and have a democratic environment for people to discuss and co-operate. This section checks if ICT is helping to increase social coherence and citizenship consciousness.

#### **D5.4 Governance**

This part investigates ICT applications in various administrative affairs and checks if they are helping to improve anti-corruption as well as government openness and efficiency.

#### **6.3.6 D6 Physical infrastructure**

The ICT impact on D6 Physical infrastructure would be evaluated in 11 categories: infrastructure/connection to services – piped water (D6.1), infrastructure/connection to services – sewage (D6.2), infrastructure/connection to services – electricity (D6.3), infrastructure/connection to services – waste management (D6.4), infrastructure/connection to services – knowledge infrastructure (D6.5), infrastructure/connection to services – health infrastructure (D6.6), infrastructure/connection to services – transport (D6.7), infrastructure/connection to services – road infrastructure (D6.8), housing – building materials (D6.9), housing – living space (D6.10), and building (D6.11). This part would focus on the improvement of the important municipal infrastructures.

##### **D6.1 Infrastructure/connection to services – piped water**

Municipal pipe networks, such as water, electricity, gas, and heating pipes, etc., stretch out to every corner of the city. There are various kinds of pipe networks which play an important role in the functioning of the city. These systems are colossal, complex and arduous to maintain. Moreover, they are not risk free, some even has a potentially fatal danger like the gas pipe network. Therefore, there is an urge for smart cities to upgrade their municipal pipe network maintenance with modern smart technologies.

##### **D6.2 Infrastructure/connection to services – sewage**

Sanitation is an important public service to prevent diseases from spreading. This part is mainly concerned with ICT's impact on (CDC), sewage systems as well as garbage disposal and recycling.

##### **D6.3 Infrastructure/connection to services – electricity**

This part is about the infrastructure of electricity at the city level.

##### **D6.4 Infrastructure/connection to services – waste management**

This part is about the infrastructure of waste management at the city level.

##### **D6.5 Connection to services – knowledge infrastructure**

This part is about the knowledge infrastructure such as education, and culture at the city level.

##### **D6.6 Infrastructure/connection to services – health infrastructure**

This part is about the infrastructure of health care at the city level.

### **D6.7 Infrastructure/connection to services – transport**

Transport is the hottest focus of civil services. Traffic jams have been a worldwide headache costing tremendous energy and expenses. This part investigates how ICT measures counter various negative transport effects.

### **D6.8 Infrastructure/connection to services – road infrastructure**

This part is about the infrastructure such as roads, streets, lighting system at the city level.

### **D6.9 Housing – building materials**

This part is about the building materials in SSC.

### **D6.10 Housing – living space**

This part is about the average living space in SSC.

### **D6.11 Building**

Most human activities take place inside buildings. Buildings are an everlasting symbol of urbanism and they grow hand in hand with the progress of urbanization. In this new era of smart sustainable cities, buildings are supposed to provide cosiness, convenience, resilience and energy efficiency beyond inhabitation and beauty. This part checks how ICT meets these goals.

OBJECTIVE



MEASUREMENT

# KPI

KEY PERFORMAN  
INDICATOR



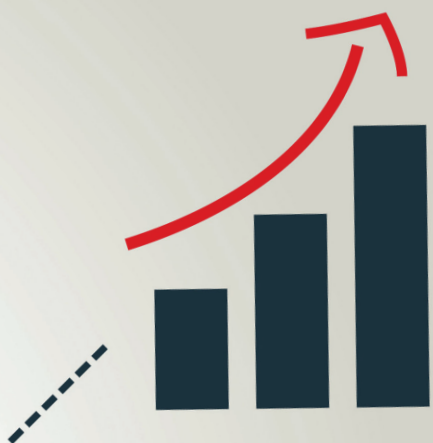
SUCCESS



EVALUATION

PERFO

OPTIMIZATION



ICE



STRATEGY



PERFORMANCE

## 4.2

Key performance indicators related to the use of information and communication technology in smart sustainable cities

Technical Specifications

## Acknowledgements

These Technical Specifications were researched and authored by Ziqin Sang (Fiberhome Technologies Group), Hongqing Ding (Fiberhome Technologies Group), Masayuki Higashi (Japan), Jiro Nakamura (NTT), Minako Hara (NTT), Takafumi Hashitani (Fujitsu), Junnosuke Sugiura (Fujitsu), Claudio Di Carlo (Italy), Paola Girdinio (Genoa University), Raffaele Bolla (Genoa University), Paolo Gemma (Huawei), Dewei Xu (Fiberhome Technologies Group), Jia Guo (Fiberhome Technologies Group), Pernilla Bergmark (Ericsson), Lelio Digeronimo (Avina), Luis Castiella (San Andrés University), Mike Wood (Telstra), Jack Rowley (GSMA), Christer Tornevik (Ericsson) and Christophe Grangeat (Alcatel-Lucent) .

The authors wish to extend their gratitude to Ramy Ahmed Fathy (NTRA, Egypt), Michael Mulquin (IS Communications), Angelica V. Ospina (University of Manchester), Mythili Menon (University of Geneva) for their valuable inputs and support.

The authors acknowledge the guidance and support from all the members of the ITU-T Focus Group on Smart Sustainable Cities (FG-SSC) Management Team.

Additional information and materials relating to this Technical Specifications can be found at: [www.itu.int/itu-t/climatechange](http://www.itu.int/itu-t/climatechange). If you would like to provide any additional information, please contact Cristina Bueti (ITU) at [tsbsg5@itu.int](mailto:tsbsg5@itu.int).

## Table of Contents

		Page
<b>1</b>	<b>Scope.....</b>	<b>776</b>
<b>2</b>	<b>References.....</b>	<b>776</b>
<b>3</b>	<b>Definitions.....</b>	<b>777</b>
	3.1 Terms defined elsewhere .....	777
	3.2 Terms defined in these Technical Specifications .....	777
<b>4</b>	<b>Abbreviations and acronyms .....</b>	<b>778</b>
<b>5</b>	<b>General principles for Key Performance Indicators (KPIs) for ICT in a city context ..</b>	<b>778</b>
<b>6</b>	<b>Key Performance Indicators.....</b>	<b>779</b>
	6.1 Sub-dimensions of KPIs .....	779
	6.2 Key performance indicators of SSC .....	780
	<b>Appendix I – Additional indicators .....</b>	<b>788</b>
	<b>Appendix II – UN habitat City Prosperity Index.....</b>	<b>791</b>
	<b>Bibliography .....</b>	<b>793</b>





## Key performance indicators related to the use of information and communication technology in smart sustainable cities

### Executive summary

These Technical Specifications give general guidance to cities and provides for the definitions of key performance indicators (KPIs) related to the use of information and communication technology (ICT) in the context of Smart Sustainable Cities (SSCs).

These Technical Specifications are expected to become an ITU-T Recommendation and the focus will be on the application of the ICT. Other Technical Specifications, under development within the Focus Group on Smart Sustainable Cities (FG-SSC), cover the definitions of KPIs related to the sustainability impacts of ICT and are expected to become another ITU-T Recommendation.

### Keywords

Information and Communication Technologies (ICTs), Smart Sustainable Cities (SSC), Sustainability Impacts, Cities

### Introduction

According to the terms of reference (ToR) of the Focus Group on Smart Sustainable Cities (FG-SSC), one of the objectives is to:

- Identify or develop a set of key performance indicators (KPIs) to assess how the use of ICTs has an impact on the environmental<sup>1</sup> sustainability of cities.
- One of the specific tasks and deliverables of the FG-SSC is to:
  - Develop a document of KPIs to assess the impact of the use of ICT projects in cities.

This document is one of the deliverables developed by the FG-SSC and defines the KPIs. The series of KPIs definitions deliverables include:

- Technical Specifications on overview of key performance indicators in smart sustainable cities [ITU-T L.KPIs-overview].
- Technical Specifications on key performance indicators related to the use of information and communication technology in smart sustainable cities. This document lists the KPIs focusing on ICT use in SSC.
- Technical Specifications on key performance indicators related to the sustainability impacts of information and communication technology in smart sustainable cities [ITU-T L.KPIs-impact]. This document lists the KPIs proposed for ICT impact on sustainability.
- Technical Report on key performance indicators definitions for Smart Sustainable Cities [ITU-T L.KPIs-Supp]. This document provides the information regarding existing KPIs and evaluation index systems for smart cities, KPIs for sustainable cities, etc.

In this document FG-SSC proposes ICT related KPIs in alignment with the definition of SSC while considering the dimensions of such a city. This document is aligned with the framework provided by UN Habitat in its City Prosperity Index with respect to the categorization of indicators as described in Appendix II and further detailed in [ITU-T L.KPIs-overview].

---

<sup>1</sup> The terms of reference of FG-SSC particularly mention environmental sustainability. However, this document tries to have a broader perspective and embraces also indicators that are related to quality of life, social and economic aspects.

## 1 Scope

---

These technical specifications form part of a series of Technical Reports and Technical Specifications focusing on the key performance indicators (KPIs) for smart sustainable cities (SSCs). It specifically provides the KPIs related to ICT adoption and use in the context of SSC. Evaluating these indicators can help cities as well as their stakeholders understand the extent to which they may be perceived as SSC. These Technical Specifications describe applicability of KPIs, principles and dimensions as well as the definitions of corresponding indicators. To fit into the overall framework of city indicators the present Technical Specifications re-use the categorization of UN Habitat's City Prosperity Index.

These Technical Specifications can be utilized by:

- Cities and municipal administrations, including the SSC-relevant policy-making organizations, and government sectors, enabling them to develop strategies and understand the progress related to the use of ICT for making cities smarter and more sustainable.
- City inhabitants and their non-profit organizations, enabling them to understand the development and progress of SSC.
- Development and operation organizations of SSC, including planning unit, SSC-related producers and service providers, operation and maintenance organizations, helping them to fulfill the tasks of sharing information related to the use of ICT in the city.
- Evaluation agencies and academia, supporting them in selection of relevant KPIs for assessing the contribution from ICT in the development of SSC.

The intention of identifying the KPIs is to establish the criteria to evaluate ICT's contributions in making cities smarter and more sustainable, and to provide the cities with the means for self-assessments. It is desirable that cities can quantify their achievement according to their goals.

These Technical Specifications list the core indicators that are chosen to be applicable for all cities. The goals for moving towards increased smartness and sustainability differs between cities. Thus, based on their economic power or/and population growth etc, the cities can also select appropriate indicators among those listed in Appendix I and/or add new ones.

These Technical Specifications are applicable for both cities and city regions, which could be organized in different ways:

- A single city organized as one or more administrative units, or
- A union of cities in the neighboring area that can share some services.

## 2 References

---

- [ITU-T L.KPIs-overview]    *Technical Specifications on overview of key performance indicators in smart sustainable cities (2014)*
- [ITU-T L.KPIs-impact]    *Technical Specifications on key performance indicators related to the sustainability impacts of information and communication technology in smart sustainable cities*
- [ITU-T L.KPIs-Supp]    *Technical Report on key performance indicators definitions for smart sustainable cities*

[ITU-T TR SSC Def]	<i>Technical Report on smart sustainable cities: an analysis of definitions (2014)</i>
[ITU-T TR EMF Con]	<i>Technical Report on EMF consideration in smart sustainable cities (2014)</i>
[UN-Habitat report]	UN Habitat report (2013), <i>State of the World's cities 2012/2013 Prosperity of Cities</i>
[ISO 37120]	ISO 37120:2014, <i>Sustainable development and resilience of communities – Indicators for city services and quality of life.</i>
[OECD KE]	Organisation for Economic Co-operation and Development (1996), <i>The knowledge-based economy.</i>

## 3 Definitions

---

### 3.1 Terms defined elsewhere

These Technical Specifications use the following terms defined elsewhere:

**3.1.1 City** [ITU-T L.KPIs-overview]: an urban geographical area with one (or several) local government and planning authorities.

**3.1.2 City sustainability** [ITU-T L.KPIs-overview]: the sustainability of smart city is based on four main aspects:

- Economic: the ability to generate income and employment for the livelihood of the inhabitants.
- Social: the ability to ensure well-being (safety, health, education etc) of the citizens can be equally delivered despite differences in class, race or gender.
- Environmental: the ability to protect future quality and reproducibility of natural resources.
- Governance: the ability to maintain social conditions of stability, democracy, participation, and justice.

**3.1.3 Knowledge economy** [OECD KE]: Economies which are directly based on the production, distribution and use of knowledge and information.

**3.1.4 Smart sustainable cities** [ITU-T TR SSC Def]: A smart sustainable city is an innovative city that uses information and communication technologies (ICTs) and other means to improve quality of life, efficiency of urban operation and services, and competitiveness, while ensuring that it meets the needs of present and future generations with respect to economic, social, environmental as well as cultural aspects.

### 3.2 Terms defined in these Technical Specifications

These Technical Specifications define the following terms:

**3.2.1 Big data:** big data includes a set of techniques and technologies that require new forms of integration to uncover large hidden values from large data sets that are diverse, complex, and of a massive scale in SSC.

**3.2.2 ICT companies:** companies which provide products and/or services with respect to Information and Communication Technologies.

## 4 Abbreviations and acronyms

---

These Technical Specifications use the following abbreviations and acronyms:

COP	Child Online Protection
DSL	Digital Subscriber Line
EMF	Electromagnetic Field
GDP	Gross Domestic Product
GHG	Greenhouse Gas
GIS	Geographic Information System
ICT	Information and Communication Technology
IDI	ICT Development Index
ISO	International Organization for Standardization
ITU	International Telecommunication Union
KPI	Key Performance Indicator
LAN	Local Area Network
SSC	Smart Sustainable Cities
UN-Habitat	United Nations Human Settlements Programme
WHO	World Health Organization

## 5 General principles for Key Performance Indicators (KPIs) for ICT in a city context

---

The selection of KPIs is based on the following principles:

- **Comprehensiveness:** The set of indicators should cover all the aspects of SSC. The indicators of evaluation should be aligned to the measured subject, i.e., ICT and its impact on the sustainability of cities. The index system should reflect the level of general development in a certain aspect.
- **Comparability:** The KPIs should be defined in a way that data can be compared scientifically between different cities according to different phases of urban development, which means the KPIs must be comparable over time and space. It should also be possible to extend and amend the set of KPIs according to the actual development.
- **Availability:** The KPIs should be quantitative and the historic and current data should be either available or easy to collect.
- **Independence:** The KPIs in the same dimension should be independent or almost-orthogonal i.e., overlap of the KPIs should be avoided as much as possible.
- **Simplicity:** The concept of each indicator should be simple and easy to understand. Also the calculation of the associated data should be intuitive and simple.
- **Timeliness:** The ability to produce KPIs with respect to emerging issues in SSC construction.

## 6 Key Performance Indicators

### 6.1 Sub-dimensions of KPIs

The sub-dimensions for each dimension are recorded in Table 1. These have been tailored from the Table 1 of [ITU-T L.KPIs-overview].

In the table below each dimension is identified by the letter Dx. The sub-dimensions are then classified by the label Dx.y where x denotes the dimension and Y maps to sub-dimension.

**Table 1 – Sub-dimension of KPIs**

Dimension label	Dimension	Sub-dimension <sup>2</sup> label	Sub-dimension
D1	Information and Communication Technology	D1.1	Network and access
		D1.2	Services and Information platforms
		D1.3	Information security and privacy
		D1.4	Electromagnetic field
D2	Environmental sustainability	D2.1	Air quality
		D2.5	Water, soil and noise
D3	Productivity	D3.1	Capital investment
		D3.4	Trade
		D3.8	Innovation
		D3.9	Knowledge economy
D4	Quality of life	D4.1	Education
		D4.2	Health
		D4.3	Safety/security public place
D5	Equity and social inclusion	D5.3	Openness and public participation
		D5.4	Governance
D6	Physical infrastructure	D6.1	Infrastructure/connection to services – piped water
		D6.2	Infrastructure/ connection to services – sewage
		D6.3	Infrastructure/ connection to services – electricity
		D6.8	Infrastructure/connection to services – road infrastructure
		D6.11	Building

<sup>2</sup> Note that this list only contains the sub-categories for which indicators are defined in this document. For a total set of sub-categories refer to [ITU-T L.KPIs-overview].



## 6.2 Key performance indicators of SSC

This part of the Technical Specifications defines the core indicators applicable for all cities that want to become a SSC.

Each indicator is labeled (I.x.y.z), where (i) x denotes the dimension, (ii) y the sub-dimension and (iii) z the indicator.

The indicators listed in Appendix I are proposed as additional indicators for consideration. Cities can select appropriate ones among those, and/or add new indicators, to evaluate the contributions of ICT to their SSC goals.

NOTE – In this text the *e-service* concept (e.g., e-health and e-governance etc) is used in an inclusive way and refers to both wired and wireless services that benefit the cities and city inhabitants. The mobile wireless services could also be referred to as *m-services* (e.g., m-health, m-banking etc.). These ICT services and goods are also collectively known as *Smart services* (e.g., Smart grid, Smart lighting) and *Smart goods* (e.g., Smart meters). In some cases the Smart service/ goods concept is used instead of *e-service* if this terminology is more widely adopted for the referred service or goods.

Note: In this document the term *city inhabitant* is used to refer to the people living in the city.

### 6.2.1 ICT

This clause lists the core indicators defined for ICT dimension.

There are 11 indicators in this dimension, covering *computer penetration, Internet access, fixed (wired)-broadband subscriptions, wireless-broadband subscriptions, social media, information security, COP, privacy protection, and EMF consideration in cities, etc.*

Sub-dimension	Indicator	Description
D1.1 Networks and access	I1.1.1 Availability of computers or similar devices	Proportion of households with at least one computer or similar device (tablet, smart phones, etc.) (*)
	I1.1.2 Availability of Internet access in households	Proportion of households with Internet access for any household member via a fixed or mobile network at any given time. (*)
	I1.1.3 Availability of fixed broadband subscriptions	Fixed (wired) broadband subscriptions per 100 inhabitants. (*) NOTE – Fixed (wired) broadband subscriptions refer to subscriptions for high-speed access to the public Internet (a TCP/IP connection). High-speed access is defined as downstream speed equal to, or greater than, 256 kbits/s. Fixed (wired) broadband includes broadband through cable modem, DSL, fiber and other fixed (wired) broadband technologies (such as Ethernet LAN, and broadband-over-power line (BPL) communications). Mobile cellular network subscriptions are not included.

Sub-dimension	Indicator	Description
	I1.1.4 Availability of wireless broadband subscriptions	Wireless-broadband subscriptions per 100 inhabitants (*) NOTE – Wireless broadband subscriptions include wireless broadband through satellite broadband, terrestrial fixed wireless broadband and mobile cellular network subscriptions.
D1.2 Services and information platforms	I1.2.1 Use of social media by the public sector	Use of social media by the public sector, to share information about regulations and to get feedback. NOTE – Social media refers to a group of Internet-based applications that allow the creation and exchange of user-generated content.
D1.3 Information security and privacy	I1.3.1 Information security of public services and systems	Proportion of incidents, due to illegal system access, unauthorized data storage or transmission, unauthorized hardware and software modifications, which lead to information disclosure or financial loss.
	I1.3.2 Existence of systems, rules and regulations to ensure Child Online Protection (COP)	Existence of rules and regulations to ensure COP. This also includes proportion of public web services and devices that ensure COP. NOTE – The city could work against cyber bullying by ensuring safety in online public services (for the use of ICT in schools, etc.).
	I1.3.3 Existence of systems, rules and regulations to ensure Privacy protection in public service	Existence of rules and regulations to ensure privacy protection in public service. This should also include proportion of public services and devices that ensure privacy protection. NOTE – This indicator evaluates the adoption of K-anonymity privacy preserving scheme, and other systems to ensure privacy of the city inhabitants. In addition, the rules, and regulations also require that institutions which offer consumers financial products or services like loans, financial advice, investment advice, or insurance; to safeguard sensitive and confidential information by explaining their information-sharing practices to their customers.

Sub-dimension	Indicator	Description
D1.4 Electromagnetic field	I1.4.1 Compliance with WHO endorsed exposure guidelines	Application of WHO endorsed exposure guidelines for ICT installations in the city. <sup>3</sup> NOTE – WHO endorsed exposure guidelines are referred to in [ITU-T TR EMF Con].
	I1.4.2 Adoption of a consistent planning approval process with respect to EMF	Application of a consistent planning approval process with respect to EMF to enable efficient deployment of ICT systems . NOTE – A consistent planning approval process between cities is preferred to individual city requirements to ensure efficient deployment.
	I1.4.3 Availability of EMF information	Availability of information for the public and other stakeholders and referencing WHO and ITU resources regarding compliance, health and installation issues.
NOTE – Indicators marked by (*) are based on ITU ICT Development Index ( <a href="https://www.itu.int/ITU-D/ict/publications/idi/index.html">https://www.itu.int/ITU-D/ict/publications/idi/index.html</a> )		

### 6.2.2 Environmental sustainability

This clause lists the core indicators defined for Environmental Sustainability.

There are 3 indicators in this dimension, covering *air quality, water resource, and noise monitoring etc.*

Sub-dimension	Indicator	Description
D2.1 Air quality	I2.1.1 Application of ICT based monitoring system for particles and toxic substances	Proportion of city area covered by outdoor ICT based monitoring system for particles and toxic substances NOTE – This indicator captures to what extent ICT monitors the air pollution (PM10, PM2.5, toxic substances etc.).
D2.5 Water, soil and noise	I2.5.1 Application of city water monitoring through ICT	Proportion of the city water resources (rivers, lakes, etc.) monitored by ICT with respect to water pollution and quality. NOTE – Quality of drinking water forms part of Physical infrastructure.
	I2.5.2 Application of ICT based noise monitoring	Proportion of the city area with applied ICT based noise monitoring NOTE – This indicator measures how ICT is used to monitor how the city inhabitants are exposed to acoustical noise within city areas, especially focusing on noise sensitive areas.

<sup>3</sup> ICT devices are regulated nationally and are not included.

### 6.2.3 Productivity

This clause lists the core indicators defined for productivity and economic sustainability.

There are 8 indicators in this dimension, covering *expenditure of ICT R&D, expenditure of ICT projects, ICT companies ratio, ICT employers, intangible investment, e-commerce, e-services and cloud computing.*

Sub-dimension	Indicator	Description
D3.1 Capital investment	I3.1.1 ICT related Research and Development expenditure	Proportion of city GDP spent on ICT related Research and Development NOTE – This covers investment in ICT related Research and Development including academic research input.
	I3.1.2 Investment intensity in ICT projects enabling SSC	The amount of city investments in programs, initiatives and awards that enhance the smartness and sustainability of the city, expressed as proportion of city GDP. NOTE – These projects could be sponsored by grant makers, multilateral organisations and/or private sector.
D3.4 Trade	I3.4.1 Application of e-commerce transactions	Number of e-commerce transactions per 100 inhabitants through electronic and mobile payment.
D3.8 Innovation	I3.8.1 Research and Development intensity in ICT	Proportion of research and development intensive ICT companies among all companies. NOTE – Research and development intensive ICT companies refer to ICT companies with high focus on research and development efforts.
D3.9 Knowledge economy	I3.9.1 Intangible investments as a proportion of GDP	Proportion of intangible investments (e.g., Research and development, software, design, marketing, education and training) in new and existing businesses expressed as proportion of city GDP.
	I3.9.2 Employees belonging to ICT sector	Proportion of employees in ICT among all employees. NOTE – Employees in smart industries to be added if possible.
	I3.9.3 Companies providing e-services	Proportion of companies which provide network based services (including e-commerce, e-learning, e-entertainment, cloud computing etc.). NOTE – Data collection may be challenging due to data gaps.
	I3.9.4 Application of computing platforms	Proportion of companies that offer cloud computing and similar resources serving the public, other companies, government and other organizations.

## 6.2.4 Quality of life

This clause lists the core indicators defined for Quality of Life.

There are 7 indicators in this dimension, covering *e-learning, electronic health records, electronic medical records, sharing medical information, telemedicine, anti-disaster and other safety measures*.

Sub-dimension	Indicator	Description
D4.1 Education	I4.1.1 Use of e-learning system	The proportion of city inhabitants using e-learning systems.
D4.2 Health	I4.2.1 Use of electronic health records	Proportion of city inhabitants with electronic health records. NOTE – A health record is different from a medical record and contains information on weight, height, heart rate, BMI, etc.
	I4.2.2 Use of electronic medical records	Proportion of city inhabitants who have electronic medical records.
	I4.2.3 Sharing of medical resources and information among hospitals, pharmacies and other health care providers	Proportion of hospitals, pharmacies and health care providers using ICT means for sharing of medical resources such as hospital beds, and medical information, especially electronic medical records.
	I4.2.4 Adoption of telemedicine	Proportion of patients involved in telemedicine programs including services, such as e-consultation, e-monitoring, online health care advice and guidance, etc.
D4.3 Safety/security public place	I4.3.1 Adoption of ICT for disaster management	Adoption of an ICT based disaster management system including disaster preparedness, prevention, mitigation, and response as applicable to the city. NOTE – Disasters may be natural or man-made.
	I4.3.2 Availability of ICT based safety systems	Availability of ICT based systems that increase the perceived safety. NOTE – This may include solutions such as video surveillance system, online information published by the police, online support for protection of women and children, community incident mapping etc.

### 6.2.5 Equity and social inclusion<sup>4</sup>

This clause lists the core indicators defined for equity and social inclusion.

There are 6 indicators in this dimension, covering *online city information, civic engagement, support for new city inhabitants, ICT literacy, online administering, and support to persons with specific needs*.

Sub-dimension	Indicator	Description
D5.3 Openness and public participation	I5.3.1 Availability of online city information and feedback mechanisms	Proportion of city information available online and existence of ICT systems for easy access and anonymous feedback mechanism that enable cities to improve their governance. NOTE – Online city information include city plans, budget, minutes of city governance meetings etc.
	I5.3.2 Online civic engagement	Proportion of city inhabitants using online information and proportion of city inhabitants using ICT based feedback mechanism.
	I5.3.3 Online support for new city inhabitants	Availability of ICT based applications and services to provide establishment support for new city inhabitants. NOTE – New city inhabitants include people moving to the city and visitors
	I5.3.4 Existence of strategies, rules and regulations to enable ICT literacy among inhabitants	Existence of strategies, regulations, voluntary work or interest organizations to enhance ICT literacy among all city inhabitants. NOTE – This includes mechanisms that enable public knowledge and skill development.
D5.4 Governance	I5.4.1 Provision of online systems for administering public services and facilities	Proportion of public services and facilities (e.g., choice of schools, booking of public sports facilities, library services, etc.) that could be administered online. NOTE – This includes bookings, payments etc.
	I5.4.2 Application of services to support persons with specific needs	Proportion of public facilities and buildings that provide ICT based services and information to support persons with specific needs, and proportion of online public information customized for these persons. NOTE – Persons with specific needs here indicate indigenous people, and persons with disabilities including age related disabilities.

<sup>4</sup> In general equity and inclusion in relation to ICT are difficult to measure by defining specific indicators. Therefore, in addition to the indicators defined in dimension D5, cities are encouraged to disaggregate and analyse their data with respect to aspects such as gender, age, income, specific needs and geographic location/area.



## 6.2.6 Physical infrastructure

This clause lists the core indicators defined for the physical infrastructure.

There are 13 indicators in this dimension, covering *the infrastructures including piped water, sewage, electricity, road infrastructure and building.*

Sub-dimension	Indicator	Description
D6.1 Infrastructure/ connection to services – piped water	I6.1.1 Water supply system management using ICT	Proportion of the water supply systems under automatic monitoring using ICT so as to ensure water quality and reduce leakage.
	I6.1.2 City fresh water sources monitored using ICT	Proportion of the city fresh water sources monitored using ICT with respect to availability.
	I6.1.3 Availability of smart water meters	Proportion of the water consumers (including households, companies, etc.) with ICT based water meters.
D6.2 Infrastructure/ connection to services - sewage	I6.2.1 Sewage system management using ICT	Proportion of the sewage system monitored using ICT NOTE – Monitoring includes both inspection and controlling.
	I6.2.2 Drainage system management using ICT	Proportion of the drainage systems monitored in real-time using ICT. NOTE – Monitoring includes both inspection and controlling.
D6.3 Infrastructure/ connection to services – electricity	I6.3.1 Availability of smart electricity meters	Proportion of the electricity consumers (including households, companies, etc.) with ICT based electricity meters.
D6.8 Infrastructure/ connection to services – road infrastructure	I6.8.1 Availability of traffic monitoring using ICT	Proportion of streets with traffic monitoring using ICT (e.g., using sensors to produce traffic volume maps etc.)
	I6.8.2 Availability of parking guidance systems	Proportion of parking lots and street parking spaces with ICT based parking guidance systems.
	I6.8.3 Availability of real-time traffic information	Proportion of public transport stops and stations with real-time traffic information available (via electronic bus bulletin boards, smartphone apps etc.) NOTE – Public transportation includes e.g., metro, bus, tram, train and ferry.
	I6.8.4 Street lighting management using ICT	Proportion of street lamps under automatic management using ICT (e.g., light/sound control and solar power charging). NOTE – Management covers both inspection and regulation.

Sub-dimension	Indicator	Description
	16.8.5 Gas system management using ICT	Proportion of gas supply systems under automatic monitoring using ICT.
D6.11 Building	16.11.1 Automatic energy management in buildings	Proportion of public and private sector buildings using ICT based systems to automatically regulate and reduce their energy needs.
	16.11.2 Integrated management in public buildings	Proportion of public buildings using integrated ICT systems to automate building management and create flexible, effective, comfortable and secure environment. NOTE – ICT systems include building management, communication and control systems, etc.

## Appendix I

### Additional indicators

The indicators listed in the following table are proposed as additional indicators for consideration. Cities can select appropriate ones among those, and/or add new indicators, in order to evaluate the contributions of ICT to their SSC goals. Each additional indicator is labeled (Ax.y.z), where (i) x denotes the dimension, (ii) y the sub-dimension and (iii) z the indicator.

Sub-dimension	Indicator	Description
D1.1 Networks and access	A1.1.1 Availability of mobile-cellular telephones	Mobile-cellular telephone subscriptions per 100 inhabitants (*).
	A1.1.2 International Internet bandwidth	International Internet bandwidth (bit/s) per Internet user (*) NOTE – This is the sum of used capacity of all Internet exchanges offering international bandwidth. If capacity is asymmetric, then the incoming capacity is used. International Internet bandwidth (Mbit/s) per Internet user is calculated by converting to bits per second and dividing by the total number of Internet users.
	A1.1.3 Use of Internet by city inhabitants	Proportion of inhabitants using internet.
	A1.1.4 Coverage rate of digital broadcasting network	Proportion of digital broadcasting network covering families in the city.
	A1.1.5 Availability of ultrahigh speed wireline connection	Proportion of households with access to downstream speeds equal to, or greater than, 30 Mbits/s.
	A1.1.6 Availability of highspeed mobile broadband.	Proportion of city area which provides access to downstream speeds equal to, or greater than, 10 Mbits/s.
	A1.1.7 Availability of WiFi in public areas	Number of WiFi hotspots at certain points in the city center.
	A1.1.8 Availability of smart phones and tablets	Number of smart phones and tablets per 100 inhabitants.
	A1.1.9 Quality of fixed broadband	Mean-download speed (fixed)
	A1.1.10 Quality of mobile broadband	Cell-edge performance (mobile)
D1.2 Services and information platforms	A1.2.1 Availability of electronic and mobile payment platforms	Existence of electronic and mobile payment platforms to facilitate access to city services for city inhabitants.

Sub-dimension	Indicator	Description
D3.9 Knowledge economy	A3.9.1 Intangible investments in comparison with total investments	Proportion of intangible investments (e.g., research and development, software, design, marketing, education and training) in new and existing businesses related to overall investments.  NOTE – Such investments are related to the knowledge economy, and include investments in emerging high technology and in upgrading of traditional areas.
	A3.9.2 Application of Geographic Information System (GIS)	Proportion of e-service companies with core business related to GIS serving the public, companies, government and other organizations.
	A3.9.3 Application of big data	Proportion of e-service companies with core business related to big data storage and analysis serving the public, companies, government and other organizations.
D4.1 Education	A4.1.1 Application of e-learning in schools	Proportion of pupils in primary and secondary schools having access to e-learning systems.
	A4.1.2 Application of e-learning in academic studies	Proportion of students aiming at an academic degree performing their education mainly through e-learning systems.
D5.3 Openness and public participation	A5.3.1 Availability of cultural resources online	Proportion of cultural institutions and events in the city for which online participation is offered.  NOTE – The indicator measures how ICT increases the availability of cultural resources, such as museums, galleries, etc., to a broader audience.
D5.4 Governance	A5.4.1 Existence of strategy, rules and regulations to enable the use of public data	Existence of a framework to enable the use of public data of cities.
D6.1 Infrastructure/ connection to services – piped water	A6.1.1 Availability of visualised real-time information regarding water use	Proportion of users with real-time information on quantum of water usage and water use pattern.

Sub-dimension	Indicator	Description
D6.3 Infrastructure/ connection to services – electricity	A6.3.1 Electricity supply system management using ICT	Proportion of power substation and user points under automatic inspection using ICT.  NOTE – Management of electricity supply is an important ICT task, but data may not be available to cities.
	A6.3.2 Availability of visualised real-time information regarding electricity use	Proportion of users with real-time information on quantum of electricity usage and electricity use pattern.
D6.8 Infrastructure/ connection to services – road infrastructure	A6.8.1 Availability of visualised real-time information regarding gas use	Proportion of users with real-time information on quantum of gas usage and gas use pattern.
	A6.8.2 Availability of online bike/car sharing system	Proportion of city area covered by an online bike/car sharing system
NOTE – Indicators marked by (*) are based on ITU ICT Development index ( <a href="https://www.itu.int/ITU-D/ict/publications/idi/index.html">https://www.itu.int/ITU-D/ict/publications/idi/index.html</a> )		

## Appendix II

### UN habitat City Prosperity Index

In the **Wheel of Prosperity** as defined by UN Habitat, the "spokes" are the five dimensions of prosperity: Productivity, Infrastructure development, Quality of life, Equity and social inclusion, and Environmental sustainability.

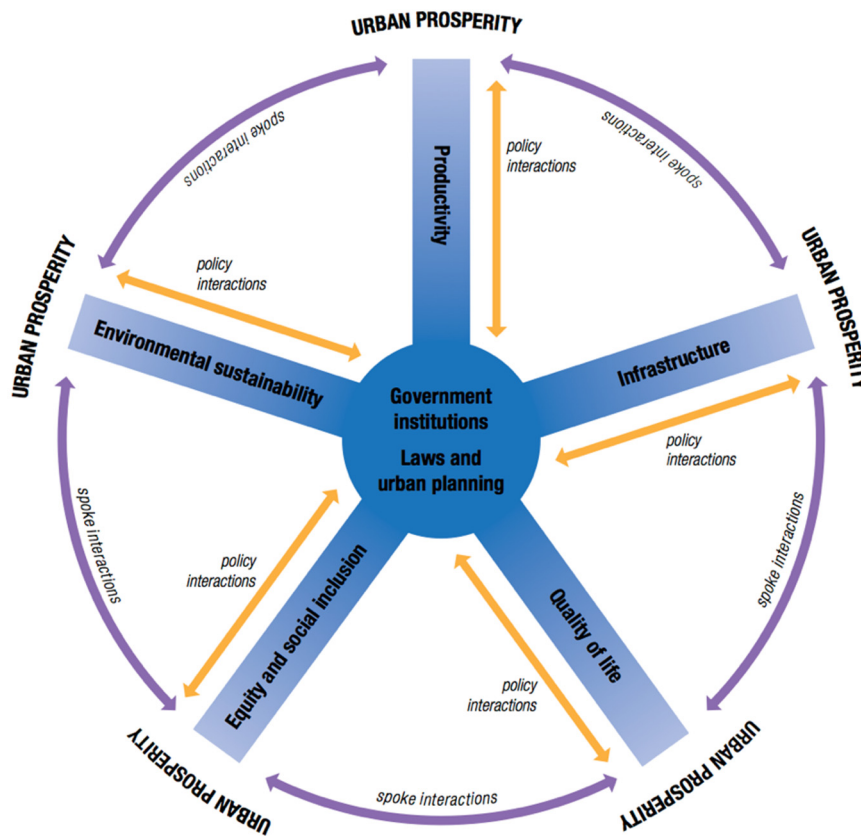


Figure 1 – Wheel of Prosperity

In the City Prosperity Index each dimension has its own index and it might be built up by a number of indices. The basic City Prosperity Index as reported in a publication consists of the following sub-indices and indicators:

Dimension	Definition/variables
Productivity	The productivity index is measured through the city product, which is composed of the variables: capital investment, formal/informal employment, inflation, trade, savings, export/import, and household income/consumption. The city product represents the total output of goods and services (value added) produced by a city’s population during a specific year.
Quality of life	The quality of life index is a combination of four sub-indices: education, health, safety/security and public space. The sub-index education includes literacy, primary, secondary and tertiary enrolment. The sub-index health includes life expectancy, under-five mortality rates, HIV/AIDS, morbidity and nutrition variables.



Dimension	Definition/variables
Infrastructure development	The infrastructure development index combines two sub-indices: one for infrastructure and another for housing. The infrastructure sub-index includes: connection to services (piped water, sewage, electricity and ICT), waste management, knowledge infrastructure, health infrastructure, transport and road infrastructure. The housing sub-index includes building materials and living space.
Environmental sustainability	The environmental sustainability index is made of four sub-indices: air quality (PM10), CO <sub>2</sub> emissions, energy and indoor pollution.
Equity and social inclusion	The equity and social inclusion index combines statistical measures of inequity of income/consumption (Gini coefficient) and social and gender inequity of access to services and infrastructure.

Reference: UN Habitat report "State of the World's cities 2012/2013 Prosperity of Cities", Table 1.1.3, p 18.

There is also an extended City Prosperity Index with more indicators and a plan to include Governance as a sixth dimension. Furthermore, specific work has been done on Streets as a driver for prosperity.

UN Habitat (2013), *State of the World's Cities 2012/2013, Prosperity of Cities*: <http://www.unhabitat.org/pmss/listItemDetails.aspx?publicationID=3387>

UN Habitat (2013), *Streets as Public Spaces and Drivers of Urban Prosperity*: <http://www.unhabitat.org/pmss/listItemDetails.aspx?publicationID=3513>

## Bibliography

[b-FG-SSC KPIs metrics]	FG-SSC deliverable, <i>Technical Report on metrics and evaluation of key performance indicators for smart sustainable cities</i>
[b-FG-SSC overview]	FG-SSC deliverable (2014), <i>Technical Report on an overview of smart sustainable cities and the role of information and communication technologies.</i>
[b-FG-SSC infrastructure]	FG-SSC deliverable, <i>Technical Report on overview of smart sustainable cities infrastructure</i>
[b-FG-SSC security]	FG-SSC deliverable, <i>Technical Report on cyber-security, data protection and cyber-resilience in smart sustainable Cities.</i>
[b-FG-SSC building]	FG-SSC deliverable, <i>Technical Report on smart buildings for smart sustainable cities.</i>
[b-FG-SSC water]	FG-SSC deliverable (2014), <i>Technical Report on smart water management in cities.</i>
[b-FG-SSC management]	FG-SSC deliverable, <i>Technical Report on integrated management for smart sustainable cities.</i>
[b-FG-SSC stakeholders]	FG-SSC deliverable, <i>Technical Report on engaging stakeholders for smart sustainable cities.</i>
[b-ISO TDS 37151.1]	ISO TDS 37151.1:2014, <i>Smart community infrastructures – Principles and requirements for performance metrics.</i>

Validation leading measurement metrics important team productivity teamwork  
Metrics measurement important customer satisfaction  
KEY PERFORMANCE INDICATORS  
directional teamwork  
framework expectations team  
organization future management  
sustainability in process resources directional measurement  
goal team directional



# 4.3

Key performance indicators related to the sustainability impacts of information and communication technology in smart sustainable cities

## Acknowledgements

These Technical Specifications were researched and authored by Ziqin Sang (Fiberhome Technologies Group), Hongqing Ding (Fiberhome Technologies Group), Masayuki Higashi (Japan), Jiro Nakamura (NTT), Minako Hara (NTT), Takafumi Hashitani (Fujitsu), Junnosuke Sugiura (Fujitsu), Claudio Di Carlo (Italy), Paola Girdinio (Genoa University), Raffaele Bolla (Genoa University), Paolo Gemma (Huawei), Dewei Xu (Fiberhome Technologies Group), Jia Guo (Fiberhome Technologies Group), Pernilla Bergmark (Ericsson), Lelio Digeronimo (Avina), Luis Castiella (San Andrés University), Mike Wood (Telstra), Jack Rowley (GSMA), Christer Tornevik (Ericsson), Christophe Grangeat (Alcatel-Lucent), N.S. Deepu (India), Leonidas Anthopoulos (Technological Education Institute of Thessaly) and Sebastien Ziegler (Mandat International).

The authors wish to extend their gratitude to Ramy Ahmed Fathy (NTRA, Egypt), Michael Mulquin (IS Communications), James Njeru (Kenya), Thomas Luti (Kenya), Angelica V Ospina (University of Manchester), Mythili Menon (University of Geneva), for their valuable inputs and support.

The authors acknowledge the guidance and support from all the members of the ITU-T Focus Group on Smart Sustainable Cities (FG-SSC) Management Team.

Additional information and materials relating to these Technical Specifications can be found at: [www.itu.int/itu-t/climatechange](http://www.itu.int/itu-t/climatechange). If you would like to provide any additional information, please contact Cristina Bueti (ITU) at [tsbsg5@itu.int](mailto:tsbsg5@itu.int).

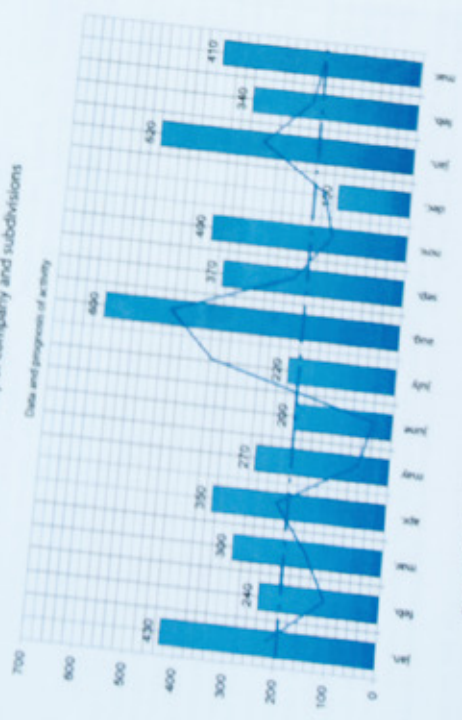
## Table of Contents

		<b>Page</b>
<b>1</b>	<b>Scope.....</b>	<b>800</b>
<b>2</b>	<b>References.....</b>	<b>801</b>
<b>3</b>	<b>Definitions.....</b>	<b>801</b>
	3.1 Terms defined elsewhere.....	801
<b>4</b>	<b>Abbreviations and acronyms .....</b>	<b>802</b>
<b>5</b>	<b>General principles for key performance indicators for ICT in a city context .....</b>	<b>802</b>
<b>6</b>	<b>Key performance indicators.....</b>	<b>803</b>
	6.1 Sub-dimensions of KPIs .....	803
	6.2 Key performance indicators for smart sustainable cities .....	804
	<b>Appendix I – Additional indicators .....</b>	<b>810</b>
	<b>Appendix II – UN-Habitat City Prosperity Index.....</b>	<b>812</b>
	<b>Bibliography.....</b>	<b>814</b>





Business activity of company and subdivisions  
Date and progress of activity



Detailed information of changing business activity of subdivisions of main company

## Key performance indicators related to the sustainability impacts of information and communication technology in smart sustainable cities

### Executive summary

These Technical Specifications give general guidance to cities and provide for the definition of key performance indicators (KPIs) related to the sustainability impacts of information and communication technology (ICT) in the context of smart sustainable cities (SSCs).

These Technical Specifications are expected to become an ITU-T Recommendation.

### Keywords

Cities, information and communication technologies (ICTs), smart sustainable cities (SSCs), sustainability impacts.

### Introduction

According to the terms of reference (ToR) of the Focus Group on Smart Sustainable Cities (FG-SSC), one of the objectives is to:

- Identify or develop a set of key performance indicators (KPIs) to assess how the use of ICTs has an impact on the environmental<sup>1</sup> sustainability of cities.

One of the specific tasks and deliverables of FG-SSC is to:

- Develop a document of KPIs to assess the impact of the use of ICT projects in cities.

This document is one of the deliverables developed by the FG-SSC and defines the KPIs. The series of KPI definitions deliverables include:

- Technical Specifications on overview of key performance indicators in smart sustainable cities [ITU-T L.KPIs-overview].
- Technical Specifications on key performance indicators related to the use of information and communication technology in smart sustainable cities [ITU-T L.KPIs-ICT]. This document lists the KPIs focusing on ICT use in SSC.
- Technical Specifications on key performance indicators related to the sustainability impacts of information and communication technology in smart sustainable cities. This document lists the KPIs proposed for ICT impact on sustainability.
- Technical Report on key performance indicators definitions for smart sustainable cities [ITU-T L.KPIs-Supp]. This document provides the information regarding existing KPIs and evaluation index systems of smart cities, KPIs of sustainable cities, etc.

In this document FG-SSC proposes ICT related KPIs in alignment with the definition of SSC while considering the dimensions of such a city. This document is aligned with the framework provided by UN-Habitat in its City Prosperity Index with respect to the categorization of indicators as described in Appendix II and further detailed in [ITU-T L.KPIs-overview].

---

<sup>1</sup> The terms of reference of FG-SSC particularly mention environmental sustainability. However, this document tries to have a broader perspective and embraces also indicators that are related to quality of life, social and economic aspects.

# 1 Scope

---

These Technical Specifications form part of a series of Technical Reports and Technical Specifications focusing on key performance indicators (KPIs) for smart sustainable cities (SSCs). It specifically provides the KPIs related to ICT impact on city sustainability in the context of SSC. Evaluating these indicators can help cities as well as their stakeholders understand the extent to which they may be perceived as SSC. These Technical Specifications describe applicability of KPIs, principles, dimensions as well as the definitions of corresponding indicators. To fit into the overall framework of city indicators the present Technical Specifications re-use the categorization of UN-Habitat's City Prosperity Index.

These Technical Specifications can be utilized by:

- Cities and municipal administrations, including the SSC-relevant policy-making organizations, and government sectors, enabling them to develop strategies and understand the progress related to the use of ICT for making cities smarter and more sustainable.
- City inhabitants and their non-profit organizations, enabling them to understand the development and progress of SSC with respect to the impact of ICT.
- Development and operation organizations of SSC, including planning unit, SSC-related producers and service providers, operation and maintenance organizations, helping them fulfill the tasks of sharing information related to the use of ICT and its impact on the sustainability of cities.
- Evaluation agencies and academia, supporting them in selection of relevant KPIs for assessing the contribution from ICT in the development of SSC.

The intention of identifying the KPIs is to establish the criteria to evaluate ICT's contributions in making cities smarter and more sustainable, and to provide the cities with the means for self-assessments. It is desirable that cities are able to quantify their achievement according to their goals.

The ICT solutions include ICT goods, networks and services as well as ICT projects. An ICT project is defined as a set of activities that uses mainly ICT goods, networks and services to implement a specific task. At a city level, ICT projects particularly target the deployment of ICT in different parts of society to improve the sustainability performance in SSC. The KPIs can be used to assess the city sustainability before and after the implementation of ICT solutions.

These Technical Specifications list the core indicators that are chosen as applicable to all cities. The goals for moving towards increased smartness and sustainability differs between cities. Thus, based on their stage of economic development or/and population growth etc., the cities can also select appropriate indicators among those listed in Appendix I and/or use new ones.

These Technical Specifications are applicable to both cities and city regions, which could be organized in different ways:

- A single city organized as one or more administrative units, or
- A union of cities in the neighboring area that can share some services.

## 2 References

---

[ITU-T L.KPIs-overview]	<i>Technical Specifications on overview of key performance indicators in smart sustainable cities (2014).</i>
[ITU-T L.KPIs-ICT]	<i>Technical Specifications on key performance indicators related to the use of information and communication technology in smart sustainable cities.</i>
[ITU-T L.KPIs-Supp]	<i>Technical Report on key performance indicators definitions for smart sustainable cities.</i>
[ITU-T TR SSC Def]	<i>Technical Report on smart sustainable cities: an analysis of definitions (2014).</i>
[UN Habitat report]	UN Habitat (2013), <i>State of the World's cities 2012/2013, Prosperity of Cities.</i>
[ISO 37120]	ISO 37120:2014, <i>Sustainable development and resilience of communities – Indicators for city services and quality of life.</i>
[OECD KE]	Organisation for Economic Co-operation and Development (1996), <i>The knowledge-based economy.</i>

## 3 Definitions

---

### 3.1 Terms defined elsewhere

These Technical Specifications use the following terms defined elsewhere:

**3.1.1 City** [ITU-T L.KPIs-overview]: An urban geographical area with one (or several) local government and planning authorities.

**3.1.2 City sustainability** [ITU-T L.KPIs-overview]: The sustainability of smart city is based on four main aspects:

- Economic: The ability to generate income and employment for the livelihood of the inhabitants.
- Social: The ability to ensure well-being (safety, health, education, etc.) of the citizens can be equally delivered despite differences in class, race or gender.
- Environmental: The ability to protect future quality and reproducibility of natural resources.
- Governance: The ability to maintain social conditions of stability, democracy, participation, and justice.

**3.1.3 ICT companies** [ITU-T L.KPIs-ICT]: Companies which provide products and/or services with respect to information and communication technologies.

**3.1.4 Knowledge economy** [OECD KE]: Economies which are directly based on the production, distribution and use of knowledge and information.

**3.1.5 Smart sustainable cities** [ITU-T TR SSC Def]: A smart sustainable city is an innovative city that uses information and communication technologies (ICTs) and other means to improve quality of life, efficiency of urban operation and services, and competitiveness, while ensuring that it meets the needs of present and future generations with respect to economic, social, environmental as well as cultural aspects.



## 4 Abbreviations and acronyms

---

These Technical Specifications use the following abbreviations and acronyms:

AIDS	Acquired Immune Deficiency Syndrome
GDP	Gross Domestic Product
GHG	Greenhouse Gas
HIV	Human Immunodeficiency Virus infection
HLY	Healthy Life Years
ICT	Information and Communication Technology
ISO	International Organization for Standardization
ITU	International Telecommunication Union
KPI	Key Performance Indicator
PM10	Particulate Matter up to 10 micrometres in size
PM2.5	Particulate Matter up to 2.5 micrometres in size
QoL	Quality of Life
SSC	Smart Sustainable City
ToR	Terms of Reference
UN-Habitat	United Nations Human Settlements Programme

## 5 General principles for key performance indicators for ICT in a city context

---

The selection of KPIs is based on the following principles:

- **Comprehensiveness:** The set of indicators should cover all the aspects of SSC. The indicators for evaluation should be aligned to the measured subject, i.e., ICT and its impact on the sustainability of cities. The index system should reflect the level of general development for a certain aspect.
- **Comparability:** The KPIs should be defined in a way that the data can be compared scientifically between different cities according to different phases of urban development, which means the KPIs must be comparable over time and space. It should also be possible to extend and amend the set of KPIs according to the actual stage of development.
- **Availability:** The KPIs should be quantitative and the historic and current data should be either available or easy to collect.
- **Independency:** The KPIs in the same dimension should be independent or almost-orthogonal i.e., overlap of the KPIs should be avoided as much as possible.
- **Simplicity:** The concept of each indicator should be simple and easy to understand. Also the calculation of the associated data should be intuitive and simple.

- **Timeliness:** This is defined as the ability to produce KPIs with respect to emerging issues in SSC construction.

## 6 Key performance indicators

### 6.1 Sub-dimensions of KPIs

The sub-dimensions for each dimension are listed in Table 1. These have been tailored from the Table 1 of [ITU-T L.KPIs-overview].

In Table 1, each dimension is identified by the letter Dx. The sub-dimensions are then classified by the label Dx.y where x denotes the dimension and y maps the sub-dimension.

**Table 1 – Sub-dimension of KPIs**

Dimension label	Dimension	Sub-dimension label	Sub-dimension
D2	Environmental sustainability	D2.1	Air quality
		D2.2	CO <sub>2</sub> emissions
		D2.3	Energy
		D2.5	Water, soil and noise
D3	Productivity	D3.1	Capital investment
		D3.2	Employment
		D3.3	Inflation
		D3.5	Savings
		D3.6	Export/import
		D3.7	Household income/consumption
		D3.8	Innovation
D4	Quality of life	D4.1	Education
		D4.2	Health
		D4.3	Safety/security public place
D5	Equity and social inclusion	D5.1	Inequity of income/consumption (Gini coefficient)
		D5.2	Social and gender inequity of access to services and infrastructure
		D5.3	Openness and public participation



Dimension label	Dimension	Sub-dimension label	Sub-dimension
D6	Physical infrastructure	D6.1	Infrastructure/connection to services – piped water
		D6.2	Infrastructure/connection to services – sewage
		D6.3	Infrastructure/connection to services – electricity
		D6.6	Infrastructure/connection to services – health infrastructure
		D6.7	Infrastructure/connection to services – transport
NOTE - This list contains only the sub-categories for which indicators are defined in this document. For a total set of sub-categories, refer to [ITU-T L.KPIs-overview].			

## 6.2 Key performance indicators for smart sustainable cities

This section defines the core indicators applicable for all cities.

Each indicator is labeled (Ix.y.z), where (i) x denotes the dimension, (ii) y, the sub-dimension, and (iii) z, the indicator.

NOTE – The numbering of indicator Ix,y,z of this document follows that of [ITU-T L.KPIs-ICT].

The indicators listed in Appendix I are proposed as additional indicators for consideration. Cities can select appropriate ones among those, and/or add new indicators, in order to evaluate the sustainability impacts related to the use of ICT.

NOTE – These Technical Specifications contain ICT specific indicators and general indicators<sup>2</sup> which describe the sustainability impacts in the context of smart sustainable cities. Due to the complexity of cities and the wide range of factors that impact citizens' behaviour, impacts from ICT could in many cases mainly be tracked for specific projects or initiatives. For this reason, the general city level KPIs are defined for areas where ICT could have an impact, though it is not the only change lever. Thus, to understand the ICT impact on the general KPIs, depth analysis is needed based on a broad understanding of the general city development.

NOTE – Although convenience and comfort is an important aspect of SSC, there are no KPIs defined for the sub-dimension D4.4 Convenience and comfort [ITU-T L.KPIs-overview]. However, it is important that ICT projects are designed in a way that is convenient for the intended users. Therefore it is good to combine the use of KPIs with other assessment methods to understand the satisfaction level linked to the use of such projects and how these KPIs develop over time.

NOTE – In this text the *e-service* concept (e.g., e-health and e-governance etc.) is used in an inclusive way and refers to both wired and wireless services that benefit cities and city inhabitants. The mobile wireless services could also be referred to as *m-services* (e.g., m-health, m-banking etc.). These ICT services and goods can be also collectively termed as *Smart services* (e.g., Smart grid, Smart lighting) and *Smart goods* (e.g., Smart meters). In some cases the *Smart service / smart goods* concept may be used instead of *e-service* if this terminology is more widely adopted for the referred service or goods.

NOTE – In this document the term *city inhabitant* is used to refer to the people living in the city.

<sup>2</sup> The general indicators are marked (\*).

### 6.2.1 Environmental sustainability

This clause lists the core indicators defined for environmental sustainability.

There are 10 indicators in this dimension, covering *air pollution, GHG emissions, renewable energy, energy saving in households, environment perception, quality of water resources, recycling of waste, noise and soil pollution, and green areas etc.*

Sub-dimension	Indicator	Description
D2.1 Air quality	I2.1.2 Air pollution intensity	Level of particles and toxic substances. (*) NOTE – This includes toxic substances and particles such as PM10 and PM2.5.
D2.2 CO <sub>2</sub> emissions (**)	I2.2.1 GHG emissions	Amount of GHG emissions per capita. (*) NOTE – It is preferred to distinguish between emissions emerging from industrial (manufacturing, construction), commercial, household, transport, and waste disposal, etc.
D2.3 Energy	I2.3.1 Use of alternative and renewable energy	Proportion of renewable energy consumed in the city. (*) NOTE – Renewable energy sources include geothermal, solar thermal, solar voltaic, hydro, wind, and combustible renewable sources and waste (composed of solid biomass, liquid biomass, bio-gas, industrial waste and municipal waste).
	I2.3.2 Energy saving in households	Energy saving in households compared to a baseline. (*) NOTE – The baseline may be either a previous measurement or a reference value. NOTE – It would be preferred to distinguish between households with and without smart meters, and with and without home automation systems.
D2.5 Water, soil and noise	I2.5.3 Quality of city water resources	Quality of water resources (rivers, lakes etc.). (*) NOTE – Pollution of water resources includes (but is not limited to) acidity, organic, floatables, alga, chemical substances and bacteria, etc.
	I2.5.4 Recycling of waste	Proportion of waste recycled compared to total collected waste. (*)
	I2.5.5 Exposure to noise	Proportion of the city inhabitants with noise levels above international/national exposure limits at home. (*) NOTE – Noise is measured as sound pressure in accordance with relevant international/national standards.

Sub-dimension	Indicator	Description
	I2.5.6 Soil pollution avoidance	Proportion of soil pollution incidents with successful early warning and emergency detection of heavy metal, chemicals and acid etc. through ICT.
	I2.5.7 Green areas surface	Proportion of municipal territory allocated to publicly accessible green areas. (*)
	I2.5.8 Perception on environmental quality	Proportion of city inhabitants satisfied with the urban environment. (*)
NOTE – Indicators marked by (*) are not ICT specific indicators but indicators focusing on general city sustainability. NOTE – This sub-dimension marked by (**) looks into the CO <sub>2</sub> -e/GHG emissions of the city where "-e" is "equivalent" and all other greenhouse gases are converted into CO <sub>2</sub> .		

## 6.2.2 Productivity

This clause lists the core indicators defined for productivity and economic sustainability.

There are 7 indicators in this dimension, covering *expenditure of ICT to improve industry productivity, service industry employment, saving, city export/import, household ICT expenditures, ICT investment, and ICT related patents etc.*

Sub-dimension	Indicator	Description
D3.1 Capital investment	I3.1.3 Improvement of industry productivity through ICT	Productivity enhancement in industry through ICT measured as the impact of ICT on value added per person employed. NOTE – This is the contribution from ICT investment. NOTE – Value added per person employed is generally referred to as labour productivity.
D3.2 Employment	I3.2.1 Service industry employment	Proportion of employees working in service industry in the city compared with the total employed workforce. (*)
D3.5 Savings	I3.5.1 Saving rate	Proportion of total incomes for each household remaining after deducting consumption and expenditures. (*)
D3.6 Export/import	I3.6.1 Knowledge-intensive export/import	Proportion of export/import of knowledge-intensive goods and services within a city compared to the total industrial export/import. (*) NOTE – Amount of export/import may be counted among cities, maybe in the same country. NOTE – In some cases data is only available at country level.
D3.7 Household income/consumption	I3.7.1 Household ICT expenditures	Proportion of household expenditures related to ICT.

Sub-dimension	Indicator	Description
D3.8 Innovation	I3.8.2 Investments in ICT innovation	Proportion of private sector expenditures invested in ICT innovation.
	I3.8.3 ICT related patents	Number of ICT related patents granted per capita.
NOTE – Indicators marked by (*) are not ICT specific indicators but indicators focusing on general city sustainability.		

### 6.2.3 Quality of life

This clause lists the core indicators defined for Quality of Life (QoL).

There are 3 indicators in this dimension, covering *student ICT availability, inhabitants health statuses, and emergency process to improve safety and security*.

Sub-dimension	Indicator	Description
D4.1 Education	I4.1.2 Students ICT availability	Proportion of students/pupils with access to ICT capabilities in school. NOTE – ICT capabilities include Internet connectivity, computer labs, ICT modules, digital learning, etc.
D4.2 Health	I4.2.5 Healthy life years (HLY)	Number of remaining years that a person of a certain age is expected to live without disability. (*) NOTE – The emphasis is not exclusively on the length of life, as is the case for life expectancy, but also on the quality of life.
D4.3 Safety/security public place	I4.3.3 Disaster and emergencies alert accuracy	Proportion of disasters and emergencies with timely alerts. (*) NOTE – Disasters may be natural or man-made. Emergencies concern incidents like kidnapping and missing people, etc.
NOTE – Indicators marked by (*) are not ICT specific indicators but indicators focusing on general city sustainability.		

### 6.2.4 Equity and social inclusion<sup>3</sup>

This clause lists the core indicators defined for equity and social inclusion.

There are 4 indicators in this dimension, covering *income inequity, gender inequity, use of online services and perception on social inclusion etc.*

<sup>3</sup> In general equity and inclusion in relation to ICT are hard to measure by defining specific indicators. Therefore, in addition to the indicators defined in dimension D5, cities are encouraged to disaggregate and analyse their data with respect to other aspects including gender, age, income and geographic location/area.

Sub-dimension	Indicator	Description
D5.1 Inequity of income/consumption (Gini coefficient)	15.1.1 Income distribution	Income distribution in accordance with Gini coefficient. (*)
D5.2 Social and gender inequity of access to services and infrastructure	15.2.1 Gender income disparity	Rate of income disparity between men and women. (*) NOTE – Income has potential influence on equity of access to services and infrastructure.
D5.3 Openness and public participation	15.3.5 Use of online city services	Proportion of city inhabitants using online public services and facilities (e.g., choice of schools, booking of public sports facilities, library services, etc.). NOTE – This includes bookings, payments etc.
	15.3.6 Perception on social inclusion	Proportion of city inhabitants satisfied with the social inclusion. (*) NOTE – Social inclusion usually refers to members of society feeling valued and important.
NOTE – Indicators marked by (*) are not ICT specific indicators but indicators focusing on general city sustainability.		

### 6.2.5 Physical infrastructure<sup>4</sup>

This clause lists the core indicators defined for the physical infrastructure.

There are 6 indicators in this dimension, covering *piped water, sewage, electricity, health infrastructure, transport and road traffic*.

Sub-dimension	Indicator	Description
D6.1 Infrastructure /connection to services – piped water	16.1.4 Leakage in water supply system	Proportion of water leakage in the water supply system. (*)
D6.2 Infrastructure /connection to services – sewage	16.2.3 Sewage system coverage	Proportion of households connected to the sewage system. (*)
D6.3 Infrastructure /connection to services – electricity	16.3.2 Reliability of electricity supply system	Proportion of time during which electricity supply system works without outages. (*)

<sup>4</sup> The number of various sensors (per capita) deployed in the city and accessibility to the public administration is very important.

Sub-dimension	Indicator	Description
D6.6 Infrastructure /connection to services – health infrastructure	16.6.1 Availability of sporting facilities	Number of sports training facilities per capita. (*)
D6.7 Infrastructure /connection to services – transport	16.7.1 Use of public transport	Proportion of travellers utilizing public transportation compared to overall city population. (*)
	16.7.2 Road traffic efficiency	Freedom from traffic congestion exposure. (*) NOTE – Traffic congestion is measured in accordance with relevant international/national standards. For example, in terms of average speed of vehicle or average delay.
NOTE – Indicators marked by (*) are not ICT specific indicators but indicators focusing on general city sustainability.		



## Appendix I

### Additional indicators

The indicators listed in the following table are proposed as additional indicators for consideration. Cities can select appropriate ones among those, and/or add new indicators, to evaluate the contributions of ICT to their SSC goals. Each additional indicator is labeled (Ax.y.z), where (i) x denotes the dimension, (ii) y, the sub-dimension, and (iii) z, the indicator.

Sub-dimension	Indicator	Description
D2.2 CO <sub>2</sub> emissions (**)	A2.2.1 GHG emissions per sector per capita	GHG emissions per capita per sector including industrial (manufacturing, construction), commercial, household, transport, and waste disposal etc. (*)
D2.3 Energy	A2.3.1 Electricity use for street lighting	Electricity used for street lighting per capita. (*)
D3.2 Employment	A3.2.1 Creative industry employment	Proportion of employees working in start-ups and creative industry in the city compared to the total employed workforce. (*) NOTE – Creative industries refer to those ones that are based on individual creativity, skill and talent with the potential to create wealth and jobs through developing intellectual property. This includes thirteen sectors: advertising, architecture, the art and antiques market, crafts, design, designer fashion, film, interactive leisure software (i.e., video games), music, the performing arts, publishing, software, and television and radio.
D3.3 Inflation	A3.3.1 Inflation rate	A city's inflation rate is based on a projection of its Consumer Price Index, which measures the rise in prices of goods and services. (*) NOTE – National inflation data may be used. NOTE – A +2% inflation rate is regarded as a target or healthy inflation rate by major international banks.
D4.2 Health	A4.2.1 Coverage of health insurance	Proportion of city inhabitants covered by health insurances. (*) NOTE – Health insurances may be either private or provided by authorities.

Sub-dimension	Indicator	Description
D5.3 Openness and public participation	A5.3.2 Interest in online access to cultural resources	On-line visits to cultural resources per capita.
D6.1 Infrastructure /connection to services – piped water	A6.1.2 Quality of piped water	Quality of water as supplied to end users. (*) NOTE – Quality is impacted by both water treatments and distribution systems.
NOTE – Indicators marked by (*) are not ICT specific indicators but indicators focusing on general city sustainability.		
NOTE – This sub-dimension marked by (**) looks into the CO <sub>2</sub> -e/GHG emissions of the city where "-e" is "equivalent" and all other greenhouse gases are converted into CO <sub>2</sub> .		

## Appendix II

### UN-Habitat City Prosperity Index

In the Wheel of Prosperity as defined by UN-Habitat, the "spokes" are the five dimensions of prosperity: productivity, infrastructure development, quality of life, equity and social inclusion, and environmental sustainability.

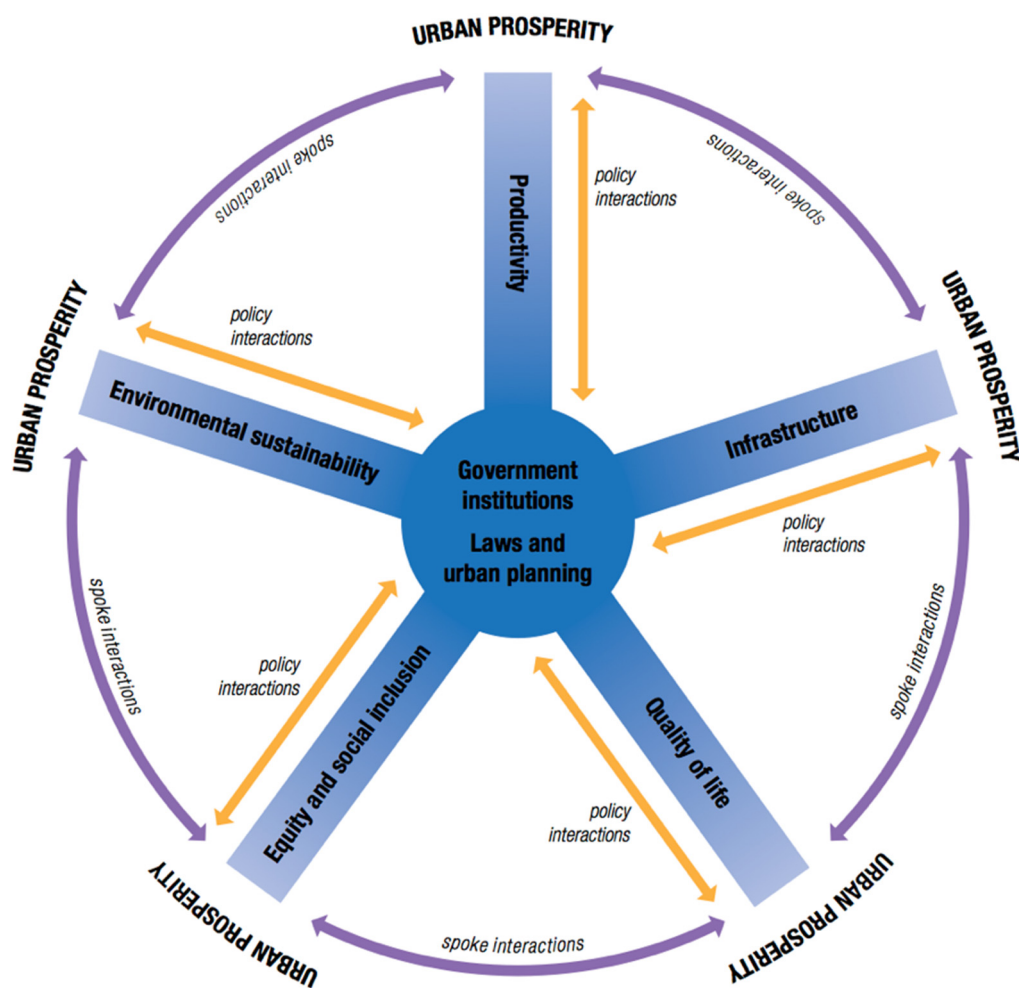


Figure 1 – Wheel of Prosperity

In the "City Prosperity Index" each dimension has its own index and it might be built up by a number of indices. The basic "City Prosperity Index" as reported in a publication consists of the following sub-indices and indicators:

Dimension	Definition/variables
Productivity	The productivity index is measured through the city product, which is composed of the variables capital investment, formal/informal employment, inflation, trade, savings, export/import, and household income/consumption. The city product represents the total output of goods and services (value added) produced by a city's population during a specific year.
Quality of life	The quality of life index is a combination of four sub-indices: education, health, safety/security and public space. The sub-index education includes literacy, primary, secondary and tertiary enrolment. The sub-index health includes life expectancy, under-five mortality rates, HIV/AIDS, morbidity and nutrition variables.
Infrastructure development	The infrastructure development index combines two sub-indices: one for infrastructure and another for housing. The infrastructure sub-index includes: connection to services (piped water, sewage, electricity and ICT), waste management, knowledge infrastructure, health infrastructure, transport and road infrastructure. The housing sub-index includes building materials and living space.
Environmental sustainability	The environmental sustainability index is made of four sub-indices: air quality (PM10), CO <sub>2</sub> emissions, energy and indoor pollution.
Equity and social inclusion	The equity and social inclusion index combines statistical measures of inequity of income/consumption (Gini coefficient) and social and gender inequity of access to services and infrastructure.

## Reference

UN Habitat report "State of the World's cities 2012/2013 Prosperity of Cities", table 1.1.3, p. 18.

There is also an extended "City Prosperity Index" with more indicators and a plan to include "Governance" as a sixth dimension. Furthermore, a specific work has been made on Streets as a driver for prosperity.

UN Habitat (2013), *State of the World's Cities 2012/2013, Prosperity of Cities*: <http://www.unhabitat.org/pmss/listItemDetails.aspx?publicationID=3387>

UN Habitat (2013), *Streets as Public Spaces and Drivers of Urban Prosperity*: <http://www.unhabitat.org/pmss/listItemDetails.aspx?publicationID=3513>

## Bibliography

- [b-FG-SSC KPIs metrics] FG-SSC deliverable, *Technical Report on metrics and evaluation of key performance indicators for smart sustainable cities.*
- [b-FG-SSC overview] FG-SSC deliverable (2014), *Technical Report on an overview of smart sustainable cities and the role of information and communication technologies.*
- [b-FG-SSC infrastructure] FG-SSC deliverable, *Technical Report on overview of smart sustainable cities infrastructure.*
- [b-FG-SSC security] FG-SSC deliverable, *Technical Report on cyber-security, data protection and cyber-resilience in smart sustainable cities.*
- [b-FG-SSC building] FG-SSC deliverable, *Technical Report on smart sustainable buildings for smart sustainable cities.*
- [b-FG-SSC water] FG-SSC deliverable (2014), *Technical Report on smart water management in cities.*
- [b-FG-SSC management] FG-SSC deliverable, *Technical Report on integrated management for smart sustainable cities.*
- [b-FG-SSC stakeholders] FG-SSC deliverable, *Technical Report on engaging stakeholders for smart sustainable cities.*
- [b-ISO TDS 37151.1] ISO TDS 37151.1:2014, *Smart community infrastructures - Principles and requirements for performance metrics.*



business  
implementation  
data  
analyze  
selling

implement

analyze

note

kpi

writing

resource

index

system

process

key

PI

indicator

performance

manager

in

te

o

improvement



A green rectangular sign with rounded corners is mounted on a silver metal pole. The sign has a white border and two small white circles on the left side, resembling mounting holes. The text on the sign is in white, bold, sans-serif font. The main text is split into two lines: 'KEY PERFORMANCE' on the top line and 'INDICATOR' on the bottom line. Below this, the text 'FOR SSC' is written in a smaller font size.

# KEY PERFORMANCE INDICATOR

FOR SSC



# 4.4

**Key performance  
indicators definitions  
for smart  
sustainable cities**

**Technical Specifications**

## Acknowledgements

This Technical Report was researched and authored by Ziqin Sang (Fiberhome Technologies Group), Hongqing Ding (Fiberhome Technologies Group), Masayuki Higashi (Japan), Jiro Nakamura (NTT), Minako Hara (NTT), Takafumi Hashitani (Fujitsu), Junnosuke Sugiura (Fujitsu), Claudio Di Carlo (Italy), Paola Girdinio (Genoa University), Raffaele Bolla (Genoa University), Paolo Gemma (Huawei), Dewei Xu (Fiberhome Technologies Group), Jia Guo (Fiberhome Technologies Group), Pernilla Bergmark (Ericsson), Lelio Digeronimo (Avina) and Luis Castiella (San Andrés University)

The authors wish to extend their gratitude to Ramy Ahmed Fathy (NTRA, Egypt), Michael Mulquin (IS Communications), Angelica V Ospina (University of Manchester), Mythili Menon (University of Geneva), Erica Campilongo (International Telecommunication Union) and Cristina Bueti (International Telecommunication Union) for their valuable inputs and support.

The authors also acknowledges the guidance and support from all the members of the ITU-T FG-SSC Management Team.

Additional information and materials relating to this Technical Report can be found at: [www.itu.int/itu-t/climatechange](http://www.itu.int/itu-t/climatechange). If you would like to provide any additional information, please contact Cristina Bueti (ITU) at [tsbsg5@itu.int](mailto:tsbsg5@itu.int).

## Table of Contents

	<b>Page</b>
<b>1 Introduction .....</b>	<b>822</b>
1.1 Scope .....	822
<b>2 References.....</b>	<b>823</b>
<b>3 Definitions.....</b>	<b>823</b>
3.1 Terms defined elsewhere.....	823
3.2 Terms defined in this Technical Report .....	823
<b>4 Abbreviations and acronyms .....</b>	<b>824</b>
<b>5 Analysis of key performance indicators systems.....</b>	<b>826</b>
<b>6 Conclusions .....</b>	<b>846</b>
<b>Annex A – ISO: Index system of smart city .....</b>	<b>847</b>
<b>Annex B – ITU: ICT development index (IDI) .....</b>	<b>848</b>
<b>Annex C – UN-Habitat: City prosperity index.....</b>	<b>849</b>
<b>Annex D – China Institute of Communications (CIC): Index system of smart city .....</b>	<b>851</b>
<b>Annex E – China, Ministry of Housing and Urban-Rural Development (MOHURD): Index system of national pilot smart city.....</b>	<b>854</b>
<b>Annex F – EU: European common indicators .....</b>	<b>857</b>
<b>Annex G – Italy: Index system of smart city and smart statistics .....</b>	<b>861</b>
<b>Annex H – Japan: Index system of SSC being discussed in the sub working group for SSC of the Telecommunication Technology Committee (TTC).....</b>	<b>865</b>
<b>Annex I – GCIF: Global city indicators facility.....</b>	<b>867</b>
<b>Annex J – ICLEI: Global protocol for community scale GHG emissions (GPC).....</b>	<b>872</b>
<b>Annex K – ESCI: Indicators of the emerging and sustainable cities initiative.....</b>	<b>874</b>
<b>Annex L – Vienna University of Technology: European ranking of medium-sized cities .....</b>	<b>882</b>
<b>Annex M – Leibnitz Institute: European system of social indicators .....</b>	<b>885</b>
<b>Annex N – Smart Cities Wheel.....</b>	<b>894</b>
<b>Annex O – Ericsson: Networked society city index .....</b>	<b>896</b>
<b>Annex P – IBM: Smarter city assessment.....</b>	<b>899</b>
<b>Annex Q – IDC: Index system of SSC .....</b>	<b>901</b>
<b>Annex R – PwC: Cities of opportunities index.....</b>	<b>906</b>
<b>Annex S – Siemens: Green city index.....</b>	<b>913</b>
<b>Bibliography .....</b>	<b>915</b>



## Key performance indicators definitions for smart sustainable cities

### Executive summary

This Technical Report is a deliverable of the ITU-T Focus Group on Smart Sustainable Cities (FG-SSC) and is part of a series of Technical Reports and Technical Specifications focusing on key performance indicators (KPIs) for smart sustainable cities (SSC). This Technical Report is intended to supplement and provide further background on the content provided in the “Technical Specifications on overview of key performance indicators in smart sustainable cities”, which was approved during the FG-SSC meeting held in Geneva, October 2014. It is also intended to complement the “Technical Specifications on key performance indicators related to the use of information and communication technology in smart sustainable cities” and the “Technical Specifications on key performance indicators related to the sustainability impacts of information and communication technology in smart sustainable cities”.

This Technical Report provides a comparative analysis of nineteen different index sets. Supplementary information on each of the approaches reviewed is presented in the annexes, thus providing a comprehensive background of the resources that formed the FG-SSC series of KPIs Technical Reports and Technical Specifications.

In order to ensure the inclusion of a wide array of perspectives, the indexes reviewed originate from international sources, national/regional sources, city organization sources, academic sources, and company sources. By doing so, the analysis evidenced the broad set of perspectives and approaches used to measure and assess the performance of SSC, and in particular, the role of ICTs in urban sustainability, thus demonstrating the importance of KPIs development for smart sustainable cities.

This Technical Report is structured around four main sections. Section one provides the introductory background and scope. Section 3 presents a series of key definitions used as the basis for this Technical Report. Section 5 presents the comparative analysis of indicators, structured around the five dimensions that characterize SSC strategies (i.e. ICT, environmental sustainability, productivity, quality of life, equity and social inclusion, and physical infrastructure). Based on this analysis, section 6 offers reflections and concluding remarks.

The comparative review presented in this Technical Report provides a valuable background for the discussions held by the members of ITU's FG-SSC, particularly for the exchanges that took place between the members of Working Group 3 focused on KPIs and metrics. It also helps to understand the development of the series of KPIs Technical Reports and Technical Specifications, confirming ITU-T FG-SSC commitment to the development of robust metrics that can serve as the basis for the development of standards in this field.



# 1 Introduction

---

Within the context of an increasingly interconnected society, information and communication technologies (ICTs) are playing a role as part of novel approaches to address urban challenges. They are an intrinsic component of smart sustainable cities (SSC), contributing to the improvement of citizens' quality of life, the provision of public services, and the achievement of sustainable development goals, among others.

Both established as well as emerging ICTs, including mobile broadband, Internet of things, cloud computing, big data, and next-generation networks (NGNs), have been involved in the establishment of smart sustainable city strategies. Many of these tools are being deployed globally, giving momentum to the next revolution of technology and industry that combine intelligent and sustainable features. However, as the design and implementation of SSC strategies continues to unfold, it becomes vital to develop robust indicators that allow to monitor, measure, and better understand both the technical requirements, as well as the social and environmental implications of ICTs use in urban settings.

In order to further enhance the understanding of how ICT solutions can make cities smarter and more sustainable, as well as to support decision-makers, practitioners and citizens alike in the development of novel approaches to urban development, ITU-T Focus Group on Smart Sustainable Cities (FG-SSC) is developing a set of key performance indicators (KPIs) to measure and assess ICT's impact on SSC.

## 1.1 Scope

The purpose of this Technical Report is to serve as a supplement to the content presented in the series of KPIs Technical Reports (TRs) and Technical Specifications (TSs) developed by FG-SSC, by presenting an overview of the analysis and the background resources used to show the development of those TRs and TSs.

This Technical Report provides a general overview of a key set of indicators related to the use of information and communication technology (ICT) and corresponding impacts on city sustainability in smart sustainable cities (SSC). It is intended for an audience of SSC decision-makers and strategists, interested in gaining a more in-depth understanding of existing knowledge and approaches to indexes and KPIs for SSC. This Technical Report illustrates the vast body of resources gathered on the evaluation index systems of smart cities and KPIs for sustainable cities, among others, that served as a background for the development of related series of KPIs Technical Reports and Technical Specifications. The resources presented in this Technical Report were analysed with respect to common elements, and a set of indicators focusing on ICT and its contribution to smart sustainable cities was developed.

## 2 References

---

[ITU-T TR SSC Def]	<i>Technical Report on smart sustainable cities: an analysis of definitions (2014).</i>
[ITU-T TR EMF Con]	<i>Technical Report on electromagnetic field (EMF) consideration in smart sustainable cities (2014).</i>
[UN-Habitat report]	UN-Habitat report (2013), <i>State of the World's cities 2012/2013 Prosperity of Cities.</i>
[OECD KE]	Organisation for Economic Co-operation and Development (1996), <i>The knowledge-based economy.</i>

## 3 Definitions

---

### 3.1 Terms defined elsewhere

This Technical Report uses the following terms defined elsewhere:

**3.1.1 knowledge economy** [OECD KE]: "An economy whose most important elements are the possession, control, production and utility of knowledge and intelligent resources", while 'knowledge based economy' is an expression "coined to describe trends in advanced economies towards greater dependence on knowledge, information and high skill levels, and the increasing need for ready access to all of these by the business and public sectors".

**3.1.2 smart sustainable cities** [ITU-T TR SSC Def]: A smart sustainable city is an innovative city that uses information and communication technologies (ICTs) and other means to improve quality of life, efficiency of urban operation and services, and competitiveness, while ensuring that it meets the needs of present and future generations with respect to economic, social, environmental as well as cultural aspects.

### 3.2 Terms defined in this Technical Report

This Technical Report defines the following term:

#### 3.2.1 City sustainability

The sustainability of a city is based on four main aspects:

- Economic: The ability to generate income and employment for the livelihood of the inhabitants;
- Social: The ability to ensure well-being (safety, health, education, etc) of the citizens can be equally delivered despite differences in class, race or gender;
- Environmental: The ability to protect future quality and reproducibility of natural resources;
- Governance: The ability to maintain social conditions of stability, democracy, participation, and justice.

## 4 Abbreviations and acronyms

---

This Technical Report uses the following abbreviations and acronyms:

3G	Third Generation mobile networks
AIDS	Acquired Immune Deficiency Syndrome
API	Application Programming Interface
BB	BroadBand
CAGR	Compound Annual Growth Rate
CBD	Central Business District
CIC	China Institute of Communications
ECDL	European Computer Driving License
EHR	Electronic Health Record
EMF	Electromagnetic Field
ERMC	European Ranking of Middle-sized Cities
ESCI	Emerging and Sustainable Cities Initiative
EUSI	European System of Social Indicators
EV	Electric Vehicle
FDI	Foreign Direct Investment
FTTx	Fibre to the x (B – building, business; H – Home; C – Cabinet, Curb)
GCIF	Global City Indicators Facility
GDP	Gross Domestic Product
GHG	Greenhouse Gas
GIS	Geographic Information System
GP	General Practitioner
GPC	Global Protocol for Community scale GHG emissions
HDV	Heavy Duty Vehicle
HIV	Human Immunodeficiency Virus infection
HQ	Headquarter
HSPA+	Evolved High-Speed Packet Access
IBM	International Business Machine
ICLEI	International Council for Local Environmental Initiatives
ICT	Information and Communication Technology
IDC	International Data Corporation
IDI	ICT Development Index
IP	Internet Protocol
IPPU	Industrial Processes and Product Uses

ISCED	International Standard Classification of Education
ISO	International Organization for Standardization
ITS	Intelligent Transport System
ITU	International Telecommunication Union
KIS	Knowledge-Intensive Services
KPIs	Key Performance Indicators
LDV	Light Duty Vehicle
LTE	Long Term Evolution
MOHURD	Ministry of Housing and Urban-Rural Development, China
OECD	Organization for Economic Co-operation and Development
PC	Personal Computer
PCT	Patent Cooperation Treaty
PM10	Particulate Matter up to 10 micrometres in size
PPP	Purchasing Power Parity
PPS	Prospective Payment System
R&D	Research and Development
RES	Renewable Energy Source
RFID	Radio Frequency Identification
RMB	Ren Min Bi
SDR	Special Drawing Rights
SIM	Subscriber Identity Module
SSC	Smart sustainable cities
SWB	Subjective Well-Being
TEN	Trans-European Network
TR	Technical Report
TS	Technical Specifications
TTC	Telecommunication Technology Committee (TTC) of Japan
UNEP	United Nations Environment Programme
UNFCCC	United Nations Framework Convention on Climate Change
UN-Habitat	United Nations Human Settlements Programme
WG	Working Group
WiFi	Wireless Fidelity

## 5 Analysis of key performance indicators systems

This section provides an analysis of nineteen different sets of index systems and KPIs related to the use of ICTs and sustainability in cities. As demonstrated in the Technical Specifications on “Overview of key performance indicators in smart sustainable cities”, the identification of these indicators is vital to assess how the use of ICTs can have an impact on the sustainability of cities, in order to provide grounds for standardization.

Box 1 highlights some of the stakeholders and the benefits associated to the development of KPIs for SSC.

### Box. 1: Benefits of SSC KPI development

- For city dwellers and non-profit citizen organizations, by enabling them to understand the development and progress of SSC with respect to ICT's impact.
- For the development and operation of SSC organizations, including planning units, service providers, operation and maintenance organizations, among others, by helping them to fulfil the tasks of sharing information related to the use of ICTs and their impact on the sustainability of cities.
- For evaluation and ranking agencies, including academia, by supporting them in the selection of relevant KPIs for assessing the contribution from ICT in the development of SSC.

The analysis in this Technical Report is conducted through a comparison based on the key dimensions and sub-dimensions that characterize smart sustainable cities, namely:

SSC dimension	No. of indicators/sub-dimensions
<b>ICT</b>	14 indicators / cover network facilities and information facilities
<b>Environmental sustainability</b>	14 indicators / cover environment and energy and natural resources
<b>Productivity</b>	12 indicators / cover innovation and economic sustainability
<b>Quality of life</b>	22 indicators / cover convenience and comfort, security and safety, health care, and education and training
<b>Equity and social inclusion</b>	11 indicators / cover openness and public participation, social sustainability, and governance sustainability
<b>Physical infrastructure</b>	15 indicators / cover building, transport, sanitation, and municipal pipe network

These different dimensions and sub-dimensions are developed in further detail in the Technical Reports and Technical Specifications that are part of the FG-SSC KPI series (i.e. "Overview of key

performance indicators in smart sustainable cities", "Key performance indicators related to the use of information and communication technology in smart sustainable cities", and "Key performance indicators related to the sustainability impacts of information and communication technology in smart sustainable cities").

A comparative analysis of nineteen different index sets is summarized in Table 1. As per the objectives and the scope of this Technical Report, supplementary information on each of the approaches reviewed is presented in the annexes, providing a comprehensive background of the resources that formed the FG-SSC KPIs series.

In order to ensure the inclusion of a wide array of perspectives, the indexes reviewed originate from five different sources: international sources, national/regional sources, city organization sources, academic sources, and company sources, as follows:

- International sources:
  - a) The International Organization for Standardization (ISO), smart community infrastructures (Annex A);
  - b) The International Telecommunication Union (ITU), ICT development index (IDI) (Annex B);
  - c) UN-Habitat, city prosperity index (Annex C).
- National/regional sources:
  - d) China Institute of Communications, evaluation index system of a smart City (Annex D);
  - e) China, Ministry of Housing and Urban-Rural Development (MOHURD), index system of a pilot smart city (Annex E);
  - f) European Union, European common indicators (EU research initiative "Towards a local sustainability profile") (Annex F);
  - g) Italy, smart city and smart statistics (Annex G);
  - h) Japan, Sub working group for SSC of the Telecommunication Technology Committee, index system of SSC (Annex H).
- City organization sources:
  - i) Global city indicators facility, global city indicators (Annex I);
  - j) International Council for Local Environmental Initiatives (ICLEI), global protocol for community scale greenhouse gas (GHG) emissions (GPC) (Annex J);
  - k) Inter-American Development Bank, indicators of the emerging and sustainable cities initiative (ESCI) (Annex K).
- Academic sources:
  - l) Centre of Regional Science (SRF), Vienna University of Technology, European smart cities, ranking of European medium-sized cities (Annex L);
  - m) Leibnitz Institute, European system of social indicators (Annex M);
  - n) Boyd Cohen, Smart Cities Wheel (Annex N).



- Company sources:
  - o) Ericsson, networked society city index (Annex O);
  - p) IBM, smarter city assessment (Annex P);
  - q) IDC, smart cities index (Annex Q);
  - r) PricewaterhouseCoopers (PwC), cities of opportunity index (Annex R);
  - s) Siemens, green city index (Annex S).

This body of knowledge was analysed and compiled in two tables:

Table 1 compares the different indexes, identifying whether or not they include indicators related to the key SSC dimensions and sub-dimensions identified above.

Table 2 contributes further to this analysis, by identifying the number of similar indicators that exist between the different set of indicators and the SSC dimensions, as well as the percentage of similar indicators and the distribution of these indicators.

Table 1 – Comparison of KPIs between index systems and sets of KPIs

Dimension	Sub-dimension	Indicators	ISO	IDI	UN-Habitat	CIC	MOHURD	ECI	Italy	TTC	GCIF	GPC	ESCI	ERMC	EUSI	Wheel	Ericsson	IBM	IDC	PwC	Siemens		
D1 ICT	D1.1 Network facilities	I1.1.1 Fixed (wired)-broadband subscriptions per 100 inhabitants		X		X	X		X		X		X				X	X	X				
		I1.1.2 International Internet bandwidth (bit/s) per Internet user	X	X		X				X	X				X			X	X	X	X		
		I1.1.3 Wireless-broadband subscriptions per 100 inhabitants		X		X	X			X		X		X				X	X	X			
		I1.1.4 Percentage of households with Internet access	X	X		X				X		X						X	X	X	X		
		I1.1.5 Coverage rate of next-generation broadcasting network	X				X																
		I1.1.6 EMF compliance framework in place																					
		I1.1.7 Planning legislation incorporates ICT networks and antenna requirements																					

Table 1 – Comparison of KPIs between index systems and sets of KPIs

Dimension	Sub-dimension	Indicators	ISO	IDI	UN-Habitat	CIC	MOHURD	ECI	Italy	TTC	GCIF	GPC	ESCI	ERMC	EUSI	Wheel	Ericsson	IBM	IDC	PwC	Siemens			
D1.2 Information facilities		I1.1.8 ICT EMF information availability to the public																						
		I1.2.1 Percentage of enterprises providing network-based services (e-commerce, e-learning, e-entertainment, cloud computing)	X			X			X															
		I1.2.2 Proportion of business based on cloud computing				X	X																	
		I1.2.3 Proportion of business based on GIS (location, navigation, etc.)																						
		I1.2.4 Percentage of households with at least one computer		X		X				X					X			X		X				
		I1.2.5 Level of cyber-security				X																		
		I1.2.6 Ratio of children online protection																						

Table 1 – Comparison of KPIs between index systems and sets of KPIs

Dimension	Sub-dimension	Indicators	ISO	IDI	UN-Habitat	CIC	MOHURD	ECI	Italy	TTC	GCIF	GPC	ESCI	ERMC	EUSI	Wheel	Ericsson	IBM	IDC	PwC	Siemens	
D2 Environmental sustainability	D2.1 Environment	I2.1.1 Proportion of information published on environmental quality				X													X			
		I2.1.2 Progress degree of ICT in the protection of main city water resources				X					X			X		X			X	X		
		I2.1.3 Effect of flood control monitoring by means of ICT measures												X					X	X		
		I2.1.4 Proportion of water pollution control by means of ICT measures				X					X	X		X		X		X	X	X		X
		I2.1.5 Proportion of air pollution monitoring by means of ICT measures			X	X			X	X				X		X		X		X	X	X
		I2.1.6 Proportion of toxic substances monitoring by means of ICT measures				X					X											

Table 1 – Comparison of KPIs between index systems and sets of KPIs

Dimension	Sub-dimension	Indicators	ISO	IDI	UN-Habitat	CIC	MOHURD	ECI	Italy	TTC	GCIF	GPC	ESCI	ERMC	EUSI	Wheel	Ericsson	IBM	IDC	PwC	Siemens		
		I 2.1.7 Proportion of noise monitoring by means of ICT measures				X		X					X										
		I2.1.8 Solid waste disposal management with ICT measures	X		X	X					X	X		X		X		X		X	X	X	
	D2.2 Energy and natural resources	I2.2.1 Improvement of civilian electricity usage (per capita) with ICT measures				X				X	X			X	X								X
		I2.2.2 Improvement of industrial electricity usage (per GDP) with ICT measures			X	X				X	X			X	X					X			
		I2.2.3 Improvement of civilian water usage (per capita) with ICT measures						X		X	X			X	X								X
		I2.2.4 Improvement of industrial water usage (per GDP) with ICT measures						X		X	X				X								

Table 1 – Comparison of KPIs between index systems and sets of KPIs

Dimension	Sub-dimension	Indicators	ISO	IDI	UN-Habitat	CIC	MOHURD	ECI	Italy	TTC	GCIF	GPC	ESCI	ERMC	EUSI	Wheel	Ericsson	IBM	IDC	PwC	Siemens	
		I2.2.5 Improvement of fossil fuel usage with ICT measures (per GDP)	X		X		X	X	X	X							X				X	
		I2.2.6 Improvement of rare metal/noble metal usage (per GDP) with ICT measures								X												
D3 Productivity	D3.1 Innovation	I3.1.1 Percentage of R&D expenditure in GDP							X	X				X								
		I3.1.2 Ratio of knowledge-intensive enterprises							X						X					X		
		I3.1.3 Revenue share of knowledge-intensive enterprise												X								
		I3.1.4 Patent number per 100,000 inhabitant								X					X			X				
		I3.1.5 Importance as decision-making centre (HQ, etc.)													X							



Table 1 – Comparison of KPIs between index systems and sets of KPIs

Dimension	Sub-dimension	Indicators	ISO	IDI	UN-Habitat	CIC	MOHURD	ECI	Italy	TTC	GCIF	GPC	ESCI	ERMC	EUSI	Wheel	Ericsson	IBM	IDC	PwC	Siemens	
		I3.1.6 SSC new projects opportunities															X			X		
		I3.1.7 Penetration of teleworking system								X										X		
		I3.1.8 Improvement of traditional industry with ICT				X	X															
	D3.2 Economic sustainability	I3.2.1 Percentage of knowledge economy in total investment			X		X			X											X	
		I3.2.2 Percentage of knowledge economy in GDP								X											X	
		I3.2.3 Employment rate in knowledge-intensive sectors			X		X			X	X			X	X	X		X		X	X	
		I3.2.4 Percentage of e-commerce transaction amount				X	X			X	X							X	X	X		

Table 1 – Comparison of KPIs between index systems and sets of KPIs

Dimension	Sub-dimension	Indicators	ISO	IDI	UN-Habitat	CIC	MOHURD	ECI	Italy	TTC	GCIF	GPC	ESCI	ERMC	EUSI	Wheel	Ericsson	IBM	IDC	PwC	Siemens	
D4 Quality of life	D4.1 Convenience and comfort	I4.1.1 Satisfaction with online commercial and financial services				X	X			X					X	X		X	X			
		I4.1.2 Satisfaction with environmental safety				X	X									X						
		I4.1.3 Convenience of government services				X	X	X	X						X				X			
		I4.1.4 Convenience of smart traffic information administration and service				X	X							X			X			X		
		I4.1.5 Satisfaction with quality of public transport				X								X	X	X			X	X	X	
		I4.1.6 Satisfaction with crime prevention and security control				X					X			X	X	X					X	
		I4.1.7 Satisfaction with countermeasures against disaster								X				X								

Table 1 – Comparison of KPIs between index systems and sets of KPIs

Dimension	Sub-dimension	Indicators	ISO	IDI	UN-Habitat	CIC	MOHURD	ECI	Italy	TTC	GCIF	GPC	ESCI	ERMC	EUSI	Wheel	Ericsson	IBM	IDC	PwC	Siemens	
		I4.1.8 Satisfaction with food drug safety monitoring				X																
		I4.1.9 Convenience of urban medical care				X										X						
		I4.1.10 Convenience for citizens to access education resource				X								X	X	X						
		I4.1.11 Perception of proof against risk of poverty												X	X	X	X					
		I4.1.12 Satisfaction with housing conditions												X		X					X	
	D4.2 Security and safety	I4.2.1 Accident prediction ratio				X					X											
		I4.2.2 Penetration of ICT for disaster prevention					X												X	X		
		I4.2.3 Publication rate of disaster alert					X							X					X	X		
		I4.2.4 Penetration of city video surveillance																		X		

Table 1 – Comparison of KPIs between index systems and sets of KPIs

Dimension	Sub-dimension	Indicators	ISO	IDI	UN-Habitat	CIC	MOHURD	ECI	Italy	TTC	GCIF	GPC	ESCI	ERMC	EUSI	Wheel	Ericsson	IBM	IDC	PwC	Siemens		
	D4.3 Health care	I4.3.1 Percentage of archiving electronic health records for residents				X			X														
		I4.3.2 Usage rate of electronic medical records				X				X													
		I4.3.3 Sharing rate of resource and information among hospitals				X				X													
		I4.3.4 Coverage rate of household e-health services								X													
D4.4 Education and training		I4.4.1 Effectiveness of hatching smart tech from knowledge centres (research centres, universities etc.)				X								X									
		I4.4.2 Penetration of e-learning system				X				X										X			

Table 1 – Comparison of KPIs between index systems and sets of KPIs

Dimension	Sub-dimension	Indicators	ISO	IDI	UN-Habitat	CIC	MOHURD	ECI	Italy	TTC	GCIF	GPC	ESCI	ERMC	EUSI	Wheel	Ericsson	IBM	IDC	PwC	Siemens		
D5 Equity and social inclusion	D5.1 Openness and public participation	I5.1.1 Immigration-friendly environment contributed by ICT measures												X									
		I5.1.2 Improvement of turnout at city hearings by means of ICT			X	X	X			X				X	X	X				X			
		I5.1.3 Online civic engagement			X	X	X			X		X			X	X				X			X
	D5.2 Social sustainability	I5.2.1 Feasibility of appealing online			X	X				X						X				X			
		I5.2.2 Atmosphere of free online comment				X	X			X						X				X			
		I5.2.3 Contribution in increasing consciousness of citizenship and social coherence				X				X					X	X							

Table 1 – Comparison of KPIs between index systems and sets of KPIs

Dimension	Sub-dimension	Indicators	ISO	IDI	UN-Habitat	CIC	MOHURD	ECI	Italy	TTC	GCIF	GPC	ESCI	ERMC	EUSI	Wheel	Ericsson	IBM	IDC	PwC	Siemens
D5. 3 Governance sustainability		I5.3.1 Digital access to urban planning and budget document				X	X		X				X			X			X		
		I5.3.2 Appliance of smart community services																	X		
		I5.3.3 Penetration rate of government online services			X	X	X		X								X		X		
		I5.3.4 Percentage of government information open				X	X		X					X			X		X		
		I5.3.5 Penetration of smart impediment removal (accessibility) system					X							X							



Table 1 – Comparison of KPIs between index systems and sets of KPIs

Dimension	Sub-Dimension	Indicators	ISO	IDI	UN-Habitat	CIC	MOHURD	ECI	Italy	TTC	GCIF	GPC	ESCI	ERMC	EUSI	Wheel	Ericsson	IBM	IDC	PwC	Siemens				
D6 Physical infrastructure	D6.1 Building	16.1.1 Application level of energy saving technologies in public buildings				X							X		X				X						
		16.1.2 Percentage of public buildings with integrated technologies				X			X										X	X					
		16.1.3 Proportion of smart home automation adoption				X													X	X					
	D6.2 Transport	16.2.1 Coverage of installation of road sensing terminals	X			X																X			
		16.2.2 Coverage of parking guidance systems																					X		
		16.2.3 Coverage of electronic bus bulletin board																					X		
	D6.3 Sanitation	16.3.1 Sewage discharge management with ICT measures	X		X		X							X					X	X			X		

Table 1 – Comparison of KPIs between index systems and sets of KPIs

Dimension	Sub-Dimension	Indicators	ISO	IDI	UN-Habitat	CIC	MOHURD	ECI	Italy	TTC	GCIF	GPC	ESCI	ERMC	EUSI	Wheel	Ericsson	IBM	IDC	PwC	Siemens	
		16.3.2 Improvement of waste water recycling with ICT measures	X		X		X		X				X					X	X		X	
	D6.4 Municipal pipe network	16.4.1 Drainage system management with ICT measures	X		X		X											X	X			
		16.4.2 Lighting system management with ICT measures					X													X		
		16.4.3 Gas system management with ICT measures	X				X	X												X		
		16.4.5 Water saving smart metering					X												X	X		X
		16.4.6 Electricity supply system management with ICT measures	X		X		X	X						X					X	X		
		16.4.7 Improvement of underground pipelines and spatial integrated administration with ICT measures					X													X		

Table 2 – Proximity statistics of KPIs for SSC

Source	Number of similar indicators	Percentage of similar indicators (%)	Distribution of indicators
ISO	7	7.95	Internet access and bandwidth, broadcasting network, ratio of network enterprises, solid waste, fossil fuel, road sensing, sewage management, water recycling, gas management, electricity supply
IDI	5	5.68	Internet access and bandwidth, broadband subscription, wireless subscription, home computer
UN-Habitat	11	12.5	Air pollution, solid waste, industrial electricity, fossil fuel, knowledge economy, employment, accident prediction, political participation, appealing online, government online services, sewage management, water recycling, electricity supply
CIC	47	53.41	Internet access and bandwidth, broadband subscription, wireless subscriptions, ratio of network enterprises, cloud computing, home computer, cybersecurity, environmental information, water resource protection, pollution (water, air, toxic, noise, solid waste), civilian and industrial electricity, traditional industry improvement, e-commerce, e-finance, environmental safety, government services, smart traffic, public transport, security control, food and drug safety, medical care, education access, disaster alert and prevention, electronic health records, smart tech hatching, e-learning, political participation, appealing online, online freedom, social coherence, e-governance openness, government online services, building energy saving, smart building, smart home, road sensing
MOHURD	22	25	Broadband subscription, wireless subscriptions, broadcasting, cloud computing, civilian and industrial water, fossil fuel, traditional industry improvement, knowledge economy, employment, e-commerce, e-finance, environmental safety, government services, smart traffic, political participation, online freedom, e-governance openness, government online services, smart impediment, sewage management, water recycling, lighting management, gas management, smart metre, electricity supply, underground pipelines spatial integrated administration
ESCI	29	4.55	Air and noise pollution, fossil fuel, government services, gas management, electricity supply

**Table 2 – Proximity statistics of KPIs for SSC**

Source	Number of similar indicators	Percentage of similar indicators (%)	Distribution of indicators
Italy	36	40.91	Internet access and bandwidth, broadband and wireless subscriptions, ratio of network enterprises, home computer, air pollution, civilian and industrial electricity, civilian and industrial water, fossil fuel, R&D expenditure, knowledge enterprise, patent, teleworking, knowledge economy, employment, e-commerce, government services, counter-disaster satisfaction, electronic health records, household e-health, e-learning, political participation, appealing online, online freedom, social coherence, e-governance openness, government online services, smart building, water recycling
TTC	13	14.77	Internet bandwidth, water resource protection, pollution (water, toxic, solid waste), civilian and industrial electricity, civilian and industrial water, fossil fuel, rare metal, R&D expenditure, employment, e-commerce, e-finance, security control, accident prediction, political participation
GCIF	6	6.82	Broadband and wireless subscriptions, Internet access, water and solid waste pollution, anti-poverty, political participation
GPC	0	0	
ESCI	29	32.95	Broadband and wireless subscriptions, water resource protection, flood control, water pollution (water, air, noise, solid waste), civilian and industrial electricity, civilian water, smart tech revenue, employment, smart traffic, public transport, security control, counter-disaster satisfaction, education access, anti-poverty, housing comfort, disaster alert, immigration convenience, political participation, e-governance openness, smart impediment, building energy saving, sewage management, water recycling, electricity supply
ERMC	21	23.86	Internet bandwidth, civilian and industrial electricity, civilian and industrial water, R&D expenditure, knowledge enterprise, patent, decision-making centre, employment, government services, public transport, security control, education access, anti-poverty, hatching smart tech, political participation, social coherence
EUSI	19	21.59	Water resource protection, pollution (water, air, solid waste), employment, e-finance, environmental safety, public transport, security control, medical care, education access, anti-poverty, housing comfort, political participation, appealing online, online freedom, social coherence, building energy saving

Table 2 – Proximity statistics of KPIs for SSC

Source	Number of similar indicators	Percentage of similar indicators (%)	Distribution of indicators
Smart Cities Wheel (Boyd Cohen)	6	6.82	e-finance, smart traffic, anti-poverty, e-governance openness, government online services
Ericsson	13	14.77	Internet access and bandwidth, broadband and wireless subscriptions, home computer, flood control, pollution (water, air, solid waste), fossil fuel, patent, smart tech opportunities, employment, e-commerce
IBM	15	17.05	Internet access and bandwidth, broadband and wireless subscriptions, water resource protection, flood control, water pollution, e-commerce, e-finance, government services, public transport, disaster alert and prevention, smart building, smart home, sewage management, water recycling, smart metre, electricity supply
IDC	36	40.91	Internet access and bandwidth, broadband and wireless subscriptions, home computer, environmental information, water resource protection, pollution (water, air, solid waste), industrial electricity, teleworking, employment, e-commerce, e-finance, smart traffic, public transport, disaster alert and prevention, video surveillance, e-learning, political participation, appealing online, online freedom, e-governance openness, smart community, government online services, building energy saving, smart building, smart home, road sensing, parking guidance, electronic bus bulletin, sewage management, water recycling, lighting management, gas management, smart metre, electricity supply, underground pipelines spatial integrated administration
PwC	12	13.64	Internet access and bandwidth, air pollution, solid waste, knowledge enterprise, opportunities, knowledge economy, employment, public transport, security control, housing comfort
Siemens	7	7.95	Pollution (water, air, solid waste), civilian electricity and water, fossil fuel, sewage management, water recycling, smart metre

	Legend to Tables 1 and 2: Sources and indicators
ISO:	ISO/TC 268/SC1
IDI:	ITU, ICT development index
UN-Habitat:	UN-Habitat City Prosperity Index
CIC:	China Institute of Communications
MOHURD:	China, Ministry of Housing and Urban-Rural Development
ECI:	European common indicators
Italy:	Italy, smart city and smart statistics
TTC:	Sub working group for SSC of TTC in Japan
GCIF:	Global city indicators facility
GPC:	Global Protocol for Community scale GHG emissions
ESCI:	Emerging and sustainable cities initiative
ERMC:	European smart cities, European ranking of medium-sized cities
EUSI:	European system of social indicators
Wheel:	Boyd Cohen: Index system of SSC, Smart Cities Wheel
Ericsson:	Ericsson, networked society city index
IDC:	Spain, IDC smart cities index
IBM:	IBM, smarter city assessment
PwC:	PwC, cities of opportunities index
Siemens:	Green city index



## 6 Conclusions

---

This Technical Report collects a number of indicators that have been developed for cities by global, national, regional, academic and company stakeholders. The analysis evidenced the broad set of perspectives and approaches that exist in this field, but most importantly and common to all, it showed the importance attributed to measuring, monitoring, and learning from ICT usage in smart sustainable cities.

The content and supplementary information contained in this Technical Report allows the following general reflections:

- Although the specific categorization used differs between indexes, frequently used categories are economy, environment and – to some extent – governance. These are areas that have been recognized to be at the core of SSC strategies.
- The social aspect of sustainability is addressed in different ways by specific sets of indicators. Some have a main category for social aspects and add sub-categories, others do not include the social as an individual category, but instead use several categories that are related to social aspects.
- Despite the specific and sometimes diverging approaches to measuring the role of ICTs in smart city contexts, the sources reviewed confirmed the relevance of the key dimensions and sub-dimensions identified by the FG-SSC for the development of SSC KPIs. They also suggest the appropriateness of looking into ICT aspects, environmental sustainability, productivity, quality of life, equity and social inclusion, and non-ICT infrastructure development, as crucial components of smart sustainable cities.

The comparative review conducted provides a valuable background for the discussions held by the members of ITU's FG-SSC, particularly for the exchanges that took place among the members of Working Group 3 focused on KPI and metrics.

The review also helped to inform, complement and substantiate the development of the FG-SSC series of KPIs Technical Reports and Technical Specifications, specifically “Technical Specifications on overview of key performance indicators in smart sustainable cities”, “Technical Specifications on key performance indicators related to the use of information and communication technology in smart sustainable cities” and “Technical Specifications on key performance indicators related to the sustainability impacts of information and communication technology in smart sustainable cities”.

## Annex A

### ISO: Index system of smart city

Source: ISO/TC 268/SC1, Smart community infrastructures, with possible directions for the development of metrics.

[http://www.iso.org/iso/home/standards\\_development/list\\_of\\_iso\\_technical\\_committees/iso\\_technical\\_committee.htm?commid=656967](http://www.iso.org/iso/home/standards_development/list_of_iso_technical_committees/iso_technical_committee.htm?commid=656967)

**Table A.1 – Example of "community infrastructures"**

1	Energy	Power grid, gas, fuels (gas station), etc.
2	Water	Water treatment process, water for industrial use, treated water, sewage disposal, etc.
3	Mobility	Road, railroad, airport, port, river, etc.
4	Waste	Waste recovery, recycling, etc.
5	ICT	Information processing, Internet, carrier, broadcasting, etc.

**Table A.2 – Examples of "performance (to be technically improved)"**

1	Societal	Convenient	Viewpoint of resident
		Comfortable	
		Secure	
		Safe	
2	Economic	Management efficiency	Viewpoint of community managers
		Vitalization of industry	
		Rotation of generation of the residents	
3	Environmental	Global warming	Viewpoint of environmentalists, world opinions
		Natural resources saving	
		Protection of biodiversity	

## Annex B

### ITU: ICT development index (IDI)

Source: ITU Measuring the Information Society

<http://www.itu.int/ITU-D/ict/publications/idi/>

Eleven indicators for measuring the ICT development in countries are divided into three categories: ICT infrastructure and access, ICT use and ICT skills.

#### a) ICT infrastructure and access indicators

1. *Fixed-telephone subscriptions per 100 inhabitants*
2. *Mobile-cellular telephone subscriptions per 100 inhabitants*
3. *International Internet bandwidth (bit/s) per Internet user*
4. *Percentage of households with a computer*
5. *Percentage of households with Internet access*

#### b) ICT use indicators

1. *Percentage of individuals using the Internet*
2. *Fixed (wired)-broadband subscriptions per 100 inhabitants*
3. *Wireless-broadband subscriptions per 100 inhabitants*

#### c) ICT skills indicators

1. *Adult literacy rate*
2. *Secondary gross enrolment ratio*
3. *Tertiary gross enrolment ratio*

## Annex C

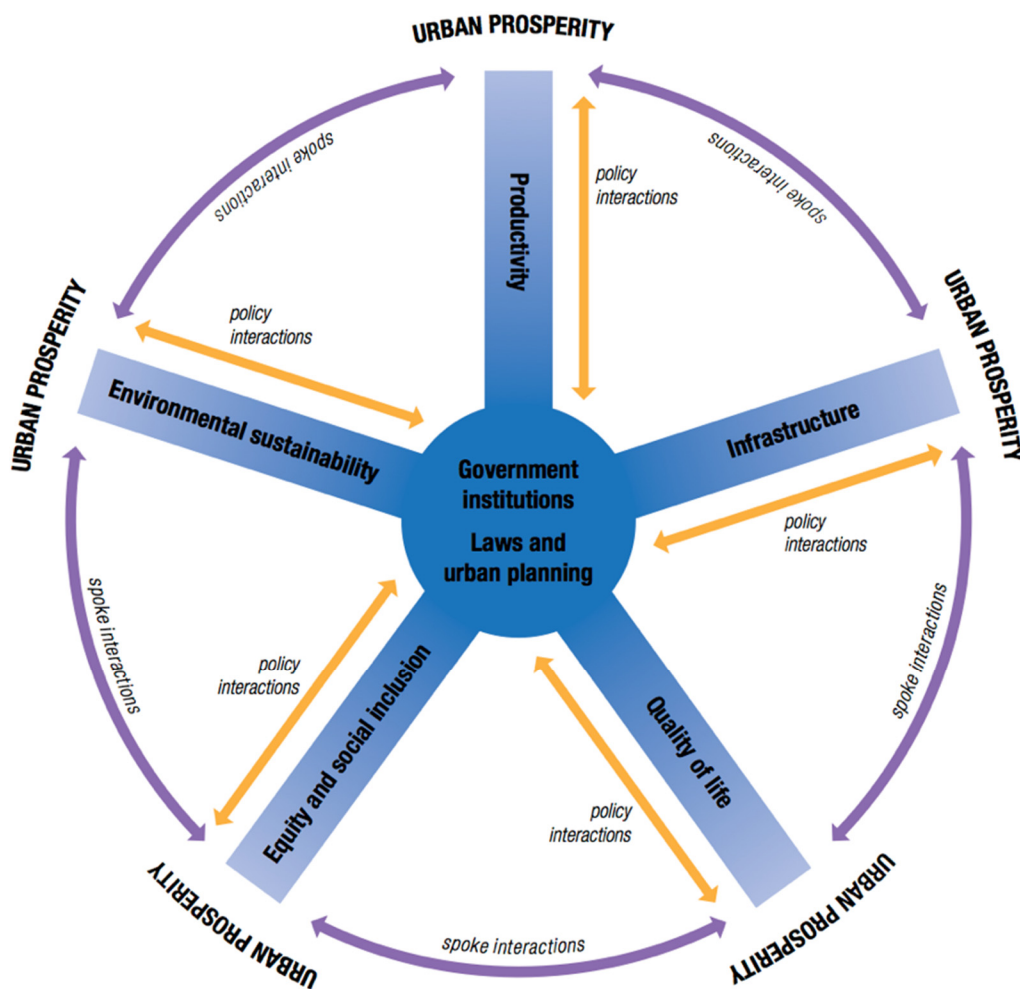
### UN-Habitat: City prosperity index

Source: UN-Habitat report "State of the World's cities 2012/2013 Prosperity of Cities"

(Table 1.1.3, p. 18)

<http://www.unhabitat.org/pmss/listItemDetails.aspx?publicationID=3387>

In the Wheel of Prosperity as defined by UN-Habitat, the "spokes" are the five dimensions of prosperity: productivity, infrastructure development, quality of life, equity and social inclusion, and environmental sustainability.



In the "City Prosperity Index", each dimension has its own index and it might be built up by a number of indices. The basic "City Prosperity Index" as reported in a publication consists of the following sub-indices and indicators:

**Table C.1 – City Prosperity Index**

Dimension	Definition/variables
Productivity	The productivity index is measured through the city product, which is composed of the variables capital investment, formal/informal employment, inflation, trade, savings, export/import, and household income/consumption. The city product represents the total output of goods and services (value added) produced by a city's population during a specific year.
Quality of life	The quality of life index is a combination of four sub-indices: education, health, safety/security and public space. The sub-index education includes literacy, primary, secondary and tertiary enrolment. The sub-index health includes life expectancy, under-five mortality rates, HIV/AIDS, morbidity and nutrition variables.
Infrastructure development	The infrastructure development index combines two sub-indices: one for infrastructure and another for housing. The infrastructure sub-index includes: connection to services (piped water, sewage, electricity and ICT), waste management, knowledge infrastructure, health infrastructure, and transport and road infrastructure. The housing sub-index includes building materials and living space.
Environmental sustainability	The environmental sustainability index is made of four sub-indices: air quality (PM10), CO <sub>2</sub> emissions, energy and indoor pollution.
Equity and social inclusion	The equity and social inclusion index combines statistical measures of inequity of income/consumption (Gini coefficient) and social and gender inequity of access to services and infrastructure.

There is also an extended "City Prosperity Index" with more indicators and a plan to include governance as a sixth dimension. Furthermore, a specific work has been made on Streets as a driver for prosperity, available at:

<http://www.unhabitat.org/pmss/listItemDetails.aspx?publicationID=3513>.

## Annex D

### China Institute of Communications (CIC): Index system of smart city

Source: <http://www.china-cic.org.cn/english/index.htm>

The evaluation index system of a smart city includes four major indexes: the information infrastructure, smart applications, support system, and value implementation. These four major indexes form the evaluation system of a smart city with the guidance of other elements, such as the network infrastructure, the construction of public support service system, and smart application, reflecting the level of value implementation of a smart city.

The evaluation index system of a smart city can be divided into four dimensions, including 19 second-level indexes and 57 third-level indexes [1]. This index system comprehensively considers various aspects, such as the infrastructure development level of urban information network, comprehensive competitiveness, policies and regulations, green and low-carbon, and culture and technology. It also includes software conditions, such as the intelligent transport administration, the medical education system, the capability of environmental protection network and industrial sustainable development, and the cultural and scientific quality of citizens. This system can embody and index the abstract smart city, forming a distinct guidance, ensuring a more efficient urban administration, a more liveable urban environment, and a continuously increasing happiness index of residents.

**Table D.1 – Evaluation index system of SSC**

No.	First-level index	Second-level index	Third-level index
1	Information infrastructure	Network infrastructure	Coverage rate of FTTx
			Coverage rate of wireless networks
			Household network bandwidth on average
			Penetration rate of broadband users
			Coverage rate of mobile phones
			Penetration rate of 3G users
		Cloud platform	Percentage of serving enterprises
			Industrial output of cloud computing
		Information security	Physical safety index
			Data safety index



**Table D.1 – Evaluation index system of SSC**

No.	First-level index	Second-level index	Third-level index
2	Smart applications	Smart e-government	Penetration rate of government online services
			Support degree of information resource on decision-making
			Percentage of online administration in the overall amount of work
			Increasing rate of the public basic satisfaction of the government work
		Smart transport	Capability of traffic information administration and service
			Installation rate of smart sensing terminals
		Smart logistics	Usage rate of informatization in logistics companies
			Percentage of e-commerce transaction amount in logistics
			Usage rate of RFID tags in items
		Smart tourism	Application level of telecommunication and information technologies
			Integration and sharing level of tourism
		Smart energy	Reliability of energy utilization
			Usage efficiency of energy
			Application level of new energies
		Smart building	Application level of information networks
			Application level of environmental protection and energy saving technologies
		Smart environmental protection	Proportion of automated inspection on environmental quality
			Proportion of significant pollution source monitoring
		Smart medical care	Percentage of archiving electronic health records for residents
			Usage rate of electronic medical records
			Sharing rate of resource and information among hospitals
		Smart education	Sharing level of educational resource
			Level of optimization in the course of education
			Promotion level of educational quality and benefits
Smart home	Percentage of smart home installation		
	Interaction rate of home informatization		
	Expenses of home informatization		

**Table D.1 – Evaluation index system of SSC**

No.	First-level index	Second-level index	Third-level index
3	Support system	Policies and regulations	Complete rate of policies and regulations
			Guidance capability of policies and regulations
		Specifications and standards	Complete rate of information standards
			Complete rate of equipment standards
			Complete rate of technical standards
		Personnel training	Proportion of related publicity and training personnel in overall population
			Quantity of employees in smart industries
			Percentage of population with college degrees or higher in total population
		4	Value implementation
Proportion of digital energy saving in buildings			
Declining rate of energy consumption per ten thousand Ren Min Bi (RMB) of GDP			
Liveable city (managing more efficiently)	Satisfaction degree of network resources		
	Convenience degree of traffic information access		
	Convenience degree of government services		
	Convenience degree of urban medical care		
	Convenience degree of educational resource access		
Safe city (live better)	Satisfaction degree in food safety		
	Satisfaction degree in environmental safety		
	Satisfaction degree in traffic safety		
	Satisfaction degree in prevention and control of crime and security		

## Annex E

### China, Ministry of Housing and Urban-Rural Development (MOHURD): Index system of national pilot smart city

Source: Ministry of Housing and Urban-Rural Development, China

MOHURD published the evaluation index system of the national pilot smart city in January 2013, which can be divided into four dimensions, including 11 second-level indexes and 57 third-level indexes. Each third-level index has been defined and has an indicator [3].

**Table E.1 – Evaluation index system of MOHURD**

First-level index	Second-level index	Third-level index	
Guarantee system and infrastructure	Guarantee system	Smart city plan and implementation scheme	
		Organization guarantee	
		Policy and regulation	
		Budget and sustainability	
		Operation and management	
	Network infrastructures	Wireless network	
		Broadband network	
		Next-generation broadcasting network	
	Public platform and database	Public database	
		Public platform	
		Information security	
	Smart construction and liveability	City construction management	Urban and rural planning
			Digital city management
Construction market management			
Real estate management			
Horticulture			
Historic heritage protection			
Building energy saving			
Green building			

First-level index	Second-level index	Third-level index
	Functional improvement of city	Waterworks
		Drainage system
		Water saving application
		Gas system
		Garbage classification and disposal
		Heat supply system
		Lighting system
		Underground pipelines and spatial integrated administration
Smart governance and service	Governance service	Decision-making support
		Open information
		Online service
		Governance service integrated system
	Basic public services	Basic public education
		Employment services
		Social insurance
		Social services
		Health care
		Public culture and sports
		Service for the handicapped
		Basic housing guarantee
	Application service	Intelligent transport system (ITS)
		Smart energy
		Smart environmental protection
		Smart land resource administration
		Smart emergency response

First-level index	Second-level index	Third-level index
		Smart safety
		Smart logistics
		Smart community
		Smart housing
		Smart payment
		Smart finance
Smart industry and economy	Industry planning	Industry planning
		Innovation investment
	Industry upgrading	Industrial factors agglomeration
		Traditional industry upgrading
	Development of emerging industry	Hi-tech industry
		Modern service industry
		Other emerging industry

## Annex F

### EU: European common indicators

Source: European Commission, [http://ec.europa.eu/environment/urban/common\\_indicators.htm](http://ec.europa.eu/environment/urban/common_indicators.htm)

Ambiente Italia (2003), European Common Indicators – Towards a local sustainability profile, final project report, 2003. [http://www.cityindicators.org/Deliverables/eci\\_final\\_report\\_12-4-2007-1024955.pdf](http://www.cityindicators.org/Deliverables/eci_final_report_12-4-2007-1024955.pdf)

The European Common Indicators (ECI) project was an EU project with the subtitle "Towards a Local Sustainability Profile" finalized in 2003, which developed an indicator system and collected data for cities from 14 different countries. Data and information from 42 urban areas was processed in the project. Ten indicators were listed and matched towards six different sustainability principles.

The six sustainability principles were:

1. Equality and social inclusion (access for all to adequate and affordable basic services, e.g. education, employment, energy, health, housing, training, transport);
2. Local governance/empowerment/democracy (participation of all sectors of the local community in local planning and decision-making processes);
3. Local/global relationship (meeting local needs locally, from production to consumption and disposal, meeting needs that cannot be met locally in a more sustainable way);
4. Local economy (matching local skills and needs with employment availability and other facilities, in a way that poses minimum threat to natural resources and the environment);
5. Environmental protection (adopting an ecosystem approach, minimizing the use of natural resources and land, generation of waste and emission of pollutants, enhancing biodiversity);
6. Cultural heritage/quality of the built environment (protection, preservation and rehabilitation of historic, cultural and architectural values, including buildings, monuments, events, enhancing and safeguarding attractiveness and functionality of spaces and buildings).

For an indicator to be accepted, it should meet at least three of the principles. Indicators are shown in the figure below. Each indicator is described in methodological sheets in the reference and a list of the indicators is given below.



**Table F.1 – Principles of European Common Indicators**

Towards a Local Sustainability Profile European Common Indicators		Principle n°					
n°	Issue/Indicator	1	2	3	4	5	6
1	Citizens' Satisfaction with the Local Community	✓	✓		✓	✓	✓
2	Local Contribution to Global Climate Change (and/or local Ecological Footprint)	✓		✓	✓	✓	
3	Local Mobility and Passenger Transportation	✓		✓	✓	✓	✓
4	Availability of Local Public Open Areas and Services	✓		✓		✓	✓
5	Quality of Local Air	✓				✓	✓
6	Children's Journeys to and from School	✓		✓	✓	✓	
7	Sustainable Management of the Local Authority and Local Businesses			✓	✓	✓	
8	Noise Pollution	✓				✓	✓
9	Sustainable Land Use	✓		✓		✓	✓
10	Products Promoting Sustainability	✓		✓	✓	✓	

**Table F.2 – List of European Common Indicators**

Cell Contents (EF values)	Modifier 1 (Front page)	Modifier 2 (Assumptions page)
<b>ENERGY LAND</b>		
<b>Nourishment</b> Food embodied energy	Food consumption kg/cap	Energy coefficient GJ/ton  Carbon intensity ton C/GJ
<b>Shelter</b> Domestic electricity Domestic natural gas & LPG Domestic oil District heating Domestic Coal Renewable (wood excluded) Other domestic	Energy consumption kWh/cap kWh/cap kWh/cap kWh/cap kWh/cap kWh/cap kWh/cap	Carbon intensity kg C/kWh kg C/kWh kg C/kWh kg C/kWh kg C/kWh kg C/kWh kg C/kWh
<b>Mobility</b> Car Bus & coach Rail, tram, metro Waterborne Air Motorbike/scooters	Distance covered passenger-km/cap passenger-km/cap passenger-km/cap passenger-km/cap passenger-km/cap (intra EU only*) passenger-km/cap	CO <sub>2</sub> emissions kg CO <sub>2</sub> / passenger-km kg CO <sub>2</sub> / passenger-km kg CO <sub>2</sub> / passenger-km kg CO <sub>2</sub> / passenger-km kg CO <sub>2</sub> / passenger-km kg CO <sub>2</sub> / passenger-km
<b>Goods &amp; Services</b> Net traded goods Local goods  Hotels & restaurants Community, social, personal Offices & admin Commerce Other services Education & health	Domestic waste kg/cap (landfill and incinerated) kg/cap (landfill and incinerated)  Services spending Euro/cap Euro/cap Euro/cap Euro/cap Euro/cap None	

Cell Contents (EF values)	Modifier 1 (Front page)	Modifier 2 (Assumptions page)
<b>CROP</b>		
<b>Nourishment</b>	Food consumption	Kind of diet
Animal-based	kg/cap	Proportion of animal products in diet (difference from national average)
Plant-based	kg/cap	Proportion of plant-based products in diet (difference from national average)
<b>Goods &amp; services</b>	Domestic waste	
	kg/cap (landfill and incinerated)	
<b>PASTURE</b>		
<b>Nourishment</b>	Food consumption	Kind of diet
Animal-based	kg/cap	Proportion of animal products in diet (difference from national average)
<b>Goods &amp; services</b>	Domestic waste	
	kg/cap (landfill and incinerated)	
<b>FOREST</b>		
<b>Shelter</b>	Fuelwood consumption	
	m <sup>3</sup> /cap	
<b>Goods &amp; services</b>	Wood products consumption	
	m <sup>3</sup> /cap	
<b>BUILT LAND</b>		
<b>Shelter</b>	Housing land	
	Actual area (ha)	
<b>Mobility</b>	Land for infrastructures	
Road	Road land – actual area (ha)	
Rail	Rail land – actual area (ha)	
Air	Airport land – actual area (ha)	
Ports	Sea ports land – actual area (ha)	
<b>Goods &amp; Services</b>	Land used	
	Goods & services land (including Hydro) – actual area (ha)	
<b>FISHING</b>		
<b>Nourishment</b>	Food consumption	Kind of diet
	kg/cap	Proportion of animal products in diet (difference from national average)
<b>Goods &amp; Services</b>	Domestic waste	
	kg/cap (landfill and incinerated)	

## Annex G

### Italy: Index system of smart city and smart statistics

Source:

FG-SSC-I-0058, Smart Cities and Smart Statistics

FG-SSC-I-0076, Proposal from Italy on document SSC-0057-rev-1

FG-SSC-I-0116, Proposal of indicators for Working Group 3 (WG3)

The six main dimensions of development are the following:

**1 – Economy:** The ability to create employment, the presence of innovative companies, good quality universities and advanced research institutes, and advanced telematics infrastructure.

**2 – Environment:** The intelligent use of resources promoting a sustainable development based on recycling and waste reduction, adopting rational building criteria, and protecting and managing urban green areas.

**3 – Governance:** The adoption of policies for boosting territorial development and inter-municipal networking capacity can enable a city to involve its citizens in issues of public importance, promote awareness and use technologies to digitize and simplify administrative procedures.

**4 – Living:** Advanced services for improving the quality of life (home care, childcare, aged care facilities) can enable a city to promote its own tourist image with intelligent online promotion (city routes and thematic maps).

**5 – Mobility:** A city where it is easy to get from one place to another, with an innovative and efficient system of public transport that promotes the use of vehicles with low environmental impact, which regulates access to historic town centres, and makes them more liveable (pedestrian walkways).

**6 – People:** The citizens of a city are active and participate in public life, and where a city can maximize its social capital and foster peaceful coexistence.

Smart sustainable city can be analysed through the six dimensions described above. A synthetic index of a smart sustainable city is as follows:

- *sscSupply*: Smart and sustainable services provided by the city;
- *sscUse*: Usage of smart services by the citizens;
- *sscNet*: Extent of smart services in the city area;
- *sscDE*: Level of degree of expertise of "smart citizens";
- *sscIndex*: Synthetic index that combine the four KPIs (*sscSupply*, *sscUse*, *sscNet*, and *sscDE*).

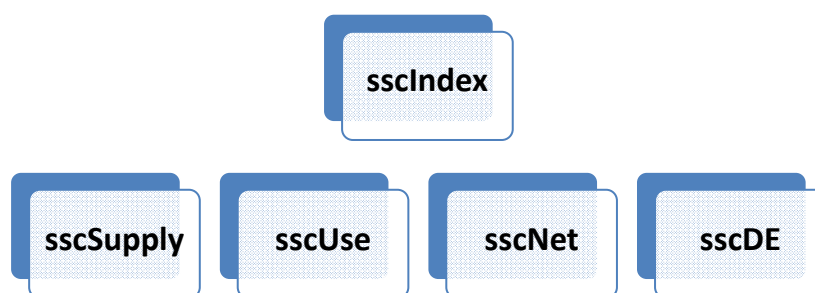

**Figure G.1 – Cities' KPI**

Figure G.1 shows the four indicators and the smart sustainable city global indicator (ssclIndex). Table G.1 shows in details the KPIs of a smart city for each dimension.

**Table G.1 – Cities' KPIs**

Level	KPIs			
City	sscSupply	sscUse	sscNet	sscDE
1– Economy	1.1 ecoSupply	1.2 ecoUse		
2– Environment	2.1 envSupply	2.2 envUse		
3– Governance	3.1 govSupply	3.2 govUse		
4– Living	4.1 livSupply	4.2 livUse		
5– Mobility	5.1 mobSupply	5.2 mobUse		
6– People	6.1 peoSupply	6.2 peoUse		

Table G.2 shows in details the indicators for building the "Supply" and "Use" KPIs for the six dimensions.

**Table G.2 – Indicators for "Supply" and "Use" KPIs**

Dimension	KPI	Indicator
1. Economy	1.1 ecoSupply	1.1.1 Percentage of ICT companies in GDP* 1.1.2 Ratio of patents per 1 million inhabitants* 1.1.3 Number of top R&D centres/universities* 1.1.4 Average available of mobile broadband bandwidth per urban resident*
	1.2 ecoUse	1.2.1 Percentage of workers in ICT companies 1.2.2 Percentage of graduates at top universities 1.2.3 Ratio of contracts in broadband (per 1,000 inhabitants)

**Table G.2 – Indicators for "Supply" and "Use" KPIs**

Dimension	KPI	Indicator
2. Environment	2.1 envSupply	2.1.1 Ratio of smart buildings for 1,000 urban resident* 2.1.2 Percentage of waste disposal recycling 2.1.3 Ratio of days of healthy air breathing within a year (index of quality of air)* 2.1.4 Amount of CO <sub>2</sub> emission per capita (CO <sub>2</sub> released to the atmosphere from factories, vehicles, draught animals raised for food per capita)*
	2.2 envUse	2.2.1 Level of energy saving technologies (degree of energy efficient technologies applied in all the services and industries, including solar power, electric vehicles, energy conservation electric appliances, etc.)* 2.2.2 Percentage of renewable energy sources (RES) on total consumption (solar, wind, tide power and so on)*
3. Governance	3.1 govSupply	3.1.1 Level of digital services provided by smart city (e.g.: fee payment for applications on mobile phones or via the web) 3.1.2 Level of emergency warning systems (through mobile phones and online) 3.1.3 Level of decision-making online system offered by the city (e.g.: polls, referendums, etc.)*
	3.2 govUse	3.2.1 Percentage of citizens who use digital services (e.g.: fee payment for applications on mobile phones or via the web) 3.2.2 Percentage of citizens' participation in online decision-making (through polls, referendums, etc.)*
4. Living	4.1 livSupply	4.1.1 Level of health centres (hospitals, pharmacies, general practitioners (GPs), paediatricians, etc.) with archiving electronic health records (EHRs)* 4.1.2 Level of telemedicine services offered by the city (e.g.: telemonitoring, teleconsultation, telerehabilitation, etc.) 4.1.3 Level of digital schools (Internet, digital boards, etc.) 4.1.4 Average amount of leisure for inhabitant
	4.2 livUse	4.2.1 Ratio of patients with electronic health records (per 1,000 patients)* 4.2.2 Ratio of patients enrolled in programmes of telemedicine services (per 1,000 patients) 4.2.3 Percentage of students enrolled in digital schools
5. Mobility	5.1 mobSupply	5.1.1 Level of teleworking in public administration 5.1.2 Level of integrated digital system for mobility
	5.2 mobUse	5.2.1 Ratio of people using the teleworking system (per 1,000 workers) 5.2.2 Percentage of citizens using digital mobility information system
6. People	6.1 peoSupply	6.1.1 Level of online interaction between residents and municipality 6.1.2 Level of digital universities (e.g.: online courses, etc.)
	6.2 peoUse	6.2.1 Ratio of people using the e-learning system (per 1,000 citizens)* 6.2.2 Percentage of students enrolled in digital universities

\* Indicates the reference in FG-SSC-0094-r1 proposed by Fiberhome Technologies Group.



Table G.3 shows in details the indicator for building the "Net" and "DE" KPIs for smart city.

**Table G.3 – Indicators for "Net" and "DE" KPIs**

	KPI	Indicator
City	sscNet	0.3.1 Percentage of buildings covered by fixed broadband (or percentage of city area covered by broadband) 0.3.2 Percentage of city area covered by mobile broadband 0.3.3 Percentage of public offices integrated into the network (sharing data, notification of significant events, consultation, etc.) 0.3.4 Percentage of online administrative services (digital certificates, administrative judicial, etc.)
	sscDE	0.4.1 Percentage of citizens with Internet access 0.4.2 Percentage of citizens with certified e-mail 0.4.3 Percentage of citizens with digital signature 0.4.4 Percentage of citizens with computer driving licenses (such as a European computer driving license (ECDL), computer science courses, etc.) 0.4.5 Percentage of citizens who use regularly Internet for purchases, payments, reservations (at least once a month)

## Annex H

### Japan: Index system of SSC being discussed in the sub working group for SSC of the Telecommunication Technology Committee (TTC)

Source: Telecommunication Technology Committee, Japan

<http://www.ttc.or.jp/e/>

Structure of KPI [8]:

The Telecommunication Technology Committee (TTC) in Japan has formed a sub working group for SSC meetings to discuss the index system of SSC.

With the proposed KPIs of SSC [8], indicators are divided into four layers for simplicity, and positioned "environment, economy, society, satisfaction" as the first layer. Since the notion of "society" is broad, it is further split into "safety", "health", and "comfort," then positioned in the second layer. The third layer includes indicators such as "information security" and "ubiquitous" from the ICT perspective. The fourth layer includes data to calculate the KPIs in the third layer. The main feature of the KPIs is that various units are used for data in the fourth layer as indicated in Table H.1, while all other layers use a monetary value as the unit.

**Table H.1 – Structure of KPIs**

KPI layers				Notes	
First layer [unit: monetary value] *	Second layer [unit: monetary value]*		Third layer [unit: monetary value] *		Fourth layer (example) [unit: monetary value, %, time, weight, etc.]
Environment	Environment	Less environmental impact	Environment/natural resource	Amount of CO2 emission, waste, resource depletion (water, underground resources, etc.), toxic substance, biodiversity	Perspective of the policy implementing-side (operator-side) and subject-side (citizens-side)
			Energy	Resource depletion, the amount of consumption, sustainability of electricity supply, utilization rate of renewable energy	
Economy	Economy	High cost performance	Cost performance	Cost: deployment/ operation/maintenance Benefit: financial effect/ profit/ employment rate/ enterprising rate/ online billing rate	Perspective of the policy implementing-side (operator-side)
Society	Safety	Less damage on people and their properties	Accident	Accident rate (victim, damaged object), damage cost	Perspective of the subject-side (citizens-side) * Select or define according to the goal of SCC (advanced country/ developing country, urban area/ rural area, etc.)
			Natural disaster	Damage rate (victim, damaged object), damage cost	
			Crime	Damage rate (victim, damaged object), damage cost	
			Information security	Information accessibility, information leakage rate, information importance, damage cost	
	Health	People staying healthy	Health management	Sporting ability level, nursing care cost, social security cost	
			Prevention of illness	Morbidity (incidence rate, prevalence, fatality rate), medical expense	
			Medical treatment	Mortality, morbidity, medical expense	
			Stress	Morbidity, medical expense	
	Comfort	Comfortable living	Diverse opportunities	Labor force participation rate, number of tourists, frequency of visit, purchase rate, leisure time, means of transportation	
			Barrier free	Usage ratio (number of people, frequency), composition of users	
			simplicity	Usage ratio (number of people, frequency) willingness to use, satisfaction level with equipment	
			Ubiquitous	Service area, service duration, device penetration ratio	
Satisfaction	Satisfaction	Satisfaction with the life	Citizens' degree of satisfaction	Willingness to pay	

\* Indicates using a monetary value as the unit.

### **Fujitsu's practice on Evaluation Method regarding Value and Environmental Impact of Cities**

Fujitsu presently published an article "Development of Quantitative Evaluation Method regarding Value and Environmental Impact of Cities" based on its experiences to participate in the planning and building of SSCs in various regions of Japan. It intends to evaluate both the value and environmental impact of ICT solutions in cities as a whole and to achieve a balance between ease of living, economic growth and environmental considerations.

The URL of the article is "<http://www.fujitsu.com/downloads/MAG/vol50-2/paper13.pdf>"

## Annex I

## GCIF: Global city indicators facility

Source: Global city indicators, <http://www.cityindicators.org/>

The global city indicators facility (GCIF) provides an established set of city indicators claiming to use a globally standardized methodology that allows for global comparability of city performance and knowledge sharing. City services are divided into education, electricity, finance, recreation, fire and emergency response, governance, health, safety, solid waste, transport, urban planning, wastewater, and water. Quality of life factors are: civic engagement, culture, economy, environment, shelter, social equity, technology and innovation.

Table I.1 – Profile indicators

Profile indicators list	
	Indicators
People	Total city population
	Population density (per square kilometre)
	Percentage of country's population
	Percentage of population that are children (0-14)
	Percentage of population that are youth (15-24)
	Percentage of population that are adult (25-64)
	Percentage of population that are senior citizens (65+)
	Male to female ratio (# of males per 100 females)
	Annual population change
	Population dependency ratio
	Percentage of population that are new immigrants
	Percentage of population that are migrating from elsewhere in the country
	Housing
Total number of occupied dwelling units (owned and rented)	
Persons per unit	
Dwelling density (per square kilometre)	
Economy	Average household income (USD)
	Annual inflation rate based on average of last five years
	Cost of living
	Income distribution (Gini coefficient)
	Country's GDP (USD)
	Country's GDP per capita (USD)
	City product (USD)
	City product as a percentage of country's GDP
	Total employment
	Employment percentage change based on the last five years

Profile indicators list	
	Indicators
	Number of businesses per 1,000 Population
	Annual average unemployment rate
	Commercial/industrial assessment as a percentage of total assessment
<b>Government</b>	Type of government (e.g. local, regional, county)
	Gross operating budget (USD)
	Gross operating budget per capita (USD)
	Gross capital budget (USD)
	Gross capital budget per capita (USD)
<b>Geography and climate</b>	Region
	Climate Type
	Land area (square kilometres)
	Percentage of non-residential area (square kilometres)
	Annual average temperature (Celsius)
	Average annual rain (mm)
	Average annual snowfall (cm)

**Table I.2 – City services and quality of life indicators**

Performance indicators list		
City services	Core indicator	Supporting indicator
<b>Education</b>	Student/teacher ratio	Percentage of school-aged population enrolled in schools
	Percentage of students completing primary and secondary education: survival rate	Percentage of male school-aged population enrolled in schools
	Percentage of students completing primary education	Percentage of female school-aged population enrolled in schools
	Percentage of students completing secondary education	
<b>Fire and emergency response</b>	Number of fire-fighters per 100,000 population	Response time for fire department from initial call
	Number of fire related deaths per 100.000 population	
<b>Health</b>	Number of in-patient hospital beds per 100.000 population	Number of nursing and midwifery personnel per 100.000 population
	Number of physicians per 100,000 population	
	Average life expectancy	
	Under age five mortality per 1,000 live births	

Performance indicators list		
City services	Core indicator	Supporting indicator
Recreation		Square meters of public indoor recreation space per capita
		Square meters of public outdoor recreation space per capita
Safety	Number of police officers per 100,000 population	Violent crime rate per 100,000 population
	Number of homicides per 100,000 population	
Solid waste	Percentage of city population with regular solid waste collection	Percentage of the city's solid waste that is disposed of in an incinerator
	Percentage of city's solid waste that is recycled	Percentage of the city's solid waste that is burned openly
		Percentage of the city's solid waste that is disposed of in an open dump
		Percentage of the city's solid waste that is disposed of in a sanitary landfill
		Percentage of the city's solid waste that is disposed of by other means
Transport	Km of high capacity public transit system per 100,000 population	Number of two-wheel motorized vehicles per capita
	Km of light passenger transit system per 100,000 population	Commercial air connectivity (number of non-stop commercial air destinations)
	Number of personal automobiles per capita	Transport fatalities per 100,000 population
	Annual number of public transit trips per capita	
Wastewater	Percentage of city population served by water collection	Percentage of the city's wastewater receiving primary treatment
	Percentage of the city's wastewater that has received no treatment	Percentage of the city's wastewater receiving secondary treatment
		Percentage of the city's wastewater receiving tertiary treatment
Water	Percentage of city population with potable water supply service	Total water consumption per capita (litres/day)
	Domestic water consumption per capita (litres/day)	Percentage of water loss
	Percentage of city population with sustainable access to an improved water source	Average annual hours of water service interruption per household



Performance indicators list		
City services	Core indicator	Supporting indicator
<b>Electricity</b>	Percentage of city population with authorized electrical service	Total electrical use per capita (kWh/year)
	Total residential electrical use per capita (kWh/year)	The average number of electrical interruptions per customer per year
	Average length of electrical interruptions (in hours)	
<b>Finance</b>	Debt service ratio (debt service expenditure as a percent of a municipality's own-source revenue)	Tax collected as percentage of tax billed
	Own-source revenue as a percentage of total revenues	
	Capital spending as a percentage of total expenditures	
<b>Governance</b>	Percentage of women employed in the city government workforce	
<b>Urban planning</b>	Jobs/housing ratio	Areal size of informal settlements as a percent of city area
	Green area (hectares) per 100,000 population	

Quality of life	Core indicator	Supporting indicator
<b>Civic engagement</b>	Voter participation in last municipal election (as a percent of eligible voters)	Citizen's representation: number of local officials elected to office per 100,000 population
<b>Culture</b>		Percentage of jobs in the cultural sector
<b>Economy</b>	City product per capita	Percentage of persons in full time employment
	City unemployment rate	
<b>Environment</b>	PM10 concentration	Greenhouse gas emissions measured in tonnes per capita
<b>Shelter</b>	Percentage of city population living in slums	Percentage of households that exist without registered legal titles
		Number of homeless people per 100,000 population
<b>Social equity</b>		Percentage of city population living in poverty

Quality of life	Core indicator	Supporting indicator
<p style="text-align: center;"><b>Technology and innovation</b></p>	<p>Number of Internet connections per 100,000 population</p>	<p>Number of new patents per 100,000 population per year</p>
		<p>Number of higher education degrees per 100,000 population</p>
		<p>Number of telephone connections (landlines and cell phones) per 100,000 population</p>
		<p>Number of landline phone connections per 100,000 population</p>
		<p>Number of cell phone connections per 100,000 population</p>

## Annex J

### ICLEI: Global protocol for community scale GHG emissions (GPC)

Source: ICLEI, <http://www.iclei.org/details/article/global-protocol-for-community-scale-ghg-emissions-gpc.html>

The Global Protocol for Community scale GHG emissions (GPC) was developed by ICLEI and C40 and supported by the World Bank, UN-Habitat and others.

In GPC, the emissions summing up to the total community emissions are divided into sectors and subsectors, see below. For each subsector, direct emissions (scope 1) and indirect emissions (scope 2) should be reported. In addition, communities are asked to report direct emissions accounted for elsewhere and scope 3 emissions related to main sectors.

**Table J.1 – Sector/Subsector of GPC**

Sector	Subsector
Stationary units	Residential, commercial/industrial facilities, energy generation, and industrial energy use as subsectors.
Mobile units	On-road transportation (cars, light duty vehicle (LDV), heavy duty vehicle (HDV), buses, others), railways (including urban metro/rail transport system), water-borne navigation, aviation, off-road.
Waste	Solid waste, biological treatment of waste, waste incineration and open burning, wastewater treatment and discharge.
IPPU	Industrial processes and product uses.

This protocol is a development of the international local government GHG emissions analysis protocol (IEAP) published by ICLEI in 2009 (international local government GHG emissions analysis protocol (IEAP), version 1.0. October 2009, available at [http://carbons.org/fileadmin/user\\_upload/carbons/Standards/IEAP\\_October2010\\_color.pdf](http://carbons.org/fileadmin/user_upload/carbons/Standards/IEAP_October2010_color.pdf) ). The IEAP consists of principles that should be adhered to when inventorying GHG emissions from a community.

**Table J.2 – Protocol of GPC**

UNFCCC Sector		Scope 1 Emissions	Scope 2 Emissions	Scope 3 Emissions
Energy	Stationary Energy	Utility-delivered fuel consumption Decentralized fuel consumption Utility-consumed fuel for electricity / heat generation	Utility-delivered electricity / heat / steam cooling consumption Decentralized electricity / heat / steam consumption	Upstream/downstream emissions (e.g., mining/transport of coal)
	Transport	Tailpipe emissions from on-road vehicles Tailpipe emissions from rail, sea, airborne and non-road vehicles operating within the community	Electricity consumption associated with vehicle movement within the community (e.g., light rail)	Tailpipe emissions from vehicles used by community residents Upstream/downstream emissions (e.g., mining/transport of oil) Tailpipe emissions from rail, sea, and airborne vehicles departing from or arriving into the community
	Fugitive Emissions	Fugitive emissions not already accounted for	n/a	Upstream/downstream emissions
Industrial Processes		Decentralized process emissions	n/a	Upstream/downstream emissions
Agriculture		Emissions from livestock and managed soils	n/a	Upstream/downstream emissions from fertilizer/pesticide manufacture
Land Use, Land Use Change and Forestry		Net biogenic carbon flux	n/a	n/a
Waste	Solid Waste Disposal	Direct emissions from landfill, incineration and compost facilities located inside the community	n/a	Landfill, incineration and compost emissions in present-year from waste produced to date inside the community Future emissions from waste disposed
	Wastewater Treatment and Discharge	Direct emissions from wastewater facilities located inside the community	n/a	Present-year emissions from wastewater produced to date inside the community Future emissions from treated wastewater

## Annex K

## ESCI: Indicators of the emerging and sustainable cities initiative

Source: Inter-American Development Bank,

<http://www.iadb.org/en/topics/emerging-and-sustainable-cities/implementing-the-emerging-and-sustainable-cities-initiative-approach,7641.html>

The emerging and sustainable cities initiative (ESCI) was created by the Inter-American Development Bank (IDB) in 2010 in response to rapid and largely unregulated urbanization in the Latin American and Caribbean (LAC) region, and the resulting urgent need to deal with the sustainability issues faced by the region's rapidly growing intermediate-size cities. It addresses three dimensions of sustainability: environmental sustainability and climate change, urban sustainability, and fiscal sustainability and governance.

**Table K.1 – indicators of environmental sustainability and climate change of ESCI**

I. Environmental sustainability and climate change			
#Topics	#Subtopic	#Indicator	#Unit of measurement
A. Water	A.1 Water coverage	1. Percentage of households with home connections to the city's water network	%
	A.2 Efficiency in the use of water	2. Annual water consumption per capita	L/person/day
		A.3 Efficiency in the water supply service	3. Continuity of water service
	4. Water quality		%
	5. Non-revenue water		%
	A.4 Availability of water resources	6. Remaining number of years of a positive water balance	Years

I. Environmental sustainability and climate change			
#Topics	#Subtopic	#Indicator	#Unit of measurement
<b>B. Sanitation and drainage</b>	B.1 Sanitation coverage	7. Percentage of households with a home connection to the sewer system	%
	B.2 Wastewater treatment	8. Percentage of wastewater that is treated according to national standards	%
	B.3 Effectiveness of drainage	9. Percentage of dwellings damaged by the most intense flooding in the last 10 years	%
<b>C. Solid waste management</b>	C.1 Solid waste collection coverage	10. Percentage of population with regular municipal solid waste collection	%
	C.2 Adequate final disposal of solid waste	11. Percentage of the city's municipal solid waste disposed of in sanitary landfills	%
		12. Remaining life of the site where the landfill is located	Years
		13. Percentage of the city's municipal solid waste that is disposed of in open dumps, controlled dumps, or bodies of water or is burnt	%
	C.3 Treatment of solid waste	14. Percentage of the city's municipal solid waste that is composted	%
		15. Percentage of the city's municipal solid waste that is separated and classified for recycling	%
		16. Percentage of the city's municipal solid waste that is used as an energy resource	%
<b>D. Energy</b>	D.1 Energy coverage	17. Percentage of the city's households with an authorized connection to electrical energy	%
		18. Percentage of the city's households with an authorized connection to the network of natural gas supply	%
		19. Average number of electrical interruptions per year, per customer	#/yr/customer
		20. Average length of electrical interruptions	hr/customer



<b>I. Environmental sustainability and climate change</b>			
<b>#Topics</b>	<b>#Subtopic</b>	<b>#Indicator</b>	<b>#Unit of measurement</b>
	D.2 Energy efficiency	21. Total annual electrical consumption per residential household	kWh/household/yr
		22. Energy intensity of the economy	kg of oil equivalent per USD 1,000 GDP
		23. Existence, monitoring, and enforcement of energy efficiency regulations	Yes/No
	D.3 Alternative and renewable energy	24. Percentage of renewable energy in total energy generation	%
<b>E. Air quality</b>	E.1 Air quality control	25. Existence, monitoring, and enforcement of air quality regulations	Yes/No
	E.2 Concentration of pollutants in the air	26. Air quality index	#
		27. PM10 concentration	24-hour average PM10 in µg/m3
<b>F. Mitigation of climate change</b>	F.1 GHG emission measurement systems	28. Existence and monitoring of greenhouse gas inventory	Yes/No
	F.2 Total GHG emissions	29. Per capita greenhouse gas emissions	Annual tons of CO <sub>2</sub> e per capita
		30. Greenhouse gas emissions per GDP	kg/USD of GDP
	F.3 Mitigation plans and objectives	31. Existence of mitigation plans with reduction targets by sector and a monitoring system in place	Yes/No
<b>G. Noise</b>	G.1 Noise control	32. Existence, monitoring, and enforcement of regulations on noise pollution	Yes/No
<b>H. Vulnerability to natural disasters in the context of climate change</b>	H.1 Climate change adaptation capacity and extreme natural events	33. Existence of risk maps	Yes/No
		34. Existence of adequate contingency plans for natural disasters	Yes/No
		35. Existence of effective early warning systems	Yes/No
		36. Disaster risk management in city development planning	Yes/No
		37. Percentage of deliverables of the disaster risk management planning instruments that have been completed	Yes/No
		38. Budget allocation for disaster risk management	Yes/No

I. Environmental sustainability and climate change			
#Topics	#Subtopic	#Indicator	#Unit of measurement
	H.2 Sensitivity to natural disasters	39. Critical infrastructure at risk due to inadequate construction or placement in areas of non-mitigable risk	%
		40. Percentage of households at risk due to inadequate construction or placement in areas of non-mitigable risk	%

Table K.2 – indicators of urban sustainability of ESCI

II. Urban sustainability			
#Topics	#Subtopic	#Indicator	#Unit of measurement
I. Land use, planning, and zoning	I.1 Density	41. Annual growth rate of the urban footprint	% annual
		42. (Net) urban population density	Residents/km <sup>2</sup>
	I.2 Housing	43. Substandard housing	%
		44. Quantitative housing shortage	%
	I.3 Green and recreational areas	45. Green area per 100,000 residents	hectares/100,000 residents
		46. Public recreational area per 100,000 residents	hectares/100,000 residents
	I.4 Land use planning	47. Existence and active implementation of a land use plan	Yes/No and implementation
		48. Up-to-date, legally binding master plan	Yes to both criteria/ Yes to only one criterion/No to both criteria
J. Urban inequality	J.1 Poverty	49. Percentage of the population below the poverty line	%
	J.2 Socio-spatial segregation	50. Percentage of housing located in informal settlements	%
	J.3 Income inequality	51. Income Gini coefficient	
K. Mobility/ transportation	K.1 Balanced transportation infrastructure	52. Kilometres of road per 100,000 population	km
		53. Kilometres of roads dedicated exclusively to public transit per 100,000 population	km

II. Urban sustainability			
#Topics	#Subtopic	#Indicator	#Unit of measurement
		54. Kilometres of bicycle path per 100,000 population	km
		55. Kilometres of sidewalk and pedestrian path per 100,000 population	km
		56. Modal split (specifically public transport)	%
	K.2 Clean transportation	57. Average age of public transport fleet	Years
	K.3 Safe transportation	58. Transportation fatalities per 1,000 population	Deaths per 1,000 population
	K.4 Reduced congestion	59. Average travel speed on primary thoroughfares during peak hours	km/h
		60. Number of automobiles per capita	Vehicles per capita
	K.5 Planned and managed transportation	61. Transportation planning and management system	Yes/No
	K.6 Affordable transportation	62. Affordability index	%
	K.7 Balanced demand	63. Jobs-to-housing ratio	Ratio
<b>L. Competitiveness of the economy</b>	L.1 Regulation of business and investment	64. Days to obtain a business licence	# of days
	L.2 Strategic infrastructure	65. Existence of a logistics platform	Yes/No
	L.3 Gross product	66. GDP per capita of the city	USD per capita
<b>M. Employment</b>	M.1 Unemployment	67. Average annual unemployment rate	%
	M.2 Informal employment	68. Informal employment as a percentage of total employment	%
<b>N. Connectivity</b>	N.1 Internet	69. Fixed broadband Internet subscriptions per 100 inhabitants	# of subscriptions per 100 residents
		70. Mobile broadband Internet subscriptions per 100 inhabitants	# of subscribed mobile phones per 100 residents
	N.2 Telephones	71. Mobile cellular phone subscriptions per 100 inhabitants	# of subscriptions per 100 residents

II. Urban sustainability			
#Topics	#Subtopic	#Indicator	#Unit of measurement
O. Education	O.1 Quality of education	72. Adult literacy rate	%
		73. Percentage of students passing standardized reading tests	%
		74. Percentage of students passing standardized math tests	%
		75. Student-teacher ratio	Students/teachers
	O.2 Attendance	76. Percentage of three- to five-year-olds receiving comprehensive early childhood development services	%
		77. Percentage of six- to 11-year-olds enrolled in school	%
		78. Percentage of 12- to 15-year-olds enrolled in school	%
		79. Percentage of 16- to 18-year-olds enrolled in school	%
	O.3 Higher education	80. University seats per 100,000 people	# per 100,000 residents
	P. Security	P.1 Violence	81. Homicides per 100,000 residents
82. Prevalence of partner violence – last 12 months			%
83. Prevalence of partner violence – lifetime			%
84. Robberies per 100,000 residents			# every 100,000 residents
85. Larcenies per 100,000 residents			# every 100,000 residents
P.2 Citizens' confidence in security		86. Percentage of citizens who feel safe	%
		87. Victimization rate	%
Q. Health	Q.1 Level of health	88. Life expectancy at birth	Years
		89. Male life expectancy at birth	Years
		90. Female life expectancy at birth	Years
		91. Under-five mortality rate (per 1,000 live births)	Deaths/1,000 live births
	Q.2 Provision of health services	92. Doctors per 100,000 residents	Doctors/100,000 residents
		93. Hospital beds per 100,000 residents	Beds/100,000 residents

**Table K.3 – indicators of fiscal sustainability and government of ESCI**

III. Fiscal sustainability and government			
#Topics	#Subtopic	#Indicator	#Unit of measurement
<b>R. Participatory public management</b>	R.1 Citizen participation in planning of government's public management	94. Existence of a participatory planning process	Yes/Qualified, Yes/No
		95. Existence of participatory budgeting	Yes/No and % of the budget
	R.2 Public reporting	96. Public reporting sessions per year	#
<b>S. Modern public management</b>	S.1 Modern processes of public management of the municipal budget	97. Existence of a multi-annual budget	Yes/No and years
		98. Remuneration of personnel based on a system of performance indicators	Yes/No and % of personnel
	S.2 Modern systems of public management of the municipal government	99. Existence of electronic systems for tracking the municipality's management	Yes, electronic/ Yes, manual/ No
		100. Existence of electronic procurement system	Yes/Qualified, Yes/No
<b>T. Transparency</b>	T.1 Transparency and auditing of the government's public management	101. Transparency index	#
		102. Municipal government accounts audited	%
		103. Municipal companies' accounts audited by a third party	%
<b>U. Taxes and financial autonomy</b>	U.1 Municipal revenue and taxes	104. Own-source revenue as a percentage of total revenue	%
		105. Total transfers as a percentage of total revenue	%
		106. Earmarked transfers as a percentage of total transfers	%
		107. Revenue from other sources (external donors) as a percentage of total revenue	%
	U.2 Collection management	108. Utility cost recovery	%
		109. Taxes collected as a percentage of taxes billed	%

III. Fiscal sustainability and government			
#Topics	#Subtopic	#Indicator	#Unit of measurement
<b>V. Expenditure management</b>	V.1 Quality of public spending	110. Performance indicators and goals for tracking budget execution	Yes/No
		111. Gross operating budget (current expenditure as percentage of total expenditures)	%
		112. Gross capital budget (capital expenditure as percentage of total expenditures)	%
		113. Annual growth rate of current expenditure	% annual
		114. Budget's alignment with plan	Yes/No
<b>W. Debt</b>	W.1 Contingent liabilities	115. Contingent liabilities as a percentage of own revenue	%
	W.2 Sustainability of municipal debt	116. Debt service ratio	%
		117. Debt growth	%



## Annex L

### Vienna University of Technology: European ranking of medium-sized cities

Source: Vienna University of Technology, |  
[http://www.smart-cities.eu/download/smart\\_cities\\_final\\_report.pdf](http://www.smart-cities.eu/download/smart_cities_final_report.pdf)

The ranking has six characteristics (smart economy, smart mobility, smart environment, smart people, smart living, smart governance), 31 factors, and 74 indicators [4]. (ERMC)

**Table L.1 – indicators of European ranking of medium-sized cities**

Characteristics	Factors	Indicators
Smart economy	Innovative spirit	R&D expenditure in % of GDP
		Employment rate in knowledge-intensive sectors
		Patent applications per inhabitant
	Entrepreneurship	Self-employment rate
		New business registered
	Economic image and trademarks	Importance as decision-making centre (HQ, etc.)
	Productivity	GDP per employed person
	Flexibility of labour market	Unemployment rate
		Proportion in part-time employment
	International embeddedness	Companies with HQ in the city quoted on national stock market
Air transport of passengers		
Air transport of freight		
<i>Ability to transform</i>	0	
Smart mobility	Local accessibility	Public transport network per inhabitant
		Satisfaction with access to public transport
		Satisfaction with quality of public transport
	(Inter-)national accessibility	International accessibility
	Availability of ICT-infrastructure	Computers in households
		Broadband Internet access in households
	Sustainable, innovative and safe transport	Green mobility share (non-motorized individual traffic)
		Traffic safety
Use of economical cars		

Characteristics	Factors	Indicators
Smart environment	Attractivity of natural conditions	Sunshine hours
		Green space share
	Pollution	Summer smog (ozone)
		Particulate matter
		Fatal chronic lower respiratory diseases per inhabitant
	Environmental protection	Individual efforts on protecting nature
		Opinion on nature protection
	Sustainable resource management	Efficient use of water (use per GDP)
		Efficient use of electricity (use per GDP)
	Smart people	Level of qualification
Population qualified at level 5-6 of ISCED		
Foreign language skills		
Affinity to lifelong learning		Book loans per resident
		Participation in lifelong learning in %
		Participation in language courses
Social and ethnic plurality		Share of foreigners
		Share of nationals born abroad
Flexibility		Percentage of getting a new job
Creativity		Share of people working in creative industries
Cosmopolitanism/open-mindedness		Votes turnout at European elections
		Immigration-friendly environment (attitude towards immigration)
		Knowledge about EU
Participation in public life		Voters turnout at city elections
		Participation in voluntary work
Smart living	Cultural facilities	Cinema attendance per inhabitant
		Museums visits per inhabitant
		Theatre attendance per inhabitant
	Health conditions	Life expectancy
		Hospital beds per inhabitant
		Doctors per inhabitant
		Satisfaction with quality of health system
	Individual safety	Crime rate
		Death rate by assault
		Satisfaction with personal safety

Characteristics	Factors	Indicators
	<b>Housing quality</b>	Share of housing fulfilling minimal standards
		Average living area per inhabitant
		Satisfaction with personal housing situation
	<b>Education facilities</b>	Student per inhabitant
		Satisfaction with access to educational system
		Satisfaction with quality of educational system
	<b>Touristic attractivity</b>	Importance as tourist location (overnights, sights)
		Overnights per year per resident
	<b>Social cohesion</b>	Perception on personal risk of poverty
		Poverty rate
<b>Smart governance</b>	<b>Participation in decision-making</b>	City representatives per resident
		Political activity of inhabitants
		Importance of politics for inhabitants
		Share of female city representatives
	<b>Public and social services</b>	Expenditure of the municipal per resident in prospective payment system (PPS)
		Share of children in day care
		Satisfaction with quality of schools
	<b>Transparent governance</b>	Satisfaction with transparency of bureaucracy
		Satisfaction with fight against corruption
	<i>Political strategies and perspectives</i>	0

## Annex M

### Leibnitz Institute: European system of social indicators

Source: Berger-Schmitt R. and Noll H.-H. (2000), "Conceptual framework and structure of a European system of social indicators". Towards a European system of social reporting and welfare measurement, A TSER-project financed by the European Commission, Centre for Survey Research and Methodology (ZUMA), Social Indicators Department, Mannheim, 2000.

[http://www.gesis.org/fileadmin/upload/dienstleistung/daten/soz\\_indikatoren/eusi/paper9.pdf](http://www.gesis.org/fileadmin/upload/dienstleistung/daten/soz_indikatoren/eusi/paper9.pdf)

A European cooperation called the *European System of Social Indicators* (EUSI), originally a project sponsored by EC, has focused on listing relevant indicators, instead of constructing an index. Life quality, social unity and sustainability are being measured by objective and subjective indicators. The *European System of Social Indicators* (EUSI) documentation defines three goals and each goal lists a set of indicators.

**Table M.1 – goals of European System of Social Indicators (EUSI)**

<b>Goal 1: Economic and social progress, improvement of quality of life</b>
<ul style="list-style-type: none"> <li>▪ Promotion of employment – combat unemployment</li> <li>▪ Enhancement of education</li> <li>▪ Use of ICT</li> <li>▪ Improving of public health</li> <li>▪ Social security of people</li> <li>▪ Improvement of personal safety</li> <li>▪ Reduction of environmental pollution and the improvement of environmental protection</li> </ul>
<b>Goal 2: Strengthening the economic and social cohesion</b>
<ul style="list-style-type: none"> <li>▪ Reduction of regional disparities</li> <li>▪ Equal opportunities for men and women</li> <li>▪ Equal opportunities for disabled people</li> <li>▪ Combat social exclusion and discrimination</li> <li>▪ Encouraging solidarity between people</li> <li>▪ Enhancement of physical connections (transport)</li> <li>▪ Developing Trans-European Networks (TENs) in areas of energy, transport and telecommunications</li> </ul>
<b>Goal 3: Sustainable development</b>

The third goal is related to the commitment of sustainable development. The challenge of a sustainable Europe is to achieve economic growth based on higher employment rates, less environmental pollution and improved resource efficiency of energy and raw materials. Below is a list of the measuring points for each domain and goal.

**Table M.2 – measuring points for life domain of European System of Social Indicators (EUSI)**

Life domain: population	
Goal dimensions	Measurement dimensions
<b>Social structure</b>	
Demographic structure	Population size and growth
	Population structure (age, marital status)
	Population density and agglomeration
	Migration / foreigners
Life domain: households and families	
Goal dimensions	Measurement dimensions
Reduction of disparities/inequalities	Equal opportunities/inequalities of :
	1: Women and men regarding
	A: Engagement in house work and child care,
	B: Attitudes towards gender roles
	2: Generations regarding
A: Availability of family relations	
Strengthening social connections and ties – social capital	Existence and intensity of family relations
	Care for old ages household members
	Quality of relations between household members
Preservation of human capital	Household performances in educating and caring for children
Social structure – demographic structure	Structure of private households and families
	Marriages and divorces
Social structure – values and attitudes	Attitudes towards marriage
	Attitudes towards family and children
Life domain: housing	
Goal dimensions	Measurement dimensions
Improvement of objective living conditions	Age of housing stock
	Level of supply with dwellings and housing space
	Size of dwellings
	Equipment of dwellings
	Security
	Housing costs
	Quality of environs

Enhancement of Subjective well-being	Subjective perception and evaluation of:
	1. Housing conditions
	2. Quality of environs
Reduction of disparities/inequalities	Regional disparities of housing conditions
	Equal opportunities/inequalities regarding housing of:
	1. Disabled people
	2. Social strata
	Social exclusions: (homelessness, poor housing conditions)
Preservation of natural capital	Area used for settlement
<b>Life domain: transport</b>	
<b>Goal dimensions</b>	<b>Measurement dimensions</b>
Improvement of objective living conditions	Access to transport
	Travel speed
	Costs of transports
Enhancement of subjective well-being (SWB)	Subjective perception an evaluation of:
	1. Transport conditions
	2. Noise pollution
Reduction of disparities/inequalities	Regional disparities of access to and quality of transport
	Equal opportunities/inequalities regarding transport of disabled people
	Social exclusion: no access to private and public transport
Strengthening social connections and ties – social capital	European-specific concerns:
	1. Quality of transport connections between European countries
	2. Frequency of journeys in European countries
Preservation of human capital	Traffic accidents
Preservation of natural capital	Pollution due to transport
	Consumption of natural resources due to transport (energy, area)
<b>Life domain: Leisure, media and culture</b>	
<b>Goal dimensions</b>	<b>Measurement dimensions</b>
Improvement of objective living conditions	Amount of leisure time
	Availability of facilities and goods in the area of leisure, media and culture



Enhancement of SWB	Subjective perception an evaluation of:
	<ol style="list-style-type: none"> <li>1. Leisure time</li> <li>2. Possibilities for recreational and cultural activities</li> </ol>
Reduction of disparities/inequalities	Regional disparities in the availability of facilities and goods in the area of leisure, media and culture
	Equal opportunities/inequalities of
	<ol style="list-style-type: none"> <li>1. Women and men regarding leisure time</li> <li>2. Disabled people regarding access to media recreational and cultural facilities</li> </ol>
Strengthening social connections and ties – social capital	European-specific concerns: Exchange of cultural products between European countries
Preservation of human capital	Leisure activities promoting health
	Leisure activities promoting human knowledge
Preservation of natural capital	Consumption of paper
Social structure: values and attitudes	Subjective importance of leisure and culture
<b>Life domain: Social and political participation and integration</b>	
<b>Goal dimensions</b>	<b>Measurement dimensions</b>
Reduction of disparities/inequalities	Equal opportunities/inequalities regarding social and political participation and integration of:
	1. Women and men
	2. Generations
	3. Social strata
	4. Disabled people
	5. Citizenship groups
	Social exclusion: social isolation
Strengthening social connections and ties – social capital	Availability of social relations (personal relations outside family, informal networks, membership in associations)
	Social and political activities and engagement (frequency of contacts, support in information networks, volunteering, political engagement)
	Quality of social relations (extent of trust, feelings of belonging, shared values, solidarity, conflicts, attitudes towards population groups, loneliness)
	Trust in institutions: political institutions
	European-specific concerns:
	1. European identity
	2. Social relation and attitudes to national from European countries
	3. Commonalities between European countries in basic values and attitudes
4. Social and political activities at the European level	

Social structure: values and attitudes	Political orientation
	Subjective importance of religion
<b>Life domain: Education and vocational training</b>	
<b>Goal dimensions</b>	<b>Measurement dimensions</b>
Improvement of objective living conditions	Level of education and vocational training
	Effectiveness of education
Enhancement of SWB	Subjective perception and evaluation of level of education and vocational training
Reduction of disparities/inequalities	Regional disparities of
	1: Access to education and vocational training
	2: Investment in education
	Equal opportunities /inequalities regarding educational participation and qualification of:
	1. Men and women
	2. Social strata
	3. Disabled people
	4. Citizenship groups
Social exclusion: lack of completed education and vocational training	
Strengthening social connections and ties – social capital	Trust in institutions: educational institutions
	European-specific conditions:
	1. Exchange of pupils, students, apprentices
	2. Teaching and dissemination of European languages
Preservation of human capital	Access to educational institutions
	Enrolment of young people in general education and vocational training
	Participation in continuing training
	Teachers, university personnel
	GDP spent on education
Social structure: values and attitudes	Subjective importance of education
<b>Life domain: Labour market and working conditions</b>	
<b>Goal dimensions</b>	<b>Measurement dimensions</b>
Improvement of objective living conditions	Labour market: opportunities and risks
	Employment level
	Working conditions
	Mobility
	Unemployment

Enhancement of SWB	Subjective perception and evaluation of personal employment situation
Reduction of disparities/inequalities	Regional disparities of employment opportunities and risks
	Equal opportunities/inequalities regarding employment of
	1. Men and women
	2. Social strata
	3. Disabled people
	4. Citizenship groups
Strengthening social connections and ties – social capital	Social exclusion: long-term unemployment
	Participation in the area of working life
	Quality of social relations at the work place
	Trust in institutions: trade unions
	European-specific concerns: exchange of working people between countries
Preservation of human capital	Working accidents and occupational diseases
	Participation in continuing training
Preservation of natural capital	Consumption of natural resources by economy
	Environmental pollution by economy
Social structure: Socio-economic structure	Employment status
	Occupational structure
	Sector structure
Social structure: Values and attitudes	Subjective importance of work and job characteristics
<b>Life domain: Income, standard of living, and consumption patterns</b>	
<b>Goal dimensions</b>	<b>Measurement dimensions</b>
Improvement of objective living conditions	Income level and growth
	Assets
	Level of supply with private goods and services
	Discretionary of income expenditure
Enhancement of SWB	Subjective perception and evaluation of financial situation and level of living
Reduction of disparities/inequalities	Inequity of income and standard of living
	Subjective evaluations of inequality of income and standard of living
	Regional disparities of income and standard of living
	Equal opportunities/inequalities regarding income and standard of living of
	1. Men and women
	2. Generations

	3. Social strata
	4. Disabled people
	Social exclusion: poverty
Preservation of human capital	Healthy consumption patterns
Preservation of natural capital	Consumption of natural resources by private households (for example energy, water, materials)
	Environmental pollution by private households (for example non-recyclable waste, ozone depleting substances)
	Non-polluting consumption patterns (for example ecologically produced food, products made of recycled material)
	Attitudes towards consumption habits
Social structure: Values and attitudes	Subjective importance of income and wealth
<b>Life domain: Health</b>	
<b>Goal dimensions</b>	<b>Measurement dimensions</b>
Improvement of objective living conditions	State of health
Enhancement of SWB	Subjective perception and evaluation of the state of health
Reduction of disparities/inequalities	Regional disparities of availability of health care facilities
	Equal opportunities/inequalities between social strata in the area of health
	Social exclusion: heavy health impairments
Strengthening social connections and ties – social capital	Trust in institutions: system of health care
Preservation of human capital	Availability of health care facilities
	Health expenditures
	Health prevention measures
	Measures of rehabilitation
<b>Life domain: Environment</b>	
<b>Goal dimensions</b>	<b>Measurement dimensions</b>
Improvement of objective living conditions	Stock of natural resources (minerals, oil, water, flora and fauna)
	State of the environment (quality of air, water, forests, soil)
Enhancement of SWB	Subjective perception and evaluation of the environment
Reduction of disparities/inequalities	Regional disparities in the state of environment
Preservation of human capital	Health hazards (e.g. By pollution, accidents, noxious substances in food)

Preservation of natural capital	Eco-efficiency: resource use per unit of product or service or per unit of GDP (energy efficiency, material efficiency)
	Share of renewable energy sources
	Pollution per unit of energy consumption
	Public expenditures on environmental protection and research
	Share of protected areas
Social structure: Values and attitudes	Subjective importance of the environment
<b>Life domain: Social security</b>	
<b>Goal dimensions</b>	<b>Measurement dimensions</b>
Improvement of objective living conditions	Coverage of social security
	Efficiency of social insurance
Enhancement of SWB	Equal opportunities/inequalities regarding social security of
	1. Men and women
	2. Generations
Strengthening social connections and ties – social capital	Trust in institutions: social security institutions
<b>Life domain: Public safety and crime</b>	
<b>Goal dimensions</b>	<b>Measurement dimensions</b>
Improvement of objective living conditions	Extent of criminality
	Structure of offenders
	Structure of victims
	Protection and combat against crime
Enhancement of SWB	Subjective perception and evaluation of public safety
Reduction of disparities/inequalities	Regional disparities of the extent of criminality
	Inequalities regarding public safety of
	1. Men and women
	2. Generations
	3. Citizens groups
4. Races	
Strengthening social connections and ties – social capital	Trust in institutions: legal system

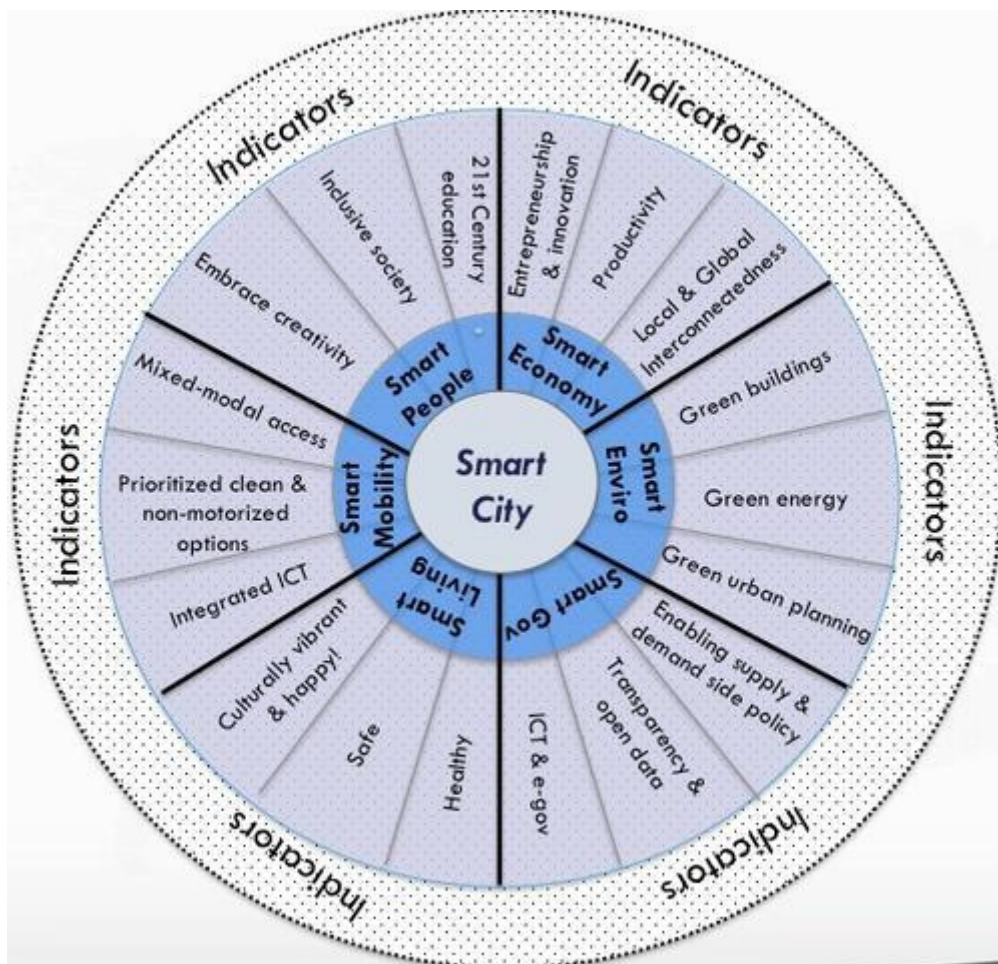
Total life situation	
Goal dimensions	Measurement dimensions
Improvement of objective living conditions	Comprehensive welfare indices
Enhancement of SWB	Subjective perception and evaluation of the total living situation
Reduction of disparities/inequalities	Regional disparities in comprising welfare measures
	Inequalities regarding comprehensive measures of quality of life of:
	1. Men and women
	2. Generations
	3. Social strata
	4. Disabled people
	5. Citizenship groups
	Equal opportunities of generations regarding quality of life: public debts per capita
Social exclusion: multiple deprivation	
Social structure: Socio-economic structure	Social stratification
Social structure: Values and attitudes	Materialism – post-materialism
	Equality
	Freedom
	Security



## Annex N

### Smart Cities Wheel

Source: [Boyd Cohen, http://www.boydcohen.com/smartcities.html](http://www.boydcohen.com/smartcities.html)



There are six key components, and three key drivers for each component [7].

**Table N.1 – key components and drivers of smart city wheel**

Key component	Key driver
Smart economy	Entrepreneurship and innovation
	Productivity
	Local and global interconnectedness
Smart environment	Green buildings
	Green energy
	Green urban planning
Smart governance	Enabling supply and demand side policy
	Transparency and open data
	ICT and e-government

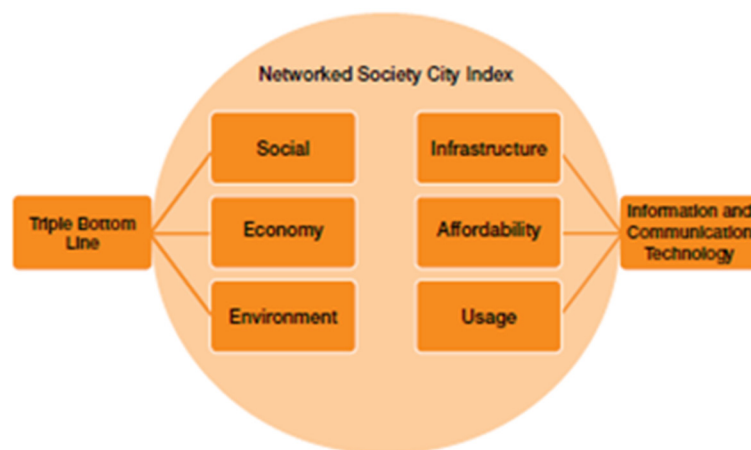
Key component	Key driver
Smart living	Culturally vibrant and happy
	Safe
	Healthy
Smart mobility	Mixed-model access
	Prioritized clean and non-motorized options
	Integrated ICT
Smart people	21st century education
	Inclusive society
	Embrace creativity

## Annex O

### Ericsson: Networked society city index

Source:

Ericsson, <http://www.ericsson.com/res/docs/2013/ns-city-index-report-2013.pdf>  
<http://www.ericsson.com/res/docs/2013/ns-city-index-report-2013-methodology.pdf>



**Triple Bottom Line: 8 Variables and 21 proxies.**

- > **Social**
  - > Health
  - > Education
  - > Social Inclusion
- > **Economy**
  - > Productivity
  - > Competitiveness
- > **Environment**
  - > Resources
  - > Pollution
  - > Climate change

**ICT Maturity: 7 Variables and 18 proxies.**

- > **Infrastructure**
  - > Broadband quality
  - > Availability
- > **Affordability**
  - > Tariffs
  - > IP Transit prices
- > **Usage**
  - > Technology use
  - > Individual use
  - > Public and market use

**Table O.1 – networked society city index**

Dimension	Variable	Indicator	Proxy
Social	Health	Infant mortality	Death of children under the age of one
		Life expectancy	Average life expectancy
	Education	Education attainment	Upper secondary or tertiary education attainment
		Literacy rate	Percentage of literate people

Dimension	Variable	Indicator	Proxy
	<b>Social inclusion</b>	Homicide rate	Murders per 100000 inhabitants
		Unemployment rate	Unemployment as a percentage of the labour force
<b>Economy</b>	<b>Productivity</b>	Gross domestic product (GDP) per capita	GDP in dollars purchasing power parity (PPP) per capita
	<b>Competitiveness</b>	Tertiary education attainment	Percent to have attained tertiary education
		Patents	Patent cooperation treaty (PCT) patents per million inhabitants
		Knowledge-intensive employment	Percent of Knowledge-intensive services (KIS)
		Business start-up	New enterprises per 100,000 inhabitants
<b>Environment</b>	<b>Resources</b>	Waste	Recycled waste per person Non-recycled waste per person
		Energy	Fossil fuels consumption per capita Non-fossil fuels consumption per capita
		(Material)	(Not included so far)
	<b>Pollution</b>	Air	PM10 microgram/m <sup>3</sup> PM2.5 microgram/m <sup>3</sup> NO <sub>2</sub> microgram/m <sup>3</sup> SO <sub>2</sub> microgram/m <sup>3</sup>
		Water	Percentage of the wastewater treated
		(Land)	(Not included so far)
		<b>Climate change</b>	CO <sub>2</sub>

Dimension	Variable	Indicator	Proxy
ICT infrastructure	Broadband quality	Fixed broadband (BB) quality	Mean download speed
		Mobile BB quality	Cell edge performance
		Bandwidth capacity	International bandwidth capacity
	Availability	Internet access	Percentage with Internet access at home
		Fiber	FTTH/FTTB penetration
		LTE/HSPA+	Three largest operators have HSPA+ or LTE
		WiFi hotspots	Number of WiFi hotspots
ICT affordability	Tariffs	Fixed BB tariffs	BB tariffs as percentage of GDP per capita
		Mobile cellular tariffs	Mobile tariffs as percentage of GDP per capita
	IP transit prices	IP transit prices	Median IP transit prices per Mbps, 10Gb Ethernet
ICT usage	Technology use	Mobile phones	Mobile phone subscriptions
		Smartphones	Number of smartphones per capita
		Computers	Percentage with a computer at home
		Tablets	Number of tablets per capita
	Individual use	Internet use	Internet usage as a percentage of the population
		Social networking	Social networking penetration
	Public and market use	Open data	Open data homepage and application programming interface (API)
		Electronic payments	Electronic and mobile phone payments

## Annex P

### IBM: Smarter city assessment

Source: Dencik, J. (2010). Smarter city assessment. Presentation by IBM in Leuven, 1 June 2010.

**Table P.1 – smarter city assessment**

<b>People</b>
Investment in education
Investment in health
Expenditure on public safety
Investment in housing
Strategic planning and performance management for skills
Strategic planning and performance management for health
Strategic planning and performance management for public safety
Strategic planning and performance management for housing
ICT for education
ICT for health
Smart technologies for public safety
Smart technologies for housing
Education outcomes
Health outcomes
Public safety outcomes
Housing outcomes
Quality of life
<b>Business</b>
Access to finance
Business real estate
Openness to trade/access to markets
Strategic planning and performance management for business
Administrative burden
Efficient regulation
E-business
Business dynamics and entrepreneurship
<b>Communication</b>
Investment in telecommunication infrastructure
Presence of communication services
Strategic planning and performance management for communication systems
Deployment of broadband
Wi-Fi coverage
Quality and reliability of communication infrastructure
Access to communication services/digital divide
ICT take-up and use



Transport
Investment in transport infrastructure
Presence and quality of transport infrastructure
Public transport
Strategic planning and performance management
Congestion management
Energy efficiency of transport system
Accessibility
Congestion management
Pollution and climate change
Road safety
Energy
Quality of basic energy infrastructure
Investment in energy infrastructure
Strategic planning and performance management for energy system
Smart grid
Smart metre use
Reliability of energy supply
Energy losses
Renewable energy
CO <sub>2</sub> emissions from household energy
Water
Investment in water infrastructure
Investment in flood defences
Strategic planning and performance management
Use of smart metering and pricing
Access to water and sewage
Water quality
Water usage
Water waste
Prevalence and cost of flooding
City services
Local government expenditure/budget
Local government staff
Strategic planning and performance measurement
Integrated information system
E-government
Efficiency and effectiveness of service delivery

## Annex Q

### IDC: Index system of SSC

Source: <http://www.slideshare.net/cibbva/idcwp38-t-print>

#### D1 Key components of smartness

There are five smartness dimensions: smart government, smart buildings, smart mobility, smart energy and environment, and smart services.

There are three enabling forces: people, economy, and ICT [6].

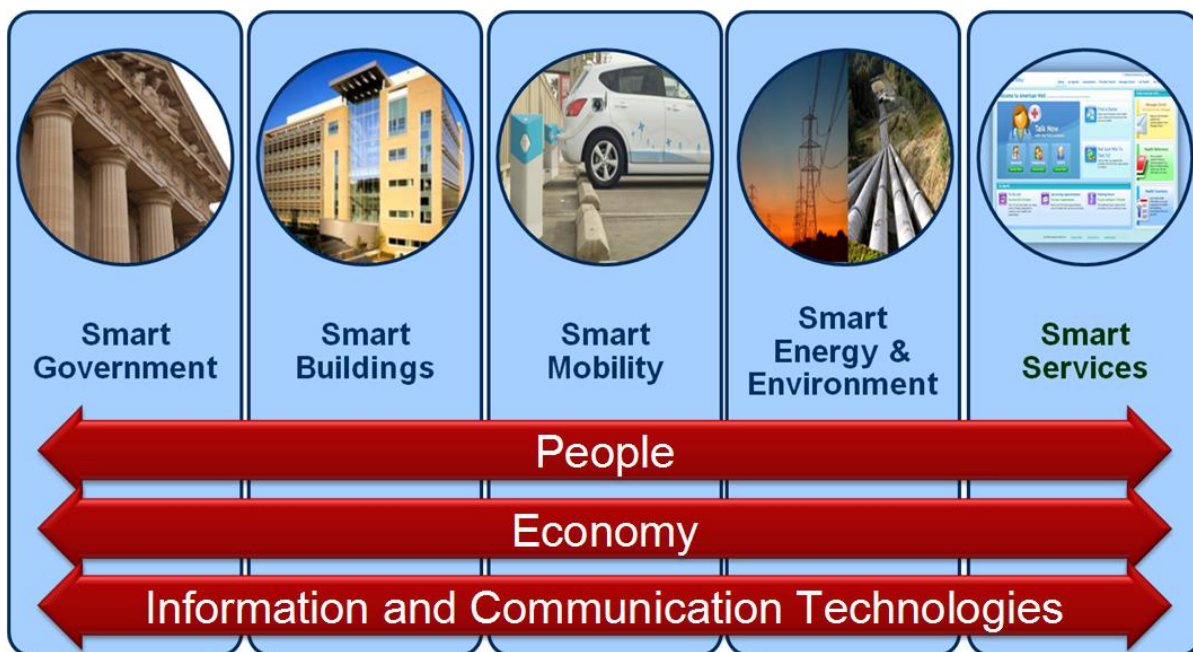


Figure Q.1 framework of IDC index system of SSC

#### D2 Component weighting

##### Enabling forces

Table Q.1 – component weighting of criteria - Enabling forces

Criteria	weighting
People	30
Economy	30
ICT	40
<b>Total</b>	<b>100</b>

## Smartness dimensions

**Table Q.2 – component weighting of criteria - Smartness dimensions**

Criteria	weighting
Smart government	20
Smart buildings	20
Smart mobility	20
Smart energy and environment	20
Smart services	20
<b>Total</b>	<b>100</b>

## Enabling forces

**Table Q.3 – component weighting of sub-criteria - Enabling forces**

Criteria	Sub-criteria	weighting
People	Age	40
	Education	30
	Population dynamics	30
	<b>Subtotal</b>	<b>100</b>
Economy	Economic wealth	40
	Economic make-up	30
	Economic dynamics	30
	<b>Subtotal</b>	<b>100</b>
ICT	Adoption	40
	Mobile	60
	<b>Subtotal</b>	<b>100</b>

## Smartness dimensions

**Table Q.4 – component weighting of sub-criteria - Smartness dimensions**

Criteria	Sub-criteria	weighting
Smart government	Communication	10
	Sustainable behavior	30
	Environment protection policy	20
	e-Services	40
	<b>Subtotal</b>	<b>100</b>
Smart buildings	Efficiency in operations	60
	Quality of construction	40
	<b>Subtotal</b>	<b>100</b>

Criteria	Sub-criteria	weighting
Smart mobility	Electromobility ( including low carbon)	40
	Traffic intelligence	40
	Teleworking	20
	Subtotal	100
Smart energy and environment	Intelligence of distribution networks	30
	Clean energy	40
	Sustainable environment	30
	Subtotal	100
Smart services	Security	40
	Emergency	30
	Services for the community	30
	Subtotal	100

### D3 Key indicators

#### Enabling forces

Table Q.5 – Key indicators - Enabling forces

Criteria	Sub-criteria	Indicator #	Indicator
People	Age	A.1	Average citizen age
	Education	A.2	Level of literacy
		A.3	Average level of education
	Population dynamics	A.4	Population growth CAGR 2005-2010
Economy	Economic wealth	B.1	GDP per capita
		B.2	Energy/electricity consumption per capita
		B.3	Percentage of register unemployment, total unemployment (2009)
	Economic make-up	B.4	Economic activity index, industrial index, commercial index, etc.
	Economic dynamics	B.5	GDP growth rate
B.6		Variation of registered unemployment CAGR 5 years	
ICT	Adoption	C.1	ICT spending per capita
		C.2	Personal computer (PC) per capita
		C.3	Broadband lines per capita
	Mobile	C.4	Number of SIM cards per capita
		C.5	Internet access (percentage of population)

**Smartness dimensions**
**Table Q.6 – Key indicators - Smartness dimensions**

Criteria	Sub-criteria	Indicator #	Indicator
1.Smart government	Communication	1.1	(Online) free public access to government spending
	Sustainable behaviour	1.2	Existence of congestion charge
		1.3	# of electric vehicles (EVs) in local government's vehicle fleet
		1.4	Public light automation and control systems (level of adoption)
		1.5	Emissions monitoring system (level of adoption)
		1.6	Internal administrative process integration and data sharing (level)
		1.7	Urbanization planning (level of adoption and level of digitalization)
	Environment protection policy	1.8	City is signatory of Covenant of Mayors European Initiative
		1.9	Quantified parameter goals for city's sustainability (emissions, RES, energy efficiency)
	e-Services	1.10	Percentage of vital certificates/records obtainable online (e-Government)
		1.11	Availability of e-Registry
		1.12	Availability of e-Taxes
		1.13	Availability of Digital Property Registry
2. Smart buildings	Efficiency in operations	2.1	Energy consumption per square meter
		2.2	Percentage of buildings served by district heating/cooling
		2.3	Percentage of buildings with an energy management systems
		2.4	Percentage of building automation systems (%)
		2.5	Penetration of lighting control system (%)
	Quality of construction	2.6	Minimum level of energy class standards for construction of new buildings
		2.7	Percentage of buildings of class "A" energy efficiency standard
3. Smart mobility	Electromobility ( including low carbon)	3.1	# of public electrical vehicle charging points
		3.2	Percentage of public transport that is "green" (runs on low emission fuels)

Criteria	Sub-criteria	Indicator #	Indicator
	Traffic intelligence	3.3	City incentive program for low emission vehicles
		3.4	Car-pooling initiatives
		3.5	Percentage of traffic lights that are intelligent
		3.6	Web-portals for traffic information
		3.7	Real-time passenger information display systems
		3.8	Systems for traffic monitoring and congestion prediction
	Teleworking	3.9	Percentage of remote workers
4. Smart energy and environment	Intelligence of distribution networks	4.1	Percentage of smart meters installed to date /2011/2010
		4.2	Percentage of network automation (electricity, gas and water)
	Clean energy	4.3	Weight of renewable energy sources (RES) on total consumption
		4.4	Percentage of energy consumption from district heating/cooling
	Sustainable environment	4.5	CO <sub>2</sub> emissions per capita
		4.6	NOX and other emissions
		4.7	Electricity consumption (on GDP)
		4.8	Waste generated (per capita)
		4.9	Water consumption (per capita)
		4.10	Average number of citizens per water purifier
		4.11	Waste to energy power plant (level of adoption)
		4.12	Percentage of differentiated/categorized recycling
5. Smart services	Security	5.1	City video surveillance penetration
		5.2	Police mobile devices and applications (level of adoption)
	Emergency	5.3	Sensors and control system for fire prevention (availability)
		5.4	Flood control/predictive systems
	Services for the community	5.5	Surface of green area (on total city surface)
		5.6	Digital access to urban planning documents
		5.7	E-tourism penetration
		5.8	Availability of education



## Annex R

### PwC: Cities of opportunities index

Source: PwC and Partnership for New York City (2011). Cities of opportunities.

PwC and Partnership for New York City (2012). Cities of opportunities,  
<http://www.pwc.com/us/en/cities-of-opportunity/2012/pdf-download.jhtml>

The indicators below were used for 2011.

**Table R.1 – PwC: Cities of opportunities index**

<b><i>Air pollution</i></b>	Measurement of the quality of a city's air based on the degree of pollution from sources such as vehicles and power plants.
<b><i>Aircraft movements</i></b>	Count of air traffic movements at each of the major airports servicing a city, including civil international and domestic passenger, cargo and non-revenue flights but excluding military flights.
<b><i>Airport to CBD access</i></b>	Measure of the ease of using public transit to travel between a city's central business district and the international terminal of its busiest airport in terms of international passenger traffic. Cities are separated into categories according to whether a direct rail link exists between the city center and the airport – if so, the number of transfers required, and if not, whether there is a public express bus route to the airport. Cities with direct rail links are preferred to those with express bus services. Cities with rail links with fewer transfers are ranked higher than those with more. Cities are ranked against other cities in the same category according to the cost of a single one-way, adult weekday trip and the length of the trip, with each factor weighted equally.
<b><i>Attracting FDI: capital investment</i></b>	Total value of greenfield (new job-creating) capital investment activities in USD in a city that are funded by foreign direct investment. Data cover the period from January 2003 through May 2010.
<b><i>Attracting FDI: number of greenfield projects</i></b>	Number of greenfield (new job-creating) projects in a city that are funded by foreign direct investment. Data cover the period from January 2003 through May 2010.
<b><i>Broadband quality score</i></b>	Measurement of the quality of a broadband connection in a given country. The Broadband Quality Study is an index that is calculated based on the normalized values of three key performance parameter categories: download throughput, upload throughput and latency. A formula weights each category according to the quality requirements of a set of popular current and probable future broadband applications.
<b><i>Business trip index</i></b>	Weighted index of the cost of a business trip to a city, including measures such as taxi cab rates, lunch prices, and quality of entertainment and infrastructure. The business travel index comprises the following five categories: stability, health care, culture and environment, infrastructure and cost.

<b>City carbon footprint</b>	Annual amount of CO <sub>2</sub> emissions in metric tons divided by the city population. Supplemental national reports on data and policies on greenhouse gas emissions were used when city-level data were not available.
<b>Classroom size</b>	Number of students enrolled in public primary education programs divided by the number of classes in these programs. Primary education programs usually begin at ages five to seven and last four to six years. Primary education is counted as the equivalent of kindergarten through grade 5 in the US education system wherever possible.
<b>Commute time</b>	Assessment of the average commute time for workers commuting into or within a city across all modes of transport, measured in minutes.
<b>Cost of business occupancy</b>	Annual gross rent divided by square feet of Class A office space. Gross rent includes lease rates, property taxes, and maintenance and management costs.
<b>Cost of living</b>	Measure of the comparative cost of more than 200 items in each city. Counted items include housing, transport, food, clothing, household goods and entertainment.
<b>Cost of public transport</b>	Cost of the longest mass transit rail trip within a city's boundaries. The cost of a bus trip is used in the cities where there are no rail systems.
<b>Crime</b>	Amount of reported crimes in a city such as petty and property crimes, violent crimes and street crimes.
<b>Cultural vibrancy</b>	Weighted combination of city rankings based on: the quality and variety of restaurants, theatrical and musical performances, and cinemas within each city; which cities recently have defined the "zeitgeist," or the spirit of the times; and the number of museums with online presence within each city. The "zeitgeist" rankings take into account cultural, social and economic considerations.
<b>Digital economy score</b>	Assessment of the quality of a country's information and communication technology (ICT) infrastructure and the ability of its consumers, businesses and governments to use ICT to their benefit.
<b>Domestic market capitalization</b>	Total number of issued shares of domestic companies listed at a city's stock exchange(s) multiplied by their respective prices at a given time. This figure reflects the comprehensive value of the market at that time in millions of USD.
<b>Ease of entry: number of countries with visa waiver</b>	Number of nationalities able to enter the country for a tourist or business visit without a visa. Excludes those nationalities for whom only those with biometric, diplomatic or official passports may enter without a visa.
<b>Ease of firing</b>	Ranking based on notification and approval requirements for termination of a redundant worker or a group of redundant workers, obligation to reassign or retrain, and priority rules for redundancy and re-employment.
<b>Ease of hiring</b>	Ranking based on restrictions and regulations that employers must follow when taking on new staff.
<b>Ease of starting a business</b>	Assessment of the bureaucratic and legal hurdles an entrepreneur must overcome to incorporate and register a new firm. Accounts for the number of procedures required to register a firm; the amount of time in days required to register a firm; the cost (as a percentage of per capita income) of official fees and fees for legally mandated legal or professional services; and the minimum amount of capital (as a percentage of per capita income) that an entrepreneur must deposit in a bank or with a notary before registration and up to three months following incorporation.

<b><i>End-of-life care</i></b>	Ranking of countries according to their provision of end-of-life care. The Quality of Death Index scores countries across four categories: Basic End-of-Life Healthcare Environment; Availability of End-of-Life Care; Cost of End of-Life Care; and Quality of End-of-Life Care. These indicator categories are composed of 27 variables, including quantitative, qualitative and "status" (whether or not something is the case) data. The indicator data are aggregated, normalized, and weighted to create the total index score.
<b><i>Entrepreneurial environment</i></b>	Measurement of the entrepreneurial attitudes, entrepreneurial activity and entrepreneurial aspirations in a country. The Global Entrepreneurship Index integrates 31 variables, including quantitative and qualitative measures and individual-level data.
<b><i>Financial and business services employment</i></b>	Proportion of employees working in businesses located within a city in the financial and business services sectors to the total employed workforce in the city. Where industry data were disaggregated, the equivalents of "finance and insurance" and "real estate and rental and leasing" were included in financial services; and the equivalents of "professional and technical services" and "management of companies and enterprises" were included in business services.
<b><i>Flexibility of visa travel</i></b>	Ranking based on the number of visa waivers available for tourist or business visits and the length of time for which the visa waiver is granted. Ranking is based on the number of those countries that can stay for at least 90 days, excluding those countries whose residents can enter only without a visa if they have a biometric, diplomatic or official passport.
<b><i>Foreign embassies or consulates</i></b>	Number of countries that are represented by a consulate or embassy in each city.
<b><i>Green space as a percent of city area</i></b>	Proportion of a city's land area designated as recreational and green spaces to the total land area. Excludes undeveloped rugged terrain or wilderness that is either not easily accessible or not conducive to use as public open space.
<b><i>Health system performance</i></b>	Measurement of a country's health system performance made by comparing healthy life expectancy with health care expenditures per capita in that country, adjusted for average years of education (years of education is strongly associated with the health of populations in both developed and developing countries). Methodology adapted from the 2001 report "Comparative efficiency of national health systems: cross-national econometric analysis".
<b><i>Hospitals</i></b>	Ratio of all hospitals within each city accessible to international visitors to every 100,000 members of the total population.
<b><i>Hotel rooms</i></b>	Count of all hotel rooms within each city.
<b><i>Housing</i></b>	Measure of availability, diversity, cost and quality of housing, household appliances and furniture, as well as household maintenance and repair.
<b><i>Incoming/outgoing passenger flows</i></b>	Total number of incoming and outgoing passengers, including originating, terminating, transfer and transit passengers in each of the major airports servicing a city. Transfer and transit passengers are counted twice. Transit passengers are defined as air travellers coming from different ports of departure who stay at the airport for brief periods, usually one hour, with the intention of proceeding to their first port of destination (includes sea, air and other transport hubs).

<b><i>Inflation</i></b>	Ranking according to how far a country deviates from a +2% inflation rate, with inflation that is closer to +2% being favoured over inflation or deflation that is further from this rate. A +2% inflation rate is used as the benchmark because it is widely regarded as a target or healthy inflation rate by large international banks. A country's inflation rate is based on a projection of how much its Consumer Price Index, which measures the rise in prices of goods and services, is expected to rise during the course of 2010.
<b><i>Intellectual property protection</i></b>	Leading business executives' responses to the question in the World Economic Forum's Executive Opinion Survey 2010 that asks, "How would you rate intellectual property protection, including anti-counterfeiting measures, in your country? (1 = very weak; 7 = very strong)." The survey covers a random sample of large and small companies in the agricultural, manufacturing, non-manufacturing, and service sectors.
<b><i>International tourists</i></b>	Annual international tourist arrivals for 100 cities collected by Euromonitor International. Euromonitor's figures include travellers who pass through a city, as well as actual visitors to the city.
<b><i>Internet access in schools</i></b>	Leading business executives' responses to the question in the World Economic Forum's Executive Opinion Survey 2010 that asks, "How would you rate the level of access to the Internet in schools in your country? (1 = very limited; 7 = extensive)." The survey covers a random sample of large and small companies in the agriculture, manufacturing, non-manufacturing, and service sectors.
<b><i>Level of shareholder protection</i></b>	Measurement of the strength of minority shareholder protection against misuse of corporate assets by directors for their personal gain. The Strength of the Investor Protection Index is the average of indices that measure "transparency of transactions," "liability for self-dealing" and "shareholders' ability to sue officers and directors for misconduct."
<b><i>Libraries with public access</i></b>	Number of libraries within each city that are open to the public divided by the total population and then multiplied by 100,000.
<b><i>Licensed taxis</i></b>	Number of officially licensed taxis in each city divided by the total population and then multiplied by 1,000.
<b><i>Life satisfaction</i></b>	Average score in robust international surveys of country populations in response to the question, "All things considered, how satisfied are you with your life as a whole these days?" The (Un) Happy Planet Index 2.0 predominantly drew its data from the 2006 Gallup World Poll, with the 2000 and 2005 World Values Surveys being used to fill in values for countries excluded from the Gallup survey. Responses are scored on a numeric scale from 0 to 10, where 0 is dissatisfied and 10 is satisfied.
<b><i>Literacy and enrollment</i></b>	Measurement of a country's ability to generate, adopt and diffuse knowledge. The World Bank's Knowledge Index is derived by averaging a country's normalized performance scores on variables in three categories – education and human resources, the innovation system, and information and communications technology. The variables that compose education and human resources are adult literacy rate, secondary education enrollment and tertiary education enrollment.
<b><i>Mass transit coverage</i></b>	Ratio of kilometers of mass transit track to every 100 square kilometers of the developed and developable portions of a city's land area. A city's developable land area is derived by subtracting green space and governmentally protected natural areas from total land area.

<b><i>Math/science skills attainment</i></b>	Top performers' combined mean scores on the math and science components of an Organisation for Economic Co-operation and Development (OECD) assessment of 15 year olds' academic preparedness. Top performers are defined as those students who achieved in the top two proficiency levels (Level 5 and Level 6) on the math and science portions of the test. Comparable examinations are used wherever possible to place cities not included in the OECD assessment.
<b><i>Miles of mass transit track</i></b>	Total miles of metro, tram and light rail track within a city divided by the total population and then multiplied by 100,000. Includes monorail and commuter rail that run within a city if they operate as metros in the city.
<b><i>Natural disaster risk</i></b>	Risk of natural disasters occurring in or near a city. Counted hazards include hurricanes, droughts, earthquakes, floods, landslides and volcanic eruptions.
<b><i>Number of global 500 headquarters</i></b>	Number of global 500 headquarters located in each city.
<b><i>Operational risk climate</i></b>	Quantitative assessment of the risks to business profitability in each of the countries. Assessment accounts for present conditions and expectations for the coming two years. The operational risk model considers 10 separate risk criteria: security, political stability, government effectiveness, legal and regulatory environment, macroeconomic risks, foreign trade and payment issues, labour markets, financial risks, tax policy, and standard of local infrastructure. The model uses 66 variables, of which about one-third are quantitative.
<b><i>Percent of gross domestic expenditure on R&amp;D</i></b>	Total gross domestic expenditure on research and development in 2007 as a percentage of the gross domestic product.
<b><i>Percent of population with higher education</i></b>	Number of people who have completed at least a university-level education divided by the total population. A university-level education is set equivalent to a Bachelor's degree or higher from a US undergraduate institution.
<b><i>Political environment</i></b>	Measure of a nation's relationship with foreign countries, internal stability, law enforcement, limitations on personal freedom and media censorship.
<b><i>Purchasing power</i></b>	Measure of the comparative relationship between prices and earnings calculated by dividing net hourly income by the cost of a basket of 122 goods and services, including rent.
<b><i>Quality of living</i></b>	Score based on more than 30 factors across five categories: socio-political stability, health care, culture and natural environment, education and infrastructure. Each city receives a rating of either acceptable, tolerable, uncomfortable, undesirable or intolerable for each variable. For qualitative indicators, ratings are awarded based on the Economic Intelligence Unit analysts' and in city contributors' judgments. For quantitative indicators, ratings are calculated based on cities' relative performances on a number of external data points.
<b><i>Recycled waste</i></b>	Percentage of municipal solid waste diverted from the waste stream to be recycled.

<b><i>Renewable energy consumption</i></b>	Percentage of total energy consumption in a nation that comes from renewable sources. Renewable energy sources include geothermal, solar thermal, solar voltaics, hydro, wind, and combustible renewable sources and waste (composed of solid biomass, liquid biomass, biogas, industrial waste and municipal waste). Non-renewable sources include coal and peat, crude oil, petroleum products, gas and nuclear.
<b><i>Research performance of top universities</i></b>	Sum of the scaled scores of a city's universities that are included in the rankings of top performing research universities in the world. Scaled scores are based on the number of articles published, number of citations to published work and the quantity of highly cited papers. The scoring accounts for social sciences papers but not humanities papers. The rankings favor large universities, universities with medical schools, and universities that focus predominantly on the "hard sciences" rather than social sciences and humanities.
<b><i>Rigidity of hours</i></b>	Ranking is based on the flexibility in scheduling of non-standard work hours and annual paid leave for a business.
<b><i>Skyline impact</i></b>	Measure of the visual impact of completed high-rise buildings on their skylines, accounting for the height and the breadth of a skyline. Cities are given scores based on the number of buildings located within them that are above 90 meters tall, with taller buildings receiving more points than smaller ones.
<b><i>Skyscraper construction activity</i></b>	Count of skyscraper construction projects in each city under way as of September 26, 2010. A skyscraper is defined as any building 12 stories or greater in height.
<b><i>Software and multimedia development and design</i></b>	Combined score for each city in fDi magazine's Best Cities for Software Development and Best Cities for Multi-Media Design Centres indices. Both indices weight a city's performance 70% based on the quality of the location and 30% based on the cost of the location. The software design index is based on an assessment of 120 quality competitiveness indicators. These indicators include availability and track record in ICT, availability of specialized-skills professionals such as scientists and engineers, access to venture capital, R&D capabilities, software exports, quality of ICT infrastructure and specialization in software development. The multimedia design centre rankings are based on an assessment of 120 quality competitiveness indicators, including the size of the location's leisure and entertainment sector, its specialization and track record, information technology infrastructure, quality of life and skills availability.
<b><i>Sport and leisure activities</i></b>	The quality and variety of sport and leisure activities within each city.
<b><i>Strength of currency (SDRs per currency unit)</i></b>	Currency value of the special drawing rights (SDRs) per currency unit. The currency value is determined by summing the values of a basket of major currencies (USD, euro, Japanese yen and pound sterling) in USD based on market exchange rates and the amount that can be bought by a given currency unit.



<p><b><i>Thermal comfort</i></b></p>	<p>Measure of the average deviation from optimal room temperature (72 degrees Fahrenheit) in a city. January and July heat indices were calculated for each city using an online tool that integrates average temperature and average morning relative humidity during each month. A final thermal comfort score was derived by first taking the difference between a city's heat index for each month and optimal room temperature and then averaging the absolute values of these differences.</p>
<p><b><i>Total tax rate</i></b></p>	<p>Total amount of taxes and any mandatory contributions required by local, state and national law payable by a business as a percent of its profit. This does not include employer contributions to health care coverage.</p>
<p><b><i>Traffic congestion</i></b></p>	<p>Measure of traffic congestion and congestion policies for each city scored on the level of congestion as well as the modernity, reliability and efficiency of public transport.</p>
<p><b><i>Workforce management risk</i></b></p>	<p>Ranking based on staffing risk in each city associated with recruitment, employment, restructuring, retirement and retrenchment. Risk was assessed based on 25 factors grouped into five indicator areas: demographic risks associated with labor supply, the economy and the society; risks related to governmental policies that help or hinder the management of people; education risk factors associated with finding qualified professionals in a given city; talent development risk factors related to the quality and availability of recruiting and training resources; and risks associated with employment practices. A lower score indicates a lower degree of overall staffing risk.</p>
<p><b><i>Working age population</i></b></p>	<p>Proportion of a city's population aged 15-64 to the total population of the city.</p>

## Annex S

### Siemens: Green city index

Source: Siemens. <http://www.siemens.com/entry/cc/en/greencityindex.htm>

The green city index was developed by Siemens. Green city index reports are developed for Europe, Asia, South America, North America, and Africa. The green city index focuses on environmental performance and the categories and indicators vary between the different geographical indices.

Eight categories are used in the European version index: CO<sub>2</sub> emissions, energy, buildings, transport, water, waste and land use, air quality and environmental governance; 16/30 indicators are derived from quantitative data (how the city is performing) and 14/30 of the indicators are qualitative assessments of the cities ambition and aspirations.

Reference: European Green City index – assessing the environmental performance of Europe's major cities – A research project conducted by the Economist Intelligence Unit, sponsored by Siemens. Siemens report.

**Table S.1 – European green city index**

European green city index			
Category indicator		Type	Description
CO <sub>2</sub>	CO <sub>2</sub> emissions	Quantitative	Total CO <sub>2</sub> emissions in tons per head.
	CO <sub>2</sub> intensity	Quantitative	Total CO <sub>2</sub> emissions in grams per unit of real GDP (2000 base year).
	CO <sub>2</sub> reduction strategy	Qualitative	An assessment of the ambitiousness of CO <sub>2</sub> emissions reduction strategy.
Energy	Energy consumption	Quantitative	Total final energy consumption, in gigajoules per head.
	Energy intensity	Quantitative	Total final energy consumption, in mega joules per unit of real GDP (in euros, 2000 base year).
	Renewable energy consumption	Quantitative	The percentage of total energy derived from renewable sources, as a share of the city's total energy consumption, in tera joules.
	Clean and efficient energy policies	Qualitative	An assessment of the extensiveness of policies promoting the use of clean and efficient energy.
Buildings	Energy consumption of residential buildings	Quantitative	Total final energy consumption in the residential sector, per square meter of residential floor space.
	Energy-efficient buildings standards	Qualitative	An assessment of the extensiveness of cities' energy efficiency standards for buildings.
	Energy-efficient buildings initiatives	Qualitative	An assessment of the extensiveness of efforts to promote energy efficiency of buildings.
Transport	Use of non-car transport	Quantitative	The total percentage of the working population travelling to work on public transport, by bicycle and by foot.

European green city index			
Category indicator		Type	Description
	Size of non-car transport network	Quantitative	Length of cycling lanes and the public transport network, in km per square meter of city area.
	Green transport promotion	Qualitative	An assessment of the extensiveness of efforts to increase the use of cleaner transport.
	Congestion reduction policies	Qualitative	An assessment of the efforts to reduce vehicle traffic within the city.
Water	Water consumption	Quantitative	Total annual water consumption, in cubic meters per head.
	Water system leakage	Quantitative	Percentage of water lost in the water distribution system.
	Wastewater treatment	Quantitative	Percentage of dwellings connected to the sewage system.
	Water efficiency and treatment policies	Qualitative	An assessment of the comprehensiveness of measures to improve the efficiency of water usage and the treatment of wastewater.
Waste and land use	Municipal waste production	Quantitative	Total annual municipal waste collected, in kg per head.
	Waste recycling	Quantitative	Percentage of municipal waste recycled.
	Waste reduction and policies	Qualitative	An assessment of the extensiveness of measures to reduce the overall production of waste, and to recycle and reuse waste.
	Green land use policies	Qualitative	An assessment of the comprehensiveness of policies to contain the urban sprawl and promote the availability of green spaces.
Air quality	Nitrogen dioxide	Quantitative	Annual daily mean of NO <sub>2</sub> emissions.
	Ozone	Quantitative	Annual daily mean of O <sub>3</sub> emissions.
	Particulate matter	Quantitative	Annual daily mean of PM <sub>10</sub> emissions.
	Sulphur dioxide	Quantitative	Annual daily mean of SO <sub>2</sub> emissions.
	Clean air policies	Qualitative	An assessment of the extensiveness of policies to improve air quality.
Environmental governance	Green action plan	Qualitative	An assessment of the ambitiousness and comprehensiveness of strategies to improve and monitor environmental performance.
	Green management	Qualitative	An assessment of the management of environmental issues and commitment to achieving international environmental standards.
	Public participation in green policy	Qualitative	An assessment of the extent to which citizens may participate in environmental decision-making.

Siemens web sites include links to the Green city index reports.

<http://www.siemens.com/entry/cc/en/greencityindex.htm>

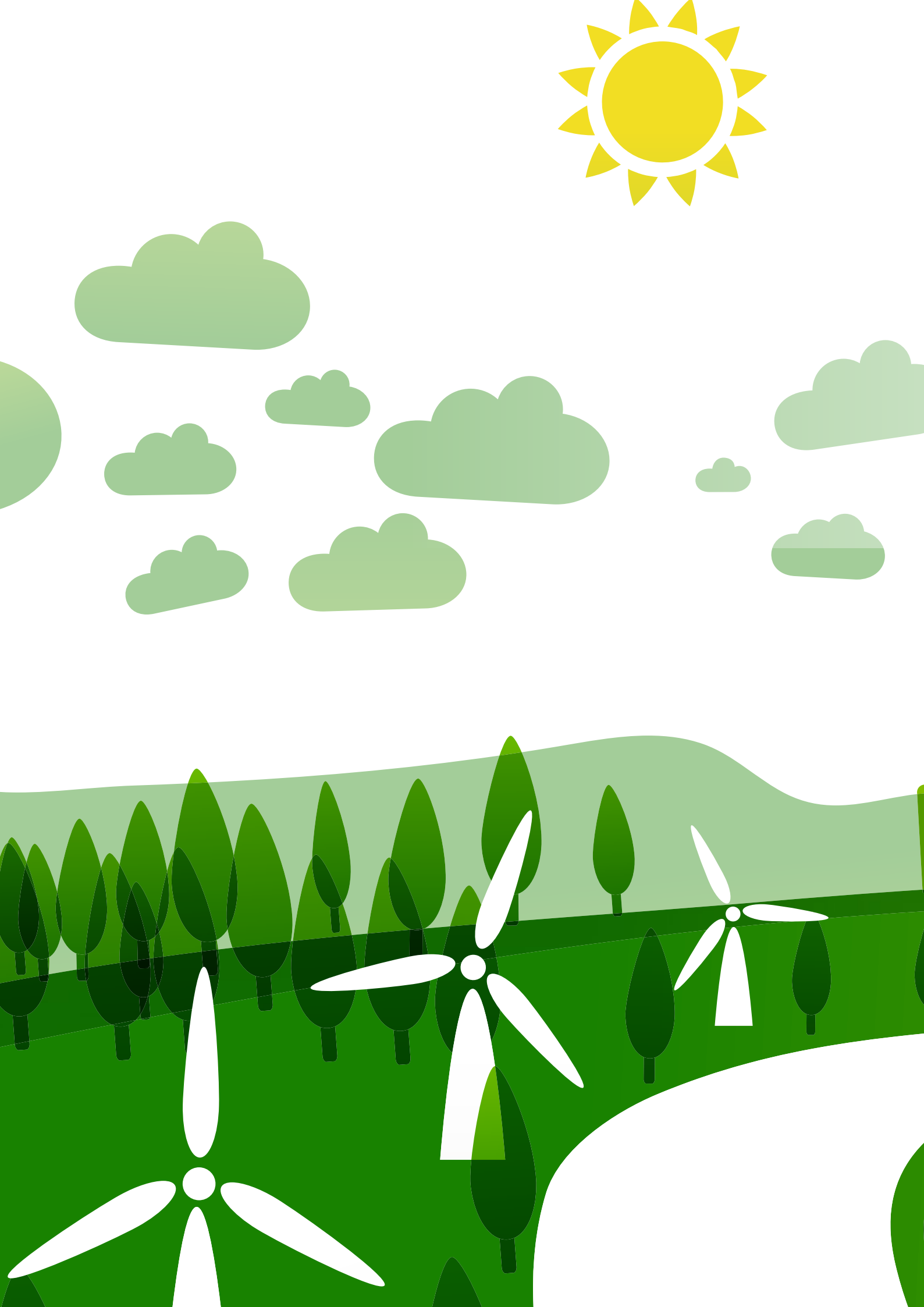
## Bibliography

- [1] FG SSC-0005, *White paper of smart city from CIC and SC forum of China (2013)*.
- [2] FG SSC-0014, *Smart Cities and Smart Statistics (2013)*.
- [3] Smart city in China, *8th ITU Symposium on ICT, Environment and Climate Change, Turin, 6-7 May 2013*.
- [4] European smart cities, <http://www.smartcities.edu/>
- [5] ISO/TC 268/SC1 – Smart Community Infrastructures, [http://www.itu.int/en/ITU-T/jca/ictcc/Documents/docs-2013/Yoshiakilchikawa\\_JCA\\_Feb2013.pdf](http://www.itu.int/en/ITU-T/jca/ictcc/Documents/docs-2013/Yoshiakilchikawa_JCA_Feb2013.pdf)
- [6] IDC smart cities index.
- [7] What exactly is a smart city? <http://www.fastcoexist.com/1680538/what-exactly-is-a-smart-city>
- [8] FG SSC-0034, *KPIs of SSC (2013)*.
- [9] FG SSC-0066-r2, *A case study of KPIs evaluation of the field trial in Mitaka-city (2013)*.
- [10] FG SSC-0030, *Key performance indicators (KPIs) and metrics of Smart Sustainable Cities (2013)*.
- [11] FG SSC-0057, *Key performance indicators (KPIs) and metrics of Smart Sustainable Cities (2013)*.
- [12] FG SSC-0067, *Comments on the document numbered fg-ssc-0057-KPIs (2013)*.
- [13] FG SSC-0068, *Comments on Key performance indicators of SSC (2013)*.
- [14] FG SSC-0072, *Proposal of revising KPIs document FG-SSC-0057 (2013)*.
- [15] FG-SSC-0058, *Smart Cities and Smart Statistics (2013)*.
- [16] FG-SSC-0076, *Proposal from Italy on document SSC-0057-rev-1 (2013)*.
- [17] FG-SSC-0094-r1, *Proposal of revising clause 5, 6 and Annex A of SSC-0057-r2-KPIs, Key performance indicators (KPIs) and metrics of Smart Sustainable Cities (2014)*.
- [18] FG-SSC-0095, *Comments on SSC-0057-r1-KPIs, Key performance indicators (KPIs) and metrics of Smart Sustainable Cities (2014)*.
- [19] FG-SSC-0116, *Proposal of indicators for WG3 (2014)*.
- [20] FG-SSC-0118, *Examples and proposal on measuring method of KPIs in SSC-0057-rev-1 (2014)*.
- [21] FG-SSC-0130, *Proposal of revising Appendix G of [fg-ssc-0057-r2] on Key Performance Indicators (KPIs) and metrics of Smart Sustainable Cities (2014)*.
- [22] FG-SSC-0124, *Comments on Key performance indicators (KPIs) and metrics of Smart Sustainable Cities (2014)*.
- [23] FG-SSC-0127, *Methodology for KPIs for document FG-SSC-0116 (2014)*.
- [24] FG-SSC-0152, *Proposal of a new Appendix of the draft report on Key Performance Indicators (KPIs) and metrics of Smart Sustainable Cities (2014)*.

- [25] FG-SSC-0160, *Contribution from Avina on Key performance indicators (KPIs) and metrics of Smart Sustainable Cities (fg-ssc-0057-r3) (2014).*
- [26] FG-SSC-0164, *Key performance indicators (KPIs) definitions for Smart Sustainable Cities (2014).*
- [27] FG-SSC-0168, *Comments on SSC-0160 and SSC-0162, Key performance indicators (KPIs) and metrics of Smart Sustainable Cities (2014).*
- [28] FG-SSC-0169, *Comments on SSC-0162 and SSC-0164 documents (2014).*
- [29] FG-SSC-0178, *Simulation KPIs – Italy (2014).*
- [30] FG-SSC-0181-r1, *Proposed restructuring and development of KPIs (2014).*
- [31] FG-SSC-0188, *Comments on "Key performance indicators (KPIs) definitions for Smart Sustainable Cities" [fg-ssc-0162-r2] (2014).*
- [32] FG-SSC-0198, *Contribution on KPIs definition [fg-ssc-0162-r2] from Fiberhome Technologies Group (2014).*







**Paving the way  
for Smart  
Sustainable  
Cities**

**5**









# 5.1

## Standardization roadmap for smart sustainable cities

Technical Report

## Acknowledgements

This Technical Report was researched and written by Ziqin Sang (Fiberhome Technologies Group), Zhen Luo (Fiberhome Technologies Group) and Michael Mulquin (IS Communications Ltd) as a contribution to ITU-T Focus Group on Smart Sustainable Cities (FG-SSC).

The authors wish to extend their gratitude to Flavio Cucchiatti (Telecom Italia), Jinghua Min (China Electronic Cyberspace Great Wall Co., Ltd) and Francesco Dadaglio (International Organization for Standardization) for their valuable inputs and support.

The authors acknowledge the guidance and support from all the members of the ITU-T Focus Group on Smart Sustainable Cities (FG-SSC) Management Team.

Additional information and materials relating to this report can be found at: [www.itu.int/itu-t/climatechange](http://www.itu.int/itu-t/climatechange). If you would like to provide any additional information, please contact Cristina Bueti at [tsbsg5@itu.int](mailto:tsbsg5@itu.int).

## Table of Contents

		Page
<b>1</b>	<b>Scope.....</b>	<b>926</b>
<b>2</b>	<b>Definitions.....</b>	<b>926</b>
	2.1 Terms defined elsewhere.....	926
<b>3</b>	<b>Framework of SSC standards .....</b>	<b>926</b>
<b>4</b>	<b>SSC-related SDOs activities .....</b>	<b>928</b>
	4.1 Overview .....	928
	4.2 Challenges .....	929
	4.3 Types of standardization work.....	930
<b>5</b>	<b>Outline of SSC standard needs and gap analysis .....</b>	<b>931</b>
	5.1 Smart sustainable city service standards.....	931
	5.2 Information and communication technology standards .....	939
	5.3 Management and assessment standards .....	944
	5.4 Building and physical infrastructure standards .....	946
	<b>Abbreviations.....</b>	<b>951</b>
	<b>Bibliography .....</b>	<b>954</b>





## Standardization roadmap for smart sustainable cities

### Executive summary

This Technical Report is a deliverable of the ITU-T Focus Group on Smart Sustainable Cities (FG-SSC), and is one of two Technical Reports on standardization activities, gap analysis, roadmap and suggestions to ITU study groups for smart sustainable cities (SSC). The report is intended to outline a concise roadmap of standardization on the content provided in the “Technical Report on standardization activities for smart sustainable cities”.

This Technical Report proposes a framework of standards which are needed for the life-cycle of building SSC. By classifying four categories and several areas in each category of standards, the SSC-related standard needs are offered as “tasks” in every area. The corresponding gaps are analyzed, and relevant standards developing organizations (SDOs), consortia and forums are listed as “relationships”.

This Technical Report is structured around four main sections. Section one provides the scope of the report. Section five proposes a framework of standards, four structured categories (i.e. SSC management and assessment, SSC services, ICT, buildings and physical infrastructure). Section six presents SSC related SDOs activities. Section seven outlines SSC-related standard needs, gap analysis and relevant study groups of SDOs, consortium and forums.

The standardization roadmap presented in this Technical Report provides a valuable suggestions to ITU-T SG5 for future work on SSC. It also helps other study groups of ITU and SDOs to understand the areas of the set of FG-SSC deliverables that can serve as the basis for the development of standards in this field.

## 1 Scope

---

This Technical Report proposes a framework of standards for smart sustainable cities (SSC) and provides a standardization roadmap, taking into consideration the activities currently undertaken by the various standards developing organizations (SDOs) and forums.

The main objective is to provide suggestions for potential standardization activities to ITU-T Study Group 5 (SG5), but it is hoped that it could also be the basis for a wider standardization roadmap involving other ITU groups and other SDOs.

## 2 Definitions

---

### 2.1 Terms defined elsewhere

This Technical Report uses the following terms defined elsewhere:

**3.1.1 city** [ITU-T L.KPIs-overview]: An urban geographical area with one (or several) local government and planning authorities.

**3.1.2 smart sustainable cities** [ITU-T TR SSC Def]: A smart sustainable city is an innovative city that uses information and communication technologies (ICTs) and other means to improve quality of life, efficiency of urban operation and services, and competitiveness, while ensuring that it meets the needs of present and future generations with respect to economic, social, environmental as well as cultural aspects.

## 3 Framework of SSC standards

---

Standards for smart sustainable cities can be generally classified into four categories (Figure 1):

1. Smart city management and assessment:
  - strategic planning and partnership building;
  - deployment and implementation;
  - management and administration;
  - resilience and disaster recovery;
  - evaluation and assessment.
2. SSC services:
  - e-government;
  - transport;
  - logistics;
  - public safety;
  - health care;
  - governance of urban infrastructure;
  - energy and resources management;
  - environmental protection;
  - climate change adaptation;
  - community and household.

3. Information and communication technology (ICT):
  - ICT framework, architecture and information model;
  - network and information security, availability and resilience;
  - application and support layer;
  - data layer;
  - communication layer;
  - sensing layer.
4. Buildings and physical infrastructure:
  - urban planning;
  - low carbon design and construction;
  - intelligent building systems;
  - building information modelling (BIM);
  - traffic systems;
  - urban pipeline network.

In addition, it is important to develop a set of definitions for key terms relating to smart sustainable cities within and across each of these four categories of standards.

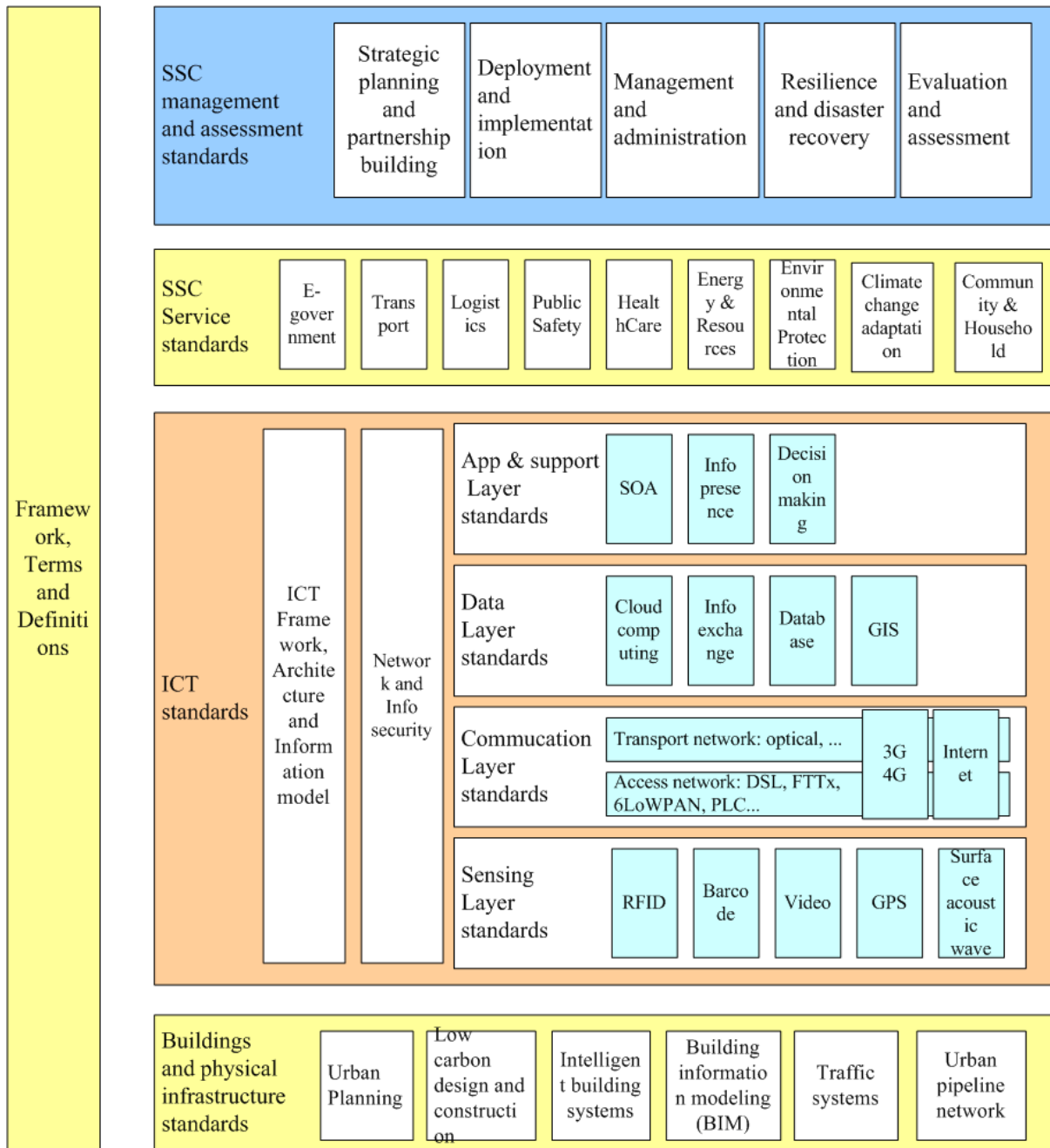


Figure 1 - Framework of SSC standards

## 4 SSC-related SDOs activities

### 4.1 Overview

The traditional standards related to SSC have been mostly developed by technical-specific organizations through “vertical” approaches. As a result, those standards only cover the technical aspects of SSC, which undermines their authority and leads to questions about their validity.

Moreover, the original models of the "digital city", "wireless city", "broadband city" or "optical city" had a strong technical focus on information and communication technologies (ICTs). These models



were not following a broad and horizontal strategy, and sector-specific vertical approaches were based on separate infrastructures, not interworking with each other while often physically overlapping. None of these models can satisfy the complex and comprehensive requirement of future urban management and sustainable development.

Therefore, the original digital systems, as well as the traditional ICT standards, should be improved or redesigned from a broader and higher level perspective, to achieve the transformational impact that smart sustainable cities ought to bring about.

The development of SSC standards can be accomplished through cooperation among standards organizations and the adaptation of existing standards, fulfilling the principle of openness, compatibility and versatility.

## 4.2 Challenges

In considering the work required to develop SSC standards, it is important to take two key issues into consideration:

- In addition to ITU-T, a number of other important standards bodies are working to scope out and develop SSC standards.
- While international SDOs including ITU are already developing standards in many of the key technology areas related to smart and sustainable cities, those standards may not necessarily reflect the complexity of dealing with a smart and sustainable city as a system of systems, and the specific challenges that this brings. Development of broader perspective and coordination and collaboration among SDOs will enable earlier and more effective development of ICT infrastructure.

These two factors indicate the following challenges regarding SSC standards that need to be addressed:

- The necessity to fulfil the needs of city sustainability in social, economic and environmental aspects.
- The need to ensure interoperability between different city systems.
- The need to take into account the challenges of complex organizational requirements, including interfaces between the public sector and commercial organizations, and among commercial organizations.
- The need for the city to be able to manage issues such as privacy, cyber-security, resilience, and data flows on a whole-system basis.
- The need of non-specialist city leadership to be able to understand the many, complex and interrelating ICT issues relating to the move towards a smarter and more sustainable city and how to put together the right portfolio of standards requirements to ensure that their projects are able to succeed.
- The need to ensure that standards being developed by study groups within ITU take into account the requirements of smart and sustainable cities.
- The need to ensure consistency with SSC standards being developed by other international standards bodies.
- The need to ensure standards organizations are connected with basic (non-ICT) technical areas to understand their needs and develop proper solutions.



### 4.3 Types of standardization work

Given the challenges identified above, there are a number of types of SSC standards-related work that could potentially be undertaken by ITU and that could support cities in becoming smarter and more sustainable:

- developing standards related to ensuring interoperability and coherence between different city systems and to enable cities to assess progress and benefits from smart city initiatives
- studying SSC-related issues (such as city security, city resilience, privacy and data protection, etc.) in partnership with the related study groups and focus groups within ITU to:
  - (a) identify if there are any gaps in the existing standards relating to those issues so that these gaps can then be tackled by the related standards groups;
  - (b) develop guidelines for city leadership on how to bring together the appropriate portfolio of the related standards in that area that will enable the standards groups to tackle that issue.
- developing guides that match the suitability of the various ICT techniques to the plenty of services a smart sustainable city needs, highlighting best practices available.
- developing guidelines of the key technologies and trends which can have an impact in implementing the smart sustainable city strategies, in partnership with the related study groups and focus groups within ITU, aimed at SSC practitioners, to help them understand the relevance of these technologies and trends, and the standards underpinning them.
- liaising with related ITU study groups and focus groups and with other international standards bodies, potentially in partnership with ISO/TMB SAG on Smart Cities and IEC/SMB SEG 1 on Smart Cities, to:
  - (a) ensure that standards are being developed in technologies related to smart and sustainable cities, and within individual city systems, and take into account any specificity relating to smart and sustainable cities;
  - (b) identify developing good practices that might be developed into ITU standards;
  - (c) support co-ordination of international work on SSC standards to avoid overlaps and ensure greater consistency between the standards that are developed.

A document of ITU-T FG-SSC provides a list of standards that have already been developed in the area of smart and sustainable cities, a description of the work that other standards bodies are doing in this area and a summary of key networks and initiatives that are developing good practice and guidelines for cities [ITU-T TR standard].

## 5 Outline of SSC standard needs and gap analysis

This section outlines the task of future standardization work, the existing gaps and organizations where potentially collaboration could be sought for each aspect proposed in Figure 1.

### 5.1 Smart sustainable city service standards

#### 5.1.1 E-government

##### 5.1.1.1 Task

The standardization of e-government should support the services related to government affairs that are provided to city residents.

NOTE 1– The technologies of e-government include, but are not limited to, information sharing, electronic document sharing, and data directory service.

The tasks include, but are not limited to:

- developing guidelines for the services of e-government related to SSC that include: online city information availability, online civic engagement, online support for new city residents, strategies to enable ICT literacy of residents, etc.
- developing a series of technical standards including the terms and definitions, service models, information management, and safety and security, etc., in the e-government of SSC.
- providing the necessary collaboration for joint activities in this field between ITU-T and SDOs conducting related work on SSC, consortia and forums.

NOTE 2 – [ITU-T TR management] explains the services of e-government in SSC.

NOTE 3 – There are some fundamental standards on information technologies in ISO/IEC, including:

- vocabulary;
- metadata registries;
- software product evaluation;
- security techniques (evaluation criteria for information technology (IT) security, digital signatures with appendix, entity authentication, non-repudiation);
- open systems interconnection (security frameworks for open systems, systems management).

NOTE 4 – There are some fundamental standards on data exchange service, including:

- office automation;
- real-time information releasing;
- transparency around governmental decision-making and open data;
- electronic public-opinion polling.

##### 5.1.1.2 Gap

Standards linked to the above mentioned e-government services are still required in the following area:

- government project that benefit the municipalities and residents (emergency response, decision making, etc.).

### 5.1.1.3 Relationships

ISO/IEC.

ISO/IEC JTC1 (Information Technology).

### 5.1.2 Transport

#### 5.1.2.1 Task

The standardization of transport issues in SSC should fulfil the requirements of passengers, drivers, vehicles, traffic infrastructures, etc.

NOTE 1 – The services of city transport system include but are not limited to: traffic information services, traffic telematics, information exchange between vehicle to vehicle (V2V), vehicle to infrastructure (V2I), and vehicle to everything (V2X), and traffic emergency processing.

The tasks include, but are not limited to:

- developing guidelines for integrated services within SSC intelligent transport systems.
- developing Recommendations for guidelines and best practices related to the services and functional requirements of the traffic emergency processing for SSC.
- developing Recommendations for guidelines and best practices related to the implementation of SSC mobility and transport services with a view to addressing environmental challenges.
- providing the necessary collaboration for joint activities in this field between ITU-T and SDOs, consortia and forums conducting related work on SSC.

NOTE 2 – [ITU-T TR infrastructure] discusses ICT infrastructure in SSC which involves facilities of Internet of things (IoT). There are several technical committees (TCs) working on traffic/transport standardization in ISO/IEC.

#### 5.1.2.2 Gap

The standards related to the transport services mentioned above are still required in the following areas:

- integrated service within intelligent transport system (ITS);
- information exchanges of networked vehicles;
- energy efficiency of transport for SSC.

### 5.1.2.3 Relationships

ITU-T FG CarCom (Focus Group on From/In/To Cars Communication).

ITU-T FG Distraction (Focus Group on Driver Distraction).

ITU-T CITS (Collaboration on ITS Communication Standards).

ITU-T Q12/SG13 (Distributed service networking).

ITU-T Q4c/SG15 (PEV communications).

ITU-T Q27/16 (Vehicle gateway platform for telecommunication/ITS services /applications).

ISO/TC 241 (Road traffic safety management systems).

ISO/TC 204 (Intelligent transport systems).

ISO/TC 22 (Road vehicles).

### 5.1.3 Logistics

#### 5.1.3.1 Task

The standardization of logistics in SSC should fulfil the service requirements related to consignor, consignee, carriers, goods, and warehouses.

The tasks include, but are not limited to:

- developing guidelines for integrated services regarding logistics in SSC, including: supply chain services, business intelligence, and electronic payments etc.
- developing Recommendations for guidelines and best practices related to the implementation of logistics services with a view to addressing environmental challenges.
- providing the necessary collaboration for joint activities in this field between ITU-T and SDOs conducting related work on SSC, consortia and forums.

NOTE – The “GS1 Standard 1” focuses on the management of objects in the supply chain and is widely accepted as an international standard.

#### 5.1.3.2 Gap

Standards related to the above mentioned logistics services are still required in the following areas:

- integrated services of logistics in SSC;
- energy efficiency of logistics for SSC.

#### 5.1.3.3 Relationships

Globe Standard 1.

ISO International Workshop Agreement (IWA) *International harmonized method(s) for a coherent quantification of CO<sub>2</sub>e emissions of freight transport.*

### 5.1.4 Public safety

#### 5.1.4.1 Task

The standardization of public safety in SSC should fulfil the service requirements of citizens.

NOTE 1– The services of public safety for SSC include, but are not limited to: crime reduction, tackling natural and man-made disasters, and emergency response.

The tasks include, but are not limited to:

- developing guidelines for services relating to public safety and security in SSC, including: crime reduction, anti-terrorism, disasters management, emergency response, etc.
- developing guidelines relating to measures and facilities of public safety and security in SSC, such as: flood control, fire control, food and drug quality tracing, etc.
- providing the necessary collaboration for joint activities in this field between ITU-T and SDOs, consortia and forums conducting related work on SSC.

NOTE 2 – [ITU-T TR overview] provides an overview of SSC and roles of ICT which involves disasters alert for SCC.

NOTE 3 – ISO/TC 223 worked on the organizational resilience, business continuity and emergency management in societal security. Now TC 223 has been merged into a larger TC - ISO/TC 292 (security).

#### 5.1.4.2 Gap

Standards relating to the services of public safety mentioned above are still required in the following area:

- integrated management of public safety and security.

#### 5.1.4.3 Relationships

ITU-T FG-SWM (Focus Group on Smart Water Management).

ISO/TC 292 (Security).

ISO/PC 278 (Anti-bribery management systems).

ISO/TC 262 (Risk management).

#### 5.1.5 Health care

##### 5.1.5.1 Task

The standardization of health care in SSC should fulfil the service requirements of city residents, patients, hospitals, and health centres.

NOTE 1 – The services of health care include but are not limited to: e-health monitoring services, health informatics, medical informatics, and telemedicine.

The tasks include, but are not limited to:

- developing guidelines for services related to health care in SSC based on the existing health care related standards, including: electronic health records, electronic medical records, medical resources and information sharing, telemedicine, etc.
- developing guidelines for the system and interfaces with existing health care related standards.
- developing guidelines for the strategy of improving resident health such as: mitigation of exposure to the electromagnetic field (EMF), noise, pollution, etc.
- providing the necessary collaboration for joint activities in this field between ITU-T and SDOs, consortia and forums conducting related work on SSC.

NOTE 2 – WHO, CEN/TC 251, ISO/TC 215, ITU-T SG13, and ITU-T FG M2M are working on all aspects of health care standards covering areas from doctors and nurses to patients, from hospitals to home and electromagnetic fields. These standards are widely used in the health care industry.

##### 5.1.5.2 Gap

Standards related to the health care services mentioned above are still required in the following area:

- management of public health care issues in SSC.

##### 5.1.5.3 Relationships

ITU-T SG13 (Future networks, including cloud computing, mobile and next-generation networks).

ITU-T FG M2M (Focus Group on Machine-to-Machine Service Layer).

ISO/PC 283 (Occupational health and safety management systems)

ISO/TC 215 (Health informatics).

IEC TC108 (Safety of electronic equipment).

WHO.

CEN/TC 251 (Health informatics).

HL7.

## 5.1.6 Governance of urban infrastructure

### 5.1.6.1 Task

The standardization of the governance of urban infrastructure in SSC should fulfil the service requirements of city infrastructures.

NOTE 1 – The city infrastructure includes but is not limited to: road transport, street lighting, urban landscape, and urban underground pipelines.

The tasks include, but are not limited to:

- developing guidelines for services related to urban governance in SSC based on the existing urban governance standards.
- developing guidelines for the system and interfaces based on the existing urban governance application in SSC.
- developing Recommendations for integrated management in SSC (high level requirements, framework, meta-model, data fusion, management services, cooperation in creation of infrastructure and sharing among service providers etc.).
- providing the necessary collaboration for joint activities in this field between ITU-T and SDOs, consortia and forums conducting related work on SSC.

NOTE 2 – There are some technical reports on integrated management and corresponding best practices in FG- SSC which concentrate on decision making, urban operations and services [ITU-T TR management] [ITU-T TR water].

NOTE 3 – ISO TC 268 is working on the management of smart community infrastructures. Also, some national organizations, such as The American Society of Civil Engineers (ASCE) and their counterpart in China (Standardization Administration of China (SAC)), have this kind of standards and technical documents.

### 5.1.6.2 Gap

Standards related to the governance of urban infrastructures, as mentioned above, are still required in the following area:

- integrated management of SSC (high-level requirements, framework, meta-model, data fusion, management services, cooperation in creation of infrastructure and sharing among service providers etc.).

### 5.1.6.3 Relationships

ISO/TC 268 (Sustainable development in communities).

ISO/TC 176 (Quality management and quality assurance)<sup>1</sup>.

ASCE (The American Society of Civil Engineers).

SAC/TC426 (Digital Technique of Intelligent Building and Residence Community).

## 5.1.7 Energy and resources management

### 5.1.7.1 Task

The standardization of energy and resources management should fulfil the service requirements of industries, residential dwellings and public facilities related to energy and resources management in SSC.

---

<sup>1</sup> Please see ISO 18091.



NOTE 1 – The energy and resources management includes, but is not limited to: power supply, water supply and sanitation, oil supply, gas supply, and city minerals.

The tasks include, but are not limited to:

- developing guidelines for energy consumption in SSC (data collection, statistics, analysis, etc.).
- developing guidelines for resources supervision in SSC.
- developing guidelines for energy efficiency in SSC.
- developing Recommendations for methodology of energy evaluation in the household.
- providing the necessary collaboration for joint activities in this field between ITU-T and SDOs, consortia and forums conducting related work on SSC.

NOTE 2 – ISO, IEC and ITU-T are working on the smart grid and smart metering in energy and resources management as well as on energy efficiency. However, since the scope and boundary of the standards are not limited to the region of a city, more efforts related to integrated energy and resources management, including power, gas, water and sanitation in cities, are required.

#### 5.1.7.2 Gap

Standards related to the services of energy and resources management mentioned above are still required in the following area:

- integrated energy and resources management of SSC (monitoring, statistic, analysis, etc.)

#### 5.1.7.3 Relationships

ITU-T FG Smart Grid (Focus Group on Smart Grid).

ITU-T WP3/SG5 (ICT and climate change).

ITU-T Q25/SG16 (IoT application and services).

ISO/TC 282 (Water re-use).

ISO/TC 275 (Sludge recovery, recycling, treatment and disposal).

ISO/TC 265 (Carbon dioxide capture, transportation, and geological storage).

ISO/TC 257 (Evaluation of energy savings).

ISO/TC 255 (Biogas).

ISO/PC 248 (Sustainability criteria for bioenergy).

ISO/TC 242 (Energy Management).

ISO/TC 238 (Solid biofuels).

ISO/TC 224 (Service activities relating to drinking water supply systems and wastewater systems - Quality criteria of the service and performance indicators).

ISO/TC 180 (Solar energy).

ISO/TC 163 (Thermal performance and energy use in the built environment).

ISO/TC 85 (Nuclear energy, nuclear technologies, and radiological protection).

ISO/IEC JTC 1/SG 1 (Information Technology/Smart Cities).

IEC TC 57 (Power systems management and associated information exchange).

CEN/CENELEC/ETSI Joint Working Group on Smart Grid.

CEN/CENELEC/ETSI Joint Working Group on Smart Meters.

## 5.1.8 Environmental protection

### 5.1.8.1 Task

The standardization of environmental protection should fulfil the service requirements of industries and residential dwellings related to environmental protection in SSC.

NOTE – The services of environmental protection include but are not limited to: EMF, solid waste management, e-waste management, pollution source monitoring, toxic substance monitoring, and noise monitoring.

The tasks include, but are not limited to:

- developing Recommendations for integrated environmental assessment in SSC (EMF, solid waste management, e-waste management, pollution source monitoring, toxic substance monitoring, noise monitoring).
- developing guidelines for exposure to environment pollution (EMF, chemicals, radiation, noise, etc.).
- providing the necessary collaboration for joint activities in this field between ITU-T and SDOs, consortia and forums conducting related work on SSC.

### 5.1.8.2 Gap

Standards related to the services of environmental protection mentioned above are still required in the following areas:

- integrated environmental assessment;
- exposure to environment pollution.

### 5.1.8.3 Relationships

ITU-T WP3/SG5 (ICT and climate change).

ISO/TC 282 (Water re-use).

ISO/TC 275 (Sludge recovery, recycling, treatment and disposal).

ISO/TC 265 (Carbon dioxide capture, transportation, and geological storage).

ISO/PC 248 (Sustainability criteria for bioenergy).

ISO/TC 207 (Environmental management).

## 5.1.9 Climate change

### 5.1.9.1 Task

Standardization related to climate change should fulfil the service requirements of industries related to climate change in SSC.

NOTE 1 – The services of ICT and climate change for SSC include, but are not limited to: tackling climate change in cities.

The tasks include, but are not limited to:

- developing guidelines for climate change assessment (adaption and mitigation) in SSC.
- developing guidelines for ICT use in GHG emissions.
- providing the necessary collaboration for joint activities in this field between ITU-T and SDOs, consortia and forums conducting related work on SSC.

NOTE 2 – [ITU-T TR climate] discusses climate change adaption in cities.

### 5.1.9.2 Gap

Standards required related to the services of climate change mentioned above are still required in the following areas:

- climate change assessment (adaption and mitigation) in SSC;
- ICT use in GHG emissions.

### 5.1.9.3 Relationships

ITU-T WP3/SG5 (ICT and climate change).

UNFCCC.

ISO Climate Change Coordinating Committee (CCCC).

### 5.1.10 Districts

#### 5.1.10.1 Task

Standardization related to districts should fulfil the service requirements of residents, and communities in SSC.

The tasks include, but are not limited to:

- developing Recommendations for smart districts, including scenarios, use cases, best practices, and security etc.
- developing Recommendations for smart communities with linkage to e-government, public safety, emergency response, healthcare, energy and resources management, etc.
- providing the necessary collaboration for joint activities in this field between ITU-T and SDOs, consortia and forums conducting related work on SSC.

#### 5.1.10.2 Gap

Standards related to the services of districts, mentioned above, are still required in the following areas:

- smart districts;
- smart community interface to e-government, public safety, emergency response, health care, energy and resources management, etc.

#### 5.1.10.3 Relationships

ISO/TC268/SC 1 (Sustainable development in communities/Smart community infrastructures).

### 5.1.11 Buildings and residential dwellings

#### 5.1.11.1 Task

The standardization of buildings and residential dwellings should fulfill the service requirements of public buildings and dwellings in SSC.

NOTE 1 – The services of public building and residential dwellings include, but are not limited to: building information modelling, and building automation.

The tasks include, but are not limited to:

- developing Recommendations for buildings and residential dwellings, including scenarios, use cases, best practices, and security, etc.

- developing Recommendations for smart homes with linkage to safety and security, emergency response, entertainment, tele-medicine, etc.
- developing Recommendations for smart buildings and homes with linkage to resources management including distributed and renewable energy, etc.
- providing the necessary collaboration for joint activities in this field between ITU-T and SDOs, consortia and forums conducting related work on SSC.

NOTE 2– [b-FG- SSC building] concentrates on ICT impact on building and household.

#### 5.1.11.2 Gap

Standards related to the building and residential dwellings mentioned above are still required in the following areas:

- smart homes with linkage to safety and security, emergency response, entertainment, tele-medicine, etc.
- smart buildings and home with linkage to resources management including distributed and renewable energy, etc.

#### 5.1.11.3 Relationships

ITU-T SG5 (Environment and climate change).

ITU-T SG15 (Networks, technologies and infrastructures for transport, access and home).

ITU-T SG16 (Multimedia coding, systems and applications).

ISO/TC 205/WG3 (Building environment design/Building Automation and Control System (BACS) Design).

ISO/TC 59 (Buildings and civil engineering works).

## 5.2 Information and communication technology standards

### 5.2.1 SSC framework, architecture and information model

#### 5.2.1.1 Task

The standardization of SSC framework, architecture and information model should be based on and expand the related ICT standards, supporting the development of SSC.

The tasks include, but are not limited to:

- developing ITU-T Recommendations for:
  - terms and definitions related to SSC from an ICT perspective;
  - characteristics, high-level requirements and general capabilities of SSCs;
  - information model of SSC from a spatio-temporal perspective;
  - ICT infrastructure/services available in SSC/ architecture framework and technical requirements of SSC;
- developing ITU-T Recommendations on: guidelines, methodologies and best practices to help cities to deliver ICT services including (but not limited to) integrated management, IoT, big data and open data with a view to addressing social, economic, and environmental challenges.
- providing the necessary collaboration for joint activities in this field between ITU-T and SDOs, consortia and forums conducting relevant work on SSC.

NOTE – There are several technical reports on SSC terms and definitions, characteristics and attributes, and infrastructure which concentrate on ICT infrastructure in FG SSC [ITU-T TR SSC Def] [ITU-T TR overview] [ITU-T TR infrastructure].

#### 5.2.1.2 Gap

Standards related to the above framework, architecture and information model technologies are still required in the following areas:

- terms and definitions;
- characteristics, high-level requirements and general capabilities;
- spatio-temporal information model;
- ICT infrastructure/architecture framework and technical requirements;
- guidelines, methodologies and best practices to help cities deliver ICT services including integrated management, IoT, big data and open data.

#### 5.2.1.3 Relationships

ITU-T SG5 (Environment and climate change).

ISO TC 268/SC 1 (Sustainable development in communities/ Smart community infrastructures).

ISO/TMB SAG Smart Cities (Strategic Advisory Group on Smart Cities).

ISO/IEC JTC1/SG 1 (Information Technology/Smart Cities).

IEC/SMB SEG 1 (Systems Evaluation Group - Smart Cities).

### 5.2.2 Network and information security

#### 5.2.2.1 Task

The standardization of network and information security should be based on and expand on the related ICT standards, supporting the security requirements of SSC.

The task includes but is not limited to:

- developing guidelines for network and information security in SSC.

NOTE – [ITU-T TR security] concentrates on Cyber-security, data protection and cyber-resilience in SSC.

#### 5.2.2.2 Gap

Standards related to the above network and information security are still required in the following areas:

- overall cybersecurity in SSC;
- SSC service continuity.

#### 5.2.2.3 Relationships

ITU-T SG17 (Security).

ISO/IEC JTC 1/SC 27 (Information Technology/Security techniques).

### 5.2.3 Sensing layer standards

#### 5.2.3.1 Task

The standardization of the following technologies should be implemented in the sensing layer of SSC:

- IEEE 1451 Smart Transducer Interface.
- ISO/IEC JTC 1 SC 31 and AIM PDF417 Barcode Symbols.
- ISO/IEC JTC 1 SC 31 and EPC global RFID.
- ZigBee
- IPv6 over low power wireless personal area networks (6LoWPAN).
- Wireless MBus.
- Global positioning system (GPS).
- Video surveillance.
- Smart metering.

The tasks include, but are not limited to:

- developing guidelines for the application of smart transducer interface in SSC.
- developing guidelines for the interface of barcode symbols in SSC.
- developing guidelines for the interface of radio frequency identification (RFID) in SSC.
- developing guidelines for the gateway of ZigBee/6LoWPAN in SSC.
- developing guidelines for the gateway of Wireless MBus.
- developing guidelines for the interface of Global Positioning System in SSC.
- developing guidelines for the application of video surveillance in SSC.
- developing guidelines for the interface of smart metering with related services in SSC.

#### 5.2.3.2 Gap

Standards related to the SSC sensing are still required in the following areas:

- the set of standards IEEE 1451 is not widely used in the services in SSC, especially in the industrial control field. There are still some standards to be developed related to the interface of smart transducer interface with related SSC services.
- interface standards of barcode symbols systems to provide SSC services.
- interface standards of RFID systems to provide SSC services.
- interface standards of global positioning system. The joint standardization activities of GPS should take into account the requirements of some relevant services in SSC, such as transport, logistics, etc.
- interface standards of video surveillance systems with other ICT systems such as geographic information system (GIS), clouding computing, big data, etc., which take into consideration relevant applications in SSC, such as public safety, urban governance, transport, etc.
- interface standards for smart metering with related services in SSC, such as energy and resources management, environmental protection, climate change, etc.



### 5.2.3.3 Relationships

ISO/IEC JTC 1 SC 31 and AIM

ISO/IEC JTC 1 SC 31 and EPC global

ISO/TC 213 (Dimensional and geometrical product)

IEEE 1451 (Smart Transducer Interface)

IEEE 802.15.4 (Low Rate Wireless Personal Area Networks)

ZigBee Alliance

IETF 6LoWPAN (IPv6 over low power wireless personal area networks)

Network Video Interface Forum

Physical Security Interoperability Alliance

### 5.2.4 Communication layer standards

#### 5.2.4.1 Task

The standardization of the following technologies should be implemented in the communication layer of SSC:

- Ethernet.
- xDSL.
- EPON/GPON.
- SDH/DWDM/OTN.
- GSM/WCDMA/CDMA.
- LTE TDD/FDD.
- EMF.

#### 5.2.4.2 Gap

Standards related to the SSC sensing are still required in the following areas:

- Some technical requirements that should be researched and fulfilled for the IoT and machine to machine (M2M) applications based on the communication layer standards in SSC.

#### 5.2.4.3 Relationships

ITU-T SG15 (Networks, technologies and infrastructures for transport, access and home).

IEEE 802.3 (Ethernet)

3GPP (3rd Generation Partnership Project).

3GPP2 (3rd Generation Partnership Project 2).

### 5.2.5 Data layer standards

#### 5.2.5.1 Task

The standardization of the following technologies should be implemented in the data layer of SSC:

- cloud computing;
- data exchange;
- GIS.

The tasks include, but are not limited to:

- developing guidelines for the interface of data layer standards in SSC.
- developing Recommendations for the future needs of big data, open data etc. supporting various SSC services.

#### 5.2.5.2 Gap

Standards related to the data layer are still required in the following areas:

- big data providing support to various SSC services;
- spatio-temporal framework providing geographical location and navigation for various SSC services.

#### 5.2.5.3 Relationships

ITU-T SG13 (Future networks including cloud computing, mobile and next-generation networks).

ITU-T SG17 (Security).

ISO/TC 68 (Financial services).

ISO/TC 222 (Personal financial planning).

ISO/TC 211 (Geographic information and Geomatics).

DMTF (Distributed Management Task Force).

HL7 (Healthcare Level 7).

OGC (Open Geospatial Consortium).

### 5.2.6 Application and support layer standards

#### 5.2.6.1 Task

The standardization of the following technologies should be implemented in the application and support layer of SSC:

- SOA;
- information presence;
- integrated management;
- decision-making.

NOTE – [ITU-T TR management] tackles the challenges of urban administration in SSC.

The tasks include, but are not limited to:

- developing guidelines for the interface of application and support layer standards in SSC.
- developing guidelines for three dimensional (3D) virtual reality of SSC, city simulation, web services for SSC, etc.

#### 5.2.6.2 Gap

Standards related to the application and support layer are still required in the following areas:

- virtual reality;
- city simulation;
- web service for SSC.

### 5.2.6.3 Relationships

SIGGRAPH (Special Interest Group for Computer GRAPHICS).

OGC (Open Geospatial Consortium).

W3C (World Wide Web Consortium).

## 5.3 Management and assessment standards

### 5.3.1 Strategic planning and partnership building

#### 5.3.1.1 Task

The standardization of the following technologies should be implemented in the strategic planning and partnership building of SSC.

The tasks include, but are not limited to:

- developing guidelines and best practices for the requirements analysis in SSC.
- developing guidelines and best practices for the strategic planning mechanisms and methods in SSC.
- developing guidelines and best practices for the partnership building mechanisms and methods in SSC.

#### 5.3.1.2 Gap

Standards related to the strategic planning and partnerships building in SSC are still required in the following area:

- mechanism and methods for the strategic planning and partnership building.

NOTE – There is a strategy report on "building SSC" in FG-SSC [ITU-T TR leaders].

#### 5.3.1.3 Relationships

ISO/TMB SAG SCities (Strategic Advisory Group on Smart Cities).

IEC/SMB SEG 1 (Systems Evaluation Group - Smart Cities).

ISO/IEC JTC 1/SG 1 (Information Technology/Smart Cities).

## 5.3.2 Deployment and implementation

#### 5.3.2.1 Task

The standardization of the following issues should be implemented in the deployment and implementation of SSC.

The tasks include, but are not limited to:

- developing guidelines and best practices for the deployment procedures in SSC.
- developing guidelines and best practices for the implementation procedures in SSC.

NOTE – A document on investment in SSC is also very important.

#### 5.3.2.2 Gap

Standards related to the deployment and implementation in SSC are still required in the following area:

- procedure for the deployment and implementation.

### 5.3.2.3 Relationships

ITU-T SG2 (Operational aspects of service provision and telecommunications management).

DMTF (Distributed Management Task Force).

### 5.3.3 Management and administration

#### 5.3.3.1 Task

The standardization of the following technologies should be implemented in the management and assessment of SSC.

The tasks include, but are not limited to:

- developing a code of conduct for the management in SSC.
- developing a code of conduct for the administration in SSC.

#### 5.3.3.2 Gap

Standardization related to the management and administration in SSC are still required in the following area:

- code of conduct for management and administration.

#### 5.3.3.3 Relationships

ISO/TC 176 (Quality management and quality assurance)<sup>2</sup>.

### 5.3.4 Resilience and disaster recovery

#### 5.3.4.1 Task

The standardization of the following areas should be implemented in the management and assessment of SSC.

The tasks include, but are not limited to:

- developing guidelines and best practices for the resilience in SSC.
- developing guidelines and best practices for the disaster recovery in SSC.

#### 5.3.4.2 Gap

Standards related to the resilience and disaster recovery in SSC are still required in the following areas:

- identification of inter-relations among the various services impacting resilience and disaster recovery in an SSC.
- procedure and methods for the resilience and disaster recovery.

#### 5.3.4.3 Relationships

ITU-T FG DR&NRR (Focus Group on Disaster Relief Systems, Network Resilience and Recovery).

---

<sup>2</sup> Please see ISO 18091.

### 5.3.5 Evaluation and assessment

#### 5.3.5.1 Task

The standardization of the following areas should be implemented in the management and assessment of SSC.

NOTE – There are several technical report and technical specifications on key performance indicators of information and communication technologies for smart sustainable cities developed by FG SSC [ITU-T L.KPIs-overview] [ITU-T L.KPIs-ICT] [ITU-T L.KPIs-impact] [ITU-T L.KPIs-Supp].

The task include, but is not limited to:

- developing Recommendations for the methodology of evaluation and assessment for SSC.

#### 5.3.5.2 Gap

Standards related to the evaluation and assessment in SSC are still required in the following areas:

- methodology of evaluation;
- metrics of evaluation.

#### 5.3.5.3 Relationships

ITU-T SG5 (Environment and climate change).

ISO/TMB SAG SCities (Strategic Advisory Group on Smart Cities).

IEC/SMB SEG 1 (Systems Evaluation Group - Smart Cities).

## 5.4 Building and physical infrastructure standards

### 5.4.1 Urban planning

#### 5.4.1.1 Task

The standardization of the following technologies should be implemented in the urban planning of SSC:

- building SSC from an urban planning perspective

Tasks include but are not limited to:

- developing guidelines and best practices for urban planning in SSC.
- developing guidelines for the essential technologies for urban planning such as GIS, electronic maps.

#### 5.4.1.2 Gap

Standards related to the urban planning in SSC are still required in the following areas:

- city geo-information infrastructure for urban planning

#### 5.4.1.3 Relationships

ISO/TMB SAG SCities (Strategic Advisory Group on Smart Cities).

IEC/SMB SEG 1 (Systems Evaluation Group - Smart Cities).

OGC (Open Geospatial Consortium).

## 5.4.2 Low carbon design and construction

### 5.4.2.1 Task

The standardization of the following areas should be implemented in the low carbon design and construction of SSC:

- energy conservation;
- waste recycling.

The tasks include, but are not limited to:

- developing guidelines and best practices for energy conservation in buildings and physical infrastructure.
- developing guidelines and best practices for waste recycling in buildings and physical infrastructure.

### 5.4.2.2 Gap

Standards related to the low carbon design and construction in SSC are still required in the following area:

- evaluation for low carbon design and construction.

### 5.4.2.3 Relationships

ITU-T SG5 (Environment and climate change).

UNFCCC.

ISO CCCC (Climate Change Coordinating Committee).

ISO/TC 207 (Environmental management).

ISO/TC 205 (Building environment design).

ISO/TC 59 (Buildings and civil engineering works).

## 5.4.3 Intelligent building systems

### 5.4.3.1 Task

The standardization of the following technologies should be implemented in the intelligent building systems of SSC:

- synergy of intelligent building systems with related ICT systems in SSC.
- The tasks include, but are not limited to:
- developing Recommendations regarding the interface of intelligent building systems with related ICT systems in SSC.
- developing guidelines and best practices for the ICT use for intelligent building systems in SSC.

### 5.4.3.2 Gap

Standards related to the intelligent building system in SSC are still required in the following areas:

- extended application for intelligent building systems in SSC.



### 5.4.3.3 Relationships

ISO/TC 205/WG3 (Building environment design/Building Automation and Control System (BACS) Design).

ISO/TC (59 Buildings and civil engineering works).

### 5.4.4 Building information modelling (BIM)

#### 5.4.4.1 Task

The standardization of the following areas should be implemented in the building information modelling of SSC:

- synergy of building information modelling with related ICT systems in SSC.
- The tasks include, but are not limited to:
- developing Recommendations regarding the interface of building information modelling with related ICT systems in SSC including GIS, navigation, wireless telecommunication, etc.
- developing guidelines and best practices for the ICT use for building information modelling in SSC.

#### 5.4.4.2 Gap

Standards related to BIM in SSC are still required in the following areas:

- application of the building information modelling in SSC.
- hierarchical application for CityGML and IndoorGML<sup>3</sup> in SSC [OGC Report].
- combination of BIM with IoT, GIS, and wireless telecommunication in SSC.

#### 5.4.4.3 Relationships

ISO/TC 59 (Buildings and civil engineering works).

OGC (Open Geospatial Consortium).

### 5.4.5 Traffic systems

#### 5.4.5.1 Task

The tasks include, but are not limited to:

- developing guidelines for building intelligent transport system in SSC.
- developing Recommendations and best practices related to the implementation of intelligent transport system with a view to addressing environmental challenges.
- providing the necessary collaboration for joint activities in this field between ITU-T and SDOs conducting related work on ITS.

#### 5.4.5.2 Gap

Standards related to city traffic systems are still required in the following areas:

- application of the road traffic facilities in SSC.
- issues related to standards for communications required for ITS applications.

---

<sup>3</sup> See OGC report, OGC Smart Cities Spatial Information Framework.

### 5.4.5.3 Relationships

ITU-T FG CarCom (Focus Group on From/In/To Cars Communication).

ITU-T CITS (Collaboration on ITS Communication Standards).

ITU-T Q12/SG13 (Distributed service networking).

ITU-T Q27/16 (Vehicle gateway platform for telecommunication/ITS services /applications).

ISO/TC 241 (Road traffic safety management systems).

ISO/TC 204 (Intelligent transport systems).

### 5.4.6 Urban pipeline network

#### 5.4.6.1 Task

The standardization of the following technologies should be implemented in the urban pipeline of SSC:

- urban pipeline informatization;
- city geo-information infrastructure.

NOTE 1 – Urban pipelines are usually considered as the lifeline of cities for piped water, sewage, drainage, sanitation, electricity, heating, telecommunications, gas and waste, etc.

The tasks include, but are not limited to:

- developing guidelines and best practices for the urban pipeline informatization in SSC.
- developing Recommendations for the integrated management of pipeline networks including:
  - terms and definitions;
  - characteristics, high-level requirements and general capabilities;
  - information model from spatio-temporal perspective;
  - architecture framework and technical requirements.

NOTE 2 – There are several technical reports on infrastructure, integrated management, and smart water management in FG SSC [ITU-T TR infrastructure] [ITU-T TR management] [ITU-T TR water].

#### 5.4.6.2 Gap

Standards related to the urban pipeline in SSC are still required in the following areas:

- terms and definitions;
- characteristics, high-level requirements and general capabilities;
- information model from spatio-temporal perspective;
- architecture framework and technical requirements.

#### 5.4.6.3 Relationships

ISO/TMB SAG SCities (Strategic Advisory Group on Smart Cities).

IEC/SMB SEG 1 (Systems Evaluation Group - Smart Cities).

ISO/TC 268 (Sustainable development in communities).

ISO/IEC JTC 1 (Information Technology)

ISO/TC 153 (Valves).

ISO/TC 138 (Plastics pipes, fittings and valves for the transport of fluids).

ISO/TC 131 (Fluid power systems).

ISO/TC 115 (Pumps).

ISO/TC 30 (Measurement of fluid flow in closed conduits).

ISO/TC 5 (Ferrous metal pipes and metallic fittings).

## Abbreviations

This Technical Report uses the following abbreviations:

3D	Three Dimensional
3GPP	3rd Generation Partnership Project
3GPP2	3rd Generation Partnership Project 2
4G	Fourth Generation
6LoWPAN	IPv6 over Low power Wireless Personal Area Networks
AIM	Association for Automatic Identification and Mobility
ASCE	American Society of Civil Engineers
BIM	Building Information Modelling
CDMA	Code Division Multiple Access
CEN	Comité Européen de Normalisation
CENELEC	Comité Européen de Normalisation Electrotechnique
CITS	Collaboration on ITS Communication Standards
DMTF	Distributed Management Task Force
DSL	Digital Subscriber Line
DWDM	Dense Wavelength Division Multiplexing
EMF	Electromagnetic Field
EPC	Electronic Product Code
EPON	Ethernet Passive Optical Network
ETSI	European Telecommunications Standards Institute
FDD	Frequency Division Duplex
FTTx	Fibre to the x (B – Building, Business; H- Home; C – Cabinet, Curb)
GHG	Green House Gas
GIS	Geographic Information System
GML	Geography Markup Language
GPON	Gigabit Passive Optical Network
GPS	Global Positioning System
GS1	Globe Standard 1
GSM	Global System for mobile Communications
HL7	Healthcare Level 7
IETF	Internet Engineering Task Force
ICT	Information and Communication Technology
IT	Information Technology

IEC	International Electrotechnical Commission
IEEE	Institute of Electrical and Electronics Engineers
IoT	Internet of Things
ISO	International Organization for Standardization
ITS	Intelligent Transport System
ITU	International Telecommunication Union
ITU-T	International Telecommunication Union Standardization Sector
JTC	Joint Technical Committee
LTE	Long Term Evolution
M2M	Machine-to-Machine
OGC	Open Geospatial Consortium
OTN	Optical Transport Network
PC	Project Committee
PEV	Plug-in Electric Vehicle
PLC	Power Line Communication
RFID	Radio Frequency Identification
SAC	Standardization Administration of the People's Republic of China
SAG	Strategic Advisory Group
SC	Subcommittee
SDH	Synchronous Digital Hierarchy
SDO	Standards Developing Organization
SEG	Systems Evaluation Group
SG	Study Group
SIGGRAPH	Special Interest Group for Computer GRAPHICS
SMB	Standardization Management Board
SOA	Service Oriented Architecture
SSC	Smart Sustainable Cities
SWM	Smart Water Management
TC	Technical Committee
TDD	Time Division Duplex
TMB	Technical Management Board
UNFCCC	United Nations Framework Convention on Climate Change
V2I	Vehicle to Infrastructure
V2V	Vehicle to Vehicle

V2X	Vehicle to Everything
W3C	World Wide Web Consortium
WCDMA	Wideband Code Division Multiple Access
WG	Working Group
WHO	World Health Organization
WP	Working Party
xDSL	x Digital Subscriber Line



## Bibliography

[b-FG-SSC building]	FG-SSC deliverable, <i>Technical Report on smart sustainable buildings for smart sustainable cities.</i>
[b-FG-SSC stakeholders]	FG-SSC deliverable, <i>Technical Report on engaging stakeholders for smart sustainable cities.</i>
[ITU-T TR SSC Def]	<i>Technical Report on smart sustainable cities: an analysis of definitions (2014).</i>
[ITU-T TR overview]	<i>Technical Report on an overview of smart sustainable cities and the role of information and communication technologies (2014).</i>
[ITU-T TR water]	<i>Technical Report on smart water management in cities (2014).</i>
[ITU-T TR EMF Con]	<i>Technical Report on electromagnetic field (EMF) consideration in smart sustainable cities (2014).</i>
[ITU-T L.KPIs-overview]	<i>Technical Specifications on overview of key performance indicators in smart sustainable cities (2014).</i>
[ITU-T L.KPIs-ICT]	<i>Technical Specifications on key performance indicators related to the use of information and communication technology in smart sustainable cities.</i>
[ITU-T L.KPIs-impact]	<i>Technical Specifications on key performance indicators related to the sustainability impacts of information and communication technology in smart sustainable cities.</i>
[ITU-T L.KPIs-Supp]	<i>Technical Report on key performance indicators definitions for smart sustainable cities.</i>
[ITU-T TR standard]	<i>Technical Report on standardization activities for smart sustainable cities.</i>
[ITU-T TR management]	<i>Technical Report on integrated management for smart sustainable cities.</i>
[ITU-T TR infrastructure]	<i>Technical Report on overview of smart sustainable cities infrastructure.</i>
[ITU-T TR climate]	<i>Technical Report on information and communication technologies for climate change adaptation in cities.</i>
[ITU-T TR security]	<i>Technical Report on cyber-security, data protection and cyber-resilience in smart sustainable cities.</i>
[ITU-T TR leaders]	<i>Technical Report on The city we want: a guide for city leaders.</i>
[ISO Focus+]	ISO Focus + (2014), <i>Smart Cities.</i>
[ISO/IEC JTC1 SG1 Report]	<i>Report on standardization needs for Smart Cities.</i>
[OGC Report]	<i>Open Geospatial Consortium Report (2015), OGC Smart Cities Spatial Information Framework.</i>

- [SSCC-CG Report] CEN/CENELEC/ETSI SSCC-CG, *Final report and recommendations of SSCC-CG*.
- [IEEE 802.3] IEEE 802.3-2012, *IEEE Standard for Ethernet*.
- [IEEE 802.15.4] IEEE 802.15.4-2011, *IEEE Standard for Local and metropolitan area networks – Part 15.4: Low-Rate Wireless Personal Area Networks (LR-WPANs)*.
- [IEEE 1451.0] IEEE 1451.0-2007, *IEEE Standard for a Smart Transducer Interface for Sensors and Actuators –Common Functions, Communication Protocols, and Transducer Electronic Data Sheet (TEDS) Formats*.
- [IETF RFC 4919] IETF RFC 4919-2007, *IPv6 over Low-Power Wireless Personal Area Networks (6LoWPANs): Overview, Assumptions, Problem Statement, and Goals*.

Quality  
management

Standard

Customer

Certification

Process

in



Org

# ITU-T Standards

Rec

Continual  
Improvement

## 5.2

**Standardization  
activities for smart  
sustainable cities**

**Technical Report**

## Acknowledgements

This Technical Report was researched and written by Ziqin Sang (Fiberhome Technologies Group), Zhen Luo (Fiberhome Technologies Group) and Michael Mulquin (IS Communications Ltd) as a contribution to ITU-T Focus Group on Smart Sustainable Cities (FG-SSC).

The authors wish to extend their gratitude to Flavio Cucchiatti (Telecom Italia), Jinghua Min (China Electronic Cyberspace Great Wall Co., Ltd), Francesco Dadaglio (International Organization for Standardization), Fryderyk Lewicki (Orange Polska) and Paolo Gemma (Huawei) for their valuable inputs and support.

The authors acknowledge the guidance and support from all the members of the ITU-T Focus Group on Smart Sustainable Cities (FG-SSC) Management Team.

Additional information and materials relating to this report can be found at: [www.itu.int/itu-t/climatechange](http://www.itu.int/itu-t/climatechange). If you would like to provide any additional information, please contact Cristina Bueti at [tsbsg5@itu.int](mailto:tsbsg5@itu.int).

**Table of Contents**

	<b>Page</b>
<b>1</b> <b>Scope</b> .....	<b>962</b>
<b>2</b> <b>Definitions</b> .....	<b>962</b>
2.1 Terms defined elsewhere.....	962
<b>3</b> <b>Standards related to key SSC issues</b> .....	<b>963</b>
3.1 SSC terminology standards .....	963
3.2 SSC services standards .....	963
3.3 Information and communication technology standards .....	1025
3.4 SSC management and assessment standards.....	1053
3.5 Building and physical infrastructure standards .....	1056
<b>4</b> <b>Relevant SDOs and their work on SSC</b> .....	<b>1063</b>
<b>5</b> <b>Other organizations and their work on SSC</b> .....	<b>1091</b>
<b>Abbreviations</b> .....	<b>1099</b>
<b>Bibliography</b> .....	<b>1101</b>





## Standardization activities for smart sustainable cities

### Executive summary

This Technical Report is a deliverable of the ITU-T Focus Group on Smart Sustainable Cities (FG-SSC), and is one of two Technical Reports on standardization activities, gap analysis, roadmap and suggestions to ITU study groups for smart sustainable cities (SSC).

This Technical Report uses the framework of standards proposed in the “Technical Report on standardization roadmap for smart sustainable cities”, identifies the SSC-related activities of standardization development organizations (SDOs), consortium and forums, and lists available SSC-related standards. It also summarizes relevant organizations and their work on SSC.

This Technical Report is structured around four main sections. Section one presents the scope of the report. Section five collects standards related to key SSC issues. Section six briefly summarizes SSC related SDOs, and section seven gives the information of other organizations and their work on SSC.

## 1 Scope

---

This Technical Report provides the SSC-related activities currently undertaken by the various standards developing organizations (SDOs), consortium and forums. It also provides lists of relevant standards published in the past.

The main objective is to provide suggestions for potential standardization activities to ITU-T Study Group 5 (SG5). It is hoped that it could also provide the basis for a wider standardization roadmap involving other ITU groups and other SDOs.

## 2 Definitions

---

### 2.1 Terms defined elsewhere

This Technical Report uses the following terms defined elsewhere:

**2.1.1 city** [ITU-T L.KPIs-overview]: An urban geographical area with one (or several) local government and planning authorities.

**2.1.2 smart sustainable cities** [ITU-T TR SSC Def]: A smart sustainable city is an innovative city that uses information and communication technologies (ICTs) and other means to improve quality of life, efficiency of urban operation and services, and competitiveness, while ensuring that it meets the needs of present and future generations with respect to economic, social, environmental as well as cultural aspects.

## 3 Standards related to key SSC issues<sup>1</sup>

### 3.1 SSC terminology standards

It is essential to have a holistic vocabulary for the initiatives on smart sustainable cities. FG-SSC now has reached agreement on the definition of SSC. However, more efforts are needed to standardize the terms and definitions covering all the aspects of SSC.

Work area	FG-SSC deliverable(s) related to this work area	SDO working on this area	Document number released by this SDO	Corresponding document title	Standardization gap in this area	Future needs and suggestions to SG5
Terms and definitions	Agreed definition of SSC [ITU-T TR SSC Def]	None	None	None	Need more terms and definitions covering all aspects of SSC	To develop standards on terms and definitions

### 3.2 SSC services standards

#### 3.2.1 E-Government

The services and applications of e-government include but are not limited to:

- information sharing
- electronic document streaming
- data directory service
- data exchange service including:
  - (a) office automation
  - (b) real-time information releasing
  - (c) Transparency around governmental decision-making and open data
  - (d) electronic public-opinion polling

FG-SSC has released a Technical Report on integrated management for SSC [ITU-T TR management] which explains the services and applications of e-government in SSC.

ISO/IEC has some fundamental standards about information technologies, including vocabulary, metadata registries, software product evaluation, security techniques-evaluation criteria for IT security, open systems interconnection-security frameworks for open systems, security techniques-digital signatures with appendix, security techniques-entity authentication, security techniques-non-repudiation, open systems interconnection-systems management. However, the standards specific to the above services and applications of e-government are still not available.

It is suggested to develop guidelines for the services and applications of e-government for SSC at first, then consider the development of a series of standards including the terms and definitions, service model, information management, and security etc.

<sup>1</sup> This Technical Report adopts the classification of standards proposed in [ITU-T TR roadmap].



Work area	FG-SSC deliverable(s) related to this work area	SDO working on this area	Document number released by this SDO	Corresponding document title	Standardization gap in this area	Future needs and suggestions to SG5
E-Government	Integrated management for SSC [ITU-T TR management]	ISO/IEC	ISO/IEC 2382	Information technology – Vocabulary – Part 1: Fundamental terms; Part 4: Organization of data; Part 5: Representation of data; Part 7: Computer programming; Part 8: Security; Part 9: Data communication; Part 13: Computer graphics; Part 14: Reliability, maintainability and availability; Part 15: Programming languages; Part 16: Information theory; Part 17: Databases; Part 18: Distributed data processing; Part 20: System development; Part 23: Text processing; Part 24: Computer-integrated manufacturing; Part 25: Local area networks; Part 26: Open systems interconnection; Part 27: Office automation; Part 28: Artificial intelligence – Basic concepts and expert systems; Part 29: Artificial intelligence-Speech recognition and synthesis; Part 31: Artificial intelligence – Machine learning; Part 32: Electronic Mail; Part 34: Artificial intelligence-Neural networks; Part 36: Learning, education and training	Need to select the necessary vocabularies	To develop guidelines for the services and applications of e-government in SSC
			ISO/IEC 11179	Information technology – Metadata registries (MDR) – Part 1: Framework; Part 2: Classification; Part 3: Registry metamodel and basic attributes; Part 4: Formulation of data definitions; Part 5: Naming and identification principles; Part 6: Registration	Can be referenced for developing service model of e-government	To develop a service model of e-government for SSC
			ISO/IEC 14598	Information technology – Software product evaluation – Part 1: General overview; Part 2: Planning and management; Part 3: Process for developers; Part 4: Process for acquirers; Part 5: Process for evaluators	Can be referenced for developing service model of e-government	

Work area	FG-SSC deliverable(s) related to this work area	SDO working on this area	Document number released by this SDO	Corresponding document title	Standardization gap in this area	Future needs and suggestions to SG5
			ISO/IEC 15408	Information technology – Security techniques – Evaluation criteria for IT security-Part 1: Introduction and general model; Part 2: Security functional requirements; Part 3: Security assurance components	Can be referenced for developing service model of e-government	To develop a service model of e-government, and security will be considered
			ISO/IEC 10164	Information technology – Open Systems Interconnection – Systems Management: Object Management Function; State Management Function; Attributes for representing relationships; Alarm reporting function; Event Report Management Function; Log control function; Security alarm reporting function; Security audit trail function; Objects and attributes for access control; Usage metering function for accounting purposes; Metric objects and attributes; Test Management Function; Summarization Function; Confidence and diagnostic test categories; Scheduling function; Management knowledge management function; Change over function; Software management function; Management domain and management policy management function; Time management function; Command sequencer for Systems Management; Response time monitoring function	Can be referenced for developing information management of e-government	To develop information management of e-government for SSC

### 3.2.2 Transport

The services and applications of city transport system include but are not limited to:

- Traffic information service
- Traffic telematics
- Information exchange between V2V, V2I, and V2X
- Traffic emergency processing

There is a Technical Report on ICT infrastructure for SSC which involves facilities of IoT in FG-SSC [b-FG-SSC infrastructure]. There are several TCs working on traffic/transport standardization in ISO, ETSI, SAE, IEEE, IETF, etc.

It is suggested to develop a guideline for applications on Intelligent Transport Systems (ITS) in SSC at first.



Work area	FG-SSC deliverable(s) related to this work area	SDO working on this area	Document number released by this SDO	Corresponding document title	Standardization gap in this area	Future needs and suggestions to SG5
Traffic telematics		CITS (Collaboration on ITS Communication Standards)	ITU-T HSTP-CITS-Reqs	Global ITS Communication Requirements (Version 1)	Overview of telecommunication/ITS, use case on ITS in SSC applications	To develop a guideline for applications on ITS in SSC
		ITU-T FG CarCom (Focus Group on From/In/To Cars Communication)		ITU Focus Group on Car Communication-Final Report ( <a href="http://www.itu.int/en/ITU-T/focusgroups/carcom/Documents/Technical_report.pdf">http://www.itu.int/en/ITU-T/focusgroups/carcom/Documents/Technical_report.pdf</a> )		
		ITU-T Q4/SG12 (Hands-free communication and user interfaces in vehicles)	ITU-T P.1100	Narrowband hands-free communication in motor vehicles		
			ITU-T P.1110	Wideband hands-free communication in motor vehicles		
		ITU-T FG Distraction (Focus Group on Driver Distraction)		FG Distraction report on Situational Awareness Management		
		ITU-T Q27/16 (Vehicle gateway platform for telecommunication/ITS services/applications)				

Work area	FG-SSC deliverable(s) related to this work area	SDO working on this area	Document number released by this SDO	Corresponding document title	Standardization gap in this area	Future needs and suggestions to SG5
Vehicle charging and communication		CITS (Collaboration on ITS Communication Standards)	ITU-T HSTP-CITS-Reqs	Global ITS Communication Requirements (Version 1)		
		ITU-T Q15/SG15 (Communications for Smart Grid)	ITU-T G.9901	Narrow-band orthogonal frequency division multiplexing power line communication transceivers - power spectral density specification		
			ITU-T G.9902	Narrow-band orthogonal frequency division multiplexing power line communication transceivers for ITU-T G.hnem networks		
			ITU-T G.9903	Narrow-band orthogonal frequency division multiplexing power line communication transceivers for G3-PLC networks		
			ITU-T G.9904	Narrow-band OFDM power line communication transceivers – PRIME		
Information exchange between V2V, V2I, and V2X		CITS (Collaboration on ITS Communication Standards)	ITU-T HSTP-CITS-Reqs	Global ITS Communication Requirements (Version 1)		

Work area	FG-SSC deliverable(s) related to this work area	SDO working on this area	Document number released by this SDO	Corresponding document title	Standardization gap in this area	Future needs and suggestions to SG5
		ITU-T Q27/16 (Vehicle gateway platform for tele-communication/ITS services/applications)		Communications interface between external applications and a Vehicle Gateway Platform Service and functional requirements of vehicle gateway platforms Functional architecture model of vehicle gateways Architecture and functional entities of vehicle gateway platforms		
		ITU-T Q12/SG13 (Distributed service networking)	ITU-T Y.2281	Framework of networked vehicle services and applications using NGN		
Road traffic safety management systems	SSC infrastructure [b-FG-SSC infrastructure]	ISO/TC 241 (Road traffic safety management systems)	ISO 39001:2012	Road traffic safety (RTS) management systems – Requirements with guidance for use	Can be referenced for developing service model of ITS for SSC	To develop standards for guidelines and best practices related to the services and functional requirements of the traffic emergency processing for SSC
		ITU-T Q4/SG12 (Hands-free communication and user interfaces in vehicles)	ITU-T P.emergency	Speech Quality Requirements for Emergency Calls		
Intelligent transport systems	SSC infrastructure [b-FG-SSC infrastructure]	CITS (Collaboration on ITS Communication Standards)	ITU-T HSTP-CITS-Req	Global ITS Communication Requirements (Version 1)		To develop standards for guidelines and best practices related to the services and functional requirements of the traffic emergency processing for SSC

Work area	FG-SSC deliverable(s) related to this work area	SDO working on this area	Document number released by this SDO	Corresponding document title	Standardization gap in this area	Future needs and suggestions to SG5
		ISO/TC 204 (Intelligent transport systems) (**)	ISO 10711:2012	Intelligent Transport Systems – Interface Protocol and Message Set Definition between Traffic Signal Controllers and Detectors		
			ISO/TR 10992:2011	Intelligent transport systems – Use of nomadic and portable devices to support ITS service and multimedia provision in vehicles		
			ISO 11067	Intelligent transport systems – Curve speed warning systems (CSWS) – Performance requirements and test procedures		
			ISO 11270:2014	Intelligent transport systems – Lane keeping assistance systems (LKAS) – Performance requirements and test procedures		
			ISO/TR 11766:2010	Intelligent transport systems – Communications access for land mobiles (CALM) – Security considerations for lawful interception		
			ISO/TR 11769:2010	Intelligent transport systems – Communications access for land mobiles (CALM) – Data retention for law enforcement		
			ISO/TS 12813:2009	Electronic fee collection – Compliance check communication for Autonomous systems		
			ISO 12855:2012	Electronic fee collection – Information exchange between service provision and toll charging		
			ISO/TR 12859:2009	Intelligent transport systems – System architecture – Privacy aspects in ITS standards and systems		
			ISO/TS 13140-1:2011	Electronic fee collection – Evaluation of on-board and roadside equipment for conformity to ISO/TS 13141 – Part 1: Test suite structure and test purposes		

Work area	FG-SSC deliverable(s) related to this work area	SDO working on this area	Document number released by this SDO	Corresponding document title	Standardization gap in this area	Future needs and suggestions to SG5
			ISO/TS 13140-2:2012	Electronic fee collection – Evaluation of on-board and roadside equipment for conformity to ISO/TS 13141 – Part 2: Abstract test suite		
			ISO/TS 13141:2010	Electronic fee collection – Localisation augmentation communication for autonomous systems		
			ISO/TS 13143-1:2011	Electronic fee collection – Evaluation of on-board and roadside equipment for conformity to ISO/TS 12813 – Part 1: Test suite structure and test purposes		
			ISO/TS 13143-2:2011	Electronic fee collection – Evaluation of on-board and roadside equipment for conformity to ISO/TS 12813 – Part 2: Abstract test suite		
			ISO 13183:2012	Intelligent transport systems – Communications access for land mobiles (CALM) – Using broadcast communications		
			ISO/TR 13184-1:2013	Intelligent transport systems – Guidance protocol via personal ITS station for advisory safety systems – Part 1: General information and use case definitions		
			ISO/TR 13185-1:2012	Intelligent transport systems – Vehicle interface for provisioning and support of ITS services – Part 1: General information and use case definition		
			ISO/TR 14806:2013	Intelligent transport systems – Public transport requirements for the use of payment applications for fare media		
			ISO 14813-1:2007	Intelligent transport systems – Reference model architecture(s) for the ITS sector – Part 1: ITS service domains, service groups and services		

Work area	FG-SSC deliverable(s) related to this work area	SDO working on this area	Document number released by this SDO	Corresponding document title	Standardization gap in this area	Future needs and suggestions to SG5
			ISO 14813-5:2010	Intelligent transport systems – Reference model architecture(s) for the ITS sector – Part 5: Requirements for architecture description in ITS standards		
			ISO 14813-6:2009	Intelligent transport systems – Reference model architecture(s) for the ITS sector – Part 6: Data presentation in ASN.1		
			ISO 14814:2006	Road transport and traffic telematics – Automatic vehicle and equipment identification – Reference architecture and terminology		
			ISO 14815:2005	Road transport and traffic telematics – Automatic vehicle and equipment identification – System specifications		
			ISO 14816:2005	Road transport and traffic telematics – Automatic vehicle and equipment identification – Numbering and data structure		
			ISO 14817:2002	Transport information and control systems – Requirements for an ITS/TICS central Data Registry and ITS/TICS Data Dictionaries		
			ISO 14819-1:2013	Intelligent transport systems – Traffic and travel information messages via traffic message coding – Part 1: Coding protocol for Radio Data System – Traffic Message Channel (RDS-TMC) using ALERT-C		
			ISO 14819-2:2013	Intelligent transport systems – Traffic and travel information messages via traffic message coding – Part 2: Event and information codes for Radio Data System – Traffic Message Channel (RDS-TMC) using ALERT-C		



Work area	FG-SSC deliverable(s) related to this work area	SDO working on this area	Document number released by this SDO	Corresponding document title	Standardization gap in this area	Future needs and suggestions to SG5
			ISO 14819-3:2013	Intelligent transport systems – Traffic and travel information messages via traffic message coding – Part 3: Location referencing for Radio Data System – Traffic Message Channel (RDS-TMC) using ALERT-C		
			ISO 14819-6:2006	Traffic and Traveller Information (TTI) – TTI messages via traffic message coding – Part 6: Encryption and conditional access for the Radio Data System – Traffic Message Channel ALERT C coding		
			ISO/TS 14823:2008	Traffic and travel information – Messages via media independent stationary dissemination systems – Graphic data dictionary for pre-trip and in-trip information dissemination systems		
			ISO 14825:2011	Intelligent transport systems – Geographic Data Files (GDF) – GDF5.0		
			ISO 14827-1:2005	Transport information and control systems – Data interfaces between centres for transport information and control systems – Part 1: Message definition requirements		
			ISO 14827-2:2005	Transport information and control systems – Data interfaces between centres for transport information and control systems – Part 2: DATEX-ASN		
			ISO/TS 14904:2002	Road transport and traffic telematics – Electronic fee collection (EFC) – Interface specification for clearing between operators		
			ISO 14906:2011	Electronic fee collection – Application interface definition for dedicated short-range communication		

Work area	FG-SSC deliverable(s) related to this work area	SDO working on this area	Document number released by this SDO	Corresponding document title	Standardization gap in this area	Future needs and suggestions to SG5
			ISO/TS 14907-1:2010	Electronic fee collection – Test procedures for user and fixed equipment – Part 1: Description of test procedures		
			ISO/TS 14907-2:2011	Electronic fee collection – Test procedures for user and fixed equipment – Part 2: Conformance test for the onboard unit application interface		
			ISO 15075:2003	Transport information and control systems – In-vehicle navigation systems – Communications message set requirements		
			ISO 15622:2010	Intelligent transport systems – Adaptive Cruise Control systems – Performance requirements and test procedures		
			ISO 15623:2013	Intelligent transport systems – Forward vehicle collision warning systems – Performance requirements and test procedures		
			ISO/TS 15624:2001	Transport information and control systems – Traffic Impediment Warning Systems (TIWS) – System requirements		
			ISO 15628:2013	Intelligent transport systems – Dedicated short range communication (DSRC) – DSRC application layer		
			ISO 15638-1:2012	Intelligent transport systems – Framework for collaborative Telematics Applications for Regulated commercial freight Vehicles (TARV) – Part 1: Framework and architecture		
			ISO 15638-2:2013	Intelligent transport systems – Framework for collaborative Telematics Applications for Regulated commercial freight Vehicles (TARV) – Part 2: Common platform parameters using CALM		

Work area	FG-SSC deliverable(s) related to this work area	SDO working on this area	Document number released by this SDO	Corresponding document title	Standardization gap in this area	Future needs and suggestions to SG5
			ISO 15638-3:2013	Intelligent transport systems – Framework for collaborative telematics applications for regulated commercial freight vehicles (TARV) – Part 3: Operating requirements, 'Approval Authority' procedures, and enforcement provisions for the providers of regulated services		
			ISO 15638-5:2013	Intelligent transport systems – Framework for collaborative Telematics Applications for Regulated commercial freight Vehicles (TARV) – Part 5: Generic vehicle information		
			ISO 15638-6:2014	Intelligent transport systems – Framework for collaborative Telematics Applications for Regulated commercial freight Vehicles (TARV) – Part 6: Regulated applications		
			ISO 15638-7:2013	Intelligent transport systems – Framework for collaborative Telematics Applications for Regulated commercial freight Vehicles (TARV) – Part 7: Other applications		
			ISO 15638-8:2014	Intelligent transport systems – Framework for cooperative telematics applications for regulated vehicles (TARV) – Part 8: Vehicle access management		
			ISO/TS 15638-9:2013	Intelligent transport systems – Framework for collaborative Telematics Applications for Regulated commercial freight Vehicles (TARV) – Part 9: Remote electronic tachograph monitoring (RTM)		
			ISO/TS 15638-10:2013	Intelligent transport systems – Framework for collaborative Telematics Applications for Regulated commercial freight Vehicles (TARV) – Part 10: Emergency messaging system/eCall (EMS)		

Work area	FG-SSC deliverable(s) related to this work area	SDO working on this area	Document number released by this SDO	Corresponding document title	Standardization gap in this area	Future needs and suggestions to SG5
			ISO 15638-11:2014	Intelligent transport systems – Framework for cooperative telematics applications for regulated vehicles (TARV) – Part 11: Driver work records		
			ISO 15638-12:2014	Intelligent transport systems – Framework for cooperative telematics applications for regulated vehicles (TARV) – Part 12: Vehicle mass monitoring		
			ISO 15638-14:2014	Intelligent transport systems – Framework for cooperative telematics applications for regulated vehicles (TARV) – Part 14: Vehicle access control		
			ISO 15638-15:2014	Intelligent transport systems – Framework for cooperative telematics applications for regulated vehicles (TARV) – Part 15: Vehicle location monitoring		
			ISO 15638-16:2014	Intelligent transport systems – Framework for cooperative telematics applications for regulated vehicles (TARV) – Part 16: Vehicle speed monitoring		
			ISO 15638-17:2014	Intelligent transport systems – Framework for cooperative telematics applications for regulated vehicles (TARV) – Part 17: Consignment and location monitoring		
			ISO/TS 15638-18:2013	Intelligent transport systems – Framework for collaborative Telematics Applications for Regulated commercial freight Vehicles (TARV) – Part 18: ADR (Dangerous Goods) transport monitoring (ADR)		

Work area	FG-SSC deliverable(s) related to this work area	SDO working on this area	Document number released by this SDO	Corresponding document title	Standardization gap in this area	Future needs and suggestions to SG5
			ISO/TS 15638-19:2013	Intelligent transport systems – Framework for collaborative Telematics Applications for Regulated commercial freight Vehicles (TARV) – Part 19: Vehicle parking facilities (VPF)		
			ISO 15662:2006	Intelligent transport systems – Wide area communication – Protocol management information		
			ISO 15784-1:2008	Intelligent transport systems (ITS) – Data exchange involving roadside modules communication – Part 1: General principles and documentation framework of application profiles		
			ISO 15784-3:2008	Intelligent transport systems (ITS) – Data exchange involving roadside modules communication – Part 3: Application profile-data exchange (AP-DATEX)		
			ISO/TS 16401-1:2012	Electronic fee collection – Evaluation of equipment for conformity to ISO/TS 17575-2 – Part 1: Test suite structure and test purposes		
			ISO/TS 16401-2:2012	Electronic fee collection – Evaluation of equipment for conformity to ISO/TS 17575-2 – Part 2: Abstract test suite		
			ISO/TS 16403-1:2012	Electronic fee collection – Evaluation of equipment for conformity to ISO/TS 17575-4 – Part 1: Test suite structure and test purposes		
			ISO/TS 16403-2:2012	Electronic fee collection – Evaluation of equipment for conformity to ISO/TS 17575-4 – Part 2: Abstract test suite		
			ISO/TS 16407-1:2011	Electronic fee collection – Evaluation of equipment for conformity to ISO/TS 17575-1 – Part 1: Test suite structure and test purposes		

Work area	FG-SSC deliverable(s) related to this work area	SDO working on this area	Document number released by this SDO	Corresponding document title	Standardization gap in this area	Future needs and suggestions to SG5
			ISO/TS 16407-2:2012	Electronic fee collection – Evaluation of equipment for conformity to ISO/TS 17575-1 – Part 2: Abstract test suite		
			ISO/TS 16410-1:2011	Electronic fee collection – Evaluation of equipment for conformity to ISO/TS 17575-3 – Part 1: Test suite structure and test purposes		
			ISO/TS 16410-2:2012	Electronic fee collection – Evaluation of equipment for conformity to ISO/TS 17575-3 – Part 2: Abstract test suite		
			ISO/TS 16785:2014	Electronic Fee Collection (EFC) – Interface definition between DSRC-OBE and external in-vehicle devices		
			ISO 17185-1:2014	Intelligent transport systems – Public transport user information – Part 1: Standards framework for public information systems		
			ISO/TS 17187:2013	Intelligent transport systems – Electronic information exchange to facilitate the movement of freight and its intermodal transfer – Governance rules to sustain electronic information exchange methods		
			ISO 17261:2012	Intelligent transport systems – Automatic vehicle and equipment identification – Intermodal goods transport architecture and terminology		
			ISO 17262:2012	Intelligent transport systems – Automatic vehicle and equipment identification – Numbering and data structures		
			ISO 17263:2012	Intelligent transport systems – Automatic vehicle and equipment identification – System parameters		



Work area	FG-SSC deliverable(s) related to this work area	SDO working on this area	Document number released by this SDO	Corresponding document title	Standardization gap in this area	Future needs and suggestions to SG5
			ISO 17264:2009	Intelligent transport systems – Automatic vehicle and equipment identification – Interfaces		
			ISO 17267:2009	Intelligent transport systems – Navigation systems – Application programming interface (API)		
			ISO 17361:2007	Intelligent transport systems – Lane departure warning systems – Performance requirements and test procedures		
			ISO/TR 17384:2008	Intelligent transport systems – Interactive centrally determined route guidance (CDRG) – Air interface message set, contents and format		
			ISO 17386:2010	Transport information and control systems – Manoeuvring Aids for Low Speed Operation (MALSO) – Performance requirements and test – procedures		
			ISO 17387:2008	Intelligent transport systems – Lane change decision aid systems (LCDAS) – Performance requirements and test procedures		
			ISO/TS 17419:2014	Intelligent transport systems – Cooperative systems – Classification and management of ITS applications in a global context		
			ISO/TS 17423:2014	Intelligent transport systems – Cooperative systems – ITS application requirements and objectives for selection of communication profiles		

Work area	FG-SSC deliverable(s) related to this work area	SDO working on this area	Document number released by this SDO	Corresponding document title	Standardization gap in this area	Future needs and suggestions to SG5
			ISO/TS 17427:2014	Intelligent transport systems – Cooperative systems – Roles and responsibilities in the context of cooperative ITS based on architecture(s) for cooperative systems		
			ISO/TS 17444-1:2012	Electronic fee collection – Charging performance – Part 1: Metrics		
			ISO/TS 17444-2:2013	Electronic fee collection – Charging performance – Part 2: Examination Framework		
			ISO/TR 17452:2007	Intelligent transport systems – Using UML for defining and documenting ITS/TICS interfaces		
			ISO/TR 17465-1:2014	Intelligent transport systems – Cooperative ITS – Part 1: Terms and definitions		
			ISO 17572-1:2015	Intelligent transport systems (ITS) – Location referencing for geographic databases – Part 1: General requirements and conceptual model		
			ISO 17572-2:2015	Intelligent transport systems (ITS) – Location referencing for geographic databases – Part 2: Pre-coded location references (pre-coded profile)		
			ISO 17572-3:2015	Intelligent transport systems (ITS) – Location referencing for geographic databases – Part 3: Dynamic location references (dynamic profile)		
			ISO 17573:2010	Electronic fee collection – Systems architecture for vehicle-related tolling		
			ISO/TS 17574:2009	Electronic fee collection - Guidelines for security protection profiles		

Work area	FG-SSC deliverable(s) related to this work area	SDO working on this area	Document number released by this SDO	Corresponding document title	Standardization gap in this area	Future needs and suggestions to SG5
			ISO/TS 17575-1:2010	Electronic fee collection – Application interface definition for autonomous systems – Part 1: Charging		
			ISO/TS 17575-2:2010	Electronic fee collection – Application interface definition for autonomous systems – Part 2: Communication and connection to the lower layers		
			ISO/TS 17575-3:2011	Electronic fee collection – Application interface definition for autonomous systems – Part 3: Context data		
			ISO/TS 17575-4:2011	Electronic fee collection – Application interface definition for autonomous systems – Part 4: Roaming		
			ISO/PAS 17684:2003	Transport information and control systems – In-vehicle navigation systems – ITS message set translator to ASN.1 format definitions		
			ISO 17687:2007	Transport Information and Control Systems (TICS) – General fleet management and commercial freight operations – Data dictionary and message sets for electronic identification and monitoring of hazardous materials/ dangerous goods transportation		
			ISO/TS 17931:2013	Intelligent transport systems – Extension of map database specifications for Local Dynamic Map for applications of Cooperative ITS		
			ISO/TS 18234-1:2013	Intelligent transport systems – Traffic and travel information via transport protocol experts group, generation 1 (TPEG1) binary data format – Part 1: Introduction, numbering and versions (TPEG1-INV)		

Work area	FG-SSC deliverable(s) related to this work area	SDO working on this area	Document number released by this SDO	Corresponding document title	Standardization gap in this area	Future needs and suggestions to SG5
			ISO/TS 18234-2:2013	Intelligent transport systems – Traffic and travel information via transport protocol experts group, generation 1 (TPEG1) binary data format – Part 2: Syntax, semantics and framing structure (TPEG1-SSF)		
			ISO/TS 18234-3:2013	Intelligent transport systems – Traffic and travel information via transport protocol experts group, generation 1 (TPEG1) binary data format – Part 3: Service and network information (TPEG1-SNI)		
			ISO/TS 18234-4:2006	Traffic and Travel Information (TTI) – TTI via Transport Protocol Expert Group (TPEG) data-streams – Part 4: Road Traffic Message (RTM) application		
			ISO/TS 18234-5:2006	Traffic and Travel Information (TTI) – TTI via Transport Protocol Expert Group (TPEG) data-streams – Part 5: Public Transport Information (PTI) application		
			ISO/TS 18234-6:2006	Traffic and Travel Information (TTI) – TTI via Transport Protocol Expert Group (TPEG) data-streams – Part 6: Location referencing applications		
			ISO/TS 18234-7:2013	Intelligent transport systems – Traffic and travel information via transport protocol experts group, generation 1 (TPEG1) binary data format – Part 7: Parking information (TPEG1-PKI)		
			ISO/TS 18234-8:2012	Intelligent transport systems – Traffic and travel information via transport protocol experts group, generation 1 (TPEG1) binary data format – Part 8: Congestion and Travel Time application (TPEG1-CTT)		

Work area	FG-SSC deliverable(s) related to this work area	SDO working on this area	Document number released by this SDO	Corresponding document title	Standardization gap in this area	Future needs and suggestions to SG5
			ISO/TS 18234-9:2013	Intelligent transport systems – Traffic and travel information via transport protocol experts group, generation 1 (TPEG1) binary data format – Part 9: Traffic event compact (TPEG1-TEC)		
			ISO/TS 18234-10:2013	Intelligent transport systems – Traffic and travel information via transport protocol experts group, generation 1 (TPEG1) binary data format – Part 10: Conditional access information (TPEG1-CAI)		
			ISO/TS 18234-11:2013	Intelligent transport systems – Traffic and Travel Information (TTI) via transport protocol experts group, generation 1 (TPEG1) binary data format – Part 11: Location Referencing Container (TPEG1-LRC)		
			ISO/TS 20452:2007	Requirements and Logical Data Model for a Physical Storage Format (PSF) and an Application Program Interface (API) and Logical Data Organization for PSF used in Intelligent Transport Systems (ITS) Database Technology		
			ISO 21210:2012	Intelligent transport systems – Communications access for land mobiles (CALM) – IPv6 Networking		
			ISO 21212:2008	Intelligent transport systems – Communications access for land mobiles (CALM) – 2G Cellular systems		
			ISO 21213:2008	Intelligent transport systems – Communications access for land mobiles (CALM) – 3G Cellular systems		
			ISO 21214:2006	Intelligent transport systems – Communications access for land mobiles (CALM) – Infra-red systems		

Work area	FG-SSC deliverable(s) related to this work area	SDO working on this area	Document number released by this SDO	Corresponding document title	Standardization gap in this area	Future needs and suggestions to SG5
			ISO 21215:2010	Intelligent transport systems – Communications access for land mobiles (CALM) – M5		
			ISO 21216:2012	Intelligent transport systems – Communication access for land mobiles (CALM) – Millimetre wave air interface		
			ISO 21217:2014	Intelligent transport systems – Communications access for land mobiles (CALM) – Architecture		
			ISO 21218:2013	Intelligent transport systems – Communications access for land mobiles (CALM) – Access technology support		
			ISO/TS 21219-2:2014	Intelligent transport systems – Traffic and travel information (TTI) via transport protocol experts group, generation 2 (TPEG2) – Part 2: UML modelling rules		
			ISO/TS 21219-3:2015	Intelligent transport systems - Traffic and travel information (TTI) via transport protocol experts group, generation 2 (TPEG2) – Part 3: UML to binary conversion rules		
			ISO/TS 21219-4:2015	Intelligent transport systems – Traffic and travel information (TTI) via transport protocol experts group, generation 2 (TPEG2) – Part 4: UML to XML conversion rules		
			ISO/TS 21219-5:2015	Intelligent transport systems - Traffic and travel information (TTI) via transport protocol experts group, generation 2 (TPEG2) – Part 5: Service framework (TPEG2-SFW)		
			ISO/TS 21219-6:2015	Intelligent transport systems - Traffic and travel information via transport protocol experts group, generation 2(TPEG2) – Part 6: Message management container (TPEG2-MMC)		



Work area	FG-SSC deliverable(s) related to this work area	SDO working on this area	Document number released by this SDO	Corresponding document title	Standardization gap in this area	Future needs and suggestions to SG5
			ISO/TS 21219-18:2015	Intelligent transport systems - Traffic and travel information (TTI) via transport protocol experts group, generation 2 (TPEG2) – Part 18: Traffic flow and prediction application (TPEG2-TFP)		
			ISO/TR 21707:2008	Intelligent transport systems – Integrated transport information, management and control – Data quality in ITS systems		
			ISO 22178:2009	Intelligent transport systems – Low speed following (LSF) systems – Performance requirements and test procedures		
			ISO 22179:2009	Intelligent transport systems – Full speed range adaptive cruise control (FSRA) systems – Performance requirements and test procedures		
			ISO 22837:2009	Vehicle probe data for wide area communications		
			ISO 22839:2013	Intelligent transport systems – Forward vehicle collision mitigation systems – Operation, performance, and verification requirements		
			ISO 22840:2010	Intelligent transport systems – Devices to aid reverse manoeuvres – Extended-range backing aid systems (ERBA)		
			ISO 22951:2009	Data dictionary and message sets for preemption and prioritization signal systems for emergency and public transport vehicles (PRESTO)		
			ISO 24014-1:2007	Public transport – Interoperable fare management system – Part 1: Architecture		
			ISO/TR 24014-2:2013	Public transport – Interoperable fare management system – Part 2: Business practices		

Work area	FG-SSC deliverable(s) related to this work area	SDO working on this area	Document number released by this SDO	Corresponding document title	Standardization gap in this area	Future needs and suggestions to SG5
			ISO/TR 24014-3:2013	Public transport – Interoperable fare management system – Part 3: Complementary concepts to Part 1 for Multi-application media		
			ISO 24097-1:2009	Intelligent transport systems – Using web services (machine-machine delivery) for ITS service delivery – Part 1: Realization of interoperable web services		
			ISO/TR 24098:2007	Intelligent transport systems – System architecture, taxonomy and terminology – Procedures for developing ITS deployment plans utilizing ITS system architecture		
			ISO 24099:2011	Navigation data delivery structures and protocols		
			ISO 24100:2010	Intelligent transport systems – Basic principles for personal data protection in probe vehicle information services		
			ISO 24101-1:2008	Intelligent transport systems – Communications access for land mobiles (CALM) – Application management – Part 1: General requirements		
			ISO 24101-2:2010	Intelligent transport systems – Communications access for land mobiles (CALM) – Application management – Part 2: Conformance test		
			ISO 24102:2010	Intelligent transport systems – Communications access for land mobiles (CALM) – Management		
			ISO 24102-1:2013	Intelligent transport systems – Communications access for land mobiles (CALM) – ITS station management – Part 1: Local management		

Work area	FG-SSC deliverable(s) related to this work area	SDO working on this area	Document number released by this SDO	Corresponding document title	Standardization gap in this area	Future needs and suggestions to SG5
			ISO 24102-3:2013	Intelligent transport systems – Communications access for land mobiles (CALM) – ITS station management – Part 3: Service access points		
			ISO 24102-4:2013	Intelligent transport systems – Communications access for land mobiles (CALM) – ITS station management – Part 4: Station-internal management communications		
			ISO 24102-5:2013	Intelligent transport systems – Communications access for land mobiles (CALM) – ITS station management – Part 5: Fast service advertisement protocol (FSAP)		
			ISO 24103:2009	Intelligent transport systems – Communications access for land mobiles (CALM) – Media adapted interface layer (MAIL)		
			ISO/TR 24529:2008	Intelligent transport systems – Systems architecture – Use of unified modelling language (UML) in ITS International Standards and deliverables		
			ISO/TS 24530-1:2006	Traffic and Travel Information (TTI) – TTI via Transport Protocol Experts Group (TPEG) Extensible Markup Language (XML) – Part 1: Introduction, common data types and tpegML		
			ISO/TS 24530-2:2006	Traffic and Travel Information (TTI) – TTI via Transport Protocol Experts Group (TPEG) Extensible Markup Language (XML) – Part 2: tpeg-locML		
			ISO/TS 24530-3:2006	Traffic and Travel Information (TTI) – TTI via Transport Protocol Experts Group (TPEG) Extensible Markup Language (XML) – Part 3: tpeg-rtmML		

Work area	FG-SSC deliverable(s) related to this work area	SDO working on this area	Document number released by this SDO	Corresponding document title	Standardization gap in this area	Future needs and suggestions to SG5
			ISO/TS 24530-4:2006	Traffic and Travel Information (TTI) – TTI via Transport Protocol Experts Group (TPEG) Extensible Markup Language (XML) – Part 4: tpeg-ptiML		
			ISO 24531:2013	Intelligent transport systems – System architecture, taxonomy and terminology – Using XML in ITS standards, data registries and data dictionaries		
			SO/TR 24532:2006	Intelligent transport systems – Systems architecture, taxonomy and terminology – Using CORBA (Common Object Request Broker Architecture) in ITS standards, data registries and data dictionaries		
			ISO/TS 24533:2012	Intelligent transport systems – Electronic information exchange to facilitate the movement of freight and its intermodal transfer – Road transport information exchange methodology		
			ISO 24534-1:2010	Automatic vehicle and equipment identification – Electronic registration identification (ERI) for vehicles – Part 1: Architecture		
			ISO 24534-2:2010	Automatic vehicle and equipment identification – Electronic registration identification (ERI) for vehicles – Part 2: Operational requirements		
			ISO 24534-3:2010	Automatic vehicle and equipment identification – Electronic registration identification (ERI) for vehicles – Part 3: Vehicle data		
			ISO 24534-4:2010	Automatic vehicle and equipment identification – Electronic registration identification (ERI) for vehicles – Part 4: Secure communications using asymmetrical techniques		

Work area	FG-SSC deliverable(s) related to this work area	SDO working on this area	Document number released by this SDO	Corresponding document title	Standardization gap in this area	Future needs and suggestions to SG5
			ISO 24534-5:2011	Intelligent transport systems – Automatic vehicle and equipment identification – Electronic Registration Identification (ERI) for vehicles – Part 5: Secure communications using symmetrical techniques		
			ISO 24535:2007	Intelligent transport systems – Automatic vehicle identification – Basic electronic registration identification (Basic ERI)		
			ISO 24978:2009	Intelligent transport systems – ITS Safety and emergency messages using any available wireless media – Data registry procedures		
			ISO/TR 25100:2012	Intelligent transport systems – Systems architecture – Harmonization of ITS data concepts		
			ISO/TR 25102:2008	Intelligent transport systems – System architecture – 'Use Case' pro-forma template		
			ISO/TR 25104:2008	Intelligent transport systems – System architecture, taxonomy, terminology and data modelling – Training requirements for ITS architecture		
			ISO/TS 25110:2013	Electronic fee collection – Interface definition for on-board account using integrated circuit card (ICC)		
			ISO 25111:2009	Intelligent transport systems – Communications access for land mobiles (CALM) – General requirements for using public networks		
			ISO 25112:2010	Intelligent transport systems – Communications access for land mobiles (CALM) – Mobile wireless broadband using IEEE 802.16		

Work area	FG-SSC deliverable(s) related to this work area	SDO working on this area	Document number released by this SDO	Corresponding document title	Standardization gap in this area	Future needs and suggestions to SG5
			ISO 25113:2010	Intelligent transport systems – Communications access for land mobiles (CALM) – Mobile wireless broadband using HC-SDMA		
			ISO/TS 25114:2010	Intelligent transport systems – Probe data reporting management (PDRM)		
			ISO 26683-1:2013	Intelligent transport systems – Freight land conveyance content identification and communication – Part 1: Context, architecture and referenced standards		
			ISO 26683-2:2013	Intelligent transport systems – Freight land conveyance content identification and communication – Part 2: Application interface profiles		
			ISO/TR 26999:2012	Intelligent transport systems – Systems architecture – Use of process-oriented methodology in ITS International Standards and other deliverables		
			ISO/TR 28682:2008	Intelligent transport systems – Joint APEC-ISO study of progress to develop and deploy ITS standards		
			ISO 29281-1:2013	Intelligent transport systems – Communication access for land mobiles (CALM) – Non-IP networking – Part 1: Fast networking & transport layer protocol (FNTF)		
			ISO 29281-2:2013	Intelligent transport systems – Communication access for land mobiles (CALM) – Non-IP networking – Part 2: Legacy system support		
			ISO 29282:2011	Intelligent transport systems – Communications access for land mobiles (CALM) – Satellite networks		



Work area	FG-SSC deliverable(s) related to this work area	SDO working on this area	Document number released by this SDO	Corresponding document title	Standardization gap in this area	Future needs and suggestions to SG5
			ISO 29283:2011	ITS CALM Mobile Wireless Broadband applications using Communications in accordance with IEEE 802.20		
			ISO/TS 29284:2012	Intelligent transport systems – Event-based probe vehicle data		
(*) NOTE - Other standards being developed, see <a href="http://itu.int/ITU-T/workprog/wp_search.aspx?q=27/16">http://itu.int/ITU-T/workprog/wp_search.aspx?q=27/16</a> (**) NOTE - Also a number of standards under development, see <a href="http://www.iso.org/iso/home/store/catalogue_tc/catalogue_tc_browse.htm?commid=54706&amp;development=on">http://www.iso.org/iso/home/store/catalogue_tc/catalogue_tc_browse.htm?commid=54706&amp;development=on</a>						

### 3.2.3 Logistics

The services and applications of logistics include but are not limited to:

- Supply chain service
- Business intelligence
- Electronic payment

FG-SSC has a Technical Report on key performance indicators (KPIs) which includes some information on the development of economy.

The GS1 standard is mainly about the objects management in supply chain and is accepted widely as an international standard. It is not very related to other similar industries in SSC such as: business intelligence and ITS.

It is suggested to develop a guideline for applications on logistics in SSC.

Work area	FG-SSC deliverable(s) related to this work area	SDO working on this area	Document number released by this SDO	Corresponding document title	Standardization gap in this area	Future needs and suggestions to SG5
Supply chain service	KPIs for SSC [ITU-T L.KPIs-overview] [ITU-T L.KPIs-ICT] [ITU-T L.KPIs-impact]				Need to develop a use case on logistics in SSC applications	To develop a guideline for applications on logistics in SSC
Supply chain service		Globe Standard 1			Can be referenced of management of objects in the supply chain	
Business intelligence						
Electronic payment						
Impact		ITU-T SG5	ITU-T L Suppl.3	ITU-T L.1430 – Guidance on practical application of ITU-T L.1430 to a real-time navigation service		

### 3.2.4 Public safety

The services and applications of public safety for SSC include but are not limited to:

- Tackling natural disasters
- Emergency response

FG-SSC has released a Technical Report on overview of SSC and roles of ICT [ITU-T TR overview] which involves disasters alerts for SSC.

The ISO/TC 223 works on the organizational resilience, business continuity and emergency management in societal security. It is much related to the public safety in SSC. However, the widely utilized video surveillance is not in the mandate of TC223. Now TC 223 has been merged into a larger TC - ISO/TC 292.

The ISO/TC 262 works on risk management.

It is suggested to develop guidelines for applications on public safety in SSC.

Work area	FG-SSC deliverable(s) related to this work area	SDO working on this area	Document number released by this SDO	Corresponding document title	Standardization gap in this area	Future needs and suggestions to SG5
Societal security	overview of SSC and roles of ICT [ITU-T TR overview]	ISO/TC 292 (Security) (*)		Societal security – Organizational resilience – Principles and guidelines	Can be referenced for developing use cases on public safety in SSC applications	To develop guidelines for application on public safety in SSC
				Societal security – Business continuity management systems – Requirements		

Work area	FG-SSC deliverable(s) related to this work area	SDO working on this area	Document number released by this SDO	Corresponding document title	Standardization gap in this area	Future needs and suggestions to SG5
				Societal security – Business continuity management systems – Guidance		
				Societal security – Guidelines for exercises		
				Societal security – Emergency management – Requirements for incident response		
				Societal security – Emergency management – Public warning		
				Societal security – Emergency management – Colour-coded alert		
			ISO 12931:2012	Performance criteria for authentication solutions used to combat counterfeiting of material goods		
			ISO 16678:2014	Guidelines for interoperable object identification and related authentication systems to deter counterfeiting and illicit trade		
			ISO 22300:2012	Societal security – Terminology		
			ISO 22311:2012	Societal security – Video-surveillance – Export interoperability		
			ISO/TR 22312:2011	Societal security – Technological capabilities		
			ISO 22315:2014	Societal security – Mass evacuation – Guidelines for planning		
			ISO 22397:2014	Societal security – Guidelines for establishing partnering arrangements		
			ISO 22398:2013	Societal security – Guidelines for exercises		
			ISO 28000:2007	Specification for security management systems for the supply chain		
			ISO 28001:2007	Security management systems for the supply chain – Best practices for implementing supply chain security, assessments and plans – Requirements and guidance		

Work area	FG-SSC deliverable(s) related to this work area	SDO working on this area	Document number released by this SDO	Corresponding document title	Standardization gap in this area	Future needs and suggestions to SG5
			ISO 28002:2011	Security management systems for the supply chain – Development of resilience in the supply chain – Requirements with guidance for use		
			ISO 28003:2007	Security management systems for the supply chain – Requirements for bodies providing audit and certification of supply chain security management systems		
			ISO 28004-1:2007	Security management systems for the supply chain – Guidelines for the implementation of ISO 28000 – Part 1: General principles		
			ISO 28004-3:2014	Security management systems for the supply chain – Guidelines for the implementation of ISO 28000 – Part 3: Additional specific guidance for adopting ISO 28000 for use by medium and small businesses (other than marine ports)		
			ISO 28004-4:2014	Security management systems for the supply chain – Guidelines for the implementation of ISO 28000 – Part 4: Additional specific guidance on implementing ISO 28000 if compliance with ISO 28001 is a management objective		
Climate change adaptation and disaster prevention			ITU-T L.1500	Framework for information and communication technologies and adaptation to the effects of climate change		
Climate change adaptation and disaster prevention			ITU-T L.1501	Best practices on how countries can utilize ICTs to adapt to the effects of climate change		
Tackling natural disasters	Integrated management for SSC [ITU-T TR management]	ISO/TC 262 (Risk management)				To develop a series of standards of public safety for SSC
Emergency response	Integrated management for SSC [ITU-T TR management]					To develop a series of standards of public safety for SSC

Work area	FG-SSC deliverable(s) related to this work area	SDO working on this area	Document number released by this SDO	Corresponding document title	Standardization gap in this area	Future needs and suggestions to SG5
		ITU-T SG2	ITU-T E.107	Emergency Telecommunications Service (ETS) and Interconnection Framework for National Implementations of ETS		
			ITU-T E.123 Amendment 1	Notation for national and international telephone numbers, e-mail addresses and Web addresses: Contact information in case of emergency for mobile telephones		
			ITU-T E.161.1	Guidelines to select Emergency Number for public telecommunications networks		
			ITU-T Supplement 5 to Rec. ITU-T E.164	Guidance with regard to the selection of numbers for helplines for children		
(*) NOTE - see also the following link for deliverables under development: <a href="http://www.iso.org/iso/home/store/catalogue_tc/home/store/catalogue_tc/home/store/catalogue_tc/home/store/catalogue_tc/home/store/catalogue_tc/home/store/catalogue_tc/catalogue_tc/browse.htm?commid=5259148&amp;development=on">http://www.iso.org/iso/home/store/catalogue_tc/home/store/catalogue_tc/home/store/catalogue_tc/home/store/catalogue_tc/home/store/catalogue_tc/home/store/catalogue_tc/catalogue_tc/browse.htm?commid=5259148&amp;development=on</a>						

### 3.2.5 Healthcare

The services and applications of healthcare include but are not limited to:

- E-health monitoring service
- Health informatics
- Medical informatics

FG-SSC currently has no Technical Report on this topic.

WHO, CEN/TC 251, ISO/TC215, ITU-T SG16, ITU-T SG13, ITU-T FG M2M are working on all aspects in healthcare standards covering from doctors and nurses to patients, from hospital to home and mobile fields. These standards are popular and widely used in the healthcare industry.

It is suggested to develop guidelines for applications on e-health in SSC.

Work area	FG-SSC deliverable(s) related to this work area	SDO working on this area	Document number released by this SDO	Corresponding document title	Standardization gap in this area	Future needs and suggestions to SG5
E-health		ITU-T Q28/16 (Multimedia framework for e-health applications)	ITU-T H.810	Interoperability design guidelines for personal health systems	Can be referenced for developing use cases on e-health in SSC applications	To develop guidelines for applications of e-health in SSC
			ITU-T HSTP-H810	Introduction to the ITU-T H.810 Continua Design Guidelines		

Work area	FG-SSC deliverable(s) related to this work area	SDO working on this area	Document number released by this SDO	Corresponding document title	Standardization gap in this area	Future needs and suggestions to SG5
			ITU-T H.821	ITU-T H.810 personal health devices conformance: Health record network (HRN) interface		
			ITU-T H.831-H.850	ITU-T H.810 conformance testing		
			ITU-T H.860	Multimedia e-health data exchange services: Data schema and supporting services		
		ITU-T SG13 (Future networks, including cloud computing, mobile and next-generation networks)	ITU-T Y.2065	Service and capability requirements for e-health monitoring services		
M2M e-health		ITU-T FG M2M (Focus Group on Machine-to-Machine Service Layer)		M2M enabled ecosystems – e-health		
				M2M use cases – e-health		
E-health		WHO		International Classification of Disease (ICD)-10		
				National eHealth Strategy Toolkit		
		ITU-T SG16	ITU-T H.810	Interoperability design guidelines for personal health systems		Second edition under preparation (H.810.R, H.HRN-IF, H.TPL-IF, H.WAN-IF, H.WAN-IF.1, H.WAN-IF.2, H.WAN-IF.3, H.WAN-IF.4)
			ITU-T HSTP-H810	Technical Paper: Introduction to the ITU-T H.810 Continua Design Guidelines		
			ITU-T H.860	Multimedia e-health data exchange services: data schema and supporting services		
			ITU-T H.821	Conformance for ITU-T H.810 personal health devices: Health record network interface		



Work area	FG-SSC deliverable(s) related to this work area	SDO working on this area	Document number released by this SDO	Corresponding document title	Standardization gap in this area	Future needs and suggestions to SG5
			ITU-T H.831	Conformance for ITU-T H.810 personal health devices: WAN interface Part 1: Web services interoperability: Sender		
			ITU-T H.832	Conformance for ITU-T H.810 personal health devices: WAN interface Part 2: Web services interoperability: Receiver		
			ITU-T H.833	Conformance for ITU-T H.810 personal health devices: WAN interface Part 3: SOAP/ATNA: Sender		
			ITU-T H.834	Conformance for ITU-T H.810 personal health devices: WAN interface Part 4: SOAP/ATNA: Receiver		
			ITU-T H.835	Conformance for ITU-T H.810 personal health devices: WAN interface Part 5: PCD-01 HL7 messages: Sender		
			ITU-T H.836	Conformance for ITU-T H.810 personal health devices: WAN interface Part 6: PCD-01 HL7 messages: Receiver		
			ITU-T H.837	Conformance for ITU-T H.810 personal health devices: WAN interface Part 7: Consent management: Sender		
			ITU-T H.838	Conformance for ITU-T H.810 personal health devices: WAN interface Part 8: Consent management: Receiver		
			ITU-T H.840	Conformance for ITU-T H.810 personal health devices: PAN/LAN/TAN: USB host		
			ITU-T H.841	Conformance for ITU-T H.810 personal health devices: PAN/LAN/TAN interface Part 1: Optimized exchange protocol: Agent		
			ITU-T H.842	Conformance for ITU-T H.810 personal health devices: PAN/LAN/TAN interface Part 2: Optimized exchange protocol: Manager		
			ITU-T H.843	Conformance for ITU-T H.810 personal health devices: PAN/LAN/TAN interface Part 3: Continua Design Guidelines: Agent		

Work area	FG-SSC deliverable(s) related to this work area	SDO working on this area	Document number released by this SDO	Corresponding document title	Standardization gap in this area	Future needs and suggestions to SG5
			ITU-T H.844	Conformance for ITU-T H.810 personal health devices: PAN/LAN/TAN interface Part 4: Continua Design Guidelines: Manager		
			ITU-T H.845.1	Conformance for ITU-T H.810 personal health devices: PAN/LAN/TAN interface Part 5A: Weighing scales: Agent		
			ITU-T H.845.2	Conformance for ITU-T H.810 personal health devices: PAN/LAN/TAN interface Part 5B: Glucose meter: Agent		
			ITU-T H.845.3	Conformance for ITU-T H.810 personal health devices: PAN/LAN/TAN interface Part 5C: Pulse oximeter: Agent		
			ITU-T H.845.4	Conformance for ITU-T H.810 personal health devices: PAN/LAN/TAN interface Part 5D: Blood pressure monitor: Agent		
			ITU-T H.845.5	Conformance for ITU-T H.810 personal health devices: PAN/LAN/TAN interface Part 5E: Thermometer: Agent		
			ITU-T H.845.6	Conformance for ITU-T H.810 personal health devices: PAN/LAN/TAN interface Part 5F: Cardiovascular fitness and activity monitor: Agent		
			ITU-T H.845.7	Conformance for ITU-T H.810 personal health devices: PAN/LAN/TAN interface Part 5G: Strength fitness equipment: Agent		
			ITU-T H.845.8	Conformance for ITU-T H.810 personal health devices: PAN/LAN/TAN interface Part 5H: Independent living activity hub: Agent		
			ITU-T H.845.9	Conformance for ITU-T H.810 personal health devices: PAN/LAN/TAN interface Part 5I: Medication adherence monitor: Agent		
			ITU-T H.845.11	Conformance for ITU-T H.810 personal health devices: PAN/LAN/TAN interface Part 5K: Peak expiratory flow monitor: Agent		

Work area	FG-SSC deliverable(s) related to this work area	SDO working on this area	Document number released by this SDO	Corresponding document title	Standardization gap in this area	Future needs and suggestions to SG5
			ITU-T H.845.12	Conformance for ITU-T H.810 personal health devices: PAN/LAN/TAN interface Part 5L: Body composition analyser: Agent		
			ITU-T H.845.13	Conformance for ITU-T H.810 personal health devices: PAN/LAN/TAN interface Part 5M: Basic electrocardiograph: Agent		
			ITU-T H.845.14	Conformance for ITU-T H.810 personal health devices: PAN/LAN/TAN interface Part 5N: International normalized ratio: Agent		
			ITU-T H.846	Conformance for ITU-T H.810 personal health devices: PAN/LAN/TAN interface Part 6: Device specializations: Manager		
			ITU-T H.847	Conformance for ITU-T H.810 personal health devices: PAN/LAN/TAN interface Part 7: Bluetooth low energy: Agent		
			ITU-T H.848	Conformance for ITU-T H.810 personal health devices: PAN/LAN/TAN interface Part 8: Bluetooth low energy: Manager		
			ITU-T H.849	Conformance for ITU-T H.810 personal health devices: PAN/LAN/TAN interface Part 9: Transcoding for Bluetooth low energy: Agent		
			ITU-T H.850	Conformance for ITU-T H.810 personal health devices: PAN/LAN/TAN Interface Part 10: Transcoding for Bluetooth low energy: Manager		
			ITU-T H.OPVQ	E-health application for on-flight and post-flight virtual quarantine		
		CEN/TC 251 (Health informatics)	EN 1068	Health informatics – Registration of coding systems		
			EN 12264	Health informatics – Categorical structures for systems of concepts		
			EN 12435	Health informatics – Expression of results of measurements in health sciences		

Work area	FG-SSC deliverable(s) related to this work area	SDO working on this area	Document number released by this SDO	Corresponding document title	Standardization gap in this area	Future needs and suggestions to SG5
			EN 13940-1	Health informatics – System of concepts to support continuity of care – Part 1: Basic concepts		
			EN 14463	Health informatics – A syntax to represent the content of medical classification systems – ClaML		
			EN 14485	Health informatics – Guidance for handling personal health data in international applications in the context of the EU data protection directive		
			EN 1828	Health informatics – Categorical structure for classifications and coding systems of surgical procedures		
			CEN/TR 15253	Health informatics – Quality of service requirements for health information interchange		
			CEN/TR 15299	Health informatics – Safety procedures for identification of patients and related objects		
			CEN/TS 15260	Health informatics – Classification of safety risks from health informatics products		
			EN 12251	Health informatics – Secure User Identification for Health Care – Management and Security of Authentication by Passwords		
			CEN/TS 14822-4	Health informatics – General purpose information components – Part 4: Message headers		
			EN 1064	Health informatics – Standard communication protocol – Computer-assisted electrocardiography		
			ENV 12612	Medical informatics – Messages for the exchange of healthcare administrative information		
			ENV 13607	Health informatics – Messages for the exchange of information on medicine prescriptions		
			ENV 13609-2	Health informatics – Messages for maintenance of supporting information in healthcare systems – Part 2: Updating of medical laboratory-specific information		

Work area	FG-SSC deliverable(s) related to this work area	SDO working on this area	Document number released by this SDO	Corresponding document title	Standardization gap in this area	Future needs and suggestions to SG5
			ENV 13730-2	Healthcare Informatics – Blood transfusion related messages – Part 2: Production related messages (BTR-PROD)		
			EN 12381	Health informatics – Time standards for healthcare specific problems		
			EN 13609-1	Health informatics – Messages for maintenance of supporting information in healthcare systems – Part 1: Updating of coding schemes		
			EN 14822	Health informatics – General purpose information components		
			EN 15521	Health informatics – Categorical structure for terminologies of human anatomy		
			ENV 12443	Medical Informatics – Healthcare Information Framework (HIF)		
			ENV 12537-1	Medical informatics – Registration of information objects used for EDI in healthcare – Part 1 : The Register		
			ENV 12611	Medical informatics – Categorical structure of systems of concepts – Medical devices		
		ISO/TC215 (Health informatics)	ISO 18104:2014	Health Informatics – Categorical structures for representation of nursing diagnoses and nursing actions in terminological systems (ISO 18104:2014)		
			ISO/TR 14639-1	Capacity-based eHealth architecture roadmap – Part 1: Overview of national eHealth initiatives		
			ISO/HL 7 10781	Electronic Health Record-System Functional Model, Release 1.1 (ISO 10781)		
			ISO/IEEE 11073-20601	Health informatics – Personal health device communication – Part 20601: Application profile – Optimized exchange protocol (ISO/IEEE 11073-20601:2010)		
			ISO 13606-1	Health informatics – Electronic health record communication – Part 1: Reference model		
			ISO 13606-2	Health informatics – Electronic health record communication – Part 2: Archetype interchange specification		

Work area	FG-SSC deliverable(s) related to this work area	SDO working on this area	Document number released by this SDO	Corresponding document title	Standardization gap in this area	Future needs and suggestions to SG5
			ISO 13606-3	Health informatics – Electronic health record communication – Part 3: Reference archetypes and term lists		
			ISO 13606-4	Health informatics – Electronic health record communication – Part 4: Security		
			ISO 13606-5	Health informatics – Electronic health record communication – Part 5: Interface specification (ISO 13606-5:2010)		
			ISO 21090	Health Informatics – Harmonized data types for information interchange (ISO 21090:2011)		
			ISO 13119	Health informatics – Clinical knowledge resources – Metadata		
			ISO/TS 14265	Classification of purposes for processing personal health information		
			ISO/TR 14292	Personal health records – Definition, scope and context		
			ISO 18308	Requirements for an electronic health record architecture		
			ISO/TR 20514	Electronic health record – Definition, scope and context		
			ISO/TS 21091	Health informatics – Directory services for healthcare providers, subjects of care and other entities		
			ISO/HL 7 21731:2014	HL7 version 3 – Reference information model – Release 4		
			ISO/TR 22221:2006	Good principles and practices for a clinical data warehouse		
			ISO/TS 29585:2010	Deployment of a clinical data warehouse		
			ISO/TR 21730:2007	Use of mobile wireless communication and computing technology in healthcare facilities – Recommendations for electromagnetic compatibility (management of unintentional electromagnetic interference) with medical devices		
			ISO/TR 25257:2009	Business requirements for an international coding system for medicinal products		
			ISO/TR 16056	Interoperability of telehealth systems and networks		
			ISO 27799:2008	Health informatics – Information security management in health using ISO/IEC 27002		



Work area	FG-SSC deliverable(s) related to this work area	SDO working on this area	Document number released by this SDO	Corresponding document title	Standardization gap in this area	Future needs and suggestions to SG5
			ISO/TR 11633-1:2009	Information security management for remote maintenance of medical devices and medical information systems – Part 1: Requirements and risk analysis		
			ISO/TR 11633-2:2009	Information security management for remote maintenance of medical devices and medical information systems - Part 2: Implementation of an information security management system (ISMS)		
			ISO 22857:2013	Guidelines on data protection to facilitate trans-border flows of personal health data		
			ISO 12052:2006	Digital imaging and communication in medicine (DICOM) including workflow and data management		
			ISO/TR 13128:2012	Clinical document registry federation		
			ISO 20301:2014	Health cards – General characteristics		
			ISO 21549	Patient healthcard data – Part 1: General structure (2013); Part 2: Common objects (2014); Part 3: Limited clinical data (2014); Part 4: Extended clinical data (2014); Part 5: Identification data (2008); Part 6: Administrative data (2008); Part 7: Medication data (2007); Part 8: Links (2010)		
			ISO 21667:2010	Health indicators conceptual framework		
			ISO/TS 25238:2007	Classification of safety risks from health software		
			ISO/HL 7 27953	Individual case safety reports (ICSRs) in pharmacovigilance – Part 1: Framework for adverse event reporting; Part 2: Human pharmaceutical reporting requirements for ICSR		
			ISO 10159:2011	Health informatics – Messages and communication – Web access reference manifest		
			ISO/IEEE 11073-00103:2015	Health informatics – Personal health device communication – Part 00103: Overview		

Work area	FG-SSC deliverable(s) related to this work area	SDO working on this area	Document number released by this SDO	Corresponding document title	Standardization gap in this area	Future needs and suggestions to SG5
			ISO/IEEE 11073-10101:2004	Health informatics – Point-of-care medical device communication – Part 10101: Nomenclature		
			ISO/IEEE 11073-10102:2014	Health informatics – Point-of-care medical device communication – Part 10102: Nomenclature – Annotated ECG		
			ISO/IEEE 11073-10103:2014	Health informatics – Point-of-care medical device communication – Part 10103: Nomenclature – Implantable device, cardiac		
			ISO/IEEE 11073-10201:2004	Health informatics – Point-of-care medical device communication – Part 10201: Domain information model		
			ISO/IEEE 11073-10404:2010	Health informatics – Personal health device communication – Part 10404: Device specialization – Pulse oximeter		
			ISO/IEEE 11073-10406:2012	Health informatics – Personal health device communication – Part 10406: Device specialization – Basic electrocardiograph (ECG) (1- to 3-lead ECG)		
			ISO/IEEE 11073-10407:2010	Health informatics – Personal health device communication – Part 10407: Device specialization – Blood pressure monitor		
			ISO/IEEE 11073-10408:2010	Health informatics – Personal health device communication – Part 10408: Device specialization – Thermometer		
			ISO/IEEE 11073-10415:2010	Health informatics – Personal health device communication – Part 10415: Device specialization – Weighing scale		
			ISO/IEEE 11073-10417:2014	Health informatics – Personal health device communication – Part 10417: Device specialization – Glucose meter		
			ISO/IEEE 11073-10418:2014	Health informatics – Personal health device communication – Part 10418: Device specialization – International Normalized Ratio (INR) monitor		
			ISO/IEEE 11073-10420:2012	Health informatics – Personal health device communication – Part 10420: Device specialization – Body composition analyzer		

Work area	FG-SSC deliverable(s) related to this work area	SDO working on this area	Document number released by this SDO	Corresponding document title	Standardization gap in this area	Future needs and suggestions to SG5
			ISO/IEEE 11073-10421:2012	Health informatics – Personal health device communication – Part 10421: Device specialization – Peak expiratory flow monitor (peak flow)		
			ISO/IEEE 11073-10441:2015	Health informatics – Personal health device communication – Part 10441: Device specialization – Cardiovascular fitness and activity monitor		
			ISO/IEEE 11073-10442:2015	Health informatics – Personal health device communication – Part 10442: Device specialization – Strength fitness equipment		
			ISO/IEEE 11073-10471:2010	Health informatics – Personal health device communication – Part 10471: Device specialization - Independant living activity hub		
			ISO/IEEE 11073-10472:2012	Health Informatics – Personal health device communication – Part 10472: Device specialization – Medication monitor		
			ISO/IEEE 11073-20101:2004	Health informatics – Point-of-care medical device communication – Part 20101: Application profiles – Base standard		
			ISO/IEEE 11073-30200:2004	Health informatics – Point-of-care medical device communication – Part 30200: Transport profile – Cable connected		
			ISO/IEEE 11073-30300:2004	Health informatics – Point-of-care medical device communication – Part 30300: Transport profile – Infrared wireless		
			ISO/IEEE 11073-30400:2012	Health informatics – Point-of-care medical device communication – Part 30400: Interface profile – Cabled Ethernet		
			ISO 11073-90101:2008	Health informatics – Point-of-care medical device communication – Part 90101: Analytical instruments – Point-of-care test		
			ISO 11073-91064:2009	Health informatics – Standard communication protocol – Part 91064: Computer-assisted electrocardiography		
			ISO/TS 11073-92001:2007	Health informatics – Medical waveform format – Part 92001: Encoding rules		

Work area	FG-SSC deliverable(s) related to this work area	SDO working on this area	Document number released by this SDO	Corresponding document title	Standardization gap in this area	Future needs and suggestions to SG5
			ISO 11238:2012	Health informatics – Identification of medicinal products – Data elements and structures for the unique identification and exchange of regulated information on substances		
			ISO 11239:2012	Health informatics – Identification of medicinal products – Data elements and structures for the unique identification and exchange of regulated information on pharmaceutical dose forms, units of presentation, routes of administration and packaging		
			ISO 11240:2012	Health informatics – Identification of medicinal products – Data elements and structures for the unique identification and exchange of units of measurement		
			ISO/TR 11487:2008	Health informatics – Clinical stakeholder participation in the work of ISO TC 215		
			ISO 11615:2012	Health informatics – Identification of medicinal products – Data elements and structures for the unique identification and exchange of regulated medicinal product information		
			ISO 11616:2012	Health informatics – Identification of medicinal products – Data elements and structures for the unique identification and exchange of regulated pharmaceutical product information		
			ISO/TR 11636:2009	Health Informatics – Dynamic on-demand virtual private network for health information infrastructure		
			ISO/TR 12300:2014	Health informatics – Principles of mapping between terminological systems		
			ISO/TR 12309:2009	Health informatics – Guidelines for terminology development organizations		
			ISO/TR 12773-1:2009	Business requirements for health summary records – Part 1: Requirements		
			ISO/TR 12773-2:2009	Business requirements for health summary records – Part 2: Environmental scan		

Work area	FG-SSC deliverable(s) related to this work area	SDO working on this area	Document number released by this SDO	Corresponding document title	Standardization gap in this area	Future needs and suggestions to SG5
			ISO 12967-1:2009	Health informatics – Service architecture – Part 1: Enterprise viewpoint		
			ISO 12967-2:2009	Health informatics – Service architecture – Part 2: Information viewpoint		
			ISO 12967-3:2009	Health informatics – Service architecture – Part 3: Computational viewpoint		
			ISO/TR 13054:2012	Knowledge management of health information standards		
			ISO 13120:2013	Health informatics – Syntax to represent the content of healthcare classification systems – Classification Markup Language (ClAML)		
			ISO/TS 13131:2014	Health informatics – Telehealth services – Quality planning guidelines		
			ISO/TS 13582:2013	Health informatics – Sharing of OID registry information		
			ISO/TS 14441:2013	Health informatics – Security and privacy requirements of EHR systems for use in conformity assessment		
			ISO/TR 14639-2:2014	Health informatics – Capacity-based eHealth architecture roadmap – Part 2: Architectural components and maturity model		
			ISO/TR 16056-1:2004	Health informatics – Interoperability of telehealth systems and networks – Part 1: Introduction and definitions		
			ISO/TR 16056-2:2004	Health informatics – Interoperability of telehealth systems and networks – Part 2: Real-time systems		
			ISO/TS 16058:2004	Health informatics – Interoperability of telelearning systems		
			ISO/TS 16791:2014	Health informatics – Requirements for international machine-readable coding of medicinal product package identifiers		
			ISO 17090-1:2013	Health informatics – Public key infrastructure – Part 1: Overview of digital certificate services		
			ISO 17090-2:2008	Health informatics – Public key infrastructure – Part 2: Certificate profile		

Work area	FG-SSC deliverable(s) related to this work area	SDO working on this area	Document number released by this SDO	Corresponding document title	Standardization gap in this area	Future needs and suggestions to SG5
			ISO 17090-3:2008	Health informatics – Public key infrastructure – Part 3: Policy management of certification authority		
			ISO 17090-4:2014	Health informatics – Public key infrastructure – Part 4: Digital Signatures for healthcare documents		
			ISO 17115:2007	Health informatics – Vocabulary for terminological systems		
			ISO/TS 17117:2002	Health informatics – Controlled health terminology – Structure and high-level indicators		
			ISO/TR 17119:2005	Health informatics - Health informatics profiling framework		
			ISO 17432:2004	Health informatics – Messages and communication – Web access to DICOM persistent objects		
			ISO/TS 17439:2014	Health informatics – Development of terms and definitions for health informatics glossaries		
			ISO/TR 17791:2013	Health informatics – Guidance on standards for enabling safety in health software		
			ISO/TS 17938:2014	Health informatics – Semantic network framework of traditional Chinese medicine language system		
			ISO/TS 17948:2014	Health informatics – Traditional Chinese medicine literature metadata		
			ISO 18232:2006	Health Informatics – Messages and communication – Format of length limited globally unique string identifiers		
			ISO/TR 18307:2001	Health informatics – Interoperability and compatibility in messaging and communication standards – Key characteristics		
			ISO/TS 18530:2014	Health Informatics – Automatic identification and data capture marking and labelling – Subject of care and individual provider identification		



Work area	FG-SSC deliverable(s) related to this work area	SDO working on this area	Document number released by this SDO	Corresponding document title	Standardization gap in this area	Future needs and suggestions to SG5
			ISO 18812:2003	Health informatics – Clinical analyser interfaces to laboratory information systems – Use profiles		
			ISO/TR 19231:2014	Health informatics – Survey of mHealth projects in low and middle income countries (LMIC)		
			ISO 20302:2014	Health informatics – Health cards – Numbering system and registration procedure for issuer identifiers		
			ISO/TR 21089:2004	Health informatics – Trusted end-to-end information flows		
			ISO 21091:2013	Health informatics – Directory services for healthcare providers, subjects of care and other entities		
			ISO/TS 21298:2008	Health informatics – Functional and structural roles		
			ISO/TS 21547:2010	Health informatics – Security requirements for archiving of electronic health records – Principles		
			ISO/TR 21548:2010	Health informatics – Security requirements for archiving of electronic health records – Guidelines		
			ISO/HL7 21731:2014	Health informatics – HL7 version 3 – Reference information model – Release 4		
			ISO/TS 22220:2011	Health informatics – Identification of subjects of health care		
			ISO/TR 22221:2006	Health informatics - Good principles and practices for a clinical data warehouse		
			ISO/TS 22224:2009	Health informatics – Electronic reporting of adverse drug reactions		
			ISO 22600-1:2014	Health informatics – Privilege management and access control – Part 1: Overview and policy management		
			ISO 22600-2:2014	Health informatics – Privilege management and access control – Part 2: Formal models		

Work area	FG-SSC deliverable(s) related to this work area	SDO working on this area	Document number released by this SDO	Corresponding document title	Standardization gap in this area	Future needs and suggestions to SG5
			ISO 22600-3:2014	Health informatics – Privilege management and access control – Part 3: Implementations		
			ISO/TS 22789:2010	Health informatics – Conceptual framework for patient findings and problems in terminologies		
			ISO/TR 22790:2007	Health informatics – Functional characteristics of prescriber support systems		
			ISO/TS 25237:2008	Health informatics – Pseudonymization		
			ISO 25720:2009	Health informatics – Genomic Sequence Variation Markup Language (GSVML)		
			ISO/TS 27527:2010	Health informatics – Provider identification		
			ISO 27789:2013	Health informatics – Audit trails for electronic health records		
			ISO/TS 27790:2009	Health informatics – Document registry framework		
			ISO 27799:2008	Health informatics – Information security management in health using ISO/IEC 27002		
			ISO/TR 27809:2007	Health informatics – Measures for ensuring patient safety of health software		
			ISO/HL7 27931:2009	Data Exchange Standards – Health Level Seven Version 2.5 – An application protocol for electronic data exchange in healthcare environments		
			ISO/HL7 27932:2009	Data Exchange Standards – HL7 Clinical Document Architecture, Release 2		
			ISO/HL7 27951:2009	Health informatics – Common terminology services, release 1		
			ISO/TR 28380-1:2014	Health informatics – IHE global standards adoption – Part 1: Process		
			ISO/TR 28380-2:2014	Health informatics – IHE global standards adoption – Part 2: Integration and content profiles		

Work area	FG-SSC deliverable(s) related to this work area	SDO working on this area	Document number released by this SDO	Corresponding document title	Standardization gap in this area	Future needs and suggestions to SG5
			ISO/TR 28380-3:2014	Health informatics – IHE global standards adoption – Part 3: Deployment		
			ISO/TS 29585:2010	Health informatics – Deployment of a clinical data warehouse		
			IEC 80001-1:2010	Application of risk management for IT-networks incorporating medical devices – Part 1: Roles, responsibilities and activities		
			IEC/TR 80001-2-1:2012	Application of risk management for IT-networks incorporating medical devices – Part 2-1: Step by Step Risk Management of Medical IT-Networks; Practical Applications and Examples		
			IEC/TR 80001-2-2:2012	Application of risk management for IT-networks incorporating medical devices – Part 2-2: Guidance for the communication of medical device security needs, risks and controls		
			IEC/TR 80001-2-3:2012	Application of risk management for IT-networks incorporating medical devices – Part 2-3: Guidance for wireless networks		
			IEC/TR 80001-2-4:2012	Application of risk management for IT-networks incorporating medical devices – Part 2-4: General implementation guidance for Healthcare Delivery Organizations		
			IEC/TR 80001-2-5:2014	Application of risk management for IT-networks incorporating medical devices – Part 2-5: Application guidance – Guidance for distributed alarm systems		
			ISO/TR 80001-2-6:2014	Application of risk management for IT-networks incorporating medical devices – Part 2-6: Application guidance – Guidance for responsibility agreements		

Work area	FG-SSC deliverable(s) related to this work area	SDO working on this area	Document number released by this SDO	Corresponding document title	Standardization gap in this area	Future needs and suggestions to SG5
			ISO/TR 80001-2-7:2015	Application of risk management for IT-networks incorporating medical devices – Application guidance – Part 2-7: Guidance for Healthcare Delivery Organizations (HDOs) on how to self-assess their conformance with IEC 80001-1		

### 3.2.6 Governance of urban infrastructure

The services and applications of governance of urban governance include but are not limited to:

- Street lighting
- Urban landscape
- Urban pipeline network

FG-SSC has a Technical Report on integrated management for SSC which focuses on urban operations and services.

There is no international SDO related to the urban governance field, but some national SDOs such as ASCE (The American Society of Civil Engineers) has some urban facility management standards and technology documents.

It is suggested to develop a guideline for services and applications of urban governance for SSC.

Work area	FG-SSC deliverable(s) related to this work area	SDO working on this area	Document number released by this SDO	Corresponding document title	Standardization gap in this area	Future needs and suggestions to SG5
Urban operations and services	Integrated management for SSC [ITU-T TR management]					To develop a guideline for services and applications of urban governance
Street lighting						
Urban landscape						
Urban pipeline network	Smart water management for SSC [ITU-T TR water]				Only deal with water pipeline, need more general specifications	

### 3.2.7 Energy and resources management

The services and applications of energy and resources management include but are not limited to:

- Power supply
- Water supply and sanitation
- Gas supply

FG-SSC has a Technical Report on ICT infrastructure for SSC which a bit involves facilities of IoT.

The ISO, IEC and ITU-T are working on the smart grid and smart metering in energy and resources management. However, the scope and boundary of the standards is not limited to the region of a city, more efforts are needed to conduct integrated energy and resources management, including power, gas, water and sanitation in cities.

It is suggested to develop a guideline for applications on smart energy and resources management in SSC.

Work area	FG-SSC deliverable(s) related to this work area	SDO working on this area	Document number released by this SDO	Corresponding document title	Standardization gap in this area	Future needs and suggestions to SG5
Smart grid		ITU-T Q15/15, Q18/15	ITU-T Technical Paper G.9960/G.9961	Applications of ITU-T G.9960, ITU-T G.9961 transceivers for Smart Grid applications: Advanced metering infrastructure, energy management in the home and electric vehicles		
		ITU-T Q15/SG15 (Communications for Smart Grid)	ITU-T G.9901	Narrow-band orthogonal frequency division multiplexing power line communication transceivers - power spectral density specification		
			ITU-T G.9902	Narrow-band orthogonal frequency division multiplexing power line communication transceivers for ITU-T G.hnem networks		
			ITU-T G.9903	Narrow-band orthogonal frequency division multiplexing power line communication transceivers for G3-PLC networks		
			ITU-T G.9904	Narrow-band OFDM power line communication transceivers - PRIME		
	SSC infrastructure	ITU-T FG Smart (Focus Group on Smart Grid)		Smart grid overview	Can be referenced for developing a use case on smart grid in SSC applications	To develop guidelines for applications on smart grid in SSC
		ITU-T WP3/SG5	ITU-T L.1400			

Work area	FG-SSC deliverable(s) related to this work area	SDO working on this area	Document number released by this SDO	Corresponding document title	Standardization gap in this area	Future needs and suggestions to SG5
		IEC TC 57 (Power systems management and associated information exchange)	IEC 61970	Energy management systems – Application Program Interfaces (API)		
			IEC 61850	Communication systems for Distributed Energy Resources (DER)		
		ISO/IEC JTC 1 SG 1 Smart Cities				
		CEN/CENELEC/ETSI Joint Working Group on Smart Grid				
		CEN/CENELEC/ETSI Joint Working Group on Smart Meters				
Energy management		ISO/TC 242 (Energy Management)	ISO 50001:2011	Energy management systems – Requirements with guidance for use		
			ISO 50002:2014	Energy audits – Requirements with guidance for use		
			ISO 50003:2014	Energy management systems – Requirements for bodies providing audit and certification of energy management systems		
			ISO 50004:2014	Energy management systems – Guidance for the implementation, maintenance and improvement of an energy management system		
			ISO 50006:2014	Energy management systems – Measuring energy performance using energy baselines (EnB) and energy performance indicators (EnPI) – General principles and guidance		
			ISO 50015:2014	Energy management systems – Measurement and verification of energy performance of organizations – General principles and guidance		



Work area	FG-SSC deliverable(s) related to this work area	SDO working on this area	Document number released by this SDO	Corresponding document title	Standardization gap in this area	Future needs and suggestions to SG5
		ISO/IEC JPC 2 (Energy efficiency and renewable energy sources)	ISO/IEC 13273-1	Energy efficiency and renewable energy sources – Common international terminology – Part 1: Energy efficiency		
			ISO/IEC 13273-2	Energy efficiency and renewable energy sources – Common international terminology – Part 2: Renewable energy sources		
		ISO/TC 163 (Thermal performance and energy use in the built environment)	ISO 12655:2013	Energy performance of buildings – Presentation of measured energy use of buildings		
			ISO 16343:2013	Energy performance of buildings – Methods for expressing energy performance and for energy certification of buildings		
			ISO/TR 16344:2012	Energy performance of buildings – Common terms, definitions and symbols for the overall energy performance rating and certification		
			ISO 16346:2013	Energy performance of buildings – Assessment of overall energy performance		
Gas supply		ITU-T Q25/16 (IoT application and services)	ITU-T F.747.1	Capabilities of ubiquitous sensor networks (USN) for supporting requirements of smart metering services		To develop guidelines on using ICT in infrastructure in SSC
Water supply and sanitation	Smart water management for SSC [ITU-T TR water]	ITU-T Q25/16 (IoT application and services)	ITU-T F.747.6	Requirements of water quality assessment services in ubiquitous sensor network (USN)		To develop guidelines on using ICT in infrastructure in SSC
		ITU-T FG-SWM (Focus Group on Smart Water Management)				

Work area	FG-SSC deliverable(s) related to this work area	SDO working on this area	Document number released by this SDO	Corresponding document title	Standardization gap in this area	Future needs and suggestions to SG5
		ISO/TC 224 (Service activities relating to drinking water supply systems and wastewater systems) (*)	ISO 24512:2007	Activities relating to drinking water and wastewater services – Guidelines for the management of drinking water utilities and for the assessment of drinking water services		
			ISO 24510:2007	Activities relating to drinking water and wastewater services – Guidelines for the assessment and for the improvement of the service to users		
			ISO 24511:2007	Activities relating to drinking water and wastewater services – Guidelines for the management of drinking water utilities and for the assessment of drinking water services		

(\*) NOTE - also a number of deliverable under development:  
[http://www.iso.org/iso/home/store/catalogue\\_tc/home/store/catalogue\\_tc/home/store/catalogue\\_tc/home/store/catalogue\\_tc/home/store/catalogue\\_tc/browse.htm?commid=299764&development=on](http://www.iso.org/iso/home/store/catalogue_tc/home/store/catalogue_tc/home/store/catalogue_tc/home/store/catalogue_tc/home/store/catalogue_tc/browse.htm?commid=299764&development=on)

### 3.2.8 Environmental Protection

The services and applications of environmental protection include but are not limited to:

- Solid waste management
- E-waste management
- Pollution source monitoring
- Toxic substance monitoring
- Noise monitoring

FG-SSC currently has no technical report on this topic.

Some national SDOs are working on the standardization of this field.

It is suggested to develop a guideline for applications on environmental protection in SSC at first, then to develop a series of Specifications.

Work area	FG-SSC deliverable(s) related to this work area	SDO working on this area	Document number released by this SDO	Corresponding document title	Standardization gap in this area	Future needs and suggestions to SG5
ICT and environment		ITU-T WP3/SG5 (ICT and climate change)	ITU-T L.1400	Overview and general principles of methodologies for assessing the environmental impact of information and communication technologies		To develop guidelines for applications on environmental protection, need more efforts to develop a series of specifications
			ITU-T L.1410	Methodology for environmental life cycle assessment (LCA) of information and communication (ICT) goods, networks and services		
			ITU-T L Suppl. 2	ITU-T L.1410 – Case studies		
			ITU-T L.1420	Methodology for energy consumption and greenhouse gas emissions impact assessment of information and communication technologies in organizations		
			ITU-T L.1430	Methodology for assessment of the environmental impact of information and communication technology greenhouse gas and energy projects		
Resource utilization			ITU-T L.1100	Procedure for recycling rare metals in information and communication technology goods		
			ITU-T L.1101	Measurement methods to characterize rare metals in information and communication technology goods		
E-Waste			ITU-T L Suppl. 4	Guidelines for developing a sustainable e-waste management system		
			ITU-T L Suppl. 5:	Life-cycle management of ICT goods		
			ITU-T L.1000	Universal power adapter and charger solution for mobile terminals and other hand-held ICT devices		

Work area	FG-SSC deliverable(s) related to this work area	SDO working on this area	Document number released by this SDO	Corresponding document title	Standardization gap in this area	Future needs and suggestions to SG5
			ITU-T L.1001	External universal power adapter solutions for stationary information and communication technology devices		
			ITU-T L.1005	Test suites for assessment of the universal charger solution		
		ISO/TC 207 (Environmental management)	ISO Guide 64:2008	Guide for addressing environmental issues in product standards		
			ISO 14050:2009	Environmental management – Vocabulary		
			ISO 14051:2011	Environmental management – Material flow cost accounting – General framework		
			ISO/TR 14062:2002	Environmental management – Integrating environmental aspects into product design and development		
			ISO 14063:2006	Environmental management – Environmental communication – Guidelines and examples		
		ISO/TC 207/SC 1	ISO 14001:2004	Environmental management systems – Requirements with guidance for use		
			ISO 14004:2004	Environmental management systems – General guidelines on principles, systems and support techniques		
			ISO 14005:2010	Environmental management systems – Guidelines for the phased implementation of an environmental management system, including the use of environmental performance evaluation		
			ISO 14006:2011	Environmental management systems – Guidelines for incorporating ecodesign		
		ISO/TC 207/SC 2	ISO 14015:2001	Environmental management – Environmental assessment of sites and organizations (EASO)		
		ISO/TC 207/SC 3	ISO 14020:2000	Environmental labels and declarations – General principles		

Work area	FG-SSC deliverable(s) related to this work area	SDO working on this area	Document number released by this SDO	Corresponding document title	Standardization gap in this area	Future needs and suggestions to SG5
			ISO 14021:1999	Environmental labels and declarations – Self-declared environmental claims (Type II environmental labelling)		
			ISO 14024:1999	Environmental labels and declarations – Type I environmental labelling – Principles and procedures		
			ISO 14025:2006	Environmental labels and declarations – Type III environmental declarations – Principles and procedures		
		ISO/TC 207/SC 4	ISO 14031:2013	Environmental management – Environmental performance evaluation – Guidelines		
			ISO/TS 14033:2012	Environmental management – Quantitative environmental information – Guidelines and examples		
		ISO/TC 207/SC 5	ISO 14040:2006	Environmental management – Life cycle assessment – Principles and framework		
			ISO 14044:2006	Environmental management – Life cycle assessment – Requirements and guidelines		
			ISO 14045:2012	Environmental management – Eco-efficiency assessment of product systems – Principles, requirements and guidelines		
			ISO 14046:2014	Environmental management – Water footprint – Principles, requirements and guidelines		
			ISO/TR 14047:2012	Environmental management – Life cycle assessment – Illustrative examples on how to apply ISO 14044 to impact assessment situations		
			ISO/TS 14048:2002	Environmental management – Life cycle assessment – Data documentation format		
			ISO/TR 14049:2012	Environmental management – Life cycle assessment – Illustrative examples on how to apply ISO 14044 to goal and scope definition and inventory analysis		
			ISO/TS 14071:2014	Environmental management – Life cycle assessment – Critical review processes and reviewer competencies: Additional requirements and guidelines to ISO 14044:2006		

Work area	FG-SSC deliverable(s) related to this work area	SDO working on this area	Document number released by this SDO	Corresponding document title	Standardization gap in this area	Future needs and suggestions to SG5
			ISO/TS 14072:2014	Environmental management – Life cycle assessment – Requirements and guidelines for organizational life cycle assessment		
		ISO/TC 207/SC 7	ISO 14064-1:2006	Greenhouse gases – Part 1: Specification with guidance at the organization level for quantification and reporting of greenhouse gas emissions and removals		
			ISO 14064-2:2006	Greenhouse gases – Part 2: Specification with guidance at the project level for quantification, monitoring and reporting of greenhouse gas emission reductions or removal enhancements		
			ISO 14064-3:2006	Greenhouse gases – Part 3: Specification with guidance for the validation and verification of greenhouse gas assertions		
			ISO 14065:2013	Greenhouse gases – Requirements for greenhouse gas validation and verification bodies for use in accreditation or other forms of recognition		
			ISO 14066:2011	Greenhouse gases – Competence requirements for greenhouse gas validation teams and verification teams		
			ISO/TS 14067:2013	Greenhouse gases – Carbon footprint of products – Requirements and guidelines for quantification and communication		
			ISO/TR 14069:2013	Greenhouse gases – Quantification and reporting of greenhouse gas emissions for organizations – Guidance for the application of ISO 14064-1		

### 3.2.9 Climate change

The services and applications of ICT and climate change for SSC include but are not limited to:

- Tackling climate change in cities

FG-SSC has released a Technical Report on this topic [ITU-T TR climate].



It is suggested to develop a guideline for climate change adaptation for SSC.

Work area	FG-SSC deliverable(s) related to this work area	SDO working on this area	Document number released by this SDO	Corresponding document title	Standardization gap in this area	Future needs and suggestions to SG5
ICT and climate change	ICT for climate change adaptation in cities [ITU-T TR climate]	ITU-T WP3/SG5 (ICT and climate change)	ITU-T L.1400 series			To develop guidelines on climate change assessment (adaptation and mitigation) for SSC
			ITU-T L.1410	Methodology for environmental life cycle assessment (LCA) of information and communication (ICT) goods, networks and services		
			ITU-T L Suppl. 2	ITU-T L.1410 – Case studies		
			ITU-T L.1420	Methodology for energy consumption and greenhouse gas emissions impact assessment of information and communication technologies in organizations		
			ITU-T L.1430	Methodology for assessment of the environmental impact of information and communication technology greenhouse gas and energy projects		
			ITU-T L.1200	Direct current power feeding interface up to 400 V at the input to telecommunication and ICT equipment		
			ITU-T L.1201	Architecture of power feeding systems of up to 400 VDC		
			ITU-T L.1202	Methodologies for evaluating the performance of up to 400VDC power feeding system and its environmental impact		
			ITU-T L.1300	Best practices for green data centres		
			ITU-T L Suppl. 6	ITU-T L.1300 - Supplement on validation test of a data centre cooling method using renewable energy in a cold region		
			ITU-T L Suppl. 7	ITU-T L.1300 - Supplement on rationale for minimum data set for evaluating energy efficiency and for controlling data centre equipment in view of power saving		
			ITU-T L Suppl. 8	ITU-T L.1300 - Supplement on potential for primary energy savings in TLC/ICT centres through free cooling		

Work area	FG-SSC deliverable(s) related to this work area	SDO working on this area	Document number released by this SDO	Corresponding document title	Standardization gap in this area	Future needs and suggestions to SG5
			ITU-T L Suppl. 9	ITU-T L.1300 - Supplement on Case study of reduction of air-conditioning energy by optical fibre based thermometry		
			ITU-T L Suppl. 10	ITU-T L.1300 - Supplement on Verification experiments related to increase of efficiency of air-conditioning and control technologies at a data centre		
			ITU-T L Suppl. 11	ITU-T L.1300 - Supplement on Verification test and feasibility study of energy and space efficient cooling systems for data centres with high density ICT		
			ITU-T L Suppl. 12	ITU-T L.1300 - Supplement on experimental studies on plates and ducts installed at equipment inlets and outlets		
			ITU-T L.1301	Minimum data set and communication interface requirements for data center energy management		
			ITU-T L.1310	Energy efficiency metrics and measurement methods for telecommunication equipment		
			ITU-T L Suppl. 1: ITU-T L.1310	Supplement on energy efficiency for telecommunication equipment		
			ITU-T L.1320	Energy efficiency metrics and measurement for power and cooling equipment for telecommunications and data centres		
			ITU-T L.1321	Reference operational model and interface for improving energy efficiency of ICT network hosts		
			ITU-T L.1330	Energy efficiency measurement and metrics for telecommunication network		
			ITU-T L.1340	Informative values on the energy efficiency of telecommunication equipment		
		ISO Climate Change Coordinating Committee (CCCC) (*)				

(\*) NOTE - Final report will be delivered this year with a roadmap and gap analysis

### 3.2.10 District

The services and applications of smart district include but are not limited to:

- District service
- Home application

FG-SSC has a Technical Report on integrated management for SSC which a bit involves smart district<sup>2</sup>.

It is suggested to develop a guideline for smart district, including scenario, use cases, and security etc.

Work area	FG-SSC deliverable(s) related to this work area	SDO working on this area	Document number released by this SDO	Corresponding document title	Standardization gap in this area	Future needs and suggestions to SG5
Smart district	Integrated management in SSC [ITU-T TR management]	ISO/TC 268/SC 1 (Sustainable development in communities/ Smart community infrastructures)				To develop Recommendations for smart district, including scenario, use cases, and security etc.

### 3.2.11 Building and household

The services and applications of building and household include but are not limited to:

- Building management

FG-SSC has a Technical Report on Smart building for SSC which focuses on ICT impact on building and household.

---

<sup>2</sup> The understanding of smart community is ambiguous. Hence, it is suggested to use "district" instead of "community" to refer to regional area of a city.

Work area	FG-SSC deliverable(s) related to this work area	SDO working on this area	Document number released by this SDO	Corresponding document title	Standardization gap in this area	Future needs and suggestions to SG5
	Smart building for SSC [b-FG-SSC building]					To develop Recommendations for buildings and residential dwellings, including scenarios, use cases, best practice, and security etc
Building Automation		ISO/TC 205 Building Automation and Control System (BACS) Design	ISO 16484-1:2010	Building automation and control systems (BACS) – Part 1: Project specification and implementation		
			ISO 16484-2:2004	Building automation and control systems (BACS) – Part 2: Hardware		
			ISO 16484-3:2005	Building automation and control systems (BACS) – Part 3: Functions		
			ISO 16484-5:2014	Building automation and control systems (BACS) – Part 5: Data communication protocol		
			ISO 16484-6:2014	Building automation and control systems (BACS) – Part 6: Data communication conformance testing More details		
		ISO/IEC JTC 1/SC 25	ISO/IEC 18012-1:2004	Information technology – Home Electronic System – Guidelines for product interoperability – Part 1: Introduction		
			ISO/IEC TR 14543-4:2002	Information technology – Home Electronic System (HES) architecture – Part 4: Home and building automation in a mixed-use building		
		ISO/IEC JTC 1/SC 27	ISO/IEC TR 27019:2013	Information technology – Security techniques – Information security management guidelines based on ISO/IEC 27002 for process control systems specific to the energy utility industry		
		ISO/TC 184/SC 4	ISO 10303-225:1999	Industrial automation systems and integration – Product data representation and exchange – Part 225: Application protocol: Building elements using explicit shape representation		

Work area	FG-SSC deliverable(s) related to this work area	SDO working on this area	Document number released by this SDO	Corresponding document title	Standardization gap in this area	Future needs and suggestions to SG5
			ISO/TS 10303-325:2004	Industrial automation systems and integration – Product data representation and exchange – Part 325: Abstract test suite: Building elements using explicit shape representation		
			ISO/TS 10303-1143:2005	Industrial automation systems and integration – Product data representation and exchange – Part 1143: Application module: Building component		
			ISO/TS 10303-1145:2005	Industrial automation systems and integration – Product data representation and exchange – Part 1145: Application module: Building structure		
			ISO/TS 10303-1144:2005	Industrial automation systems and integration – Product data representation and exchange – Part 1144: Application module: Building item		
			ISO/TS 10303-1146:2005	Industrial automation systems and integration – Product data representation and exchange – Part 1146: Application module: Location in building-More details		
EMC issues in home networks		ITU-T SG5, WP2/5 (Electromagnetic fields: emission, immunity and human exposure)	ITU-T K.74	EMC, resistibility and safety requirements for home network devices		
			ITU-T K.106	Techniques to mitigate interference between radio devices and cable or equipment connected to wired broadband networks and cable television networks		

### 3.3 Information and communication technology standards

#### 3.3.1 SSC framework, architecture and information model

FG-SSC has release several Technical Reports on SSC terms and definitions, characteristics and attributes, and infrastructure that concentrates on ICT infrastructure [ITU-T TR SSC def] [ITU-T TR overview] [b-FG-SSC infrastructure].

It is suggested to develop generic standards on terms and definitions, characteristics, requirements and capabilities, ICT infrastructure/services available in SSC etc. including scenario, use cases, and security.

Work area	FG-SSC deliverable(s) related to this work area	SDO working on this area	Document number released by this SDO	Corresponding document title	Standardization gap in this area	Future needs and suggestions to SG5
SSC framework	SSC infrastructure [b-FG-SSC infrastructure]					To develop Recommendations for: <ul style="list-style-type: none"> <li>- terms and definitions related to SSC from an ICT perspective.</li> <li>- characteristics, high-level requirements and general capabilities of SSCs.</li> <li>- information model of SSC from a spatio-temporal perspective.</li> <li>- ICT infrastructure/services available in SSC/ architecture framework and technical requirements of SSC.</li> </ul>

#### 3.3.2 Network and information security

FG-SSC has released a technical report on SSC security which concentrates on Cyber-security, data protection and cyber-resilience in smart sustainable cities [ITU-T TR security].

It is suggested to develop guidelines for network and information security in SSC.

Work area	FG-SSC deliverable(s) related to this work area	SDO working on this area	Document number released by this SDO	Corresponding document title	Standardization gap in this area	Future needs and suggestions to SG5
Cyber security	SSC security [ITU-T TR security]	ITU-T SG17 (security)	ITU-T X.1034 (revised)	Framework for extensible authentication protocol (EAP)-based authentication and key management		To develop guidelines for network and information security in SSC.
			ITU-T X.1037	Technical security guideline on deploying IPv6		



Work area	FG-SSC deliverable(s) related to this work area	SDO working on this area	Document number released by this SDO	Corresponding document title	Standardization gap in this area	Future needs and suggestions to SG5
			ITU-T X.1051	Information security management guidelines for telecommunications organizations based on ISO IEC 27002		
			ITU-T X.1052	Information security management framework		
			ITU-T X.1054	Information technology – Security techniques – Governance of information security		
			ITU-T X.1055	Risk management and risk profile guidelines for telecommunication organizations		
			ITU-T X.1056	Security incident management guidelines for telecommunications organizations		
			ITU-T X.1057	Asset management guidelines in telecommunication organizations		
			ITU-T X.1205	Overview of cybersecurity		
			ITU-T X.1209	Capabilities and their context scenarios for cybersecurity information sharing and exchange		
			ITU-T X.1207	Guidelines for telecommunication service providers for addressing the risk of spyware and potentially unwanted software		
			ITU-T X.1208	A cybersecurity indicator of risk to enhance confidence and security in the use of telecommunication/information and communication technologies		
			ITU-T X.1209	Capabilities and their context scenarios for cybersecurity information sharing and exchange		
			ITU-T X.1210	Overview of source-based security troubleshooting mechanisms for Internet protocol-based networks		
			ITU-T X.1500	Overview of cybersecurity information exchange (CYBEX)		
			ITU-T X.1520	Common vulnerabilities and exposures		
			ITU-T X.1521	Common vulnerability scoring system		
			ITU-T X.1524	Common weakness enumeration		
			ITU-T X.1526	Open vulnerability and assessment language		

Work area	FG-SSC deliverable(s) related to this work area	SDO working on this area	Document number released by this SDO	Corresponding document title	Standardization gap in this area	Future needs and suggestions to SG5
			ITU-T X.1570	Discovery mechanisms in the exchange of cybersecurity information		
			ITU-T X.1111	Framework of security technologies for home network		
			ITU-T X.1113	Guideline on user authentication mechanisms for home network services		
			ITU-T X.1114	Authorization framework for home networks		
			ITU-T X.1171	Threats and requirements for protection of personally identifiable information in applications using tag-based identification		
			ITU-T X.1311	Information technology – Security framework for ubiquitous sensor networks		
			ITU-T X.1312	Ubiquitous sensor network middleware security guidelines		
			ITU-T X.1313	Security requirements for wireless sensor network routing		
			ITU-T X.1141	Security Assertion Markup Language (SAML 2.0)		
			ITU-T X.1153	Management framework of a one time password-based authentication service		
			ITU-T X.1151	Guideline on secure password-based authentication protocol with key exchange		
			ITU-T X.1152	Secure end-to-end data communication techniques using trusted third party services		
			ITU-T X.1154	General framework of combined authentication on multiple identity service provider environments		
			ITU-T X.1156	Non-repudiation framework based on a one time password		
			ITU-T X.1161	Framework for secure peer-to-peer communications		
			ITU-T X.1162	Security architecture and operations for peer-to-peer networks		
			ITU-T X.1164	Use of service providers' user authentication infrastructure to implement public key infrastructure for peer-to-peer networks		
			ITU-T X.1600	Security framework for cloud computing		
			ITU-T X.1080.1	e-Health and world-wide telemedicines – Generic telecommunication protocol		

Work area	FG-SSC deliverable(s) related to this work area	SDO working on this area	Document number released by this SDO	Corresponding document title	Standardization gap in this area	Future needs and suggestions to SG5
			ITU-T X.1250	Baseline capabilities for enhanced global identity management and interoperability		
			ITU-T X.1253	Security guidelines for identity management systems		
			ITU-T X.1275	Guidelines on protection of personally identifiable information in the application of RFID technology		
			ITU-T X.509	Information technology – Open systems interconnection – The Directory: Public-key and attribute certificate frameworks		
Security of telecommunication and information systems regarding the electromagnetic environment		ITU-T SG5, WP2/5 (Electromagnetic fields: emission, immunity and human exposure)	ITU-T K.84	Test methods and guide against information leaks through unintentional electromagnetic emissions		
			ITU-T K.81	High-power electromagnetic immunity guide for telecommunication systems		
			ITU-T K.78	High altitude electromagnetic pulse immunity guide for telecommunication centres		
Information Technology/Security techniques		ISO/IEC JTC 1/SC 27 (Information Technology/ Security techniques)	ISO/IEC 27000	Information Technology — Security techniques — Information security management systems — Overview and vocabulary		
			ISO/IEC 27001	Information Technology — Security techniques — Information security management systems — Requirements		
			ISO/IEC 27002	Information Technology — Security techniques — Code of practice for information security controls		
			ISO/IEC 27003	Information Technology — Security techniques — Information security management systems implementation guidance		

Work area	FG-SSC deliverable(s) related to this work area	SDO working on this area	Document number released by this SDO	Corresponding document title	Standardization gap in this area	Future needs and suggestions to SG5
			ISO/IEC 27004	Information Technology — Security techniques — Information security management measurements		
			ISO/IEC 27005	Information Technology — Security techniques — Information security risk management		
			ISO/IEC 27006	Information Technology — Security techniques — Requirements for bodies providing audit and certification of information security management systems		
			ISO/IEC 27007	Information Technology — Security techniques — Guidelines for information security management systems auditing		
			ISO/IEC TR 27008	Information Technology — Security techniques — Guidelines for auditors on information security controls		
			ISO/IEC 27009	Information Technology — Security techniques — The use and application of ISO/IEC 27001 for sector/service-specific third-party accredited certifications		
			ISO/IEC 27010	Information Technology — Security techniques — Information security management for inter-sector and inter-organizational communications		
			ITU-T X.1051   ISO/IEC 27011	Information Technology — Security techniques — Information security management guidelines for telecommunications organizations based on ISO/IEC 27002		
			ISO/IEC 27013	Information Technology — Security techniques — Guidelines on the integrated implementation of ISO/IEC 27001 and ISO/IEC 20000-1		
			ITU-T X.1054   ISO/IEC 27014	Information Technology — Security techniques — Information security governance framework		
			ISO/IEC TR 27015	Information Technology — Security techniques — Information security management guidelines for financial services		
			ISO/IEC TR 27016	Information Technology — Security techniques — Information security management — Organizational economics		

Work area	FG-SSC deliverable(s) related to this work area	SDO working on this area	Document number released by this SDO	Corresponding document title	Standardization gap in this area	Future needs and suggestions to SG5
			ISO/IEC 27017	Information Technology — Security techniques — Code of practice for information security controls for cloud services based on ISO/IEC 27002		
			ISO/IEC 27018	Information Technology — Security techniques — Code of practice for PII protection in public clouds acting as PII processors		
			ISO/IEC TR 27019	Information Technology — Security techniques — Information security management guidelines based on ISO/IEC 27002 for process control systems specific to the energy industry		
			ISO/IEC 27021	Information Technology — Security techniques — Competence requirements for information security management systems professionals		
			ISO/IEC 27031	Information Technology — Security techniques — Guidelines for ICT readiness for business continuity		
			ISO/IEC 27032	Information Technology — Security techniques — Guidelines for cybersecurity		
			ISO/IEC 27033	Information Technology — Security techniques Network security		
			ISO/IEC 27034	Information Technology — Security techniques — Application security		
			ISO/IEC 27035	Information Technology — Security techniques — Information security incident management		
			ISO/IEC 27036	Information Technology — Security techniques — Information security for supplier relationships		
			ISO/IEC 27037	Information Technology — Security techniques — Guidelines for identification collection, acquisition and preservation of digital evidence		
			ISO/IEC 27038	Information Technology — Security techniques — Specification for digital redaction		
			ISO/IEC 27039	Information Technology — Security techniques — Selection, deployment and operation of intrusion detection and prevention systems (IDPS)		

Work area	FG-SSC deliverable(s) related to this work area	SDO working on this area	Document number released by this SDO	Corresponding document title	Standardization gap in this area	Future needs and suggestions to SG5
			ISO/IEC 27040	Information Technology — Security techniques — Storage Security		
			ISO/IEC 27041	Information Technology — Security techniques — Guidance on assuring suitability and adequacy of investigation methods		
			ISO/IEC 27042	Information Technology — Security techniques — Guidelines for the analysis and interpretation of digital evidence		
			ISO/IEC 27043	Information Technology — Security techniques — Investigation principles and processes		
			ISO/IEC 27044	Information Technology — Security techniques — Security Information and Event Management (SIEM)		
			ISO/IEC 27050	Information Technology — Security techniques — Electronic discovery		
			ISO/IEC 29003	Information Technology — Security techniques — Identity proofing		
			ISO/IEC 29100	Information Technology — Security techniques — A privacy framework		
			ISO/IEC 29101	Information Technology — Security techniques — A privacy reference architecture		
			ISO/IEC 29115	Information Technology — Security techniques — Entity authentication assurance framework		
			ISO/IEC 29134	Information Technology — Security techniques — Privacy impact assessment — Methodology		
			ISO/IEC 29146	Information Technology — Security techniques — A framework for access management		
			ISO/IEC 29147	Information Technology — Security techniques — Responsible vulnerability disclosure		
			ISO/IEC TR 29149	Information Technology — Security techniques — Best practices for the provision and use of time-stamping services		
			ISO/IEC 29151	Information Technology — Security techniques — Code of practice for the protection of personally identifiable information		



Work area	FG-SSC deliverable(s) related to this work area	SDO working on this area	Document number released by this SDO	Corresponding document title	Standardization gap in this area	Future needs and suggestions to SG5
			ISO/IEC 29190	Information Technology — Security techniques — Privacy capability assessment model		
			ISO/IEC 29191	Information Technology — Security techniques — Requirements for partially anonymous, partially unlinkable authentication		
			ISO/IEC 29193 TR	Information Technology — Security techniques — Secure system engineering principles and techniques		
			ISO/IEC TS 30104	Information Technology — Security techniques — Physical security attacks, mitigation techniques and security requirements		
			ISO/IEC 30111	Information Technology — Security techniques — Vulnerability handling processes		
			ISO/IEC 30127 TR	Information Technology — Security techniques — Detailing software penetration testing under ISO/IEC 15408 and ISO/IEC 18045 vulnerability analysis		
			ISO/IEC TR 14516	Information Technology — Security techniques — Guidelines on the use and management of Trusted Third Party services		
			ISO/IEC 15408	Information Technology — Security techniques — Evaluation criteria for IT security		
			ISO/IEC TR 15443	Information Technology — Security techniques — A framework for IT security assurance		
			ISO/IEC TR 15446	Information Technology — Security techniques — Guide for the production of protection profiles and security targets		
			ITU-T X.841   ISO/IEC 15816	Information Technology — Security techniques — Security information objects for access control		
			ITU-T X.843   ISO/IEC 15945	Information Technology — Security techniques — Specification of TTP services to support the application of digital signatures		
			ISO/IEC 18045	Information Technology — Security techniques — Evaluation methodology for IT security		

Work area	FG-SSC deliverable(s) related to this work area	SDO working on this area	Document number released by this SDO	Corresponding document title	Standardization gap in this area	Future needs and suggestions to SG5
			ISO/IEC 19249 TR	Information Technology — Security techniques — Catalogue of Architectural and Design Principles for Secure Products, Systems, and Applications		
			ISO/IEC TR 19608	Information Technology — Security techniques — Guidance for developing security and privacy functional requirements based on ISO/IEC 15408		
			ISO/IEC TR 19791	Information Technology — Security techniques — Security assessment for operational systems		
			ISO/IEC 19896	Information Technology — Security techniques — Competence requirements for information security testers and evaluators		
			ISO/IEC TR 20004	Information Technology — Security techniques — Refining software vulnerability analysis under ISO/IEC 15408 and ISO/IEC 18045		
			ISO/IEC 20008	Information Technology — Security techniques — Anonymous digital signatures		
			ISO/IEC 20009	Information Technology — Security techniques — Anonymous entity authentication		
			ISO/IEC PAS 20886	Information Technology — Security techniques — International Security, Trust, and Privacy Alliance — Privacy Framework		
			ISO/IEC 21827	Information Technology — Security techniques — Systems Security Engineering – Capability Maturity Model® (SSE-CMM®)		
			ISO/IEC 24760	Information Technology — Security techniques — A framework for identity management		

Work area	FG-SSC deliverable(s) related to this work area	SDO working on this area	Document number released by this SDO	Corresponding document title	Standardization gap in this area	Future needs and suggestions to SG5
Communication abstraction between NCAP and STIMS, Common TEDS and STIM commands		IEEE 1451 Working Group 0  ISO/IEC/IEEE 21450	1451.0-2007	IEEE Standard for a Smart Transducer Interface for Sensors and Actuators-Common Functions, Communication Protocols, and Transducer Electronic Data Sheet (TEDS) Formats		
Measurement Application programming model. Runs on multiple NCAPs		IEEE 1451 Working Group 1  ISO/IEC/IEEE 21451	1451.1-1999	IEEE Standard for a Smart Transducer Interface for Sensors and Actuators-Network Capable Application Processor (NCAP) Information Model		
Wired point-to-point link between NCAP and single STIM		IEEE 1451 Working Group 2	IEEE Std. 1451.2-1997	Transducer to Microprocessor Communication Protocols & Transducer Electronic Data Sheet TEDS Formats		
Wired multi-drop, 1 NCAP connected to multiple STIMS		IEEE 1451 Working Group 3	IEEE Std. 1451.3-2003	Digital Communication & TEDS Formats for Distributed Multidrop Systems		
Analog & Mixed Mode interface with TEDS		IEEE 1451 Working Group 4	IEEE Std. 1451.4-2004	Mixed-Mode Communication Protocols & TEDS Formats		
Wireless multi-drop, 1 NCAP connected to multiple STIMS		IEEE 1451 Working Group 5	IEEE Std. 1451.5-2007	Wireless Communication Protocols & Transducer Electronic Data Sheet (TEDS) Formats		
CAN bus to link NCAP to STIMS		IEEE 1451 Working Group 6				
		IEEE 1451 Working Group 7	IEEE Std. 1451.7-2010	Transducers to Radio Frequency Identification (RFID) Systems Communication Protocols and Transducer Electronic Data Sheet Formats		

### 3.3.3 Sensing layer standards

#### 3.3.3.1 IEEE 1451 Smart transducer interface

#### 3.3.3.2 Surface acoustic wave sensors

Work area	FG-SSC deliverable(s) related to this work area	SDO working on this area	Document number released by this SDO	Corresponding document title	Standardization gap in this area	Future needs and suggestions to SG5
Surface acoustic wave (SAW) filters		IEC 60862		Surface acoustic wave (SAW) filters of assessed quality	No standard interface in SAW filters.	To develop standards related to signal and communication interface of SAW sensors on the wireless detection of SSC
Surface acoustic wave (SAW) resonators		IEC 61019			No standard interface in SAW resonators.	To develop standards related to signal and communication interface of SAW sensors on the wireless detection of SSC

#### 3.3.3.3 ISO/IEC JTC1 SC31&AIM PDF417 Barcode symbols

Work area	FG-SSC deliverable(s) related to this work area	SDO working on this area	Document number released by this SDO	Corresponding document title	Standardization gap in this area	Future needs and suggestions to SG5
PDF417		ISO/IEC JTC1 SC31 (Information Technology/Automatic identification and data capture techniques)	ISO/IEC 15419:2009	Information technology – Automatic identification and data capture techniques – Bar code digital imaging and printing performance testing		
			ISO/IEC TR 19782:2006	Information technology – Automatic identification and data capture techniques – Effects of gloss and low substrate opacity on reading of bar code symbols		
			ISO/IEC 24723:2010	Information technology – Automatic identification and data capture techniques – GS1 Composite bar code symbology specification		
			ISO/IEC 24724:2011	Information technology – Automatic identification and data capture techniques – GS1 DataBar bar code symbology specification		

Work area	FG-SSC deliverable(s) related to this work area	SDO working on this area	Document number released by this SDO	Corresponding document title	Standardization gap in this area	Future needs and suggestions to SG5
			ISO/IEC 24728:2006	Information technology – Automatic identification and data capture techniques – MicroPDF417 bar code symbology specification		
			ISO/IEC 15420:2009	Information technology – Automatic identification and data capture techniques – EAN/UPC bar code symbology specification		
			ISO/IEC 24778:2008	Information technology – Automatic identification and data capture techniques – Aztec Code bar code symbology specification		
			ISO/IEC 15421:2010	Information technology – Automatic identification and data capture techniques – Bar code master test specifications		
			ISO/IEC 15423:2009	Information technology – Automatic identification and data capture techniques – Bar code scanner and decoder performance testing		
			ISO/IEC 15426-1:2006	Information technology – Automatic identification and data capture techniques – Bar code verifier conformance specification – Part 1: Linear symbols		
			ISO/IEC 15426-2:2005	Information technology – Automatic identification and data capture techniques – Bar code verifier conformance specification – Part 2: Two-dimensional symbols		
			ISO/IEC 15438:2006	Information technology – Automatic identification and data capture techniques – PDF417 bar code symbology specification		
			ISO/IEC 15415:2011	Information technology – Automatic identification and data capture techniques – Bar code symbol print quality test specification-Two-dimensional symbols		
			ISO/IEC 16022:2006	Information technology – Automatic identification and data capture techniques – Data Matrix bar code symbology specification		

Work area	FG-SSC deliverable(s) related to this work area	SDO working on this area	Document number released by this SDO	Corresponding document title	Standardization gap in this area	Future needs and suggestions to SG5
			ISO/IEC 16388:2007	Information technology – Automatic identification and data capture techniques – Code 39 bar code symbology specification		
			ISO/IEC 16390:2007	Information technology – Automatic identification and data capture techniques – Interleaved 2 of 5 bar code symbology specification		
			ISO/IEC 15416:2000	Information technology – Automatic identification and data capture techniques – Bar code print quality test specification – Linear symbols		
			ISO/IEC 18004:2006	Information technology – Automatic identification and data capture techniques – QR Code 2005 bar code symbology specification		
			ISO/IEC 15417:2007	Information technology – Automatic identification and data capture techniques – Code 128 bar code symbology specification		

### 3.3.3.4 ISO/IEC JTC1 SC31& EPC global RFID

Work area	FG-SSC deliverable(s) related to this work area	SDO working on this area	Document number released by this SDO	Corresponding document title	Standardization gap in this area	Future needs and suggestions to SG5
PDF417		ISO/IEC JTC1 SC31 (Information Technology/Automatic identification and data capture techniques)	ISO/IEC 19762-3:2008	Information technology – Automatic identification and data capture (AIDC) techniques – Harmonized vocabulary – Part 3: Radio frequency identification (RFID)		
			ISO/IEC/IEEE 21451-7:2011	Information technology – Smart transducer interface for sensors and actuators – Part 7: Transducer to radio frequency identification (RFID) systems communication protocols and Transducer Electronic Data Sheet (TEDS) formats		



Work area	FG-SSC deliverable(s) related to this work area	SDO working on this area	Document number released by this SDO	Corresponding document title	Standardization gap in this area	Future needs and suggestions to SG5
			ISO/IEC TR 24729-1:2008	Information technology – Radio frequency identification for item management – Implementation guidelines – Part 1: RFID-enabled labels and packaging supporting ISO/IEC 18000-6C		
			ISO/IEC TR 24729-2:2008	Information technology – Radio frequency identification for item management – Implementation guidelines – Part 2: Recycling and RFID tags		
			ISO/IEC TR 24729-3:2009	Information technology – Radio frequency identification for item management- Implementation guidelines – Part 3: Implementation and operation of UHF RFID Interrogator systems in logistics applications		
			ISO/IEC 24753:2011	Information technology – Radio frequency identification (RFID) for item management – Application protocol: encoding and processing rules for sensors and batteries		
			ISO/IEC 24791-1:2010	Information technology – Radio frequency identification (RFID) for item management – Software system infrastructure – Part 1: Architecture		
			ISO/IEC 24791-2:2011	Information technology – Radio frequency identification (RFID) for item management – Software system infrastructure – Part 2: Data management		
			ISO/IEC 24791-3:2014	Information technology – Radio frequency identification (RFID) for item management – Software system infrastructure – Part 3: Device management		
			ISO/IEC 24791-5:2012	Information technology – Radio frequency identification (RFID) for item management – Software system infrastructure – Part 5: Device interface		
			ISO/IEC 29143:2011	Information technology – Automatic identification and data capture techniques – Air interface specification for Mobile RFID interrogators		

Work area	FG-SSC deliverable(s) related to this work area	SDO working on this area	Document number released by this SDO	Corresponding document title	Standardization gap in this area	Future needs and suggestions to SG5
			ISO/IEC 29160:2012	Information technology – Radio frequency identification for item management – RFID Emblem		
			ISO/IEC 29167-1:2012	Information technology – Automatic identification and data capture techniques – Part 1: Air interface for security services and file management for RFID architecture		
			ISO/IEC 29173-1:2012	Information technology – Mobile item identification and management – Part 1: Mobile RFID interrogator device protocol for ISO/IEC 18000-63 Type C		
			ISO/IEC 29176:2011	Information technology – Mobile item identification and management – Consumer privacy-protection protocol for Mobile RFID services		
			ISO/IEC 15961:2004	Information technology – Radio frequency identification (RFID) for item management – Data protocol: application interface		
			ISO/IEC 15961-1:2013	Information technology – Radio frequency identification (RFID) for item management: Data protocol – Part 1: Application interface		
			ISO/IEC 15962:2013	Information technology – Radio frequency identification (RFID) for item management – Data protocol: data encoding rules and logical memory functions		

### 3.3.3.5 ZigBee/6Lowpan Wireless personal area network

There is a Technical Report on ICT infrastructure for SSC which involves facilities of IoT in FG-SSC [b-FG-SSC infrastructure].

It is suggested to develop guidelines for applications of Internet of Things in SSC.

Work area	FG-SSC deliverable(s) related to this work area	SDO working on this area	Document number released by this SDO	Corresponding document title	Standardization gap in this area	Future needs and suggestions to SG5
ZigBee		IEEE802.15.4(MAC and PHY layer protocol) ZigBee Alliance (Network Layer)		ZigBee Building Automation (Efficient commercial spaces)		To develop guidelines on applications of IoT in SSC, including scenarios, use cases and best practice.
				ZigBee Remote Control (Advanced remote controls)		
				ZigBee Smart Energy (Home energy savings)		
				Smart Energy Profile 2 (IP-based home energy management)		
				ZigBee Health Care (Health and fitness monitoring)		
				ZigBee Home Automation (Smart homes)		
				ZigBee Input Device (Easy-to-use touchpads, mice, keyboards, wands)		
				ZigBee Light Link (LED lighting control)		
				ZigBee Retail Services (Smarter shopping)		
				ZigBee Telecom Services (Value-added services)		
				ZigBee Network Devices (Assist and expand ZigBee networks)		
6LoWPAN		IEEE802.15.4(MAC and PHY layer protocol) IETF 6Lowpan (Network Layer)	IETF RFC4919	IPv6 over Low-Power Wireless Personal Area Networks (6LoWPANs): Overview, Assumptions, Problem Statement, and Goals		
			IETF RFC4944	Transmission of IPv6 Packets over IEEE 802.15.4 Networks		
			IETF RFC 6282	Compression Format for IPv6 Datagrams over IEEE 802.15.4-Based Networks		
			IETF RFC 6568	Design and Application Spaces for IPv6 over Low-Power Wireless Personal Area Networks (6LoWPANs)		

Work area	FG-SSC deliverable(s) related to this work area	SDO working on this area	Document number released by this SDO	Corresponding document title	Standardization gap in this area	Future needs and suggestions to SG5
			IETF RFC 6606	Problem Statement and Requirements for IPv6 over Low-Power Wireless Personal Area Network (6LoWPAN) Routing		
			IETF RFC 6775	Neighbor Discovery Optimization for IPv6 over Low-Power Wireless Personal Area Networks (6LoWPANs)		
			IETF RFC4861	6LoWPAN Bootstrapping and 6LoWPAN IPv6 ND Optimizations		

### 3.3.3.6 Global position system

There is a Technical Report on ICT infrastructure for SSC which involves facilities of IoT in FG-SSC [b-FG-SSC infrastructure].

It is suggested to develop a guideline for application on navigation using GPS in SSC.

Work area	FG-SSC deliverable(s) related to this work area	SDO working on this area	Document number released by this SDO	Corresponding document title	Standardization gap in this area	Future needs and suggestions to SG5
GPS		ISO/TC 213 (Dimensional and geometrical product specifications and verification)		Including 4 kinds: GPS system, finite difference GPS, GPS enhancement, GPS compatibility and interoperability.		To develop guidelines for various application on location and navigation using GPS in SSC

### 3.3.3.7 Video surveillance

There are Technical Reports on ICT infrastructure for SSC which involves facilities of IoT in FG-SSC [b-FG-SSC infrastructure], and integrated management for SSC [ITU-T TR management].

It is suggested to develop a guideline for applications and services using video in SSC.

Work area	FG-SSC deliverable(s) related to this work area	SDO working on this area	Document number released by this SDO	Corresponding document title	Standardization gap in this area	Future needs and suggestions to SG5
video surveillance		Open Network Video Interface Forum		ONVIF Network Interface Specification Set		To develop guidelines for applications and services using video in SSC
				ONVIF Profile Specification		
				ONVIF Test Specification		
				ONVIF Conformance Process Specification		

Work area	FG-SSC deliverable(s) related to this work area	SDO working on this area	Document number released by this SDO	Corresponding document title	Standardization gap in this area	Future needs and suggestions to SG5
				ONVIF Interface Guide Specification		
				ONVIF WSDL and XML Schemas Specifications		
		Physical Security Interoperability Alliance		Service Model		
				PSIA Common Metadata & Event Model		
				PSIA Common Security Model		
				IP Media Device specification		
				Recording and Content Management specification		
				Video Analytics specification		
				Area Control specification		

### 3.3.3.8 Smart metering

There are Technical Reports on ICT infrastructure for SSC which involves facilities of IoT in FG-SSC [b-FG-SSC infrastructure], water management [ITU-T TR water], and integrated management for SSC [ITU-T TR management].

It is suggested to develop a guideline for applications and services using smart metering technologies in SSC.

Work area	FG-SSC deliverable(s) related to this work area	SDO working on this area	Document number released by this SDO	Corresponding document title	Standardization gap in this area	Future needs and suggestions to SG5
Smart metering	Smart water management for SSC [ITU-T TR water]					To develop guidelines for applications using smart metering technologies in SSC
		ITU-T FG Smart (Focus Group on Smart Grid)		Use Cases for Smart Grid		
				Requirements of communication for Smart Grid		
				Smart Grid Architecture		
				Smart Grid Overview		
				Terminology		

### 3.3.4 Communication layer standards

#### 3.3.4.1 Ethernet

There is a Technical Report on ICT infrastructure for SSC which involves telecommunication facilities in FG-SSC [b-FG-SSC infrastructure].

It is suggested to develop a guideline for the use of ICT infrastructure to improve applications in SSC.

Work area	FG-SSC deliverable(s) related to this work area	SDO working on this area	Document number released by this SDO	Corresponding document title	Standardization gap in this area	Future needs and suggestions to SG5
LAN		IEEE 802.3		Popular application standards in LAN		To develop a guideline for the use of ICT infrastructure to build SSC

#### 3.3.4.2 xDSL

There is a Technical Report on ICT infrastructure for SSC which involves telecommunication facilities in FG-SSC [b-FG-SSC infrastructure].

It is suggested to develop a guideline for the use of ICT infrastructure to improve applications in SSC.

Work area	FG-SSC deliverable(s) related to this work area	SDO working on this area	Document number released by this SDO	Corresponding document title	Standardization gap in this area	Future needs and suggestions to SG5
xDSL		ITU-T SG15		G.ref/G.hdsl/G.hs/G.test/G.pl oam/G.dmt/G.lite		To develop guidelines on ICT infrastructure for SSC, including scenarios, use cases etc.
		ITU-T SG15 Q4/15	ITU-T G.991.1	High bit rate digital subscriber line (HDSL) transceivers		
			ITU-T G.991.2	Single-pair high-speed digital subscriber line (SHDSL) transceivers		
			ITU-T G.992.1	Asymmetric digital subscriber line (ADSL) transceivers		
			ITU-T G.992.2	Splitterless asymmetric digital subscriber line (ADSL) transceivers		
			ITU-T G.992.3	Asymmetric digital subscriber line transceivers 2 (ADSL2)		
			ITU-T G.992.4	Splitterless asymmetric digital subscriber line transceivers 2 (splitterless ADSL2)		



Work area	FG-SSC deliverable(s) related to this work area	SDO working on this area	Document number released by this SDO	Corresponding document title	Standardization gap in this area	Future needs and suggestions to SG5
			ITU-T G.992.5	Asymmetric digital subscriber line 2 transceivers (ADSL2)– Extended bandwidth ADSL2 (ADSL2plus)		
			ITU-T G.993.1	Very high speed digital subscriber line transceivers (VDSL)		
			ITU-T G.993.2	Very high speed digital subscriber line transceivers 2 (VDSL2)		
			ITU-T G.993.5	Self-FEXT cancellation (vectoring) for use with VDSL2 transceivers		
			ITU-T G.994.1	Handshake procedures for digital subscriber line transceivers		
			ITU-T G.996.1	Test procedures for digital subscriber line (DSL) transceivers		
			ITU-T G.996.2	Single-ended line testing for digital subscriber lines (DSL)		
			ITU-T G.997.1	Physical layer management for digital subscriber line transceivers		
			ITU-T G.997.2 (draft)	Physical layer management for FAST transceivers		
			ITU-T G.998.1	ATM-based multi-pair bonding		
			ITU-T G.998.2	Ethernet-based multi-pair bonding		
			ITU-T G.998.3	Multi-pair bonding using time-division inverse multiplexing		
			ITU-T G.998.4	Improved impulse noise protection for DSL transceivers		
			ITU-T G.999.1	Interface between the link layer and the physical layer for digital subscriber line (DSL) transceivers		
G.FAST			ITU-T G.9700	Fast access to subscriber terminals (G.fast) - Power spectral density specification		
			ITU-T G.9701	Fast access to subscriber terminals (G.fast) - Physical layer specification		

### 3.3.4.3 EPON/GPON

There is a Technical Report on ICT infrastructure for SSC which involves telecommunication facilities in FG-SSC [b-FG-SSC infrastructure].

It is suggested to develop a guideline for the use of ICT infrastructure to improve applications in SSC.

Work area	FG-SSC deliverable(s) related to this work area	SDO working on this area	Document number released by this SDO	Corresponding document title or summary	Standardization gap in this area	Future needs and suggestions to SG5
EPON		IEEE 802.3ah IEEE 802.3av		IEEE Std 802.3ah-2004, Ethernet in the First Mile. IEEE Std 802.3av-2009, 10 Gb/s PHY for EPON.		To develop a guideline for the use of ICT infrastructure to build SSC
GPON		ITU-T SG15 Q2/15	ITU-T G.984.1	Gigabit-capable passive optical networks (GPON) - General characteristics		
			ITU-T G.984.2	Gigabit-capable Passive Optical Networks (G-PON) - Physical Media Dependent (PMD) layer specification		
			ITU-T G.984.3	Gigabit-capable passive optical networks (G-PON) - Transmission convergence layer specification		
			ITU-T G.984.4	Gigabit-capable passive optical networks (G-PON) - ONT management and control interface specification		
			ITU-T G.984.5	Gigabit-capable passive optical networks (G-PON) - Enhancement band		
			ITU-T G.984.6	Gigabit-capable passive optical networks (GPON) - Reach extension		
			ITU-T G.984.7	Gigabit-capable passive optical networks (GPON) - Long reach		
XGPON		ITU-T SG15 Q2/15	ITU-T G.987	10-Gigabit-capable passive optical network (XG-PON) systems - Definitions, abbreviations and acronyms		
			ITU-T G.987.1	10-Gigabit-capable passive optical networks (XG-PON) - General requirements		
			ITU-T G.987.2	10-Gigabit-capable passive optical networks (XG-PON) - Physical media dependent (PMD) layer specification		
			ITU-T G.987.3	10-Gigabit-capable passive optical networks (XG-PON) - Transmission convergence (TC) layer specification		
			ITU-T G.987.4	10-Gigabit-capable passive optical networks (XG-PON) - Reach extension		
			ITU-T G.988	ONU management and control interface (OMCI) specification		
			ITU-T G.989.1	40-Gigabit-capable passive optical networks (NG-PON2) - General requirements		

Work area	FG-SSC deliverable(s) related to this work area	SDO working on this area	Document number released by this SDO	Corresponding document title or summary	Standardization gap in this area	Future needs and suggestions to SG5
			ITU-T G.989.2	40-Gigabit-capable passive optical networks 2 (NG-PON2) - Physical media dependent (PMD) layer		

#### 3.3.4.4 SDH/MSTP/WDM

There is a Technical Report on ICT infrastructure for SSC which involves telecommunication facilities in FG-SSC [b-FG-SSC infrastructure].

It is suggested to develop a guideline for the use of ICT infrastructure to improve applications in SSC.

Work area	FG-SSC deliverable(s) related to this work area	SDO working on this area	Document number released by this SDO	Corresponding document title	Standardization gap in this area	Future needs and suggestions to SG5
SDH/MSTP/WDM		ITU-T SG15	ITU-T G.680	Physical transfer functions of optical network elements		To develop a guideline for the use of ICT infrastructure to build SSC
			ITU-T G.691	Optical interfaces for single channel STM-64 and other SDH systems with optical amplifiers		
			ITU-T G.692	Optical interfaces for multi-channel systems with optical amplifiers		
			ITU-T G.693	Optical interfaces for intra-office systems		
			ITU-T G.694.1	Spectral grids for WDM applications - DWDM frequency grid		
			ITU-T G.694.2	Spectral grids for WDM applications - CWDM wavelength grid		
			ITU-T G.695	Optical interfaces for coarse wavelength division multiplexing applications		
			ITU-T G.696.1	Longitudinally compatible intra-domain DWDM applications		
			ITU-T G.697	Optical monitoring for dense wavelength division multiplexing systems		
			ITU-T G.698.1	Multichannel DWDM applications with single-channel optical interfaces		
			ITU-T G.698.2	Amplified multichannel dense wavelength division multiplexing applications with single channel optical interfaces		

Work area	FG-SSC deliverable(s) related to this work area	SDO working on this area	Document number released by this SDO	Corresponding document title	Standardization gap in this area	Future needs and suggestions to SG5
			ITU-T G.698.3	Multichannel seeded DWDM applications with single-channel optical interfaces		
			ITU-T G.707/Y.132 2	Network node interface for the synchronous digital hierarchy (SDH)		
			ITU-T G.708	Sub STM-0 network node interface for the synchronous digital hierarchy (SDH)		
			ITU-T G.709/Y.133 1	Interfaces for the optical transport network		
			ITU-T G.774	Synchronous digital hierarchy (SDH) – Management information model for the network element view		
			ITU-T G.774.1	Synchronous digital hierarchy (SDH) – Bidirectional performance monitoring for the network element view		
			ITU-T G.774.2	Synchronous digital hierarchy (SDH) – Configuration of the payload structure for the network element view		
			ITU-T G.774.3	Synchronous digital hierarchy (SDH) – Management of multiplex-section protection for the network element view		
			ITU-T G.774.4	Synchronous digital hierarchy (SDH) – Management of the subnetwork connection protection for the network element view		
			ITU-T G.774.5	Synchronous digital hierarchy (SDH) – Management of connection supervision functionality (HCS/LCS) for the network element view		
			ITU-T G.774.6	Synchronous digital hierarchy (SDH) – Unidirectional performance monitoring for the network element view		
			ITU-T G.774.7	Synchronous digital hierarchy (SDH) – Management of lower order path trace and interface labelling for the network element view		
			ITU-T G.774.8	Synchronous digital hierarchy (SDH) – Management of radio-relay systems for the network element view		
			ITU-T G.774.9	Synchronous digital hierarchy (SDH) – Configuration of linear multiplex-section protection for the network element view		

Work area	FG-SSC deliverable(s) related to this work area	SDO working on this area	Document number released by this SDO	Corresponding document title	Standardization gap in this area	Future needs and suggestions to SG5
			ITU-T G.774.10	Synchronous digital hierarchy (SDH) – Multiplex Section (MS) shared protection ring management for the network element view		
			ITU-T G.775	Loss of Signal (LOS), Alarm Indication Signal (AIS) and Remote Defect Indication (RDI) defect detection		
			ITU-T G.780/Y.135 1	Terms and definitions for synchronous digital hierarchy (SDH) networks		
			ITU-T G.781	Synchronization layer functions		
			ITU-T G.783	Characteristics of synchronous digital hierarchy (SDH) equipment functional blocks		
			ITU-T G.784	Management aspects of synchronous digital hierarchy (SDH) transport network elements		
			ITU-T G.785	Characteristics of a flexible multiplexer in a synchronous digital hierarchy environment		
			ITU-T G.803	Architecture of transport networks based on the synchronous digital hierarchy (SDH)		
			ITU-T G.810	Definitions and terminology for synchronization networks		
			ITU-T G.811	Timing characteristics of primary reference clocks		
			ITU-T G.812	Timing requirements of slave clocks suitable for use as node clocks in synchronization networks		
			ITU-T G.813	Timing characteristics of SDH equipment slave clocks (SEC)		
			ITU-T G.825	The control of jitter and wander within digital networks which are based on the synchronous digital hierarchy (SDH)		
			ITU-T G.826	End-to-end error performance parameters and objectives for international, constant bit-rate digital paths and connections		
			ITU-T G.827	Availability performance parameters and objectives for end-to-end international constant bit-rate digital paths		
			ITU-T G.828	Error performance parameters and objectives for international, constant bit-rate synchronous digital paths		

Work area	FG-SSC deliverable(s) related to this work area	SDO working on this area	Document number released by this SDO	Corresponding document title	Standardization gap in this area	Future needs and suggestions to SG5
			ITU-T G.829	Error performance events for SDH multiplex and regenerator sections		
			ITU-T G.831	Management capabilities of transport networks based on the synchronous digital hierarchy (SDH)		
			ITU-T G.841	Types and characteristics of SDH network protection architectures		
			ITU-T G.842	Interworking of SDH network protection architectures		

### 3.3.4.5 GSM/WCDMA/CDMA

There is a Technical Report on ICT infrastructure for SSC which involves telecommunication facilities in FG-SSC [b-FG-SSC infrastructure].

It is suggested to develop a guideline for the use of ICT infrastructure to improve applications in SSC.

Work area	FG-SSC deliverable(s) related to this work area	SDO working on this area	Document number released by this SDO	Corresponding document title	Standardization gap in this area	Future needs and suggestions to SG5
GSM and WCDMA		3GPP				To develop guidelines on using wireless telecommunication in building SSC, including deployment, application etc.
CDMA		3GPP2				

### 3.3.4.6 LTE TDD/FDD

There is a Technical Report on ICT infrastructure for SSC which involves telecommunication facilities in FG-SSC [b-FG-SSC infrastructure].

It is suggested to develop a guideline for the use of ICT infrastructure to improve applications in SSC.

Work area	FG-SSC deliverable(s) related to this work area	SDO working on this area	Document number released by this SDO	Corresponding document title	Standardization gap in this area	Future needs and suggestions to SG5
LTE TDD/FDD		3GPP				To develop guidelines on using wireless telecommunication in building SSC, including deployment, application etc.



### 3.3.4.7 EMF

There is a Technical Report on EMF consideration in SSC which involves regulations, deployment, public awareness of EMF etc. in FG-SSC [ITU-T TR EMF con].

Work area	FG-SSC deliverable(s) related to this work area	SDO working on this area	Document number released by this SDO	Corresponding document title	Standardization gap in this area	Future needs and suggestions to SG5
EMF	EMF consideration in SSC [ITU-T TR EMF con]	ITU-T SG5, WP2/5 (Electromagnetic fields: emission, immunity and human exposure)	ITU-T K.52	Guidance on complying with limits for human exposure to electromagnetic fields		
			ITU-T K.61	Guidance to measurement and numerical prediction of electromagnetic fields for compliance with human exposure limits for telecommunication installation		
			ITU-T K.70	Mitigation techniques to limit human exposure to EMF's within vicinity of radiocommunication stations		
			ITU-T K.90	Evaluation techniques and working procedures for compliance with limits to power-frequency (DC, 50 Hz, and 60 Hz), electromagnetic field exposure of network operator personnel		
			ITU-T K.91	Guidance for assessment, evaluation and monitoring of the human exposure to radio frequency electromagnetic fields		
			ITU-T K.83	Monitoring of the electromagnetic field levels		
			ITU-T K.100	Measurement of human exposure levels when a wireless installation is put into service		
EMF		ITU-R SG6 (Broadcasting service)	ITU-R BS.1698	Evaluation fields from terrestrial broadcasting transmitting systems operating in any frequency band for assessing exposure to non-ionizing radiation		

### 3.3.5 Data layer standards

#### 3.3.5.1 Cloud computing

There is a Technical Report on ICT infrastructure for SSC which involves data centres and their facilities in FG-SSC [b-FG-SSC infrastructure].

It is suggested to develop a guideline for the use of ICT infrastructure to improve applications in SSC.

Work area	FG-SSC deliverable(s) related to this work area	SDO working on this area	Document number released by this SDO	Corresponding document title	Standardization gap in this area	Future needs and suggestions to SG5
Cloud computing		DMTF				To develop guidelines for data centres, including scenarios, use cases, best practice, and security etc
		ITU-T SG13	ITU-T Y.3501			
			ITU-T Y.3510			
			ITU-T Y.3511			
			ITU-T Y.3520			
		ITU-T SG17	ITU-T X.1601rev	Cloud computing security framework		
Open data	Anonymization infrastructure and open data for SSC [b-FG-SSC data]					To develop Recommendations for the future needs of big data, open data and anonymization infrastructure etc, supporting various SSC services

### 3.3.6 Application and support layer standards

#### 3.3.6.1 SOA

Work area	FG-SSC deliverable(s) related to this work area	SDO working on this area	Document number released by this SDO	Corresponding document title	Standardization gap in this area	Future needs and suggestions to SG5
SOA		ISO/IEC JTC 1/SC 38 (Cloud Computing and Distributed Platforms)	ISO/IEC DIS 18384-1	Information technology – Reference Architecture for Service Oriented Architecture (SOA RA) – Part 1: Terminology and Concepts for SOA		
			ISO/IEC DIS 18384-2	Information Technology - Reference Architecture for Service Oriented Architecture (SOA RA) – Part 2: Reference Architecture for SOA Solutions		

Work area	FG-SSC deliverable(s) related to this work area	SDO working on this area	Document number released by this SDO	Corresponding document title	Standardization gap in this area	Future needs and suggestions to SG5
			ISO/IEC DIS 18384-3	Distributed Application Platforms and Services (DAPS) – Reference Architecture for Service Oriented Architecture (SOA) – Part 3: Service Oriented Architecture Ontology		

### 3.3.6.2 Information presence

It is suggested to develop guidelines on city simulation to help citizens understand the vision of SSC.

Work area	FG-SSC deliverable(s) related to this work area	SDO working on this area	Document number released by this SDO	Corresponding document title	Standardization gap in this area	Future needs and suggestions to SG5
Information presence	Integrated management for SSC [ITU-T TR management]					To develop guidelines for 3D virtual reality of SSC, city simulation, web services for SSC, including scenarios, use cases, best practice, and security etc

### 3.3.6.3 Decision making

There is a technical report on decision making and integrated management in SSC [ITU-T TR management].

It is suggested to develop guidelines for decision making in SSC.

Work area	FG-SSC deliverable(s) related to this work area	SDO working on this area	Document number released by this SDO	Corresponding document title	Standardization gap in this area	Future needs and suggestions to SG5
Decision making	Integrated management for SSC [ITU-T TR management]					To develop guidelines for decision making in a city, including scenarios, use cases, and best practice

### 3.4 SSC management and assessment standards

#### 3.4.1 Systemic planning and partnership building

##### 3.4.1.1 Urban planning

Work area	FG-SSC deliverable(s) related to this work area	SDO working on this area	Document number released by this SDO	Corresponding document title	Standardization gap in this area	Future needs and suggestions to SG5
Urban planning	SSC: a guide for city leaders [b-FG-SSC guide]					To develop guidelines for urban planning.

##### 3.4.1.2 Budget analysis

Work area	FG-SSC deliverable(s) related to this work area	SDO working on this area	Document number released by this SDO	Corresponding document title	Standardization gap in this area	Future needs and suggestions to SG5
Budget analysis	SSC: a guide for city leaders [b-FG-SSC guide]					

#### 3.4.2 Deployment and implementation

##### 3.4.2.1 Engineering construction

Work area	FG-SSC deliverable(s) related to this work area	SDO working on this area	Document number released by this SDO	Corresponding document title	Standardization gap in this area	Future needs and suggestions to SG5
engineering construction	SSC: a guide for city leaders [b-FG-SSC guide]	ISO/TC 176 (Quality management and quality assurance)	ISO 18091:2014	Quality management systems – Guidelines for the application of ISO 9001:2008 in local government		To develop guidelines for building SSC.

##### 3.4.2.2 Engineering supervision

Work area	FG-SSC deliverable(s) related to this work area	SDO working on this area	Document number released by this SDO	Corresponding document title	Standardization gap in this area	Future needs and suggestions to SG5
To develop guidelines for urban planning.	SSC: a guide for city leaders [b-FG-SSC guide] overview of key performance indicators in smart sustainable cities [ITU-T L.KPIs-overview]	ISO/TC 176 (Quality management and quality assurance)	ISO 18091:2014	Quality management systems – Guidelines for the application of ISO 9001:2008 in local government		To develop guideline for evaluating the progress of building SSC.

### 3.4.3 Management and administration

#### 3.4.3.1 Operation and maintenance

Work area	FG-SSC deliverable(s) related to this work area	SDO working on this area	Document number released by this SDO	Corresponding document title	Standardization gap in this area	Future needs and suggestions to SG5
Operation and maintenance	SSC: a guide for city leaders [b-FG-SSC guide]	ISO/TC 176 (Quality management and quality assurance)	ISO 18091:2014	Quality management systems – Guidelines for the application of ISO 9001:2008 in local government		

#### 3.4.3.2 Business operation

Work area	FG-SSC deliverable(s) related to this work area	SDO working on this area	Document number released by this SDO	Corresponding document title	Standardization gap in this area	Future needs and suggestions to SG5
Business operation	SSC: a guide for city leaders [b-FG-SSC guide]	DMTF (Distributed Management Task Force)				

### 3.4.4 Resilience and disaster recovery

There are several Technical Reports on service continuity, city resilience and disaster recovery in SSC [ITU-T TR overview] [ITU-T TR management] [ITU-T TR security].

It is suggested to develop guidelines for service continuity, city resilience, disaster recovery and emergency response in SSC.

Work area	FG-SSC deliverable(s) related to this work area	SDO working on this area	Document number released by this SDO	Corresponding document title	Standardization gap in this area	Future needs and suggestions to SG5
Resilience and disaster recovery	Integrated management for SSC [ITU-T TR management]	ITU-T FG DR&NRR (Focus Group on Disaster Relief Systems, Network Resilience and Recovery)		Technical Report on Telecommunications and Disaster Mitigation		To develop guidelines for service continuity, city resilience, disaster recovery and emergency response in SSC, including service model, scenarios, best practice
				Technical Report: Overview of Disaster Relief Systems, Network Resilience and Recovery		
				Technical Report: Promising technologies and use cases		

Work area	FG-SSC deliverable(s) related to this work area	SDO working on this area	Document number released by this SDO	Corresponding document title	Standardization gap in this area	Future needs and suggestions to SG5
				Technical Report: Gap Analysis of Disaster Relief Systems, Network Resilience and Recovery		
				Technical Report: Terms and definitions for disaster relief systems, network resilience and recovery		
				Technical Report: Requirements for Disaster Relief System		
				Technical Report: Requirements for network resilience and recovery		
				Technical Report: Requirements on the improvement of network resilience and recovery with movable and deployable ICT resource units		
		ITU-T SG2	E.RDR-MMS	Requirement for Disaster Relief Mobile Message Service		
			E.TD-DR	Terms and definitions for DR&NRR		
			E.RDR	Requirements for Disaster Relief Systems		
			E.RDR-SCBM	Requirements for Safety Confirmation and Broadcast Message Service for Disaster Relief		
Alert delivery		ITU-T SG16	ITU-T H.785.0	Digital signage: Requirements of disaster information services		
			ITU-T H.DS-CASF	Digital signage: Common alerting service framework		
		ITU-T SG17	ITU-T X.1303	Common Alerting Protocol v1.1 (CAP1.1)		
			ITU-T X.1303-bis	Common Alerting Protocol v1.2 (CAP1.2)		

### 3.4.5 Evaluation and assessment

#### 3.4.5.1 Methodology of testing

FG-SSC developed a series of Technical Specifications on KPIs for SSC [ITU-T L, KPIs-overview] [ITU-T L.KPIs-ICT] [ITU-T L.KPIs-impact].

It is suggested to develop guidelines for testing city systems, including use cases, best practice etc.



Work area	FG-SSC deliverable(s) related to this work area	SDO working on this area	Document number released by this SDO	Corresponding document title	Standardization gap in this area	Future needs and suggestions to SG5
Testing of city systems	KPIs for SSC [ITU-T L,KPIs-overview] [ITU-T L.KPIs-ICT] [ITU-T L.KPIs-impact]	ITU-T SG5 (Environment and climate change)				To develop guidelines for testing city systems, including use cases, best practice etc.

### 3.4.5.2 Methodology of assessment

FG-SSC developed a series of Technical Specifications on KPIs for SSC [ITU-T L,KPIs-overview] [ITU-T L.KPIs-ICT] [ITU-T L.KPIs-impact].

It is suggested to develop guidelines for evaluating the process of building SSC, including use cases, best practice etc.

Work area	FG-SSC deliverable(s) related to this work area	SDO working on this area	Document number released by this SDO	Corresponding document title	Standardization gap in this area	Future needs and suggestions to SG5
Evaluating SSC	KPIs for SSC [ITU-T L,KPIs-overview] [ITU-T L.KPIs-ICT] [ITU-T L.KPIs-impact]	ITU-T SG5 (Environment and climate change)				To develop guidelines for evaluating the process of building SSC, including use cases, best practice etc.

## 3.5 Building and physical infrastructure standards

### 3.5.1 Urban planning

Work area	FG-SSC deliverable(s) related to this work area	SDO working on this area	Document number released by this SDO	Corresponding document title	Standardization gap in this area	Future needs and suggestions to SG5
Urban planning	SSC: a guide for city leaders [b-FG-SSC guide]	ISO/TC 268/WG 2	ISO 37120:2014	Sustainable development of communities – Indicators for city services and quality of life		

### 3.5.2 Low carbon design and construction

Work area	FG-SSC deliverable(s) related to this work area	SDO working on this area	Document number released by this SDO	Corresponding document title	Standardization gap in this area	Future needs and suggestions to SG5
Low carbon design and construction		ISO/TC 207/SC 7	ISO/TS 14067:2013	Carbon footprint of products		

Work area	FG-SSC deliverable(s) related to this work area	SDO working on this area	Document number released by this SDO	Corresponding document title	Standardization gap in this area	Future needs and suggestions to SG5
Greenhouse gases			ISO 14064-1:2006	Greenhouse gases – Part 1: Specification with guidance at the organization level for quantification and reporting of greenhouse gas emissions and removals		
			ISO 14064-2:2006	Greenhouse gases – Part 2: Specification with guidance at the project level for quantification, monitoring and reporting of greenhouse gas emission reductions or removal enhancements		
			ISO 14064-3:2006	Greenhouse gases – Part 3: Specification with guidance for the validation and verification of greenhouse gas assertions		

### 3.5.3 Building systems

Work area	FG-SSC deliverable(s) related to this work area	SDO working on this area	Document number released by this SDO	Corresponding document title	Standardization gap in this area	Future needs and suggestions to SG5
Building environment design	Smart sustainable buildings for SSC [b-FG-SSC building]	ISO/TC205 WG1: General principles WG2: Design of energy-efficient buildings WG3: Building Automation and Control System (BACS) Design WG5: Indoor thermal environment WG7: Indoor visual environment WG8: Radiant heating and cooling systems WG9: Heating and cooling systems WG10: Commissioning				To develop guidelines for smart buildings, including use cases and best practice etc.
Energy performance of buildings		ISO/TC 163/WG 4: Joint between ISO/TC 163 and ISO/TC 205: Energy performance of buildings using holistic approach				

### 3.5.4 Building information modeling (BIM)

Work area	FG-SSC deliverable(s) related to this work area	SDO working on this area	Document number released by this SDO	Corresponding document title	Standardization gap in this area	Future needs and suggestions to SG5
Building information modeling		International Alliance for Interoperability: Industry Foundation Class				To develop guidelines for smart buildings, including use cases and best practice etc.
		ISO/TC 184 (Automation systems and integration)	ISO 16739:2013	Industry Foundation Classes (IFC) for data sharing in the construction and facility management industries (IFC)		
			ISO 29481-1	Building information modeling - Information delivery manual - Part 1: Methodology and format (IDM)		
			ISO 29481-2	Building information modeling - Information delivery manual - Part 2: Interaction Framework (IDM)		
			ISO 12006-3	Building construction - Organization of information about construction works - Part 3: Framework for object-oriented information (IFD)		

### 3.5.5 Traffic systems

Work area	FG-SSC deliverable(s) related to this work area	SDO working on this area	Document number released by this SDO	Corresponding document title	Standardization gap in this area	Future needs and suggestions to SG5
Road traffic		ISO/TC 241 (Road traffic safety management systems)	ISO 39001:2012	Road traffic safety (RTS) management systems - Requirements with guidance for use		
Road vehicles		ISO/TC 22 (Road vehicles)				

### 3.5.6 Urban pipeline network

Work area	FG-SSC deliverable(s) related to this work area	SDO working on this area	Document number released by this SDO	Corresponding document title	Standardization gap in this area	Future needs and suggestions to SG5
pipeline	Multi-service infrastructure for SSC in new-development areas [b-FG-SSC pipeline]	ISO/TC 67/SC 2 ( Pipeline transportation systems)	ISO 3183:2012	Petroleum and natural gas industries – Steel pipe for pipeline transportation systems		To develop Recommendations on the management of city infrastructure
			ISO 12490:2011	Petroleum and natural gas industries – Mechanical integrity and sizing of actuators and mounting kits for pipeline valves		
			ISO 12736:2014	Petroleum and natural gas industries – Wet thermal insulation coatings for pipelines, flow lines, equipment and subsea structures		
			ISO/TS 12747:2011	Petroleum and natural gas industries – Pipeline transportation systems – Recommended practice for pipeline life extension		
			ISO 13623:2009	Petroleum and natural gas industries – Pipeline transportation systems		
			ISO/NP 13623	Petroleum and natural gas industries – Pipeline transportation systems		
			ISO 13847:2013	Petroleum and natural gas industries – Pipeline transportation systems – Welding of pipelines		
			ISO/DIS 14313	Petroleum and natural gas industries – Pipeline transportation systems – Pipeline valves		
			ISO 14313:2007	Petroleum and natural gas industries – Pipeline transportation systems – Pipeline valves (including Cor.1)		
			ISO 14723:2009	Petroleum and natural gas industries – Pipeline transportation systems – Subsea pipeline valves		

Work area	FG-SSC deliverable(s) related to this work area	SDO working on this area	Document number released by this SDO	Corresponding document title	Standardization gap in this area	Future needs and suggestions to SG5
			ISO 15589-1:2015	Petroleum, petrochemical and natural gas industries – Cathodic protection of pipeline systems – Part 1: On-land pipelines		
			ISO 15589-2:2012	Petroleum, petrochemical and natural gas industries – Cathodic protection of pipeline transportation systems – Part 2: Offshore pipelines		
			ISO 15590-1:2009	Petroleum and natural gas industries – Induction bends, fittings and flanges for pipeline transportation systems – Part 1: Induction bends		
			ISO 15590-2:2003	Petroleum and natural gas industries – Induction bends, fittings and flanges for pipeline transportation systems – Part 2: Fittings		
			ISO/NP 15590-2	Petroleum and natural gas industries – Induction bends, fittings and flanges for pipeline transportation systems – Part 2: Fittings		
			ISO 15590-3:2004	Petroleum and natural gas industries – Induction bends, fittings and flanges for pipeline transportation systems – Part 3: Flanges		
			ISO/NP 15590-3	Petroleum and natural gas industries – Induction bends, fittings and flanges for pipeline transportation systems – Part 3: Flanges		
			ISO/DIS 16440	Petroleum and natural gas industries – Pipeline transportation systems – Design, construction and maintenance of steel cased pipelines		
			ISO/NP 16441	Petroleum and Natural Gas Industries - Pipeline transportation systems - Actuation mechanical integrity and sizing for subsea pipeline valves		

Work area	FG-SSC deliverable(s) related to this work area	SDO working on this area	Document number released by this SDO	Corresponding document title	Standardization gap in this area	Future needs and suggestions to SG5
			ISO 16708:2006	Petroleum and natural gas industries – Pipeline transportation systems – Reliability-based limit state methods		
			ISO/AWI 19345-1	PNGI – Pipeline integrity management specification – Part 1: Full-life cycle integrity management for onshore pipeline		
			ISO/AWI 19345-2	PNGI – Pipeline integrity management specification – Part 2: Full-life cycle integrity management for offshore pipeline		
			ISO/AWI 19561	Petroleum and natural gas industries – Field pressure testing for Gas and Liquid Petroleum Pipelines		
			ISO/AWI 20074	Petroleum and natural gas industries – Geological hazards risk management of oil and gas pipelines		
			ISO 21329:2004	Petroleum and natural gas industries – Pipeline transportation systems – Test procedures for mechanical connectors		
			ISO 21809-1:2011	Petroleum and natural gas industries – External coatings for buried or submerged pipelines used in pipeline transportation systems – Part 1: Polyolefin coatings (3-layer PE and 3-layer PP)		
			ISO/AWI 21809-1	Petroleum and natural gas industries – External coatings for buried or submerged pipelines used in pipeline transportation systems – Part 1: Polyolefin coatings (3-layer PE and 3-layer PP)		
			ISO 21809-2:2014	Petroleum and natural gas industries – External coatings for buried or submerged pipelines used in pipeline transportation systems – Part 2: Single layer fusion-bonded epoxy coatings		



Work area	FG-SSC deliverable(s) related to this work area	SDO working on this area	Document number released by this SDO	Corresponding document title	Standardization gap in this area	Future needs and suggestions to SG5
			ISO 21809-3:2008	Petroleum and natural gas industries – External coatings for buried or submerged pipelines used in pipeline transportation systems – Part 3: Field joint coatings		
			ISO/DIS 21809-3	Petroleum and natural gas industries – External coatings for buried or submerged pipelines used in pipeline transportation systems – Part 3: Field joint coatings, including Amd.1 (2011)		
			ISO 21809-4:2009	Petroleum and natural gas industries – External coatings for buried or submerged pipelines used in pipeline transportation systems – Part 4: Polyethylene coatings (2-layer PE)		
			ISO/NP 21809-5	Petroleum and natural gas industries – External coatings for buried or submerged pipelines used in pipeline transportation systems – Part 5: External concrete coatings		
			ISO 21809-5:2010	Petroleum and natural gas industries – External coatings for buried or submerged pipelines used in pipeline transportation systems – Part 5: External concrete coatings		
			ISO/NP 21809-6	Petroleum and natural gas industries – External coatings for buried or submerged pipelines used in pipeline transportation systems – Part 6: Multilayer fusion-bonded epoxy coatings (FBE)		
			ISO/AWI 21809-11	Petroleum and natural gas industries – External coatings for buried or submerged pipelines used in pipeline transportation systems – Part 11: Coating repairs on rehabilitation		

## 4 Relevant SDOs and their work on SSC

### ANSI

#### Summary

Full name of (standards) body/group	American National Standards Institute
Membership	community of vendors, operators, manufacturers, service providers, academia
Website	<a href="http://www.ansi.org/">http://www.ansi.org/</a>

#### Activities and documents

Full name of TC	
Full name of SC/WG	
Chairman/Contact	
Website full description	
Summary of activities	On April 4th, 2013, ANSI organized a joint forum to discuss role of standards and certification in international and national Smart City development
Comments	

#### Last updated

4 April 2013

### BSI

#### Summary

Full name of (standards) body/group	British Standards Institution
Membership	community of vendors, operators, manufacturers, service providers, academia
Website	<a href="http://www.bsigroup.com/en-GB/">http://www.bsigroup.com/en-GB/</a>

## Activities and documents

Full name of TC	Smart Cities Advisory Group
Full name of SC/WG	
Chairman/Contact	
Website full description	
Summary of activities	<p>BSI's Smart Cities Advisory Group identified a number of issues where barriers to smart city implementation can be reduced and progress accelerated through provision of standards. The benefits of this approach will include sharing of good practice on development and implementation of new service models, identifying common solutions to technical problems, setting out the preconditions for interoperability of data and city systems and describing ways in which risks can be managed and mitigated.</p> <p>BSI's smart cities standards work provides a foundation of knowledge to help establish a common vision for smart cities. The first stage of work has focused on establishing a common understanding of the benefits of smart cities and the approaches that can be taken to improve city performance. Specific projects include:</p> <ul style="list-style-type: none"> <li>▪ Providing an overview description of a smart city to provide a basis for communicating the benefits of smart cities to key decision makers (PD 8100 – published and available online for free)</li> <li>▪ Establishing common terminology for smart cities, promoting a shared understanding of concepts (PAS 180 – published and available online for free)</li> <li>▪ Preparing smart city planning guidelines to set out how major new residential, retail and business developments can support the wider plans of that city to become smarter (PD 8101 – published and available online for free)</li> <li>▪ Setting out principles for economic assessment and funding of smart city initiatives, covering the potential business models and means of procurement (Report available for free at <a href="http://www.bsigroup.com/smart-cities/smart-cities-economic-assessment-and-funding-initiatives/">www.bsigroup.com/smart-cities/smart-cities-economic-assessment-and-funding-initiatives/</a>)</li> <li>▪ Providing a decision-making framework for smart city leaders, setting out how to deliver a smart city project (PAS 181 – published and available online for free)</li> <li>▪ Developing a smart city data concept model to promote the sharing of data between different agencies within a city (PAS 182 – published and available online for free)</li> <li>▪ Mapping the current smart city landscape across different standards bodies internationally and sharing best practice (Free report at <a href="http://www.bsigroup.com/smartcitymapping">www.bsigroup.com/smartcitymapping</a>)</li> <li>▪ Contributing to ISO standards on sustainable community development, global city indicators and infrastructure metrics</li> </ul> <p>In the second phase of work, starting in 2015, BSI is collaborating with the Future Cities Catapult to create the City Standards Institute (CSI). CSI is currently identifying further issues that should form the basis of a more detailed standards programme beyond 2015, addressing specific practical issues and risks that will be encountered in the roll-out of smart city programmes. Specific projects that are being considered include:</p> <ul style="list-style-type: none"> <li>▪ Identifying a set of core datasets for cities, their applications and benefits</li> <li>▪ Developing a decision making framework for sharing data and information</li> </ul>

- Establishing good procurement processes, and providing guidance on business models and business case development in smart cities
- Focusing on use-cases that provide practical applications of smart-city technology, such as street lighting, smart parking systems and smart refuse collection
- Providing guidance on ways to harness citizen engagement in smart city initiatives and ensure digital inclusivity

The UK good practice created through BSI's work will be offered for adoption internationally through CEN/CENELEC, ISO and IEC as deemed appropriate. BSI will take a leading role in European and international standards activities, actively working to align programmes across standards bodies, building on existing knowledge and sharing UK initiatives with other countries to create a global framework for smart cities knowledge. For more details please visit [www.bsigroup.com/smartcities](http://www.bsigroup.com/smartcities)

## Comments

### Last updated

24 April 2015

## CCSA

### Summary

Full name of (standards) body/group	<b>China Communications Standards Association</b>
Membership	community of vendors, operators, academia
Website	<a href="http://www.ccsa.org.cn/">http://www.ccsa.org.cn/</a>

## Activities and documents

### CCSA/TC 10

Full name of TC	Technical Committee on Ubiquitous Network
Full name of SC/WG	
Chairman/Contact	Ms. Duo Liu
Website full description	<a href="http://www.ccsa.org.cn/tc/index.php?tcid=tc10">http://www.ccsa.org.cn/tc/index.php?tcid=tc10</a>
Summary of activities	TC10 began to develop smart city's standards since February 2012 , there are now work items on smart city standards, ie overall framework, terms and definitions, assessment methods and indicators, cross-platform information exchange, information platform, security needs.
Comments	Only Chinese description provided

Name	Title	status	Type	Date	Hyperlink
Terms	Terminologies and Definitions of Smart City	Under development	Standard	2015	
Framework	High Level Framework and Technical Requirements of Smart City	Published	Standard	March 2013	
Evaluation	Study on Evaluation Index System and Evaluation Method of Smart City	Published	Technical Report	July 2012	
Platform	Technology Architecture and Functional Requirements for Public Support Platform of Smart City	Under development	Technical Report	2015	
Information exchange	Technical Requirements of Cross-platform Information Exchange of Smart City	Published	Standard	2014	
Security	Security Requirements of Smart City	Published	Technical Report	2014	
Standardization	Guideline on Standardization Activities of Smart City	Under development	Standard	2015	
	Standard framework of Smart City	Under development	Technical Report	2015	
	Service requirements on information sharing of Smart City	Under development	Standard	2015	
	Study on information sharing of Smart City	Under development	Technical Report	2015	
	Requirements and technologies on Open data of Smart City	Under development	Technical Report	2015	
	Study on Construction, Operations and Services of Smart City	Under development	Technical Report	2015	

**Last updated**

10 April 2015

**CEN/CENELEC/ETSI****Summary**

Full name of (standards) body/group	Comité Européen de Normalisation (French) / European Committee for Electro technical Standardization
Membership	community of vendors, operators, manufacturers, service providers, academia
Website	<a href="http://www.cenelec.eu/Pages/default.aspx">http://www.cenelec.eu/Pages/default.aspx</a>

**Activities and documents****SSCC-CG**

Full name of TC	Sustainable Smart Cities and Communities Coordination Group
Full name of SC/WG	
Chairman/Contact	
Website full description	
Summary of activities	The “Smart and Sustainable Cities and Communities Coordination Group” (SSCC-CG - AFNOR Secretariat) was created by CEN/BT (Decision BT 32/2012) and CENELEC/BT (Decision D143/067-069) in 2012. Following a request from ETSI, at the 82nd CEN/CENELEC/ETSI Joint Presidents' Group on 2013-11-13, the JPG agreed to have a SSCC-CG common to the three ESOs. SSCC-CG finalized a “10 pages summary of the SSCC-CG final report to CEN and CENELEC Technical Boards and ETSI Board”, and a “SSCC-CG final report”.
Comments	

**Last updated**

24 April 2015

**DIN/DKE****Summary**

Full name of (standards) body/group	Deutsches Institut für Normung e.V. / Deutsche Kommission Elektrotechnik
Membership	community of vendors, operators, manufacturers, service providers, academia
Website	<a href="http://www.dke.de/de/Seiten/Startseite.aspx">http://www.dke.de/de/Seiten/Startseite.aspx</a>



## Activities and documents

Full name of TC	
Full name of SC/WG	
Chairman/Contact	
Website full description	
Summary of activities	DIN and DKE developed the "smart city in Germany Standardization Roadmap" in May 2013
Comments	

### Last updated

May 2013

## ETNO

### Summary

Full name of (standards) body/group	European Telecommunications Network Operators' Association (ETNO)
Membership	community of operators
Website	<a href="http://www.etno.be/">http://www.etno.be/</a>

## Activities and documents

### WG Corporate Responsibility

Full name of TC	
Full name of SC/WG	WG Corporate Responsibility
Chairman/Contact	Danilo Riva
Website full description	<a href="https://www.etno.eu/home/working-groups/corporate-responsibility">https://www.etno.eu/home/working-groups/corporate-responsibility</a>
Summary of activities	Sustainable development is a global strategic goal, which seeks to achieve economic growth that promotes a fair and just society while conserving the natural environment and the world's scarce, non-renewable resources for future generations.
Comments	

### Last updated

22 July 2013

## ETSI

### Summary

Full name of (standards) body/group	<b>European Telecommunications Standards Institute</b>
Membership	community of vendors, operators, academia
Website	<a href="http://www.etsi.org/">http://www.etsi.org/</a>

### Activities and documents

#### 1. ETSI/TC ATTM

Full name of TC	Access, Terminals, Transmission and Multiplexing
Full name of SC/WG	
Chairman/Contact	Roche Dominique
Website full description	<a href="http://portal.etsi.org/portal/server.pt/community/ATTM/297">http://portal.etsi.org/portal/server.pt/community/ATTM/297</a>
Summary of activities	A series of Plug tests with the Fixed Services and Networks Alliance on Gigabit Passive Optical Networks (GPON)
Comments	

Name	Title	status	Type	Date	Hyperlink
TS 105 series	Broadband Deployment & Energy Efficiency		Technical Specification		
ES 205 series	Energy management; Global KPIs: Monitoring of sustainability		ETSI Standard		

#### 2. ETSI/TC CLOUD

Full name of TC	Cloud
Full name of SC/WG	
Chairman/Contact	Mr.Fisher Michael
Website full description	<a href="http://portal.etsi.org/portal/server.pt/community/CLOUD/310">http://portal.etsi.org/portal/server.pt/community/CLOUD/310</a>
Summary of activities	The goal of TC CLOUD is to address issues associated with the convergence between IT (Information Technology) and Telecommunications. The focus is on scenarios where connectivity goes beyond the local network. This includes not only Cloud computing but also the emerging commercial trend towards Cloud computing which places particular emphasis on ubiquitous network access to scalable computing and storage resources.
Comments	

No.	Title	status	Type	Date	Hyperlink
TS 103 142	CLOUD; Test Descriptions for Cloud Interoperability	Published	Technical Specification	2013.4	<a href="http://www.etsi.org/deliver/etsi_ts/103100_103199/103142/01.01.01_60/ts_103142v010101p.pdf">http://www.etsi.org/deliver/etsi_ts/103100_103199/103142/01.01.01_60/ts_103142v010101p.pdf</a>
TR 103 125	CLOUD; SLAs for Cloud services	Published	Technical Report	2012.11	<a href="http://www.etsi.org/deliver/etsi_tr/103100_103199/103125/01.01.01_60/tr_103125v010101p.pdf">http://www.etsi.org/deliver/etsi_tr/103100_103199/103125/01.01.01_60/tr_103125v010101p.pdf</a>
TR 103 126	CLOUD; Cloud private-sector user recommendations	Published	Technical Report	2012.11	<a href="http://www.etsi.org/deliver/etsi_tr/103100_103199/103126/01.01.01_60/tr_103126v010101p.pdf">http://www.etsi.org/deliver/etsi_tr/103100_103199/103126/01.01.01_60/tr_103126v010101p.pdf</a>
TR 102 997	CLOUD; Initial analysis of standardization requirements for Cloud services	Published	Technical Report	2010.4	<a href="http://www.etsi.org/deliver/etsi_tr/102900_102999/102997/01.01.01_60/tr_102997v010101p.pdf">http://www.etsi.org/deliver/etsi_tr/102900_102999/102997/01.01.01_60/tr_102997v010101p.pdf</a>
TS 102 811	GRID; Grid Component Model (GCM); Interoperability test specification	Published	Technical Specification	2010.3	<a href="http://www.etsi.org/deliver/etsi_ts/102800_102899/102811/01.01.01_60/ts_102811v010101p.pdf">http://www.etsi.org/deliver/etsi_ts/102800_102899/102811/01.01.01_60/ts_102811v010101p.pdf</a>
TS 102 830	GRID; Grid Component Model (GCM); GCM Fractal Management API	Published	Technical Specification	2010.3	<a href="http://www.etsi.org/deliver/etsi_ts/102800_102899/102830/01.01.01_60/ts_102830v010101p.pdf">http://www.etsi.org/deliver/etsi_ts/102800_102899/102830/01.01.01_60/ts_102830v010101p.pdf</a>
TS 102 828	GRID; Grid Component Model (GCM); GCM Application Description	Published	Technical Specification	2010.3	<a href="http://www.etsi.org/deliver/etsi_ts/102800_102899/102828/02.01.01_60/ts_102828v020101p.pdf">http://www.etsi.org/deliver/etsi_ts/102800_102899/102828/02.01.01_60/ts_102828v020101p.pdf</a>
DTR/CLOUD-0013-GHGmitigation	CLOUD; Cloud as a mitigating technology to reduce emissions in other sectors	Under development	Technical Report	2012.4.16	

### 3. ETSI/TC eHEALTH

Full name of TC	eHEALTH
Full name of SC/WG	
Chairman/Contact	Wood Suno
Website full description	<a href="http://portal.etsi.org/portal/server.pt/community/eHEALTH/304">http://portal.etsi.org/portal/server.pt/community/eHEALTH/304</a>
Summary of activities	Participation in IHE (Integrating the Healthcare Enterprise) CONNECTATHON events with the provision of state-of-the-art TTCN-3 test tools for HN7 profiles
Comments	

Name	Title	status	Type	Date	Hyperlink

#### 4. ETSI/TC ESI

Full name of TC	Electronic Signatures and Infrastructures
Full name of SC/WG	
Chairman/Contact	Genghini Riccardo
Website full description	<a href="http://portal.etsi.org/portal/server.pt/community/ESI/307">http://portal.etsi.org/portal/server.pt/community/ESI/307</a>
Summary of activities	Development of an interoperability portal to facilitate remote interoperability events for standards XAdES, CAAdES, PAdES (Advanced Electronic Signature)
Comments	

Name	Title	status	Type	Date	Hyperlink
DTR/ESI-0019000	Electronic Signatures and Infrastructures (ESI); Rationalised structure for Electronic Signature Standardisation	Under development	Technical Report	2012.5.13	
DTR/ESI-0019100	Electronic Signatures and Infrastructures (ESI); Business Driven Guidance for Signature Creation and Validation	Under development	Technical Report	2012.5.13	
DTS/ESI-0019101	Electronic Signatures and Infrastructures (ESI); Policy and Security Requirements for Electronic Signature Creation and Validation	Under development	Technical Specification	2012.5.13	
DTS/ESI-0019124	Electronic Signatures and Infrastructures (ESI); CAAdES Testing Compliance and Interoperability	Under development	Technical Specification	2012.5.17	
DTS/ESI-0019134	Electronic Signatures and Infrastructures (ESI); XAdES Testing Compliance and Interoperability	Under development	Technical Specification	2012.5.17	

## 5. ETSI/TC ITS

Full name of TC	Intelligent Transport Systems
Full name of SC/WG	
Chairman/Contact	Hess Soeren
Website full description	<a href="http://portal.etsi.org/portal/server.pt/community/ITS/317">http://portal.etsi.org/portal/server.pt/community/ITS/317</a>
Summary of activities	Development of test specifications and test frameworks, as well as interoperability events on Cooperative Mobile Systems and Road Toll Systems/DSRC co-existence.
Comments	

No.	Title	status	Type	Date	Hyperlink
TS 102 708	Intelligent Transport Systems (ITS); RTTT; Test specifications for High Data Rate (HDR) data transmission equipment operating in the 5,8 GHz ISM band	Under development	Technical Specification	2013.3	
TS 102 917	Intelligent Transport Systems (ITS); Test specifications for the channel congestion control algorithms operating in the 5,9 GHz range	Under development	Technical Specification	2013.1	
ES 200 674	Intelligent Transport Systems (ITS); Road Transport and Traffic Telematics (RTTT); Dedicated Short Range Communications (DSRC)	Under development	ETSI Standard	2013.5	
TR 101 607	Intelligent Transport Systems (ITS); Cooperative ITS (C-ITS); Release 1	Published	Technical Report	2013.5	<a href="http://www.etsi.org/deliver/etsi_tr/101600_101699/101607/01.01.01_60/tr_101607v010101p.pdf">http://www.etsi.org/deliver/etsi_tr/101600_101699/101607/01.01.01_60/tr_101607v010101p.pdf</a>
TS 103 097	Intelligent Transport Systems (ITS); Security; Security header and certificate formats	Published	Technical Specification	2013.4	<a href="http://www.etsi.org/deliver/etsi_ts/103000_103099/103097/01.01.01_60/ts_103097v010101p.pdf">http://www.etsi.org/deliver/etsi_ts/103000_103099/103097/01.01.01_60/ts_103097v010101p.pdf</a>
TR 102 965	Intelligent Transport Systems (ITS); Application Object Identifier (ITS-AID); Registration list	Published	Technical Report	2013.3	<a href="http://www.etsi.org/deliver/etsi_tr/102900_102999/102965/01.01.01_60/tr_102965v010101p.pdf">http://www.etsi.org/deliver/etsi_tr/102900_102999/102965/01.01.01_60/tr_102965v010101p.pdf</a>
TR 102 960	Intelligent Transport Systems (ITS); Mitigation techniques to avoid interference between European CEN Dedicated Short Range Communication (RTTT DSRC) equipment and Intelligent Transport Systems (ITS) operating in the 5 GHz frequency range; Evaluation of mitigation methods and techniques	Published	Technical Report	2012.11	<a href="http://www.etsi.org/deliver/etsi_tr/102900_102999/102960/01.01.01_60/tr_102960v010101p.pdf">http://www.etsi.org/deliver/etsi_tr/102900_102999/102960/01.01.01_60/tr_102960v010101p.pdf</a>
TS 102 723	Intelligent Transport Systems (ITS); OSI cross-layer topics	Under development	Technical Specification	2012.11	

No.	Title	status	Type	Date	Hyperlink
TR 103 061	Intelligent Transport Systems (ITS); Testing	Under development	Technical Report	2012.11	

## 6. ETSI/TC M2M

Full name of TC	Machine-to-Machine communications
Full name of SC/WG	
Chairman/Contact	Arndt Marylin
Website full description	<a href="http://portal.etsi.org/portal/server.pt/community/M2M/319">http://portal.etsi.org/portal/server.pt/community/M2M/319</a>
Summary of activities	Interoperability demonstrations
Comments	

No.	Title	status	Type	Date	Hyperlink
TS 102 690	Machine-to-Machine communications (M2M); Functional architecture	Under development	Technical Specification	2011.10.17	
TR 102 732	Machine-to-Machine Communications (M2M); Use cases of M2M applications for eHealth	Under development	Technical Report	2009.7.9	
TR 102 857	Machine-to-Machine Communications (M2M); Use cases of M2M applications for Connected Consumer	Under development	Technical Report	2009.11.5	
TS 102 921	Machine-to-Machine communications (M2M); mla, dla and mld interfaces	Under development	Technical Specification	2012.3.2	
TR 102 966	Machine-to-Machine Communications (M2M); Interworking between the M2M Architecture and M2M Area Network technologies	Under development	Technical Report	2011.3.18	
TR 101 584	Machine-to-Machine communications (M2M) Study on Semantic support for M2M Data	Under development	Technical Report	2012.1.5	
TR 103 118	Machine-to-Machine communications (M2M); Smart Energy Infrastructures security; Review of existing security measures and convergence investigations	Under development	Technical Report	2012.7.19	

### Last updated

22 July, 2013



## GISFI

### Summary

Full name of (standards) body / group	<b>Global ICT Standardization Forum for India</b>
Membership	community of vendors, operators, manufacturers, service providers, academia
Website	<a href="http://www.gisfi.org/">http://www.gisfi.org/</a>

### Activities and documents

#### WG Green ICT

Full name of TC	
Full name of SC/WG	WG Green ICT
Chairman/Contact	Arvind Mathur
Website full description	<a href="http://www.gisfi.org/workinggroups.php?wg=GICT">http://www.gisfi.org/workinggroups.php?wg=GICT</a>
Summary of activities	The highest importance is introduction of ICT resources to the topic of climate change. This can be performed via monitoring climate change, via mitigation of local effects of climate change, via concerted action against global warming and via ICT standardization in the field of climate change.
Comments	

Name	Title	status	Type	Date	Hyperlink
GISFI_GICT_201302360	Metrics and Measurement Methods for Energy Efficiency: Classification of Telecom Equipments	Published	Technical Report	2013.2	<a href="http://www.gisfi.org/wg_documents/GISFI_GICT_201302360.zip">http://www.gisfi.org/wg_documents/GISFI_GICT_201302360.zip</a>
GISFI_GICT_201301357	Metrics and Measurement Methods for Energy Efficiency: General Requirements	Published	Technical Report	2013.6	<a href="http://www.gisfi.org/wg_documents/GISFI_GICT_201301357.zip">http://www.gisfi.org/wg_documents/GISFI_GICT_201301357.zip</a>
GISFI_GICT_201301389	Approach towards Implementation of Green Telecom in India	Published	Technical Report	2013.6	<a href="http://www.gisfi.org/wg_documents/GISFI_GICT_201301389.docx">http://www.gisfi.org/wg_documents/GISFI_GICT_201301389.docx</a>
GISFI_GICT_201212327	MoM Conference Call Green ICT 22 Nov. 2012	Published	Technical Report	2012.12	<a href="http://www.gisfi.org/wg_documents/GISFI_GICT_201212327.zip">http://www.gisfi.org/wg_documents/GISFI_GICT_201212327.zip</a>
GISFI_GICT_201212334	TR on Metrics and Measurement Methods for Energy Efficiency	Published	Technical Report	2012.12	<a href="http://www.gisfi.org/wg_documents/GISFI_GICT_201212334.doc">http://www.gisfi.org/wg_documents/GISFI_GICT_201212334.doc</a>
GISFI_GICT_201209293	GISFI#10 Green ICT Working Group: Activity Update and Agenda	Published	Technical Report	2012.9	<a href="http://www.gisfi.org/wg_documents/GISFI_GICT_201209293.zip">http://www.gisfi.org/wg_documents/GISFI_GICT_201209293.zip</a>
GISFI_GICT_201209295	Green Management	Published	Technical Report	2012.9	<a href="http://www.gisfi.org/wg_documents/GISFI_GICT_201209295.zip">http://www.gisfi.org/wg_documents/GISFI_GICT_201209295.zip</a>

#### Last updated

13 June, 2013

## IEC

## Summary

Full name of (standards) body / group	<b>International Electrotechnical Commission</b>
Membership	community of vendors, operators, manufacturers, service providers, academia
Website	<a href="http://www.iec.ch/index.htm">http://www.iec.ch/index.htm</a>

## Activities and documents

## SMB/SEG-1

Full name of TC	Standardization Management Board
Full name of SC/WG	System evaluation group (SEG-1) on smart cities
Chairman/Contact	Fumio Ueno
Website full description	<a href="http://www.iec.ch/dyn/www/?p=103:48:0:::FSP_ORG_ID,FSP_LANG_ID:3228,25#4">http://www.iec.ch/dyn/www/?p=103:48:0:::FSP_ORG_ID,FSP_LANG_ID:3228,25#4</a>
Summary of activities	<p>IEC SMB set up smart city system evaluation group in June 2013. As a first step SEG-1 formed 3 Task Groups with the aim of a) identifying state of the art and potential gaps to address the IEC standardization needs with respect to smart cities; b) filling any gaps by outlining a roadmap of smart cities standardization, architectures and prospective standardization projects including a reference architecture; and c) aligning terms and definitions in the electrotechnical field referring to smart cities. SEG-1 set up 8 working groups to research the market needs and relevance, business drivers that are relevant to the area being studied. The specific study areas from the working groups are:</p> <ul style="list-style-type: none"> <li>– WG1: City Service Continuity</li> <li>– WG2: Urban Planning and Simulation System</li> <li>– WG3: City Facilities Management</li> <li>– WG4: Use Case – Smart Homes</li> <li>– WG5: Use Case – Smart Education</li> <li>– WG6: Smart Cities Assessment</li> <li>– WG7: Standards development for Smart Cities – City of Johannesburg, South Africa</li> <li>– WG8: Mobility and Logistics in Cities</li> </ul> <p>For the purposes of harmonizing and advancing Smart City activities in the IEC, the SEG on Smart Cities recommends to transition into a full Systems Committee (SyC) on Smart Cities.</p>
Comments	

Name	Title	status	Type	Date	Hyperlink
SEG1/6A/DA	Revised Draft agenda for meeting 2 in Berlin	Published	information	2014-02-21	<a href="http://www.iec.ch/cgi-bin/restricted/getfile.pl/SEG1_6ea_DA.pdf?dir=SEG1&amp;format=pdf&amp;type= DA&amp;file=6ea.pdf">http://www.iec.ch/cgi-bin/restricted/getfile.pl/SEG1_6ea_DA.pdf?dir=SEG1&amp;format=pdf&amp;type= DA&amp;file=6ea.pdf</a>
SEG1/8/INF	Terms of Reference of SEG1 – Smart Cities	Published	information	2014-04-11	<a href="http://www.iec.ch/cgi-bin/restricted/getfile.pl/SEG1_8e_INF.pdf?dir=SEG1&amp;for">http://www.iec.ch/cgi-bin/restricted/getfile.pl/SEG1_8e_INF.pdf?dir=SEG1&amp;for</a>
SEG1/7/RM	Draft Report of the meeting held at DIN, Berlin, Germany, on 28th February 2014	Published	information	2014-04-11	<a href="http://www.iec.ch/cgi-bin/restricted/getfile.pl/SEG1_7e_RM.pdf?dir=SEG1&amp;format=pdf&amp;type= RM&amp;file=7e.pdf">http://www.iec.ch/cgi-bin/restricted/getfile.pl/SEG1_7e_RM.pdf?dir=SEG1&amp;format=pdf&amp;type= RM&amp;file=7e.pdf</a>
SEG1/9/INF	WG and TG meeting announcement: Hainan Island, China	Published	information	2014-04-25	<a href="http://www.iec.ch/cgi-bin/restricted/getfile.pl/SEG1_9e_INF.pdf?dir=SEG1&amp;format=pdf&amp;type= INF&amp;file=9e.pdf">http://www.iec.ch/cgi-bin/restricted/getfile.pl/SEG1_9e_INF.pdf?dir=SEG1&amp;format=pdf&amp;type= INF&amp;file=9e.pdf</a>
SEG1/10/INF	Draft- Table of contents of the final report to SMB from SEG1 Smart Cities, to be discussed at the WG meetings in Hainan	Published	information	2014-05-30	<a href="http://www.iec.ch/cgi-bin/restricted/getfile.pl/SEG1_10e_INF.pdf?dir=SEG1&amp;format=pdf&amp;type= INF&amp;file=10e.pdf">http://www.iec.ch/cgi-bin/restricted/getfile.pl/SEG1_10e_INF.pdf?dir=SEG1&amp;format=pdf&amp;type= INF&amp;file=10e.pdf</a>
SEG1/11/INF	Atlanta meeting announcement	Published	information	2014-06-20	<a href="http://www.iec.ch/cgi-bin/restricted/getfile.pl/SEG1_11e_INF.pdf?dir=SEG1&amp;format=pdf&amp;type= INF&amp;file=11e.pdf">http://www.iec.ch/cgi-bin/restricted/getfile.pl/SEG1_11e_INF.pdf?dir=SEG1&amp;format=pdf&amp;type= INF&amp;file=11e.pdf</a>
SEG1/12/Q	SEG 1 WGs and TGs Membership	Published	information	2014-06-27	<a href="http://www.iec.ch/cgi-bin/restricted/getfile.pl/SEG1_12e_Q.pdf?dir=SEG1&amp;format=pdf&amp;type= Q&amp;file=12e.pdf">http://www.iec.ch/cgi-bin/restricted/getfile.pl/SEG1_12e_Q.pdf?dir=SEG1&amp;format=pdf&amp;type= Q&amp;file=12e.pdf</a>
SEG1/13/DA	Draft agenda for the Atlanta meeting (3)	Published	information	2014-07-25	<a href="http://www.iec.ch/cgi-bin/restricted/getfile.pl/SEG1_13e_DA.pdf?dir=SEG1&amp;format=pdf&amp;type= DA&amp;file=13e.pdf">http://www.iec.ch/cgi-bin/restricted/getfile.pl/SEG1_13e_DA.pdf?dir=SEG1&amp;format=pdf&amp;type= DA&amp;file=13e.pdf</a>
SEG1/13A/DA	Revised Draft agenda for the Atlanta meeting (3)	Published	information	2014-08-01	<a href="http://www.iec.ch/cgi-bin/restricted/getfile.pl/SEG1_13ea_DA.pdf?dir=SEG1&amp;format=pdf&amp;type= DA&amp;file=13ea.pdf">http://www.iec.ch/cgi-bin/restricted/getfile.pl/SEG1_13ea_DA.pdf?dir=SEG1&amp;format=pdf&amp;type= DA&amp;file=13ea.pdf</a>
SEG1/14/INF	The German Standardization Roadmap Smart City	Published	information	2014-07-25	<a href="http://www.iec.ch/cgi-bin/restricted/getfile.pl/SEG1_14e_INF.pdf?dir=SEG1&amp;format=pdf&amp;type= INF&amp;file=14e.pdf">http://www.iec.ch/cgi-bin/restricted/getfile.pl/SEG1_14e_INF.pdf?dir=SEG1&amp;format=pdf&amp;type= INF&amp;file=14e.pdf</a>
SEG1/15/AC	WG 7: Standards Development for Smart Cities using the City of Johannesburg – Call for experts	Published	information	2014-10-10	<a href="http://www.iec.ch/cgi-bin/restricted/getfile.pl/SEG1_15e_AC.pdf?dir=SEG1&amp;format=pdf&amp;type= AC&amp;file=15e.pdf">http://www.iec.ch/cgi-bin/restricted/getfile.pl/SEG1_15e_AC.pdf?dir=SEG1&amp;format=pdf&amp;type= AC&amp;file=15e.pdf</a>

Name	Title	status	Type	Date	Hyperlink
SEG1/16/AC	WG 8: Mobility and Logistics – Call for Experts	Published	information	2014-10-10	<a href="http://www.iec.ch/cgi-bin/restricted/getfile.pl/SEG1_16e_AC.pdf?dir=SEG1&amp;format=pdf&amp;type=_AC&amp;file=16e.pdf">http://www.iec.ch/cgi-bin/restricted/getfile.pl/SEG1_16e_AC.pdf?dir=SEG1&amp;format=pdf&amp;type=_AC&amp;file=16e.pdf</a>
SEG1/17/RM	Draft minutes of the 3rd IEC SEG Smart Cities plenary meeting held in Atlanta, US on 23/24 September 2014	Published	information	2014-11-07	<a href="http://www.iec.ch/cgi-bin/restricted/getfile.pl/SEG1_17e_RM.pdf?dir=SEG1&amp;format=pdf&amp;type=_RM&amp;file=17e.pdf">http://www.iec.ch/cgi-bin/restricted/getfile.pl/SEG1_17e_RM.pdf?dir=SEG1&amp;format=pdf&amp;type=_RM&amp;file=17e.pdf</a>
SEG1/18B/AC	Next meeting of SEG1 – Smart Cities to be held in London, England 2015-03-09 to 2015-03-11	Published	information	2015-01-16	<a href="http://www.iec.ch/cgi-bin/restricted/getfile.pl/SEG1_18eb_AC.pdf?dir=SEG1&amp;format=pdf&amp;type=_AC&amp;file=18eb.pdf">http://www.iec.ch/cgi-bin/restricted/getfile.pl/SEG1_18eb_AC.pdf?dir=SEG1&amp;format=pdf&amp;type=_AC&amp;file=18eb.pdf</a>

### Last updated

22 April 2015

## IEEE

### Summary

Full name of (standards) body / group	<b>Institute of Electrical and Electronics Engineers</b>
Membership	community of scientists, engineers, manufacturers
Website	<a href="http://www.ieee.org/index.html">http://www.ieee.org/index.html</a>

### Activities and documents

#### 1. P1888 WG

Full name of TC	
Full name of SC/WG	Ubiquitous Green Community Control Network Protocol
Chairman/Contact	Liu Dong
Website full description	<a href="http://grouper.ieee.org/groups/1888/">http://grouper.ieee.org/groups/1888/</a>
Summary of activities	The standard describes a remote control architecture of digital community, intelligent building groups and digital metropolitan networks; specifies interactive data formats between devices and systems; and gives a standardized definition of equipment, service services, signals, and interactive messages in this digital community network
Comments	

## 2. P241 WG

Full name of TC	
Full name of SC/WG	Electrical Systems in Commercial Buildings
Chairman/Contact	R. G. Irvine
Website full description	<a href="http://grouper.ieee.org/groups/241/">http://grouper.ieee.org/groups/241/</a>
Summary of activities	Because of the increasing size and complexity of today's commercial buildings, there is a growing dependence on adequate and reliable electrical systems. The IEEE Gray Book provides extensive information on each of the various specialized subjects involved in planning the power system of a new or modernized commercial structure. The comprehensive source will alert the electrical engineer or designer to the many problems encountered in designing electrical systems for commercial buildings. Extensive information is presented on load requirements, power sources and distribution systems, supervisory, programmed, and security systems, and specialized occupancy buildings.
Comments	

## 3. P446 WG

Full name of TC	
Full name of SC/WG	Emergency and Standby Power
Chairman/Contact	James M. Daley
Website full description	<a href="http://grouper.ieee.org/groups/ias/446/index.html">http://grouper.ieee.org/groups/ias/446/index.html</a>
Summary of activities	This standard presents recommended engineering principles, practices, and guidelines for the selection, design, installation, application, operation, and maintenance of emergency and standby power systems. This information is primarily presented from a user's viewpoint; however, managing the effects of power system disturbances requires close cooperation between users, electric utilities, and equipment manufacturers.
Comments	

## 4. P739 WG

Full name of TC	
Full name of SC/WG	Energy Management in Commercial and Industrial Facilities
Chairman/Contact	James Angelo Ruggieri
Website full description	<a href="http://grouper.ieee.org/groups/739/index.htm">http://grouper.ieee.org/groups/739/index.htm</a>
Summary of activities	Home of the IEEE Bronze Book – IEEE STD 739. The IEEE Bronze Book is of great value to power-oriented engineers and designers associated with industrial and commercial facilities. The standard addresses energy conservation and cost-effective planning in the areas of engineering design, applications, utilization, and the operation and maintenance of electric power systems to provide for the optimal use of electrical energy.
Comments	

## 5. Flagship Initiative on Smart Cities

Full name of TC	Flagship Initiative on Smart Cities
Full name of SC/WG	
Chairman/Contact	Roberto Saracco
Website full description	<a href="http://ifa.itu.int/t/fg/ssc/docs/1305-Turin/in/fg-ssc-0024-telecom%20italia.zip">http://ifa.itu.int/t/fg/ssc/docs/1305-Turin/in/fg-ssc-0024-telecom%20italia.zip</a>
Summary of activities	<p>IEEE has launched a Flagship Initiative on SC.</p> <p>IEEE is open to a strong cooperation with other international bodies active on SC.</p> <p>IEEE wants to select at least 5 cities around the World to become their test and development areas.</p> <p>First has been Guadalajara <a href="http://portal.guadalajara.gob.mx/soy-ciudadano/noticias/selecciona-el-ieee-guadalajara-como-modelo-de-ciudad-inteligente">http://portal.guadalajara.gob.mx/soy-ciudadano/noticias/selecciona-el-ieee-guadalajara-como-modelo-de-ciudad-inteligente</a></p> <p>Then IEEE is looking for other cities in the various continents.</p>

### Last updated

22 July 2013

## ISO

### Summary

Full name of (standards) body/group	<b>International Organization for Standardization</b>
Membership	community of national standards bodies
Website	<a href="http://www.iso.org/iso/home.html">http://www.iso.org/iso/home.html</a>

### Activities and documents

#### 1. ISO/TC 268/SC 1

Full name of TC	Sustainable development in communities
Full name of SC/WG	Smart community infrastructures
Chairman/Contact	Yoshiaki Ichikawa
Website full description	<a href="http://www.iso.org/iso/home/store/catalogue_tc/catalogue_tc_browse.htm?commid=656967">http://www.iso.org/iso/home/store/catalogue_tc/catalogue_tc_browse.htm?commid=656967</a>



Summary of activities	<p>ISO/TC 268 will focus on the development of a management system standard, <b>ISO 37101</b> (Sustainable development and resilience of communities – Management systems – General principles and requirements), by building on <b>ISO 26000:2010</b> (Guidance on social responsibility). Another standard under development in the technical committee's work programme is <b>ISO 37120</b> (Sustainable development and resilience of communities – Global city indicators for city services and quality of life), which will help harmonize performance indicators in these fields. <b>ISO/TR 37150</b> will serve as a basis for the development of the future <b>ISO 37151</b> standard on harmonized metrics for benchmarking smartness of infrastructures.</p>
Comments	

Name	Title	status	Type	Date	Hyperlink
ISO 26000:2010	Guidance on social responsibility	Published	standard	2010.10.28	<a href="http://www.iso.org/iso/home/store/catalogue_tc/catalogue_detail.htm?csnumber=42546">http://www.iso.org/iso/home/store/catalogue_tc/catalogue_detail.htm?csnumber=42546</a>
ISO/AWI 37101	Sustainable development and resilience of communities – Management systems – General principles and requirements	Under development	standard	2012.8.22	<a href="http://www.iso.org/iso/home/store/catalogue_tc/catalogue_detail.htm?csnumber=61885">http://www.iso.org/iso/home/store/catalogue_tc/catalogue_detail.htm?csnumber=61885</a>
ISO/DIS 37120	Sustainable development and resilience of communities – Indicators for city services and quality of life	Under development	standard	2013.5.27	<a href="http://www.iso.org/iso/home/store/catalogue_tc/catalogue_detail.htm?csnumber=62436">http://www.iso.org/iso/home/store/catalogue_tc/catalogue_detail.htm?csnumber=62436</a>
ISO/AWI TR 37121	Inventory and review of existing indicators on sustainable development and resilience in cities	Under development	technical report	2013.6.27	<a href="http://www.iso.org/iso/home/store/catalogue_tc/catalogue_detail.htm?csnumber=63790">http://www.iso.org/iso/home/store/catalogue_tc/catalogue_detail.htm?csnumber=63790</a>
ISO/DTR 37150	Review of works relevant to smart community infrastructure metrics and future directions of standardization	Under development	technical report	2013.6.24	<a href="http://www.iso.org/iso/home/store/catalogue_tc/catalogue_detail.htm?csnumber=62564">http://www.iso.org/iso/home/store/catalogue_tc/catalogue_detail.htm?csnumber=62564</a>

## 2. ISO/TC 268/WG 1

Full name of TC	Sustainable development in communities
Full name of SC/WG	Management Systems Standards for sustainable development in communities
Chairman/Contact	Christian Bougeard
Website full description	
Summary of activities	ISO/TC 268/WG 1 is developing ISO 37101, which will then serve as a basis for the development of specific implementation standards tailored to communities.
Comments	

### 3. ISO/TC 268/WG 2

Full name of TC	Sustainable development in communities
Full name of SC/WG	Urban indicators
Chairman/Contact	Patricia McCarney
Website full description	
Summary of activities	ISO/TC 268/WG 2 aims for a harmonization of terminology, indicators and methods. Cities adopting this standard will then be better able to share their experience and knowledge. Besides, comparative analyses will help them assess their respective performance levels, which will encourage a healthy competitive spirit.
Comments	

### 4. ISO/TC 59/SC 17

Full name of TC	Buildings and civil engineering works
Full name of SC/WG	Sustainability in buildings and civil engineering works
Chairman/Contact	Jacques Lair
Website full description	<a href="http://www.iso.org/iso/home/store/catalogue_tc/catalogue_tc_browse.htm?commid=322621">http://www.iso.org/iso/home/store/catalogue_tc/catalogue_tc_browse.htm?commid=322621</a>
Summary of activities	ISO/TC 59/SC 17 focuses on environmental performance of buildings and researches on analysis of sustainability performance assessment methods used for civil engineering works.
Comments	

No.	Title	status	Type	Date	Hyperlink
ISO DTR 21932	Building construction – Sustainability in building construction – Terminology	Under development	technical report	2013.6.6	<a href="http://www.iso.org/iso/home/store/catalogue_tc/catalogue_detail.htm?csnumber=62888">http://www.iso.org/iso/home/store/catalogue_tc/catalogue_detail.htm?csnumber=62888</a>
ISO 21931-1:2010	Sustainability in building construction – Framework for methods of assessment of the environmental performance of construction works – Part 1: Buildings	Published	standard	2010.6.4	<a href="http://www.iso.org/iso/home/store/catalogue_tc/catalogue_detail.htm?csnumber=45559">http://www.iso.org/iso/home/store/catalogue_tc/catalogue_detail.htm?csnumber=45559</a>
ISO 21930:2007	Sustainability in building construction – Environmental declaration of building products	Published	standard	2012.3.2	<a href="http://www.iso.org/iso/home/store/catalogue_tc/catalogue_detail.htm?csnumber=40435">http://www.iso.org/iso/home/store/catalogue_tc/catalogue_detail.htm?csnumber=40435</a>

No.	Title	status	Type	Date	Hyperlink
ISO/NP 21930	Sustainability in buildings and civil engineering works – Environmental declaration of building products	Under development	standard	2012.6.18	<a href="http://www.iso.org/iso/home/store/catalogue_tc/catalogue_detail.htm?csnumber=61694">http://www.iso.org/iso/home/store/catalogue_tc/catalogue_detail.htm?csnumber=61694</a>
ISO/DIS 21929-2.2	Draft on sustainability in buildings and civil engineering works – Sustainability indicators – Part 2: Framework for the development of indicators for civil engineering works	Published	standard	2013.6.12	<a href="http://www.iso.org/iso/home/store/catalogue_tc/catalogue_detail.htm?csnumber=56066">http://www.iso.org/iso/home/store/catalogue_tc/catalogue_detail.htm?csnumber=56066</a>
ISO 21929-1 : 2011	Sustainability in building construction – Sustainability indicators – Part 1: Framework for the development of indicators and a core set of indicators for buildings	Published	standard	2011.11.8	<a href="http://www.iso.org/iso/home/store/catalogue_tc/catalogue_detail.htm?csnumber=46599">http://www.iso.org/iso/home/store/catalogue_tc/catalogue_detail.htm?csnumber=46599</a>
ISO/NP TR 18791	Analysis of sustainability performance assessment methods used for civil engineering works	Under development	technical report	2013.2.25	<a href="http://www.iso.org/iso/home/store/catalogue_tc/catalogue_detail.htm?csnumber=63388">http://www.iso.org/iso/home/store/catalogue_tc/catalogue_detail.htm?csnumber=63388</a>
ISO/DIS 16745	Environmental performance of buildings – Carbon Metric of a building – Use stage	Under development	standard	2013.6.12	<a href="http://www.iso.org/iso/home/store/catalogue_tc/catalogue_detail.htm?csnumber=57576">http://www.iso.org/iso/home/store/catalogue_tc/catalogue_detail.htm?csnumber=57576</a>
ISO 15392:2008	Sustainability in building construction – General principles	Published	standard	2011.9.17	<a href="http://www.iso.org/iso/home/store/catalogue_tc/catalogue_detail.htm?csnumber=40432">http://www.iso.org/iso/home/store/catalogue_tc/catalogue_detail.htm?csnumber=40432</a>
ISO/DTS 12720	Sustainability in buildings and civil engineering works – Guidelines for the application of the general principles on sustainability	Under development	standard	2013.6.30	<a href="http://www.iso.org/iso/home/store/catalogue_tc/catalogue_detail.htm?csnumber=51654">http://www.iso.org/iso/home/store/catalogue_tc/catalogue_detail.htm?csnumber=51654</a>

## 5. ISO/TC 163 & ISO/TC 205

Full name of TC	Thermal performance and energy use in the built environment
Full name of SC/WG	Test and measurement methods (SC1) Calculation methods (SC2) Thermal insulation products (SC3)
Chairman/ Contact	Egil Öfverholm
Website full description	<a href="http://www.iso.org/iso/home/store/catalogue_tc/catalogue_tc_browse.htm?commid=53476">http://www.iso.org/iso/home/store/catalogue_tc/catalogue_tc_browse.htm?commid=53476</a>
Summary of activities	Three ISO/TC 163 subcommittees (SCs) are responsible for the standards that define, calculate and test building elements, which are essential for ensuring the energy efficiency of buildings.
Comments	

Full name of TC	Building environment design
Full name of SC/WG	
Chairman/ Contact	Bill Swen
Website full description	<a href="http://www.iso.org/iso/home/store/catalogue_tc/catalogue_tc_browse.htm?commid=54740">http://www.iso.org/iso/home/store/catalogue_tc/catalogue_tc_browse.htm?commid=54740</a>
Summary of activities	ISO/TC 205 has published standards offering an integrated methodology for the design of high-performance indoor environments. These standards exist within the overarching framework of ISO 16813:2006, Building environment design – Indoor environment – General principles.  ISO 13153:2012 is intended to assist and support the developers of design guidelines, architects and other building-design professionals. The standard provides the framework to express such quantitative knowledge.
Comments	

Name	Title	status	Type	Date	Hyperlink
ISO/TR 16344:2012	Energy performance of buildings – Common terms, definitions and symbols for the overall energy performance rating and certification	Published	technical report	2012.10.12	<a href="http://www.iso.org/iso/home/store/catalogue_tc/catalogue_detail.htm?csnumber=56225">http://www.iso.org/iso/home/store/catalogue_tc/catalogue_detail.htm?csnumber=56225</a>
ISO 16346	Energy performance of buildings – Assessment of overall energy performance	Under development	standard	2013.4.11	<a href="http://www.iso.org/iso/home/store/catalogue_tc/catalogue_detail.htm?csnumber=56226">http://www.iso.org/iso/home/store/catalogue_tc/catalogue_detail.htm?csnumber=56226</a>
ISO 16343	Energy performance of buildings – Methods for expressing energy performance and for energy certification of buildings	Under development	standard	2013.4.11	<a href="http://www.iso.org/iso/home/store/catalogue_tc/catalogue_detail.htm?csnumber=56224">http://www.iso.org/iso/home/store/catalogue_tc/catalogue_detail.htm?csnumber=56224</a>

ISO 12655:2013	Energy performance of buildings – Presentation of measured energy use of buildings	Published	standard	2013.3.6	<a href="http://www.iso.org/iso/home/store/catalogue_tc/catalogue_detail.htm?csnumber=51634">http://www.iso.org/iso/home/store/catalogue_tc/catalogue_detail.htm?csnumber=51634</a>
ISO 13153:2012	Framework of the design process for energy-saving single-family residential and small commercial buildings	Published	standard	2012.8.22	<a href="http://www.iso.org/iso/home/store/catalogue_tc/catalogue_detail.htm?csnumber=53401">http://www.iso.org/iso/home/store/catalogue_tc/catalogue_detail.htm?csnumber=53401</a>

## 6. ISO/TC 257

Full name of TC	Evaluation of energy savings
Full name of SC/WG	
Chairman/Contact	Li Tienan
Website full description	<a href="http://www.iso.org/iso/home/store/catalogue_tc/catalogue_tc_browse.htm?commid=622828">http://www.iso.org/iso/home/store/catalogue_tc/catalogue_tc_browse.htm?commid=622828</a>
Summary of activities	Prior working items include general technical rules and some fundamental methodologies. These subjects will build the framework of principles and essential guidelines for developing special methodologies in different levels of items.
Comments	

Name	Title	status	Type	Date	Hyperlink
ISO 17741	General technical rules for measurement, calculation and verification of energy savings of projects	Under development	standard	2012.4.5	<a href="http://www.iso.org/iso/home/store/catalogue_tc/catalogue_detail.htm?csnumber=60373">http://www.iso.org/iso/home/store/catalogue_tc/catalogue_detail.htm?csnumber=60373</a>
ISO 17742	General calculation methods on energy efficiency and savings for countries, regions or cities	Under development	standard	2013.6.29	<a href="http://www.iso.org/iso/home/store/catalogue_tc/catalogue_detail.htm?csnumber=60374">http://www.iso.org/iso/home/store/catalogue_tc/catalogue_detail.htm?csnumber=60374</a>
ISO 17743	Definition of a methodological framework applicable to calculation and reporting on energy savings	Under development	standard	2013.6.29	<a href="http://www.iso.org/iso/home/store/catalogue_tc/catalogue_detail.htm?csnumber=60376">http://www.iso.org/iso/home/store/catalogue_tc/catalogue_detail.htm?csnumber=60376</a>
ISO 17747	General calculation methods on energy efficiency and savings for organizations and other enterprises	Under development	standard	2012.9.20	<a href="http://www.iso.org/iso/home/store/catalogue_tc/catalogue_detail.htm?csnumber=62224">http://www.iso.org/iso/home/store/catalogue_tc/catalogue_detail.htm?csnumber=62224</a>

## 7. ISO/TC 223

Full name of TC	Societal security
Full name of SC/WG	
Chairman/Contact	Åsa Kyrk Gere
Website full description	<a href="http://www.iso.org/iso/home/store/catalogue_tc/catalogue_tc_browse.htm?commid=295786">http://www.iso.org/iso/home/store/catalogue_tc/catalogue_tc_browse.htm?commid=295786</a>
Summary of activities	ISO/TC 223 is developing International Standards to boost urban resilience.
Comments	

Name	Title	status	Type	Date	Hyperlink
ISO 22316	Societal security – Organizational resilience – Principles and guidelines	Under development	standard	2013.4.11	<a href="http://www.iso.org/iso/home/store/catalogue_tc/catalogue_detail.htm?csnumber=50053">http://www.iso.org/iso/home/store/catalogue_tc/catalogue_detail.htm?csnumber=50053</a>
ISO 22301:2012	Societal security – Business continuity management systems – Requirements	Published	standard	2012.5.15	<a href="http://www.iso.org/iso/home/store/catalogue_tc/catalogue_detail.htm?csnumber=50038">http://www.iso.org/iso/home/store/catalogue_tc/catalogue_detail.htm?csnumber=50038</a>
ISO 22313:2012	Societal security – Business continuity management systems – Guidance	Published	standard	2012.12.12	<a href="http://www.iso.org/iso/home/store/catalogue_tc/catalogue_detail.htm?csnumber=50050">http://www.iso.org/iso/home/store/catalogue_tc/catalogue_detail.htm?csnumber=50050</a>
ISO 22398	Societal security – Guidelines for exercises	Under development	standard	2013.5.22	<a href="http://www.iso.org/iso/home/store/catalogue_tc/catalogue_detail.htm?csnumber=50294">http://www.iso.org/iso/home/store/catalogue_tc/catalogue_detail.htm?csnumber=50294</a>
ISO 22320:2011	Societal security – Emergency management – Requirements for incident response	Published	standard	2011.11.2	<a href="http://www.iso.org/iso/home/store/catalogue_tc/catalogue_detail.htm?csnumber=53347">http://www.iso.org/iso/home/store/catalogue_tc/catalogue_detail.htm?csnumber=53347</a>
ISO 22322	Societal security – Emergency management – Public warning	Published	standard	2013.4.11	<a href="http://www.iso.org/iso/home/store/catalogue_tc/catalogue_detail.htm?csnumber=53335">http://www.iso.org/iso/home/store/catalogue_tc/catalogue_detail.htm?csnumber=53335</a>
ISO 22324	Societal security – Emergency management – Colour-coded alert	Published	standard	2013.6.28	<a href="http://www.iso.org/iso/home/store/catalogue_tc/catalogue_detail.htm?csnumber=50061">http://www.iso.org/iso/home/store/catalogue_tc/catalogue_detail.htm?csnumber=50061</a>



## 8. ISO/TC 241

Full name of TC	Road traffic safety management systems
Full name of SC/WG	
Chairman/Contact	Claes Tingvall
Website full description	<a href="http://www.iso.org/iso/home/store/catalogue_tc/catalogue_tc_browse.htm?commid=558313">http://www.iso.org/iso/home/store/catalogue_tc/catalogue_tc_browse.htm?commid=558313</a>
Summary of activities	ISO 39001 outlines a management system to enable these organizations to integrate safety into their use of roads. The standard will help them improve safety in a structured and simple way.
Comments	Only Chinese description provided

Name	Title	status	Type	Date	Hyperlink
ISO 39001	Road traffic safety (RTS) management systems – Requirements with guidance for use	Published	standard	2012.10.1	<a href="http://www.iso.org/iso/home/store/catalogue_tc/catalogue_detail.htm?csnumber=44958">http://www.iso.org/iso/home/store/catalogue_tc/catalogue_detail.htm?csnumber=44958</a>

## 9. ISO/TC 204

Full name of TC	Intelligent transport systems
Full name of SC/WG	
Chairman/Contact	Belinda Collins
Website full description	<a href="http://www.iso.org/iso/home/store/catalogue_tc/catalogue_tc_browse.htm?commid=54706">http://www.iso.org/iso/home/store/catalogue_tc/catalogue_tc_browse.htm?commid=54706</a>
Summary of activities	TC204 is being working around the standardization of urban and rural land transport in information systems, communication systems and control systems, including multimodal traveler information, traffic management, public transport, commercial transport, emergency services, business services. It is often referred to as "intelligent transportation system."
Comments	

No.	Title	status	Type	Date	Hyperlink
ISO 10711:2012	Intelligent Transport Systems – Interface Protocol and Message Set Definition between Traffic Signal Controllers and Detectors	published	standard	2012.1.12	<a href="http://www.iso.org/iso/home/store/catalogue_tc/catalogue_detail.htm?csnumber=46069">http://www.iso.org/iso/home/store/catalogue_tc/catalogue_detail.htm?csnumber=46069</a>
ISO/TR 10992:2011	Intelligent transport systems – Use of nomadic and portable devices to support ITS service and multimedia provision in vehicles	published	Technical report	2011.12.16	<a href="http://www.iso.org/iso/home/store/catalogue_tc/catalogue_detail.htm?csnumber=46550">http://www.iso.org/iso/home/store/catalogue_tc/catalogue_detail.htm?csnumber=46550</a>

No.	Title	status	Type	Date	Hyperlink
ISO/CD 11067	Intelligent transport systems – Curve speed warning systems (CSWS) – Performance requirements and test procedures	Under development	Committee Draft	2013.4.4	<a href="http://www.iso.org/iso/home/store/catalogue_tc/catalogue_detail.htm?csnumber=50091">http://www.iso.org/iso/home/store/catalogue_tc/catalogue_detail.htm?csnumber=50091</a>
ISO/DIS 11270	Intelligent transport systems – Lane keeping assistance systems (LKAS) – Performance requirements and test procedures	Under development	Draft International Standard	2013.5.13	<a href="http://www.iso.org/iso/home/store/catalogue_tc/catalogue_detail.htm?csnumber=50347">http://www.iso.org/iso/home/store/catalogue_tc/catalogue_detail.htm?csnumber=50347</a>

## 10. ISO/TC 215

Full name of TC	Health informatics
Full name of SC/WG	
Chairman/Contact	Yun Sik Kwak
Website full description	<a href="http://www.iso.org/iso/home/store/catalogue_tc/catalogue_tc_browse.htm?commid=54960">http://www.iso.org/iso/home/store/catalogue_tc/catalogue_tc_browse.htm?commid=54960</a>
Summary of activities	Standardization in the field of information for health, and Health Information and Communications Technology (ICT) to promote interoperability between independent systems, to enable compatibility and consistency for health information and data, as well as to reduce duplication of effort and redundancies.
Comments	

Name	Title	status	Type	Date	Hyperlink
ISO/HL7 DIS 10781	Electronic Health Record-System Functional Model, Release 2.0 (EHR FM)	Under development	Draft International Standard	2012.11.21	<a href="http://www.iso.org/iso/home/store/catalogue_tc/catalogue_detail.htm?csnumber=57757">http://www.iso.org/iso/home/store/catalogue_tc/catalogue_detail.htm?csnumber=57757</a>
ISO/IEEE 11073-30400:2012	Health informatics – Point-of-care medical device communication – Part 30400: Interface profile – Cabled Ethernet	Published	standard	2012.10.26	<a href="http://www.iso.org/iso/home/store/catalogue_tc/catalogue_detail.htm?csnumber=61068">http://www.iso.org/iso/home/store/catalogue_tc/catalogue_detail.htm?csnumber=61068</a>
ISO 11615:2012	Health informatics – Identification of medicinal products – Data elements and structures for the unique identification and exchange of regulated medicinal product information	Published	standard	2012.10.26	<a href="http://www.iso.org/iso/home/store/catalogue_tc/catalogue_detail.htm?csnumber=55034">http://www.iso.org/iso/home/store/catalogue_tc/catalogue_detail.htm?csnumber=55034</a>
ISO 11616:2012	Health informatics – Identification of medicinal products – Data elements and structures for the unique identification and exchange of regulated pharmaceutical product information	Published	standard	2012.10.26	<a href="http://www.iso.org/iso/home/store/catalogue_tc/catalogue_detail.htm?csnumber=55035">http://www.iso.org/iso/home/store/catalogue_tc/catalogue_detail.htm?csnumber=55035</a>

Name	Title	status	Type	Date	Hyperlink
ISO 13119:2012	Health informatics – Clinical knowledge resources – Metadata	Published	standard	2012.10.26	<a href="http://www.iso.org/iso/home/store/catalogue_tc/catalogue_detail.htm?csnumber=52951">http://www.iso.org/iso/home/store/catalogue_tc/catalogue_detail.htm?csnumber=52951</a>
ISO/TR 13054:2012	Knowledge management of health information standards	Published	Technical report	2012.7.31	<a href="http://www.iso.org/iso/home/store/catalogue_tc/catalogue_detail.htm?csnumber=52465">http://www.iso.org/iso/home/store/catalogue_tc/catalogue_detail.htm?csnumber=52465</a>
ISO/TS 13582:2013	Health informatics – Sharing of OID registry information	Published	Technical specification	2013.3.14	<a href="http://www.iso.org/iso/home/store/catalogue_tc/catalogue_detail.htm?csnumber=54037">http://www.iso.org/iso/home/store/catalogue_tc/catalogue_detail.htm?csnumber=54037</a>
ISO 1828:2012	Health informatics – Categorical structure for terminological systems of surgical procedures	Published	standard	2012.9.12	<a href="http://www.iso.org/iso/home/store/catalogue_tc/catalogue_detail.htm?csnumber=52388">http://www.iso.org/iso/home/store/catalogue_tc/catalogue_detail.htm?csnumber=52388</a>

## 11. ISO/TMB SAG on smart cities

Full name of TMBG	Strategic Advisory Group (SAG) on smart cities
Full name of SC/WG	
Chairman/Contact	Chairman: Graham Colclough / Secretary: Francesco Dadaglio
Website full description	<a href="http://www.iso.org/iso/standards_development/technical_committees/other_bodies/iso_technical_committee.htm?commid=54996">http://www.iso.org/iso/standards_development/technical_committees/other_bodies/iso_technical_committee.htm?commid=54996</a> ISO/TMB SAG on Smart City
Summary of activities	The Smart Cities SAG are working on: 1) delivering an action plan to the TMB with the topics agreed; 2) producing a mapping of the work going on in SDOs on the smart cities topic by assigning the work to individual "leaders".
Comments	

### Last updated

10 February, 2015

## ISO/IEC JTC1

### Summary

Full name of (standards) body/group	<b>International Organization for Standardization / International Electrotechnical Commission</b>
Membership	
Website	

### Activities and documents

#### JTC1 / SG1 Smart Cities

Full name of TC	Joint Technical Committee – Information technology
Full name of SC/WG	SG1 Smart Cities
Chairman/Contact	Yuan Yuan / Tangli Liu
Website full description	<a href="http://www.iso.org/iso/home/store/catalogue_tc/catalogue_tc_browse.htm?commid=45020">http://www.iso.org/iso/home/store/catalogue_tc/catalogue_tc_browse.htm?commid=45020</a>
Summary of activities	<p>In June 2013, JTC1 Special Working Group planning meeting in Paris approved the proposal that China initiate establishment of Smart City Study Group. JTC1 plans to cooperate with ISO and IEC.</p> <p>Its terms of reference include:</p> <ol style="list-style-type: none"> <li>1. Provide a description of key concepts related to Smart Cities and describe relevant terminology.</li> <li>2. Study and document the technological, market and societal requirements for the ICT standardization aspects of Smart Cities.</li> <li>3. Study and document current technologies that are being deployed to enable Smart Cities.</li> <li>4. Assess the current state of standardization activities relevant to Smart Cities within JTC 1, in other relevant ISO and IEC TCs, in other SDOs and in consortia.</li> <li>5. Identify and propose how JTC 1 should address the ICT standardization needs of Smart Cities.</li> <li>6. Provide a report with recommendations, and potentially other deliverables, to the 2014 JTC 1 Plenary.</li> </ol> <p>SG1 Smart Cities is working on a report “Report on standardization needs for Smart Cities”.</p>
Comments	

#### Last updated

24 April 2015

## TIA

### Summary

Full name of (standards) body/group	<b>Telecommunications Industry Association</b>
Membership	community of vendors, operators, manufacturers, service providers, academia
Website	<a href="http://www.tiaonline.org/">http://www.tiaonline.org/</a>

### Activities and documents

#### TIA/CCSC

Full name of TC	
Full name of SC/WG	Cloud Computing Subcommittee
Chairman/Contact	Betsy Covell
Website full description	<a href="http://www.tiaonline.org/all-standards/cloud-computing-subcommittee">http://www.tiaonline.org/all-standards/cloud-computing-subcommittee</a>
Summary of activities	Acting as a liaison between TIA's twelve engineering committees, the CCSC hosts monthly calls open to TIA member companies and engineering committee participants. The focus of these calls is to address ways TIA engineering committees may develop or amend TIA standards pertaining to cloud services. The CCSC also maintains liaison relationships with national and international standards development organizations (SDOs) to determine how existing TIA standards may be adopted to avoid duplication of efforts.
Comments	

Name	Title	status	Type	Date	Hyperlink
	White Paper on Cloud Computing	Published	White Paper	2011.8.18	<a href="http://www.tiaonline.org/standards/TIA_Cloud_Computing_White_Paper.pdf">http://www.tiaonline.org/standards/TIA_Cloud_Computing_White_Paper.pdf</a>
ANSI/TIA-942-A	Telecommunications Infrastructure Standards for Data Centers	Published	Technical Standard	2013.3.26	<a href="http://global.ihs.com/search_res.cfm?RID=TIA&amp;INPUT_DOC_NUMBER=ANSI/TIA-942">http://global.ihs.com/search_res.cfm?RID=TIA&amp;INPUT_DOC_NUMBER=ANSI/TIA-942</a>
ANSI/TIA-568-C Series	Commercial Building Telecommunications Cabling Standards	Published	Technical Standard	2012.8	<a href="http://global.ihs.com/search_res.cfm?RID=TIA&amp;INPUT_DOC_NUMBER=ANSI/TIA-568">http://global.ihs.com/search_res.cfm?RID=TIA&amp;INPUT_DOC_NUMBER=ANSI/TIA-568</a>

#### Last updated

26 March 2013

## 5 Other organizations and their work on SSC

### RECI – Spanish Networks of Smart Cities (Red Española de Ciudades Inteligentes)

#### Summary

Full name of (city programs) body / group	<b>Spanish Networks of Smart Cities (Red Española de Ciudades Inteligentes)</b>
Membership	RECI currently consists of 41 municipalities.
Website	<a href="http://www.redciudadesinteligentes.es/">http://www.redciudadesinteligentes.es/</a>

#### Activities and output documents

Full name of TC	[full name]
Full name of SC/WG	[full name]
Chairman/Contact	Presidencia: Iñigo de la Serna Hernáiz, representante del Ayuntamiento de Santander.
Website full description	<a href="http://www.redciudadesinteligentes.es/sobre-la-red/quienes-somos/ampliar.php/Id_contenido/301/v/0/">http://www.redciudadesinteligentes.es/sobre-la-red/quienes-somos/ampliar.php/Id_contenido/301/v/0/</a>
Summary of activities	<p>RECI positions itself as an association of local territories whose entities, which are part of the network, are representative of the area and lead innovation systems in their own sphere by promoting their own local network of agents related to research and innovation. Its aim is to share experiences and work together to develop a sustainable management model and improve the quality of life of citizens, focusing on aspects such as energy saving, sustainable mobility, eGovernment, people care or safety.</p> <p>RECI is configured as a national association, open to the incorporation of other municipalities. The Association aims at the generation of a dynamic between cities in order to have a "Spanish network of smart cities" which should promote automatic and efficient management of infrastructure and urban services, and the reduction of public expenditure and improving the quality of services, thereby achieving attract economic activity and generating progress.</p> <p>They have 5 working groups: #1 Social innovation; #2 Energy; #3 Environment, Infrastructure and Habitability; #4 Urban mobility and #5 Government, Economics and Business</p>
Comments	[e.g., structure of group, working parties, etc.]

Name	Title	status	Type	Date	Hyperlink
Green Cities y Sostenibilidad 2013	Green Cities and Sustainability	Upcoming	Meeting	2-3 Oct 2013	<a href="http://www.redciudadesinteligentes.es/agenda/ampliar.php/Id_contenido/1056/v/0/">http://www.redciudadesinteligentes.es/agenda/ampliar.php/Id_contenido/1056/v/0/</a>



## CDP. CARBON DISCLOSURE PROJECT

### Summary

Full name of (city programs) body / group	<b>Carbon Disclosure Project</b>
Membership	<p><b>Investors</b></p> <p>CDP investor initiatives backed in 2013 by more than 722 institutional investors representing an excess of US\$87 trillion in assets</p> <p><b>Companies</b></p> <p>Thousands of companies around the world from medium sized enterprises to large publicly quoted corporations</p> <p><b>Cities</b></p> <p>CDP's cities program provides a voluntary climate change reporting platform for city governments. The program is open to any city government, regardless of size or geographic location.</p> <p><b>Government and Policy Makers</b></p> <p>CDP has received funding from various governments around the world, including the governments of Australia, Canada, France, Germany, Singapore, Spain, Sweden, Denmark, UK and USA. CDP has various statements of support from the Ministers of the Governments of Australia, Canada, Denmark, EU, France, Ireland, Japan, Korea, Netherlands, South Africa, Spain, Sweden and Switzerland. CDP is also supported by various Mayors around the world, including Mayor of Toronto, Mayor of New York City; and Mayor of London.</p>
Website	<a href="http://www.cdproject.net/">http://www.cdproject.net/</a>

### Activities and output documents

Full name of TC	[full name]
Full name of SC/WG	Climate Disclosure Standards Board (CDSB) CDP Cities Program
Chairman/Contact	Executive Chairman. Paul Dickinson Paul Simpson, Chief Executive Officer Conor Riffle, Head of CDP's cities program
Website full description	<p>Cities</p> <p><a href="https://www.cdproject.net/en-US/Programmes/Pages/CDP-Cities.aspx">https://www.cdproject.net/en-US/Programmes/Pages/CDP-Cities.aspx</a></p> <p><a href="https://www.cdproject.net/en-US/Results/Pages/cities-Reports.aspx">https://www.cdproject.net/en-US/Results/Pages/cities-Reports.aspx</a></p> <p>Climate Change</p> <p><a href="https://www.cdproject.net/en-US/Results/Pages/All-Investor-Reports.aspx">https://www.cdproject.net/en-US/Results/Pages/All-Investor-Reports.aspx</a></p>

Summary of activities	<p>CDP works to transform the way the world does business to prevent dangerous climate change and protect our natural resources.</p> <p>CDP collects climate change data from organizations in some 60 countries world-wide.</p> <p>CDP uses the power of measurement and information disclosure to improve the management of environmental risk. By leveraging market forces including shareholders, customers and governments, CDP has incentivized thousands of companies and cities across the world's largest economies to measure and disclose their environmental information. CDP puts this information at the heart of business, investment and policy decision making.</p> <p>CDP holds the largest collection globally of self reported climate change, water and forest-risk data. Through their global system companies, investors and cities are better able to mitigate risk, capitalize on opportunities and make investment decisions that drive action towards a more sustainable world.</p> <p>CDP's cities program provides a voluntary climate change reporting platform for city governments, with benefits related to yield results, personalized feedback, learning opportunity and visibility. CDP's cities program is the largest global reporting platform for cities. Participating in the program is a great way to network with other cities and share best practices.</p>
Comments	[e.g., structure of group, working parties, etc.]

Name	Title	status	Type	Date	Hyperlink
Wealthier, Healthier Cities	Cities 2013 Global Report: Wealthier, healthier cities	Published	Report	2013	<a href="https://www.cdproject.net/CDPResults/CDP-Cities-2013-Global-Report.pdf">https://www.cdproject.net/CDPResults/CDP-Cities-2013-Global-Report.pdf</a>
CDP Cities 2013	Cities 2013 Summary Report.	Published	Report	2013	<a href="https://www.cdproject.net/CDPResults/CDP-Cities-2013-usage-summary.pdf">https://www.cdproject.net/CDPResults/CDP-Cities-2013-usage-summary.pdf</a>

## AHCIET

### Summary

Full name of (city programs) body / group	Asociación Iberoamericana de Centros de Investigación y Empresas de Telecomunicaciones, – AHCIET
Membership	Composed of over 50 telecommunication operators in Latin America, which include public, private, multinational and local diversity provides a significant representation of the entire industry.
Website	<a href="http://www.ahciet.net">http://www.ahciet.net</a>

## Activities and output documents

Full name of TC	[full name]
Full name of SC/WG	[full name]
Chairman/Contact	[name of chairman or coordinator, if applicable]
Website full description	[detailed source for summary]
Summary of activities	<p>AHCIET is a private, nonprofit, founded in 1982. Its mission is to contribute decisively to the development of telecommunications in Latin America through public-private dialogue, promoting the common interests of the industry and the exchange of knowledge and best practices between companies, thus, advance the development of connectivity and digital telecommunications.</p> <p>The strategic objectives of the Association, are based on promoting the sustainable development of industry in this line, evaluates and defines critical issues affecting the sector development in the region, makes them monitor the risks and opportunities in the sector established in each country. It also builds consensus positions on critical issues and disseminates industry prospects.</p> <p>AHCIET actively participates in industry events and national and regional debates, to promote and defend the common interests of the industry and its partners. Has 14 years in charge of the organization and development of Latin American Meeting on Digital Cities.</p>
Comments	[e.g., structure of group, working parties, etc.]

Name	Title	status	Type	Date	Hyperlink
Latin American Meeting on Digital Cities.	XIV Latin American Meeting on Digital Cities [XIV Encuentro Iberoamericano de Ciudades Digitales]	Under development	Workshop	25-26 September	<a href="http://www.ciudadesdigitales2013.com/">http://www.ciudadesdigitales2013.com/</a>
Premios AHCIET	Ninth Convocation of Latin American Digital Cities Award. [IX Convocatoria del Premio Iberoamericano de Ciudades Digitales.]	Past	Challenge	April 2013	<a href="http://ciudades.yage.ec/wp-content/uploads/2013/05/BASES-CONVOCATORIA-DEL-PREMIO.pdf">http://ciudades.yage.ec/wp-content/uploads/2013/05/BASES-CONVOCATORIA-DEL-PREMIO.pdf</a>

### Last updated

9 September 2013

## C40 Cities Climate Leadership Group

### Summary

Full name of (city programs) body / group	C40 Cities Climate Leadership Group
Membership	C40 is a network of the world's megacities taking action to addressing climate change and reduce greenhouse gas emissions. <b>Partners and Funders:</b> <a href="http://www.c40cities.org/partnerships">http://www.c40cities.org/partnerships</a>
Website	<a href="http://www.c40cities.org/home">http://www.c40cities.org/home</a>

### Activities and output documents

Full name of TC	[full name]
Full name of SC/WG	[full name]
Chairman/Contact	The current chair of C40 is New York City Mayor Michael R. Bloomberg who leads the C40 together with the steering committee and executive leadership team.
Website full description	<a href="http://www.c40cities.org/about">http://www.c40cities.org/about</a>
Summary of activities	<p>C40 offers cities an effective forum where they can collaborate, share knowledge and drive meaningful, measurable and sustainable action on climate change. With a unique set of assets, the C40 works with participating cities to address climate risks and impacts locally and globally.</p> <p>C40 is committed to implementing meaningful and sustainable climate-related actions locally that will help address climate change globally. Their global field staff works with city governments, supported by technical experts across a range of program areas. Together they facilitate active exchange and collaboration across cities. C40 works to empower cities to connect with each other and share technical expertise on best practices.</p> <p>The C40 Cities Climate Leadership Group (C40) is a network of large and engaged cities from around the world.</p>
Comments	[e.g., structure of group, working parties, etc.]

Name	Title	status	Type	Date	Hyperlink
C40 Mayors Summit	Fifth biennial C40 Mayors Summit	Under development	Workshop	4-6 02 2014	<a href="http://www.c40cities.org/c40events/johannesburg-to-host-2014-mayors-summit">http://www.c40cities.org/c40events/johannesburg-to-host-2014-mayors-summit</a>
C40 & Siemens City Climate Leadership Awards	C40 & Siemens City Climate Leadership Awards	Past	Challenge	4-6 02 2014	<a href="http://www.c40cities.org/c40events/johannesburg-to-host-2014-mayors-summit">http://www.c40cities.org/c40events/johannesburg-to-host-2014-mayors-summit</a>
Wealthier, Healthier Cities	Cities 2013 Global Report: Wealthier, healthier cities	Published	Report	2013	<a href="https://www.cdproject.net/CDPResults/CDP-Cities-2013-Global-Report.pdf">https://www.cdproject.net/CDPResults/CDP-Cities-2013-Global-Report.pdf</a>

## ICLEI. Local Governments for Sustainability

### Summary

Full name of (city programs) body / group	ICLEI. Local Governments for Sustainability
Membership	<p>ICLEI is a powerful movement of 12 mega-cities, 100 super-cities &amp; urban regions, 450 large cities, 450 small &amp; medium-sized cities &amp; towns in 85 countries dedicated to sustainable development.</p> <p>ICLEI encompasses a number of networks: a network of local governments that facilitates city-to-city cooperation; thematic networks that bring together cities leading the way on key sustainability issues like water quality and quantity, renewable energy, and urban disaster risk reduction; and a network of individuals, the leaders of their respective institutions.</p> <p>All about members: <a href="http://www.iclei.org/our-members/iclei-members.html">http://www.iclei.org/our-members/iclei-members.html</a></p>
Website	<a href="http://www.iclei.org/">http://www.iclei.org/</a>

### Activities and output documents

Full name of TC	[full name]
Full name of SC/WG	[full name]
Chairman/ Contact	The current President of ICLEI Global Executive Committee is David Coleman
Website full description	<a href="http://www.iclei.org/iclei-global/who-is-iclei.html">http://www.iclei.org/iclei-global/who-is-iclei.html</a>
Summary of activities	<p>ICLEI is the world's leading association of cities and local governments dedicated to sustainable development. ICLEI supports cities and local governments in working towards sustainability, whether they are pursuing the ambitious goal to become an eco-city/green city or focusing on specific goals.</p> <p>ICLEI promotes local action for global sustainability and supports cities to become sustainable, resilient, resource-efficient, bio diverse, low-carbon; to build a smart infrastructure; and to develop an inclusive, green urban economy with the ultimate aim to achieve healthy and happy communities.</p> <p>ICLEI's mission is to build and serve a worldwide movement of local governments to achieve tangible improvements in global sustainability with specific focus on environmental conditions through cumulative local actions.</p>
Comments	ICLEI events bring local government representatives together with experts, business and industry leaders, academics, national and international governmental representatives and civil society, to exchange face-to-face on solutions to the wide spectrum of challenges facing cities.

Name	Title	status	Type	Date	Hyperlink
Thriving Neighbourhoods 2013 Conference	Thriving Neighbourhoods 2013 Conference	Upcoming	Conference	28-30 Oct 2013	<a href="http://www.iclei.org/details/article/thriving-neighbourhoods-2013-conference.html">http://www.iclei.org/details/article/thriving-neighbourhoods-2013-conference.html</a>
EcoMobility World Festival 2013	EcoMobility World Festival 2013	Current	Festival	1-10 September	<a href="http://www.iclei.org/details/article/ecomobility-world-festival-2013.html">http://www.iclei.org/details/article/ecomobility-world-festival-2013.html</a>
ICLEI World Congress	ICLEI World Congress	Upcoming	Congress	2015	<a href="http://www.iclei.org/our-activities/events/iclei-world-congress.html">http://www.iclei.org/our-activities/events/iclei-world-congress.html</a>
The Economy of Green Cities	The Economy of Green Cities: A world Compendium on the Green Urban Economy	Published	Book	2013	<a href="http://www.iclei.org/our-activities/events/iclei-world-congress.html">http://www.iclei.org/our-activities/events/iclei-world-congress.html</a>
Various	Programs and Initiatives	Upcoming	Programs		<a href="http://www.iclei.org/our-activities/programs-initiatives.html">http://www.iclei.org/our-activities/programs-initiatives.html</a>
Various	Services and Networks	Permanent	Tools, Services and Networks		<a href="http://www.iclei.org/our-activities/our-agendas/sustainable-city.html">http://www.iclei.org/our-activities/our-agendas/sustainable-city.html</a>
Various	Research and Consulting activities	Permanent	Services		<a href="http://www.iclei.org/our-activities/research-consulting.html">http://www.iclei.org/our-activities/research-consulting.html</a>

### Last updated

9 September 2013

## The City Protocol Society

### Summary

Full name of (city programs) body / group	The City Protocol Society
Membership	<p>The City Protocol Society is a global non-profit community of cities, corporations, academic and nonprofit organizations taking collaborative action to help cities face their challenges together and enable the development of more sustainable, efficient and innovative solutions for city initiatives.</p> <p>To accomplish their work, they support an open community of experts, the <b>City Protocol Task Force</b>, who collaborate together in the research and development, necessary to offer curated guidance and collaborative action so that cities do not have to navigate their transformation journeys alone.</p> <p>They invite city-focused institutions and individual experts to join them as institutional members and participants to collaborate closely with impactful leading global city initiatives.</p> <p>All about members: <a href="http://cityprotocol.org/members.html">http://cityprotocol.org/members.html</a></p>
Website	<a href="http://www.cityprotocol.org">http://www.cityprotocol.org</a>



### Activities and output documents

Full name of TC	[full name]
Full name of SC/WG	[full name]
Chairman/Contact	The current chair of The City Protocol Society is The CIO of Barcelona City Council
Website full description	<a href="http://cityprotocol.org/meettheteam.html">http://cityprotocol.org/meettheteam.html</a>
Summary of activities	<p>City Protocol refers to both a program of activity and to the Society that is responsible to develop this system's approach to rationalize, under a shared basis, city transformation.</p> <p>The CP programme delivers agreements, in the form of information and recommendations, developed within the City Protocol Anatomy to address issues agreed by the community of cities. Typical deliverables are:</p> <p>Projects and policies tested in cities that can be used as exemplars for other cities, along with Indicators and certifications for those same projects and policies</p> <p>Recommendations and technological information.</p>
Comments	<p>The City Protocol Task Force brings together experts from a variety of backgrounds to tackle challenges identified by cities in an open and transparent way. The aim is to achieve allow rough consensus around these solutions so that they can gain widespread take up among the members of the City Protocol Society.</p> <p>All of the Intellectual Property used and generated within this process is managed by the City Protocol Society to ensure that it cannot be misused.</p> <p>These common solutions, effectively, become the precursor to city standards.</p>

#### Last updated

7 October 2014

## Abbreviations

3D	Three Dimensional
3GPP	3rd Generation Partnership Project
3GPP2	3rd Generation Partnership Project 2
6LoWPAN	IPv6 over Low power Wireless Personal Area Networks
AIM	Association for Automatic Identification and Mobility
ASCE	American Society of Civil Engineers
BIM	Building information modelling
CDMA	Code Division Multiple Access
CEN	Comité Européen de Normalisation
CENELEC	Comité Européen de Normalisation Electrotechnique
CITS	Collaboration on ITS Communication Standards
DMTF	Distributed Management Task Force
DWDM	Dense Wavelength Division Multiplexing
EMF	Electromagnetic Field
EPC	Electronic Product Code
EPON	Ethernet Passive Optical Network
ETSI	European Telecommunication Standards Institute
FDD	Frequency Division Duplex
GHG	Green House Gas
GIS	Geographic Information System
GML	Geography Markup Language
GPON	Gigabit Passive Optical Network
GPS	Global Positioning System
GS1	Globe Standard 1
GSM	Global System for Mobile Communications
HL7	Healthcare Level 7
IETF	Internet Engineering Task Force
ICT	Information and Communication Technologies
IT	Information Technology
IEC	International Electrotechnical Commission
IEEE	Institute of Electrical and Electronics Engineers
IoT	Internet of Things
ISO	International Organization for Standardization
ITS	Intelligent Transport System
ITU	International Telecommunication Union

ITU-T	International Telecommunication Union Standardization Sector
JTC	Joint Technical Committee
LTE	Long Term Evolution
M2M	Machine to Machine
OGC	Open Geospatial Consortium
OTN	Optical Transport Network
PC	Project Committee
PEV	Plug-in Electric Vehicle
RFID	Radio Frequency Identification
SAC	Standardization Administration of the People's Republic of China
SAG	Strategic Advisory Group
SC	Subcommittee
SDH	Synchronous Digital Hierarchy
SDO	Standards Development Organization
SEG	Systems Evaluation Group
SG	Study Group
SIGGRAPH	Special Interest Group for Computer GRAPHICS
SMB	Standardization Management Board
SOA	Service Oriented Architecture
SSC	Smart Sustainable Cities
SWM	Smart Water Management
TC	Technical Committee
TDD	Time Division Duplex
TMB	Technical Management Board
UNFCCC	United Nations Framework Convention on Climate Change
V2I	Vehicle to Infrastructure
V2V	Vehicle to Vehicle
V2X	Vehicle to Everything
W3C	World Wide Web Consortium
WCDMA	Wideband Code Division Multiple Access
WHO	World Health Organization
WP	Working Party
xDSL	x Digital Subscriber Line

## Bibliography

[b-FG-SSC infrastructure]	FG-SSC deliverable, <i>Technical Report on overview of smart sustainable cities infrastructure.</i>
[b-FG-SSC building]	FG-SSC deliverable, <i>Technical Report on smart sustainable buildings for smart sustainable cities.</i>
[b-FG-SSC data]	FG-SSC deliverable, <i>Technical Report on Anonymization Infrastructure and Open Data in Smart Sustainable Cities.</i>
[b-FG-SSC guide]	FG-SSC deliverable, <i>Technical Report on smart sustainable cities: a guide for city leaders</i>
[b-FG-SSC pipeline]	FG-SSC deliverable, <i>Technical Specifications on multi-service infrastructure for smart sustainable cities in new-development areas</i>
[b-ITU-T TR SSC Def]	<i>Technical Report on smart sustainable cities: an analysis of definitions (2014).</i>
[b-ITU-T TR overview]	<i>Technical Report on an overview of smart sustainable cities and the role of information and communication technologies (2014).</i>
[b-ITU-T TR water]	<i>Technical Report on smart water management in cities (2014).</i>
[b-ITU-T TR EMF Con]	<i>Technical Report on electromagnetic field (EMF) consideration in smart sustainable cities (2014).</i>
[b-ITU-T L.KPIs-overview]	<i>Technical Specifications on overview of key performance indicators in smart sustainable cities (2014).</i>
[b-ITU-T L.KPIs-ICT]	<i>Technical Specifications on key performance indicators related to the use of information and communication technology in smart sustainable cities.</i>
[b-ITU-T L.KPIs-impact]	<i>Technical Specifications on key performance indicators related to the sustainability impacts of information and communication technology in smart sustainable cities.</i>
[b-ITU-T L.KPIs-Supp]	<i>Technical Report on key performance indicators definitions for smart sustainable cities.</i>
[b-ITU-T TR roadmap]	<i>Technical Report on standardization roadmap for smart sustainable cities.</i>
[b-ITU-T TR management]	<i>Technical Report on integrated management for smart sustainable cities.</i>
[b-ITU-T TR climate]	<i>Technical Report on information and communication technologies for climate change adaptation in cities.</i>
[b-ITU-T TR security]	<i>Technical Report on cyber-security, data protection and cyber-resilience in smart sustainable cities.</i>
[b-ISO Focus+]	ISO Focus + (2014), <i>Smart Cities.</i>
[b-ISO/IEC JTC1 SG1 Report]	<i>Report on standardization needs for Smart Cities.</i>
[b-OGC Report]	Open Geospatial Consortium Report (2015), <i>OGC Smart Cities Spatial Information Framework.</i>
[b-SSCC-CG Report]	CEN/CENELEC/ETSI SSCC-CG, <i>Final report and recommendations of SSCC-CG.</i>





OPPORTUNITY  
AHEAD



OPPORTUNITY









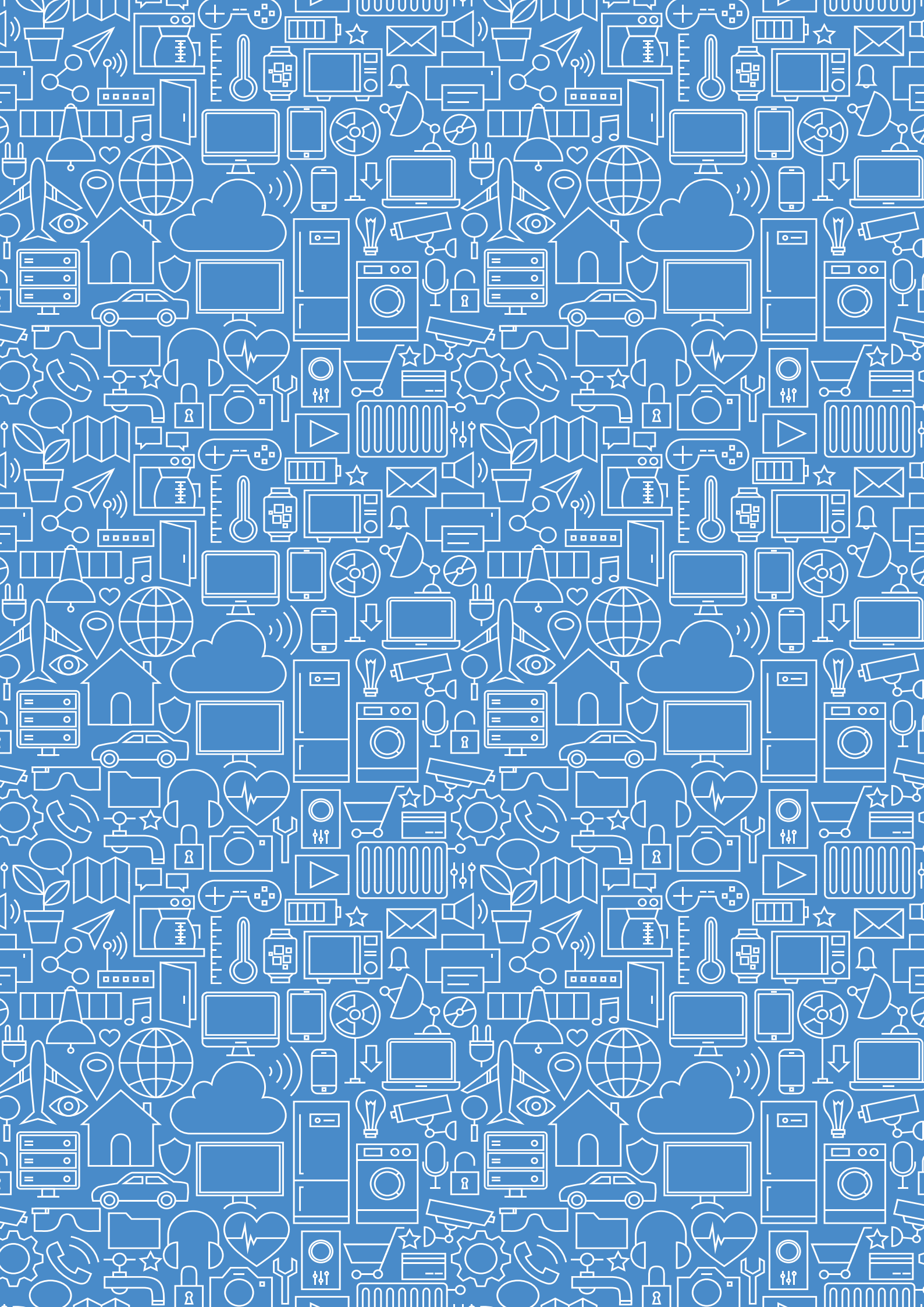
# CONCLUSION

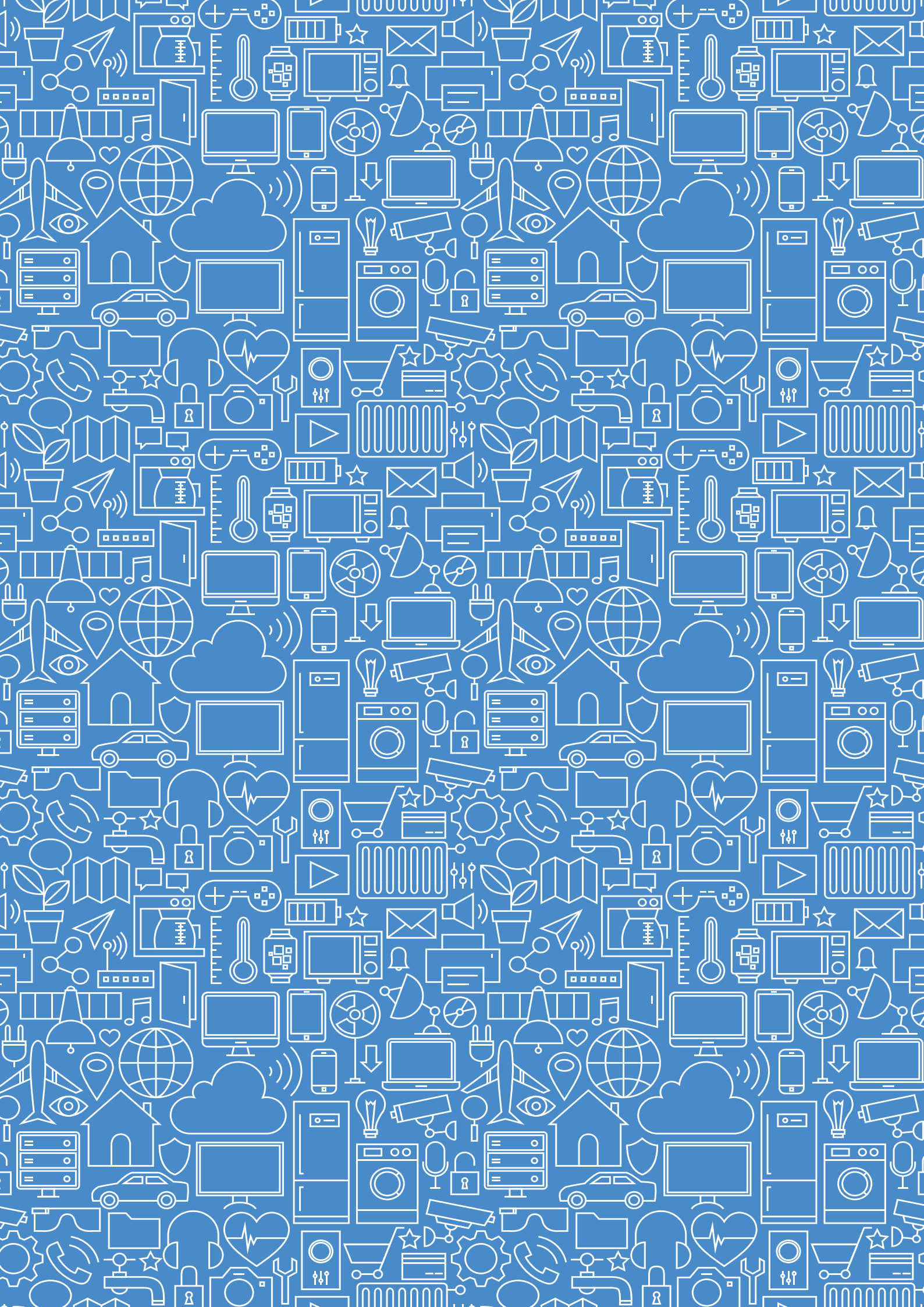
ITU aims to assist urban administrations in their journey towards becoming “smart” and “sustainable”. ITU’s work to build greater understanding of the functionality of Smart Sustainable Cities is an essential part of this assistance.

A Smart Sustainable City is an intricate, multi-layered system. An urban administration’s commitment to develop a Smart Sustainable City should be supported by an in-depth understanding of their composition and functionality. This in-depth understanding is crucial to the formulation of a long-term vision for the development of a Smart Sustainable City, as well as a strategy to guide stakeholders towards the realization of that vision.

This compendium will help urban administrations to gain the in-depth understanding necessary to the formulation of a vision and supporting strategy for the development of a Smart Sustainable City. ITU has also strengthened its commitment to assist cities in their transformations into Smart Sustainable Cities by offering them the required support on a city-by-city basis.

It is ITU’s hope that this compendium of Technical Reports and Specifications will help cities to commence their transformations into Smart Sustainable Cities, and we encourage all smart-city stakeholders to follow or participate in the work of ITU-T Study Group 20, a group with considerable influence in shaping technical priorities for Smart Sustainable Cities.





International  
Telecommunication  
Union

Place des Nations  
CH-1211 Geneva 20  
Switzerland

ISBN 978-92-61-16451-5



9 789261 164515

Printed in Switzerland  
Geneva, 2016

Photo credits: Shutterstock