

ACCESSIBILITY OF HOUSING

A HANDBOOK OF INCLUSIVE
AFFORDABLE HOUSING
SOLUTIONS FOR **PERSONS
WITH DISABILITIES
AND OLDER PERSONS**



ACCESSIBILITY OF HOUSING

A HANDBOOK OF INCLUSIVE
AFFORDABLE HOUSING
SOLUTIONS FOR **PERSONS
WITH DISABILITIES
AND OLDER PERSONS**

UN  HABITAT



ACCESSIBILITY OF HOUSING: A HANDBOOK OF INCLUSIVE AFFORDABLE HOUSING
SOLUTIONS FOR PERSONS WITH DISABILITIES AND OLDER PERSONS

All rights reserved

First published in Nairobi in 2014 by UN-Habitat.
Copyright © United Nations Human Settlements Programme 2014
United Nations Human Settlements Programme (UN-Habitat)
P. O. Box 30030, 00100 Nairobi GPO KENYA
Tel: 254-020-7623120 (Central Office)
www.unhabitat.org

HS/058/14E

ISBN(Volume): 978-92-1-132635-2

Disclaimer:

The designations employed and the presentation of the material in this guide do not imply the expression of any opinion whatsoever on the part of Secretariat of the United Nations concerning the legal status of any country, territory, city or area of its authorities, or concerning the delimitation of its frontiers or boundaries. Views expressed in this publication do not necessarily reflect those of the United Nations Human Settlements Programme, the United Nations, or United Nations Member States.

Acknowledgements:

Supervisor: Christophe Lalande
Task manager: Emma-Liisa Hannula
Principal author: Marja Edelman
Co-author: Ana Carolina Moreira Pudenzi
Design and layout: Andrew Ondoo
Editor:
Contributors: Christophe Lalande, Emma-Liisa Hannula, Fernanda Lonardoni, Gregor Herda (UN-Habitat), Bahram Ghazi, Krista Orama, Facundo Chávez Penillas (Office of the High Commissioner for Human Rights – OHCHR), Antje Ilberg, Andrea Viviana Cifuentes, Aurora Gomes Ferreira Aragão Santos, Cristian Martinez, Denis Green, Eliane Pereira, Victor Ribeiro Monteiro, Elisabete França, Francis Musoni, Harald Hinkel, Isabel Cristina Joventino de Deus, Jia Chen Xie, Jonathas Magalhães, Kester Yim, Lillian Nagato, Lucy Zhang, Márcia Maria Braga Rocha Muniz, Marcos Boldarini, Michael Beaman, Marly Anne Bacaron, Michel Silva de Oliveira, Natacha Lemasle, Nestor Fernando Lopez, Rayna Razmilic, Rachel Zhao, Renata Gomes, Susana Rojas Williams, Rodrigo Moraes, Peggy Mesner, Sukumaporn Jongpukdee, Yanyong Boon-Long, Yutaka Sho, Zeba Vanek, Zaneta Hong.
Drawings: Renata Gomes
Cover pictures: Woman in wheelchair in Pakistan ©PAKSABAB, Social Housing in Sao Paulo, Brazil ©Daniel Ducci and Ex-combatant in wheelchair, Man in wheelchair in Rwanda ©Harald Hinkel/World Bank
Printer:



Table of contents

01	INTRODUCTION	2
	Background of the handbook	2
	Context	3
	Goal of the handbook	3
	Understanding disability in the built environment	6
02	KEY ISSUES AND CONCEPTS OF ACCESSIBLE AFFORDABLE HOUSING	6
	Aging and impairments	8
	Universal design	8
	Inclusive environments	10
	Sustainable Development, Accessibility and Poverty	10
03	EXISTING INTERNATIONAL TECHNICAL AND NORMATIVE FRAMEWORK TO SUPPORT SUSTAINABLE ACCESSIBILITY OF AFFORDABLE HOUSING	14
	Context	14
	Building codes and other standards supporting accessibility	15
	Participatory processes	15
04	TECHNICAL GUIDELINES TO SUPPORT ACCESSIBLE AFFORDABLE HOUSING	24
	Design Recommendations: Urban Environment and Public Spaces	27
	Design Recommendations: Housing Units	34
	Accessible routes	45
05	CASE STUDIES	50
	Context 1: Slum Upgrading	50
	Context 2: Large Scale Affordable Housing / Social Housing	54
	Context 3: Reconstruction	63
	Accessibility of Older Persons	68
06	GAP ANALYSIS	76
07	KEY FINDINGS AND RECOMMENDATIONS	80
	FURTHER READING/REFERENCES	83
	BIBLIOGRAPHY	84
	ANNEX 1: CHECKLISTS	87
	Checklist accessible routes	87
	Checklist housing units	89



LIST OF BOXES

Box 1: Universal design and Post 2015 agenda	9
Box 2: Four sides of sustainable housing.....	11
Box 3: Rights Based Approach to Participation	16
Box 4: Right to Adequate Housing	17

LIST OF FIGURES

Figure 1: Home for older persons in Chaimai Province, Thailand	25
Figure 2: Anthropometrics	27
Figure 3: Street furniture view	28
Figure 4: Street furniture plan.....	29
Figure 5: Traffic lights with audible and visual signal.....	29
Figure 6: Tactile warning and directional floor	30
Figure 7: Applications of tactile floor.....	31
Figure 8: Examples of curb ramps	31
Figure 9: Curb ramp with warning and directional tactile signage in, Brasilia, Brazil	32
Figure 10: Elevated pedestrian crossing, Brasilia, Brazil.....	32
Figure 11: Parking spaces.....	33
Figure 12: Key elements of an accessible route.....	34
Figure 13: Accessible route.....	35
Figure 14: Ramped access options in elevated house.....	35
Figure 15: Ramped access.....	36
Figure 16: Ramps for constant (A1) and frequent (B1) two-way traffic.....	38
Figure 17: Elevators	39
Figure 18: Lifting platform.....	39
Figure 19: Railings and handrails.....	40
Figure 20: Preferred handrails	41
Figure 21: Door handle	41
Figure 22: Turning space in corridors.....	41
Figure 23: Bedroom with bathroom	42
Figure 24: Working surfaces, e.g. kitchen sink	42
Figure 25: Operable windows	43
Figure 26: Restrooms with clear circumscribed manoeuvring area	44
Figure 27: Wooden seat with collection bin and grab bars	44
Figure 28: Alternative wooden grab bars.....	45



Figure 29: Dry flat toilets on elevated wooden floor.....45

Figure 30: Accessible routes and pedestrian crossings46

Figure 31: Elevated pathways.....47

Figure 32: Pedestrian flows and accessible routes.....48

Figure 33: (A) Bus stop and pathway signalized with tactile directional floor: as design and built situations.....49

Figure 34: (B) Pedestrian crossing.....49

Figure 35: Elevated pathway, Rocinha, Brazil.....51

Figure 36: Street 4 before and after the upgrading process, Rocinha, Brazil.52

Figure 37: Metrocable, Medellin, Colombia54

Figure 38: Escalators in “Comuna 13”54

Figure 39: Barrier free washrooms56

Figure 40: Low window and external door with glazing to allow view from wheelchair57

Figure 41: Accessible apartment, plan.....58

Figure 42: Schematic drawing with ramps and staircases.....59

Figure 43: Ramps and street view60

Figure 44: Earth bag construction.....62

Figure 45: Masoro House 162

Figure 46: Masoro House 2: A bridge connects the two-story building to the upper portion of the site.....62

Figure 47: Noor Jehan house, (exposed straw bale under plaster).....64

Figure 48: Noor Jehan house, (ramped access under construction)64

Figure 49: Saadia Noor house, (adapted kitchen).....65

Figure 50: Kulsoom Bibi house, (adapted bathroom).....65

Figure 51: Different phases of incremental housing67

Figure 52: Ground floor plan-adapted units with accessible ground floor.....68

Figure 53: Adapted houses with SHW systems.....68

Figure 54: Typical residential building in Baan Eua Ar-thorn. Ramps and handrails were provided in every building.....69

Figure 55: (Left) Adapted toilet in Chiang Mai province70

Figure 56: (Right) Toilet improvement with handrails and bath chair.....70

Figure 57: Flat toilet and bath chair provision with handrails71

Figure 58: Proposed improvements to Ms. FEI Lanying house, in Yichuan Community in Putuo District, Shangha73

Figure 59: Bathroom with upgraded facilities including a grab-bar for accessibility74

LIST OF TABLE

Table 1: Disability prevalence rates for thresholds 40 derived from multi domain functioning levels in 59 countries.12

CHAPTER

01

Introduction

The chapter presents and contextualizes the publication under the framework of the Global Network for Sustainable Housing (GNSH); outlining the main issues addressed, target audience and goals of the handbook.

Background of the handbook

This publication is part of the activities of the Global Network for Sustainable Housing (GNSH) managed by the UN-Habitat Housing Unit. The GNSH has been created to contribute to the development of sustainable and affordable housing solutions in developing countries and emerging economies. The GNSH has a specific focus on improving the social, cultural, economic and environmental sustainability of slum upgrading, reconstruction, large-scale affordable housing and social housing programmes.

The handbook presents practical solutions to outgrow accessibility barriers for persons with disabilities and older persons in the contexts of slum upgrading, reconstruction, large-scale affordable and social housing programmes. It provides technical guidelines and best practices for policymakers, local authorities, urban planning and construction/housing practitioners in the private and public sectors and the staff of international and local humanitarian organizations and development agencies. The handbook works as a communication tool to raise awareness regarding the accessibility of affordable sustainable housing sector.

Context

Everyone is susceptible to being physically restricted at some point of their lives¹. From childhood to old age, circumstances that limit people's possibilities to move may arrive at any time: a pregnancy, a broken leg or walking with a pram, for example, are common situations of limited movement.

Furthermore, low-income groups are often settled in scarcely urbanized areas, landfills, segregated spaces disconnected from adequate urban infrastructure or often in areas with high disaster risk such as mountain slopes with landslides menace, flooding, earthquake or tsunami prone zones. These areas normally present problems with drainage, open sewers, lack of public lighting and signalling, unpaved and narrow paths, irregular surfaces and no sidewalks. Under these circumstances, housing is frequently built informally or inadequately, below any minimum building standards, made of inappropriate building materials that do not create permanent housing conditions.²

The hurdles mentioned above are determinant factors to decrease autonomy and quality of life of older persons and persons with disabilities. Limited or no access to public spaces, transportation, education, health and even the dignified use of housing facilities reaffirms the poverty condition of these vulnerable groups, turning sustainable development into an unreachable goal.

¹ (United Nations, Department of Economic and Social Affairs (UNDESA) Division for Social Policy and Development, 2004)

² (Fillipi, 2008)

This handbook addresses the main question of how to reach feasible and practical solutions, minimizing the problems faced by older persons and persons with disabilities under the contexts presented here.



Goal of the handbook

Being able to access adequate housing is a human right for everyone as stated in Article 25 of the Universal Declaration of Human Rights³, Article 11 of the International Covenant on Economic, Social and Cultural Rights⁴, the Convention on the Rights of Persons with Disabilities (CRPD)⁵ and in the Habitat Agenda. Financial access to housing for low-income urban dwellers including poor persons with disabilities and older persons should be made easier. Poor households invest a major portion of their income into housing. Therefore, being able to remain in the same house when reaching old age or after acquiring an impairment should be facilitated.

³ UN General Assembly, *Universal Declaration of Human Rights*, 10 December 1948, 217 A (III), available at: <http://www.un.org/en/documents/udhr/> [accessed 22/05/2014]

⁴ UN General Assembly, *International Covenant on Economic, Social and Cultural Rights*, 16 December 1966, United Nations, *Treaty Series*, vol. 993, p. 3, available at: <http://www.ohchr.org/en/hrbodies/cescr/pages/cescrindex.aspx> [accessed 25 July 2014]

⁵ UN General Assembly, *Convention on the Rights of Persons with Disabilities*, 13 December 2006, available at: <http://www.un.org/disabilities/default.asp?navid=15&pid=150> [accessed 26 January 2014]



From the perspective of sustainability, accessibility links three primary aspects: social, through equity; economic, via financial independence; and environmental, as when housing projects and programmes adopt green low-cost strategies for spatial adaptation. Spatial inclusion enables social inclusion for the person with disabilities and his/her family. Accessibility leads to independence, increased mobility, access to the labour market and consequently a better quality of life.

This handbook aims to bridge the existing gap between the needs and rights of persons with disabilities and older persons with slum upgrading, reconstruction, large-scale affordable and social housing programmes. Through the provision of concepts, major policy approaches, practical information and technical tools, the handbook intends to build capacity regarding designing and implementing accessibility in identified contexts. Likewise, it brings into light the implication and the global importance of developing accessibility of sustainable human settlements.



CHAPTER

02

Key issues and concepts of accessible affordable housing

This chapter presents key concepts to achieve sustainability including accessibility in the contexts of slum upgrading, reconstruction and affordable housing programmes. It gives a brief historical background to the evolution of the concept of disability and its relation with society and the environment. In conclusion, the chapter illustrates how accessibility has the potential to reduce poverty and therefore contribute to sustainability.

Understanding disability in the built environment

Concept of disability

The United Nations Convention on the Rights of Persons with Disabilities (CRPD) does not provide for a static definition of “disability”. It says that disability is an evolving concept and that disability results from the interaction between persons with impairments and attitudinal and environmental barriers that hinders their full and effective participation in society. The Convention establishes new, legally binding standards and concepts related to the rights of persons with disabilities. It has gained wide international support and recognition through ratification by a vast majority of countries across the world.⁶ In accordance with the Convention’s concept of disability, “persons with disabilities” include those who have long-term physical, mental, intellectual or sensory impairments, which in interaction with various barriers may hinder their participation in

⁶ By 13 August 2014, the Convention had been ratified by 146 States and the European Union. For updated information on the status of ratifications, please see <https://treaties.un.org/Pages/Treaties.aspx?id=4>.



society on an equal basis with others. As such, physical obstructions of the built-up environment constitute a disability to a person with a physical impairment.⁷

From exclusivity to a human rights paradigm shift

In the beginning of the 20th century, disability was exclusively seen as a health condition. The paradigm started to shift when human rights approaches unveiled that persons with disabilities should not be discriminated against on the basis of disability, but integrated in the society as equal members. Nowadays, concepts and discussions focus on inclusion, and “medically-focused solutions have given way to more interactive approaches.”⁸ The human rights-based approach to disability acknowledges persons with disabilities as subjects of rights and the State and others as having responsibilities to respect, protect and fulfil the rights of these persons. It treats the barriers in society as discriminatory and provides an avenue to remove these barriers and to include persons with disabilities as equal members of society.⁹

Barrier free design, accessibility and universal design

Efforts aiming at a paradigm shift began in the late 1950s, when the term *barrier-free design* started to be used. The idea was to remove barriers for “persons

with disabilities” from the built environment. It was later replaced with the term *accessibility*, which in many countries focused on issues of mobility, such as wheelchair access. *Universal design* was first used and promoted in the United States in 1985 to communicate a design approach that could be used by a wider range of people.¹⁰ As further detailed below, the concepts of accessibility and universal design have been anchored as universally accepted standards in the Convention on the Rights of Persons with Disabilities.

The United Nations Convention on the Rights of Persons with Disabilities, ratified by 145 countries, acknowledges **accessibility** as one its crosscutting general principles relevant for the realisation of all other rights enshrined in the Convention (article 3). It further has a stand-alone article on accessibility (article 9), which demands States parties to take appropriate measures to ensure to persons with disabilities access, on an equal basis with others, to the physical environment, to transportation, to information and communication, including information and communication technologies and systems, and to other facilities and services open or provided to the public, both in urban and rural areas. These measures, which shall include the identification and elimination of obstacles and barriers to accessibility, shall apply to, inter alia:

- Buildings, roads, transportation and other indoor and outdoor facilities, including schools, housing, medical facilities and workplaces;
- Information, communications and other services, including electronic services and emergency services.

⁷ (Convention on the Rights of Persons with Disabilities, 2006, preamble paragraph (e) and article 1(2). The Convention and its Optional Protocol were adopted on 13 December 2006 at the United Nations Headquarters in New York, and was opened for signature on 30 March 2007. They entered into force on 3 May 2008.)

⁸ (World Health Organization and World Bank, 2011)

⁹ (Office of the United Nations High Commissioner for Human Rights, *The Convention on the Rights of Persons with Disabilities. Training Guide. Professional Training Series No. 19.* New York and Geneva 2014)

¹⁰ (Wolfgang F. E. Preiser, 2010)

The issue of slums and accessibility

In the context of slum upgrading and affordable housing the issue has not yet been properly addressed. As slums typically do not follow regulations and building codes, it is extremely challenging to adapt the built environment to the needs of persons with disabilities. Therefore, efforts have concentrated on the accessibility of routes, on basic services such as water and electricity as well as connecting existing slums to public transportation. Social housing/affordable housing programmes present a better situation as these programmes are often governmental and must comply with building codes, regulations and national minimum standards of adequacy related to accessibility.

Aging and impairments

The number of persons aged 60 and over is increasing at an unprecedented pace globally, anticipated to rise from its current 740 million to reach 1 billion by the end of the decade. Today, two-thirds of the world's older persons population live in low-and middle-income countries and this proportion will rise to 80 per cent by the year 2050¹¹.

At the same time, more people who have acquired physical or mental impairments earlier in life are living longer, resulting in growing numbers of persons with disabilities reaching old age.

Although old age does not necessarily entail acquiring an impairment, a significant proportion of people reaching old age will experience physical or sensory limitations, which will compromise their independence. Some impairments, such as hearing and vision loss or osteoporosis, may occur

¹¹ UN Office of the High Commissioner of Human Rights

naturally as a part of the aging process and reduce mobility and agility¹².

The number of persons with disabilities tends to grow due to demographic changes (e.g. aging of the population), especially in poverty conditions, where health care provision is lacking. This means that in slums more adaptable housing as well as more accessible routes and facilities will be needed in the near future.

Universal design

As defined in Article 2 of the Convention on the Rights of Persons with Disabilities (CRPD) ¹³ “Universal design” is “the design of products, environments, programmes and services to be usable by all people, to the greatest extent possible, without the need for adaptation or specialized design. Universal design shall not exclude assistive devices for particular groups of persons with disabilities where this is needed.”

The concept enfold seven-principles, developed in 1997¹⁴ to deliver designs for the built environment and products to be used by as many persons as possible. However, it is not synonymous with a single design being appropriate for all situations and circumstances. According to the United Nations Economic and Social Commission for Western Asia (ESCWA), “Universal designs are not entirely about accessibility but about the appropriateness

¹² HelpAge International, 2004

¹³ UN General Assembly, Convention on the Rights of Persons with Disabilities, 13 December 2006, available at: <http://www.un.org/disabilities/default.asp?id=262> [accessed 26 January 2014]

¹⁴ The seven Principles of Universal Design were developed in 1997 by the Center for Universal Design with a group of U.S. experts and articulated a process by which to define and evaluate the usability of design elements.

of design solutions to gender, the demographic group and to the social and economic setting.”¹⁵

The seven Principles of Universal Design are presented as follows¹⁶:

1. **Equitable use** - the design is useful and relevant to a wide group of users;
2. **Flexibility in use** - the design accommodates a wide range of individual preferences and abilities;
3. **Simple and intuitive use** - the design is easy to understand regardless of the knowledge, experience, language skills or concentration level of the user;
4. **Perceptive information** - the design communicates information effectively to the user regardless of the ambient condition or the sensory abilities of the user;
5. **Tolerance for error** - the design minimizes the hazards and adverse consequences of unintended actions of the user;
6. **Low physical effort** - the design can be used easily, efficiently and comfortably with a minimum of fatigue; and
7. **Size and space for approach and use** - the size and space for approach, reach, manipulation and use should be appropriate regardless of the body size, posture or mobility of the user.

“Universal design is mentioned in the context of formulating a sustainable development agenda beyond 2015 (Box 1) as a way to address accessibility. The concept is also mentioned by the United Nations Economic Commission for Europe – UNECE, to be used to “improve the access of persons with disabilities to barrier-free housing”.¹⁷ Universal design principles, when properly interpreted, can be a solution for low-cost projects as its main concept is to adapt the design to all users. Therefore, every project can be re-thought under this perspective, the same way low-cost solutions are created to attend to a population’s needs with small budgets. Universal design provides infinity of possibilities as it allows the use of innovative solutions provided by professionals involved in the process. It is important to notice, however, that some disabilities require more elaborated strategies and occasionally the use of accessories (lifts, grab bars, lighting or acoustical signs etc.) than others, as shown in Chapter 4.

BOX 1: UNIVERSAL DESIGN AND POST 2015 AGENDA

The report of United Nations Secretary-General “The way forward: a disability-inclusive development agenda towards 2015 and beyond” endorses the use of universal design principles, as stated: “Accessibility should be a central consideration in the emerging post-2015 development agenda, and regarded as an essential investment for sustainable development, advancing accessibility and the progressive removal of barriers to the physical environment, transportation and information and communications, incorporating the principle of universal design.”¹⁸

¹⁵ ESCWA, 1999

¹⁶ Wolfgang F. E. Preiser, 2010

¹⁷ United Nations Economic Commission for Europe (UNECE), 2013

¹⁸ UN General Assembly, 2013



Inclusive environments

Environments may impose barriers or enable people with impairments, directly affecting their participation and inclusion in society. To succeed, accessibility initiatives need to take into account external constraints including affordability, competing priorities, availability of technology and knowledge, and cultural differences.¹⁹

An inclusive environment recognises and accommodates differences in the way people use the built environment and provides solutions that enable all users (regardless of age, gender or disability) to participate in activities equally, independently, with choice and with dignity. Inclusive environments consider people's diversity and break down unnecessary barriers and exclusions in a manner that benefits all²⁰.

Slums and their inhabitants have historically faced exclusion from urban infrastructure and access to social, health and educational services. When developing or implementing slum-upgrading programmes, there is an opportunity to adopt creative solutions, propose alternative accessible routes and open spaces and create a more inclusive environment, instead of surrendering to the challenge of budget constraints.

Sustainable development, accessibility and poverty

Vulnerability and disability

Sustainable development is a multidimensional process that connects the four primary aspects of sustainability: cultural, economic, environmental,

and social²¹. In order to achieve sustainable human settlements, adequate provision for basic needs such as affordable housing is indispensable and issues such as poverty and inequalities related to vulnerabilities such as gender and disability should be addressed.

According to the *World Health Survey* data from 2004, across all countries, vulnerable groups such as women, those in the poorest wealth quintile, and older persons have higher prevalence of disability. As seen in Table 1, the prevalence of disability in lower income countries among people aged 60 years and above is 43.4 per cent, compared with 29.5 per cent in higher income countries.²² This vulnerability, exponentially increased by the built environment, can and must be avoided.

Inclusive human settlements development

Human settlements should be socially enhancing and environmentally friendly. To apply a sustainable approach to human settlements, it is important to establish goals, set priorities and preconditions, aiming at a balanced association between all dimensions.²³

Moreover, sustainable housing (Box 2) generates permanent improvement in the quality of life of the people involved²⁴. To achieve this, construction strategies may differ in context and content from region to region and therefore, must be addressed locally²⁵.

²¹ UN-Habitat, 2012

²² World Health Organization and World Bank, 2011

²³ UN-Habitat, 2012

²⁴ Ivo Imparato, 2003

²⁵ International Organization for Standardization ISO, 2008

¹⁹ World Health Organization and World Bank, 2011
²⁰ Fleck, 2006



The inclusion of solutions of accessibility in the built environment through universal design allows better mobility, a higher level of independence and self-esteem. It increases possibilities of participation in community life, from social activities to decision-making processes. Additionally, accessibility in the contexts discussed in this handbook also means the

possibility of income generation through economic activities provided by the inclusion of persons with disabilities in the economic market which in turn leads to the reduction of poverty and vulnerability. Accessibility leads to a healthier and more equal environment.

BOX 2: FOUR SIDES OF SUSTAINABLE HOUSING

1. **Cultural** sustainability takes into consideration cultural worldviews and values, norms and traditions, as well as lifestyles and behaviours of occupants, communities and society. For many communities, housing represents much more than an asset: it has an historic, aesthetic, spiritual or cultural value. Maintaining and protecting heritage of different groups in a society supports the dignity of communal life, enhancing equity and helping to maintain peace and stability.
2. The **economic** dimension of housing sustainability, on the other hand, arises from the fact that housing is indeed a capital asset. It is an important part of household and public expenditure. Construction, services and real estate markets are some of the key economic and employment activities, including home-based activities and entrepreneurship. Decent affordable housing and infrastructure is key to sustainable economic development at the local level, as it makes places more attractive, inclusive and competitive.
3. **Environmental** sustainability of housing is concerned with the impacts of housing on the environment and climate change, and vice versa. It means balancing multiple matters and choices: designing with the local climate, prioritizing natural or recycled materials and its availability (manufacturing and transportation), connecting housing with sustainable energy provision and avoiding poisons and pollutants, among others.
4. **Social** sustainability in housing relates to the integration of housing, residential areas and communities into urban and national socio-spatial systems. Moreover, social sustainability is achieved through affordable and good quality housing in secure and healthy dwellings, as part of an inclusive and diverse (mixed-tenure and mixed-income) community.

Source: UN-Habitat. (2012). *Sustainable Housing for Sustainable Cities, A Policy Framework for Developing Countries*. United Nations Human Settlements Programme. Nairobi: UN-Habitat.
UN-Habitat. (2012). *Going Green , A Handbook of Sustainable Housing Practices in Developing Countries*. United Nations Humans Settlements Programme. Nairobi: UN-Habitat.

TABLE 1: DISABILITY PREVALENCE RATES FOR THRESHOLDS 40 DERIVED FROM MULTI DOMAIN FUNCTIONING LEVELS IN 59 COUNTRIES.

Population subgroup	Higher income countries (%)	Lower income countries (%)	All countries (%)
Sex			
Male	9.1	13.8	12.0
Female	14.4	22.1	19.2
Age group			
18-49	6.4	10.4	8.9
50-59	15.9	23.4	20.6
60 and over	29.5	43.4	38.1
Place of residence			
Urban	11.3	16.5	14.6
Rural	12.3	18.6	16.4
Wealth quintile			
Q1 (poorest)	17.6	22.4	20.7
Q2	13.2	19.7	17.4
Q3	11.6	18.3	15.9
Q4	8.8	16.2	13.6
Q5 (richest)	6.5	13.3	11.0
Total	11.8	18.0	15.6

Adapted from: World Health Survey. Geneva, World Health Organization, 2002–2004



CHAPTER

03

Existing international technical and normative framework to support sustainable accessibility of affordable housing

This chapter aims to give the reader an overview of existing supporting standards and guidelines to achieve an integrated approach to accessibility and sustainability in slum upgrading, social housing and reconstruction programmes. A priori, existing national and local regulations must be observed and used in conjunction.

Context

A Global Survey on “Government Action on the Implementation of the Standard Rules on the Equalization of Opportunities for Persons with Disabilities”²⁶, was conducted between the years 2004 and 2005 in each of the 191 Member States of the United Nations by the World Health Organization. Based on responses of 114 countries²⁷, the survey found that 54 per cent of the countries did not have accessibility standards for outdoor environments and streets, 43 per cent for public buildings, and 44 per cent for schools, health facilities, and other public service buildings. Moreover, 65 per cent had not started any educational programmes, and 58 per cent had not allocated any financial resources to increase accessibility.

Although there is a normative framework addressing slum upgrading and social housing policies at international level, there is a clear lack of operationalization and implementation, especially in developing countries. Normally, slum upgrading and social housing programmes

²⁶ South-North Center for Dialogue & Development, for the Office of the UN Special Rapporteur on Disabilities, , 2006

²⁷ Responses were obtained from each region as follows: 23 countries in Africa, 21 countries in Asia, 30 countries in Europe, 21 countries in Latin America, 19 countries from Arab States. Two responses were obtained from Hong Kong and Palestine.



are response-driven by local contexts and issues, reflecting an attempt to follow and adapt municipal directives under a broader umbrella that includes building codes, urban planning and other specific regulations (e.g. accessibility). It is more likely to find social and affordable housing construction standards or guidelines developed both at national and municipal levels (see example in Box 5). In the case of slums, their contexts and conditions may vary so much that each slum has to be assessed and approached individually. Slum residents have the best knowledge of how their settlements work, the characteristics of their communities and the nature of their needs and priorities²⁸.

Building codes and other standards supporting accessibility

Mandatory minimum standards, enforced through national legislation, are required to remove barriers to accessibility in the built environment. An integrated approach to standards is key to improve accessibility, particularly in the contexts of sustainable slum upgrading, reconstruction, and affordable and social housing programmes. Multidisciplinary groups are crucial when developing and implementing an accessible and sustainable programme, as different backgrounds are more likely to encompass all relevant aspects of accessibility, sustainability, functionality, economy, efficiency and equity.

28 (UN-Habitat, 2011)

Participatory processes

Participatory processes have the potential to avoid public opposition and prevent marginalization. It also addresses project sustainability and efficiency.²⁹

In parallel, participatory decision-making processes as consultative workshops with local community are likewise essential, particularly involving persons with disabilities. As they have first-hand knowledge of their situation and the barriers they face, when formulating and implementing policies and programmes, persons with disabilities should be consulted and actively involved. States parties to the Convention on the Rights of Persons with Disabilities have agreed to closely consult with and actively involve persons with disabilities, through their representative organizations, in the development and implementation of legislation and policies to implement the Convention and in other decision-making processes concerning issues relating to persons with disabilities.³⁰ Importantly, organizations of persons with disabilities may need capacity building and support to empower them and advocate for their needs.³¹ Box 3 highlights the five major steps to incorporate participants according to human rights based framework principles of participation.

29 (The Global Initiative for Economic, Social and Cultural Rights, 2014)

30 Article 4(3) of the Convention on the Rights of Persons with Disabilities.

31 (World Health Organization and World Bank, 2011)

BOX 3: RIGHTS BASED APPROACH TO PARTICIPATION³²

As recognized by the Common Understanding on a Human Rights-Based Approach³³, “all programmes of development co-operation, policies and technical assistance should further the realisation of human rights as laid down in the Universal Declaration of Human Rights and other international human rights instruments.”

Among the human rights principles which guide all programming in all phases of the programming process, it is important to highlight universality and inalienability; indivisibility; inter-dependence and inter-relatedness; non-discrimination and equality; participation and inclusion; accountability and the rule of law.

To fully address participation, “Free, Prior and Informed Consent (FPIC)” is a crucial concept to be respected. Under this concept, populations are free from coercion or manipulation, are involved in decision making before plans are made, have the technical and legal knowledge required to make decisions, and ultimately reserve the right to withhold consent.

To incorporate participants according to human rights based framework principles of participation; it is recommended to follow five steps:

1. Conducting a Stakeholder Analysis,
2. Conducting a Knowledge/Capacity Assessment,
3. Informing local participants,
4. Obtaining consent in accordance with FPIC standards,
5. Involving participants in the planning, implementation and evaluation of the project.

The standards, conventions and guidelines described below have been developed, agreed and established by interested bodies such as the United Nations, the International Organization for Standardization (ISO), the Red Cross, etc. The list does not intend to be exhaustive, but merely illustrative of the existing technical and normative support on three specific topics: Accessibility, Sustainability and Development and Reconstruction.

International Norms

- **Universal Declaration of Human Rights³⁴** (Adopted by the General Assembly of the United Nations on 10 December 1948). The declaration is “a common standard of achievement for all peoples and all nations, to the end that every individual and every organ of society, keeping this Declaration constantly in mind, shall strive by teaching and education to promote respect for these rights and freedoms and by progressive measures, national and international, to secure their universal and effective recognition and observance, both among the peoples of Member States themselves and among the peoples of territories under their jurisdiction.” In its article 25 the declaration states that everyone has the right of an adequate standard of living, including housing.

³² *(The Global Initiative for Economic, Social and Cultural Rights , 2014)*

³³ *The_Human_Rights_Based_Approach_to_Development_Cooperation_Towards_a_Common_Understanding_among_UN*. Available at: [http://www.undg.org/archive_docs/6959-\[accessed 25 July 2014\]](http://www.undg.org/archive_docs/6959-[accessed 25 July 2014])

³⁴ *Universal Declaration of Human Rights*, available at: <http://www.un.org/en/documents/udhr/> [accessed 26 July 2014]

- **International Covenant on Economic, Social and Cultural Rights**³⁵ (Adopted and by General Assembly on 16 December 1966, entry into force 3 January 1976). In its Article 11, the Covenant highlights that the States Parties, recognizing the importance of international cooperation and free consent, will take appropriate steps to ensure the realization of the right of an adequate standard of living, including housing.
- **General Comment 4 of the Committee on Economic, Social and Cultural Rights**³⁶ (Published on 13 December 1991). The Comment stresses the importance of the human right to adequate housing, derived from the right to an adequate standard of living. Article 6 sustains that “the right to adequate housing applies for everyone”. Article 8 supports the “full and sustainable access to adequate housing resources” to disadvantaged groups³⁷. It states that housing law and policy should consider specific housing needs for these groups and some degree of priority consideration in regards to housing should be granted.

Box 04 provides information on the right to adequate housing and the concept of adequacy.

³⁵ *International Covenant on Economic, Social and Cultural Rights*, available at: (Office of the)

³⁶ *UN Committee on Economic, Social and Cultural Rights (CESCR), General Comment No. 4: The Right to Adequate Housing (Art. 11 (1) of the Covenant), 13 December 1991, E/1992/23*, available at: <http://www.refworld.org/docid/47a7079a1.html> [accessed 26 July 2014]

³⁷ According to the General comment No. 4, disadvantaged groups makes reference to “the elderly, children, the physically disabled, the terminally ill, HIV-positive individuals, persons with persistent medical problems, the mentally ill, victims of natural disasters, people living in disaster-prone areas and other groups.”

BOX 4: RIGHT TO ADEQUATE HOUSING

What is the right to adequate housing?

The right to adequate housing means that each and every person has the right to live somewhere in security, peace and dignity.

What does adequacy in housing include?

- **Legal security of tenure:** Regardless of the type of tenure, all persons should possess a degree of security of tenure which guarantees legal protection against forced eviction, harassment and other threats;
- **Affordability:** Personal or household financial costs associated with housing should not threaten or compromise the attainment and satisfaction of other basic needs (for example, food, education, access to health care);
- **Habitability:** Adequate housing should provide for elements such as adequate space, protection from cold, damp, heat, rain, wind or other threats to health, structural hazards, and disease vectors;
- **Availability of services, materials, facilities and infrastructure:** Housing is not adequate if its occupants do not have safe drinking water, adequate sanitation, energy for cooking, heating and lighting, sanitation and washing facilities, means of food storage, refuse disposal, etc.;
- **Accessibility:** Housing is not adequate if the specific needs of disadvantaged and marginalized groups are not taken into account (such as the poor, people facing discrimination; persons with disabilities, victims of natural disasters);
- **Location:** Adequate housing must allow access to employment options, health-care services, schools, child-care centres and other social facilities and should not be built on polluted sites nor in immediate proximity to pollution sources;
- **Cultural adequacy:** Adequate housing should respect and take into account the expression of cultural identity and ways of life.

For more information, see OHCHR, Fact Sheet n°21 Rev.1, “The right to adequate housing”, available at http://www.ohchr.org/Documents/Publications/FS21_rev_1_Housing_en.pdf

- **United Nations Convention on the Rights of Persons with Disabilities**³⁸ (Adopted by the General Assembly of the United Nations on 13th of December 2006, entry into force 3rd of May 2008). The convention encourages the full and effective participation of persons with disabilities in society and development. In its “Article 9”, it demands that States adopt measures to identify and eliminate obstacles and barriers to accessibility, notably in relation to housing. Additionally, Under article 4, which outlines the general obligations of the Convention, States parties commit to “undertake or promote research and development of universally designed goods, services, equipment and facilities, as defined in article 2 of the Convention, which should require the minimum possible adaptation and the least cost to meet the specific needs of persons with disabilities, to promote their availability and use, and to promote universal design in the development of standards and guidelines”.

How to use this handbook to contribute to supporting state

The handbook should be used to support governments and decision makers on acting towards the implementation of their obligations under international law and achieve an inclusive environment, especially in conditions with limited resources as slum upgrading, reconstruction and social housing programmes. Often budgetary constraints or lack of prioritization hamper initiatives to increase accessibility.

³⁸ UN General Assembly, *Convention on the Rights of Persons with Disabilities*, 13 December 2006, available at: <http://www.un.org/disabilities/default.asp?id=262> [accessed 26 January 2014]

Other Standards and Guidelines

- **International Standard ISO 21542:2011 Building construction — Accessibility and usability of the built environment**³⁹ (Published 12 December 2011). The document provides technical recommendations and requirements to define how the built environment should be designed, constructed and managed to enable people to approach, enter, use, egress from and evacuate a building independently, in an equitable and dignified manner and to the greatest extent possible. It does not deal with elements of the external environment, such as public open spaces, neither with single-family dwellings other than those with circulation spaces and fixtures common to two or more dwellings.

How to use this standard in the context of this handbook

The standard provides useful guidance and detailed-specific dimensions to almost all situations and strategies where the adaptation of the physical environment is required. It is important to note that the document makes no reference to cost effective strategies, therefore measures should be adapted to the contexts approached by this publication. It can be used as a reference when designing and dimensioning adequate accessible solutions to each context.

³⁹ *International Organization for Standardization ISO, 2011*

Sustainability: development and building construction conventions/standards/guidelines

- **The future we want**⁴⁰ (Outcome document of the United Nations Conference on Sustainable Development, held in Rio de Janeiro, Brazil in 2012, endorsed by the General Assembly in September 2012). In this document, governments committed to promote sustainable development policies that support inclusive housing and social services; a safe and healthy living environment for all, particularly children, youth, women, older persons and persons with disabilities; affordable and sustainable transport and energy; the promotion, protection and restoration of safe and green urban spaces; safe and clean drinking water and sanitation; healthy air quality; the generation of decent jobs; and improved urban planning and slum upgrading.

How to use this convention in the context of this handbook

This document is a commitment, therefore a tool to impulse governments and decision makers. Increasing accessibility leads to sustainable development through inclusive housing, safe and healthy living environment for all, supporting the implementation the commitments and obligations of states.”

- **International Standard ISO SO 15392 Sustainability in Building Construction—General Principle**⁴¹ (Published in 2008). Presents general principles of sustainability related to buildings and other construction works. The nine general principles form the basis for a suite of standards: continual improvement, equity, global thinking and local action, holistic approach, involvement of interested parties, long term consideration, precaution and risk, responsibility, and transparency. According to the standard, sustainability in buildings and other construction works must include the interpretation and consideration of sustainable development in terms of its three primary aspects – economic, environmental, and social aspects, giving them equal importance.

How to use this standard in the context of this handbook

The principles presented in this specific ISO standard should be considered and applied to enable appropriate decision-making, to meet specific needs in each regional, social and economic context. When balancing technical performance with sustainability, solutions may lead to progressive strategies, addressing specific need and existing conditions.

40 UN General Assembly, *The future we want: resolution / adopted by the General Assembly., 27 July 2012, A/RES/66/288*, available at: <http://sustainabledevelopment.un.org/futurewewant.html> [accessed 25 January 2014].

41 International Organization for Standardization ISO, 2008

- 
- **International Standard ISO/TS 12720:2014 Sustainability in buildings and civil engineering works — Guidance on the application of the general principles in ISO 15392⁴².** (Published in March 2014). The standard provides guidance for the application of the general principles of sustainability in buildings and civil engineering works elaborated in ISO 15392. It shows the different actors involved with the construction works, how to take these principles into account in their decision-making processes, in order to increase the contribution of the construction works to sustainability and sustainable development. In regards to accessibility, the technical standard lists the provision of accessibility for all as one of the sustainability objectives and issues.

How to use this standard in the context of this handbook

The four extensive tables available in this standard should be used to link sustainability objectives and related issues of concern. The standard recommends several possible actions and solutions, e.g. performance requirements during the service life of buildings, identified requirements on functionality, health, comfort, safety and accessibility. The standard can be used to establish rational criteria for indoor air quality, thermal comfort, acoustic comfort, visual comfort, HVAC system controls and accessibility, among others.

⁴² (International Organization for Standardization ISO, 2014)

Development and Reconstruction conventions/standards/guidelines

- **International Standard - The Sphere Handbook: Humanitarian Charter and Minimum Standards in Humanitarian Response⁴³** (First published in 2000, revised in 2003 and in 2009–2010). The latest edition of the Sphere Handbook is the product of a broad inter-agency collaboration. The aim of the Handbook is to improve the quality of humanitarian response in disaster situations and to disaster-affected people.

In this standard, specific references on accessibility and environmentally friendly construction are related to temporary communal settlements or collective centres such as schools and hospitals. References highlight that “people have sufficiently covered living space providing thermal comfort, fresh air and protection from the climate ensuring their privacy, safety and health and enabling essential household and livelihood activities to be undertaken.”

How to use this standard in the context of this handbook

The document highlights that persons with disabilities face disproportionate risks in disaster situations and are often excluded from relief and rehabilitation processes. Sphere standards give construction guidelines to reflect principles of accessibility. The document has an assessment checklist, which includes the evaluation of design features required to ensure safety, accessibility and use of shelter solutions by all members of the affected population, in particular those with mobility difficulties.

⁴³ (The Sphere Project, 2011)

- 
- **International standard - The Pinheiro Principles: United Nations Principles on Housing and Property Restitution for Refugees and Displaced Persons**⁴⁴ (endorsed on 11 August 2005). The Pinheiro Principles were developed to provide practical guidance on how to best address the legal and technical issues surrounding housing, land and property restitution in displacement situations. Among its 23 principles, the document states that everyone has the right to adequate housing, and States should adopt positive measures aimed at alleviating the situation of refugees and displaced persons living in inadequate housing.

How to use this standard in the context of this handbook

When addressing reconstruction or restitution, it is key to access *The Pinheiro Principles*. The document gives substantial recommendation and basis to the inclusion of older persons and persons with disabilities in decision-making processes. It stresses that the needs of this vulnerable group should be given particular attention.

- **Basic Principles and Guidelines on Development - Based Evictions and Displacement**⁴⁵ (published on 5 February 2007). The guidelines were elaborated to assist States and the international community in developing policies and legislation to address forced evictions. Forced evictions affect significantly those living in extreme poverty, including older persons and persons with disabilities. The guidelines focus on measures and procedures to be adopted in order to ensure

that development-based evictions respect existing international human rights standards, including the right to adequate housing.

How to use these guidelines in the context of this handbook

The guidelines are a practical tool to assist States and agencies in developing policies, legislation, procedures and preventive measures to avoid forced evictions. The guidelines also provide solutions for persons threatened with or subject to forced evictions, when prevention fails.

- **Guiding Principles on Security of Tenure for the Urban Poor**⁴⁶ (published on 30 December 2013).

The Principles were elaborated responding to the global tenure insecurity crisis, which represents a pressing challenge for the implementation of the rights to adequate housing. The guiding principles are ten, as follows: strengthening diverse tenure forms, improving security of tenure, prioritizing in situ solutions, promoting the social function of property, combating discrimination on the basis of tenure, promoting women's security of tenure, respecting security of tenure in business activities, strengthening security of tenure in development cooperation, empowering the urban poor and holding the State accountable and finally ensuring access to justice.

⁴⁴ (Centre on Housing Rights and Evictions (COHRE), 2007)

⁴⁵ (UN General Assembly, 2006)

⁴⁶ (UN General Assembly, 2013)



How to use these guidelines in the context of this handbook

The Principles should be used to provide guidance to States and other actors to address security of tenure for the urban poor and vulnerable people, including older persons and persons with disabilities.

BOX 5: LOCAL APPROACH TO ACCESSIBILITY IN SOCIAL HOUSING PROGRAMMES: THE CASE OF SÃO PAULO, BRAZIL.

The state of São Paulo is the most populous in Brazil (over 40 million inhabitants) and the third most populous political unit of South America. The city of Sao Paulo is actually the largest city in Brazil and in the Southern Hemisphere, and the world's seventh largest city by population (over 19 million inhabitants in its metropolitan region).

The State of São Paulo was the pioneer in the country to adopt the concepts of Universal Design for Social Housing. Since 2008, state Department of Housing (SH) and the state Secretariat of the Rights of Persons with Disabilities (SDPcD) work together to apply these concepts in low-income housing programs. Under an agreement between SH, SDPcD and the Company of Housing and Urban Development (CDHU), a working group composed of experts has developed a manual for Universal Design in Social Housing⁴⁷. The publication presents the principles that should guide the development of projects and the construction of affordable housing.

Under the motto "Space for everyone and for a lifetime", the adoption of universal design, as state public policy aims to ensure that the living space in its urban context offers security, self-esteem, citizenship, longevity and flexibility. The expected outcome is that housing, public spaces and local urban surroundings will be enjoyed throughout the life of an individual in a democratic manner.

47 (SH, SDPcD, CDHU, 2010)



CHAPTER

04

Technical guidelines to support accessible affordable housing

The technical guidelines presented in this chapter are based on existing universal design, accessibility standards and good practice.⁴⁸ They are complementary to the checklists presented at the Annex 1 and should be applied together with the checklists. The technical guidelines should be used with discernment according to local needs and conditions. Beyond design recommendations, boxes 5 and 6 present advice on the use of local building materials and site selection aiming to increased sustainability and accessibility. Anthropometrics are displayed in the box 7: these useful measurements serve as guidance when designing and adapting facilities for persons with disabilities.

⁴⁸ (Wolfgang F. E. Preiser, 2010) (Inter-American Development Bank, 2007) (United Nations, Department of Economic and Social Affairs (UNDESA) Division for Social Policy and Development, 2004) (Jack Nasar, 2007) (International Organization for Standardization ISO, 2011)

BOX 6: USING SUSTAINABLE LOCAL BUILDING MATERIALS TO CREATE ACCESSIBILITY⁴⁹

Local building materials may offer feasible solutions to address lack of resources: limited budget, difficulty in accessing construction sites or industrialized material, or in introducing new technologies to local people (workers and community in general) especially in the contexts of slum upgrading and reconstruction. The adequate use of local resources is an excellent strategy to increase sustainability, as it reduces costs and pollution caused by transportation. Moreover if appropriately used as several examples in the past (e.g. vernacular architecture), some local materials have very good thermal performance, therefore reducing the needs of expensive high-tech solutions to increase indoors comfort. The wise combination of traditional and new technologies has a strong potential to increase energy efficiency in buildings. Low embodied energy materials are also important for the environmental sustainability of housing.

It is important to note that solutions aimed at increasing accessibility in buildings such as railings, handrails and grab bars, are structures that must be fixed on walls and ceilings. Even if most of the building is made with a light structure, the walls and ceilings in which supporting fixtures as previously mentioned are installed must be reinforced. They must guarantee safety of all occupants' without disregarding durability. This will ensure the structural integrity, energy efficiency and longevity of the project.

When building up disaster resistance of flood prone areas, consideration should be given to durability, resilience and resistance of indigenous materials. Durable and water resistant materials allow structures to withstand extreme flood events, and maintain the structural integrity of the building. This is crucial when designing curb ramps and accessible routes.

FIGURE 1: HOME FOR OLDER PERSONS IN CHAIMAI PROVINCE, THAILAND



©Teera Kaaengthonglang/NHA Thailand

Some specific guidance related to the use of local materials and sustainable construction principles:

- Give preference to building materials with a **minimum of complex integrated parts**, in their natural state or minimally processed (stone, raw timber, earth, straw). They require less energy inputs.

⁴⁹ (UN-Habitat, 2011)

- Choose **locally available** building **materials**, it avoids long distance transportation from the site of extraction/manufacturing to the construction site.
- **Avoid the use of building materials that have a significant environmental impact** during its extraction or manufacturing (heavy mining, destructive logging, high energy processing, or massive water use).
- Attempt to **reduce the use of Portland cement** substituting concrete, mortar and cement based plasters for clay, earthen based or biomass-based materials (wood, bamboo, adobe or compressed earth block, or utilize substitute pozzolanas), without reducing the structural integrity of the construction.
- Whenever possible, prefer **re-used, recycled (or with recycled content) and recyclable** materials.
- Given that they are locally found and sustainably harvested, use renewable materials: wood, straw, bamboo and bagasse. They are biomass based building products which are not as scarce as conventional building materials.

It is crucial that the selection of materials is a result of an assessment and confrontation of availability, environmental impact, local needs and context.

BOX 7: SITE LOCATION

When developing new social/affordable housing programmes, many aspects may affect the criteria for the most appropriate site selection: environmental conditions, safety, economics and political or cultural issues. As a result, these programmes can be located in areas often disconnected from the city and its facilities or in challenging topographic zones, which complicates finding solutions to accessibility.

In parallel, mass housing programme developers tend to reduce design and construction costs through the careless reproduction of the same model of housing in different contexts and locations. A compromise should be found, as the type of the building must be able to be adapted to local environmental conditions and the topography, among other aspects that directly impact on local accessibility. This reduces project costs, specifically those related to soil movement, and maintenance.⁵⁰ For instance, when a steep sloped terrain is the best possible option for a low-cost housing scheme, a proper drainage system should be put in place, together with accessible routes to provide the whole community with decent urban integration.

⁵⁰ (Inter-American Development Bank, 2012)

BOX 8: ANTHROPOMETRICS OF WHEELCHAIR AND CANE USERS

The dimensions displayed below can be used as basis when designing for people in wheelchair and using canes or similar auxiliary devices. Nevertheless, it is important to note that individual measures vary with time (from childhood to old age), from one person to another and also from one region of the globe to another.

FIGURE 2: ANTHROPOMETRICS

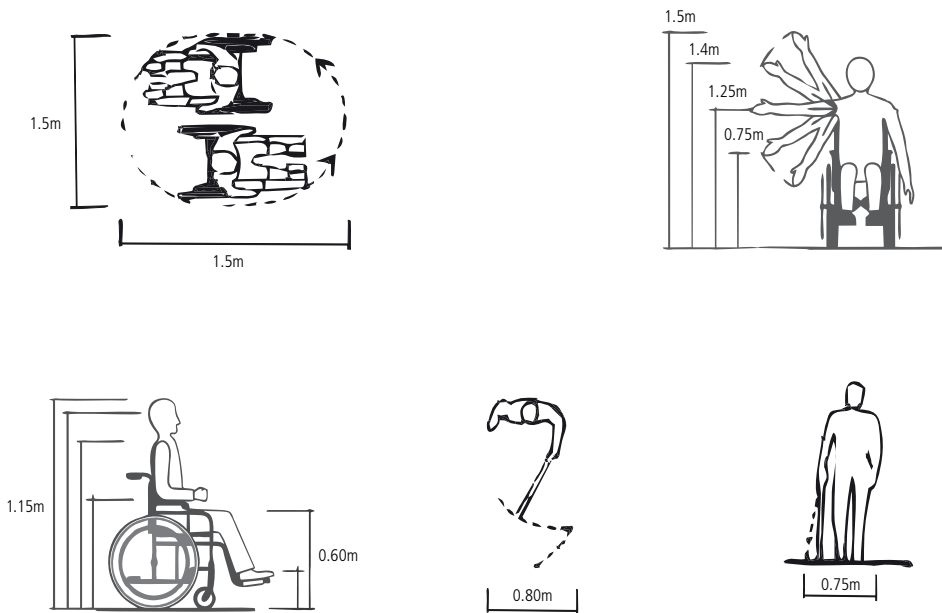

© UN-Habitat 2014, Adapted from (United Nations, Department of Economic and Social Affairs (UNDESA) Division for Social Policy and Development, 2004)

Design recommendations: urban environment and public spaces

In slum upgrading or social housing programmes, existing public spaces should be improved in order to be inclusive and accessible. When inexistent, these areas should be part of the upgrading plan,

developed with equal focus on accessibility and universal design. The recommendations below can be applied and adapted to both existing or intended public spaces and areas to be urbanized.

FIGURE 3: STREET FURNITURE VIEW

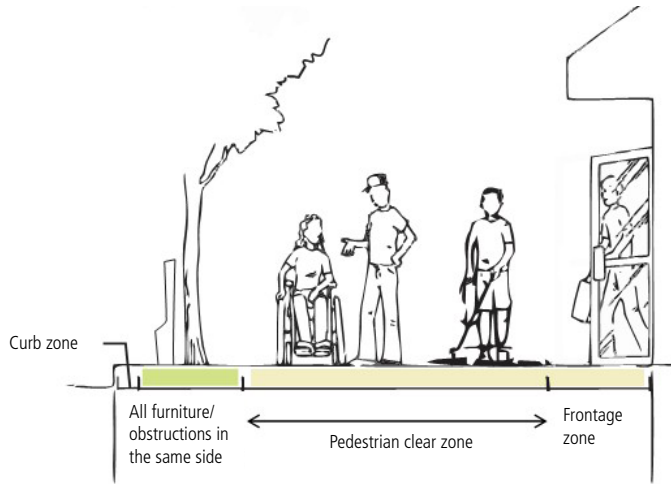

© UN-Habitat 2014, Adapted from (Inter-American Development Bank , 2007) and (United Nations, Department of Economic and Social Affairs (UNDESA) Division for Social Policy and Development, 2004)

Street Furniture and accessible urban design

Street furniture means objects and equipment installed on streets and roads for different purposes such as benches, bus stops, fountains, garbage bins, kiosks, mailboxes, phone boxes, plants, streetlamps, traffic barriers, traffic lights and traffic signs. These objects and equipment can become an obstruction instead of a supportive urban element when not properly located and designed: they should be placed outside the path of travel, in a continuous line, located in a way that it will not hinder the passage of pedestrians. Additionally, street furniture should be clearly indicated and easy

to be identified by a vision-impaired person (VIP). Textural changes in the footpath surface help vision impaired persons to identify the location of public amenities⁵¹.

The appropriate placement of objects or equipment has a significant impact on mobility in any context, urbanized or not. In order not to jeopardize upgrading programmes, it is key to coordinate design and implementation with service providers such as telecommunications, lighting and landscaping companies, among others.

⁵¹ (United Nations, Department of Economic and Social Affairs (UNDESA) Division for Social Policy and Development, 2004) and (Inter-American Development Bank , 2007)

FIGURE 4: STREET FURNITURE PLAN

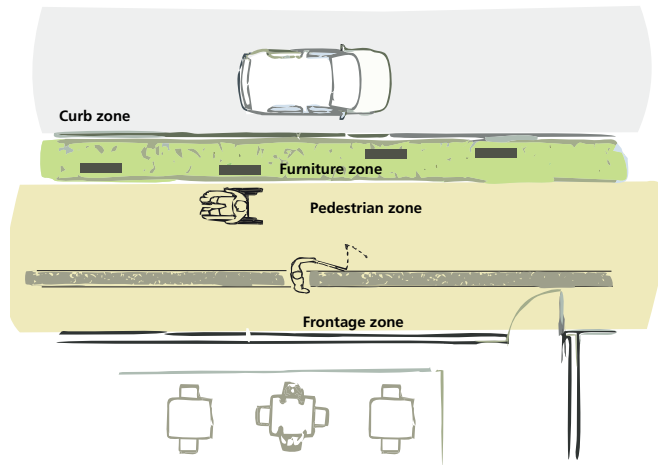

© UN-Habitat 2014 Adapted from SEDHAB

Sidewalks can be characterized by a curb zone, which provides a barrier between the street and sidewalk, furniture zone, where all items that could block pedestrian traffic should be placed, the pedestrian clear zone and a frontage zone to ensure space between pedestrians and buildings. The pedestrian clear zone should be at least 0.90m for one-way wheelchair linear displacement and 1.20m two-ways⁵².

Signage

Signage for accessible environments may vary considerably. It includes direction signs, signs of locality, street names and numbering, information signs, etc. They should be visible, clear, simple, easy to read and understand, and properly lit at night.

⁵² (United Nations, Department of Economic and Social Affairs (UNDESA) Division for Social Policy and Development, 2004)

FIGURE 5: TRAFFIC LIGHTS WITH AUDIBLE AND VISUAL SIGNAL

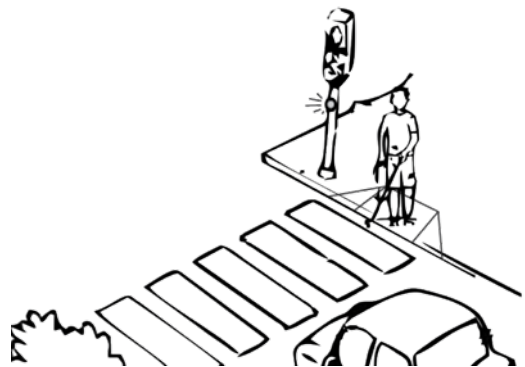

© UN-Habitat 2014 Adapted from SEDHAB

Tactile paving (textural changes in the sidewalk's surface) helps visually impaired pedestrians to identify the location of street furniture, access to buildings, equipment and public transportation.

FIGURE 6: TACTILE WARNING AND DIRECTIONAL FLOOR

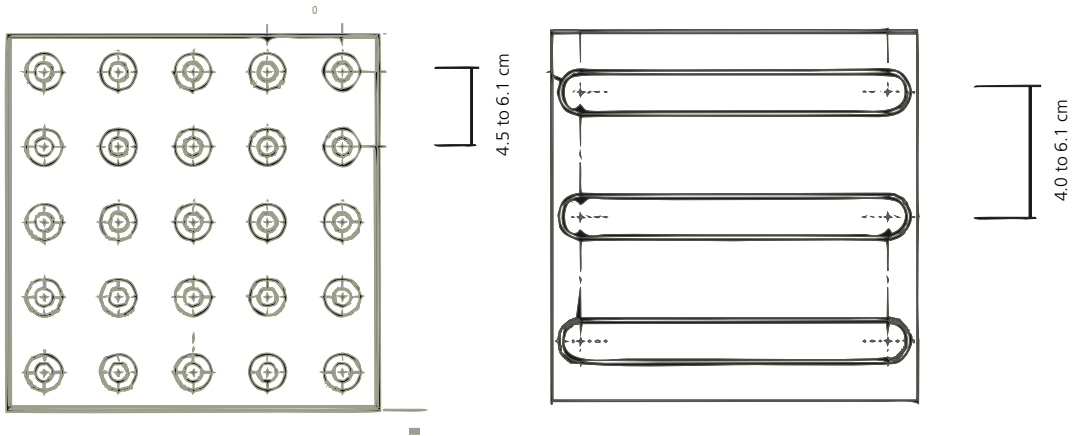

© UN-Habitat 2014

The *tactile warning floor* can be felt underneath the shoes. It is especially useful in areas with street crossings, sloping paths or shared surfaces which might put VIPs in danger. The *tactile directional floor* guides the cane of a sightless person between its embossed strips throughout the pathway.

When used in sidewalks, they should be made of a resistant and non-slippery material and should have a different, contrasting colour from the sidewalk. When warning and directional signs are combined, it is key that persons with visual impairment are able to clearly identify both of them⁵³.

Curb Ramps and Pedestrian Crossings

Curb ramps are crucial elements of a universally accessible environment. They should be used wherever there is a difference in level on pedestrian paths or cross paths, keeping the same width of pedestrian paths (minimum 0.90m, recommended 1.20m)⁵⁴.

⁵³ (International Organization for Standardization ISO, 2011)

⁵⁴ (United Nations, Department of Economic and Social Affairs (UNDESA) Division for Social Policy and Development, 2004)

FIGURE 7: APPLICATIONS OF TACTILE FLOOR.

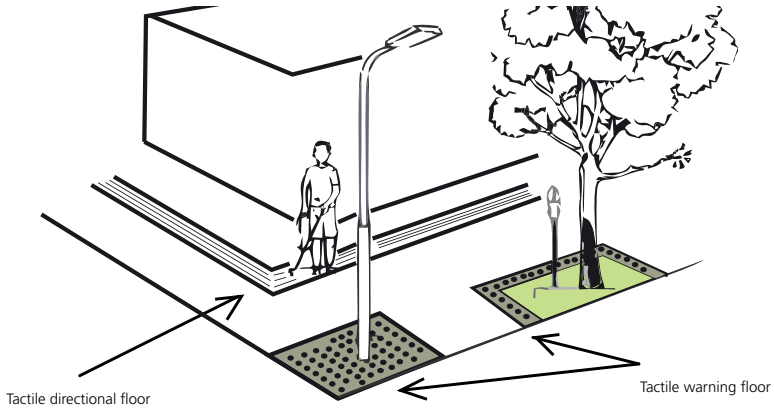

© UN-Habitat 2014

FIGURE 8: EXAMPLES OF CURB RAMPS

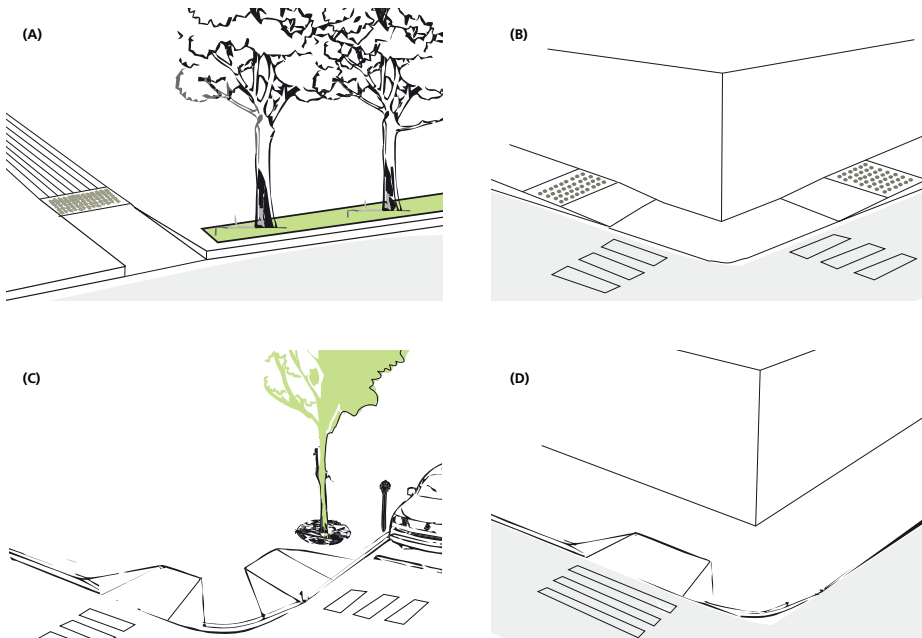

© UN-Habitat 2014, Adapted from (United Nations, Department of Economic and Social Affairs (UNDESA) Division for Social Policy and Development, 2004)

FIGURE 9: CURB RAMP WITH WARNING AND DIRECTIONAL TACTILE SIGNAGE IN, BRASILIA, BRAZIL



© Renata Gomes.

Pedestrian crossings should ideally be equipped with traffic control signals. When persons with disabilities frequently use specific low-traffic crossings, a pedestrian push-button system should be installed. Guide strips (tactile directional floor) should be used to indicate the position of the pedestrian crossing. They should lead to a curb ramp with a pedestrian light pole.

There are different types of accessible pedestrian crossings, depending on the flux of pedestrians, width of the sidewalk and width of the road. The curb ramp might have the same width as the pedestrian crossing strips (see fig 8, example D). Another option is to lower the entire corner of a street (see fig 8, example B). When an area has high pedestrian flow an alternative is the elevated pedestrian crossing, as shown in figure 10.

FIGURE 10: ELEVATED PEDESTRIAN CROSSING, BRASILIA, BRAZIL



© Renata Gomes

FIGURE 11: PARKING SPACES

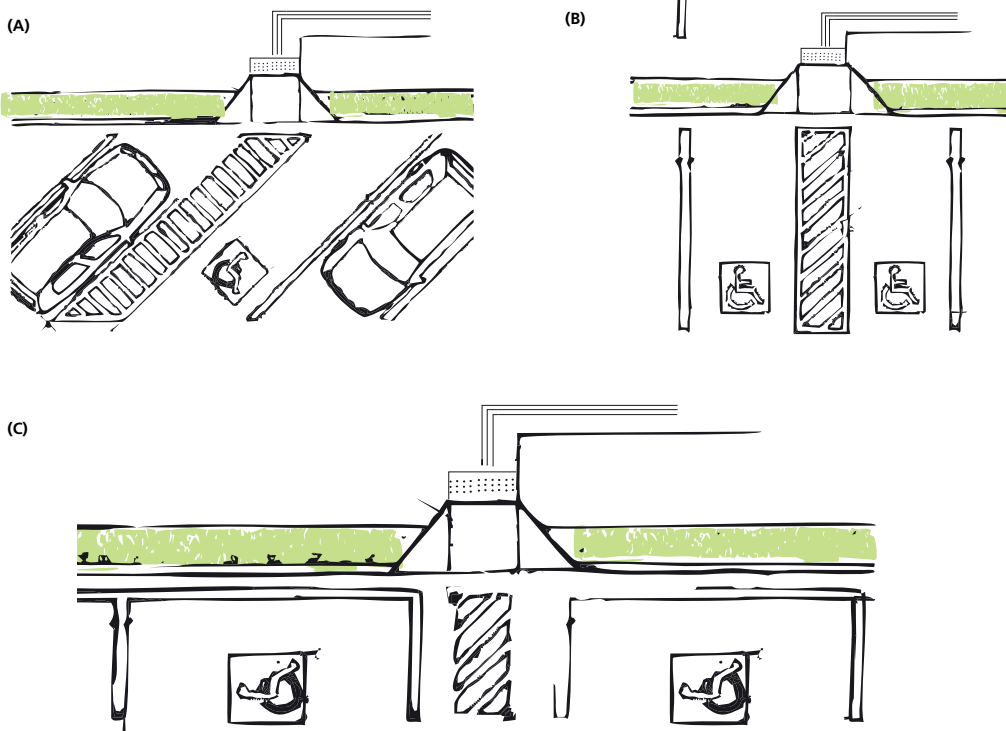

©UN-Habitat 2014, Adapted from: (ABNT, 2004)

Parking

Designated parking spaces should be located as near as possible to the building's main entrance. Minimum requirements for parking spaces should follow national regulations. If not available, The "International Standard ISO 21542:2011" can be used as a reference.

Car parking areas with accessible parking spaces must have an additional circulation zone with minimum of 1.20m width and marked with

visual signage⁵⁵. This space can be shared by two openings as shown in Figure 11 types B and C. It is not recommended to share in oblique parking (Figure 11 type A). It should be associated with curb ramps, and if it is not, the parking area must contain space for wheelchair travel.

⁵⁵ (United Nations, Department of Economic and Social Affairs (UNDESA) Division for Social Policy and Development, 2004)

Routes

When developing affordable, social housing, reconstruction or slum upgrading programmes, it is crucial to provide at least one accessible and safe route, linking main public facilities as bus stops, to public spaces and buildings.

FIGURE 12: KEY ELEMENTS OF AN ACCESSIBLE ROUTE

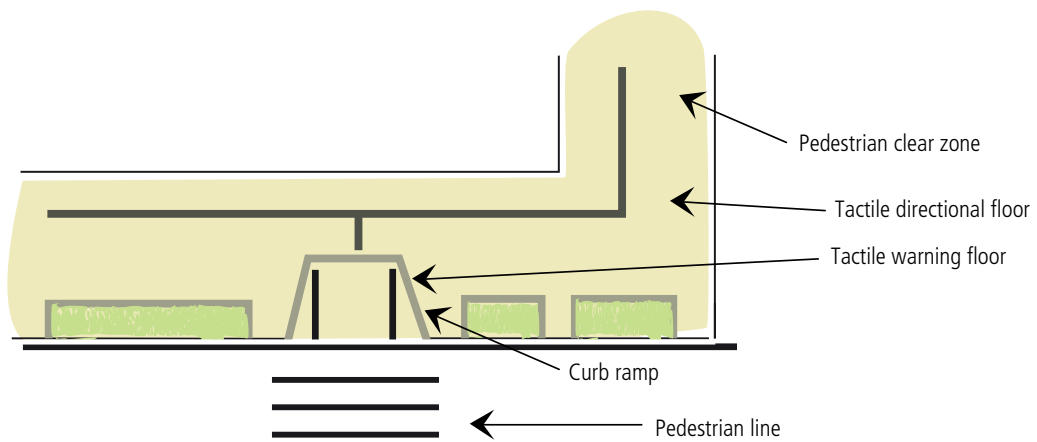

© UN-Habitat 2014

Design recommendations: Housing Units

A house designed today may be the home for a family for their entire life. It should be flexible enough to accommodate the changing needs (from childhood to old age, accidents or illnesses that may lead to disability) that will occur during the different cycles of life. If the changing needs are considered from the first stage of design, there are no additional costs to adaptation. The following are some strategies to guide the designers and planners in this task.

Entrances

Ideally, the approach to all entrances should be level or gently sloping.

In flood prone zones and other areas requiring elevated houses, a ramped access is a feasible solution to help mobility-impaired people to enter their houses. In multi-storey buildings, the accessible entrance should lead to an accessible elevator or lift.

FIGURE 13: ACCESSIBLE ROUTE

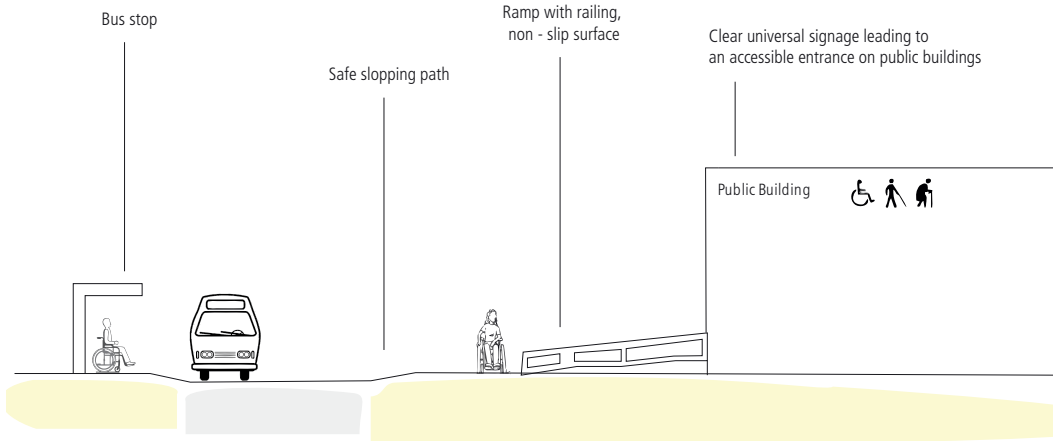

© UN-Habitat 2014, Adapted from: (Inter-American Development Bank, 2007)

FIGURE 14: RAMPED ACCESS OPTIONS IN ELEVATED HOUSE

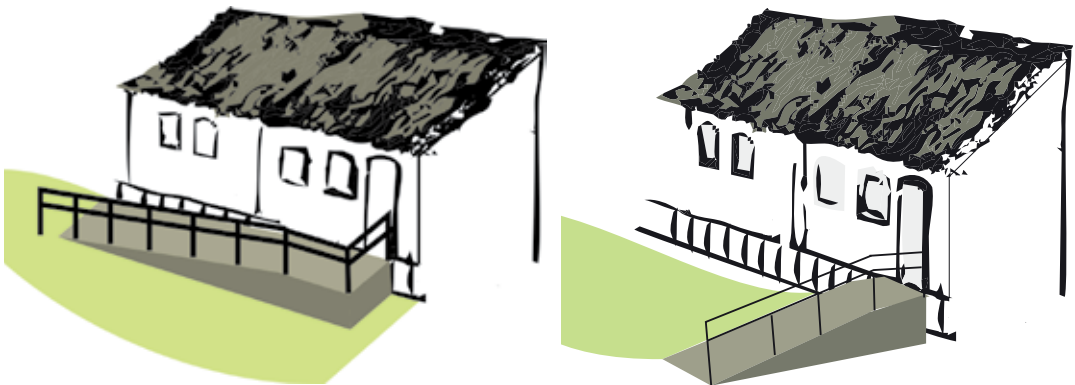

© UN-Habitat 2014

Ramps/Elevators/Lifts

Often high-density social housing projects are built as multi-story buildings. In these cases, buildings' distribution along the terrain might be adequate to the slope or other urban planning strategies, in order to avoid major earthworks, problems with drainage and jeopardizing accessibility. An accessible route should be provided to all entrances (see sub-chapter 4.3 Accessible Routes), and ramps should be placed linking the main entrance of the buildings to these routes.

Usually these ramps are made of concrete and cement due to their high resistance to loads applied by wheelchairs and strollers, but low cost solutions using local materials as bamboo or wood may be a good option. It is important to build a safe and weight-resistant ramp, with a regular and stable surface. For instance, wooden planks and boards on a slatted structure can be used, provided it is resistant towards variable weather conditions (rain, sun, wind, etc.) and is properly installed, levelled to avoid obstacles as bumps that may cause accidents.

FIGURE 15: RAMPED ACCESS

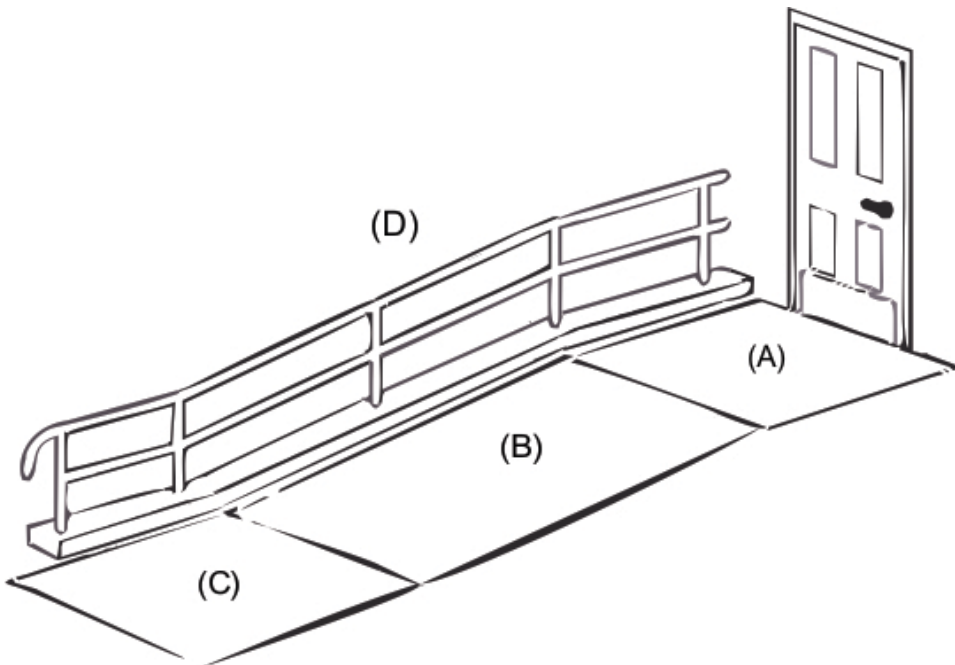

© UN-Habitat 2014, Adapted from (United Nations, Department of Economic and Social Affairs (UNDESA) Division for Social Policy and Development, 2004)



The slope of a ramp, according to the International Standard ISO-FDIS-21542, may vary from 12,5 per cent to 5 per cent for heights between 75mm (0.075m) and 500mm (0.50m), respectively. This means that the greater the height to overcome, the lower the ramp tilt should be. The standard recommends the use of handrails for ramps from 210mm (0.21m) height. The Standard also gives exceptional slope dimensions to adapt building entrances and urban areas.

The width of a ramp should be 1.20m, with an unobstructed width of 1.0m (Figure 15 (B and C)). A landing area, both at foot and head of the path (Figure 15 (A and C)) should be provided. A handrail (Figure 15 (D)), height between 0.85m and 1.0m above the surface of the ramp⁵⁶, is recommended for ramps from 210mm (0.21m) height.

As a general rule, the greater the height to overcome, the lower should be the ramp tilt. In case of restricted resources minor variations of gradient can be applied. It is important to highlight that the more sloped a ramp is, the harder it is for the mobility-impaired person to access/leave the house without assistance, increasing risks of accidents. A compromise between assisted accessibility and independency is required.

For constant two-way traffic, ramps a clear path width should be at least 1.80m (Figure 16 (A1)). For frequent two-way traffic, ramps should provide 0.25m space for passing and turning (Figure 16 (B1))⁵⁷.

In case of restricted resources minor variations of gradient can be applied. The ISO-FDIS-21542 standard also gives exceptional slope dimensions to adapt building entrances and urban areas.

56 (International Organization for Standardization ISO, 2011)

57 (International Organization for Standardization ISO, 2011)

FIGURE 16: RAMPS FOR CONSTANT (A1) AND FREQUENT (B1) TWO-WAY TRAFFIC

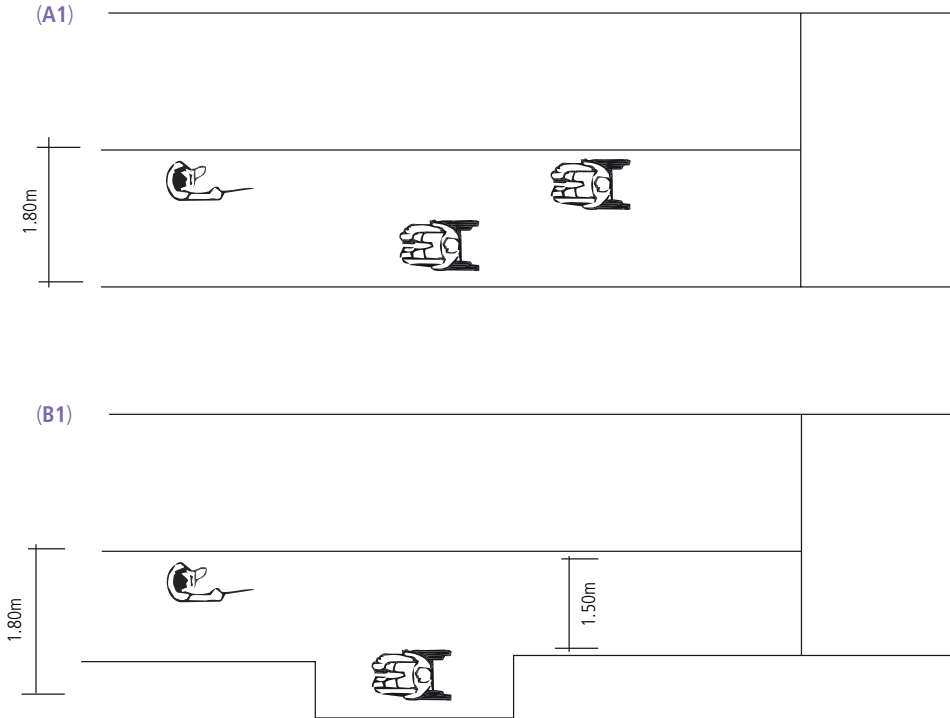

© UN-Habitat 2014, Adapted from (International Organization for Standardization ISO, 2011)

Elevators ideally should be installed in social housing projects with multi-story buildings to guarantee equal and full accessibility of the housing units. It is also recommended to install elevators close to a building's main entrance and stairs whenever there is a difference of level higher than 2.5 m.

The minimum internal dimensions of an elevator cab should be 1.10 m x 1.40 m and clear door opening of 0.90 m⁵⁸.

⁵⁸ (International Organization for Standardization ISO, 2011)

FIGURE 17: ELEVATORS

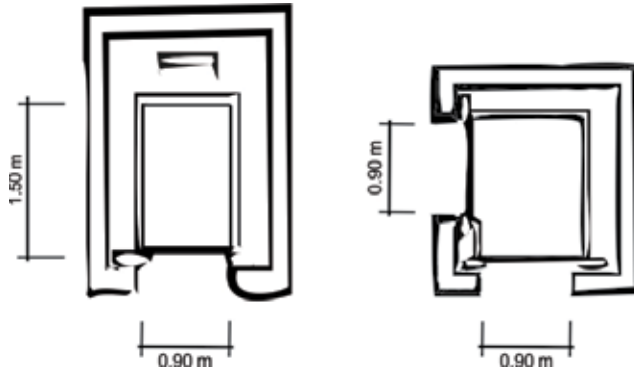

© UN-Habitat 2014, Adapted from (International Organization for Standardization ISO, 2011)

In cases where budgetary or technological issues hinder the installation of elevators at the construction phase, enough space and adequate structure should be provided allowing its future installation. In these cases, adapted housing units at the ground floor should be preferably given to persons with disabilities and their families.

Lifting platforms can be used to overcome vertical barriers up to 2.50m. For difference of level of less than 1.20m, lifts may have only one door in the accessible level. For safety reasons, in cases where the difference is more than 1.20m, it should be placed in a closed structure with doors at the different accessible levels⁵⁹.

FIGURE 18: LIFTING PLATFORM



© UN-Habitat 2014

⁵⁹ (United Nations, Department of Economic and Social Affairs (UNDESA) Division for Social Policy and Development, 2004)

Railings And Handrails

Railings should be installed around unsafe areas, stairs, ramps, accessible roofs, mezzanines, galleries, balconies and raised platforms more than 0.40m high.

Handrails should have at least two heights: 0.60m to 0.75m to benefit wheelchair users and the ordinary height of 0.85 to 1.00m. They should extend horizontally for a distance between 0.30m and 0.45m at the top and bottom of stairs and ramps, except in places where extensions could obstruct the pedestrian flow⁶⁰. Handrails can be also installed along steep routes, provided well fixed, e.g. on external housing walls, to assist older

persons and mobility impaired people to move safely.

Handrails can be made of any material that supports a certain load, as people may lean on it. Materials should also be weather resistant and well polished, free of sharp edges and rough surfaces.

Make use of easy to grip handrails, preferably rounded with a diameter of 3.50 - 4.50cm. They should be installed with a minimum distance of 0.40m to the adjacent wall to allow enough space for the hand to grab it⁶¹. The handrail should be wide enough to be grabbed by an adult but not too wide, to be grabbed by a child.

FIGURE 19: RAILINGS AND HANDRAILS

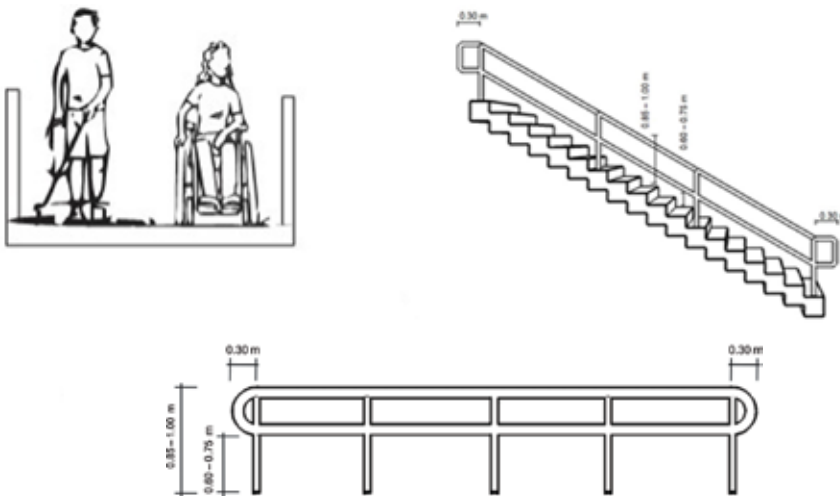

© UN-Habitat 2014, Adapted from (United Nations, Department of Economic and Social Affairs (UNDESA) Division for Social Policy and Development, 2004)

60 (International Organization for Standardization ISO, 2011)

61 (International Organization for Standardization ISO, 2011)

FIGURE 20: PREFERRED HANDRAILS



© UN-Habitat 2014, Adapted from (United Nations, Department of Economic and Social Affairs (UNDESA) Division for Social Policy and Development, 2004)

Doors

To guarantee the passage of a wheelchair and other equipment, the minimum clear opening of doors should be 0.85m, including sliding doors.

The door handle should be easy to grip and operate, preferably lever style.

FIGURE 21: DOOR HANDLE

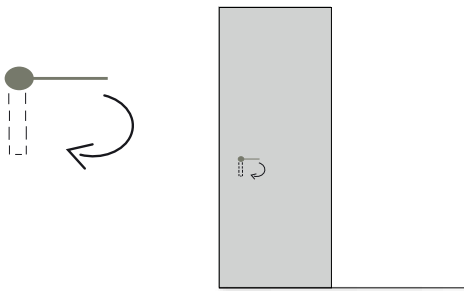

© UN-Habitat 2014

Corridors

The minimum width of a corridor will depend on its configuration. It should allow enough space for a wheelchair to turn.

FIGURE 22: TURNING SPACE IN CORRIDORS

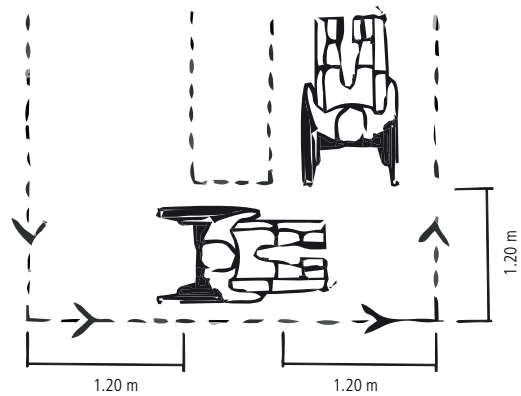

© UN-Habitat 2014, Adapted from International Organization for Standardization ISO, 2011

Living areas

Ideally, a living space should be provided on the entrance level of every dwelling.

Every accessible area should have a clear manoeuvring space of 1.5m diameter.

Working surfaces and also key task areas and kitchen sinks can be adapted to a wheelchair. They should be mounted at approx. 0.75m height and have a knee recess of at least 0.80m depth to allow wheelchair access.

FIGURE 23: BEDROOM WITH BATHROOM

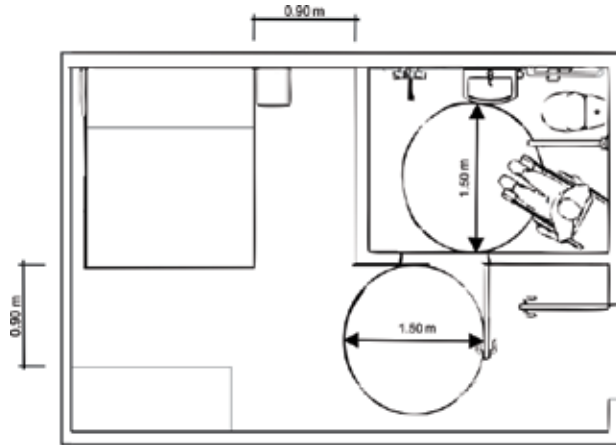

© UN-Habitat 2014, Adapted from (International Organization for Standardization ISO, 2011)

FIGURE 24: WORKING SURFACES, E.G. KITCHEN SINK



© UN-Habitat 2014

Windows should provide outdoor view and be operable from a wheelchair. They should be fitted with handles that are easy to grip and operate (lever style), and be within easy reach for a small person or wheelchair user.

FIGURE 25: OPERABLE WINDOWS

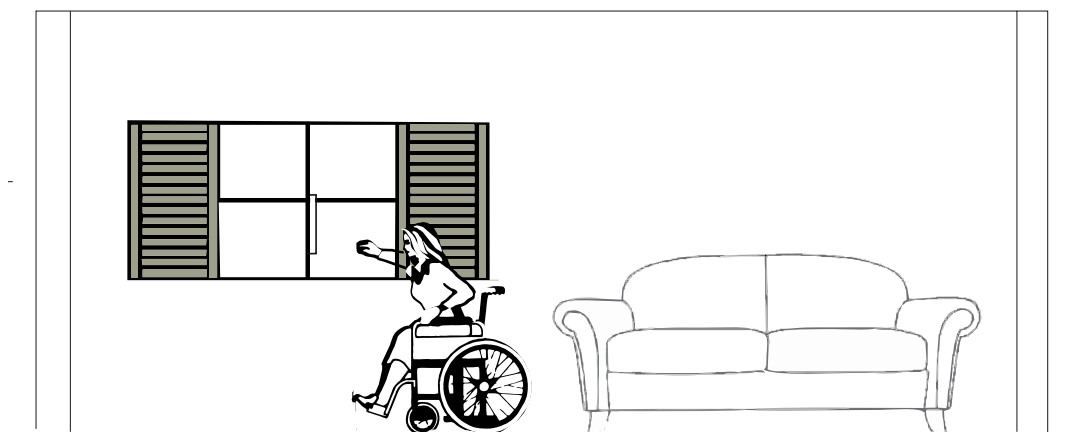

© UN-Habitat 2014

Rest Rooms

Walls in all bathrooms and toilet compartments should be capable of firm fixing and support for adaptations such as grab rails.

Rest rooms ideally should have clear circular space of 1.50 m diameter for wheelchair manoeuvring and transferring to toilet seat (minimum 1.20m). When not possible, they should be equipped with grab bars, mounted at a height between 0.85m and 0.95m from the floor. Whenever existent, flushing arrangements and toilet paper should be placed within reach at a height between 0.50m and 1.20m.

Low mirrors or downward tilted mirrors are suitable for both standing and seated persons.

Public toilets in slums should provide at least one accessible facility, with grab bars and space for manoeuvring whenever possible. If elevated from the ground floor, ramps should be provided (see sub-chapters 4.2.1 and 4.2.2). Enough natural lighting and ventilation should be provided, for health reasons but also to attend to the needs of vision impaired people.

FIGURE 26: RESTROOMS WITH CLEAR CIRCUMSCRIBED MANOEUVRING AREA

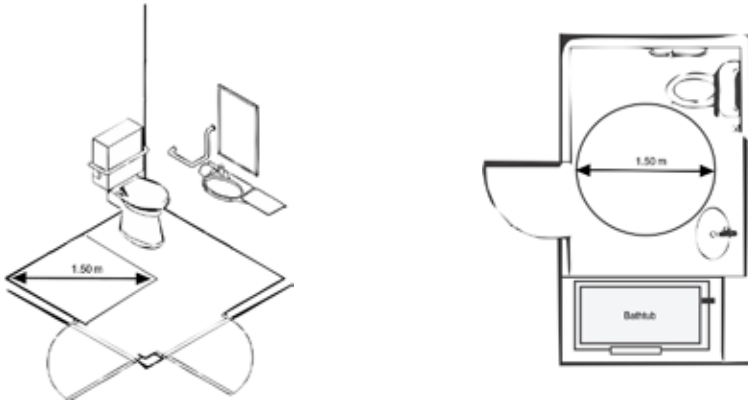

© UN-Habitat 2014, Adapted from (International Organization for Standardization ISO, 2011)

Alternatively, in situations of very limited resources or unavailability of flushing arrangements, a supporting seat can be made of wood, cement or other adequate material, provided there is sufficient thickness to handle the weight of an

adult person. Additionally, a collection bin should be placed under the seat for cleaning purposes (Figure 29). Wooden grab bars properly fixed on walls or any existent structure can be a feasible, low cost alternative (Figure 30).

FIGURE 27: WOODEN SEAT WITH COLLECTION BIN AND GRAB BARS



© UN-Habitat 2014, Adapted from Thailand National Housing Authority

FIGURE 28: ALTERNATIVE WOODEN GRAB BARS

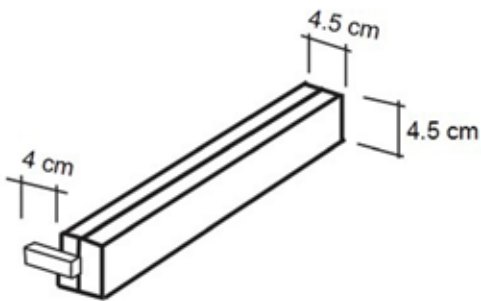

© UN-Habitat 2014

In situations where flat toilets are most culturally accepted, it is possible to have it installed in an elevated wooden floor (fig. 31) to facilitate cleaning and drainage. In these cases, supporting grab bars should be installed in a lower height than usual. Depending on the conditions and degree of deficiency, the users should be consulted to examine the need for double height grab bars.

Accessible routes

Accessible routes, connected to existing regular routes, are crucial to urban integration. They facilitate the life not only of mobility-impaired people but also enable delivery and loading of goods allowing income generation, vehicle access in case of emergency and infra-structure services,

FIGURE 29: DRY FLAT TOILETS ON ELEVATED WOODEN FLOOR



© UN-Habitat 2014, Adapted from Thailand National Housing Authority

increased security. Accessible routes should connect entrances to indoor or outdoors parking areas, local public transportation, drop-off areas and public buildings and spaces, as further detailed in 4.3.1.

Crossings should allow good traffic flow between pedestrians, cyclists, and car routes avoiding conflicts that compromise the security of all citizens.

In slums where compacted soil is the most common material of streets and paths, it is key to guarantee it is at least well compacted, levelled and free of boulders or debris that may cause accidents such as stumbling or the turning over of wheelchairs and strollers.

FIGURE 30: ACCESSIBLE ROUTES AND PEDESTRIAN CROSSINGS

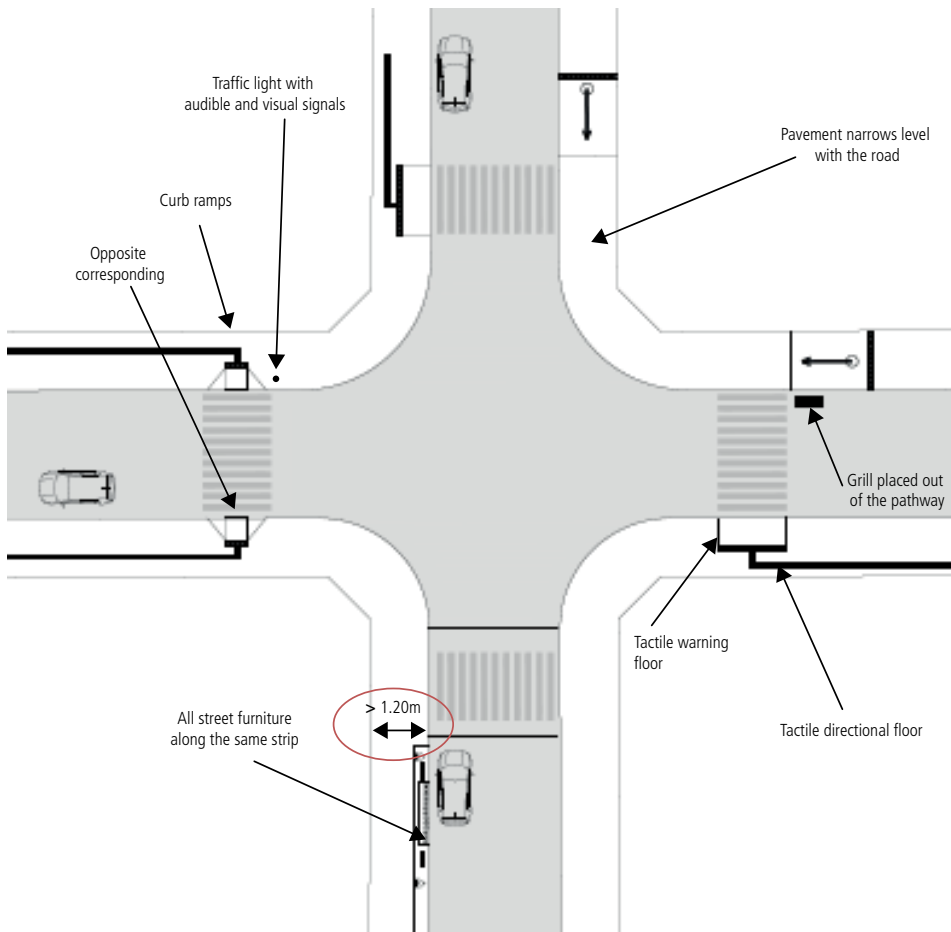

© UN-Habitat 2014, Adapted from (Inter-American Development Bank , 2007)

In **flood prone zones**, a simple alternative is to build elevated, flood resistant pathways connecting specific buildings in the community. Pathways should follow same technical recommendation as

entrances and ramps (see 4.2.1, 4.2.2 and 4.2.3), be at least 1.20m wide and equipped with handrails.

FIGURE 31: ELEVATED PATHWAYS

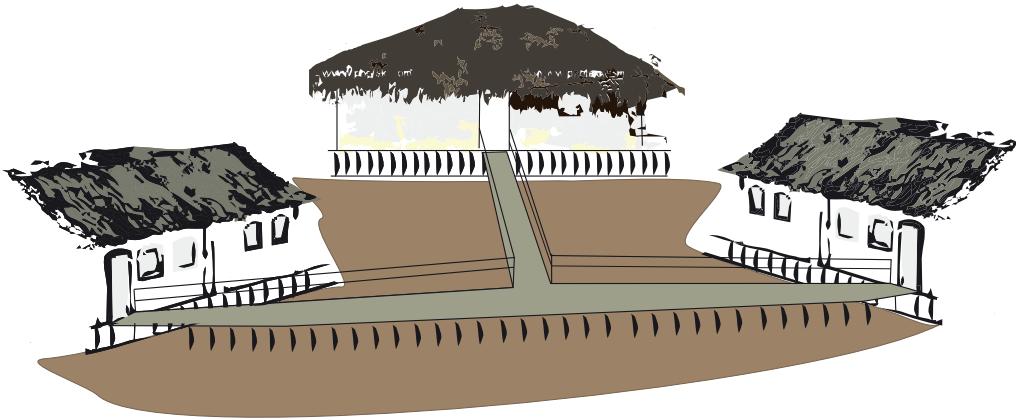

© UN-Habitat 2014

Criteria of eligibility

Accessibility of a route, a location, an object or an environment involves people arriving, entering, using and leaving in safety and with the greatest degree of equity, autonomy and comfort possible.

Simple steps can help to define which should be the accessible routes in a community including new developments or existing ones⁶²:

1. Outline the main points of connection and integration with local transport;
2. Identify pedestrian flows: indicate main points of origin and destination (markets, services, institutional buildings, bus stops, crosswalks, etc.);
3. Link pedestrian flows to the connection points and to the different modes of public transportation;
4. In case of slum upgrading or existing infrastructure, after the identification of pedestrian flows and definition of accessible routes, an assessment of the local conditions and adequacy to accessibility should be carried out.

62 (Vasconcellos, 2011)

BOX 9 : PRACTICAL EXAMPLE VILA DOS CEGOS (VILLAGE FOR BLIND PEOPLE), BRASILIA, BRAZIL.

The “Vila dos Cegos” project was built in 2009 in “Riacho Fundo”, a suburban town 25 km outside Brasília, the capital of Brazil. It was designed by the Housing, Land Regularization and Urban Development Department, SEDHAB (“Secretaria de Estado de Habitação, Regularização e Desenvolvimento Urbano”) in compliance with the Brazilian Standard NBR9050. The project was supposed to address 50 lots, residence of visual-impaired people, but was only partially implemented: only the public spaces, public buildings and routes are, in fact, accessible.

FIGURE 32: PEDESTRIAN FLOWS AND ACCESSIBLE ROUTES



©SEDHAB, Adapted from SEDHAB

FIGURE 33: (A) BUS STOP AND PATHWAY SIGNALIZED WITH TACTILE DIRECTIONAL FLOOR: AS DESIGN AND BUILT SITUATIONS



© SEDHAB



© Renata Gomes

FIGURE 34: (B) PEDESTRIAN CROSSING



© SEDHAB



© Renata Gomes

As seen in figure 34, it is extremely important to coordinate drainage and sewing systems in order not to jeopardize accessible strategies put in place.

CHAPTER

05

Case Studies

This chapter showcases ten case studies in different contexts to highlight adaptable solutions of universal design to slum upgrading, affordable/ social housing and reconstruction programmes. The case studies attempt to identify both successes and hurdles, pointing out ways in which these challenges have been overcome.

Context 1: Slum Upgrading

Rocinha (Rio de Janeiro/ Brazil)

The proposed slum upgrading of Rocinha, in Rio de Janeiro (one of the most well-known slums in the country, with approximately 130 000 inhabitants) was the result of a national competition held in 2005 and implemented during the years 2007-2008. With a total area of 143.72 ha, Rocinha is situated in a sub-basin zone presenting some flat areas, but mostly the land topography is very steep, composed of soil and rocks.

Sustainability features

Rocinha's master plan aiming to slum upgrading has defined actions for 10 years of intervention. Some of the relevant adopted guidelines are presented below:

- Opening / widening roads in dense and non-permeable areas in order to promote greater accessibility, greater social interaction and appropriation of public spaces;
- Prioritizing the allocation of public open spaces and small and medium-sized communal facilities, in the newly opened pathways within dense sectors;

- Ensuring that equipment and small and medium-sized public spaces at the local scale, have adequate accessibility and are close to housing units in order to minimize displacement of the local population;
- Creating peripheral circulation in the boundary between the community and the preservation zones. This strategy allows monitoring and preventing occupation towards the protected forest, encouraging urban sustainability in the community and at the city level;
- Adapting stairs, steps and local roads, alleys and pathways to the prevailing urban planning standards, attending accessibility regulations whenever possible.

Main specific interventions to increase accessibility

- Enlargement of “Rua 4” (4th Street), which originally was 60cm wide and had covered passages;
- Creation of an elevated walkway over the Lagoa-Barra Highway, connecting Rocinha to the São Conrado neighbourhood, designed as a gift by the Brazilian architect Oscar Niemeyer.

Challenges encountered

According to the project’s authors, the redevelopment of “Rua 4” had a positive impact on the lives of a major number of residents who used the narrow road down the hill to the Barcelos neighbourhood, along the Lagoa-Barra Highway.

In the original plan, the expropriations that were needed to widen the street were located on the opposite side of the actual road, in a more

precarious zone. It was planned to create an open space with buildings on stilts along the route. However, during the project’s execution, the contractor opted to pave the way along the hill, generating retaining walls and staircases as seen in figure 35. The decision was made due to budgetary constraints. However, despite the original project’s modification, the extension of 4th Street certainly provided benefits for all residents.

Discussion points

The original project proposed the installation of 10 funicular railroads to overcome significant height differences in the terrain. However, the State Government proposed to replace these railways by cable car, which meant more expropriations, higher implementation and maintenance costs. The local community initially rejected the idea, as they prioritized basic infrastructure services such as drainage, sewage and electricity.

FIGURE 35: ELEVATED PATHWAY, ROCINHA, BRAZIL



© Yann Artus-Bertrand

FIGURE 36: STREET 4 BEFORE AND AFTER THE UPGRADING PROCESS, ROCINHA, BRAZIL.

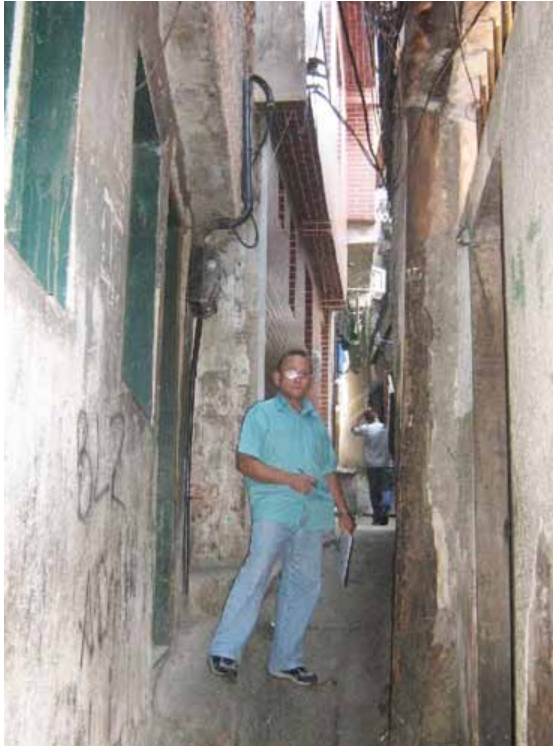

© Jonathas Magalhães

Proyectos Urbanos Integrales – PUI ("Integral Urban Project"), (Medellín, Colombia)

Violence, poverty and lack of formal transport, the last one aggravated by difficult topography, are issues that have affected the informal neighborhoods of Medellín since the second half of the twentieth century. Political will to solve these problems led to the creation of instruments of urban intervention called "Integral Urban Project" (PUI).

Concerning mobility and universal accessibility it is worth mentioning two of these projects. The first at the metropolitan scale is the *Metrocable* (cable cars) that is part of the PUI for the Northeast area of Medellín (*Comunas 1 and 2*); the second at the local level is the "Senderos de Conexión Independencias" project (electric stairs), which is part of the PUI in *Comuna 13*. These are two mobility systems at different scales but that coincide in their innovative spirit and the positive impacts that each one achieved on the social equity level.



Fundamental purposes of the projects:

- Adapting and increasing quality of public spaces, by improving streets and building parks and squares;
- Encouraging further pedestrian mobility, through elevated pedestrian walkways, vehicular flyovers and electrical stairs;
- Promoting housing programs through regularization, legalization, improvement and construction of mixed-use buildings.

Sustainability Features

Given the extreme rate of violence reflected in the informal neighbourhoods in Medellin (*Comunas* 1, 2 and 13) both projects focus primarily on the social aspect of sustainability. Accordingly, these are urban actions that use technology to facilitate public access to city services. Under the guidance of this principle, both projects successfully achieved two key objectives that improve the quality of life of thousands of people:

- Universal access and mobility provided for vulnerable people (children, pregnant women, the older persons, etc.) who live in hillside areas.
- Counteract the dynamics of insecurity in the area generating public space that breaks with the dynamics of violence.

Moreover, as a technical aspect, *Metrocable* uses solar energy for lighting the cabins.

Main specific intervention to increase accessibility

The installation of the cable car connecting distant points of the city improved residents' mobility and access to the main public transport system. Analysis carried out by the Inclusive Cities Observatory demonstrates positive results considering its continued use and increased accessibility to residents, workers and persons with disabilities in the region.

In *Comuna* 13, the 350 concrete steps (equivalent to a 10 story building) were replaced by sections of six double covered escalators. The 130 linear meters, lying between the base of the mountain and the highest part of the slope, provide the residents of the area with the possibility of returning to enjoy the benefits of the city. Some residents were previously "confined" in their homes, either because of their advanced age or disabling conditions

Challenges encountered

According to the Inclusive Cities Observatory, the most important challenges faced during the implementation process of the *Metrocable* were twofold:

- Lack of trust of the local community in the willingness of the government to complete the project;
- The condition of informal settlements is completely devoid of minimum urban planning hampering the construction or renovation of spaces: the housing restoration work had to face highly complex situations such as irregular, high-risk and inaccessible areas.

Discussion points

Notwithstanding the successful experience, it is important to assess up to which extent minor flaws in the complementarity of independent projects may affect accessibility: in some points, the size of the elevator's cabin did not allow assisted wheelchair users to be accompanied.

FIGURE 37: METROCABLE, MEDELLIN, COLOMBIA



© Nestor Fernando Lopez

FIGURE 38: ESCALATORS IN “COMUNA 13”



© Carlos Torres

Sources: Inclusive Cities Observatory. <http://www.uclg-cisdp.org/en/home>

Dávila, Julio D (ed) (2013), *Urban mobility and poverty: Lessons from Medellín and Soacha, Colombia*, London: DPU, UCL and Universidad Nacional de Colombia.

Aspilla, Yefer (2012), “Metrocable de Medellín: un servicio público de transporte ambientalmente sostenible y socialmente incluyente.” *Responsabilidad social y ambiental en los servicios públicos Volumen VIII, Número 1*, págs. 38-46.

Context 2: Large Scale Affordable Housing / Social Housing

Rwanda Demobilisation & Reintegration Commission housing scheme, (Rwanda)

Since its independence, Rwanda has experienced a history of extreme violence. This violence culminated in the 1994 genocide against the Tutsi people, that left at least one million Rwandans dead and thrice as many displaced. Although the

country has recovered, the Great Lakes region remains volatile, with several unresolved political issues especially in the neighbouring Democratic Republic of the Congo (DRC).

Aiming to contribute to the consolidation of peace in the great lakes region especially in Rwanda and eastern DRC, the Government of Rwanda established in 1997 the “Rwanda Demobilisation & Reintegration Commission” (RDRC). The commission mandate is to oversee the planning and implementation of the “Rwanda Demobilization

and Reintegration Programme” (RDRP)⁶³ for ex-combatants, especially the ones with disabilities, in recognition of the challenges they face in reintegration⁶⁴.

The Law no. 02/2007 of 20th January 2007 provides a residential house (for ex-combatants with disabilities in categories I and II⁶⁵), exemption from levies on government services, legal aid, free fare on public transport and also a monthly stipend for basic needs⁶⁶. As of May 2014, 544 housing units⁶⁷ had been constructed by the Commission.

Sustainability features

The programme succeeded in achieving social sustainability. As previously mentioned in Chapter 01, better accessibility leads to independence, participation in community life and entering the labour market.

A study undertaken between November and December 2011 by RDRP found out that for most of the ex-combatants with disabilities, housing was the single most important factor. The beneficiaries of the programme recognized the improvement on their living conditions, which in many cases went from desolate conditions in a Military Hospital to having a place they can call home. Additionally, the fact of being entitled to a house is a key element for reintegration of these ex-combatants with disabilities. The houses were equipped with water gutters and 2,000 litre tanks to harvest rainwater for different uses. The community members have benefited from jobs created during construction, and most materials used are locally produced; cement, sand, paints and rocks. The beneficiaries planted vegetables and fruits in the surroundings of their houses. The harvests improved their nutrition and self-esteem. Moreover, the canopy provided by the vegetables and fruits helped in environmental conservation.

Main specific interventions to increase accessibility

The housing units were designed with the support of international disability experts and standards for accessibility and reconstruction⁶⁸, based on low cost housing design from the City Council of Kigali, which would be suitable to the context and budget. The main interventions are listed below.

63 For more information, please consult: <http://demobrwanda.org.rw/home/> and <http://www.ncpd.gov.rw/index.php?id=105&elD...%26%238206%3B>

64 The Programme was supported by the World Bank and Multi-donor Trust Funds in its Stage II (2002-2008).

65 Ex-combatants with disabilities on Category I are those with a permanent disability rate between 90% to 100% impairment. They include paraplegics, double amputees, total visual impairment, and severe mental retardation. Ex-combatants on category II are those with a permanent disability rate between 70% to 89% impairment. They include above knee amputees.

66 In 2011 the monthly stipend was 50,000 RWF (category I) and 35,000 RWF (category II) respectively equivalent to 82\$ and 35\$ US Dollars.

67 The average cost is USD27000 for a special house and USD21000 for a standard house. While the World Bank has financed construction of houses for Category I, the houses for Category II have been fully financed by the Government of Rwanda from its annual budget. The Government of Rwanda has integrated this in its annual budget as provided by law.

68 (Urban Management Department of the Lebanese Company for the Development and Reconstruction of Beirut Central District (SOLIDERE), United Nations Economic and Social Commission for Western Asia (ESCWA), 2003-2004), (The Sphere Project, 2011) (Stakes for the United Nations, 2003)

- Accessible entrances through ramps;
- Lower windows and glazed entrance doors to allow visibility from wheelchair;
- Kitchen and bath with clear area, and adapted counter height for wheelchair manoeuvrability and accessibility;
- Barrier free washrooms with grab bars and hand-held shower;
- Doors with minimum width of 1.00 m and handlers lever style;
- Electrical fittings too are counter height adapted.

While all the houses are barrier-free, housing for ex-combatants under Category I can be split into five design plans:

Plan 1- urban special house: a self-contained, two-bedroom house designed for a wheelchair user.

The doors and windows are designed and fitted accordingly. The toilets and showers have support fittings. The kitchen is dimensioned to allow the wheelchair user to use it without difficulty. This house is provided with an extra room for an in-house caretaker, who could be a relative in most cases.

Plan 2- rural special house: this house has all the features of Plan 1, but with an exterior pit latrine, shower and kitchen, to be managed without flowing water.

Plan 3- Standard urban: two-bedroom house with standard features, including plumbing for running water.

Plan 4- same as plan 3, but with exterior pit latrine, shower and kitchen manageable without flowing water.

FIGURE 39: BARRIER FREE WASHROOMS



© RDRC

FIGURE 40: LOW WINDOW AND EXTERNAL DOOR WITH GLAZING TO ALLOW VIEW FROM WHEELCHAIR



© Harald Hinkel/World Bank

Sources: Rwanda Demobilization and Reintegration Commission, *Impact Assessment of Health Insurance, Housing, Monthly Allowances and Other Entitlements for Ex-Combatants*, July 2012.
<http://demobrwanda.org.rw/home/>

For ex-combatants with disabilities under Category II, a “**Plan 5**” was developed: three bedroom standard house. More rooms were added in this typology than in Category 1, due to relatively bigger families accompanying beneficiaries in Category II.

Challenges encountered and solutions provided

After the construction, RDRC has to cater for periodic inspection and maintenance of the houses due to limited financial capacity by the occupants. The houses are generally repaired by RDRC. In a number of cases the beneficiaries have taken initiative to manage minor repairs by themselves.

It is important to highlight that appropriate land acquisition in Rwanda is a challenge, but

accessibility was considered from the beginning of the planning and land selection process: access to public transport, location, proximity of adequate health facilities, public water and power supply connection, etc. Nevertheless, most of the housing estates are found on slopes and are affected during the rainy season by runoff rainwater. To address this issue, RDRP has constructed drainage and provided water tanks. The programme is planning to pave an “accessible route” in the compounds to ease movement of wheelchairs, as they get stuck in the mud, especially during the rainy season.

Replication

The model implemented in Rwanda was later implemented in Burundi: houses for ex-combatants with disabilities are being built now.

Sustainability features

Buildings were designed with passive strategies as cross ventilation and sun shading devices to prevent excessive heat gain.

Challenges encountered

The project was designed to benefit from the steep terrain. Through this strategy, it was possible to locate the main entrance of the buildings in their intermediate levels and avoid the use of elevators, saving costs still in compliance with local regulations. The municipal building code establishes that elevators should be used to provide access to buildings with more than four levels upwards or downwards the main entrance. However, during implementation, the municipality required the project to be modified for the provision of future installation of elevators to enable access to all floors.

Discussion points

Nowadays, the Brazilian legislation requires, for this kind of development, 100 per cent of the units designed in compliance with accessible and universal design standards, providing similar benefits to all users. This initiative will also give the people the possibility to stay in the same house when reaching old age or in the situation of acquiring an impairment due to an accident.

There is a controversy surrounding actual mandatory local standards. Some building professionals defend that current regulations requirements for 100 per cent accessible housing are unfeasible. They state that “accessible units” use more space, lead to increased costs, hinder the complete exploitation of the built area and do not reflect the real present need of the community. The same debate arises at the mandatory installation of elevators as its implementation and maintenance costs will not always be feasible for low-income dwellers.

A compromise should be reached since a house - a home, to be sustainable, should not only reflect the instant need of a community as it is a long term good. It should also provide for future and unpredictable needs.

FIGURE 42: SCHEMATIC DRAWING WITH RAMPS AND STAIRCASES

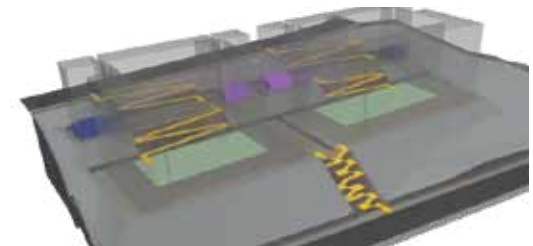

© Marcos Boldarini

FIGURE 43: RAMPS AND STREET VIEW



© Daniel Ducci

Masoro Village Project (Masoro Sector, Rwanda)

The Masoro Village Project⁷¹ was envisioned as a capacity-building endeavour that would enable the people of Masoro Sector in Rwanda to build homes independent of designers and contractors. The first house (“Masoro House 01”), built in 2013 became a laboratory for testing and teaching both established and novel building techniques. The second house (“Masoro House 02”), exploring multi-level construction is scheduled to break ground in 2014. As a result of this project, a new community organization, Association Icyerekezo, was created to centralize and disseminate design and construction knowledge for current and future homeowners/ builders.

Main specific interventions to increase accessibility

In partnership with the Association Icyerekezo and students from the Kigali Institute of Science and Technology (now the University of Rwanda), a series of design workshops took place to discuss the domestic habits and social dynamics of Rwandan culture. This provided consensus for key design features in the Masoro Village House that was completed in 2013. Workshop participants were encouraged to formulate an ideal home layout - it was during this design process that the final house layout was developed.

⁷¹ Designed by GA Collaborative.

Main Design Attributes⁷²:

- An exterior corridor allowed bedrooms to be well ventilated and easily accessible from the outside;
- A covered roof along the corridor allotted additional shaded outdoor space;
- Doors provided a minimum 914 mm clearance, with no door thresholds;
- Walls were laid out to reduce sharp turns, especially in tight interior spaces;
- Kitchen counters were approximately 600 mm deep and installed no taller than 1120 mm to facilitate wheelchair accessibility;
- There was a 1525 mm diameter clearance to allow wheelchair manoeuvring in both the kitchen and shower;

Sustainability features

The designers introduced the concept of *Earth Bag* construction, the first application of its kind in Rwanda. *Earth Bags*, originally developed as a military bunker construction technique, are woven polypropylene bags packed with sifted soil from the site and used to form stable, load-bearing walls. The walls and floors were finished with a mixture of sifted site soil and cement, though mud plastering would have been preferable. Eucalyptus trees were cut, dried and applied as floor and roof beams. And lastly, a corrugated sheet metal roof was fitted with gutters leading to a rainwater collection tank.

The intention of the designers was to develop a building construction methodology that utilized as much locally sourced materials as possible; available in dimensions that required only a few workers to handle without mechanical assistance.

A one-month long workshop allowed many of the Association builders to have an opportunity to be exposed to all phases of the construction process. Whether low- or high-skilled, man or woman, everyone was encouraged to engage in all aspects of the housing construction. Responsibilities that were commonly retained for men - for example, roofing - were performed by both men and women in the Association.

Challenges encountered / lessons learned

The selection of available sites and infrastructural provisions by the municipality were limited for the Masoro Village Project. Though Masoro House 01 itself is accessible, its location, situated on a steep slope from the main road, made accessibility to the house challenging for those with limited mobility. The Masoro House 02 is designed to overcome the challenges of the hilly terrain (see fig 46), and provide greater ease of access. Additionally, designing a two-story house addressed the pressing issue of land scarcity in Rwanda and introduces new construction techniques to Association icyerekezo's knowledge base.

⁷² Designed with accessible features using the federal guidelines established by the Americans with Disabilities Act in the United States as a model.

The project has had wide support throughout Masoro where villagers are now planning additional *Earth Bag* buildings and teaching others these new construction skills. Enabling self-building practices allowed Masoro villagers to build their

own homes, taking control of the design and construction process, and allowing for constant customization for their growing needs. During the design sessions, everyone was encouraged and assisted to design their homes.

FIGURE 44: EARTH BAG CONSTRUCTION



© GA Collaborative

FIGURE 45: MASORO HOUSE 1



© GA Collaborative

FIGURE 46: MASORO HOUSE 2: A BRIDGE CONNECTS THE TWO-STORY BUILDING TO THE UPPER PORTION OF THE SITE

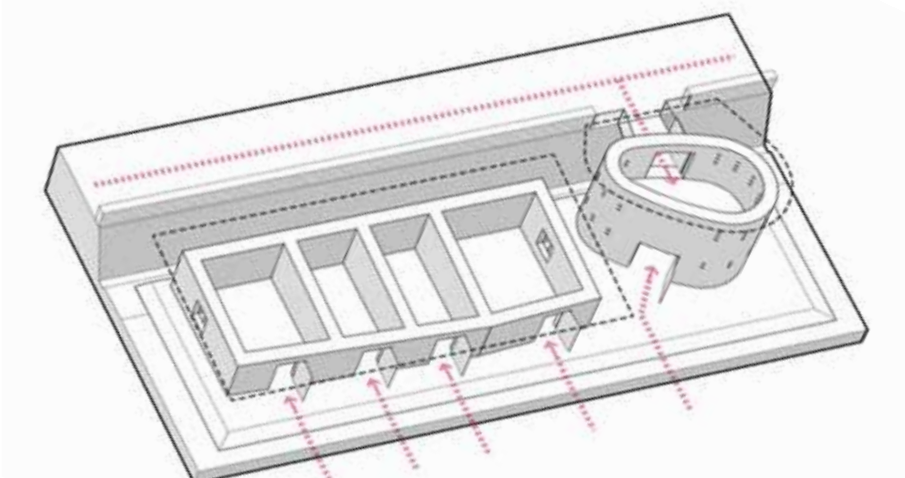

© GA Collaborative

Context 3: Reconstruction

Houses for persons with disabilities SCIPPER, PAKSBAB (Pakistan)

The Spinal Cord Injury Project for Pakistan Earthquake Rehabilitation (SCIPPER)⁷³ is a humanitarian network to rehabilitate people who became paralyzed from spinal cord injuries sustained during the 2005 earthquake. Most of them are women and children.

To date the SCIPPER⁷⁴ / HF initiative has built 11 homes, which are adapted for mobility-impaired people in the very challenging Himalayan terrain. Seven homes have been built using traditional methods. Four houses have been built with PAKSBAB (Pakistan Straw Bale and Appropriate Building) technology, and therefore they are energy efficient and earthquake safe. PAKSBAB is currently beginning the construction of the 5th house.”

Sustainability feature

PAKSBAB makes use of local labour and indigenous renewable materials for construction of the houses, involving the family members in the building process.

The housing project is a single-story structure built on a concrete slab, and comprises of two rooms and a kitchen, restroom and veranda. The exterior walls are made of straw bale (total thickness of approx.

0.40m); the kitchen and other interior partition are wattle-and-daub walls, with exception of the concrete block walls of the bathroom. Additionally, the roofs are on-site-built with wood trusses and covered by corrugated metal sheets.

The houses are provided with a septic tank and gutters for rainwater collection. They are connected to the electricity grid and have water connection or a well.

Main specific interventions to increase accessibility

- During the process, each patient and the family were consulted regarding specific needs and necessary adjustments were made to adequate topography and local conditions.
- Whenever possible, the houses were built close to a road, to enable residents’ displacement from their homes to medical facilities whenever necessary.

Wheelchair accessible features:

- Kitchen and bath have 5’ diameter (approx. 1.50m) clear area for wheelchair manoeuvrability;
- Wheelchair accessible counters and low storage in the kitchen;
- Electrical switches and outlets within wheelchair reach, but out of reach of children;
- Wheelchair accessible corner sink in the bathroom;
- “Western toilet” with grab bars;
- Overhead or hand-held shower;

⁷³ SCIPPER’s work is implemented in Pakistan by Hashoo Foundation (HF) which is a non-profit organization registered in Pakistan, the USA and the UK.

⁷⁴ For more information: www.scipper.org; www.paksbab.org; www.hashoofoundation.org

- Doors with minimum width of 3' (approx. 0.91 m);
- No door thresholds;
- Windows operable from the wheelchair;
- Wheelchair assisted access ramps;

Challenges encountered

- Due to wheelchair accessibility features, an adapted design may imply a 5 per cent increase in cost (for ramps, grab bars, hand-held shower, additional “western toilet” in the bathroom, larger bathroom door, and kitchen modifications).

- It is difficult to find affordable flat lots near a road; therefore the lots are often sloped, requiring retaining walls and/or infill.
- Sometimes it’s challenging to provide water and electricity access if utilities are not already nearby, and to motivate the family to get involved in the building process.

Feedback of local people reports that **“The homes have had a huge impact on the quality of life of the patients”** and that they have **“increased the longevity and survival of the patients by making their environment healthier.”**

FIGURE 47: NOOR JEHAN HOUSE, (EXPOSED STRAW BALE UNDER PLASTER)



© PAKSBAB

FIGURE 48: NOOR JEHAN HOUSE, (RAMPED ACCESS UNDER CONSTRUCTION)



© PAKSBAB

FIGURE 49: SAADIA NOOR HOUSE,
(ADAPTED KITCHEN)



© PAKSBAB

Villa Verde/ PRES Constitución (Constitución, Chile)

The Plan for Sustainable Reconstruction (PRES Constitución) is a master plan developed after the 8.8 Richter scale earthquake and tsunami that hit Chile in 2010, which almost entirely destroyed Constitución. As it is a coastal zone, the aim of the master plan was to rebuild the city in a way that would also resist future tsunamis. On the other hand the Plan for Arauco Forestry Workers, commissioned in 2009, was developed within the framework of the current national housing policy for Solidarity Housing Fund I and the Solidarity Housing Fund II (units up to 25,000 USD without debt and units up to 40,000 USD with bank loan, respectively). It estimates 9.000 housing units to be built in 30 locations, within cities and towns

FIGURE 50: KULSOOM BIBI HOUSE,
(ADAPTED BATHROOM)



© PAKSBAB

with 10,000 to 20,000 inhabitants. The Villa Verde project was designed by “Elemental” and commissioned by the forestry company Arauco, as part of the pilot housing projects coinciding with the PRES Constitución framework, building 484 permanent residences to the company’s workers and people affected by the 2010 catastrophe.

Sustainability features

The PRES master plan was developed with a comprehensive approach, which comprises mobility and modal diversification strategies, rainwater and anti-tsunami plan (ground surface runoff network, creek and stream channelling, mitigation park, evacuation routes). Developers’ field experience has shown that conventional infrastructure is ineffective for resisting the energy of displaced water; hence the strategy comprises an evacuation plan, a coastal forest able to produce enough friction to reduce the energy of the waves instead of trying to resist them and a conditioned building zone with collapsible enclosures in the lower levels. The topography of the forest terrain



had to be rough and bumpy to maximize resistance and optimize the area allotted for housing. The master plan addresses equally the energy issue, providing a heat recovery plant (for public buildings and seasonal pool), resource management (sorting plant and biogas recovery RSU) and passive solar housing with solar water heater panels.

Villa Verde units' structure and roof structure were built with local wood⁷⁵ (structural timber), minimizing carbon footprint due to reduction transport distances and generating income to the local market. The area is the second wood producer centre of Chile. The construction also includes solar water heater (SWH) systems, as seen in figure 55, as part of PRES guidelines.

The designers applied the concept of “incremental housing”⁷⁶, which is the provision of space and infrastructure for units' future expansion and impersonation by the residents themselves. In less than a week from the project's inauguration, almost all of the units had added new rooms, achieving right away a middle class standard, but also increasing each individual unit's market value, transforming the housing subsidy into an investment and not just a social expense.

75 *Builds in Chile must follow NCh 433 Standard for Seismic Building Design, and is important to notice that the structural timber was one of the most resistant building materials during the 2010 earthquake.*

76 *Evidence shows that a middle class family can live reasonably well in around 80m², while public resources in Chile can finance 40m². The strategy adopted by the designers was to deliver the half a family would never be able to do on their own individually, prioritizing more complex components (localization, placement of the house in the lot, collective spaces, structural design considering future expansions, etc.) with higher standards both for the initial and the final scenario. “Elemental” has been applying the “incremental housing” concept for ten years.*

Main specific interventions to increase accessibility

Attending future residents' requests, four units (0.8 per cent of the total built houses) were adapted following universal design principles of wheelchair accessibility. The same ordinary housing typology had the layout modified to provide one adapted bedroom, bathroom and kitchen at the ground floor, with ramps for all access (the original typologies have no bedrooms on the ground floor). The project follows the Supreme Decree 49 (Housing and Urban Development) that establishes minimum dimensions for persons with disabilities, and was certified by the Preventive and Medical Commission (Comisión Médica, Preventiva e Invalidez – COMPIN).

The bathrooms were enlarged to allow wheelchair maneuvering (rotation) and are provided with grab bars, adaptable shower heights, folding chair allowing sitting bath. Widen doors with horizontal lever handle to facilitate opening are used in the whole house. The access and exit to backyard ramps are 1.5m wide with a maximum slope of 12 per cent.

Challenges encountered

The level of accessibility and also the amount of houses adapted were restricted by the available budget. Each modified unit had an additional grant of 20UF (approx. 850 USD), given by COMPIN for adaptation purposes.

FIGURE 51: DIFFERENT PHASES OF INCREMENTAL HOUSING



Photos by Suyin Chia and Cristian Martinez © ELEMENTAL

FIGURE 52: GROUND FLOOR PLAN-ADAPTED UNITS WITH ACCESSIBLE GROUND FLOOR

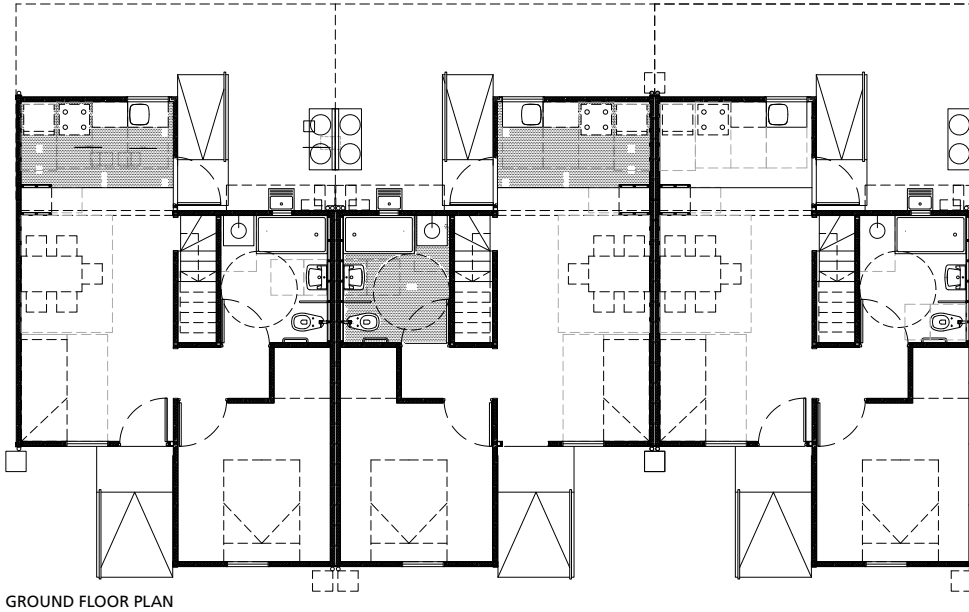

© ELEMENTAL

FIGURE 53: ADAPTED HOUSES WITH SHW SYSTEMS



Photo by Cristian Martinez © ELEMENTAL

Accessibility of Older Persons

Accessibility of Older Persons to Public Housing: the case of Thailand

Thailand's population has been rapidly aging since 2005. According to "Population Estimation 2010-2040" by the office of the National Economics and Social Development Board of Thailand, almost 40 per cent of older persons live in urban areas and this quota will increase to 50 per cent in 2020 and almost 60 per cent in 2040. For the past few decades, Thailand has increased efforts to elevate quality of life of older persons and persons with disabilities. At present, the government is

implementing “The 2nd National Plan on Older Persons (2002-2021) 1st Revised of 2009 ” aiming at improving the quality of life of older persons and persons with disabilities by motivating their families and communities to take care of these groups first and foremost with welfare services provided by the Government as a supporting system.

The two cases presented in this sub-chapter are an initiative of the National Housing Authority (NHA) with different partners.

- ***Baan Eua Ar-thorn Bungkhum Housing Project, Bangkok*** (*Housing for low-income people in urban areas*)

Baan Eua Ar-thorn Housing Project⁷⁷ is part of a home-ownership scheme that enables older persons and persons with disabilities to have access to housing. “Baan Eua Ar-thorn Bungkhum Housing Project” was completed in 2006 and comprises of 5,872 housing units with an effective population of 30,000 inhabitants. The number of older persons people is estimated at around 20 per cent. Dwelling units were provided with appropriate facilities i.e. community centre, market, inclusive playground and recreational space, park, sports field, etc. to increase quality of life. The mixed-generation in the project was also an intention to enable older persons to feel part of a community rather than being separated in nursing homes.

FIGURE 54: TYPICAL RESIDENTIAL BUILDING IN BAAN EUA AR-THORN. RAMPS AND HANDRAILS WERE PROVIDED IN EVERY BUILDING



© Sukumaporn Jongpukdee/NHA/Thailand

Discussion point

Even though NHA planned to allocate dwelling units on the ground floor to older persons, the initiative failed during the implementation phase. An increased effort to allocate older persons and their family to proper dwelling units (i.e. ground floor) is still required.

⁷⁷ The Baan Eua Ar-thorn Housing Project was part of a Government policy in 2003 to deliver low-cost housing to low-income households not exceeding 15,000 Baht per month (around 460 USD). The price of the dwelling was 290,000 Baht (8963 USD) for a 24-square-meters unit and 390,000 Baht (1253 USD) for 33-square-meter unit.

▪ *Baan Sabai Phue Yai and Ta. (Housing for poor older persons people in rural areas)*

Baan Sabai Phue Yai and Ta is a rural area housing renovation or housing reconstruction programme⁷⁸ based on the concept of “Aging in Place”, on land owned by older persons. The participatory approach includes meetings between NHA, the Local government and the community to identify suitable older persons and persons with disabilities who need assistance. In a second phase, a survey of existing conditions of the target group’s housing (measurements, interviews and observation of their behaviour) is held and then urgent needs and conditions are prioritized. Community people are often requested to assist in building a house as social responsibility activities.

FIGURE 55: (LEFT) ADAPTED TOILET IN CHIANG MAI PROVINCE



©Angkarn Sakkaranukit/NHA Thailand

FIGURE 56: (RIGHT) TOILET IMPROVEMENT WITH HANDRAILS AND BATH CHAIR



© Teera Kaengthonglang/NHA Thailand

The housing improvements are related to the structure of the house, staircases/ramps, changing flat to flush toilet, installing handrails in toilet, reorganization of internal partitions, improvement of natural ventilation, etc. In some severe cases, a new house is designed to replace the deteriorated one.

In some cases, handrails made of local materials were provided to facilitate toilet use for older persons refusing to use flush toilets. A bath chair made of a concrete block and wood was also provided.

⁷⁸ The budget mainly comes from NHA as a grant and partly from Ministry of Social Development and Human Security and Local Government.

FIGURE 57: FLAT TOILET AND BATH CHAIR PROVISION WITH HANDRAILS



© Thanapat Arnmanee/NHA Thailand

Since the programme was initiated in 2010, NHA with its network has been renovating and building more than 62 houses in Petchaburi, Chaimai, Ubonrajchathani, Rayong provinces. Additional 100 houses shall be completed in 2014. The goal is to renovate and construct 500 houses for older persons and persons with disabilities around country within 5 years. The cooperation will be strengthened by involving educational institutions such as Architectural Schools in the design process.

Sustainability features

The main goal of the programme presented here is to allow older persons to live their life in their own community with their relatives and neighbours rather than spending their last period of life with strangers in nursing homes. Consequently, the government's budget saved on care services is redirected to build nursing homes whereas the

community would take care of older persons and persons with disabilities themselves.

Sustainability is concurrent with the participatory process and strong ties among stakeholders in implementing the project. A crucial factor to the success of the project was the use of indigenous building materials and the mobilization of local resources, combined with the expertise of stakeholders.

Lessons Learned

To facilitate access to housing for the older persons and persons with disabilities, governments should provide different housing programs to suit their affordability and preferences. In some cases, housing grants and financial subsidies can be provided. For low-income older persons or families including older persons, public rental housing



can serve as a safety net or first step in housing the latter. Some measures i.e. priority of allocating housing for older persons people is also needed to ensure that older persons people or households including older persons members can get proper dwellings, suitable to their physical conditions.

Social Innovation, Public Policy and the Improvement of Senior Citizens' Housing Condition: The Case of Aged-friendly Housing Project in Shanghai⁷⁹

Shanghai has become the first 'aging city' in China, due to the combination of high life expectancy and low fertility rate, indicating a serious aging problem among registered citizens. By the end of 2012, there were more than 3.67 million residents in Shanghai above 60 years of age, accounting for 25.7% of the city's total population.

Most of the houses occupied by older persons lack proper access facilities. An inappropriate housing design inappropriate for seniors' needs and out-dated facilities such as exposed wirings and slippery floors may bring potential safety hazards and limit mobility.

The 'Shanghai Aged-friendly Housing Project'⁸⁰ was developed to assist the government to address the growing need of age-friendly houses for older persons, especially those in low-income communities. The experimental stage (2010-2011) mobilized one million RMB (approx. USD 160.000), which benefited 50 low-income aged families in Yangpu District, Zhabei District and Huangpu District in Shanghai. These areas concentrate a relative large low-income aged families and also old apartments.

The project has three main aspects:

1. **Age-friendliness:** paving with anti-slippery floorings; installing grab bars in bathrooms and on both sides of toilets; readjusting the width of doors and windows; and adapting the height of kitchen counter tops to the needs of home partners.
2. **Safety:** replacing out-dated or exposed electrical wires; installing new and safe sockets; replacing rusty or damaged water pipes and gas pipes; changing broken door locks; changing broken windows; and changing used appliances such as water heaters and gas stoves.
3. **Practicality:** renewing old water taps; replacing light bulbs with energy-saving models; repainting walls, window frames and doors; and providing extra cabinets.

⁷⁹ Social innovation projects are usually initiated by NGOs. Once their effectiveness and social impact are clear, governments and corporate resources are attracted and sometimes they even adopt these projects as public policy. The Aged Friendly Housing Project in Shanghai is a successful example that has been adopted by public policy decision-makers benefiting the majority of low-income senior citizens.

⁸⁰ The project was proposed by Habitat for Humanity China. HFH China is in charge of fund-raising, drafting detailed implementation plans, and organizing volunteer activities. Shanghai Senior Citizens' Foundation works in coordination with the local government to provide a list of candidate families among which that HFH China will then select beneficiaries of the project.

FIGURE 58: PROPOSED IMPROVEMENTS TO MS. FEI LANYING HOUSE, IN YICHUAN COMMUNITY IN PUTUO DISTRICT, SHANGHA

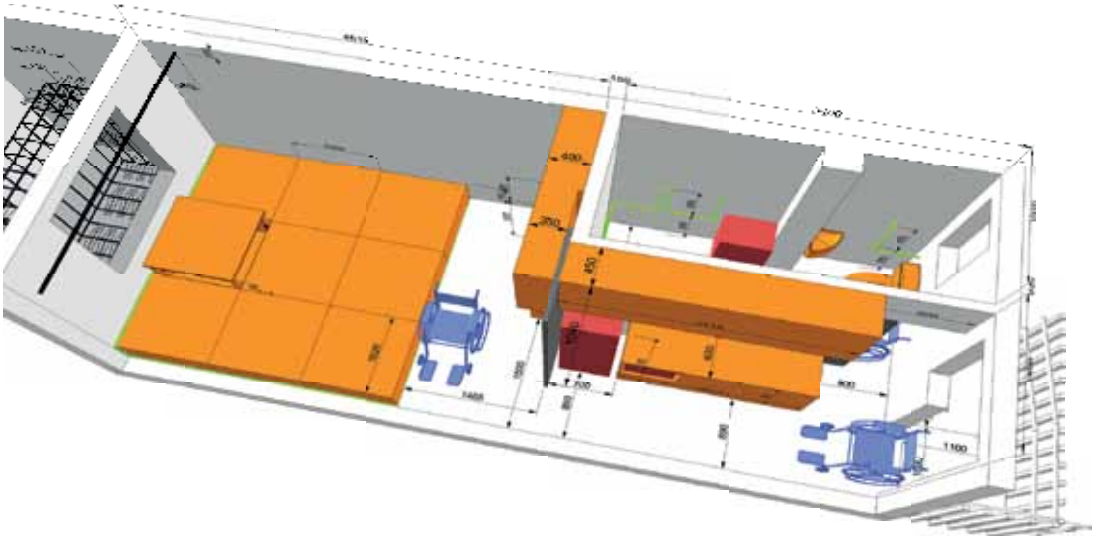

© Habitat for Humanity

To be entitled to benefit from the project, older persons should meet all the criteria specified below:

- 1. Age and family support:** senior citizens must be over 60 years old, without financial support from other family members; priority are those that depend on wheelchairs or with disabilities;
- 2. Financial condition:** low-income families who rely on governmental minimal living allowance;

- 3. Housing condition:** those who live in dilapidated apartments;
- 4. Willingness:** those who are willing to accept HFH China's help as well as volunteers' participation in the renovation process.

Sustainability features

Testimonials demonstrate that once socially isolated people are now proud of their home and invite friends and relatives to visit, contributing to sustainability under its social and cultural aspects.

FIGURE 59: BATHROOM WITH UPGRADED FACILITIES INCLUDING A GRAB-BAR FOR ACCESSIBILITY



© Habitat for Humanity

Replication

Shanghai's City Government decided to adopt this project as one of the major Public-benefiting Projects for 2012 and beyond. Every year about 1000 low-income senior citizen will benefit from the programme, sponsored by Shanghai Social Welfare Lotteries fund. In 2012, the project was carried out in nine central districts in Shanghai, implemented by 14 social organizations and benefiting 1005 families.

Main specific interventions to increase accessibility

- Replacement of slippery flooring;
- Installation of grab-bars in the toilet;
- Installation of handrails to minimize the risk of slipping when using the toilet or shower area;
- Opening narrow partitions, doors and corridors to allow wheelchair access and natural lighting;
- Adapting the height of kitchen counter tops.



CHAPTER

06

Gap Analysis

This chapter contains an analysis of the most significant gaps on the implementation of accessibility of slum upgrading, social housing, large-scale affordable housing and reconstruction programmes encountered during the elaboration of this publication. The gaps refer to accessibility in public, private and residential spaces and buildings, from the social, financial, normative and technical aspects. The chapter also starts a discussion on how to address these gaps leading to further reflection.

As in any other development, the gaps between projects, policies, design, implementation, enforcement and users' acceptance is undeniable. To overcome ineffective situations in different aspects of the programmes analysed in the contexts of this publication, some inconsistencies must be carefully addressed. The sustainability of these programmes relies on filling the gaps in an acceptable timeframe.

- **Gap: Policies are often disconnected from law and state obligations.** This is for instance the case when contracting international obligations (like human rights, CRPD) but not taking the necessary measures for implementing them progressively, with maximum available resources and indicators to assess progress.
- **How to address it:** apply a human rights based approach (HRBA) to policies and programs.⁸¹
- **Gap: Policies are often disconnected,** as they are usually subject specific (accessibility, sustainable construction, reconstruction) and seldom make reference to each other. Housing issues of poor people are often addressed as poor quality housing: poor standards, remote locations, little consideration to lifestyles and

⁸¹ For more information on Principles and elements of HRBA: please consult <http://www.ohchr.org/Documents/Publications/FAQen.pdf>



livelihood strategies.⁸² Sometimes housing policies overlap or they are even contradictory. Building and urban planning professionals should not need to comply with contradictory housing policies. Contradictory housing policies highlight the vulnerability and inconsistency of governance and policy frameworks and should be developed.

- **How to address:** Policies are to be subject specific, but they should be conceived or reviewed in an integrated way. They should be used together and complement each other. A consistent policy framework goes beyond technical issues and also includes social, cultural, environmental and economic aspects. Better results can be achieved when policies are developed or analysed by a multidisciplinary group. “Having an integrated scope must be a priority for all government levels, which call for wide-ranging scopes that adopt a multi-sectorial, urban socio-environmental approach.”⁸³
- **Gap: There is often a lack of funds during implementation** due to underestimated costs or amount of work; inexistent or superficial risk analysis or delays resulting from changes in the project due to lack of compatibility in complementary projects. A low capacity of negotiating for financing within different governmental spheres, also affects project’s budget and quality.
- **How to address:** It is essential that the project’s implementation is properly connected to the local cultural, economic, social and environmental conditions including the physical and geographic site conditions, in order to avoid

lack of funds during implementation: there must be a careful analysis of the total amount of investment in place before the implementation of the project starts, including the consideration for earthworks such as excavation and for accessibility adaption costs. This is especially important when replicating housing patterns in a mass housing development.

- **Gap: Lack of compatibility of different projects**, due to insufficient communication and coordination between the various actors involved in a project. It quite often jeopardizes accessibility initiatives and compromises the sustainability of the whole programme. Examples of lack of coordination are: placement of light poles and telephone booths in front of curb ramps, placement of uneven sewage grills in accessible routes, etc.
- **How to address:** Every single human settlement requires basic infrastructure and services. From the very early stages of the project, different schemes must be made compatible. The municipality or the concessionaires responsible for lights, phones, water, plumbing, landscaping and other amenities should be part of the project team, or at least consulted and informed during the whole planning process. This will bring not only an improved and inclusive environment but will also save costs as it avoids double work to correct mistakes.
- **Gap: Bad quality of execution** of a project often happens when budget priority is elsewhere or when there is not enough monitoring during the construction/implementation phase. Lack of awareness and technical skills of the professionals involved or the use of inappropriate building materials are also a source

82 (UN-Habitat, 2012)

83 (UN-Habitat, 2012)



of bad quality in projects. Moreover, bad quality may be a consequence of differing opinions related to priority levels in defining policies or negotiating for housing finance within the different governmental spheres. Sometimes it is also a result of a non-participatory design, planning and implementation process.

- **How to address:** Technical standards, when properly adopted and implemented might help to overcome some quality related issues. However, supervision by a qualified professional during the project implementation is crucial for good execution. In case of self-construction, construction groups might help families with less capacity. On-the-job training and judicious selection of partners also plays an important role on the final results. Last but not least, it is crucial to invest in building technical capacity and understanding of professionals (designers, architects, engineers, building practitioners) and policy makers on the different aspects of sustainability, passive climate adaptive solutions and on the importance and technical aspects of accessibility.⁸⁴
- **Gap: Post implementation abandonment,** which often occurs when the community is not involved in key stages of the project development such as decision-making, design and implementation. In these cases, the appropriation of space by the community hardly happens. After implementation of the project, when the public administration or the organizations implementing the projects typically move away, accessible routes and solutions are left behind to the detriment of their own community. Opting for solutions

that require high maintenance costs or high technology features are also a cause of post-implementation abandonment.

- **Misdiagnosis of priorities,** which can be influenced by various aspects: different interest of stakeholders, restrictions of resources (financial, technical, time) or unawareness of decision makers. Choices frequently do not reflect the community's priorities, leading to results that will not be accepted or used.
- **How to address:** A participative approach, when well managed and implemented brings benefits both to the community and to the project developers. It bridges gaps and when undertaken as a continuous process, leads to continuity. As participation creates informed and responsible citizens, it allows sustainability to be addressed in its four spheres: social, environmental, economic and cultural. Community members know more than anyone the challenges they have to face in their day-to-day life and might play a crucial role in setting priorities. It is also important to align community priorities with the governmental priorities and to raise awareness in order to create a sense of ownership.

84 (Inter-American Development Bank, 2012)



CHAPTER

07

Key Findings and Recommendations

This chapter lists key issues identified while approaching the topic of accessibility in slum upgrading, social housing, large-scale affordable housing and reconstruction programmes. It proposes strategies to trace priorities in the search for effective and sustainable solutions.

Even after the removal of physical barriers, negative attitudes against disability still remain. To overcome the ignorance and prejudice surrounding disability, education and awareness raising are required. Such education should be a regular component of professional training of architecture, construction, design, informatics, and marketing. Policy-makers and those working on behalf of persons with disabilities need to be educated about the importance of accessibility.⁸⁵

Beyond gaps, it is important to highlight some recurrent issues found during the research process of this publication.

- There is a real lack of attention to specific needs of vulnerable groups (persons with disabilities, older persons, children, women, etc.) in many slum upgrading, reconstruction and mass housing programmes. These groups are merely considered as part of “the poor” and this concept only contributes to increase their vulnerability and social inequity.

⁸⁵ (World Health Organization and World Bank, 2011)



- As a consequence, a great number of social housing and affordable housing projects investigated under the scope of this handbook presented relatively good architectural solutions, but unfortunately suffered from a complete absence of accessible strategies.
- The key is therefore to work with awareness raising and capacity building of decision makers and building professionals.
- When addressing vulnerable groups such as persons with disabilities and the older persons, especially in low-income contexts, there is no solution that will fit in all instances. Universal design is one important tool but it does not replace efforts to embrace health issues, cultural boundaries and social aspects as poverty alleviation, religion, and job creation.
- The same works for climate responsive strategies: there is no general approach. It is the responsibility of the building professional to develop a climate response strategy according to local climatic characteristics, standards of comfort, cultural acceptance of certain building materials, the different proportions of sources of energy available (regional energy mix), and environmental impacts. These criteria are potentially useful for the assessment of building material and design options for efforts to establish sustainable low-cost housing in developing countries. Generally, successful indigenous building methods and specific techniques that have traditionally served the needs of the people in terms of comfort, safety and durability should be integrated with advanced design tools for optimizing energy conservation and building performance.⁸⁶
- It is common, especially in developing countries, that political priorities prevail leading to interventions designed for a short-term solution and not for a continuous process of development. Infrastructures as drainage and sewage or educational and social components are often replaced by “visible public works”. It is unfortunate that all goes down in the first rainy season.
- Although it is possible to adapt existing standards and codes already in use in more developed countries, governments should make an effort to effectively address specific demographic needs: policies must be regionally specific. They should aim to attend the greatest number of the least advantaged first, and improving overall building safety and performance over time, as larger numbers of the least advantaged gain improvements in their living and working situations.⁸⁷
- It is important to understand how networks can be strengthened and replicated, aiming at resource mobilization and support for local action.
- It is essential to physically link projects with public transportation, basic infrastructure, social and commercial facilities. Otherwise what is created in a segregated community and in a long term perspective new problems will arise.

86 (UN-Habitat, 2011)

87 (UN-Habitat, 2011)



What to prioritize

At first, at Government scale, States need to **adopt adequate legislation to address their obligations** in the areas covered by this publication. The application of standards and construction guidelines on housing, infrastructure and public spaces are examples of effective tools to be implemented. Subsequently, the development of policies and adequate allocation of funds using States' maximum available resources (including through international cooperation). It is likewise important to develop indicators to assess progress.

The elements described in the next paragraphs may support new or upgrading existing policies

When resource restrictions limit the number of accessible solutions, it is recommended to **undertake a public consultation** and identify the number of persons with disabilities and the type of impairment to establish priorities. It is important to consider, however, that the absence of residents with special needs (be it a mobility impaired, blind or deaf person, or even a senior citizen) in the moment of planning is very likely a temporary situation. As mentioned before, everyone is susceptible to face the condition of being physically impaired at some point in his or her lives.

It is equally crucial to establish an **acceptable list of priorities**, developed by the project management team, and validate it with the community. The reasoning behind any decision making process would be as follows: prioritize basic structural and low maintenance cost solutions over cost-increasing solutions such as deployment of lifts, funicular railways, cable cars. Before adopting such strategies, an assessment of the amount of users, specific geographical conditions, financial investments, maintenance requirement and costs of solutions must be undertaken.

Minimum strategies regarding accessibility should be ensured in any case: reasonable slope of ramps to enable mobility of unassisted wheelchair users instead of stairs or lifts, even if it means longer routes; installation of handrails wherever they might be useful, facilitate access to community buildings, minimum width of paths, barrier free pathways with street furniture design and placement following Universal Design standards and basic signalling. In social housing programmes, look for solutions with lower buildings instead of high-rise buildings that require deployment of elevators.⁸⁸ Regarding housing, minimum dimensions for bathrooms and kitchens allowing a wheelchair to manoeuvre, and installation of grab bars should be ensured.

⁸⁸ It is key to check national regulations for limits of the number of floors in buildings without mandatory use of elevator.



Further Reading/References

CRPD Committee's General Comment No. 2 on accessibility (2014). Available at: <http://daccess-dds.ny.un.org/doc/UNDOC/GEN/G14/033/13/PDF/G1403313.pdf?OpenElement>

Eduardo Alvarez, V. C. (2007), *Operational Guidelines on Accessibility in Urban Development Projects With Universal Design Principles*, Inter-American Development Bank.

Hannula, E.-L. (2012). *Going Green , A Handbook of Sustainable Housing Practices in Developing Countries* . Nairobi: UN-HABITAT.

Ivo Imparato, J. R. (2003), *Slum upgrading and participation: lessons from Latin America* . The International Bank for Reconstruction and Development/ The World Bank: Washington, DC.

Jack Nasar, J. E.-C. (2007), *Universal Design and Visitability - From Accessibility to Zoning*. (J. E.-C. Jack Nasar, Ed.). Ohio State University: Columbus, Ohio.

Oleg Golubchikov, A. B. (2012), *Sustainable Housing for Sustainable Cities, A Policy Framework for Developing Countries*. Nairobi: UN-Habitat.

Office of the United Nations High Commissioner for Human Rights OHCHR, (2006). *Frequently Asked Questions on a Human Rights-Based Approach to Development Cooperation*. OHCHR: New York and Geneva.

United Nations, Department of Economic and Social Affairs (UNDESA) Division for Social Policy and Development, (2004), *Accessibility for the Disabled - A Design Manual for a Barrier Free Environment*, available at: <http://www.un.org/esa/socdev/enable/designmi/index.html>

Wolfgang F. E. Preiser, K. H. (Ed.), (2010), *Universal Design Handbook* (2nd ed.). McGraw-Hill.

World Health Organization and World Bank. (2011). *World Report on Disability*. WHO Press: Malta.

Bibliography

ABNT (2004). *NBR9050 Accessibility to buildings, equipment and the urban environment*, ABNT: Rio de Janeiro.

Centre on Housing Rights and Evictions COHRE (2007). *The Pinheiro Principles. United Nations Principles on Housing and Property Restitution for Refugees and Displaced Persons*, COHRE: Geneva.

Eduardo Alvarez, V. C. (2007). *Operational Guidelines on Accessibility in Urban Development Projects With Universal Design Principles*, Inter-American Development Bank.

United Nations Economic and Social Commission for Western Asia ESCWA (1999). *International Seminar on Environmental Accessibility; planning and design of accessible urban development in developing countries*, Beirut, available at: <http://www.un.org/esa/socdev/enable/disisea.htm> [accessed 15 December 2013].

Centre on Housing Rights and Evictions (COHRE) (2007). *Handbook on Housing and Property Restitution for Refugees and Displaced Persons*. OCHA/IDD, UN HABITAT, UNHCR, FAO, OHCHR, Norwegian Refugee Council (NRC), NRC Internal Displacement Monitoring Centre (IDMC).

Fernanda Magalhães, F. d. (Ed.) (2012). *Slum upgrading: Lessons learned from Brazil*. Inter-American Development Bank: Washington, D.C.

Fillipi, F. d. (2009). *Slum(e)scape: Not baling out but taking on the challenge*, available at: www.cluster.eu: <http://www.cluster.eu/slumescape-not-baling-out-but-taking-on-the-challengeslumescape-quando-la-soluzione-non-e-la-fuga-ma-una-sfida> [accessed 23 March 2014].

Fleck, J. (2006). *Designing An Accessible City: Guidelines for an accessible built environment for all in the City of London*. City of London: London.

Hannula, E.-L. (2012). *Going Green: A Handbook of Sustainable Housing Practices in Developing Countries*. Nairobi: UN-Habitat.

Help Age International (2004). *Ageing and Disability*. Ageways (64).

International Federation of Red Cross and Red Crescent Societies, (2010). *Owner-Driver Housing Reconstruction guidelines*. International Federation of Red Cross and Red Crescent Societies: Geneva.

International Organization for Standardization ISO, (2008). *ISO 15392:2008(E) -Sustainability in building construction.General principles*, Geneva: ISO.

International Organization for Standardization, (2011). *ISO/FDIS 21542:2011(E) Building construction. Accessibility and usability of the built environment*. Geneva: ISO.

International Organization for Standardization, (2014). *ISO/TS 12720:2014 Sustainability in buildings and civil engineering works. Guidance on the application of the general principles in ISO 15392*. Geneva: ISO

Ivo Imparato, J. R, (2003). *Slum upgrading and participation: lessons from Latin America*. The International Bank for Reconstruction and Development/ The World Bank: Washington, DC.

Jack Nasar, J. E.-C, (2007). *Universal Design and Visitability - From Accessibility to Zoning*. (J. E.-C. Jack Nasar, Ed.). Ohio State University: Columbus, Ohio.

Oleg Golubchikov, A. B, (2012). *Sustainable Housing for Sustainable Cities, A Policy Framework for Developing Countries*. Nairobi: UN-Habitat.

Office of the United Nations High Commissioner for Human Rights (2006). *Frequently Asked Questions on a Human Rights-Based Approach to Development Cooperation*. New York and Geneva.

Office of the United Nations High Commissioner for Human Rights (1991). *CESCR General Comment No. 4: The Right to Adequate Housing (Art. 11 (1) of the Covenant)*.

Office of the United Nations High Commissioner for Human Rights OHCHR/UN-Habitat (2009). *Human Right Fact Sheet "The Right to Adequate Housing"*. Geneva: OHCHR/UN-Habitat.

Portsmouth City Council (2006). *Design guide for wheelchair accessible housing*. Directorate of Health, Housing & Social Care. Portsmouth City Council: Portsmouth.

SH, SDPcD, CDHU, (2010). *Diretrizes do Desenho Universal na Habitação de Interesse Social no Estado de São Paulo*. CDHU: Sao Paulo.

South-North Center for Dialogue & Development, for the Office of the UN Special Rapporteur on Disabilities, (2006). *Global Survey on Government Implementation of the Standard Rules—Results Analysis October 2006*, Amman.

Stakes for the United Nations, (2003). *Disability Dimension in Development Action. Manual on Inclusive Planning*, (R. Wiman, Ed.). Stakes for the United Nations.

The Global Initiative for Economic, Social and Cultural Rights (2014). *A Rights-Based Approach to Participation*.

The Sphere Project (2011). *The Sphere Handbook-Humanitarian Charter and Minimum Standards in Humanitarian Response*. Practical Action: Hampshire.

United Nations (1948). *Universal Declaration of Human Rights*.

United Nations General Assembly (2006). *Basic Principles and Guidelines on Development-Based Evictions and Displacement. Annex 1 of the report of the Special Rapporteur on adequate housing as a component of the right to an adequate standard of living*.

United Nations General Assembly, Convention on the Rights of Persons with Disabilities, 13 December 2006, and A/RES/61/106, Annex I, available at: <http://www.refworld.org/docid/4680cd212.html> [accessed 26 January 2014]

United Nations General Assembly, Realizing the Millennium Development Goals and other internationally agreed development goals for persons with disabilities towards 2015 and beyond : resolution I adopted by the General Assembly, 13 February 2013, A/RES/67/140, available at: <http://www.refworld.org/docid/514195852.html> [accessed 15 February 2014]

United Nations General Assembly. (2013). *Report of the Special Rapporteur on adequate housing as a component of the right to an adequate standard of living, and on the right to non-discrimination in this context*.

United Nations General Assembly, Standard rules on the equalization of opportunities for persons with disabilities: resolution I adopted by the General Assembly, 20 December 1993, A/RES/48/96, available at: <http://www.refworld.org/docid/3b00f2e80.html> [accessed 25 January 2014].

United Nations General Assembly, The future we want: resolution I adopted by the General Assembly, 27 July 2012, A/RES/66/288, available at: <http://sustainabledevelopment.un.org/futurewewant.html> [accessed 25 January 2014].

UN-Habitat (2011). *Housing the Poor in African Cities, Quick Guide 2*. UN-Habitat: Nairobi.



UN-Habitat (2011). *Sustainable Building Practices for Low Cost Housing: Implications for Climate Change Mitigation and Adaptation in Developing Countries. Scoping paper.* Shelter Initiative for Climate Change Mitigation and Adaption (SICCMA).

United Nations, Department of Economic and Social Affairs (UNDESA) Division for Social Policy and Development (2004). *Accessibility for the Disabled - A Design Manual for a Barrier Free Environment*, available at: <http://www.un.org/esa/socdev/enable/designm/index.html>

Vasconcellos, B. C. (2011). *A Construção De Um Método Para Avaliação Do Ambiente Construído.* Niteroi.

Wolfgang, F. E., Preiser, K. H. (Ed.) (2010). *Universal Design Handbook (2nd ed.).* McGraw-Hill.

World Health Organization (WHO) (2002). *Towards a Common Language for Functioning, Disability and Health*, International Classification of Functioning, Disability and Health (ICF). WHO: Geneva.

World Health Organization and World Bank. (2011). *World Report on Disability.* WHO Press: Malta.

Annex 1: Checklists

The two checklists⁸⁹ presented in this chapter were developed to work as a supporting tool when planning and designing for increased accessibility in the contexts of slum upgrading, reconstruction and social and affordable housing programmes. They are complementary to Chapter 4: Technical Guidelines to Support Accessible Affordable Housing and should be applied together with the technical guidelines. The checklists should be used with discernment according to local needs and conditions.

Checklist accessible routes

The checklist on accessible routes complements the subchapters 4.1.5 Routes and 4.3 Accessible Routes, from the handbook's main text.

Street furniture and obstruction

Ensure that a vision impaired person with a cane can detect all obstacles and protruding objects en route:

- Remove protruding parts of objects in the path.
- Place tactile markings in an area extending at least 0.60 m beyond the projection area of the obstruction, or build a small raised platform (0.10 m) around obstacles.
- Fix overhang obstructions at the minimum height of 1.95 m, or alternatively, place an object that can be easily recognized with a cane, under the obstruction.

Ensure that partially sighted people (without a cane) can identify obstacles en route:

- Use contrasting colours to mark obstacles at eye level (make use of strips at least 0.30 m long).
- Place street furniture (public telephones, mailboxes, streetlights and other poles, seating facilities, etc.) in order not to block the flow of pedestrians.
- Place tactile markings in an area extending at least 0.60 m beyond the projection of the furniture.
- Provide benches and public seats at regular intervals, ideally every 100-200m.
- Provide adjoining space of at least 1.20m for wheelchair next to the seating facilities.
- Ensure seats are 0.45-0.50m high.
- Ensure the tops of tables are 0.75-0.90m high, with free knee spaces (0.70m high x 0.85m wide x 0.60m deep).
- Install at least one public telephone, accessible to a wheelchair user, adjusting booths dimensions when needed.
- Install volume controls and induction loops in at least one public telephone.
- Install push buttons with raised numerals in the telephones, to allow identification by touch.

⁸⁹ Adapted from Vasconcellos, B. C. (2011), and United Nations, Department of Economic and Social Affairs (UNDESA) Division for Social Policy and Development, (2004).

Signage:

- Make sure accessible spaces and facilities are identified by the international symbol of accessibility.
- Install directional signs indicating the location of accessible facilities.
- Place relevant information (maps, panels and wall-mounted signs) at 0.90 m - 1.80 m height.
- Ensure signs are clear, with distinguishable colours, simple and easy to read. Use matte surfaces to avoid glare.
- Provide additional text in embossed letters or in Braille⁹⁰ to existing ordinary texts and signalling.
- Ensure lettering size is proportional to the reading distance.

Pathway:

- Ensure the pathway is at least 0.90m wide.
- Make sure obstacles, including sewers, are placed outside the pathway.
- Provide a pathway that is free of steps and stairs. If not possible, build a ramp or provide an alternative route.
- Guarantee the path is easily perceptible: make use of natural guide lines, guide strips, tactile marking area at changes in the path direction (0.90m x 0.90m) and tactile marking to indicate obstacles and ramps.

- Provide a non-slip, smooth and level surface, with different colour and texture than the adjacent surfaces.
- Ensure that drains and grating, when in the pathway, are levelled with its surface; and that openings in gratings are not wider than 13mm.
- Protect edges in raised pathways.
- Install physical barriers between the pathway and landscape features such as gardens, planting areas, pools, etc.
- Choose vegetation that will not obstruct the pathway, damage its surface or harm any person (e.g. when roots or foliage grow).

Curb ramps:

- Install curb ramps or slope narrow pavements whenever there is a difference in level between the road surface and the pathway at pedestrian crossings, drop-off zones, accessible parking spaces and building entrances.
- Install curb ramps in each corner of each street intersection; make sure that there is another curb ramp on the other side the street.
- Apply a coloured texture to the surface of the curb ramp.
- Construct guidelines in the pathways to direct pedestrians to the curb ramps.
- Make sure the maximum slope of a curb ramp is 1:12-1:10. Very sloped ramps are unsafe and impossible to be used by a mobility-impaired person alone.

⁹⁰ Braille is a system of touch reading for the blind people, which employ embossed dots evenly arranged in quadrangular letter spaces or cells. Definition by: English Braille American Edition 1994. Available at <http://www.brl.org/ebae/index.html> (accessed 25/05/2014)



Pedestrian crossings:

- Ensure the road surface is even and slip-resistant at pedestrian crossings.
- Mark the pedestrian crossing area on the road surface with coloured stripes to facilitate identification.
- Install traffic lights with audible and visual signals.
- Adjust the minimum time interval for crossing adapted to a slow person.
- Adjust the height of push buttons to a maximum of 1.20 m.
- Provide a street-level pathway of at least 1.50 m wide through traffic islands.

Parking:

- Ensure accessible parking facilities, within 50.00 m of accessible building entrances. Alternatively, provide a drop-off zone near it.
- Guarantee enough number of accessible, wide enough parking spaces, according to local regulation.
- Mark accessible parking spaces with appropriate signage (international symbol of accessibility) to avoid misuse.

Checklist housing units

The checklist on housing units complements the subchapters 4.5 Design recommendations: Housing Units, from the handbook's main text.

Entrances and halls:

- Make sure the main entrance of the building/house is accessible. Inside the building, locate the elevators close to the entrance.
- Clear the approach to the main entrance of stairs and steps, build a ramp if need be.
- Identify the entrance door with a contrasting colour. In multi-story buildings add the international symbol of accessibility.
- Ensure the area subsequent to the accessible entrance is wide enough, level and non-slippery.
- Consider a non-heavy entrance door or with an easy to open mechanism.
- Guarantee a clear entrance door width that is at least 0.90 m.
- Ensure enough space for a wheelchair manoeuvre between two sets of doors. If needed, change the swing direction of the door.



Doors:

- Make use of light-weighted doors to enable operation by a mobility-impaired person.
- Ensure enough space at the latch side of the door.
- Mark all glazed doors with a coloured band at eye level.
- Guarantee clear interior doors widths at least 0.80 m.
- Use lever-type handles, as they are easier to operate.
- Adjust handles, locks and pulls to the maximum the height of 1.20 m - 1.40 m.
- Ensure that doormats, if used, are fixed and levelled with the floor.
- Ensure that doorsteps are bevelled and no more than 20mm high.

Corridors:

- For low traffic corridors, guarantee a minimum clear width of 0.90m.
- For public corridors, guarantee a minimum clear width to 1.50m. Alternatively, locate passing areas at frequent intervals.
- Ensure corridor width allow manoeuvring through doors located along its length. If needed, change the direction of the door swings.
- Install lifts or build ramps to bridge differences in level.

Ramps:

- Build a complementary ramped route next to stairs or steps, sloped maximum 1:20.
- Build resting areas with length of 1.20m, at every change of direction and at the top and bottom of the ramp. Use coloured tactile marking strips at least 0.60 m wide to clearly identify the markings.
- Use railings for protection in ramps with more than 0.45m height.
- Ensure ramp width of at least 0.90m.
- Ensure surfaces are non-slip and clear of obstructions.

Elevators:

- Make sure that an accessible path leads to an elevator.
- Guarantee that the minimum internal dimensions of an elevator cab is 1.10 m x 1.40 m and its clear door opening is 0.90 m.
- Provide handrails, mounted at a height of 0.80 m - 0.85 m on three sides of the cab.
- Adjust tolerance for stop precision to 20 mm.
- Ensure that the control panel is placed at a height of 0.90 m - 1.20 m, and control buttons are large with tactile or Braille numerals next to buttons.
- Ensure lobby call buttons are placed at a height of 0.90 m - 1.20 m.
- Provide with audible and visual warning signals such as bells, flashing lights, etc.) indicating arrival at a floor.

- Make use of non-skid finishing material in the elevator cab.
- Use a contrasting colour in elevator's doorframe to make its identification easier.
- Adjust the communication system (emergency intercom) to be usable without voice communication. Add simple tactile/Braille instructions.
- Adjust the door opening/closing interval to facilitate slow entry and exit.
- Place tactile signs at 1.40 m from the floor to identify the floor number at the elevator's door jam.

Lifts:

- Ensure the lift can be used without assistance: post simple instructions for use at each stopping level and provide a call button.
- For vertical lifts, the maximum level change is 2.50 m. If more, an elevator is needed.
- Place the lift within an enclosed structure for level changes of at least 1.20 m
- Check the minimum width of the stairs is 0.90 m before installing inclined movement platform lifts.
- Guarantee lift size of 0.90 m x 1.20 m.
- Install controls at a maximum height of exceeding 1.20 m.

Stairs:

- For multi-story buildings, ensure stairs have a minimum width of 0.90 m.
- Provide intermediate resting areas with at least 1.20 m length when the stairs cover a difference in level of more than 2.50 m.
- Provide landing areas at the top and at the bottom of the stairs with at least 1.20 m length. Use coloured tactile marking strips at least 0.60 m wide to clearly mark landing areas.
- Make sure treads have a non-slip surface.
- Identify emergency stairs with signage.

Railings and handrails:

- Install safety guards or railings and raised platforms that are more than 0.40 m high around dangerous zones. .
- Ensure that handrails are easy to grip and installed at 0.85 m - 0.90 m height.
- Make sure fixtures are secure enough and handrails well attached.
- Ensure that handrails are 0.30 m - 0.45 m horizontally extended at the top and bottom of ramps and staircases.
- Ensure that handrails are continuous throughout the full length of ramps and stairs, including resting and landing areas.
- Make use of railings when low windows are placed at resting and landing areas.

- Guarantee enough space between the handrail and the wall: 40 mm for smooth walls and 60 mm for rough textured walls.
- Make use of contrasting colours to facilitate identification of handrails.

Restrooms:

- Guarantee enough space to manoeuvre a wheelchair inside a rest room.
- Make sure that at least one shower or bathtub is accessible in a house. Alternatively, use the tiled floor of the rest room as a shower space.
- Ensure that toilets fixtures are installed at a height of 0.45-0.50m.
- Guarantee the walls on which grab bars are installed are reinforced and grab bars can withstand loads.
- Install a wall-mounted grab bar at the closest adjacent wall at a height of 0.45-0.50. Alternatively, make use of floor-mounted bars.
- Install the washbasin at a height of 0.80 m - 0.85 m and adjust fixtures.
- Make use of a secure shower seat, with 0.45-0.50m height.
- Guarantee the floor of the shower or bathtub is does not slip. Make use of slip-resistant rubber mats if needed.
- Build bevelled thresholds of 13mm maximum above the finished floor of the shower tub.
- Install grab bars with a diameter of 30-40mm in toilets, bathtubs and showers at a height of 0.85-0.95m. The grab bars should be non-slippery.
- Make use of single lever or push button taps. They are easy to grip and can be operated with only one hand.
- Use hoses for showers with a length of at least 1.50m.
- Protect hot water pipes, covering or insulating them.
- Place mirrors at a height of 1.00m (bottom of the mirror).
- Install an “alarm system” in the restroom: push buttons, bells, etc. Make sure they are reachable.
- Place flushing devices, toilet paper and dispenser in a reachable zone, from 0.50-1.20m from the floor.
- Make sure the flushing device is easy to operate.
- Make sure the floor is well drained, waterproof and non-slippery.
- Ensure that a clear door opening is at least 0.75m wide. Alternatively, remove doors if privacy is not diminished.
- Ensure doors can be released from outside in emergency situations if locked from inside.



HS/058/14E
ISBN(Volume): 978-92-1-132635-2

UN **HABITAT**

United Nations Human Settlements Programme
P.O. Box 30030, Nairobi 00100, KENYA

Telephone: +254-20-7623120, Fax: +254-20-7624266/7

Email: infohabitat@unhabitat.org

www.unhabitat.org