



THANE MUNICIPAL CORPORATION, THANE.

PUBLIC WORKS DEPARTMENT

(2016-2017)



Tender Document for....

Name of Work : Improvement of Kolshet road (From kapurbavdi naka to Airforce station) as Model Road by Renovation and Beautification of Existing Road followed by maintenance for 3 years.

THANE MUNICIPAL CORPORATION
PUBLIC WORKS DEPARTMENT

NAME OF WORK :

Improvement of Kolshet road (From kapurbavdi naka to Airforce station) as Model Road by Renovation and Beautification of Existing Road followed by maintenance for 3 years.

PRICE : Rs26,250/- (Rs Twenty six thousand two hundred fifty only) per tender book.

TO BE RECEIVED ON : On dt. 27.05.2016 upto 16.00 hrs. by E- tendering on web site
www.thanecity.gov.in & <http://mahatenders.gov.in>

TO BE OPENED ON : Envelop no 1 will opened on dt 01.06.2016. upto 16.30 hrs, if possible and Envelop no 2 will opened only after finalization of eligible tenderer and will be communicated.

Signature of Contractor

No. of Corrections

City Engineer
TMC, Thane

INDEX

Name of Work: Improvement of Kolshet road (From kapurbavdi naka to Airforce station) as Model Road by Renovation and Beautification of Existing Road followed by maintenance for 3 years.

Chapter No.	Brief Description of contents	Page No.	
		From	To
I.	Notice Inviting Tender	3	7
II.	Detailed Tender Notice	8	25
III.	General Conditions of Contract and Additional Conditions of Contract	26	68
IV.	Special Conditions of Contract	69	86
V.	General Description of work	87	93
VI.	Formats	94	101
VII.	Declaration of Contractor	102	103
VIII.	Agreement B-1 Tender Form	104	133
IX.	Price Variation Clause	134	142
X.	Schedule 'A'	143	143
XI.	Schedule 'B'	144	170
XII.	Drawings	171	183

City Engineer
Thane Municipal Corporation, Thane

Signature of Contractor

No. of Corrections

City Engineer
TMC, Thane

Chapter – I

Notice Inviting Tender

Tender No.	TMC/PRO/PWD-M/194/2016-17 dt.30.04.2016
Organization Name	Thane Municipal Corporation

Signature of Contractor

No. of Corrections

City Engineer
TMC, Thane

Department Name	Public Work Department	
Scope of Work	Improvement of Kolshet road (From kapurbavdi naka to Airforce station) as Model Road by Renovation and Beautification of Existing Road followed by maintenance for 3 years.	
Tender Notice	On line tender for the Above work of Thane Municipal Corporation are invited by City Engineer, Thane Municipal Corporation, Thane	
Tender Type	Open	
Bidder Nationality	National competitive Bidder (NCB)	
Type of Contract	Works	
Bidding Currency	Single	
Joint Venture	Allowed	
Schedule of E-Tender	Site Visit	
	Pre-bid meeting	18/05/2016 at 11.30 hrs. in the office of City Engineer, 3rd floor, Thane Municipal Corporation, Thane, Dr. Almeda Road, Panchpakhadi, Thane (w)
	Document downloading end date and time	27/ 05/2016 upto 16.00 hrs.
	Last date & time of online Bid submission	27/ 05/2016 upto 16.00 hrs.
	Online submission of EMD and Supporting documents	27 / 05 /2016 upto 16.00 hrs.
	Opening of Bid (Online) if possible	01 / 06 /2016 at 16.30 hrs. If possible.
	Bid validity period	180 Days from the date of opening
Payment Details	Document Fee	Rs. 26,250/-
	EMD	Rs. 14,33,110/-
	Estimated Value	Rs.14,33,11,000/-
Eligibility Criteria	As Per Tender Documents	
General Terms & Conditions	As Per Tender Documents	
Other Details	As Per Tender Documents	
Information for online participation	<ol style="list-style-type: none"> 1. Internet site address for e-tendering activities will be www.thanecity.gov.in and www.mahatenders.gov.in 2. Tenderers who wish to participate in online tender must register on the website http://www.mahatenders.gov.in/nic/app. Tenderers whose registration is valid, may please ignore this step. At the time of enrollment, information required for enrolment should be filled. After enrollment the tenderer will get his user name and password to his email id. 3. Tenderers who wish to participate in this tender need to procure Digital Certificate as per Information Technology Act-2000 using that they can digitally sign their electronic bids. Tenderers who already have a valid Digital Certificate need not to procure the same. A digital signature is required for purchasing and submission 	

Signature of Contractor

No. of Corrections

City Engineer
TMC, Thane

	<p>of tender.</p> <p>4. In case tenderers need any clarification regarding online participation, they can contact on help line no. 1800 3070 2232</p> <p>5. Tenderers who wish to participate need to fill data in predefined forms only.</p> <p>6. Bidder should upload scan copies of reference documents in support of their eligibility of the bid.</p> <p>7. Bidders can also submit EMD & Reference Documents in hard copy if such instructions are given by tendering authority</p>
--	--

General Guidelines for online submission.

- ▶ E-tendering process will be conducted through <http://mahatenders.gov> the e-tendering portal of Government of Maharashtra in association with Department of Information Technology, Govt. of Maharashtra, NIC & State Bank of India for e-payment. To participate in e-tendering, the intending offerers shall register themselves in the website of <http://mahatenders.gov.in>. Detail information for registration and submission of offers through e-tendering process are available in Bidders Manual kit in the website mahatenders.gov.in. There is no charge for registration for bidders.
- ▶ Tender form and relevant documents are not to be sold /issued manually from offices.
- ▶ The date and time for online submission of envelopes shall be strictly followed in all cases. The bidder should ensure that their tender is submitted online before the expiry of the scheduled date and time. No delay on account of any cause will be entertained. Tender(s) not submitted online will not be entertained.
- ▶ If for any reason, any interested bidder fails to complete any online stages during the complete tender cycle, department shall not be responsible for that and any grievance regarding that shall not be entertained.
- ▶ Tender shall be submitted in two Envelopes i.e. Technical Bid in Envelope-1 & Price Bid in Envelope-2 through e-Tendering procedure only on <http://mahatenders.gov.in> portal.
- ▶ Tenders submitted without two Bid systems and by without e-Tendering (<http://mahatenders.gov.in>) procedure shall be rejected.
- ▶ The Two Bids offer must be submitted along with document(s) as per the guidelines given in tender document by e-Tendering procedure only.
- ▶ For technical bid, bidders have to make sure that there should not be any space or special character in the file name. All the technical documents should be in .pdf Or

.rar format e.g. “Registration certificate.pdf” “Registration certificate.rar” is wrong file name. The correct file name would be “registration_certificate.pdf” “registration_certificate.rar”.

- ▶ The documents uploaded in the technical bid will be scrutinized by the Evaluation Authority as per the document asked in the tendernotice and tender document. The decision of the Tender Evaluation Authority shall be final in this regard.
- ▶ Bidder, in advance, should prepare the bid documents to be submitted as indicated in the tender schedule and they should be in PDF(for technical bid) and excel file formats(Microsoft Excel 2003 and above file) for BoQ or Price Bid. In case of technical bid, if there is more than one document, they can be clubbed together. i. e. for each cover of online envelop only single file need to be uploaded. For e.g. to upload document having multiple pages, bidder has to scan them as single document.
- ▶ For BOQ, do not modify the BOQ predefined name or sheet name of BOQ.
- ▶ Only Green cells of BOQ are for data entry.
- ▶ Do not use cut, copy or paste while data entry into the BOQ sheet.
- ▶ Any violation on the BOQ shall be subjected to rejection of the bid.
- ▶ Before uploading BOQ, kindly confirm that enter detail in BOQ has been saved correctly.
- ▶ EMD Payment will be accepted by the E-tendering process only once while Bidding.
- ▶ It is important to note that, the bidder has to Click on the ‘Freeze Bid Button’, to ensure that he/she completes the Bid Submission Process. Bids which are not frozen are reconsidered as Incomplete/Invalid bids and shall not be considered for evaluation purposes.
- ▶ For any queries relating to this eProcurement Portal, please call 24 x 7 Toll Free No. **1800-3070-2232.**

THANE MUNICIPAL CORPORATION
(Public Works Department)

Signature of Contractor

No. of Corrections

City Engineer
TMC, Thane

TENDER NOTICE

Thane Municipal Corporation, Thane invites 6 (six) separate tenders from experienced contractors on E-tender system for following work

- 1) Improvement of Kolshet Road (From Kapurbawdi Naka To Air Force Station) as Model Road by Renovation and Beautification of Existing Road. followed by maintenance for 3 years.
- 2) Improvement of S.M.Joshi Marg (Kharegaon Road From Sahakar School To Late.Atmaram Patil Chowk) as Model Road by Renovation and Beautification of Existing Road. followed by maintenance for 3 years.
- 3) Improvement of Br. Nath Pai Road(From Gandhi Nagar ESR To Happy Valley Junction To Manpada Junction) as Model Road by Renovation and Beautification of Existing Road. followed by maintenance for 3 years.
- 4) Improvement of Court Naka Area(Kalwa Bridge To Collector's Office, Court Naka To K-Villa Bridge, Civil Hospital To Central Post Office To Kalwa Police Station Canteen(Urjita), Court Naka To Central Jail) as Model Road by Renovation and Beautification of Existing Road. followed by maintenance for 3 years.
- 5) Improvement of Acharya Atre Marg (Kores Road) And P.L. Despande Marg (Rental Housing To Laxmi Park)as Model Road by Renovation and Beautification of Existing Road. followed by maintenance for 3 years.
- 6) Improvement of Kopri Meeth Bunder Road, (Mangla High School To Veesarjan Ghat),Late Narayan Koli Chowk To Asthavinayak Chowk as Model Road by Renovation and Beautification of Existing Road. followed by maintenance for 3 years.

Blank tender papers can be downloaded separately from the authorized website of TMC, www.thanecity.gov.in and www.mahatenders.gov.in from 03.05.2016 to 27.05.2016 upto 16.00 hrs. Online tenders shall be received upto 16.00 hrs on 27.05.2016 and will be opened on 01.06.2016 at 16.30 pm if possible in the presence of the willing tenderers or their representatives. For additional information contact on 022-25347714

Sd/-
City Engineer,
Thane Municipal Corporation, Thane.

TMC/PRO/PWD-M/194/2016-17

Dt : 30/04/2016

Signature of Contractor

No. of Corrections

City Engineer
TMC, Thane

Chapter – II

Detailed Tender Notice

Signature of Contractor

No. of Corrections

City Engineer
TMC, Thane

Chapter- II

THANE MUNICIPAL CORPORATION, THANE

DETAILED TENDER NOTICE

On line tenders are invited for Improvement of Kolshet road (From kapurbavdi naka to Airforce station) as Model Road by Renovation and Beautification of Existing Road followed by maintenance for 3 years by municipal corporation from appropriate contractors / J.V. who are registered with PWD/CPWD/CIDCO/BMC/MIDC / other with Govt./Semi govt./Public sector undertakings in appropriate class & experience criteria as given in a detail tender notice. The blank tender forms can be downloaded from www.thanecity.gov.in & <http://mahatenders.gov.in> from date 03.05.2016 to date 27.05.2016 up to 16.00 hrs. On line tender shall be received on the website www.thanemahapalika.com upto 16.00 hrs on or before date 27.05.2016 and will be opened on date 01.06.2016 @ 16.30 hrs if possible.

S.N	Name Of work	Estimated Cost Rs.	Earnest Money Rs.	Tender form cost Rs.	Class registration	Time limit
1.	Improvement of Kolshet road (From kapurbavdi naka to Airforce station) as Model Road by Renovation and Beautification of Existing Road followed by maintenance for 3 years.	14,33,11,000/-	14,33,110/-	26,250/-	Appropriate class in PWD / CPWD/ BMC/ CIDCO/ MIDC	8 (Eight) Months including Mansoon

1. Tenders hereunder are being invited in accordance with competitive bidding procedures of Thane Municipal Corporation, Thane.
2. All bidders are cautioned that tenders containing any deviation from the contractual terms and conditions specifications or other requirements are liable to be rejected as non-responsive.
3. All tenderers are urged to promptly submit a written request to the City Engineer, Thane Municipal Corporation, on matters where clarification or additional information is desired.
4. The tender document can be downloaded from the web site www.thanemahapalika.com also. The applicant has to ensure that all papers are completely downloaded.
5. If in any case, any discrepancy is observed in downloaded tender document with printed tender document, the tenderer is bound to accept all the conditions as printed in the tender document.

Signature of Contractor

No. of Corrections

City Engineer
TMC, Thane

6. Tenderer shall throughly observe all Conditions, Special Condition and Specially **“Conditions for Maintenance for 3 years.”**
7. *Contractor shall quote for all 3 parts of tender collectively. Part- A consist of Construction Works to be carried out . Part-B consist of Maintenance of road for the tenure of 3 years and Part-C consist of Collection of Money through Parking.*
Contractor/s has to quote his offer in % (percentage) rate for Part-A , Lumsum Amount for Part –B and Rebate against parking in Part-C
8. Contractor must qualify the following criteria otherwise Envelop no.2 (Price Bid) shall not be opened.
- Valid Registration Certificate in appropriate class as mentioned above.
 - Average annual turnover in last 3 years should not be less than 75% of the cost put to tender as per current rate. It shall be certified by Chartered Accountant.
 - Contractor should have completed single similar work costing 30% of the cost put to tender for work upto Rs.10 cr, and 30% of the cost put to tender or Rs.5.0 crore whichever is more for work above Rs.10 cr.as per current rate. **Similar work will be considered as any type of roads.** The tenderer should submit the experience certificate from the officer not below the rank of Executive Engineer or Equivalent.
 - Tenderer should have executed the 30% (Thirty Percent) quantities of Bituminus work by using CRMB-60 and PMB-40 covering area not less than 11172 sq.mt. of work tendered, in one year with Government/ Semi-Government /Public sector undertaking. The tenderer should submit the certificate from the officer not below the rank of Executive Engineer or Equivalent.
 - The tenderer shall have to submit MOU with registered Electrical contractor on non judicial stamp paper worth Rs 200/- having registration with Central/State/ Semi-Govt organisation and should have successfully completed at least one work of street light poles.The completion certificate should not be below the rank of Executive Engineer.
 - Civil contractor will be treated as main contractor and he should have JV with Electrical contractor.In case of Joint venture, the contractor shall clearly define the role/ share in terms of percentage. Share of cost of higher contractor should not less than 50%. Percentage cost of work of lower contractor should not be exceeding his own eligibility limit. Eligibility limit will be calculated as per the estimated cost and share of lower contractor.JV or MOU deed should be irrevocable till the completion of work & for the Subsequently Three Years of Maintainance period for which they have combined and till all the liabilities.

In case of JV and MOU, all JV and MOU combined partners cannot perform JV or MOU with any other contractor for same work.Any partner of JV/MOU is only allowed to participate with another partner for other works only if other partners are not willing to participate.

It is necessary to enclose the registration certificate of joint venture firm with the Registrar of the Firm or the receipt of payment made to Registrar of the Firm on account of fees towards joint venture firm. In case of J.V. tenderer who had submitted receipts of J.V. at the time of submission shall furnish the registration certificates of joint venture from the Registrar of the Partnership Firm Maharashtra State before issuing the work order.

1) Registrar of firms, Maharashtra State, Mumbai.

New Administrative Building, 6th Floor, Near Chetna Collage, Govt. Colony,
Bandra(E), Mumbai 400051.
Ph No. 022-26551149, 022-26551944.

2) Assistant Registrar of firms, Pune.

Survey No.47/30, Sarswati parvati Bhavan, 2nd floor, Behind Lokesh Hotel,
Arnyshwar Corner, Pune Satara Road, Pune 411009
Ph. No. 95250-24221808

3) Assistant Registrar of firms, Nagpur.

118, old Sachivalay Building, Civil Lines, Nagpur 440001.
Ph.No.95712-2530897

4) Assistant Registrar of firms, Aurangabad.

Gadiya Building, House No. 5/1/100, Near Divisional library Office,
Eknathnagar Road, Usmanpura, Aurangabad 431005.
Ph.no.952402336798

In case of J.V. tenderer outside the Maharashtra state, Joint Venture registration certificate from the office of Registrar of firm of other states will be considered.

g) The contractor should submit bid capacity while submitting the tender in the following formula,

$$\text{Bid Capacity} = (A \times N \times 2) - B$$

Where,

A - Max. annual turnover during last three years.

N - Time period of work

B - Works in hand during time period of the work required.

Following enhancement factors will be used for the costs of the works executed and the financial figures to a common has for the current value of works complete in India

Financial Year	Multiplying Factor
2015- 2016	1.10
2014 - 2015	1.21
2013- 2014	1.331

Signature of Contractor

No. of Corrections

City Engineer
TMC, Thane

- h) The tenderer should possess his own Batch Type HotMix plant situated within 30 Km from the work site. The Plant should not be more than 5 years old. If the plant proposed to be used is more than 5 years old, in that case tenderer shall have to submit the present valuation certificate by the Government certified valuer, stating that the plant is in good working condition & can produce the required quantity of DBM & AC given in schedule B and possess Sensor Paver and minimum 2 Vibratory Rollers.
- i) Detail tender notice will be available in the office of City Engineer, Thane Municipal Corporation, Thane. The tender document can also be downloaded from the website of TMC, www.thanecity.gov.in/ and www.mahatender.gov.in. The applicant has to ensure that all pages are completely downloaded.
- j) If in any case, any discrepancy is observed in downloaded tender document with printed tender document, the tenderer is bound to accept printed tender document.
- k) If any queries regarding tender, contact in the office of City Engineer TMC, Thane.
- l) Applicant will need to produce originals of their all-supporting enclosure for verification by TMC if required. Failure to comply with this requirement may result in the disqualification of the applicant without any reason.
- m) The right to reject any or all tenders without assigning any reason thereof is reserved by The Commissioner, Thane Municipal Corporation, Thane.
- n) Pre bid meeting will held in the office of City Engineer 3rd floor, Panchpakhadi, thane Municipal Corporation (TMC) on dt. 18.05.2016 time 11.30 am.
- o) For other details regarding online tendering, contacthelp line no. 1800 3070 2232.

City Engineer,
Thane Municipal Corporation, Thane

1. DESCRIPTION OF PROJECT

Improvement of Kolshet road (From kapurbavdi naka to Airforce station) as Model Road by Renovation and Beautification of Existing Road followed by maintenance for 3 years.

2. ELIGIBILITY AND QUALIFICATION REQUIREMENTS

The eligibility and qualification requirements are mentioned in the Detailed Tender Notice above.

3. PURCHASE OF DOCUMENTS

Blank tender document will be available on web site www.thanecity.gov.in & <http://mahatenders.gov.in> from date 03.05.2016 to date 27.05.2016 up to 16.00 hrs. The tenders form fee of Rs. 26,250/- (In word Rs Twenty six thousand two hundred fifty only) is to be submitted.

4. PERIOD OF COMPLETION

The period of completion shall be 8 (Eight) calendar months including monsoon from the date of order to proceed with the work.

5. EARNEST MONEY and TENDER FORM FEE

- i) The amount of Earnest Money Rs. 14,33,110 /- (Rs Fourteen lakh thirty three thousand one hundred ten only) and tender form fee including VAT Rs.26,250/- shall be payable through Net-Banking only. Earnest money deposit Exemption certificate issued by state government organization shall not be accepted.
- ii) Earnest Money in the form of Cheque or any other form than prescribed above will not be accepted. Tenders of those contractors who do not deposit Earnest Money in one of the above accepted form, shall be summarily rejected.
- iii) Tender not accompanied by an Earnest Money Deposit is liable to be rejected as non-responsive. If during the tender validity period, the tenderer withdraws his tender, the Earnest money deposit shall be forfeited and the tenderer may be disqualified from tendering for further works in the Thane Municipal Corporation, Thane.

Signature of Contractor

No. of Corrections

City Engineer
TMC, Thane

- iv) The Earnest Money Deposit will be returned to the unsuccessful tenderers, when it becomes due. The Earnest Money Deposit will be returned to the successful tenderer after he furnishes initial Security Deposit and duly enters into the contract.
- v) Within ten days from the date of receipt by him of the letter of having acceptance of his tender, the successful tenderer shall furnish the required initial Security Deposit and attend the office of the City Engineer, Thane Municipal Corporation, Dr. Almeda Road, Panchpakhadi Thane for execution of the contract document. If the successful tenderer fails to furnish Security Deposit or to execute the contract his earnest money deposit shall be forfeited and the tenderer may be disqualified from tendering for further works in the Thane Municipal Corporation, Thane.

6. LANGUAGE OF TENDER

The tenders shall be submitted in the prescribed forms in “English” language only. Language for communication may be Marathi.

7. TENDER VALIDITY PERIOD

Validity of the offer will be 180 days from the date of opening of tender documents and thereafter unless it is withdrawn by notice in writing duly address to the Tender opening authority, i.e. “The City Engineer, Thane Municipal Corporation”, Dr. Almeda Road, Panchpakhadi, Thane.

8. OPENING OF TENDERS

Tenders will be opened from website, in the presence of bidder or his representative who choose to remain present at City Engineer office at 16.30 hrs. on date 01.06.2016 if possible. The tenderer or their representative who are present shall sign the register in token of their attendance.

9. WHOM TO CONTACT

The Executive Engineer, Model road section , PWD section, 3rd floor, Mahapalika Bhavan, Chandanwadi, Panchpakhadi, Thane ,400 601 may be contacted for any further information.

10. THE TENDER ACCEPTING AUTHORITY

The acceptance of tender vests with the Competent Authority of Thane Municipal Corporation, Thane who reserves the right to reject any or all tenders without assigning any reason thereof. The award of the contract shall be at the discretion the tender Accepting Authority.

11. A) SECURITY DEPOSIT

- 1) The successful tenderer whose tender is accepted will have to pay the initial Security deposit of 2% of the contract value in the form of DD or in the form of Bank Guarantee (in the form prescribed by the Thane Municipal Corporation, Thane as per Govt Stamp Duty Act. Specimen form is enclosed in the tender Documents) for the entire period of contract, **including defect liability period and maintenance period**, of any Schedule/ Nationalised Bank within prescribed time and complete the contract agreement failing which his/their (Contractor's) Earnest Money will be forfeited to Thane Municipal Corporation, Thane. The balance Security Deposit of 3% of the contract amount will be recovered from the Running Accounts Bills at 5 % of Gross value of the bill till the recovery of full remaining amount.. All compensation or other sums payable by the Contractor under the terms or any other contracts or accounts with TMC as may be decided by the Municipal Commissioner may be deducted from his Security Deposit or - from any sums which may be due to him or may become due to him, by Government on any account and in the event of Security being reduced by reason of any such above noted deductions, the contractor shall, within ten days of receipt of notice of demand from the City Engineer make good the deficit. There shall be no liability on the Thane Municipal Corporation to pay any interest on the Security amount deposited or recovered from the contractor.

After issue of completion certificate to contractor, if contractor desires, can deposit whole Security Deposit i.e. 5% of the value of tender in the form of Bank Guarantee drawn in favour of TMC, on any Nationalized or Scheduled bank having branch in Mumbai in the enclosed format valid till defect liability period. After successfully completion of defect liability period TMC will issue maintenance certificate and contractor thereafter will have to request in writing for release of Security Deposit.

- 2) The Defect liability period for all works shall be 3 (Three) years. The defect liability period for LED fixtures installed in this work shall be 5 (Five) years. Additional 5% S.D. will be deducted for LED fixtures which will be reckoned from RA bills and will be released after DLP i.e 5 years. Contractor should submit Guarantee Bond from the manufacturer for the same.

Condition for Additional Performance Security Deposit (APSD) if the offer is lower than the estimated cost put to tender -

In case tenderer offers less than the estimated cost put to tender, tenderer should submit the rate analysis with explanation of how the work will be carryout in the quoted offer (rate) and tenderer will have to pay additional performance security deposit irrespective of general security deposit prescribed in tender, for

performance of the work. The amount of additional Security deposit shall be as follows :

i) In case the tenderer offers the rates lower than the estimated cost put to tender but not less than 10%, tenderer should have to pay additional performance security deposit of 1% of estimated cost to put to tender in the form of Demand Draft of any Nationalized or Scheduled Bank drawn in the favour of Thane Municipal Corporation.

ii) In case the tenderer offers the rates lower than 10% below the estimated cost put to tender, tenderer should have to pay additional performance security deposit of amount equal to rebate offered beyond the 10% of cost put to tender in addition to the amount of 1% amount of cost put to tender in the form of Demand Draft of any Nationalized or Scheduled Bank drawn in the favour of Thane Municipal Corporation. The amount of additional Security deposit shall be as follows :

FORMULA :

Additional Performance Security Deposit (APSD) = $1 * (X/100) * \text{cost put to tender}$

Where X= Percentage rebate quoted on the cost put to tender by the tenderer

For Examples :

If the tenderer desires to quote 14.15% below (fourteen point fifteen percent below/less) on cost put to tender of Rs 3,50,00,000/- then the additional performance security deposit shall be worked out as under :-

$$= \{[(14.15-10)/100]*3,50,00,000/-\} + (1/100)*3,50,00,000/-$$

$$= \text{Rs } 18,02,500/-$$

iii) Manner of submission of the Additional Performance Security Deposit –

- a) Demand Draft should have MICR and IFSC code and valid for minimum 3 months from the date of submission of tender.
- b) Demand Draft should be drawn in favour of Thane Municipal Corporation.
- c) Scanned copy of the Demand Draft should be uploaded while submitting the bid.
- d) Original Demand Draft should be submitted in sealed envelope marked with name of work on top right corner and tender notice number / tender ID on right left corner within 5 working days from the prescribed date of submission in the office of City Engineer.

iv) Manner of refund of the Additional Performance Security Deposit –

- a) In case of bidders those who are not qualified after scrutiny of technical bid, Demand Draft will be refunded within 7 days from the date of opening of tender (technical bid) subject to written request for refund of ASPD.
- b) After opening of financial bid, Demand Draft of the tenderers other than first two lowest, will be refunded within 7 days from the date of opening of tender (financial bid) subject to written request for refund of ASPD.
- c) After issue of work order to the successful tenderer, Demand Draft of the second lowest tenderer, will be refunded within 7 days from the date of work order subject to written request for refund of ASPD.
- d) Additional Performance Security Deposit will be refunded after 3 months from the date of completion of work as certified by the engineer, in case of successful tenderer subject to written request for refund of ASPD.

B) PERFORMANCE GUARANTEE FOR MAINTENANCE WORK.

The successful tenderer whose tender is accepted will have to pay the **Additional Security deposit @ 10%** of accepted offer of bidder in the Form of Bank Guarantee of any Schedule/ Nationalised Bank as **Performance Guarantee** for the period of 3 (three) years of maintenance before issuing work order. If Contractor fails to execute maintenance work, then, it will be liberty to corporation to carry out such maintenance work through other contractor by giving 72 hours notice. All compensation or other sums payable by the Contractor under maintenance work as may be decided by the Municipal Commissioner may be deducted from his Additional Security Deposit taken for Performance Guarantee. This Security Deposit will be released after completion of Maintenance Period.

12. TENDER DOCUMENTS

12.1 Contents of Tender Documents

A set of tender documents issued for the purpose of tendering shall comprise of

- Notice Inviting Tender
- Detailed Tender Notice.
- General Conditions & Additional Conditions of Contract.
- Special conditions of contract.
- Description of work
- Technical Specifications
- Form of Bank Guarantee in lieu of Bid Security.
- Declaration of Contractor.
- Agreement Form 'B- 1'.
- Price Variation Clause

Schedule 'A' & conditions governing Supply of materials as per Schedule 'A' of Tender.

Schedule 'B' & Item wise Specifications & Drawings.

Common Set of Deviation if issued after pre bid conference shall also form a part of tender documents.

- 12.2 The tenderer shall have to quote for all works mentioned in Price Bid. Incomplete bidding will be treated as non responsive and rejected outright. The tenderer is deemed to have examined carefully all instructions, conditions, forms, terms, technical specifications, Schedule 'B' and Drawings in the tender documents. Failure to comply with the requirements of tender submission shall be at the tenderer's own risk. Tenders who are not substantially responsive to the requirement of the tender documents are liable to be summarily rejected.
- 12.3 The tenderer shall submit only an unconditional offer which complies fully with the requirements of the tender documents.
- 12.4 All tenderers are cautioned that no alternative or conditional offers, variations or deviations by the tenderers in respect of any item proposed by the tenderers (including advance loan for mobilization for timely completion, etc.) shall be entertained or considered further in the process of tender evaluation. Furthermore, any deviation from the conditions of tender or technical specifications or other requirements stipulated in these tender documents other than those specifically clarified/amended in the minutes of the pre-bid meeting shall be summarily rejected as non responsive.
- 12.5 The data furnished in the tender documents are only by way of general information and the department will not entertain any claims due to variation from this data or for any expenses incurred by the tenderer in this connection. The tenderer shall himself obtain all necessary information as to risk and costs and other circumstances which may affect or influence this tender. No extra charges consequent on any misunderstanding or, otherwise shall be allowed.
- 12.6 At any time prior to the deadline for submission of tenders the City Engineer, Thane Municipal Corporation, Thane, may for any reason whether at his own initiative or in response to a clarification requested by a prospective tenderer modify the tender documents by the issuance of an Addendum/corrigendum.
- 12.7 The addendum will be displayed on website, all tender has to check addendum time to time on website and will be binding upon tenderer irrespective of whether the prospective tenderers downloaded from website or not.
- 12.8 In order to afford prospective tenderers reasonable time to take the Addendum/corrigendum into account for the preparation of their tenders, the City Engineer, Thane Municipal Corporation, Thane at his discretion extend the deadline for the submission of tenders.

13. MANNER OF SUBMISSION OF TENDER AND ITS ACCOMPANIMENT

Signature of Contractor

No. of Corrections

City Engineer
TMC, Thane

13.1 The tender should be submitted as per E-tendering procedure.

ENVELOPE NO.1: (Technical Bid)

Envelope No.1 (Technical Bid) shall contain :-

13.1.1 Challan receipt of Tender form fee.

13.1.2 Earnest money deposits Rs. 14,33,110 /- (Rs Fourteen lakh thirty three thousand one hundred ten only) and tender document fees of Rs.26,250/- along with the tender should be deposited on-line as per E-tendering procedure.

Department Code – 1000, Fuction Code – 215, Budget Code - 413326

13.1.3 Scanned Documents fulfilling all conditions mentioned in tender notice.

13.1.4 Details of other works Tendered for and in hand with value of unfinished works on the date of submission of this Tender (Form-I).

13.1.5 Memorandum and article of association / Partnership deed and certified copy of Power of Attorney (if any)

13.1.6 List of machinery and plant to be used for tendered work and List of Technical personnels with contractor for execution of this work.

13.1.7 Affidavit (as per Form-V) regarding Documents/Papers submitted in Envelope-1.

ENVELOPE NO. 2 (Price Bid)

Envelope No.2 (Price Bid) shall contain :-

13.2.1 The Tenderer should quote his offer in the space provided in the Tender form both in words and figures. In addition to this, envelope shall contain Common set of deviation/conditions/stipulations issued by the Department after Pre-bid meeting. The tenderer should not quote his offer any where directly or indirectly in Envelope No.1 The tenderer shall quote for the work as per details given in the main Tender documents and also based on the detailed common set of deviations/conditions/stipulations made by the Department informed to him by a letter from the City Engineer, Thane Municipal Corporation, Thane after Prebid meeting. This Tender offer shall be unconditional.

13.2.2 The Commissioner, Thane Municipal Corporation, Thane may at his discretion extend the deadline for the submission of tenders by issuing an amendment in accordance if desires and same will be published on website and newspaper.

14. OPENING OF TENDERS

On due date and specified time following procedure will be adopted for opening of the tender.

ENVELOPE NO. 1

Signature of Contractor

No. of Corrections

City Engineer
TMC, Thane

First of all, EMD & tender fee submitted by all tenderes on line as per E-tendering procedure and other documents will be verified as per tender requirement. If various documents contained in this envelope do not meet the requirements of the department, a note will be recorded accordingly by the tender opening authority and Envelope No. 2 will not be considered for further action and same will be recorded. All the tenderer should produce original documents for verification of online submitted document as and when asked.

The tenders are liable to reject out right, if while submitting –

- 14.1.1 The tenderer proposes any alteration in the work specified in the tender or in time allowed for carrying out work or any other unacceptable condition.
- 14.1.2 The tenderer, does not sign and the signature/signatures (in case of firm each partner or power of attorney holder) is not witnessed by a respectable person in the space provided .

ENVELOPE NO. 2

As far as possible, this envelope shall be opened after verification of the documents in Envelop No. 1. After opening of Envelop No. 2 of tender , the offer quoted therein shall be read out.

15. ACCEPTANCE OF THE TENDER

Acceptance of the tender would be intimated to the Contractor telegraphically or otherwise either by the office competent to accept the tender or by City Engineer, Thane Municipal Corporation, Thane and such intimation shall be deemed to be an intimation of acceptance of tender, given by the authority competent to accept the tender.

Signature of Contractor

No. of Corrections

City Engineer
TMC, Thane

FORM-I**DETAILS OF OTHER WORKS TENDERED FOR AND IN HAND
AS ON THE DATE SUBMISSION OF THE TENDER**

Name of the Tenderer :-

Sr. No.	Name of the work	Name and address of the Organisation of whom the work was done	Place & Country	Work in hand		Anticipated date of completion	Works tendered for			Remarks
				Tendered Cost	Cost of remaining work		Estimated cost	Date when decision is expected	Stimulated date or period of completion	
1	2	3	4	5	6	7	8	9	10	11

Signature of Contractor

No. of Corrections

City Engineer
TMC, Thane

FORM-II**LIST OF MACHINERY AND CETERING FORM WORK OWNED & AVAILABLE WITH THE TENDERER WHICH WILL BE USED ON THIS WORK**Name of the Tenderer :-

Sr. No.	Name of Equipment	No. of Unit	Type & makes	Capacity	Age of Machinery	Present location with name & address of the Organisation	Whether the Machinery is Hypothecated to any division, Bank or Institution	Remarks
1	2	3	4	5	6	7	8	9

Signature of Contractor

No. of Corrections

City Engineer
TMC, Thane

FORM – III**LIST OF TECHNICAL PERSONNEL AVAILABLE WITH THE TENDERER
TO BE APPOINTED ON THIS WORK**Name of the Tenderer :-

Sr. No.	Name of Person	Designation/Post held/Status	Academic Qualification & Experience in similar works	Remarks (any other points)
1	2	3	4	5

Signature of Contractor

No. of Corrections

City Engineer
TMC, Thane

FORM -IV**BAR CHART SHOWING EXECUTION OF WORK & DEPLOYMENT OF
MANPOWER & MACHINERY FOR THIS WORK**Name of the tenderer :-

Sr. No.	Nature of work to be complete d	1st Month			----- Month			Last Month		
		Deployment of		Physical % Completi on of Work	Deployment of		Physical % Completion of Work	Deployment of		Physical % Completion of Work
		Man Power	Machine ry		Man Power	Machine ry		Man Power	Machine ry	
1	2	3	4	5	6	7	8	9	10	11
1										
2										
Total										

Signature of Contractor

No. of Corrections

City Engineer
TMC, Thane

FORM – V

**FORMAT FOR AFFIDEVIT
(on stamp paper)**

I/WeAgeyear, Residing

.....
..... by this Affidavit, I/We are giving in writing that , I/We
..... Owner/Firm

Proprietor/Partner of this Company have submitted the Tender for the work of

.....All the Papers/Documents, that
I/We have submitted in this Tenders Envelope No.01 are True, Correct and
Complete.I /We hereby assured that, I/We will produce all original document /papers
as and when asked by the corporation. If fails to produce and show such documents/
papers and If any Papers/Documents are found misleading, False and incomplete
then, I/We will be responsible and will remain responsible for the legal action taken
by the Thane Municipal Corporation.

Contractor’s signature

Signature of Contractor

No. of Corrections

City Engineer
TMC, Thane

Chapter – III

**General Conditions of Contract
And
Additional Conditions of Contract**

Signature of Contractor

No. of Corrections

City Engineer
TMC, Thane

CHAPTER-III

GENERAL CONDITIONS AND ADDITIONAL CONDITIONS

1. WORK AND SITE CONDITIONS :

General Description of Work :-

Improvement of Kolshet road (From kapurbavdi naka to Airforce station) as Model Road by Renovation and Beautification of Existing Road followed by maintenance for 3 years.

2. CONTRACTOR TO INFORM HIMSELF FULLY :

2.1 The Contractor shall be deemed to have carefully examined the work and site conditions land including labour, the general and the special conditions, the specifications, schedules, drawings and shall be deemed to have visited the site of work and to have fully informed himself regarding the local conditions and carried out his own investigations to arrive at rates quoted in the tender. In this regard he will be given necessary information to the best of knowledge of the department but without any guarantee and liability about it.

If he shall have any doubt as to the meaning of any portions of these general conditions or the special conditions or the scope of work or the specifications and drawing or any other matter concerning the contract he shall, in good time, before submitting his tender, set forth the particulars thereof and submit them to the City Engineer, Thane Municipal Corporation, Thane in writing in order that such doubts may be clarified authority before tendering.

Once a tender is submitted, the matter will be decided according to tender conditions in the absence of any such authentic pre-clarification.

2.2 Errors, Omissions and Discrepancies :

- (a) In case of errors and/or disagreement between written and scaled dimensions on the drawing or between drawing and standard specifications etc'. the following order of preference shall supply.
 - (i) Between actual scaled and written dimension or description on a drawing the latter shall be adopted.
 - (ii) Between the written or shown description of dimension in the drawing and corresponding one in the specifications, the latter shall apply.

Signature of Contractor

No. of Corrections

City Engineer
TMC, Thane

- (iii) Between the quantities shown in Schedule of quantities and those arrived at from the drawings, the latter shall be adopted, subject of course, to actual measurement at site.
- (iv) Between the written description of the item in the schedule of quantities and the detailed description in specifications of the same items, the latter shall be adopted
- (b) In case of discrepancy between percentage rate quoted in figures and words, the lowest of the two will be considered for acceptance of the tender.
- (c) In all cases of omissions and/or doubts for any items or specification, a reference shall be made to the City Engineer, Thane Municipal Corporation, Thane whose elucidation, elaboration or decision shall be considered as authentic. The Contractor shall be held responsible for any errors that may occur in the work through lack of such reference and through lack of such precaution.

2.3 Working Methods :

The work disturbing present traffic, the contractor has to provide necessary diversion, barricading etc. at his own cost till the completion of work without any claim on the department. Contractor shall submit, within the time stipulated by the City Engineer in writing the details of actual methods that would be adopted by the contractor for execution of any item as required by Engineer at each of the locations supported by necessary detailed drawings and sketches including those of the Plant and Machinery that would be used, their locations, arrangement for conveying and handling material etc. and obtain prior approval of the Engineer-in-charge well in advance of starting of such item of work. The City Engineer reserves the right to suggest modification or make complete changes in method proposed by the Contractor, whether accepted previously or not, at any stages of work, in order to obtain the desired accuracy, quality and progress of work which shall be binding on the contractor and no claim on account of such changes in method of execution will be entertained by Government so long as specifications of the item remain unaltered.

As this work involves improvement ,beautification and renovation of existing road by Civil ,Electrical,and Gardening work . Further, while executing the work of shifting of existing services/laying of new services like water supply pipe line, sewer line, MSEDCL cables, MTNL cables, OFC cables etc. may be carried out by respective agencies during the work. Contractor should coordinate with respective agencies for completion of work in stipulated period.

Signature of Contractor

No. of Corrections

City Engineer
TMC, Thane

Further, some part of this work may be executed by developers related to the property under development. Hence contractor should coordinate with the developers also.

2.4 Progress Schedule :

a) **The contractor shall furnish within 7 days on receipt of order to start the work, a progress schedule in quadruplicate** indicating the date of actual start, the monthly progress expected to be achieved and anticipated completion date of each major item of work to be done by him, also indicating dates of procurement and setting up of materials, plant and machinery. **Failing which penalty Rs. 2000/- per day will be charged.** The schedule should be such as to be practicable of achievement towards the completion of the whole work in the time limit. The progress schedule will be scrutinized and approved with/without modifications by the City Engineer. No revised schedule shall be operative without such acceptance in writing. The City Engineer further empowered to ask for more detailed schedule or schedules say week by week, for any item or items, in case of urgency of work as will be directed by him and the contractor shall supply the same as and when asked for. **The contractor will be responsible for maintaining the progress according to schedule laid down in Clause 2 of 'B-1' Tender Form.** The progress schedule shall be in the form of Bar chart /C.P.M. chart or any other form prescribed by City Engineer.

(b) **The contractor shall furnish sufficient plant and equipment and labour as may be necessary to maintain the progress schedule.** The working and shift hours restricted to two shift a day for operations to be done under the supervision shall be such as may be approved by the Engineer Night work which requires supervision shall not be permitted except when specifically allowed by the City Engineer each time, if requested by the Contractor. The Contractor shall provide necessary lighting arrangements etc . for night work, as directed by the City Engineer at his own cost. The list of plant & machinery proposed for the work if found inadequate to meet with target in that case , contractor will have to mobilized additional plant, equipment & manpower to achieve target. No extra cost will be paid for such arrangement for the reason because the contractor has himself assessed equipment to be mobilized for the work.

(c) Further the contractor shall submit the progress report of work at intervals of one months or as may be specified by the City Engineer

(d) The contractor shall maintain proforma charts, details regarding machinery, equipment, labour, materials, personnel etc. are actually employed and submit weekly report thereof or as may be specified by the City Engineer.

2.5 **Treasure Trove :**

In the event of discovery by the contractor or his employees, during the progress of the work of any treasure fossils, mineral or any other article of value or interest, the contractor shall give immediate intimation thereof to the City Engineer and forthwith handover to the City Engineer such treasure things which shall be the property of the Thane Municipal Corporation.

2.6 **Agent and Work Order Book :**

The contractor shall himself manage the work or engage authorised all time agent on the work capable of managing and guiding the work and understanding the specifications and contract conditions. A qualified and experienced graduate Engineer shall be provided by the Contractor as his agent for technical matters in case City Engineer considers this as essential for the work and so directs the contractor He will take order as will be given by the City Engineer or his representative and shall be responsible for carrying, them out. This agent shall not be changed without prior intimation to the City Engineer or his authorised representative on the work site. The Contractor shall supply to the Engineer the details of all supervisory and other staff employed by the contractor and notify changes when made and satisfy the engineer regarding, the quantity and sufficiency of the staff, thus employed.**The Engineer will have the unquestionable right to ask for changes in the quality and numbers of contractor's supervisory staff and to order removal from work of any staff member.**The Contractor shall comply with such orders and effect replacement to the satisfaction of City Engineer.**A work order book shall be maintained on site and it shall be property of Thane Municipal Corporation, Thane and the contractor shall promptly sign orders given therein by City Engineer his representative on the work and comply with them.**The compliance shall be reported by the contractor to the City Engineer in good time so that it can be checked. The blank work order book with machine numbered pages will be provided by the Thane Municipal Corporation free of charge for this purpose. The contractor will be allowed to copy out instruction given therein from time to time.

2.7 **Initial Measurement for Record :**

Where for proper measurement of the work, it is necessary to have an initial set of levels or other measurement taken, the same as recorded in the authorised field book or measurement book of Thane Municipal Corporation by the City Engineer or his authorised representative and will be signed by the contractor who will be entitled to have a true copy of the same made at his cost.Any failure on the part of the Contractor to get Such levels etc. recorded before starting the work, will render him

liable to accept the decision of the City Engineer as to the basis of taking measurements, like wise the contractor will not cover any work which will render its subsequent measurements difficult or impossible, without first getting the same jointly measured by himself and the authorised representative of the City Engineer. The record of such measurements made by the department will be signed by the contractor and he will be entitled to have true copy of the same made at his cost. Whenever there is change in strata during actual execution in respect of item of Schedule 'B' it will be the responsibility of the contractor to intimate this immediately to the Department and get the levels at the change of strata finalised before doing the further work.

2.8 Handing Over the Work :

All the work and materials, before finally taken over by department will be the entire liability of the contractor for guarding, maintaining and making good any damage of any magnitude interim payments made for such work will not alter this position. The handing over by the contractor and taking over by the City Engineer or his authorised representative will be always in writing, copies of which will be going to the City Engineer or his authorised representative and the contractor duly signed by both the parties.

2.9 Assistance in Procuring Priorities, Permits etc. :

The City Engineer on a written request by the contractor, will if in his opinion, the request is reasonable and in the interest of work and its progress, assist the contractor, in securing, the priorities for deliveries, transport permits for controlled materials etc. when such are needed. The Thane Municipal Corporation will not be responsible for the non-availability of such facilities or delay in this behalf and no claim on account of such failures or delay shall be allowed by the Thane Municipal Corporation. The contractor shall have to make his own arrangement for machinery required for the work.

2.10 Samples and Testing of Materials :

- (i) All materials to be used on the work such as cement, lime, bricks, aggregates, steel, stones, asphalt, wood, tiles bitumen etc. shall be got approved in advance from the City Engineer or his authorised representative on work and shall pass the test or analysis
- (ii) **The contractor shall establish a field laboratory at his cost for testing of construction material, compressive strength of concrete cubes, gradation & extraction test etc. for bitumenous work etc. as per specifications and the instructions of the City Engineer or his authorised representatives on work.**

Signature of Contractor

No. of Corrections

City Engineer
TMC, Thane

- (iii) **In addition the contractor shall at his risk and cost make all arrangements and/or shall provide for all such facilities as the City Engineer or his authorised representative on work may require for collecting, preparing and forwarding required number of samples for tests or for analysis to the TMC laboratory or the name of the laboratory directed by the engineer incharge and bear all charges and cost of testing.** Such samples shall also be deposited with the City Engineer or his authorised representative on work.
- (iv) The contractor shall, if and when required, submit at his cost the samples of the materials to be tested or analysed and if so directed, **shall not make use of or incorporate in the works any material to be represented by the samples until the required test or analysis have been made and the materials finally accepted by the Engineer-in-charge.**
- (v) The contractor **shall not be eligible for any claim or compensation either arising Out of any delay in the work or due to any corrective measure required to be taken on account of and as a result of testing of the materials.**
- (vi) The contractor or his authorised representative will be allowed to remain present in the laboratory while testing the samples furnished by him.
- (vii) **The Invoice and documents for purchasing of each Bitumen will be scrutinised by Third Party Auditor.**

2.11 Co-ordination :

When several agencies for different sub-works or the Project are to work **simultaneously on the project site there must be full co-ordination and co-operation between different contractors to ensure timely and smooth completion of the project as a whole.**

The schedule dates for completion specified in each contract shall therefore, be strictly adhered to. Each contractor may make his independent arrangement for water, power, housing etc. if they so desire. On the other hand the contractors are at liberty to make mutual agreement in this behalf and make joint arrangement with the approval of City Engineer.

No single contractor shall take or cause to take any steps or action that may cause, disruption discontent or disturbance of work, labour or arrangements etc. of other contractors in the project location. Any action by any contractor which the City Engineer in his unquestioned discretion may consider as infringement of the above code, would be considered as a breach of the contract conditions and shall be dealt with as such.

In case of any dispute, disagreement between the contractors, the City Engineer's decision regarding the co-ordination, co-operation and facilities to be provided by the contractors shall be final and binding on the contractor concerned and such a decision or decisions shall not vitiate any contract nor absolve the contractor(s) of his/their obligations under the contract nor consider for the grant for any claim or compensation.

2.12 Payments :

The contractor must understand clearly that the rates quoted are for completed work and include all costs due to labour, scaffolding, plant, machinery, supervision, electric charges, water supply charges, royalties, octroi duties, work contract tax and any other tax, and shall also include all expenses to cover the cost of night work if and when required and no claim for additional payment beyond the prices or rates quoted will be entertained.

Contractor will have to submit all relative data like levels, registers etc., required test reports, respective cross sections along with procedure of bill recording. Failing of which claim of payment will not be entertained.

Contractor should note that after claim of bill in above respective manner payment will be made positively within 30 to 45 days. No delay in start or continuation of further work shall be accepted due to lack of fund or delay in payment to the contractor.

2.13 Patented Device :

Whenever the contractor desires to use any designed devices, materials or process covered by the letter of patent or copy right, the right for such use shall be secured by suitable legal arrangement and agreement with patent owner and the copy of their agreement shall be filed with the City Engineer. If so desired by the letter.

2.14 Temporary Quarters :

The contractor shall make his own arrangement for temporary quarters required for housing to his laboureres and supervisory staff at his own cost with all necessary arrangements including the preventive measure etc. as directed by the City Engineer. **No labour hutments shall be allowed within the work site.**

2.15 Computer Facility :

The contractor shall provide One branded Laptop with internet connection and one Computer with printer of configuration as mentioned below at work site within 7 days of issue of work order for the use of TMC representative throughout the

contract period. Any maintenance and and payment of necessary charges required during contract period shall be responsibility of contractor at no extra cost.

Minimum Configuration: 14" WXGA EA Series -Intelcore i5-520M (2.40 GHz) with turbo Boost upto 2.93 GHz, 320 GB, 4 GB DDR3 SDRAM, Intel Graphics Media Acc HD, BT, VGA, Windows 7 Professional 64-Bit, 2.7 Kg, Quick web access, HDMI Out, eSATA, 1 yr Intl withMultimedia Key board, Optical mouse, multimedia kit etc. complete.

Printer : Laser Jet

Note :- Specification given under Sr.no 2.15.1is only guidelines however bestconfiguration and software should be provided related in work.

2.16 Site Office and Laboratory for the Departmental Staff

On receipt of the work order the contractor will have to erect ready made site chowky and laboratory in form of porta cabin/ container cabin. Before erecting the chowky and laboratory he shall have to obtain permission from the concern Executive Engineer and the Executive Engineer shall approve the site of the chowky and the laboratory as proposed by contractor or may allow another suitable site. The portable cabin/ container cabin shall preferably of size 12.2 x 2.5 m with 2 doors and proper ventilation. It should have toilet facility.This chowky should be exclusively for use of municipal staff only and should be installed before commencement of work. The chowky should be equipped with electric supply, fans,telephone arrangement, sufficient tables, chairs, water filter and cupboard with locking arrangement, Computer/Laptop with Internet Connection etc. No separate payment will be made for providing the chowky and ancilliary items mentioned above. The site chowky and laboratory will have to be removed from the site, leaving the site clear of all materials within the period of 7 days from the date of completion of work. In case of failure to do so, the chowky will be demolish without any intimation to the contractor at his risk and cost and no request for compensation will be entertained.

3. SAFETY MEASURES AND AMENITIES :

3.1 Safety Measures :

The contractor shall take all necessary precautions for the safety of the workers and preserving their health while working in such job as require special protection and

precaution. The following are some of the requirements listed. The contractor shall also comply with directions issued by the City Engineer in this behalf from time to time and at all times.

- 3.1.1 Providing protective footwear to workers, in situations like mixing and placing of concrete, cement mortar or bitumen mix in quarries and places where the work is done under too much wet conditions as also for movements over surfaces infested with oyster growth etc.
- 3.1.2 Providing protective head wear to workers, working in quarries etc. to protect them against accidental fall of materials from above.
- 3.1.3 Taking such normal precaution like providing hand rails at the edges of the floating platform or barges not allowing nails or metal parts or useless timber to spread around etc.
- 3.1.4 Supporting workmen with proper belt ropes etc. when working on any masts, cranes, grabs, hoist, dredgers etc.
- 3.1.5 Taking necessary step, towards training the workers concerned in the use of machinery before they are allowed to handle it independently and taking all necessary precautions in and around the areas where machine hoists and similar units are working.
- 3.1.6 Taking necessary precautions for the prevention from live electrical cables.
- 3.1.7 Making platforms, stages and temporary structures sufficiently strong so as not to cause inconvenience and risk to the workmen and supervisory staff.
- 3.1.8 Providing sufficient first aid facility at the work site to render immediate first aid treatment in case of accidents due to suffocations, drowning and other injuries.
- 3.1.9 Take all necessary precautions with regard to use of drivers.
- 3.1.10 Providing full length gum boots, leather hand gloves with fire proof apron to cover the chest and back, reaching upto knees and protective goggles for the eyes to the labourers working with hot asphalt handling, vibrator in cement concrete and also where use of any or all these items is beneficial in the interest of health and well being of the labourers in the opinion of the Engineer.

3.2 Explosives :

The contractor shall at his own expenses construct and maintain proper magazines, if such are required for the storage of explosives for use in connection with works, and such magazines being situated, constructed and maintained in accordance with Government Rules and Relevant legal provisions applicable in that behalf. The

contractor shall at his own expenses obtain such licence or licences as may be necessary for storing and using explosives. Notwithstanding that the location etc. for storage of explosives are approved by the Engineer, the Government shall not be incurring any responsibility whatever in connection with storage and use of explosive on the site or any accident or occurrence whatsoever in connection therewith, all operations in or for which explosives are employed being at the risk of contractor and upon his sole responsibility and the contractor hereby gives to government an absolute indemnity in respect thereof.

3.3 Damage by Floods or Accidents :

The contractor shall take all precautions against damage by floods or from accidents etc. No compensation will be allowed to the contractor on this account or for correcting and repairing any such damage to the work during construction. The contractor shall be liable to make good at his cost any plant or materials belonging to the Government lost or damaged by flood or from any other cause which is in his charge.

3.4 Relation with Public Authorities :

The contractor shall comply with all rules regulations by laws and directions given from time to time by any local or Public Authority in connection with this work and shall himself pay fees or charges which leviable on him without any extra cost to the Department.

3.5 Police Protection :

For the special protection of Camp and of the Contractor's works, the Department will help the Contractor as far as possible to arrange for such protection with the concerned authorities if so requested by the contractor in writing. The full cost of such protections will be borne by the contractor.

3.6 Indemnity :

The Contractor shall indemnify the Thane Municipal Corporation all actions, suits, claims and demands brought or made against him in respect of anything done or committed to be done by the Contractor in execution of or in connection with the work of this contract and against any loss or damage to the Government in consequence of any Suit or action being brought against the contractor for anything done or committed to be done during execution of the work of this contract.

3.7 Labour and General Laws :Labour Regulations

3.7.1 The contractor shall employ labour sufficient numbers either directly or through sub-contractors to maintain the required rate of progress and of quality to ensure

workmanship of the degree specified in the contract and to the satisfaction of the City Engineer.

- 3.7.2** The contractor shall not employ in connection with the works any person who has not completed his eighteenth year of age.
- 3.7.3** The contractor shall furnish to the City Engineer fortnightly distribution return of the number and description by trades of works people employed on the works.
- 3.7.4** The contractor is required to report immediately to the City Engineer any accident or unusual occurrence connected with the work and now he/they acted upon. The contractor shall also submit to City Engineer a true statement showing in respect of the second half of the preceding month and the first half on the current month.
- (1) The accidents that occurred during the said fortnight showing the circumstances under which they happened and the extent of damage and injury cause by them and
- (2) The number of female workers who have been allowed benefit under Maternity Benefit Act, 1961 or Rules made thereunder and the amount paid to them.
- 3.7.5** The contractor shall pay to the labour employed by him either directly or through sub contractor wages not less than fair wages as defined in the contract labour regulations as contained hereinafter in regards to all matters provided therein.
- 3.7.6** The contractor shall comply with the provisions of the payment Wages Act, 1936, Minimum Wages Act, 1948, Employees Liability Act, 1937, Workmen's Compensation Act, 1923, Industrial Disputes Act, 1947 and the Maternity Benefit Act, 1961, the contract Labour (Regulation & Abolition) Act, 1970, and the Interstate Migrant workman (Regulation of employment and conditions of service) Act, 1979, or any modification thereof or any other law relating thereto and rules made thereunder from time to time.
- 3.7.7** The contractor shall indemnify Thane Municipal Corporation payments to be made under and for the observance of the Regulations aforesaid without prejudice to his right to claim indemnify from his sub-contractors.
- 3.7.8** The decision of the City Engineer in matters relating to the reports from the Inspecting Officers, as defined in "Contractor Labour Regulation" (Contained hereinafter) shall be final and binding and deductions for recovery of any liquidated damages in this respect may be made from any amount payable to the contractor.

3.8 Model Rules for Labour Welfare :

Signature of Contractor

No. of Corrections

City Engineer
TMC, Thane

The contractor shall at his own expenses comply with or cause to be complied with the Model Rules for Labour Welfare as contained hereafter or rules framed by Department from time to time for the protection of health and for making sanitary arrangements for workers employed directly or indirectly on the works. In case the Contractor fails to make arrangements as aforesaid, the Engineer in-charge shall be entitled to do so and recover the cost thereof from the contractor.

3.9 Safety Code :

The contractor shall at his own expense arrange for the safety provisions indicated hereafter or as required by the City Engineer in respect of all labour directly or indirectly employed for performance of the works and shall provide all facilities in connection therewith. In case the Contractor fails to make arrangements and provide necessary facilities as aforesaid the City Engineer shall be entitled to do so and recover the cost thereof from the contractors.

3.10 Nuisance :

3.10.1 The Contractor shall not at any time do, cause or permit any nuisance on the site or do anything which shall cause unnecessary disturbance or inconvenience to owners, tenants or occupants of other properties near the site and to the public generally.

3.10.2 The contractor shall save, harmless and indemnify the Department in respect of all claims, demands, proceedings damages, costs, charges and expenses what so ever arising out of or in relation to any such matters in so far as the contractor is responsible therefore.

3.11 Contract Labour Regulations :

3.11 Definitions :

In these regulations unless otherwise expressed or indicated the following words and expressions shall have the meaning hereby assigned to them.

- (a) Labour would mean “Workmen” as defined in Chapter-I of the Contract Labour (Regulation and Abolition) Act, 1970 as amended from time to time.
- (b) “Fair Wage” means Wages, which shall include wages for weekly day of rest and other allowances whether for time or piece work after taking into consideration prevailing market rates for similar employments in the neighbourhood and shall not be less than the minimum rates of wages fixed under the minimum Wages Act.
- (c) “Contractor” for the purpose of these Regulations shall include an agent or subcontractor employing labour on the work taken on contract.

- (d) “Inspecting Officer” means any Labour Enforcement Officer, or Assistant Labour Commissioner of the Chief Labour Commissioner Organisation.
- (e) “Form” means a form appended to these Regulations.

3.12 NOTICE AND COMMENCEMENT :

The contractor shall within seven days of commencement of the work, furnish in writing to the Inspection Officer of the area concerned the following information under intimation to the Engineer-in-charge.

- (a) Name and situation of the work.
- (b) Contractor’s name and address.
- (c) Particulars of the Department for which the work is undertaken.
- (d) Names and Addresses of sub-contractors as and when they are appointed.
- (e) Commencement and probable duration of the work.
- (f) Number of workers employed and likely to be employed.
- (g) “Fair Wage” for different categories of workers.

3.13 (i) Number of hours of work which shall constitute normal working day :

The number of hours which shall constitute a normal working day for an adult shall be 9 hours. The working day for an adult worker shall be so arranged that inclusive of intervals, if any, for rest shall not spread over more than twelve hours on any day. When an adult worker is made to work for more than 9 hours on any day or for more than forty eight hours in any week he shall in respect of overtime work be paid wages at double the ordinary rate of wages.

NOTE: The expression ordinary rate of wage means the fair wage the worker is entitled to.

(ii) Weekly day of Rest:

Every worker shall be given a weekly day of rest which shall be fixed and noticed at least 10 days in advance. A worker shall not be required or allowed to work on the weekly rest day unless he has or will have a substituted rest day on one of the five days immediately before or after the rest, provided that no substitution shall be made which will result in the worker working for more than 10 days consecutively without a rest day for a whole day.

Where in accordance with the foregoing provision a worker works on the rest day and has been given a substitute rest day he shall be paid wages for the work done on the weekly rest day at the overtime rate of wages.

3.14 Display of Notice regarding wages weekly day of rest etc.

The Contractor shall before he commences his work on contract, display and correctly maintain and continue to display and correctly maintain in a clean and legible condition in conspicuous places on the works, notices in English and in a local Indian Language spoken by majority of workers, giving the rates of fair wages, the hours of works for which Such wages are payable, the weekly rest day, workers are entitled to and name and addresses of the Inspecting Officer. The contractor shall send a copy of each of such notice to the Inspecting Officer.

3.15 Fixation of Wage Periods :

The Contractor shall fix wage periods in respect of each wages that shall be payable. No wage period shall normally exceed one week.

3.16 Payment of Wages :

- (i) Wages due to every worker shall be paid to him directly All wages shall be paid in current coins or currency or in both.
- (ii) Wages of every workers employed on the contract shall be paid, where the wage period is the week within three days from the end of the wage period, and in any other case before the expiry of the seventh day or tenth day from the end of the wage period according as number of workers does not exceed one thousand or exceeds one thousand, respectively.
- (iii) When employment of any worker is terminated by or on behalf of the Contractor, the Wages earned by him shall be paid before expiry of the day, succeeding the one on which his employment is terminated.
- (iv) Payment of wages shall be made at the work site on a working day except when the work is completed before expiry of the wage period, in which case final payment shall be made at the work site within 8 hours of last working day and during normal working time.

NOTE : The term “working day” means a day, on which work, on which labour is employed is in progress.

3.17 Register of Workmen:

A Register of workmen shall be maintained in Form-1 and kept at the work site or as near to it as possible, and the relevant particulars of every workman shall be entered therein within there days of his employment.

3.18 Employment Card :

The Contractor shall issue an employment card in Form-II each worker on the day of worker’s entry into his employment. If a worker has already any such card with his issued by the previous employer, the Contractor shall clearly endorse that employment card with relevant entries. On termination of employment the

employmentcard shall be again endorsed by the Contractor and returned to the worker.

3.19 Register of Wages etc :

- (i) A Register of wages cum muster roll in Form-II shall be maintained and kept at the work site as near to it its possible.
- (ii) A wage slip Form-IV shall be issued to every worker employed by the Contractor at least a day prior to disbursement of wages.

3.20 Fine and deductions which may be made form wages:

Wages of worker shall be paid to him without any deductions of any kind except the following:-

- (a) Fines.
- (b) Deductions for absence from duty i.e. from the place or the places where by the term of his employment he is required to work. The amount of deduction shall be proportionate to the period for which he was absent.
- (c) Deduction for damage to or loss of goods expressly entrusted to the employed persons for custody or for loss of money which he is required to account for, where such damage or loss in directly attributable to his neglect or default.
- (d) Deductions for recovery of advances or for adjustment of every payment of wages. Advance granted shall be entered in a register and
 - (i) Any other deduction which the Department may form time to time allow.
 - (ii) No fines shall be imposed on any worker save in respect of such act and omission on his part as have been approved of by the Chief Labour Commissioner.
 - (iii) No fine shall be imposed on a worker and no deduction for damage or loss shall be made from his wages until the worker has been given on opportunity of showing cause against such fines or deductions in writing.
 - (iv) The total amount of fines which may be imposed in any one wage period on a worker shall not exceed an amount due to him in respect of that wage period.
 - (v) No fine imposed
 - (vi) on a worker shall be recovered from him in installments or after expiry of sixty days from the day on which it was imposed. Every fine shall be deemed to have been imposed on the day of the act or commissions in respect of which it was imposed.

- (vi) The Contractor shall maintain both in English and the local Indian Language a list, approved by the Chief Labour Commissioner clearly stating the acts and commission for which penalty or fine may be imposed on a workmen and display it in good condition in a conspicuous place on the work site.

3.21 Preservation of Registers

The register of workman and the register of wages cum muster roll required to be maintained under these Regulation shall be preserved for 3 years after the date on which the last entry is made therein.

3.22 Enforcement :

- (i) The Inspecting Officer shall either on his own motion or on a complaint received by him carry out investigations and send a report to the City Engineer specifying the amounts representing workers dues and amount of penalty to be imposed on the Contractor for breach of these Regulations, that have to be recovered from the Contractor, including full details of the recoveries proposed and the reasons therefore. It shall be obligatory on the part of the City Engineer on receipt of such a report to deduct such amounts from payments due to the Contractor.
- (ii) The penalty for every default and breach of these Regulations shall, however be a sum not exceeding Rs.5000/-. In the event of the Contractor's default continuing in this respect, the penalty may be enhanced to Rs. 50/- per day for each day **default subject to maximum of one percent of the estimated cost of the work put to tender.**

3.23 Disposal of amount recovered from the Contractor :

The City Engineer shall arrange payment to workers concerned within 46 days from receipt of report from Inspecting Officer except in cases where the Contractor has made an appeal under Regulation 15 of these Regulations. In case where there is an appeal payment of worker's dues Would be arranged by the City Engineer wherever such payments arise, within 30 days from the date of receipt of the decision of the Regional Labour Commissioner (R.L.C.).

3.24 Welfare Fund :

All moneys that are recovered by the City Engineer by way of worker's dues which could not be disbursed to workers within the time limit prescribed above, due to reasons Such as where about of workers not being known, death of a worker etc., and also amounts recovered as penalty shall be credited to a fund to be kept under

the custody of R.L.C. for Such benefit and welfare of workmen employed by Contractors are prescribed by the Chief Labour Commissioner.

3.25 Appeal against decision of Inspecting Officer

Any persons aggrieved by decision of the Inspecting Officer may appeal against such decision to the Reaional Labour Commissioner concerned within 30 days from the date of the decision forwarding, simultaneously a copy of his appeal to the City Engineer. The decision of the Regional Labour Commissioner shall be final and binding upon the contractor and the workmen.

3.26 Representation of Parties :

- (i) A workmen shall be entitled to be represented in any investigaiton or enquiry under the regulations by an officer or a registered trade union of which he is a member or by any Officer or a federation of trade union to which the said trade union is affiliated or where the workmen is not a member of any registered trade union, by an officer of a registered trade union connected with or by any other workmen employed in the industries in which the workmen is employed.
- (ii) A Contractor shall be entitled to be represented in any investigation or/enquiry under these regulations by an officer of an Association of Contractors of which he is a member or by a an officer of a federation or Associations of contractors to which the said Association is affiliated or where the contractor is not a member of an association by an Officer of association of employers, connected with or by any other employer engaged in the industries in which the contractor is engaged.
- (iii) No party shall be entitled to be represented by legal practitioner in any investigation or enquiry under these regulations.

3.27 Inspection of Books and other Documents

The Contractor shall allow Inspection of the registers and other documents prescribed under these regulations by Inspecting Officer and the City Engineer his authorized representative at any time and by the worker or his agent no receipts of due notice at a convenient time.

3.28 Amendments :

Thane Municipal Corporation may from time to time add to or amend these regulations and issue such directions as it may consider necessary for the proper implementation of these regulations or for the purpose of removing any difficulties which may arise in the administration thereof.

FORM - I
REGISTER OF WORKMEN
(Regulation - 7)

- i) Name and Address :
of the Contractor
- ii) Number and Date of :
the Contract
- iii) Name and Address of :
the Department awarding
the Contract
- iv) Nature of Contract :
and Location of work
- v) Duration of the :
Contract

Sr.No.	Name & Surname of the Worker	Age & Sex	Father's/Husband's Name	Nature of Employment / Designation	Permanent Home Address of Employees
1	2	3	4	5	6

Present Address	Date of commencement of Employment	Date of Termination or leaving Employment	Signature or Thumb Impression of Employee	Remarks
7	8	9	10	11

Signature of Contractor

No. of Corrections

City Engineer
TMC, Thane

FORM - II**EMPLOYMENT CARD
(Regulation - 8)**

- i) Name and sex of worker :
- ii) Father's/ Husband's Name :
- iii) Address :
- iv) Age and Date of Birth :
- v) Identification Marks :

Particular's of next of kin (wife/husband) and children, if any, or of dependant next of kin in case the worker has no wife/husband or child.

Name :-

Full address of Dependants :

(Specify village, District & State)

Sr. No.	Name & Address of Employer (Specify whether contractor or a Sub-Contractor)	Particular's of location of work site and description of work done	Total period during which employed From To	Actual number of days worked.
1	2	3	4	5

Leave taken (No. of days should be specified)	Nature of Work done by the worker	Wage Period	Wage Rate (with particulars of unit in case of piece work)	Total wage earned by the worker during the period shown under Col.5	Remarks of the Employer	Signature
6	7	8	9	10	11	12

Signature of Contractor

No. of Corrections

City Engineer
TMC, Thane

N.B. For a worker employed at one time on piece work basis and at another on daily wages relevant entries in respect of each of employment should be made separately.

FORM - III
REGISTER OF WAGES CUM MUSTER ROLL
(Regulation)

- i) Name and Address of the Contractor :
 ii) Number and Date of the Contract :
 iii) Name and Address of the Department :
 awarding the Contract
 iv) Nature of contract and Location of work :
 v) Duration of the Contract :
 vi) Wage period

:

Sr. No.	Name Surname of the worker	Father's/Husband's Name	Sex	Designation and Nature of work 1,2,3 upto 31)	Daily attendance (No. of units worked)	Total attendance Unit
1	2	3	4	5	6	7

Fair Wages available		Wages paid		Overtime worked			Total Wages paid
Basic	D.A. & Other allowance	Basic	D.A. & Other allowance	Date	No. of hours	Overtime wages earned	
8	9	10	11	12	13	14	15

Deduction from Wages					Net Wages	Date of Payment	Signature or thumb impression of worker	Remarks
Fines	Deduction for damages	House Rent	Recovery	Other deduction				
16	17	18	19	20	21	22	23	24

Signature of Contractor

No. of Corrections

City Engineer
TMC, Thane

Reasons to be recorded in column 24.

Signature of Contractor

No. of Corrections

City Engineer
TMC, Thane

FORM - IV
(Regulation 9)

- i) Name of the Contractor :
- ii) Place :

-
- 1) Name of worker with father/husband's name :
- 2) Nature of Employment :
- 3) Wage period :
- 4) Rate of Wage Payable :
- 5) Total attendance/units of work done :
- 6) Dates of which overtime worked :
- 7) Overtime wages :
- 8) Gross wages payable :
- 9) Total deductions (including nature of deductions) :
- 10) Net wages payable :
-

**Contractor's Signature/
Thumb impression**

**Employee's Signature/
Thumb impression**

Signature of Contractor

No. of Corrections

City Engineer
TMC, Thane

3.29 Model Rules for Labour Welfare

Definitions :

(a) Work Place:

“Work Place” means a place at which on an average 20 or more workers are employed.

(b) Large workplace :

“Large Work Place” means a place at which on average 500 or more workers are employed.

First Aid :

At every work place, there shall be maintained in a readily accessible place first aid appliances including an adequate supply of sterilized dressings and sterilized cotton wool as prescribed in the factory rules of the State in which the work is carried on. The appliance they shall be placed under the charge of responsible person who shall be readily available during working hours.

At large work places where hospital facilities are not available within easy distance of the works, first-aid posts shall be established and be run by a trained compounder. Where large work places are remotely situated and far away from regular hospitals indoor wards shall be provided with one bed for every 250 employees.

Where large work places are situated in cities, towns or in their suburbs and no bed are considered necessary owing to the proximity of city to town hospitals, suitable transport shall be provided to facilitate removal of urgent cases to those hospitals. At other work places some conveyance facilities shall be kept readily available to take injured person or persons suddenly taken seriously ill, to the nearest hospital.

At large work places there shall be provided and maintained an Ambulance room of the prescribed size of such medical and nursing staff as may be prescribed. For this purpose the relevant provisions of the Factory Rules of the State Government of the Area where the work is carried on may be taken as the prescribed standard.

Accommodation for Labour :

The Contractor shall during the progress of the works provide, erect and maintain necessary temporary living accommodation and ancillary facilities for labour at his own expenses and to standards and scales as approved by the City Engineer.

Drinking Water :

In every working places there shall be provided and maintained at suitable places, easily accessible to labour a sufficient supply of cold water fit for drinking. Where

drinking water is obtained from an intermittent public water supply each work place shall be provided with storage where drinking water shall be stored.

Every water supply storage shall be at a distance of not less than 15 meters from any latrine, drain or other source of pollution where water has to be drawn from an existing well, which is in proximity of latrines, drain or any other source of pollution, the well shall be properly chlorinated before water is drawn from it for drinking. All such wells shall be entirely closed in and be provided with a trap door which shall be dust and water proof.

A reliable pump shall be fitted to each covered well, the trap door shall be kept locked and opened only for cleaning or inspection which shall be done at least once a month.

Washing and Bathing Places :

Adequate washable and bathing places shall be provided separately for men and women. Such places shall be kept in a clean and drained condition.

Scale of Accommodation in Latrines and Urinals :

There shall be provided within the premises of every work place, latrines and urinals in an accessible place, and the accommodation separately for each of these, shall not be less than at the following scales

	No. of Seats
(a) Where number of persons does not exceed 50.	2
(b) Where number of persons exceeds 50 but does not exceed 100.	3
(c) For additional persons 3 per. 100 or part thereof.	

In particular cases, the Engineer-in-charge shall have the power to vary the scale, where necessary.

Latrines and Urinals :

Except in work places provided with water flushed latrines connection with a water borne sewage system, all latrines shall be provided with receptacles on dry earth system which shall be cleared at least four times daily and at least four times daily and at least twice during working hours and kept in a strictly sanitary condition. Receptacles shall be tarred inside and outside at least once a year.

If Women are employed, separate latrines and Urinals, screened from those for men and marked in the vernacular in conspicuous letters, "FOR WOMEN ONLY", shall

be provided on the scale laid down in rule 6. Those for men should be similarly marked "FOR MEN ONLY". A poster showing the figures of a men and of a women shall also be exhibited at the entrance to latrines for each sex. There shall be adequate supply of water close to latrines and Urinals.

Construction of Latrines :

Inside wall shall be constructed of masonry or other non absorbent materials and shall be cement washed inside and outside at least once a year. The dates of cement washing shall be noted in a register maintained for the purpose and kept available for inspection, latrines shall have at least thatched roof.

Disposal of Excreta :

Unless otherwise arranged for by the local sanitary authority arrangement for proper disposal of excreta by incineration at the work place shall be made by means of suitable incinerator approved by the local medical, health and municipal authorities. The Contractor shall, at his own expenses, carry out all instructions issued to him by tile City Engineer to effect proper disposal of excreta and other conservancy work in respect of contractor's work people or employees on the site. The contractor shall be responsible for payment of any charges which may be levied by municipal authority for execution of such work on his behalf

Provision of Shelter during Rest :

At every work place there shall be provided free of cost four suitable sheds, two for meals and two others for rest separately for use of men and women labour. Height of each shelter shall not be less than 3 meters from floor level to lowest part of the roof Shed shall be kept clean and the space provided shall be on the basis of at least 0.5 sq. meter per head.

Creches :.

At a place at which 20 or more women workers are ordinarily employed, there shall be provided at least one hut for use of children under the age of 6 years, of such 1 women.

Huts shall not be constructed of a standard lower than that of thatched roof, mud floor and walls with wooden planks spread over mud floor and covered with matting. Huts shall be provided with suitable and sufficient opening for light and ventilation. There shall be adequate provision of sweepers to keep the places clean. There shall be two "Dais" in attendance. Sanitary utensils shall be provided to the satisfaction of local medical, health and municipal or cantonment authorities. Use of huts shall be restricted to children, their attendants and mothers of children.

Where the number of women workers is more than 25 but less than 50, the Contractor shall provide at least one Hut, one Dai to look after the children of women workers, size of the creche(s) shall vary according to the number of women workers employed. Creche(s) shall be properly maintained and necessary equipment like toys etc., provided.

Canteen :

A cooked food canteen on a moderate scale shall be provided for the benefit of Workers wherever it is necessary.

Planning sitting and erection of the above mentioned structures shall be approved by the City Engineer and the whole of such temporary accommodation shall at all times during the progress of the works be kept tidy and in a clean and sanitary condition to the satisfaction of the City Engineer and at the Contractor's expenses. The Contractor shall conform Generally to sanitary requirements of local medical, health and municipal or cantonment authorities and at all times adopt, such precautions as may be necessary to prevent soil pollution of the site. On completion of the works the whole such temporary structures shall be cleared away, all rubbish burnt, excreta or other disposal pits ortrenches filled in and effectively scaled off and the whole of site left clean and tidy to the entire satisfaction of the City Engineer at the Contractor's expenses.

Anti Malarial Precautions :

The Contractor shall, at his own expenses, conform all anti-malarial instructions given to him by the Engineer-in-charge, including the filling up of any borrow pits which may have been dug by him.

3.30 Nothing payable for extra facilities :

These are minimum facilities required to be provided. If the contractor gives any extra facility, the Thane Municipal Corporation will not compensate him for that.

3.31 Enforcement :

The inspecting Officer or any other officer nominated in this behalf by the City Engineer shall report to the City Engineer all cases of failure to comply with the provisions of these Rules either wholly or in part, specifying the penalties to be levied for such breach of these provisions.

3.32 The sum to be levied as penalty shall, however, be fixed in accordance with provision of clause 13(ii) of safety code.

1. DEFINITIONS :

Unless excluded by or repugnant to the context.

- (a) The expression “TMC” as used in the tender papers shall mean the Thane Municipal Corporation, Thane.
- (b) The expression “Department” as used in the tender papers shall mean the Public Works Department of the Thane Municipal Corporation, Thane.
- (c) The expression “City Engineer” as used any where in the tender papers shall mean City Engineer, of the Public Works Department, Thane Municipal Corporation Thane who is designated as such for the time being in whose jurisdiction the work lies or the officer to whom the function of the City Engineer may be subsequently transferred.
- (d) The expression Plant as used in the tender papers shall mean every machinery necessary or considered necessary by the City Engineer to execute; construct complete and maintain the works and used in altered, modified, substituted and additional work, ordered in the time and manner herein provided and all temporary materials and special and other articles of appliances of every sort, kind and description whatsoever intended or used therefor.
- (e) “Drawing” shall mean the drawings referred to in specifications and any modifications Of such drawings approved in writing by Engineer and such other drawings as may from time to time be furnished or approved in writing by the City Engineer.
- (f) “City Engineer's Representative” shall mean an assistant of the City Engineer i.e. rank of Executive Engineer who will be called as Engineer-in-charge of work notified in writing to the Contractor by the City Engineer.
- (g) The “Site” shall mean the lands and /or other places on, under, in or through which the work is to be executed under the contract including any other lands or place which may be allotted by Thane Municipal Corporation or used for the purpose of contract.
- (h) Part(s) thereof as the case may be and shall include all extra or additional, altered or substituted works as required for performance of the Contract.
- (i) The “Contract” shall mean the notice of tender, the sealed quotation and the tender documents including the tender and acceptance thereof together with the documents referred to therein, and the accepted conditions with annexure mentioned therein including any special conditions, specifications, designs, drawings, priced schedule/bill of quantities and schedule of rates. All these documents taken together shall be deemed to form one contract and shall be complementary to one another.

- (j) The “Contractor” shall mean the individual or firm or company whether incorporated or not, undertaking the work and shall include legal representative of such an individual or persons comprising such firm or company as the case may be and permitted, assigns of such individual or firm or company.
- (k) The “Contract sum” shall mean the sum for which the tender is accepted.
- (l) A “Day” shall mean a day of 24 hours from midnight to midnight irrespective of the number of hours worked in that day.
- (m) A “Week” shall mean seven consecutive days without regard to the number of hours worked in any day in that week.
- (n) “Excepted Risks” are risks due to riots (other wise than among contractor’s employees) and civil commotion (in so far as both these are un-insurable) war (whether declared or not), invasion, act of foreign enemies, hostilities, civil war, rebellion, revolution, insurrection, military or usurped power, any acts of God, such as earthquake, lightening and un-precedented floods over which the contractor has no control.
- (o) “Temporary works” shall mean all temporary works of every kind required in or about the execution completion or maintenance of the works.
- (p) “Urgent works” shall mean any measures which, in the opinion of the City Engineer, become necessary during the progress of the works to obviate any risk or accident or failure or which become necessary for security of the work or the persons working, thereon.
- (q) Where the context so requires, word importing the singular number only also include the plural number and vice-versa.
- (r) Wherever there is mention of “Schedule of rates” or simply D.S.R. or Schedule Rates in this tender it will be taken to mean as the Schedule of the rates of Public Works Department, Thane Circle.

2. LEVELLING INSTRUMENTS :

If measurement of items of the work are based on volumetric measurements calculated from levels taken before and after construction of the item, a sufficient number of levelling instruments, staves, tapes etc. will have to be kept available by the contractor at road site of work for this purpose including theodolite. All instruments must be kept at road site available for use to TMC staff. Lack of such levelling instruments, staves, tapes etc., in required numbers may cause delay in measurements and the work. The contractor will therefore to keep sufficient number of these readily available at site.

Signature of Contractor

No. of Corrections

City Engineer
TMC, Thane

6. COLLECTION OF MATERIALS :

- (i) The contractor or piece worker shall make his own arrangements to obtain the material from existing or a new quarries but before starting collection the quarry shall be got approved by the City Engineer or his representatives. The contractor or piece worker shall pay all royalty charges, compensation etc. No claims or responsibility on account of any obstructions caused to execution of the work by difficulties arising out of private owners of land, will be entertained.
- (ii) No material shall be removed from the land touching it without the written permission of the City Engineer or his authorised representative. If any material is unauthorisedly obtained from such places, the contractor or piece worker shall have to make good the damage and pay such compensation, in addition as may be decided by the City Engineer and will have to stop further collection.
- (iii) Any material that falls on any Thane Municipal Corporation Road from the carting truck or other plant etc. during, conveyance shall be immediately picked up and removed by the contractor or piece worker, failing which it be got removed departmentally at his cost. No heap shall be left prior to stacking even temporarily on the road surface or in any way so as to cause any obstruction or danger to the traffic. The contractor or the piece worker shall be liable to pay claims or compensation etc. arising out of any accident etc. Any such materials causing obstruction or danger etc. will be got removed departmentally at his cost and no claims for any loss or damage to the material thus removed will be entertained. The contractor shall also be responsible for the damage or accident etc. arising out of any material that falls on the road or track not in charge of the department and shall attend to any complaints which may be received.
- (iv) The materials shall not be collected in place where it is liable to be damaged or lost due to traffic passing over it, to be washed away by rain or floods to be buried under the land slide etc. or to slip down of embankment or hill side etc. No claims for any loss due to these and similar cause will be entertained.
- (v) Rubble/metal shall be free from all earth, rubbish, vegetable matter and other extraneous substances and in the case of metal, screened to gauge, if so

directed when ready, it shall be collected entirely clear of the roadway, on ground which has been cleaned of vegetation and levelled.

- (vi) The size of the stacks like rubble shall be of such size as may directed by the City Engineer and all stacks shall be of the same uniform size and shall be uniformly distributed over whole lengths.
- (vii) The representative of the Engineer-in-charge shall supply the contractor with statement showing Sub Km., wise quantities that will be required in the order in which the utilisation is to be done. Any excess quantity shall be removed at the expenses of the contractor before the material in the length is finally measured.
- (viii) If directed, the material shall be collected in the following order according to availability of space : (1) Rubble (2) Metal (3) Soft Murum and (4) Hard Murum, shall be collected on the side opposite to that on which soft murum has been collected. Similarly metal collected for petty repairs shall be stacked on the opposite to metal for new layer.

All road materials shall be examined before it is spread. The labour for measurements (and check measurements wherever carried out) shall be supplied by the contractor or piece worker. If the contractor or piece worker fails to attend the measurements of material after receiving the notice from the Engineer's representative or his subordinate stating date and time of intention of measuring the work, the work shall be measured exparte and no complaint in this respect will be entertained later on. If the contractor or piece worker fails to attend the measurement of material after receiving the notice form the Engineer's representative or his subordinate stating date and time of intention of measuring the work, the work shall be measured exparte and no complaint in this respect will be entertained later on. If the contractor or piece worker fails to supply sufficient labour or the materials required at the time of measurements or check measurement, after due notice has been given to him, the expenses incurred on account of employing departmental labour or material etc. shall be charged against his account.

7. MISCELLANEOUS

- 7.1** Rates shall be inclusive of Work Contract Tax, Sales Tax and all other taxes etc. and LBT as stated in para 2.12 of this chapter, except exemption may be given for plant and machinery used for the this work after paying deposit in TMC.
- 7.2** In case it becomes necessary for the due fulfillment of contract for the contractor to occupy land outside the department limits, the contractor will have to make his own

Signature of Contractor

No. of Corrections

City Engineer
TMC, Thane

arrangements with the land owners and to pay such rent if any payable as mutually agreed between them.

- 7.3** The special provision in detailed specifications or wording of any item shall gain precedence over corresponding contradictory provision, (if any), in the M.O.R.T.H specifications, the Maharashtra P.W.D. Standard specifications where reference to such specifications is given without reproducing the details in contract.
- 7.4** It is presumed that the contractor has gone carefully through the M.O.R.T.H specifications Maharashtra P.W.D, Standard specifications, IRC specifications, guidelines and the schedule of rate, all condition of the contract and Studied the site condition before arriving at rates quoted by him. Decision of the City Engineer shall be final as regards interpretation of specification.
- 7.5** The collection and storage of construction materials at site shall be in such a manner as to prevent deterioration intrusion, of foreign matter and to ensure the preservation of their quality, properties and fitness for the work. Suitable precautions shall be taken by the contractor to protect the material against atmospheric actions, fire and other hazards. The materials likely to be carried away by wind shall be stored in suitable stores or with suitable barricades and where there is likely hood of subsidence of soil, such heavy materials shall be stored on paved platforms.
- 7.6** The contractor shall be responsible for making good the damages done to the existing property or work during construction by his men.
- 7.7** If it is found necessary from safety point of view to test any part of the structure, the test shall be carried out by the Contractor with the help of the department at his own cost.
- 7.8** **Defective work is liable to be rejected at any stage. The contractor, on no account can refuse to rectify the defects merely on reasons that further work has been carried out. No extra payment shall be made for rectification.**
- 7.9** In the absence of specific directions to the contrary, the rates and prices inserted in the items are to be considered as the full inclusive rates and prices for the finished work described there under and are to cover all labour, materials, wastage, temporary work, plant, overhead charges and profits, as well as the general liabilities, obligations and risks arising out of the General Condition of Contract.
- 7.10** The quantities set down against the item in the Schedule "B" are only estimated quantities of each kind of work included in the contract and are not to be taken as a guarantee that the quantities in the schedule will be carried out or required or that they will not be exceeded or reduced.

- 7.11** All measurements will be made in accordance with the methods indicated in the elaborated in the Technical specifications, incorporated in the tender document.
- 7.12** The details shown on drawing and all other information pertaining to the works shall be treated as indicative and provisional only and these are liable to variation as found necessary while preparing working drawing which will be supplied by the Thane Municipal Corporation. The contractor shall not, on account of such variation be entitled to any increase over the already quoted rates in the tender which are on quantity basis.
- 7.13** Protection of underground telephone cable and aerial telephone wires and Poles, transmission towers, electrical cables and water supplying lines is the responsibility of the contractor.

During the execution of work, it is likely that the contractor may meet with telephone cable, electrical cables, water supply lines, effluent pipe line, oil pipe line etc. it will therefore be the responsibility of the contractor to protect them carefully. All such cases should be brought to the notice of the City Engineer by the contractor and also to the concerned Department. **Any damage whatsoever done to these cables and pipe lines by the Contractor shall be made good by him at his cost.**

8 LINING OUT :

The Contractor shall provide free of charge all labour and material and instruments required for lining out, surveying, inspection decided by the City Engineer as considered necessary for the proper and systematic execution of the work.

The department will only show the changed point on the alignment of road and it will be the responsibility of the contractor to correctly align the road between points including setting out curves etc. The Department will render necessary assistance. Likewise, only one Bench Mark with definite value of R.L. will be shown to contractor who shall have to provide for a network of temporary bench mark all along the road and near C.D. works for executing the work. The contractor shall be responsible for the provision, accuracy and maintenance of temporary Bench Mark. He shall be responsible for the correctness of the position, levels, dimension and alignments of all parts of the works and provisions of necessary instruments and labour in connection with suitable pointed bamboos or wooden stack shall be provided at his cost and firmly fixed at every meters on both sides of embankment to indicate final as well as intermediate height of the embankment. Any errors in position, levels, dimension and alignment, etc. shall be rectified, by contractor at his expenses. The checking or inspection of any setting out of any line or level or work by City Engineer or his representative shall not in any way relieve the contractor of

his responsibility for correctness thereof. The contractor shall carefully protect and preserve all bench mark, side rails pegs and stones etc., marking out the centre lines of C.D. works, necessary approaches etc. shall be done by the contractor at his own cost as directed by the City Engineer or his representative.

9. PRIORITIES OF WORK TO BE EXECUTED :

Priorities for items to be executed shall be determined periodically keeping in view the final time limit allowed for the work.

10 HANDING OVER OF WORK :

All the work and materials before finally taken over by Thane Municipal Corporation, will be the entire liability of the contractor for guarding, maintaining and making good any damages of any magnitude. Interim payments made for such work will not alter this position.

11 DISPUTES AND ARBITRATION :

11.1 No Arbitration is allowed.

11.2 In case of **disputes or difference of opinion** arising between the City Engineer and the Contractor, the Contractor refer the matter to the Commissioner through the City Engineer with an advance copy to the Commissioner and the **decision of Commissioner will be final** in this case.

12 TESTS :

12.1 The contractor shall at his own cost arrange to carry out the all tests of materials which are to be used on the work. The tests will have to be carried out either in the field laboratory or in an approved laboratory suggested by T.M.C. Routine Test shall mean testing of aggregates for gradation flakiness index, impact value, binder content and field density etc. Chart showing frequency of tests is attached in APPENDIX-III

12.2 Department will also carry out some of above mentioned tests independently in Laboratory and testing charges thereof will be borne by the contractor. Also the **work portion where test results are not satisfactory will have to be removed and redone at the cost of the contractor.**

12.3 Before beginning of the work and in intervals tests will be carried out by the contractor to determine the, quantities necessary for achieving the required compacted thickness of all types of B.T. work. These results will be guiding actor for execution of work. However, the contractor is responsible to give correct compacted thickness of the work of all types of B.T. and other relevant items.

- 12.4** In case of materials procured by the Contractor, testing as required by the codes and specifications, the same shall be arranged by him at his own cost. at the nearest approved Laboratory. If additional testing other than as required by specification is ordered, the testing charges, shall be borne by the contractor.
- 12.5** The Cubes (3 nos) shall be tested three day, 3cubes for Seven Days strength at the site laboratory in the presence of Engineer-in-charge of the work. Whenever the material cubes and beams of 28 days (3 nos each) strength are required to be sent to the Municipal Laboratory then the same shall be transported by the contractor and got tested at their own cost.
- 12.6** 10 % of the rate of the item shall be withheld and shall be released only after receipt of satisfactory test results whenever specified.
- 12.7** **The Invoice and documents for purchasing of each Bitumen will be scrutinised by Third Party Auditor and the reports will be submitted by the contractor at his own cost**

13 FINAL BILL :

- 13.1** The contractor should submit final bill within one month after completion of the work and the same will be paid within 6 months if it is in order. Disputed items and claims, if any shall be excluded from the bill and settled separately later on.
- 13.2** Bills for extra work or for any claim shall be paid separately apart from the interim bills for the main work. The payment of bills for the main work shall not be withheld for want of decision on the extras on claims not covered in the stipulation of the contract.
- 13.3** Claims for extra work shall be registered within 30 days of occurrence of the event or in any case not later than 30 days of submission of final bill by contractor . However, bills for these claims including supporting data/details may be submitted subsequently to the City Engineer.

14 ELECTRIC POWER :

- 14.1** Arrangements for obtaining Electric Power connection will have to be made by the contractor at his own cost.

15 PRELIMINARY ARRANGEMENTS :

- 15.1** The Contractor except as provided in schedule "B" which follows, shall, if necessary construct, temporary roads and maintain these in proper condition till the completion of the work at his own cost. If necessary, he shall also, at his own

expenses make necessary arrangements for acquisition of land required by him in connection with execution of the work.

15.2 The Contractor shall have to make at his own cost all preliminary arrangements for labour, water, electricity and materials etc., immediately after getting the work order. No claim for any extra payment or application for extension of time on the grounds of any difficulty in connection with the above matter, will be entertained.

15.3 The contractor shall at his own expenses engage watchman for guarding the materials and plants and machinery and the work during day and night against any pilferage or damages and also for prohibiting trespassers or damage to them. Failing, Corporation may engage this without intimation to contractor and payment will be recovered through R.A. bills.

15.4 The Contractor shall have to make his own arrangements for water required for watering the embankment or for any other purpose.

16. INSPECTION :

16.1 The contractor shall inform the City Engineer in writing when any portion of the work is ready for inspection giving him sufficient notice to enable him to inspect the same without affecting the further progress of the work. The work shall not be considered to have been completed in accordance with the terms of the contract until the City Engineer shall have certified in writing to that effect. No approval of materials or workmanship or approval of part of the work during the progress of execution shall bind the City Engineer or in any way affect him even to reject the work which is alleged to be completed and to suspend the issue of his certificate of completion until such alternations and modifications or reconstruction have been effected at the cost of the contractor as shall enable him to certify that the work has been completed to his satisfaction.

16.2 The contractor shall provide at his cost necessary ladders and such arrangements as to provide necessary facilities and assistance for proper inspection of all parts of the work at his own cost.

16.3 The contractor after completion of work shall have to clean the site of all debris and remove all unused materials other than those supplied by the Department and all plant and machinery, equipment, tools etc., belonging to him within one month from the date of completion of the work, or otherwise the same shall be removed by the Department at his cost and the contractor shall not be entitled for payment of any compensation for the same.

17 PLANT :

All constructional plant, provided by the contractor shall when brought on to the site be deemed to be exclusively intended for the construction of this work and contractor shall not remove the same or any part thereof (say for the purpose of moving it from one part of the site to another or the repairs etc.) without the consent in writing of the City Engineer which shall not be unreasonably withheld.

18 AUTHORITIES TO THE CITY ENGINEER REPRESENTATIVE :

18.1 The City Engineer may from time to time, in writing delegate to his representative any powers and authorities vested in the City Engineer and shall furnish to the contractor a copy of all such delegations of powers and authorities. Any written instructions of approval given by the representative of the City Engineer to the contractor within the terms of such delegations (but not otherwise) shall bind the contractor and the department as though it had been given by the City Engineer provided always as follows :-

18.2 Failure of the representative of the City Engineer to disapprove any work or materials shall not prejudice the power of the City Engineer thereafter to disapprove such work or materials and to order the pulling down, removal or breaking up thereof.

18.3 If the contractor shall be dissatisfied with any decision of the representative of the Engineer-in-charge, he shall be entitled to refer the matter to the Engineer in-charge, who shall there upon confirm reverse or vary such decision.

19. EXCEPTED RISKS :

The contractor shall be under no liability whatsoever by way of indemnity or otherwise for or in respect of destruction of or damage to the works (save work condemned under the provisions of specifications and conditions of this tender prior to the occurrence of any excepted risk hereinafter mentioned) or temporary works or to property whether of the Department or third parties or in respect of injury or loss of life which is the consequence whether direct or indirect, war hostilities (whether war be declared or not) invasion, act of foreign enemies, rebellion, revolution, insurrection or military of usurped power, civil war or riot, commotion or disorder otherwise than among the contractor's own employees or his piece worker and sub-agencies (hereinafter comprehensively referred to as "the said excepted risks") and the Department shall indemnify and save harmless the contractor against and from the same and against and from all claims, demands, proceedings, damages, costs charges and expenses, whatsoever arising thereout or in connection therewith and

shall compensate the contractor for any loss of or damage to property of the contractor used for intended to be used for the purpose of the works and laying at site of work and occasioned either directly or indirectly by the said excepted risks.

19.2 If the works sustain destruction or drainages by reasons of any of the said excepted risks, the contractor shall be entitled to payment for any permanent works and for any materials so destroyed or damaged and shall be paid by the department the cost of making good tiny such destruction or damages whether to the works or Temporary works and for replacing, or making good Such materials so far as may be necessary for the completion of the works on a prime costs basis as the City Engineer may certify to be reasonable. The contractor shall lodge his claim, in writing, supported by City Engineer immediately, but not later than 30 days of such occurrence of damage to works by excepted risk.

19.3 Destruction, damage injury or loss caused by the explosion or impact whenever and wherever occurring of any mine, bomb, shell, grenade or other projectile missile or ammunition or explosive or was resulting from action described in 19.1 above shall be deemed to be a consequence of the said Excepted Risks.

20. ADDITIONAL WORKS SPECIFIC ACTIONS :

20.1 The whole work shall be carried out strictly in accordance with the approved detailed drawing (unless otherwise directed) description of the items, detailed specification of latest revision of M.O.R.T.H for Bridge and Road Works April 2013 (with Indian Standard specification indicated therein) subject to the additional specification given for the relevant items and in the best workmen like manner and P.W.D. specification.

20.2 While adopting the relevant number and pages for different items of the M.O.R.T.H specifications for Bridges and Road Works, April 2013 or P.W.D., Standard Specification Books, due care has been taken to indicate correct number and page for the various items. However if for some reasons or other it is noticed that the specification numbers and pages quoted are not pertinent, the contractor is bound to carry out the work in accordance with the correct relevant specifications for the item or items from the standard specification Book, after taking into account the description of the items, scope and spirit of the work.

20.3 During the course of the execution, payment for certain items such as R.C.C. works and the like which are done in stages, shall be made at part rates which shall be decided by the City Engineer. Similarly in case if certain component or components of an item are decided to be deleted, payment for the remaining parts of the items shall be made at reduced rates for such items which shall be decided by the City

Engineer, either on the basis of market rates or schedule rates or accepted tender rates whichever are lowest for such component or components.

- 20.4** It is to be definitely and clearly understood that the specification stipulated shall be rigidly enforced and no relaxation shall be allowed. Extra charges or claims in respect of extra works shall not be entertained unless they are clearly outside the scope of the item and its specifications to which they relate or unless such works are ordered in writing by the City Engineer and claimed for in specified manner before the same is taken in hand.

21 CONTRACTOR'S LIABILITY AND INSURANCE :

- 21.1** From commencement to completion of the works, the Contractor shall take full responsibility for the care thereof and for taking, precaution to prevent loss or damage to the greatest extent possible and shall be liable for any damage or loss that may happen to the works or any part thereof from any cause whatsoever (save and except the Excepted Risks) and shall at his own cost repair and make good the same so that at completion, the works shall be in good order and condition and in conformity in every respect with requirements of the contract and instructions of the City Engineer.

- 21.2** Without limiting his obligations and responsibilities under clause 25.2 the contractor shall insure in the joint name of the Thane Municipal Corporation and the contractor against all loss or damage from whatever cause (other than the Excepted Risks) for which he is responsible under the terms of the contract and in Such manner that the Thane Municipal Corporation and the contractare covered during the period of construction of the works and the defects liability period for loss or damage arising from a cause occurring prior to the commencement of the damage caused by the Contractor in the course of any operation carried Out by him for the purpose of complying with his obligations under clause 20 of Printed B-1 Tender Form (regarding Defect Liability).

- (i) The works and the temporary works to the full value of such works executed from time to time.
- (ii) The materials, constructional plant and other things brought to site by the in contractor to the full value of such material, constructional plant and other things.

- 21.3** The Contractor shall indemnify and keep indemnified the Thane Municipal Corporation against all losses and claims for injuries or damages to any person of contractor & TMC supervising the work or any property whatsoever which may

arise out of or in consequence of the construction and maintenance of the works and against all claims, demands, proceedings, damages, accidents, costs, charges and expenses whatsoever in respect of or in relation thereto provided always that nothing herein contained shall be deemed to render the contractor liable for in respect of or to indemnify the Department against any compensation or damage caused by “EXCEPTED RISKS”.

- 21.4** Before commencing execution of the work, the contractor shall, without in anyway limiting his obligations and responsibilities under the conditions, insure against any damage, loss or injury which may occur to any property (including that of Department) or to any person (including any employee of Department) by or arising out of carrying out of the Contract.
- 21.5** The contractor shall at all times indemnify the Department against all claims, damages or compensation under the provisions of payments of wages Act, 1936, Minimum Wages Act, 1948, Employment Liability Act, 1938, Industrial Disputes Act, 1947, and the Maternity Benefit Act, 1961 and Inter State Migrant Workmen (Regulation of Employment and Conditions of Service) Act, 1979 or any modifications thereof or any other law relating thereto, any rules made there under from time to time or as a consequence of any accident or injury to any workmen or other person in or about the works, whether in the employment of the contractor or not, save and except where such accident or injury has resulted from any act of the Department, their agents or servants and also against all costs, charges and expenses or any suit, action or proceedings arising out of such accident or injury and against all sum or sums which may with the consent of the contractor be paid to compromise or compound any such claim without limiting his obligation and liabilities as above provided the contractor shall insure against all claims, damages or compensation payable under the workmen’s Compensation Act, 1923 or , any modifications thereof any other law relating thereto.
- 21.6** All the aforesaid insurance policies shall provide that they shall not be canceled till the City Engineer has agreed to their cancellation.
- 21.7** The contractor shall prove to the City Engineer his authorised representatives from time to time that he has taken out all the insurance policies referred to above and has paid the necessary premia for keeping the policies alive till the expiry of the Defects Liability period.
- 21.8** The Contractor shall ensure that similar insurance policies are taken out by his sub-contractor (if any) and shall be responsible for any claims or losses to department resulting from their failure to obtain adequate insurance protection in connection

thereof. The Contractor shall produce or cause to be produced by his sub-contractors (if any) as the case may be relevant policy or policies and premium receipts as and when required by the City Engineer.

If the Contractor and/or his Sub-contractor (if any) shall fail to effect and keep in force the insurance referred to above or any other insurance which he/they may be required to effect under the terms of the contract then in any such case department may without being bound and to effect and keep in force any such insurance and pay such premium or premia as may be necessary for that purpose and from time to time deduct the amount so paid by the department from any money due or which may become due to the contractor or recover the same as a debt due from the contractor.

21.9 Third party insurance

Before commencing the execution of the work , the contractor (but without limiting with obligation & responsibility under clause 21.10.1 hereof) shall insure in the joint names of the employer and the contractor against any damage or lose or injury which may occure to any property or to any persom (includeing property & employes of the employer) by or arising out of the execution of the works or temporary works in carrying out of the contract, such insurance shall be affected with an Indian insurance company and in terms approved by the employer (which approval shall not be unreasonably with held) and for atleast the amount shown in the appendix to the tender as the contractor shall have to produced to the engineer in charge **thepolicy or policies of insurance and the receipt for the payment of current premiums Rs. 5 lacs has been indicated as liability of any one incident.**This shall be restored back to same value after every incident taking place till the completion of the contract.

21.9.1 Risk pending completion:

All the works of this contract until completion of contract and handling over the work to the employer shall stand at the risk of the contractor who shall be responsible and make good at his own costs all loses and damages caused by or by due to fire, weather or any other cause and the contractor shall handover such works complete in every respect on completion of works.

22 PRESERVATION OF PROPERTY :

The contractor shall take all reasonable precaution for the protection and preservation of any or all existing road side trees, drains, sewers or other surface drain pipes, conduits and any other.structure under or above ground which may be affected by the constructions, operations and which in the opinion of the Engineer shall be continued in use without any change. Safegards taken by the contractors in

this respect shall be got approved by him from the engineer. However, if any of these objects is damaged by reason of the contractor's negligence, it shall be replaced or restored to the original condition at his expense.

23 PROVISION OF LIGHTING OF WORK :

All excavations, trenches, obstructions, materials etc. taken in connection with the works would be sufficiently lighted at night in order to guard against any damage or danger to the traffic and to take all precautions to keep all the lamps lighted all night for the guidance of the traffic in the following manner

1. All lamp must be kept at a height of about 1 m to 1.25 m (3' to 4' at strategic points).
2. All lamps should be red in colour.
3. All lamps across, directions of traffic should be spread at a distance of not more than 2 m (7') apart.
4. All lamps along the line of traffic should be spaced not more than 9m to 15m (30' to 40') apart.
5. To take such other measures as may be directed by the engineer from time to time for the safety of the traffic.
6. The contractor shall make all proper provisions for protecting the work by providing portable barricades with flashers otherwise known as blinkers. Specifications of blinkers are as follows
 - a) Series 6100 blinker unit consisting of a solid state oscillator driver circuit using silicon transistor, tropicalised printed circuit card, driving a 2.4 watt filament lamp in a screw holder.
 - b) The unit contains 4 flash light cells (type 1.5 v) in a battery compartment in the base removable bottom to facilitate quick battery change.
 - c) The assembly housed in a specially shaped handy box, ms fabricated, painted in attractive traffic yellow with regulation slips on the visible base, bakelite handle on top for carrying. The side fitted with prefocussed moulded polystyrene lenses red or amber having prismatic inner surfaces for efficient light transmission. Visibility approximately 150 meters on dark night.

In the event of the contractors not complying with the provisions of the clauses, the engineer may without notices to the contractor put up the barricades or improve upon

the same or provide or improve the lighting to adopt such procedures as may be adopted by the engineer shall be born by the contractor shall be charged a penalty of Rs. 500/- per day till compliance of these requirements.

24 RAISING OR LOWERING MANHOLES, CHAMBERS, WATER ENTERANCES ETC. :

- 24.1** Required level shall be achieved in brick work as specified including plaster. The thickness of joints shall not exceed 10mm (3/8"). case The frame of manhole must rest on C.C coping
- 24.2** All frames of manholes and chambers etc. shall be kept flush with the general surface of an asphalt road/concrete pavement.
- 24.3** Valve chamber frames being on the edge of the road, shall be fixed to the correct road level .
- 24.4** A concrete pavement should be cast around the frames and covers of manholes, chambers, etc., in case of asfaltic roads.
- 24.5** The space around circular frames and covers shall be fully paved with (C.C.1: 11/2:3) as specified and directed. The pavement shall be atleast 8 centimeter (3") wider than the outer most edge of the circular frame. No payment will be made of this pavement under the item of cement concrete.
- 24.6** The space to be paved around hydrants or sluice boxes shall be 1 x 1.5m x 1.5m (5' x 5') in external measurements and in case of gas syphone or chamber 91 centimeter x 61 centimeter (3' x 2') the longer dimation being along the direction of the main.
- 24.7** In Case of rectangular frame work covers the space as directed by the engineer shall be paved with 1: 1.5:3 C.C. No payment will be made for the pavement which should be at least 8 centimeter wider than the outer most edge of the frame.

Chapter – IV

Special Conditions of Contract

Signature of Contractor

No. of Corrections

City Engineer
TMC, Thane

CHAPTER –IV

SPECIAL CONDITIONS OF CONTRACT

1.0 There may be underground services such as water supply, sewerage, electric, telephone cable etc. which may be required to be removed, shifted by the concerned authorities. No survey of underground services are carried out by TMC. As per the requirement they will have to be taken up the possible delay due to such services have to be accounted by agency though time delay could be considered on merit by no extra compensation for such delay will be made. TMC as proposed to lay water supply/sewerage lines as well as MSEDCL proposes to lay their HT cable in lieu of overhead cable to remove infringing structures in road widening. This will avoid future cutting of road.

The tenderer should carry out additional works like major/minor repairs, lowering and laying of water and sewerage lines and their required relative works as and when required, the works will be executed at the same rate of D.S.R. consider for the estimate of this work & the same tender condition as directed by engineer in charge. However City engineer will be the final authority to execute such works through labour societies or other agencies.

2.0 The contract rate shall include providing by contractor fully equipped laboratory at site as well as at the RMC plant and hot mix plant for testing materials etc. in the presence of departmental engineer or his authorised representative.

3.0 The work has to be executed true to line, levels, camber etc. The contractor shall provide sufficient surveying and mathematical instruments etc. and technical personnel so as to ensure quality of work strictly as per specifications. Camber plates and straight edges shall be provided in sufficient number on site to measure longitudinal profile and cross profile. Camber plates shall be prepared out of Alluminium. After asphalt work is completed, it shall be checked for cross profile jointly by the Contractor and Engineers of T.M.C. Correction if any shall be done by the contractor and surface shall be within tolerance limit as prescribed in latest revision of M.O.R.T.H specification of latest edition. Without record of this camber checking asphalt items payment shall not be released. The surface must be brought to the required shape given in the specification and drawing. On plant also the representative of TMC will be posted. The samples of **PMB40 & CRMB60** grade asphalt shall be checked frequently in the field laboratory and plant laboratory and record maintained in bound volumes.

Signature of Contractor

No. of Corrections

City Engineer
TMC, Thane

- 4.0** The contractor shall submit **PERT programme as well as Bar charts** depending upon site problems and review the same at very close intervals of 15 days to a month. The PERT programme and Bar charts shall detail gainful employment of mobilisation and for their flexibility depending upon availability or otherwise of work front.
- 5.0** There shall be sufficient documentation of the work in the form of test records, registers, challans survey records of levels, photographs etc. at the cost of contractor. The contractor shall provide necessary registers for recording test results jointly, forms, stationary etc. at his cost. All the test results in field and in the laboratory shall be signed by representative of contractors.
- 6.0** The Tender items of earthwork in embankment shall have its top layer with 30 cm of non plastic murum having minimum soaked C.B.R. of 6. The compaction shall be done in layers of 20 cm loose with vibratory roller at O.M.C. for 100% proctor density. The contract rate is for cross sectional measurement and items shall include providing murum laying in layers compaction with vibratory rollers and testing for laboratory and field density, C.B.R. and P.I. value. The payment will be released after satisfactory test record is produced with the bill.

7.0 L Sections - Cross Sections - Mode of Measurements :

Soon after issue of work order the contractor shall establish Bench mark on permanently fixed locations or on un-disturbed locations. Bench markings levels should be at interval, not more than 50 meter. This bench marking levels shall be got cross checked by the Dy. Engineer of T.M.C. and records shall be submitted to the City Engineer, Executive Engineer. One copy retain with the contractor. After issuing of work order and availability of the land in part or in full. The contractor shall take joint ground levels (initial levels) alongwith the Executive Engineer, or his authorised representatives and got cross checked through the Executive Engineer. He shall also survey the alignment of the road and submit copy of the joint levels and plans duly signed by himself and the representative of the Executive Engineer through the City Engineer, who shall get one set of longitudinal section including curve tables, super elevation, starting point of curve, end point of curve, plotted at 'L' section sheet as well as plotted on plans. The contractor shall issue one copy of the 'L' sections and the cross sections, including the curve tables duly signed by the City Engineer, approved by City Engineer, before commencement in further work on the road. This condition is compulsory and shall not be neglected. **In case the contractor defaults to obtain duly approved 'L' sections and cross sections from City Engineer before commencement of the work no claims/complaints**

regarding delayed payments or non-payments or not entertaining payment for excess quantity shall be entertained. The contractor shall maintain one copy of the approved 'L' sections and cross sections at the site. Along with each bill the contractor shall forward cross sectional measurements for each of items such as excavation, embankment, W.M.M. and B.M. asphalt concrete, cement concrete sections & mastic junction etc. The cross sectional measurement of bituminous items shall also be supported with weigh bridge challans of the mix. There shall be joint independent measurement of selected truck/dumper, as may be selected by Engineer or his representative in respects of bituminous mix for B.M./A.C. for independent weigh bridge. All the payments of the weigh bridge shall be made by the contractor at his cost.

The work has to be executed true to line, levels, camber etc. The contractor shall provide sufficient surveying and mathematical instruments etc. and technical personnel so as to ensure quality of work strictly as per specifications. Camber plates and straight edges shall be provided in sufficient number on site to measure longitudinal profile and cross profile. Camber plates shall be prepared out of Alluminium. After asphalt work is completed, it shall be checked for cross profile jointly by the Contractor and Engineers of T.M.C. Correction if any shall be done by the contractor and surface shall be within tolerance limit as prescribed in M.O.R.T.H specification 5th Revision April 2013. Without record of this camber checking asphalt items payment shall not be released. The surface must be brought to the required shape given in the specification and drawing. On plant also the representative of TMC will be posted. The samples of **Polymer Modified Bitumen (PMB) - 40, CRMB – 60 or any grade asphalt** shall be checked frequently in the field laboratory and plant laboratory and record maintained in bound volumes.

7(A) Plane Table Survey Work :

The Contractor should carry out the plane table survey as per the alignment & the related details of the roads, such as widths, etc.

The plane table survey will include the following salient features such as –

- i) Buildings with its name
- ii) Temporary or permanent structures
- iii) Cross roads
- iv) Culverts
- v) HT lines, Electrical poles, street lights
- vi) Existing footpaths & S.W. gutters
- vii) MTNL manholes etc.
- viii) Traffic signals

ix) Subways

The plane table survey should be completed to the scale of 1:500

The surveyor should submit five computer print outs and one tracing of the plane table survey works & levels of road at the interval of 15 m in length & 3 m in width with longitudinal section & existing cross section along with footpath at the interval of 100 m.

- 8.0** When excavated earth from the road ways, gutter etc. are required to be transported, the payment shall be against the compact quantities of transported material as per the cross sectional measurement of the excavation. It shall be so planned that the contractor shall use all the excavated approved earth in the embankment work and the excess soil only should be transported. The surplus earth to be used as indicated by the City Engineer. In case the contractor neglect to use excavated earth in the embankment by proper planning re/handling will be at his cost & necessary reduction in the excavated earth will be made in embankment. Regarding transportation of excavated earth, there shall be joint measurement of each truck/dumper with challans duly signed by the representative of the City Engineer and the contractor, both at the place of loading as well as unloading. This will serve as cross checking of work done. Mode of measurements will be as described above.

Compaction of bank work, W.M.M. shall be done by use of vibratory roller of approved capacity. Compaction of B.M./A.C. shall be done by combinations of vibratory and static rollers as per specifications of M.O.R.T.H. and direction of Engineer-in-charge. All the items shall be rolled to the required camber super elevation, density, longitudinal profile etc. and surface finish shall be within limits prescribed in M.O.R.T.H specifications. For rolling as per requirement of speed of work and quantity to be rolled number of rollers will have to be arranged by contractor. He should note that compaction to the required standards will be given top most priority. Rolling of each layer will be certified by supervisors of contractor & representative of TMC and certificate will be recorded in M.B. with date, Roller Number etc. **Concrete of all grades shall be produced in Ready mix plant & transported to site through transit mixer within the time** prescribed in IS Code. Vibration should be as per the provisions of the IS Code.

9.0 Submission of Bills by Contractor :

The contractor shall submit bills for measured quantities duly supported with joint measurements along with copies of records of test results for frequency as per specifications, accounts of bitumen purchase, use of delivery challans of mix from plant to site etc. The Executive Engineer shall check the bills, and measurements

Signature of Contractor

No. of Corrections

City Engineer
TMC, Thane

submitted by the contractor and submit the bills after joint measurements duly signed by contractor.

10.0 All the bench marks/chainage marks shall be painted and preserved till two years after completion of work by the contractor at his cost.

11.0 Asphalt challans from refinery be produced by contractor giving vehicle number for asphalt used in this work. **Please note that Polymer Modified Bitumen -40, CRMB – 60, VG- 30 grades shall only be used.** The Corporation will test grade of asphalt of any load at the cost of contractor and if it is found that **Polymer Modified Bitumen -40, CRMB – 60, VG- 30 grade** is not used as specified, the whole work done will stand rejected. Work will not be accepted at reduced rates if the grade of asphalt differs.

12.0 Centering to be used for the gutter walling and slabs shall be of steel plate or of new marine ply only. No wooden shuttering will be allowed for the concrete of gutter walling, and slab work R.C.C. slab on gutter and gutter walling shall be done with mechanical mixer and vibrator with proper curing arrangements. All the concrete shall be foam finished and no plastering shall be allowed to be done. The slab concrete shall be as per approved mix design only. The reinforcement bars shall be of tested quality. Proper cover shall be provided. The top and bottom surface shall be foamed finished. Sand having silt content less than 4% shall be allowed to use. Honey combed surface will be rejected. Kerb stone, centre line divider stones, water tables shall be manufactured in factory with required specifications of concrete on a vibrating platform. Curing shall be by dipping in water tank for 10 days period and no other curing method shall be allowed. The T.M.C. Engineer shall have right to check the quality of production in the factory/plant. All these items shall be plate vibrated and true in line level and weight. The surface shall have foam finish. The joinery of these stones and water tables shall be of good quality and shall not be more than 10 mm.

13.0 Approval to Material in Writing and Preservation of Samples :

For all the items first samples must be got approved from the Engineer Incharge. Approved samples shall be preserved in sealed plastic containers at the site office in cup-board. No work shall be done unless approval in writing is given by the Engineer for quality of material to be used. The samples shall be available in the office for shahabad stones flooring, cheque red tiles, curb stones, beams, central line divider stones, water tables, central line grill, PVC pipes to be used for cabling and all such items like metal, sand metal for WSEL/WMM/BM/AC etc. **Centering before bringing to site shall be got approved in writing from Engineer**

Incharge.The first concreting shall be done in the presence of Dy. Engineer only and it is to be shown to Engineer Incharge after removal of shuttering. After he approves the quality of finish in writing. Then further concreting shall be done. Similarly for asphalt work, WSEL work WMM work, sample stretches shall be prepared first and got approved from Engineer Incharge its quality and quantity in writing before proceeding with further work. No sub-standard work will be accepted and it will stand rejected if it does not meet specifications of MORTH and PWD standard specifications (red book). No layer of earth work, WSEL, W.M.M., B.M., shall be laid unless earlier layer compaction is approved in writing the work order book levels jointly recorded on the spot and the site inspection instructions in writing is given by the City Engineer's authorised representative. All the approvals, compaction checking, approval of stretches done. Approval of form finish, surface of gutter walling and slab, various components like kerb stone, beams, tiles, centre line stones, grill, water table, manhole covers shall be recorded in work order book and slips be pasted to samples duly signed by Engineer in charge and representative of TMC and presented till final bill is recorded.

14.0 Posting of Qualified/Experienced Engineers on Site :

The contractor shall post sufficient number of experienced Engineers on site. Engineers to be appointed on site shall be with approval of Engineer Incharge of the work from T.M.C. The contractor shall appoint at least two Engineers (Out of which at least one shall be a graduate. Civil Engineer of minimum 10 years experience) and sufficient qualified supervisors for day to day quality and quantity control, checking at all stages, checking camber, Ghani register etc.

15.0 Safety of Traffic during execution :

During the construction work proper diversion shall be maintained. Proper indicator boards shall be provided for safety of vehicular and pedestrian traffic and labour, staff working on site. Proper insurance of staff labour be drawn as indicated in contract. Safety during construction shall be given top priority and to the entire satisfaction of Engineer incharge.

Tenderer should note that, during the execution of works, debris etc. which is dumped on the public streets/footpaths/places will have to be removed immediately as per direction of Engineer in charge, failing which the same will be got removed at their risk and cost.

16.0 Approval for Cement/Steel :-

The steel and cement shall be of approved make as per instructions of Engineer in charge in writing.

Minimum Cement content shall be as follows :-

As per IS 456- 2000

M-100 -	4.40 bags / cum.
M-150 -	6.00 bags / cum.
M-200 -	7.00 bags / cum.
M-250 -	7.50 bags / cum.
M-350 -	8.25 bags / cum.
M-400 -	8.50 bags / cum.

17.0 Disposal & Transportation of Excavated Material : -

Disposal & transportation of excavated material shall be done by the contractor at his own cost as directed by Engineer-In-Charge. No extra payment will be made for loading, unloading, transportation, labour and disposal of excavated material within the lead of 50 Mtrs. If lead works out to be more than 50Mtrs in that case rates will be paid as specified in bill of quantities. Proper Account, records will have to be maintained., All the charges for the royalty if payable to collector for excavated material, which will be transported as directed by Engineer-In-Charge shall be borne by the contractor , necessary proof of receipt of having royalty paid shall be submitted along with RA bills . Necessary permission to the transportation from concerned department shall be obtained by contractor himself. TMC will extend necessary possible help in this regard. The rate quoted shall be deemed to be included above aspect.

18.0 Road closing and traffic diversion-

The contractors will have to obtain permission from the traffic police department well in advance either for closing down the road or for diversion of traffic for execution of the work. The work may be required to be executed in phases as per traffic police permission . The contractors should therefore take this factor into account while quoting. It will be the contractors responsibility to take permission from department concern's. TMC will help in issuing letter, give NOC so that authorities could give permission. In case of any delay taking place on account of such permission , TMC will not be responsible. No claim/escalation, extension of time shall be entertained on account of this. Half width of the road can be taken for construction

19.0 T.M.C. will not supply cement to contractors. They shall have to purchase cement of approved make from open market manufactured by reputed companies whose

strength of cement shall conform to I.S. 8112.1989. Cement shall have to be got tested at any approved laboratory by TMC of approved make by City Engineer at Contractor's cost before its use.

Testing : - Laboratory

Contractors must have a laboratory at plant & site at their cost for performing various tests at their cost and the following machines and equipment at least shall be provided at site,

- a) Crushing strength machine (for cube tests)
- b) Aggregate testing machine
- c) Set of appropriate sieves for finding fineness modulus and for aggregate grading.
- d) Laboratory weighing balance
- e) Aggregate drying equipment
- f) Equipment for testing of silt content in sand
- g) Equipment for testing of bitumen content & gradation for asphalt work
- h) Aggregate impact value test machines
- j) Contractor must establish this laboratory within 15 days from the date of letter of acceptance of contract. On failure to establish the laboratory in full a penalty of Rs. 300/- per week or part thereof per equipment will be imposed till the contractor procures the necessary equipment in good working condition.

Other machines as required by Engineer of T.M.C.

All the test records shall be meticulously maintained by the Contractor duly signed by Engineer In-charge of the T.M.C. in the site laboratory and made available as and when required.

Six concrete cubes shall be tested at Contractor's cost in the approved lab, for seven and twenty eight days strength as and when directed by Engineer-in-charge as a cross check or as directed in addition to usual testing at site lab. Contractor should possess adequate standard CUBE MOULDS. Specimens will be transported to any approved lab by contractor at their cost.

- 20.0** The mix design of adequate strength as required and specified by the Engineer shall be done by contractors. The mix design shall be got changed at the cost of contractor if quality of materials and gradations are changed or as may be directed by the City Engineer.

- 21.0** The mix design should confirm to one of the methods specified in & SP:23:1982 or as per IRC 44:1976 / ES 10262
- 22.0** The tenders shall submit a list of equipments, machinery possessed by them and required for execution of concrete works. **All grades of concrete shall be produces only from Ready mix plant.** No mixing of any grade of concrete will be allowed at site except for very small quantities with prior permission of Engineer-in-charge Transportation will be through transit mixer only.
- 23.0** Initial curing shall strictly be done by covering with Hessian cloth & sprinkling with water over the concreted portion as soon as the concrete starts setting. Sprinkling of water be started just after brooming the concrete surface to avoid evaporation of the water from the mix.
- 24.0** The modified Bitumen i.e. **Polymer Modified Bitumen-40, CRMB – 60, VG- 30 grade required in this work shall be purchased from Hindustan Colas ltd, Hindustan Petroleum, or other government petrolium company** only.
- 25.0** The contractor shall obtain and maintain a telephone at site at their cost till expiry of contract period within 15 days from the date of erection of site office, failing which a penalty of Rs. 300/- per day will be levied and recovered.
- 26.0** After completion of the work the contractor shall submit 3 sets of completion drawings showing therein the details of work executed including the details of SWD and their diameters, water mains laid, location of ducts, manholes and water entrances etc. as directed by the Executive Engineer. Such class shall be mounted on canvas cloth. The completed work shall be handed over to all the concerned department of TMC along with the respective ward offices with necessary plans after completion of the work.
- 27.0** Necessary traffic signs and boards including provision of traffic cones etc. for traffic diversion, closure of road, roadwork in progress, etc. as directed should be fixed by at the Contractors own cost, failing to which a penalty of Rs. 5000 /- per day shall be levied on contractor. Necessary traffic signs and boards including provision of traffic cones etc. should be provided for traffic diversion, closure of road, roadwork in progress, etc. as directed by the Contractors of their cost.
- 28.0** No extra payment will be made for the use of admixtures.
- 29.0** Day by day record of execution of work and relating technical records, registers, tests and test reports should be maintained by the contractor's engineer and duly get

checked and corrected by site incharge of TMC, which is responsibility of the contractor. Failing which, claim for the bill for such works will not be entertained.

- 30.0** Temperature of B.M. / A.C. while placing has to be maintained by contractor
- 31.0** Hot Mix plant must be fully automized and equipped with computerized machineries. Calibration of weighing balances must be checked in the presence of TMC Engineer
- 32.0** Ready mix concrete plant must be fully automized and equipped with computerized machineries. Calibration of weighing balances must checked at six month.
- 33.0** The work will be allowed in two shifts of 8 hours each i.e. by day and by night also if warranted, with proper adequate lighting arrangement at no extra cost to Corporation.
- 34.0** Contractor should remove kerb stone, water table, divider, railing and transport it free of cost to the place as suggested by Engineer-in-charge.
- 35.0** Water used for mixing and curing of concrete shall be clean and free from injurious substance like oil, salt, acid, vegetable matter and other substances harmful to the concrete. It shall meet the requirement stipulated in IS 456. The water brought for concreting and curing etc. shall be got tested from Municipal Laboratory to verify whether it is suitable for above purposes whenever directed. This testing will be done at contractor's cost

36.0 SPECIFICATIONS FOR TRAFFIC SIGNS & ROAD MARKINGS

Traffic Signs

Temporary traffic and construction signs are to be provided during construction and maintenance, operations for traffic diversion and pedestrain safety.

Road Marking

1. Road markings shall be of hot applied thermo plastic materials with glass reflectorising beads as per relevant clauses of section 803 of M.O.R.T.H specifications.
2. Road marking shall be as per IRC: 35-1997. This marking shall be applied to road centre lines, edge lines, continuity line, stop lines, give –way lines, diagonal/chevron markings, zebra crossing and at parking areas by means of an approved self propelled machine which has satisfactory cut-off valves capable of applying broken lines automatically.
3. Synthetic enamel paints shall be used to display details of structure number, span arrangement etc. on all culverts and bridges with required description as per M.O.S.T. guidelines.

Specifications of Thermo –Plastic Road Marking

1. All markings should be strictly in accordance with code of practice for road marking, paints IRC-35 and as specified by the engineer-in-charge.
2. The thermoplastic materials shall be homogeneous / composed of aggregate, pigment, resins and glass reflectorizing beads and shall conform to B.S. 3262 PART I/ASTMD36.

3. Requirements:-

- i) Composition- The material shall be free from all skins, dirt and foreign objects.

Sr. No.	Component	White	Yellow
1	Binder	18.0 min	18.0 min
2	Glass beads	20.0 min	20.0 min
3	Titanium Dioxide	10.0 min	

- ii) Properties: -

The properties of thermoplastic material, when tested in accordance with A.S.T.M.D. 36/BS-3262 (Part I) shall be as below:

- a) Luminance :-

White day light- Luminance at 45⁰- 65 % min as per AASHTO M 249
Yellow day light- Luminance at 45⁰- 45 % as per AASHTO M 249.

- b) Drying time-

When applied at a temperature specified by the manufacturer and to the required thickness, the material shall set to beat traffic is not more than 15 min.

- c) Skid resistance – not less than 45 as per BS-6044.

- d) Cracking resistance at low temperature-

The material shall show no cracks on application to concrete blocks.

- e) Softening point- 102.5 as per & 9.5 c as per ASTM D 36

- f) Flow resistance – Not more than 25% per AASHTO M249.

- g) Yellowness index (for white thermoplastic paint) Not more than one as per AASHTO M249.

4. Reflectorisation shall be achieved by incorporation of beads. The grading and other properties of the beads shall be as under.

5. The thermoplastic material shall readily get screeded / extruded at temperature specified by the manufacturers for respective method of application to produce a line of specified thickness which shall be continuous and uniform in shape having clear and sharp edges.
6. The subject material upto heating to application temperature shall not exclude fumes, which are toxic, obnoxious or injurious to persons or property.
7. Properties of finished road marking shall be as under:
 - a. The strip shall not be slippery when wet.
 - b. After application and proper drying the strip shall not show appreciable deformation or discolouration under traffic.
 - c. The marking shall not deteriorate by contact with sodium chloride or oil drippings from traffic.
 - d. The strip or marking shall maintain its original dimensions in position. Cold ductility of the material shall be such as to permit normal movement with the road surface without chopping or cracking.
 - e. The colour of yellow marking shall conform to IS Code No. 356 as given in IS 164.
 - f. Durability – The road markings shall be highly durable in all weather and traffic conditions. It shall last for a period of five years. The markings when tested shall show no sign of cracking, flaking, peeling off or disintegration.
8. The marking shall be done by machine.
9. The thermoplastic material shall be applied hot either by screeding of extrusion machine at a temperature within the range specified by the manufacturer.
10. The surface shall be thoroughly cleaned of all dust, dirt, grease, oil and all other foreign matter before application of the paint.
11. The paint shall be applied in intermittent or continuous lines as directed and specified and of uniform thickness of at least 2.5 mm, unless specified otherwise.
12. Where arrows or letters are to be provided, the paint may be hand applied.
13. The tenderer shall furnish a copy of certified test reports from the manufacturer of glass beads obtained from a reputed laboratory showing results of all the tests of all the tests specified and shall certify that the material meets all the requirements of specifications.
14. The thermoplastic material used should be complying to specifications of B.S. 3262 Part –I/ASTMD-36.

37 SPECIAL CONDITIONS FOR MAINTENANCE WORK :-

Rate quoted by the Tenderer against Carrying out Maintenance of Model road for the tenure of 3 (three) years shall include Following works. ...

1. Contractor shall have number of restoration of any part of Road/ footpath/lawn etc. excavated by the agencies like MSEB, MTNL, MGL,Water supply, Sewerage , Electrical or other telephone agencies like Reliance,Vodafone,TATA other Service provider for emergency or repair/ corrections in their service purpose in following manner within 24 hours.
 - a) Remove all excavated / loose material
 - b) Metalling and Laying PCC in M-20 grade concrete.
 - c) Curing the restored part
 - d) Removing all debris and clean this patch.

Contractor will be paid EXTRA for Restoration of any part of Road/ footpath/lawn etc for Laying of New Services only. The Extra payment will be made as actual and as per the current PWD DSR applicable at the time of work executed .

2. Kerb stone,water table,divider / M.S Grills brocken/damaged due to accident or any other reason shall be replaced/repared within 24 hour.
3. Damaged/Broken/Stolen covers of Footpath / sewerage/ MTNL etc. and M.S Grills should be replaced within 24 hour.
4. Kerb stone ,divider , M.S Grills shall be cleaned with water and jute once in month and Kerb stone, Divider, M.S Grills and Tree shall be painted every after 3 months or as directed.
5. Applying lane marking once in year or as directed if fainted.
6. Keeping side drain holes cleaned and keeping Gutter/ Chamber cleaned well before mansoon and during mansoon so as to avoid choke-up.
7. Cleaning of Bio-toilet regularly and keep odour-free.
8. Keeping green corridor all time green by regular watering cleaning, manuring, trimming,and replacing dead shrubs/lawn immediately.If drip irrigation system fails due to any reason, watering should be done by tanker.Any repairs/replacement need for waterpump/drip irrigation equipment should be made repaired/repalced immediately.No Extra payment for any replacement/ repair will be made.
9. Repair / replacement of any steet light/ foot path light / spot light and poles/ brackets/ D. P. box etc. shall be replaced/repaid as and when needed within 24 hours.

Signature of Contractor

No. of Corrections

City Engineer
TMC, Thane

- 10 Painting to Street Light Poles / panels (Except PU coated poles) shall be made once in year and cleaning shall be mnade as directed.
- 11 Debris on road shall be removed and transported within 24 hours.
- 12 Repair and maintenance of Stack elevated parking shall be the responsibilty of contractor. Deployment of skilled operator for maintaining the same shall also be made. Any accidents /damages to users/ operator in this regards will be the responsibilty of Contractor.
- 13 Cleaning of Gantry and all Sign boards shall be carry out regularly.
- 14 Removing / cleaning posters of D.P box/ MTNL box and painting periodically as and when required.
- 15 Any other works necessary for good condition of road as directed by engineer-in-charge.

38 PENALTY FOR NON PERFORMANCE IN MAINTENANCE WORK :-

1. Contractor shall carry out any damages/ discripancies immediately on its own. Department may issue Memo/ Notice for the same and if not attented then, Penalty for an amount of Rs. 1000/- per day will be imposed for non performance of any or all above works individually.
2. Contractor shall keep one maintenance squad for above work. This squad will be of minimum 1no Gardener,1 electrician, 1 civil supervisor, 1 house keeper for Bio-toilet and sufficient labours alongwith Squad-leader.
3. Uniform to All working maintenance staff shall be provided and shall be paid as per Minimum wages Act.If not paid, same will be paid by corporation and will be deducted from any payment payable to contractor.
4. Muster for the Maintenance staff shall be kept and maintained. If sufficient staff not found , then it will be liberty to corporation to impose penalty @ Rs.1000/- per week per person.

39. Electrical works

- 1 On receipt of work order contractor will obtain approval of City Engineer for the make of the material to be used for the work. The contractor will arrange for testing of the material to be utilized for the work. The Contractor shall arrange for testing of material such as pole, cable, fixtures etc. The street pole & cable shall be tested at manufacturing premises in the presence of TMC representative. The LED fixtures shall be tested in NABL accredited laboratory accredited for testing of LED fixtures. All necessary incidental charges shall be borne by the contractor towards testing and arrangement as mentioned above. All the incidental charges toward the same shall be borne by the contractor.
- 2 The material used for the work shall be new & of best quality available and work

Signature of Contractor

No. of Corrections

City Engineer
TMC, Thane

should be carried out with best workmanship. Material used and works carried out shall conform to the relevant Electricity Act & rule of Bureau of Indian standard. Also the work should meet the requirement of local power supply authority MSEDCL.

- 3 The manpower deployed as the contractor shall be adequately qualified and experienced for carrying out the work.
- 4 No tools rollers and tackles ladders will be provided for laying, winding, unwinding of cable by the corporation. Tools such as crowbars, Ghamelas, Phawdas, Ladders etc. will have to be arranged by the contractor for laboures or carrying out work of excavation laying refilling of L.T. cables, erecting of fittings, junction box, Poles etc. loading and unloading of materials head loading of poles. The category wise tools/kits etc. will have to be arranged by contractor.
- 5 Contractor will be solely responsible for the safety of their labours/ employee including payments of compassion in case of accidents/misshapes etc. and also safety of public during the course of work.
- 6 Cable jointing materials, Bricks/tiles/pipes and vehicle for transport of materials from stores centers of TMC, Thane to various works sites will be arranged by the contractor. Loading of materials at above stores and unloading of materials at site will be done by the contractor. i.e. from stores center to site and vice-a-versa at their cost.
- 7 The work carried out should be to the entire satisfaction of the engineer in charge and payments will be made after issue of certificate to that effect by the concerned officer.
- 8 Contractor will be responsible for any damage cost to other installation during the course of work.
- 9 All the rules pertaining to the traffic for safety of public should be taken care by contractor which may include fencing and providing caution notice board and red lamps etc. wherever and whenever required.
- 10 Area of operation of this contract is within the area of Thane Municipal Corporation.
- 11 The Contractor should provide appropriate tools and equipment's to the workmen and ensures that those are in proper working condition and the workmen use the appropriate tools and take precautions
- 12 "PLEASE NOTE THAT ANY ACCIDENT TO THE WORKMEN /PUBLIC/ANIMALS/PROPERTY BOTH MOVABLE AND IMMOVABLE WILL BE THE ENTIRE AND SOLE RESPONSIBILITY OF THE CONTRACTOR AND ANY PROCEEDINGS ARRISING OUT OF THE SAME WILL BE AT THE CONTRACTORS RISK AND COST. THE CORPORATION OR ITS EMPLOYEES WILL NOT BE RESPONSIBLE FOR ANY SUCH INCIDENT."
- 13 Any dismantled material either New or Old should be transported to the required destination at contractor's cost & no other payments will be made to the contractor for the same. The contractor have to submit receipt of dismantled material handed Over to storekeeper along with the bills. The final bills will not be processed without the same.

- 14 The Contractor should monitor the electrical load on each phase & each circuit in the panel & also maintain load balance equally on all the phases. He should never allow any circuit to be overloaded.
- 15 The contractor should maintain field dairy as per the format suggested by Engineer-in-charge & should make entries every day during the course of progress of work.
- 16 In case of any doubt regarding technical specifications terms, conditions etc. tenderer can seek clarifications from Executive Engineer on any working day before submission of tender.
- 17 The list of approved makes for electrical material is as annexed in annexure II. The materials required to be used for this work shall be from this list only. If the contractor uses the material other than the approved list, the same shall be got approved City Engineer TMC Thane. The LED fixtures of makes other than above approved makes, meeting all technical & lighting parameters may be approved after testing of fixtures in NABL accredited laboratory accredited for testing of LED.

40. INCOME FROM PAY and PARK

- 1 Contractor is allowed to collect money through Pay and Parking of vehicles throughout the tenure of 3 years as per approved rates by General body of TMC resolution no 122 dt 8.9.2015 and also allowed to recover penalty on No parking area as per General body of TMC resolution.
2. Parking slots are indicated in the tender document and Schedule of approximate parking density is attached.
3. Contractor may raise all required manpower, machinery like Jammer, Billing machine, towing vehicle etc at his own for collecting Parking Charges.
4. Parking slots and approximate parking density is tentative. Number and size of slots and density of vehicle may vary (less or more). Before quoting for rebate, contractor himself ensure actual availability. No claims in this regard will be entertained forever.

41. PROFESSIONAL FEE OF LANDSCAPE ARCHITECT :-

Thane Municipal corporation will nominate "Landscape Architect" for Landscape design, Selection of material, execution of Landscape work for effective beautification. Successful contractor shall have to follow his instructions and perform accordingly. The Professional Fee @ 1% towards landscape works and decorative works recorded as per award of work will have to be made by successful contractor to such Landscape Architect immediately after issuing such bills by Thane Municipal corporation.

42. *Contractor shall quote for all 3 parts of tender collectively. Part- A consist of ConstructionWorks to be carried out . Part-B consist of Maintenance of road for the tenure of 3 years and Part-C consist of Collection of Money through Parking. Contractor/s has to quote his offer in % (percentage) rate for Part-A , Lumsum Amount for Part –B and Rebate against parking in Part-C.*

Signature of Contractor

No. of Corrections

City Engineer
TMC, Thane

Chapter – V

General Description of work

Signature of Contractor

No. of Corrections

City Engineer
TMC, Thane

CHAPTER - V
DESCRIPTION OF WORKS

1. The scope of work covered under the present tender is resurfacing of existing road , renovation of footpath by modern cement tiling work , preparing lawn and providing shrubs along the road length ,Erection of modern street light ,and footpath light poles ,Providing modern amenities , and beautification of road.

2. **LOCATION ETC.**

The work is situated within Thane Municipal Corporation Limit Kolshet road (From kapurbavdi naka to Airforce station).It should be borne in mind that the details given in paras 1 to 11 below are broad details to get some idea about the type of workinvolved in the work and general site conditions. For more details regarding levels,grades, cross-sections, specifications, mode of construction, quantum of work etc., please refer various cross sections attached to the tender documents, itemwise specifications, Schedule-B and other documents in the contract. The contractors are deemed to have inspected and studied, the site condition regarding the work already done, fresh work to be done,and other structures, and other site and traffic condition etc. before quoting his rate for the work. In case of any variations in respect of technical details, the details given in Schedule- B, itemwise specifications and other specifications and conditions given in the contract shall govern. In respect of details given in regarding site condition, the department does not claim that these details are fully correct and exhaustive.The Contractor should verify the site conditions and be thoroughly conversant with all site conditions/details etc. before quoting and no claims on any account due to variations in the informations in the given site conditions etc. will be accepted by the department. The contractors should study and assess these conditions fully before quoting the rates.

3. **TYPES OF WORK :**

- 3.1 **BITUMINOUS BOUND MACADAM:**

To be provided as per specification and as per the final crust design as directed by Engineer in charge.

- 3.2 **DENCE BITUMIN MACADAM:**

To be provided as per specification and as per the final crust design as directed by Engineer in charge.

- 3.3 **WEARING SURFACE FOR CARRIAGE WAY :**

Signature of Contractor

No. of Corrections

City Engineer
TMC, Thane

These shall consist of Asphalted Concrete as per typical cross section and specification attached.

3.4 FOOTPATH :

There shall consist of construction of fixing kerbs, water tables, soiling, p.c.c., treatment of etc. as per typical section & specifications attached.

3.5 DIVIDER :

These shall consist of precast / cast-in-situ concrete dividers as per typical section & specification attached.

3.6 DRAIN WORKS :

These shall consist of plain cement concrete cast in situ road side drains using ready mix concrete covered with R.C.C. slab including chamber covers with frame as per typical section attached.

3.7 GARDENING WORK:-

These consists of Creation of Landscaping ,preparing and mainting lawns and shubry along the road length .

3.8 ELECTRICAL WORK:-

These consists of providing and fixing street light poles along the median and foothpath decorative poles and spot light along the length.

4. SITE CONDITIONS :

The contractors are deemed to have studied the site conditions including the constraints regarding transport. They should also be familiar with availability of suitable materials, constrains on their storage, availability of labour, weather and climatic conditions and are deemed to have estimated their rates accordingly. The information here in above and provided elsewhere is given in good faith by the employer but the contractor shall satisfy himself regarding all aspects of site conditions and no claim shall be entertained on the plea that the information supplied by the Engineer errorneous or insufficient.

5. CONTRACT DRAWINGS :

The Contract drawings provided for tendering purpose are enclosed with this tender Documents and shall be used for reference and guidance only.

Two copies of working drawings, on the basis of which actual execution of the work is to proceed, shall be furnished free of cost to the Contractor by the City Engineer from time to time as per program of execution approved by the City Engineer.

The Contract Drawing will also include any other Drawings which the Engineer may issue from time to time during the currency of the Contract.

The tendered rates/prices for the work shall be deemed to include the cost of preparation, supply and delivery of all necessary drawings, prints, tracings and negatives which the Contractor is required to provide in accordance with the Contract. No examination or approval by the “Engineer” of any drawing or other documents submitted by the Contractor shall relieve the Contractor of his responsibilities or liabilities under the Contract.

6. The works specified under this contract shall include all general works preparatory to the construction of roads, drainage work and all other things, requisites and work of any kind necessary for the due and satisfactory construction, completion and maintenance of the works to the intent and meaning of the drawings and the specifications and further drawings and orders that may be issued by the City Engineer from time to time, compliance by the Contractor with all general conditions of Contract, whether specifically mentioned or not in the Clause of this specification. All materials, apparatus, plant, machinery, tools, fuel, water, strutting, timbering and tackle of every description, transport, offices, stores workshop, staff labour and the provision of proper and sufficient protective works, diversion, temporary fencing, lighting and watchmen and safety equipment required for the safety of the public and protection of the works at all stages and after completion of work upto the end of guarantee period and adjoining land, first aid equipment, sanitary arrangement for the staff and workmen, the effecting and maintenance of all insurances, the payment of wages, salaries, fees, royalties, duties, taxes, levies or the other charges arising out of the execution of the works and the regular clearance of rubbish, reinstatement and clearing up and leaving perfect of completion. The contractors shall pay the environmental cess on murum and rubble levied by the competent authorities. The contractors shall also pay the royalties as directed by the competent authorities.

TECHNICAL SPECIFICATIONS :

7. GENERAL GUIDELINES FOR TECHNICAL SPECIFICATIONS :

The specifications for various items to be followed are as per M.O.R.T.H 5th revision April 2013 specification for Road and Bridge Works Latest Revision and “ Maharashtra P.W.D. Standard Specification”

In the absence of any definite provisions on any particular item in the aforesaid specifications, and additional specifications given herein after, referenced may be

made to latest I.R.C. Codes of practice, B.I.S. specification and Indian Railway Codes in that order. Where even these are silent the construction and completion of the items shall conform to the Sound Engineering practice and in case of dispute arising out of the interpretation of the above, the decision of the City Engineer shall be final and binding on the Contractors. In brief the order in which the specifications of the work are to be followed shall be as follow.

- (1) M.O.R.T.H 5th revision April 2013 specification for Road and Bridge Works Latest Revision
- (2) Maharashtra P.W.D. Standard Specifications.
- (3) Indian Roads Congress specifications/guidelines.
- (4) Bureau of Indian Standards specifications.
- (5) Indian Railway Standard.
- (6) Sound Engineering Practice.

The abbreviations I.R.C., M.O.R.T.H.5th Revision April 2013., B.I.S. shall be considered to have the following meaning -

- (1) M.O.R.T.H. - Ministry of Road Transport & Highway
- (2) I.R.C. - Indian Road Congress.
- (3) B.I.S. - Bureau of Indian Standards.

The codes of practice, standards and specification applicable shall be those existing as on one month prior to the last date for submission of tender.

In so far as any stipulations made herein conflict or are inconsistent with any of the provisions of M.O.R.T.H. Specifications, Maharashtra P.W.D. Standard Specifications (Red Book), I.R.C. Codes of practice, the Stipulation made herein shall prevail.

8. Providing of site office for supervisory staff of Department of TMC and Quality Control :

The contractor shall have to make arrangement for providing accommodation for office for the P.W. Departmental staff and laboratory for quality control etc. as stated in Clause no. 2.15, Chapter no. IV of this tender documents.

The contractor shall also provide following instrument in 2 sets for TMC staff for each road site.

- | | | | | |
|------|----------------|---|--------------------------|-------------|
| i) | Measuring tape | - | Freeman make (30 m) | - 2 no. |
| ii) | Steel tape | - | Freeman make (3 m) (5 m) | - 2 no. |
| iii) | Steel Scale | - | 30 cm & 15 cm. | - 1 no each |

Signature of Contractor

No. of Corrections

City Engineer
TMC, Thane

- iv) Camber plate - Alluminium camber plate
- v) Thermometer - Digital (portable) with steel probe – 1 no.
capacity min. -50 to max. 2000C.
- vi) Stationery - as required for work.

9. SUSPENSION OF WORKS :

The Contractor shall, on the written order of the City Engineer, suspend the progress of the works of any part thereof for such time or times and in such manner as the City Engineer may consider necessary and shall during such suspension properly protect and secure the work, so far as it is necessary in the opinion of the City Engineer.

If the suspension in sub-clause is ordered for no fault of the Contractors, the Contractor shall be entitled to a reasonable extension of time.

10. DEFECT LIABILITY :(Default Guarantee)

Defect liability period for the work shall be **3 years**. This period will be counted from the date of substantial completion of work.

- i) During contract period if any defects occurred, contractor will have to redo the same at his own cost. If contractor does not redo the work, the amount of redoing the work with 15% establishment cost of it will be recovered from the contractor's bills.
- ii) During defect liability period if any defect noticed, contractor will have to rectify the same at his own cost. If contractor does not redo the work, the amount of redoing the work with 15% establishment cost of it will be recovered from bank guarantee submitted by contractor or from security deposit recovered from bills.

11. EXCAVATION & TRENCHING :

All trenches 1.5 meters or more in depth shall height all times be supplied with at least one ladder for each 30 meters in length or fraction thereof. Ladder shall be extended from bottom of trench to at least one meter above surface of the ground. Sides of a trench which is 1.5 meters or more in depth shall be stepped back to give suitable slope, or Security held by timber bracing, so as to avoid the danger of sides collapsing, excavated materials shall not be placed with 1.5 meters of edge of trench or half of depth of trench whichever is more. Cutting shall be done from top of bottom. Under no circumstance, shall undermining or undercutting, be done.

Signature of Contractor

No. of Corrections

City Engineer
TMC, Thane

12. SUB-LETTING OF WORK :

The Contractor shall not be permitted to sub-let any of the work.

13. CERTIFICATION OF SUBSTANTIAL COMPLETION WORKS:

On completion and taking over of works or apart of works exclusively stipulated in the contract documents, all in the accordance with the terms of contract agreement and further subject to the condition that the completed works or items of works, as the may be (In case of phase completion) the City Engineer will issue a substantial completion certificate for whole or part of the works as the case may be on receiving written request from the contractor. The substantial Completion is defined as stage of the work when it has been completed and made ready for functional use, although some minor points or insignificant items of work still remain to be completed, however this minor points and insignificant items should not have any bearing on the functionality of the item. Provided always that the said substantial certificate being issued, prior to completion of whole of the works shall not be deem to prompt requirement of reinstatement of any ground or surface, as may be necessary under contract provisions.

The completion certificate shall be issued by the City Engineer after completion of all minors works mentioned in substantial completion of works.

14. No Demand Certificate :-

This certificate is to be submitted along with the final bill as per format annexed.

15. No Claim Certificate for labour :-

This certificate is to be submitted along with the final bill as per format annexed.

16. Protection of utility services :-

Tenderer has to take care of all utility services. If the services are damaged, they are to be rectified by the tenderer at his own cost. Concern agencies will divert the service. Ducts are provided for services at regular intervals.

Chapter – VI

FORMATS

- 1) **Bank Guarantee for Security Deposit.**
- 2) **Form of Agreement**
- 3) **No Demand Certificate**
- 4) **No Claim Certificate for Labour**
- 5) **Joint Venture Form of Agreement**

Form –1

(The Contractor shall make the agreement on a stamp paper of the following amount)

1. Rs100 - For first Rs 25,000/- (Rupees Twenty Five Thousand)
 2. Additional Rs 5/- per Rs 1000/- for remaining amount of Security Deposit amount
- OR

(The amount which the government of Maharashtra amends from time to time.)

Bank Guarantee for Security Deposit

In consideration of the Thane Municipal Corporation Thane (herein after called “TMC Thane”) having agreed to exempt (Name of Contractor) _____ (herein after referred to as “the Contractor”) from depositing with the TMC Thane in cash of the sum of Rs. _____ (Rupees _____ only) being the amount of security deposit payable by the Contractor or to the TMC Thane for the work (Name of work _____) under the terms and conditions of an agreement dated the _____ day _____ of _____ and _____ made between the TMC Thane of the one part and the Contractor of the other part (here in referred to as "the said Agreement") for _____ as security for the due observance and performance by the Contractor of the terms and conditions of the said Agreement, on the contract furnishing to the TMC Thane a guarantee in to the prescribed form of a Scheduled Bank in India being in fact those present in the like sum of Rs. _____ (Rupees _____ only). We _____ BANK/LIMITED registered in India under _____ Act and having one of our local Head Office at _____ do hereby :

- 1) Guarantee to the TMC Thane.
 - (a) Due performance and observance by the Contractor of the terms, covenants and conditions on the part of the Contractor contained in the said Agreement and
 - (b) Due and punctual payment by the Contractor to the TMC Thane of all sums of money, losses, damages, cost charges, penalties and expenses payable to the TMC Thane by the Contractor under or in respect to the said agreement.
- 2) Undertake to pay the TMC Thane on demand and without demand and not withstanding any dispute or disputes raised by the Contractor(s) in any suit or proceeding filed in any Court of tribunal relating there to the said sum of Rs. _____ (Rupees _____ only) or such less sum may be demanded by the TMC Thane from us our liability hereunder being absolute and unequivocal and agree that.

Signature of Contractor

No. of Corrections

City Engineer
TMC, Thane

- 3) (a) The guarantee herein contained shall remain in full force & effect during the subsistence of the said agreement and the same will continue to be enforceable till all the dues of the TMC Thane under or by virtue of the said agreement have been duly paid and its claims satisfied or discharged and till the TMC Thane certifies that the terms and conditions of the said agreement have been fully and properly carried out by the Contractor.
- (b) We shall not be discharged or released from the liability under this guarantee by reasons of
- (i) Any change in the constitution of the bank of the Contractor, or
 - (ii) Any arrangement entered in between the TMC Thane and the Contractor with or without our consent;
 - (iii) Any forbearance or indulgence shown to the Contractor;
 - (iv) Any variation in terms of covenants or conditions contained in the said agreement;
 - (v) Any time given to the Contractor;
 - (vi) Any other conditions or circumstances under which, in law, a surety would be discharged;
- (c) Our liability here under shall be joint and several with that of the Contractor as if we were the principal debtors in respect of the said sum of Rs. _____ (Rupees _____ only) and _____ only) and
- (d) We shall not revoke this guarantee during its currency except with the previous consent in writing of the TMC Thane.
- (e) Notwithstanding anything contained herein above
- i) Our liability under this bank guarantee shall not exceed of Rs(In word). This Bank Guarantee shall be valid upto (Defect Liability Period) and
 - ii) We are liable to pay the guaranteed amount or any part thereof under this Bank Guarantee only and only if, you serve upon us a written claim or demand on or before (Defect Liability Period)
- (IN WITNESS WHERE OF THE common seal of _____ has been herein to affixed this _____ day of _____ 200_____. The common seal of _____ was pursuant to the resolution of the Board of Directors of the Company dated the _____ day of _____ herein affixed in the presence of _____ who, in token thereof, have here to set their respective hands.

Signature of Contractor

No. of Corrections

City Engineer
TMC, Thane

Form – 2

(The Contractor shall make the agreement on a stamp paper of the following amount)

1. Rs500 - For first 10 Lakhs
- 2 For remaining amount of contract value – additional 0.1%
- 3 Upward sealing is Rs 25.0 lakhs

OR

The amount which the government of Maharashtra amends from time to time.

FORM OF AGREEMENT

THIS AGREEMENT is made on the _____ day of 2016 between Thane Municipal Coporation, Thane hereinafter called "the Employer" of the One Part and _____ (Name of Tenderer _____) _____ (Mailing address of Contractor) "the Contractor" of the other part.

WHEREAS the Employer is desirous that certain works should be executed viz., (Name of the contract.....) and has accepted a Tender by the Contractor for the execution, completion and guarantee of such works NOW THIS AGREEMENT WITNESSETH as follows :

The cost of this work is Rs(In word Rs.....)

1. In this Agreement words and expression shall have the same meaning as are respectively assigned to them in the Conditions of Contract hereinafter referred to.
2. The following documents shall be deemed to form and be read and construed as part of this Agreement, viz.,
 - a) All tender Documents as issued by the Employer for this work.
 - b) All amendments to the tender documents as issued by the Employer prior to submission of the bids.
 - c) Acceptance letter issued by the Employer vide No. _____ and all correspondence exchanged between the Employer and the Contractor upto the date of issue of acceptance letter as specifically referred to in the said acceptance letter.
3. In consideration of the payment to be made by the Employer to the Contractor as hereinafter mentioned, the Contractor hereby covenants with the Employer to

Signature of Contractor

No. of Corrections

City Engineer
TMC, Thane

execute and complete the works in conformity in all respects with the provisions of the contract.

- 4. The Employer hereby covenants to pay the Contractor in consideration of the execution, completion, of the Works the contract price at the times and in the manner prescribed by the Contract.

IN WITNESS WHEREOF the parties hereto have caused their respective Common Seals to be hereunto affixed (or have hereunto set their respective hands and seals) the day and year first above written.

SIGNED, SEALED AND DELIVERED

By the said

By the said

Name _____

Name _____

on behalf of **the Contractor**

on behalf of the Employer

in the presence of :

in the presence of :

Name _____

Name _____

Address _____

Address _____

Form No. 3
No Demand Certificate
On Contractor's Letterhead

To,
 City Engineer,
 Thane Municipal Corporation, Thane.
 Adv. Almeida Road, Panchpakhadi,
 Thane.

Date : _____

Subject :- (Name of work)

NO DEMAND CERTIFICATE

This is to certify as under

We hereby confirm and assure in writing that we have no claim/demand of any amount from Thane Municipal Corporation in respect of the above said work which was awarded on us vide work order No. _____ dated _____.

We indemnify Thane Municipal Corporation against any claim/demand. Any matter arise in future in respect of this contract from either our supplier, sub contractors or labours who have contributed their services directly/indirectly for this contract.

Authorised Signatory

(_____Name_____)

For _____Name of the Agency_____

Signature of Contractor

No. of Corrections

City Engineer
 TMC, Thane

Form No. 4
No Claim Certificate for Labour
On Contractor's Letterhead

To,
 City Engineer,
 Thane Municipal Corporation, Thane.
 Adv. Almeida Road, Panchpakhadi,
 Thane.

Subject :- (Name of work)

NO CLAIM CERTIFICATE FOR LABOUR

This is to certify as under

We hereby confirm that we have paid all the wages to all the labours employed under this contract as per minimum Wages declared by the Govt. of Maharashtra.

In case in future any claim arised inadvertantly shall be dealt by us as we understood that this is our sole responsibility.

We indemnify Thane Municipal Corporation against any claim arised in future in respect of this contract from any labour deployed by us on the works under this contract.

Authorised Signatory

(_____ Name _____)

For _____ Name of the Agency _____

Signature of Contractor

No. of Corrections

City Engineer
 TMC, Thane

Form - 5
JOINT VENTURE FORM OF AGREEMENT

This Joint Venture agreement is made on the _____ day of 2016 between

and _____

JOINTLY agree to carry out the work _____

if the Contract is awarded to us the (Brief description of division of works, required be carried out) _____

who _____ of this tender duly _____ we nominate

_____ as

authorised nominee/signatory to execute the work and accept the joint responsibility with " _____ "

which is being represented by _____

of the _____

both of them are authorised by their respective companies to act on behalf of the company and the company is fully responsible for any act done for discharge of his duties for completion of the work during the contract time period, if the job is awarded. We put our companies seals with signatures of authorised persons below and accept the responsibility jointly and severally to carry out the contract, if awarded.

SIGNED, SEALED AND DELIVERED

SIGNED, SEALED AND DELIVERED

by the with named _____

by the with named _____

_____ through its duly

_____ through its duly

constituted Attorney _____ constituted Attorney _____

_____ in the presence of _____ in the presence of

Chapter – VII

Declaration of Contractor

Signature of Contractor

No. of Corrections

City Engineer
TMC, Thane

CHAPTER VII

DECLARATION OF THE CONTRACTOR

I/We, hereby declare that, I/We have made myself/ourself thoroughly conversant with Site condition, local conditions and availability of materials (such as stone, murum, sand. source of water, etc.) and Labour and on ensuring above, I/We have quoted my/our rates of this work. The specifications, conditions/ special conditions and lead of materials on this work have been carefully studied and understood by me/us before submitting this tender. I/We undertake to use only the best materials approved by the City Engineer, Thane Municipal Corporation, Thane of his duly authorised assistant before starting the work and to abide by his decision.

I/We have gone through all General conditions of contract, Special conditions of contract & Clause no.37 and 38 of Special conditions of contract of the Tender document carefully.

Seal & Signature of Contractor(s).

Signature of Contractor

No. of Corrections

City Engineer
TMC, Thane

Chapter – VIII

**Agreement B-1
Tender Form**

Signature of Contractor

No. of Corrections

City Engineer
TMC, Thane

CHAPTER - VIII

TENDER FOR WORKS

1. I/We hereby tender for the execution for the Thane Municipal Corporation, Thane (hereinbefore and hereinafter referred to as 'TMC, Thane') of the work specified in the memorandum within the time specified as below in accordance with all respects with the specifications, designs, drawings and instructions in writing alongwith conditions of contract.

Scope of work	Estimated Cost	Rate quoted @	Amount as per rate quoted
Part A- Improvement of Kolshet road (From kapurbavdi naka to Airforce station) as Model Road by Renovation and Beautification of Existing Road.	Rs14,33,11,000/- (As per Schedule – B attached)% above /below the Estimated Cost	Rs.
Part B- Maintenance of Kolshet road (From kapurbavdi naka to Airforce station) for the period of 3 years.		Lumsum Amount	Rs.
Part C- Collection of Parking charges (all types of vehicles collectively)		Rebate	Rs.

2. I/We agree that this offer shall remain open for acceptance for a minimum period of 180 days from the date of opening the same and thereafter until it is withdrawn by me/us by notice in writing duly addressed to the authority opening the tenders and sent by registered post A.D. or otherwise delivered, at the office of such authority. The amount of Earnest Money shall not bear interest and shall be liable to be forfeited to the TMC, Thane if I/We fail to (i) abide by the stipulation to keep the offer open for the period mentioned above or (ii) sign and complete the contract documents as required by the City Engineer and furnish the security deposit as specified in and within the time limit, laid down in conditions of the contract. The

Signature of Contractor

No. of Corrections

City Engineer
TMC, Thane

amount of earnest money may be adjusted towards the security deposit or refunded to me/us if so desired by me/us in writing unless the same or any part thereof has been forfeited as aforesaid.

- 3. Should this tender be accepted, I/We hereby agree to abide by and fulfill all the terms and provisions of the conditions of contract annexed hereto so far as applicable and in default thereof to forfeit and pay to TMC, Thane the sum of money mentioned in the said condition.

Contractor _____
 Name & Address _____

Dated _____ day of _____ 2016 _____

(Witness) _____
 Name & Address _____
 Occupation _____

The above tender is hereby accepted by me for and on behalf of the Thane Municipal Corporation.

Officer _____
 Dated _____ day of _____ 2016 _____

City Engineer
Thane Municipal Corporation, Thane.

CONDITIONS OF CONTRACT

CLAUSE 1

The person/persons whose tenders may accepted (hereinafter called the Contractor, which expression shall unless excluded by or repugnant to the context include his heirs, executor, administrators and assigns) shall (A) within 10 days (which may be extended by the City Engineer concerned upto 15 days' if the City Engineer thinks fit to do so) of the receipt by him of the notification of acceptance of his tender deposit with the City Engineer in cash or approved securities endorsed to the Commissioner of sum sufficient which will make up the full security deposit specified in the tender and (i) above and (B) Permit TMC, Thane at the time of making any payment to him for work done under the contract to deduct such as will amount to Five(5%) percent. Of all money so payable such deductions to be held by TMC, Thane by way of security deposit until the full amount of the security deposit is made up. All compensation or other money payable, by the Contractor to TMC, Thane under the terms of his contract may be deducted from or paid by the sale of sufficient part of his security deposit or from the interest arising therefrom or from any sums which may be due or may become due by TMC, Thane to the contractor under any other contract or transaction of any nature on any account whatsoever and in the event of his security deposit being reduced by reason of any such deduction or sale as aforesaid the contractor shall, within ten days thereafter, make good in cash or approved securities endorsed any sum or sums which may have been deducted from or raised by sale of his security deposit or any part thereof. The security deposit referred to when paid in cash may, at the cost of the depositor, be converted into interest bearing securities.

If the amount of securities deposit to be paid in lump-sum within the period specified at (A) above is not paid the tender/contract already accepted shall be considered as cancelled and legal steps taken against the contractor for recovery of the amounts. The amount of security deposit retained by the TMC, Thane shall be released after the expiry of period upto which the contractor has agreed to maintain the work in good order is over. In the event of the contractor failing or neglecting to complete rectification work within the period upto which the contractor has agreed to maintain the work in good order, then subject to provisions of clauses 17 and 20 hereof the amount of

Signature of Contractor

No. of Corrections

City Engineer
TMC, Thane

security deposit returned, by TMC, Thane shall be adjusted towards excess cost incurred by the TMC, Thane on rectification work.

CLAUSE 2

The time allowed for carrying out the work as entered in the tender shall be strictly observed by the contractor and shall be reckoned from the date on which the order to commence work is given to the contractor.

The work shall through out the stipulated period of the contract be proceeded with,with all due diligence (time being deemed to be the essence of the contract on the part of the contractor) and the contractor shall pay as compensation an amount **equal to one percent or such smaller amount as the City Engineer (whose decision in writing shall be final)** may be decide, of the amount of the estimated cost of the whole work as shown by the tenderer for **every day** that the work remains uncompleted,or unfinished after the proper dates.And further to ensure good progress during execution of work, the contractor shall be bound ,in all cases in which the time allowed for any work exceeds on month to complete.

The contractor should complete the work as per phase period given below.

25% of work in **1/4** of the time

50% of work in **1/2** of the time

75% of work in **3/4** of the time

Full work i.e. **100 %** work will have to be completed in **Eight (8)** calender months **excluding monsoon**.

In the event of the contractor failing to comply with this condition he shall be liable to pay as compensation an amount equal to one percent or such smaller amount as the City Engineer (whose decision in writing shall be final) may decide of the said estimated costof the whole work per daythat the due quantity of the work remains incomplete, provided always that the total amount of the compensation to be paid under provisions of this clause shall not exceed **10%** of the estimated cost of the work shown in the tender.The City Engineer shall be final authority in this respect,irrespective of the fact that the tender is accepted by the Municipal Commissioner/ Standing Committee.

Signature of Contractor

No. of Corrections

City Engineer
TMC, Thane

CLAUSE 3

In the case in which under any laws of this contract the contractor shall have rendered himself liable to pay compensation amounting to the whole of his security deposit (whether paid in one sum or deducted by installments) or in the case of abandonment of the work owing to serious illness or death of the contractor or any other cause, the City Engineer on behalf of the TMC, Thane shall have power to adopt any of the following courses as he may deem best suited to the interest of TMC, Thane.

- a) To rescind the contract for which rescission notice in writing to the contractor under the signature of the City Engineer) shall be conclusive evidence and in that case the security deposit of the contractor shall stand forfeited and be absolutely at the disposal of the TMC, Thane.
- b) To carry out the work or any part of the work departmentally, debiting the contractor with the cost of the work expenditure incurred on tools and plants and charges on additional supervisory staff including the cost of work charged establishment employed for getting the unexecuted part of the work completed and crediting him with the value of the work done departmentally in all respect in the same manner and at the rates as if it has been carried out by the contractor under the terms of his contract. The certificate of the City Engineer as to the cost and other allied expense as incurred and as to the value of the work so done departmentally shall be final and conclusive against the contractor.
- c) Order that the work of the contractor be measured up and to take such part as thereof as shall be unexecuted out of his hands, and to give it to another contractor to complete, in which case all expenses incurred on advertisement for fixing a new contracting agency, additional supervisory staff including the cost of work charged establishment and cost of the work executed by the new contract agency will be debited to the contractor and the value of the work done or executed through the new contractor shall be credited to the contractor in all respects and in the same manner and at the same rates as if it had been carried out by the contractor under the terms of his contract. The certificate of the City Engineer as to all cost of the work and other expenses incurred as aforesaid for, or in getting the unexecuted work

done by the new contractor and as to the value of the work so done shall be final and conclusive against the contractor.

In case the contract shall be rescinded under clause (a) above the contractor shall not be entitled to recover or be paid any sum for any work therefore actually performed by him under this contract unless and until the City Engineer shall have certified in writing performance of such work and the amount payable to him in respect thereof and he shall only be entitled to be paid the amount so certified. In the event of either of the course referred to in clause (b) or (c) being adopted and the cost of work executed departmentally or through a new contractor and other allied expenses exceeding the value of such work credited to the contractors, the amount of excess values shall be deducted from any money due to the contractor by the TMC, Thane under the contract or otherwise howsoever or from his security deposit or the sale proceeds thereof, provided however that the contractor shall have no claim against TMC, Thane even if the certified value of the work done departmentally or through a new contractor exceeds the certified cost of such work and allied expenses provided always that whichever of the three Courses mentioned in clauses (a), (b) or (c) is adopted by the City Engineer, the contractor shall have ii,) claim to compensation for any loss Sustained by him by reason of his having purchased, or procured any material or entered into engagements or made any advances on account or with a view of the execution of the work or the performance of the contract. The certificates of the City Engineer as to all cost of the work and other expenses incurred as aforesaid for or in getting the unexecuted work done by the new contractor and as to the value of the work so done and shall be final and conclusive against the contractor.

CLAUSE 4

If the progress of any particular portion of the work is unsatisfactory the City Engineer shall notwithstanding that the general progress of the work is satisfactory in accordance with clause (2) be entitled to take action under clause 3 (b) after giving the contractor 10 days notice in writing and the contractor will have no claim for compensation, for any loss sustained by him owing to such action.

CLAUSE 5

In any case in which any of the power conferred upon the City Engineer by clauses 3 and 4 hereof 'shall have become exercisable and the same shall not have been exercised, non-exercise thereof shall

Signature of Contractor

No. of Corrections

City Engineer
TMC, Thane

not constitute a waiver of any of conditions thereof and such powers shall notwithstanding be exercised in the event of any future case of default by the contractor, for which, by any clause or clauses hereof he is declared liable to pay compensation amounting to the whole of his security deposit and the liability of the contractor for past and future compensation shall remain unaffected.

In the event of the City Engineer taking the action under sub clauses (a) or (c) of clause 3 he may if he so desires, take possession of all or any tools, plants materials and stores in or upon the works or the site thereof or belonging to the contractor or procured by him and intended to be used for the execution of the work or any part thereof, paying or allowing for the same in account at the contract rates, or in the case of contract rates not being applicable at current market rates to be certified by the City Engineer whose certificate thereof shall be final. In the alternative the City Engineer may after giving notice in writing to the contractor alternative the City Engineer may after giving notice in writing to the contractor or his clerk of the work, foreman or other authorised agent, require him to remove such tools, plants, materials, or stores from the premises within a time to be specified in such notice, and in the event of the contractor failing to comply with any such requirement the City Engineer may remove them at the contractor's expense or sell them by auction or private sale at risk and account of the contractor in all respects and the certificate of the City Engineer, as to the expense of any such removal, and the amount of the proceeds, and expense of any such sale shall be final and conclusive against the contractor.

CLAUSE 6

If the contractor shall desire an extension of time for completion of the work on the ground of his having been unavoidably hindered in its execution or on any other ground he shall apply in writing to the City Engineer before the expiration of the period stipulated in the tender or before the expiration of 30 days from the date on which he was hindered as aforesaid, or on which the cause for asking for the extension occurred, whichever is earlier and the City Engineer if in his opinion there was reasonable grounds for granting an extension grant such extension if he thinks necessary or proper. The decision of the City Engineer in this matter shall be final.

Signature of Contractor

No. of Corrections

City Engineer
TMC, Thane

occurring of any claim, nor shall it conclude, determine, or affect in any other way the powers of the City Engineer as to the final settlement and adjustment of the account or otherwise, or in any other way vary or affect the contract. The final bill shall be submitted by the contractor within one month of the date fixed for the completion of the work, otherwise City Engineer's certificate of the measurements and of the total amounts payable for the work shall be final and binding on all parties.

CLAUSE 9 The rates for several items on work estimated to cost more than Rs. 10000/- agreed to within, shall be valid only when the item concerned is accepted as having been completed fully in accordance with the sanctioned specifications. In case where the items of work are not accepted as so completed the City Engineer may make payment on account of items at such reduced rates as he may consider reasonable in the preparation of final or on accounts bill.

CLAUSE 10 A bill shall be submitted by the contractor as explained earlier i.e. cost not less than 1/5th cost of tendered amount or as decided by Engineer-in-Charge depending on site situation, on or before the date fixed by the City Engineer for all work executed previously and the City Engineer shall take or cause to be taken requisite measurement for the purpose of having the same verified, and the claim so far as it is admissible, shall be adjusted, within 10 days from the presentation of the bill. If the contractor does not submit the bill within the time fixed as aforesaid, the City Engineer may depute a subordinate to measure the said work in the presence of the contractor or his duly authorised agent whose counter signature to the measurement list shall be sufficient warrant, and the City Engineer may prepare a bill from such list which shall be binding on the contractor in all respects.

CLAUSE 11 The contractor shall submit all bills on the printed forms to be had on application at the office of the City Engineer. The charges to be made in tile bills shall always be entered at the rates specified in the tender or in the case of any extra work ordered in pursuance of these conditions and not mentioned or provided for in the tender, at the rates hereinafter provided for such work.

CLAUSE 12 If the specifications or estimate of the work provided for the use of any special description of materials to be supplied from the TMC, Thane stores or if it is required that the contractor shall use certain

Signature of Contractor

No. of Corrections

City Engineer
TMC, Thane

stores to be provided by the City Engineer (such materials and stores, and the prices to be charged therefore as hereinafter to mention being so far as practicable for the convenience of the contractor but not so as in anyway to control the meaning and effect of this contract-specified in the schedule or memorandum hereto annexed) the contractor shall be supplied with such materials and stores as he may be required from time to time to be used by him for the purpose of the contract only and the value of the full quantity of materials and stores supplied shall be set off or deducted from any "Sums then due or thereafter to become due to the contractor under the contract, or otherwise, or from the security deposits or the proceeds of the sale thereof. If the deposit is held in approved securities, the same or a sufficient portion thereof shall in that case be sold for the purpose. All material supplied to the contractor shall remain the absolute property of TMC, Thane and shall on no account be removed from the site of work, and shall at all times be open to inspection by the City Engineer. Any such materials unused and in perfectly good condition at the time of completion or termination of the contract shall be returned to the TMC Thane store, if the City Engineer so requires by notice in writing given under his hand but the contractor shall not be entitled to return any such material except with such consent of the City Engineer and he shall have no claim for compensation on account of any such material supplied to him as aforesaid but remaining unused by him or for any wastage in or damage to any such materials.

CLAUSE 12(A) All stores of controlled materials such as cement, steel, etc. supplied to the contractor by TMC or procured by the contractor, should be kept by the contractor under lock and key and they will be accessible for inspection by the City Engineer or his authorised agent at all the times.

CLAUSE 13 The contractor shall execute the whole and every part of the work in the most substantial and workman like manner, and both as regards material and in every other respect in strict accordance with specifications. The contractor shall also confirm exactly, fully and faithfully to the designs, drawings and instructions in writing relating to the work signed by the City Engineer and lodged in his office and to which the contractor shall be entitled to have access for the purpose

Signature of Contractor

No. of Corrections

City Engineer
TMC, Thane

of inspections at such office, or in the site of the work during office hours. The contractor will be entitled to receive three sets of contract drawings and working drawings as well as one certified copy of the accepted tender along with the work order free of cost.

CLAUSE 14

The City Engineer shall have power to make any alterations in or additions to the original specification drawings, designs and instructions that may appear to be necessary or advisable during the progress of the work and the contractor shall be bound to carry out the work in accordance with any instructions in this connection which may be given to him in writing signed by the City Engineer and such alteration shall not invalidate the contract, and any additional work which the contractor may be directed to do in the manner above specified as part of the work shall be carried out by the contractor on the same conditions in all respect on which he agreed to do the main work, and at the same rates as per specified in the tender for the main work as stated earlier in Special Condition of Contract. And if the additional and altered work includes any class of work for which no rate is specified in this contract, then such rates will be taken as per Chapter VIII – Clause 38 (6) as extra items.

CLAUSE 15 1)

If at anytime after the execution of the contract documents, the City Engineer shall for reasons whatsoever (other than default on the part of the contractor for which the TMC, Thane is entitled to rescind the contract) desires that the work or any part of the work specified in the tender should be suspended for any period of that the whole or part of the work should not be carried out at all, he shall give to the contractor a notice in writing of such desire and upon receipt of such notice the contractor shall forthwith suspend or stop the work wholly or in part as required, after having due regard to the appropriate stage at which the work should be stopped or suspended so as not to cause any damage or injury to the work already done or endanger the safety thereof provided that the decision of the City Engineer as to the stage at which the work any part of it could be or could have been safely stopped or suspended shall be final and conclusive against the contractor. The contractor shall have no claim to any payment of compensation whatsoever by reason of or in pursuance of any notice as aforesaid on account of any suspension stoppage or curtailment except to the extent specified hereinafter.

- 2) Where the total suspension of work ordered as aforesaid continued for a continuous period exceeding 90 days, the contractor shall be at liberty to withdraw from the contractual obligations under the contract so far as it pertains to the unexecuted part of the work by giving 10 days prior notice in writing to the City Engineer within 30 days of the expiry of the said period of 90 days of such intention requiring the City Engineer to record the final measurement of the work already done and to pay the final bill. Upon giving such a notice the contractor shall be deemed to have been discharged from his obligations to complete the remaining unexecuted work under this contract. On receipt of such notice the City Engineer shall proceed to complete the measurement and make such payments as finally due to the contractor within the period of 90 days from receipt of such notice in respect of the work already done by the contractor, such payment shall not in any manner prejudice the right of the contractor to any further compensation under the remaining provision of this clause.
- 3) Where the City Engineer requires the contractor to suspend the work for the period in excess of 30 days at any time or 60 days in aggregate, the contractor shall be entitled to apply to the City Engineer within 30 days of the resumption of the work after such suspension of payment of compensation to the extent of pecuniary loss suffered by him in respect of working machinery remaining idle on site or on account of his having had to pay the salary or wages of labour engaged by him during the said period of suspension provided always that contractor shall not be entitled to any claim in respect of any such working machinery, salary or wages whatsoever occasioned by unsatisfactory work or any other default on his part. The decision of the City Engineer in this regard shall be final and conclusive against the contractor.
- 4) In the event of :
 - i) Any total stoppage of work on notice from the City Engineer under sub clause (1) in that behalf.
 - ii) Withdrawal by the contractor from the contractual obligations to complete the remaining unexecuted work under sub clause(2) on account of continued suspension of work for a period exceeding (90) days.

- iii) Curtailment in the quantity of item or items originally tendered on account of any alterations omissions or substitution as in the specifications, drawings, designs or instructions under clause 14 (i) where such curtailment exceeds 40% in quantity and the value of the quantity curtailed beyond 40% at the rates for items specified if the tender is more than Rs.5,000\-.

It shall be open to the contractor within (90) days from the service of (i) the notice of stoppage of work or (ii) the notice of withdrawal from the contractual obligations under the contract on account of the continued suspension of the work or (iii) notice under clause 14 (i) resulting in such curtailment to produce to the City Engineer satisfactory documentary evidence that he had purchased or agreed to purchase material to use in the contracted work, before receipt by him of the notice of the stoppage, suspension or curtailment and require the TMC, Thane to take over on payment of such material at the rates determined by the City Engineer, provided however such rates shall in no case exceeds the rates at which the same where acquired by the contractor. The TMC, Thane shall thereafter take over the material so offered provided the quantities offered are not in excess of the requirements of the unexecuted work as specified in the accepted tender and are of quality and specifications approved by the City Engineer.

CLAUSE 15(A)

The contractor shall not be entitled to claim any compensation from the TMC, Thane for the loss suffered by him on account of delay by TMC Thane in the supply of materials entered in schedule “A” where such delay is caused by

- i) Difficulties relating to the supply of railway wagons.
- ii) Force major.
- iii) Act of God.
- iv) Act of enemies of the state or any other reasonable cause beyond control of Thane Municipal Corporation.

In case of such delay in the supply of material, the TMC, Thane shall grant such extension of time for the completion of the work as shall appear to the City Engineer to be reasonable in accordance with the circumstances of the case. The decision of the City Engineer as to the extension of time shall be accepted as final by the contractor.

CLAUSE 16 Under no circumstances what so ever shall be contractor be entitled to any compensation from TMC, Thane on any account unless the contractor shall have submitted a claim in writing to the City Engineer within one month of the case of such claim occurring.

CLAUSE 17 If any time before the security deposit or any part thereof is refunded to the contractor it shall appear, to the City Engineer or his subordinate in charge of the work, that any work has been executed with unsound, imperfect or unskillful workmanship or with materials of inferior quality, or that any materials or articles, provided by him for the execution of the work are unsound or the quality inferior to that contracted for, or are otherwise not in accordance with the contract. It shall be lawful for the City Engineer to intimate this fact in writing, to the contractor and then notwithstanding the fact that the works, materials or articles, complained of may have been inadvertently passed, certified and paid for, the contractor shall be bound forthwith to rectify, or remove and reconstruct the work so specified in whole or in part, as the case may require or if so required shall remove the material or articles so specified and provide other proper and suitable materials or articles at his own charge and cost and in the event of his failing to do so within a period to be specified by the City Engineer in written intimation aforesaid the contractor shall be liable to pay compensation at the rate of 1% on the amount of the estimate for, everyday not exceeding 10 days during which the failure so continues and in the case of any such failure City Engineer may rectify or remove and re-execute the work or remove and replace the materials or articles complained of as the case may be at the risk and expenses in all respects, of the contractor. Should the City Engineer, consider that any such inferior work or materials, as described above maybe accepted or made use of it shall be within his discretion to accept the same at such reduced rates as he may fix therefore.

CLAUSE 18 All works under or course of execution or executed in pursuance of the contract shall at,ill times be open to the inspection and supervision of the City Engineer and his subordinates, and contractor shall at all times during the usual hours and at all other times at which reasonable notice of the intention of the City Engineer or and his subordinate to visit the work shall have been given to the contractor, either himself

Signature of Contractor

No. of Corrections

City Engineer
TMC, Thane

be present to receive orders and instructions, or have a responsible agent duly accredited in writing present for that purpose. Orders given to the contractor's duly authorised agent shall be considered to have the same force and effect as if they had been given to the contractor himself.

CLAUSE 19

The contractor shall give not less than five days notice in writing to the City Engineer or his subordinate in charge of the work before covering up or otherwise placing beyond the reach of measurement any work in order that the same may be measured and correct dimensions thereof taken before the same is covered up or placed beyond the reach of measurement, any work without the consent in writing of City Engineer or his subordinate in charge of the work and if any work shall be covered up or placed beyond the reach of measurement without such notice having been given or consent obtained, the same shall be uncovered at the contractor's expenses and in default thereof no payment or allowance shall be made for such work or for the materials with which the same was executed.

CLAUSE 20

If during the period of 2 (Two) years from the date of completion as certified by the Engineer in pursuant of clause 7 of the contract and after commissioning the work whichever is earlier in the opinion of the City Engineer, the said work is defective in any manner whatsoever the contractor shall forthwith on receipt of notice in that behalf from the City Engineer duly commence execution and completely carry out at his cost every respect all the work that may be necessary for rectifying and setting right the defects specified therein including dismantling and reconstruction of unsafe portions strictly in accordance with. and in the manner prescribed and under the supervision of the City Engineer. In the event of the contractor failing or neglecting to commence execution of the said rectification work within the period prescribed therefor in the said notice and/or to complete the same as aforesaid as required by the said notice, the City Engineer get the same executed and carried out departmentally or by any other agency at the risk on account and at the cost of the contractor. The contractor shall forthwith on demand pay to TMC, the amount of such cost,-charges and expenses sustained or incurred by the TMC, Thane of which the certificates of the City Engineer shall be final and binding on the contractor. Such costs, charges and

expenses shall be deemed to be arrears of land and revenue and in the event of contractor failing or neglecting to pay the same on demand as aforesaid without prejudice to any other right and remedies of the TMC, Thane the same may be recovered from the Contractor as the arrears of land revenue. The TMC, Thane shall also be entitled to deduct the same from any account which may then be payable or which may thereafter become payable by the TMC, Thane to the contractor either in respect of the said work or any other whatsoever or from the amount of security deposit retained by TMC, Thane.

CLAUSE 21

The contractor shall supply at his own cost all material (except such special materials if any as may be required in accordance with the contract, by supplied from the TMC Stores) plant, tools, appliances, implements, ladders, cordage, tackle, scaffolding and any temporary work required for the proper execution of the work, whether in the original, altered or substituted form, and whether included in the specification, or other documents forming part of the contract or referred to in these conditions or not and which may be necessary for the purpose of satisfying or complying with the requirements of the City Engineer as to any matter on which under these conditions he is entitled to be satisfied or which he is entitled to require together with carriage therefor, to and from the work. The contractor shall also supply without charge, the requisite number of persons with the means and materials necessary for the purpose of setting out work and counting, weighing and assisting in the measurement or examination at any time and from time to time of the works or the materials failing this the same may be provided by City Engineer at the expense of the contractor under the contract or from his deducted from any money due to the contractor under the contract or from his security deposits or the proceeds of sale thereof, or a sufficient portion thereof. The contractor shall provide all necessary fencing and lights required to protect the public from the accident, and shall also be bound to bear the expense or defense of every suit action or other legal proceedings, that may be brought by any person for injury sustained owing to neglect of the above precautions and to pay and damages and costs which may be awarded in any such suit action or proceedings to any such person, or which may with the consent of the contractor be paid in compromising any claim by any such person.

Signature of Contractor

No. of Corrections

City Engineer
TMC, Thane

List of machinery in contractor's possession and which they propose to use on the works should be Submitted alone, with the tender.

CLAUSE 21(A)

The contractor shall provide suitable scaffolds and working platforms, gangway and stairways and shall comply with the following regulations in connection herewith.

- a) Suitable scaffolds shall be provided for workmen for all work that cannot be safely done from a ladder or by other means.
- b) A scaffold cannot be constructed, taken down or substantially altered except
 - i) under the supervision of competent and responsible person and
 - ii) as far as possible by competent workers possessing adequate experience in this kind of work.
- c) All scaffolds and appliances connected therewith and all ladders shall:
 - i) be of sound material
 - ii) be of the adequate strength having regard to the loads and strains to which they will be subjected, and
 - iii) be maintained in proper condition.
- d) Scaffolds shall be so-constructed that no part thereof can be displaced in consequence of normal use.
- e) Scaffolds shall not be overloaded and so far as practicable the load shall be evenly distributed.
- f) Before installing lifting gear on scaffolds special precautions shall be taken to ensure the strength and stability of the scaffolds.
- g) Scaffolds shall be periodically inspected by a competent person.
- h) Before allowing a scaffold to be used by his workmen, the contractor shall, whether the scaffolds has been erected by his workmen or not, take steps to ensure that it complies fully with the regulations herein specified.
- i) Working platforms, gangways and stairways shall be so constructed that no part thereof can sag unduly or unequally.
- ii) to be constructed and maintained having regard to the prevailing conditions as to reduce as far as practicable risks of persons tripping or slipping, and
- iii) be kept free from any unnecessary obstruction.

- j) In the case of working platform and gangways working places and stairways at height exceeding 3 meters (to be specified)
- i) every working platform and every working gangway shall be closely boarded unless other adequate measures are taken to ensure safety.
- ii) every working platform and gangway shall have adequate width and
- iii) every working platform, gangway, working place and stairway shall suitably fenced.
- k) Every opening in the floor of building or in working platform shall except for the time and to the extent required to allow the access of persons or the transport or shifting or materials, be provided with suitable means to prevent the fall of persons or materials.
- l) When persons are employed on roof where there is danger of falling from the height exceeding two meters (to be prescribed) suitable precaution shall be taken to prevent the fall of persons or materials.
- m) Suitable precautions shall be taken to prevent persons being struck by articles which might fall from scaffolds or other working places.
- n) Safe means of access shall be provided to all working platforms and other working places.
- o) The contractors) will have to make payments to the labours as per minimum Wages Act.

CLAUSE 21(B)

The contractor shall comply the following, regulations as regards the Hoisting Appliances to be used by him:

- a) Hoisting machine and tackle, including their attachments, anchorages and support shall :
 - i) be of good mechanical construction, sound material and adequate strength and free from patent defect, and
 - ii) be kept in good repair and in good working order.
- b) Every rope used in hoisting, and lowering materials or as means of suspension shall be of suitable quality ;and adequate strength and free from patent defect.

- c) Hoisting machines and tackle shall be examined and adequately tested after erection on the site and before use and re-examined in position at intervals to be prescribed by the TMC, Thane.
- d) Every chain, ring, hook shackle, swivel and pulley block used in hoisting and lowering materials or as a means of suspension shall be periodically examined.
- e) Every crane driver or hoisting appliance operator shall be properly qualified.
- f) No person who is below the age of 21 years shall be in control of any hoisting machine including any scaffold which, or give signals to any operator.
- g) In the case of every hoisting machine and of every chain, ring, hook shackle, swivel and pulley block used in hoisting or lowering or as a means of suspension the safe working load shall be ascertained by adequate means.
- h) Every hoisting machine and all gears referred to, in the preceding regulation shall be plainly marked with the safe working load.
- i) In case of hoisting machine having available safe working loads, each safe working load and the conditions under which it is applicable shall be clearly indicated.
- j) No part of any hoisting machine or of any gear referred to in relation (g) above shall be loaded beyond the safe working load except for the purpose of testing.
- k) Motors, gearing transmission, electric wiring and other dangerous parts of hoisting appliances shall be provided with efficient safeguards.
- l) Hoisting appliances shall be provided with such means as will reduce to minimum the risk of the accidental decent of the load.
- m) Adequate precautions shall be taken to reduce to minimum the risk of any part of suspended load becoming accidentally displaced.

CLAUSE 22

The contractor shall not set fire to any standing, jungle, trees, brush wood or grass without a written permit from the City Engineer. When such permit is given, and also in all cases when destroying cut or dug up trees, brush wood, grass, etc. by fire the contractor shall take necessity measures to prevent such fire spreading to or otherwise

damaging, surrounding property. The contractor shall make his own arrangement for drinking water for the labour employed for him.

CLAUSE 23

Compensation for all damages done intentionally or unintentionally by contractor's labours whether in or beyond the limits of TMC, Thane property including any damage caused by the spreading or fire mentioned in clause 22 shall be estimated by City Engineer or such other officer as he may appoint and the estimates of the City Engineer shall be final and the contractor shall be bound to pay the amount of the assessed compensation on demand, failing which, the same will be recovered from the contractor as damages in the manner prescribed in clause I or deducted by the City Engineer from any sums that may be due or become due from TMC, Thane to contractor under this contract or otherwise.

The contractor shall bear the expenses of defending any action or other legal proceedings that may be brought by any persons for injury sustained by him owing to neglect of precautions to prevent the spread of fire and he shall also pay any damages and costs that may be awarded by the court in consequence.

CLAUSE 24

The employment of female labours on works in the neighborhood of soldier's barracks should be avoided as far as possible.

CLAUSE 25

No work shall be done on a Sunday without the sanction in writing of the City Engineer.

CLAUSE 26

The contract shall not be assigned or sublet without the written approval of the City Engineer. And if the contractor shall assign or sublet his contract, or attempt to do so or become insolvent or commence any proceedings to get himself adjudicated and insolvent or make any composition with his creditors or attempt to do so, the City Engineer may, by notice in writing rescind the contract. Also if any bribe, gratuity, gift, loan prerequisite, reward or advantage, pecuniary or otherwise, shall either directly or indirectly be given, promised or offered by the Contractor, or any of his servants or agents to any public officer or person in the employment of the TMC, Thane in any way relating to his office or employment, or if any such officer or person shall become in any way directly or indirectly interested in contract the City Engineer maybe notice in writing rescind the contract. In the event of contract being rescinded, the security deposit

of the contractor shall thereupon stand forfeited and be absolutely at the disposal of TMC, Thane, and same consequences shall ensure as if the contract had been rescinded under clause 3 hereof and in addition the contractor shall not be entitled to recover or be paid for any work therefore actually performed under the contract.

CLAUSE 27 All sums payable by a contractor by way of compensation under any of these conditions shall be considered as reasonable compensation to be applied to use of TMC, Thane without reference to the actual loss or damage sustained, and whether any damage has or has not been sustained.

CLAUSE 28 In the case of tender by partners, any changes in the constitution of firm. shall be notified by the contractor to the City Engineer for his information.

CLAUSE 29 All works to be executed under the contract shall be executed under the direction and subject to the approval in all respects of the City Engineer of the TMC, Thane for the time being, who shall be entitled to direct at what points and in what manner they are to be commenced and from time to time carried on.

CLAUSE 30 1. City Engineer for the time being shall be final conclusive and binding on all parties to the contract upon all questions relating to the meaning of the specifications, designs, drawings and instructions herein before mentioned and as to the quality of workmanship or material used on the work, or as to any other question, claim, right matter, or thing, whatsoever, if any way arising out of, relating to the contract, designs, drawings, specifications estimates, orders or these conditions or otherwise concerning the works, or the execution, or failure to execute the same, whether arising, during the progress of the work, or after the completion or abandonment thereof. This Clause is not an Arbitration Agreement.

2. The contractor may, with-in thirty days of receipt of him by any order passed by the City Engineer of the TMC, Thane as aforesaid, appeal against it to the Municipal Commissioner concerned with the contract, work or project provided that-

a) The accepted value of the contract exceeds Rs. 10 Lakhs (Rupees Ten Lakhs Only)

Signature of Contractor

No. of Corrections

City Engineer
TMC, Thane

- b) Amount of claim is not less than Rs. 1 Lakh (Rupees One Lakh)

CLAUSE 31

The contractor shall obtain from the TMC, Thane all stores and articles of European and American manufacturer which may be required for work, or any part thereof or in making up any articles required thereof in connection therewith unless he has obtained permission in writing from the City Engineer to obtain such store articles elsewhere. The value of such stores and articles as may be supplied to contractor by the City Engineer will be debited to the contractor in his account at the rates shown in the schedule in form A attached to the contract and if they are not entered in the said schedule, they shall be debited to him at the cost price which for the purpose of this contract shall include the cost of carriage and all other expenses whatsoever, which shall have to be incurred in obtaining delivery of the same at the stores aforesaid.

CLAUSE 32

When the estimates on which a tender is made includes lump sum in respect of part of the work, the contractor shall be entitled to payment in respect of items of work involved or the part of the work in question at same rates as are payable under this contract for such items, or of the part of the work in question is not in opinion of the City Engineer capable of measurement, the City Engineer may at his discretion pay the lump sum amount entered in the estimate, and the certificate in writing of the City Engineer shall be final and conclusive against the contractor with regard to any sum or sums payable to him under the provision of this clause.

CLAUSE 33

In the case of any class of work for which there is no such specifications as is mentioned in rule 1. Such work shall be carried out in accordance with the TMC prescribed specifications, and in the event of there being, no TMC prescribed specification then in Such case then work shall be carried out in all respects in accordance with the instructions and requirements of the City Engineer.

CLAUSE 34

The expression 'work' or 'works' where used in these conditions shall unless there be something in the subject or context repugnant to Such construction be constructed to mean the work or the works contracted, to be executed under or in virtue of the contract, Whether temporary or permanent and whether original, altered, substituted or additional.

Signature of Contractor

No. of Corrections

City Engineer
TMC, Thane

- CLAUSE 35** The percentage referred to in the tender shall be deducted from/ added to the gross amount of the bill before deducting the value of any stock issued.
- CLAUSE 36** All quarry fees, royalties, octroi dues and ground rent for stacking materials, if any should be paid by the contractor.
- CLAUSE 37** The contractor shall be responsible for and shall pay any compensation to his workmen payable under the Workmen's Compensation Act, 1923 (VIII of 1923) (hereinafter called the said act) for injuries caused to the workmen. If such compensation is payable and paid by TMC, Thane as principal under sub-section (i) of section- 12 of the said act, on behalf of the contractor, this shall be recoverable by the TMC, Thane from the contractor under sub-section (2) of the said section. Such compensation shall be recovered in the manner laid down in clause (1) above.
- CLAUSE 37(A)** The contractor shall be responsible for and shall pay the expenses of providing medical aid to any workmen who may suffer a bodily injury as a result of an accident. If such expenses are incurred by TMC, Thane the same shall be recoverable from the Contractor forthwith and deducted without prejudice to any other remedy of TMC, Thane from any amount due or that may become due to the contractor.
- CLAUSE 37(B)** The contractor shall provide all necessary personal safety equipment and first-aid apparatus available for the use of the persons employed on site, and shall maintain the same in condition suitable for immediate use at any time and shall comply with the following regulations in connection therewith.
- a) The worker shall be required to use the equipment so provided by the contractor and the contractor shall take adequate steps to insure proper use of the equipment by those concerned.
 - b) When work is carried on in proximity to any place where there is a risk of drowning, all necessary equipment shall be provided and kept ready for use and all necessary steps shall be taken for the prompt rescue of any person in danger.
 - c) Adequate provision shall be made for prompt first aid treatment of all injuries likely to be sustained during, the course of the work.

CLAUSE 37(C) The contractor shall duly comply with the provisions of “THE APPRENTICES ACT, 1961” (III of 1961), the rules made thereunder and the thereunders that may be issued from time to time under the said act and the said rules and on the failure or neglect to do so lie shall be subjected to all the liabilities and penalties provided by the said act and the said rules.

- CLAUSE 38**
- 1) Quantities in respect of the several items shown in the tender are approximate, and no revision in the tendered rate shall be permitted in respect of any of the items so long as, subject to any special provision contained in the specifications, prescribing different percentage of permissible variations or the quantity of the item does not exceed 40% of the tender quantity which shall be finalized at the time of pre-bid meeting.
 - 2) The contractor shall, if ordered in writing by the City Engineer so to do, also carry out any quantities in excess of the limit mentioned in sub-clause (1) hereof on the same conditions as and in accordance with the specifications in the tender and on at the rates (i) derived from the rates entered in the current schedule of rates and in the absence of such rates, (ii) at the rate prevailing in the market, the said rates being decreased in case percentage quoted by the contractor is below to which the total tendered amount upon the schedule of rates applicable to the year in which the tender were invited. For purpose of operation of this clause, this cost shall be taken to be **Rs 14,33,11,000/- (In Words Rupees Fourteen Crore Thirty three Lakh Eleven Thousand Only)**.
 - 3) The quantities shown in the tender are tentative and may be reduced. No compensation or increase in rate will be applicable if quantities are reduced.
 - 4) There is no change in the rate for the excess upto 40% of the tendered quantity.
 - 5) In case of item for which quantities shown as zero, contractor has to execute the work upto the sum of Rs. 5.00 Lacs (Rs. Five Lacs) as directed by the city engineer at the tendered rate.
 - 6) In case of **Extra item** for which rates are not given in tender, current D.S.R. rate or percentage below on current D.S.R. rate quoted by contractor which ever is less will be applicable and if rates are not

specified in DSR , rate of such items will be calculated by rate analysis based on market rates without applying tender condition and no escalation will be paid on extra items.

CLAUSE 39 The contractor shall employ any famine, convict or other labour of particular kind or class if ordered in writing to do so by the City Engineer.

CLAUSE 40 No compensation shall be allowed for any delay caused in the starting of the work, on account of any acquisition of land or in the case of the clearance works, on account of any delay in according sanction to estimates.

CLAUSE 41 No compensation shall be allowed for any delay in execution of work on account of water standing in borrow pits or compartments. The rates are inclusive of hard or cracked soil excavation in mud, sub-soil water or water standing in borrow pits and no claim for extra rates shall be entertained, unless otherwise expressly specified.

CLAUSE 42 The contractor shall not enter upon or commence any portion of work except with the written authority and instruction of the City Engineer or of his subordinate in-charge of the work. Failing such authority the Contractor shall have no claim to ask for measurement of or payment of work.

CLAUSE 43

- i) No contractor shall employ any person who is under the age of Eighteen (18) years.
- ii) No contractor shall employ donkeys or other animals with bracing of string or thin rope. The bracing must be at least 3 inches wide and should be of tape (Nawar.)
- iii) No animal suffering from sores, lameness or emaciation or which is immature shall be employed on the work.
- iv) The City Engineer or his agent is authorised to remove from the work any person or animal found which does not satisfy these conditions and no responsibility shall be accepted by the TMC, Thane for any delay caused in the completion of work by such removal.
- v) The contractor shall pay fair and reasonable wages to the workmen employed by him in the contract undertaken by him in the event of any dispute arising between the contractor and his workmen on the ground, that the wages paid are not fair and reasonable the dispute

shall be referred without delay to the City Engineer who shall decide the same. The decision of the city Engineer shall be conclusive and binding on the contractor, but such decision shall not affect the contractor, but such decision shall not in any way affect the condition in the contract regarding the payment to be made by TMC, Thane at the sanctioned tender rates.

- vi) The contractor shall provide drinking water facility to the workers. Similar amenities shall be provided to the workers engaged on large works in urban areas.
- vii) Contractor is to take precaution against accidents which takes place on account of labour using loose garments while working near machinery.

CLAUSE 44 Payment to contractors shall be made by cheques drawn on any Bank within the TMC limits convenient to them, provided the amount exceeds Rs. 100/- Amounts not exceeding Rs. 100/- will be paid in cash.

CLAUSE 45 Any, contractor who does not accept these conditions shall not be allowed to tender for works.

CLAUSE 46 If Government declares a state of scarcity or famine to exist in any village situated within 16 km. of the work in contractor shall employ upon such parts of the work, as are suitable for unskilled labour any person certified to him by the City Engineer or by any person to whom the City Engineer may have delegated this duty in writing to be in need of relief and shall be bound to pay to such persons wages not below minimum which Government have fixed in this behalf. Any disputes which may arise in connection with the implementation of this clause shall be decided by the City Engineer whose decision shall be final and binding on the contractor.

CLAUSE 47 The price quoted by the contractor shall not in any case exceed the control price if any fixed by Government or reasonable price which is permissible for him to charge a private purchaser for the same class and description of goods the controlled price permissible under the provisions of Hoarding and Preventions Ordinance, 1943, as amended from time to time. If the price quoted exceeds the controlled price of the price permissible under Hoarding and Preventions Ordinance the contractor shall specifically mention this fact in his tender along with

Signature of Contractor

No. of Corrections

City Engineer
TMC, Thane

reasons for quoting such higher price. The purchaser at his discretion will in such case exercise the right of revising the price at any stage so as to conform with the controlled price permissible under the hoarding and Profiteering Prevention Ordinance. This discretion will be exercised without prejudice to any other action that may be taken against the contractor.

CLAUSE 47 (A) “The tendered rates shall be inclusive of all taxes, and shall also be inclusive of the tax leviable in respect of works contract under the provision of the Maharashtra Sales Tax on transfer of property or goods involved in the execution of works Contract Act, 1985 (Maharashtra Act NO.XIX of 1985)”.

CLAUSE 48 The rates to be quoted by the contractor must be inclusive of Sales Tax., Work Contract Tax etc. No extra payment on account of this will be made to the contractor.

CLAUSE 49 In case of materials that may remain surplus with the contractor from those issued for the work contracted for the date of ascertainment of the materials being surplus will be taken as date, of sale for the purpose of sales tax and the sales tax will be recovered on such sale.

CLAUSE 50 The contractor shall employ unskilled labour to be employed by him on the said work only locally available labour and shall give preference to those persons enrolled under Maharashtra Government Employment and Self Employment Departments Scheme.

Provided, however that if required unskilled labour not available, locally the contractor shall in the first instance employ such number of persons as is available and thereafter may with previous permission in writing of the City Engineer in charge of the said work, obtain the rest of the requirement of unskilled labour from outside the above scheme.

CLAUSE 51 The contractor shall pay the labourer skilled and unskilled according to the wages prescribed by the Minimum Wages Act, 1948 applicable to the area in which the work of the contractor is in progress.

A contractor shall comply with the provisions of the Apprentice Act, 1961 and the rules and the orders issued thereunder from time to time. If he fails to do so his failure will be breach of the contract and the City Engineer may, in this discretion, cancel the contract. The

contractor shall also be liable for any pecuniary liability arising on account of any violation by him of the provision of the act.

The contractor shall pay the labourers skilled and unskilled according to the wages prescribed by the Minimum Wages Act of 1948 applicable to the area in which the work of the contractor is in progress.

CLAUSE 52

All amount whatsoever the contractor is liable to pay to the TMC, Thane in connection with the execution of the work including the amount payable in respect of (i) materials and/or stores supplied/issued hereunder by the TMC Thane to the contractor, (ii) higher charges in respect of heavy plant, machinery and equipment on hire by TMC, Thane to the contractor for execution by him of the work and/or on which advances have been given by the TMC, Thane to the contractor shall be deemed to be arrears of land revenue and the TMC, Thane to the contractor shall be deemed to be arrears of land revenue and the TMC, Thane, may without prejudice to any other right and remedies of the, TMC, Thane, recover the same from the contractor as arrears of land revenue.

CLAUSE 53

The contractor shall duly comply with all the provisions of the contract labour (Regulation and Abolition) Act, 1970 (37 of 1970) and the Maharashtra contract labour (Regulation & Abolition) Rules 11 971 as amended from time to time and all other relevant statutes and statutory provisions thereof concerning payments of wages particularly to workman employed by the contractor and workman on the site of the work. In particular the contractor shall pay wages to each worker employed by him on the site of the work at the rates prescribed under the Maharashtra contract labour (Regulation & Abolition) Rules 1971. If the contractor fails or neglects to pay wages at the said rates or makes short payment ad TMC, Thane makes such payment of wages in full or part thereof less paid by the contractor as the case may be, the amount so paid by the TMC, Thane to such workers shall be deemed to be arrears of land revenue and the TMC, Thane shall be entitled to recover the same as such from the contractor or deduct the same from the amount payable by the TMC, Thane to the contractor hereunder or from any other amount's payable to him by the TMC, Thane. (Inserted vide Govt. Public Works Department's Circular NO. CAT 1284\120) Building-dt 14.8.1985.

Signature of Contractor

No. of Corrections

City Engineer
TMC, Thane

Accompaniments to the G.R.P.W.D. No. BGD.1979\64188(358) Desk - 2 dt.4\2\1981.

CLAUSE 54 The contractor shall engage apprentices such as brick layer, carpenter, wiremen, plumber as well as black smith recommended by the State Apprenticeship Advisor, Director of Technical Education, Dhobi Talav, Mumbai - 400 001, in the construction work (As per Government of Maharashtra, Education Departments circular No.TSA/5170/T/56689, dated 7/7/1972).

CLAUSE 55 (Govt. of Maharashtra P.W.D. Resolution NO.CAT- 1086/CR-243/K/Bldg.2 dt. 1 1/8/1987.)

CONDITIONS FOR MALARIA ERADICATION, ANTI-MALARIA AND OTHER HEALTH MEASURES

- a) Anti malaria and other health measures shall be as directed by the Joint Director (Malaria and Fileria of health services, Pune).
- b) Contractor shall see that mosquitogenic conditions are not created so as to keep vector population to minimum level.
- c) Contractor shall carry out anti-malaria measures in the area as per guidelines prescribed under National Malaria Eradication pro-ram and as directed by the Joint Director (M&F) of Health Services, Pune.
- d) In case of default in carrying out prescribed anti-malaria measuring resulting in increase in malaria incidence Contractor shall be liable to pay to TMC, Thane the amount spent by TMC, Thane on anti-malaria measures to control the situation in addition to fine.
- e) Relations with Public Authorities: The contractor shall make sufficient arrangements for draining away the sewerage water as well as water coming from the bathing and washing places and shall dispose of this water in such a way as not to cause any nuisance. He shall also keep the premises clean by employing sufficient number of sweepers. The contractor shall comply with all rules regulations by laws and directions given from time to by any local or public authority in connection with this work shall pay fees or charges which are leviable on him without any extra cost to TMC, Thane.

Signature of Contractor

No. of Corrections

City Engineer
TMC, Thane

Chapter – IX

Price Variation Clause

Signature of Contractor

No. of Corrections

City Engineer
TMC, Thane

CHAPTER IX

PRICE VARIATION CLAUSE

NAME OF WORK:- Improvement of Kolshet road (From kapurbavdi naka to Airforce station) as Model Road by Renovation and Beautification of Existing Road followed by maintenance for 3 years.

This clause is applicable only for Schedule 'B' – not applicable for works costing less than Rs. 5 Lakhs

If during the Operative Period of the contract as defined in condition (i) below, there shall be any variation in the Consumer Price Index (New Series) for industrial workers for Mumbai Center as per the labour Gazette published by the Commissioner of Labour, Govt. of Maharashtra and or in the wholesale Price Index for all commodities prepared by the office of Economic Adviser, Ministry of Industry, Govt of India, or in the price of petrol / oil and Lubricants and Major construction materials like bitumen, cement, steel, etc, then subject to the other conditions mentioned below, price adjustment on account of

- (1) Labour Component
- (2) Material Component
- (3) Petrol, oil and Lubricants Component
- (4) Bitumen Component
- (5) HYSD & Mild Steel Component
- (6) Cement Component

Calculated as per the formula hereinafter appearing, shall be made Apart from these, no other adjustments shall be made to the contract price for any reasons whatsoever. Component percentage as given below are as of the total cost of work put to tender. Total of Labour, Material & POL components shall be 100 and other components shall be as per actuals.

- | | |
|---------------------------------|---------|
| (1) Labour Component –K1 | (35 %) |
| (2) Material Component –K2 | (57 %) |
| (3) POL Component –K3 | (8 %) |
| (4) Bitumen Component | Actual |
| (5) HYSD & Mild Steel Component | Actual |
| (6) Cement Component | Actual |

Note :- if Cement, Steel, Bitumen are supplied on schedule A and then respective component shall not be considered. Also if particular component is not relevant same shall be deleted.

The star rates are given as below.

Signature of Contractor

No. of Corrections

City Engineer
TMC, Thane

- Cement :- Rs. 6,600/- per M.T.
- H.Y.S.D. Steel :- Rs. 45,150/- per M.T.
- Mild Steel :- Rs. 39,900/- per M.T.
- Bitumen PMB (40 Grade) :- Rs. 50,048/- per M.T.
- Bitumen CRMB (60 Grade) :- Rs. 41,043/- per M.T.

(A) FORMULA FOR LABOUR COMPONENT

$$V_1 = 0.85 (P - \text{Cost of schedule 'A' Material used}) \times [(K_1/100) \times (C_1 - C_0)/C_0]$$

Where,

- V_1 = Amount of price variation in Rupees to be allowed.
 P = Cost of work done during the period under consideration.
 K_1 = Percentage of labour component as indicated above.
 C_0 = Basic Consumer Price Index for Mumbai Center, shall be average consumer price index for the quarter preceding the month in which the last date prescribed for receipt of tender.
 C_1 = Average Consumer Price Index for Mumbai Center during the period under consideration.

(B) FORMULA FOR MATERIAL COMPONENT.

$$V_1 = 0.85 (P - \text{Cost of schedule 'A' Material used}) \times [(K_2/100) \times (I_1 - I_0)/I_0]$$

Where,

- V_1 = Amount of price variation in Rupees to be allowed.
 P = Cost of work done during the period under consideration.
 K_2 = Percentage of material component as indicated above.
 I_0 = Basic Wholesale Price Index shall be average wholesale price index for the quarter preceding the month in which the last date prescribed for receipt of tender.
 I_1 = Average Wholesale Price Index during the period under consideration.

(C) FORMULA FOR PETROL, OIL, LUBRICANT COMPONENT

$$V_1 = 0.85 (P - \text{Cost of schedule 'A' Material used}) \times [(K_3/100) \times (P_1 - P_0)/P_0]$$

Where,

- V_1 = Amount of price variation in Rupees to be allowed.

Signature of Contractor

No. of Corrections

City Engineer
TMC, Thane

- P = Cost of work done during the period under consideration.
- K_3 = Percentage of petrol, oil and lubricant component.
- p_1 = Average price of H.S.D. for Thane during the period under consideration.
- P_0 = Average price of H.S.D. for Thane for the quarter preceding the month in which the last date prescribed for receipt of tender.

D) Formula for Bitumen Component

$$V_4 = QB (B_1 - B_0)$$

Where,

V_4 = Amount of price variation in Rupees to be allowed for Bitument Component.

QB = Quantity of Bitument (Grade..) in metric tonnes used in the permanent works and approved enabling works during the period under consideration.

B_1 = Average ex-refinery price per metric tonne of Bitument (Grade...) during the period under consideration including all applicable taxes during the quarter under consideration.

B_0 = Basic rate of Bitumen in rupees per metric tonne as considered for working out value of P or average ex-refinery price in rupees per metric ton including taxes (octroi, excise sales tax, etc) of Bitumen for the grade of bitumen under consideration prevailing quarter preceding the month in which the last date prescribed for receipt of tender, falls, whichever is higher.

E) Formula for HYSD and Mild Steel Component.

$$V_5 = \frac{S_0 (S_1 - S_0)}{S_0} \times T$$

Where,

V_5 = Amount of price variation in Rupees to be allowed fro HYSD / Mild Steel Component.

S_0 = Basic rate of HYSD / Mild steel in rupees per metric tonne as considered for working out value of P

SI_1 = Average Steel Index published in the RBI bulletin during the quarter under consideration.

SI_0 = Average of Steel Index published in the RBI bulletin for the quarter preceding the month in which the last date prescribed for receipt of tender falls.

T = Tonnage of steel used in the permanent works for the period under consideration.

F) Formula For Cement Component.

$$V_6 = \frac{C_0 (CI_1 - CI_0)}{CI_0} \times T$$

Where,

V_6 = Amount of price escalation in Rupees to be allowed for cement component.

C_0 = Basic rate of cement in rupees per metric ton as considered for working out value of P.

CI_1 = Average cement index published in the RBI bulletin during the period under consideration .

CI_0 = Average of cement Index published in the RBI bulletin for the quarter preceding the month in which to the last date prescribed for receipt of tender falls

T = Tonnage of cement used in the permanent works for the quarter under consideration.

II. Conditions referred to in para - I

(i) The operation period of the contract shall mean the period commencing from the date of the work order issued to the Contractor and ending on the date when the time allowed for the work specified in the Memorandum under tender for works expires, taking into consideration the extension of time, if any for completion of the work granted by Engineer-in-charge under relevant clause of the conditions of contract in case other than those where such extension is necessitated on account of default of the Contractor. The decision of the Engineer-in-charge as regards the operative period of the contract shall be final and binding on the Contractor. Where

compensation for liquidated damages is levied on the Contractor on account of delay in completion or inadequate progress under the relevant contract provisions the escalation amount for the balance work from the date of levy of such compensation shall be worked out by pegging the indices C_1 , I_1 and P_1 to levels corresponding to the date from which such compensation is levied.

(ii) This price variation clause shall be applicable to all contracts in B-1, B-2 and C forms but shall not apply for piece work.

(iii) Price variation shall be calculated in accordance with the formulas mentioned above, separately for labour, material and POL components.

(iv) The price variation under this clause shall not be payable for the extra items required to be executed during the completion of the work and also on the excess quantities payable under the provisions of clause 38/37 of the contract form B-1/ B-2 respectively. since rates payable for the extra items or the extra quantities under clause 38/37 are to be fixed as per the current DSR or as mutually agreed subject to yearly revision till completion of such work. In other words, when the completion or execution of extra items as well as extra quantities under clause 38/37 of the contract form B-1/ B-2 extends beyond the operative date of the DSR. The rates payable for the same beyond that date shall be revised with reference to the next / current DSR, prevalent at the time, on year to year basis or revised in accordance with mutual agreement thereon as provided for in the contract whichever is less.

a. This clause is operative both ways i.e. if the price variation in the said Wholesale Price Index (New Series) or price of HSD for Thane is on the plus side, payment on account of the price variation shall be allowed to the Contractor and if it is on negative side, the TMC shall be entitled to recover the same from the Contractor and the amount shall be deductible from the Contractors bill for the respective period in which there are fluctuations.

Annexure-I

Department of Registrar of firms has 4 offices in Maharashtra situated at Mumbai,Pune, Nagpur and Aurangabad. The address of offices are as follows.

1)Registrar of firms, Maharashtra State, Mumbai.

New Administrative Building, 6th Floor,
Near Chetna Collage, Govt. Colony,
Bandra(E), Mumbai 400051.
Ph No. 022-26551149,022-26551944.

2) Assistant Registrar of firms, Pune.

Survey No.47/30, Sarswati parvati Bhavan,
2nd floor, Behind Lokesh Hotel,
Arnyshwar Corner, Pune Satara Road,
Pune 411009
Ph. No. 95250-24221808

3) Assistant Registrar of firms, Nagpur.

118,old Sachivalay Building,
Civil Lines, Nagpur 440001.
Ph.No.95712-2530897

4) Assistant Registrar of firms, Aurangabad.

Gadiya Building, House No. 5/1/100,
Near Divisional library Office,
Eknathnagar Road, Usmanpura,
Aurangabad 431005.
Ph.no.952402336798

THANE MUNICIPAL CORPORATION,THANE
PUBLIC WORKS DEPARTMENT

ANNEXURE II

List of approved make of Electrical Items.

1	Lamps / Tubes	Crompton Greaves, Philips, Bajaj, G.E., Cema, Osram
2	2 Tube light fitting	2 Phillips, Crompton Greaves, G.E., Bajaj, Canara. Havels
3	Electronic Ballast	3 Asian Electronic, Urja Udyog, Philips, Osram, G.E. Havels
4	4 Wires	4 Pyroflex, Philco, Ambica, Finolex, Cobra, Gulmarg, Vishal, Polycab
5	Switches	5 Roma, Anchor, Cona, Modern (Ace).
6	6 Contactor, Fuse, Starter & Relays	Siemens, Crompton Greaves, EE & BCH., L & T. , Havels
7	Main Switch & cut out	7 K.E.W., Stanlay, Crompton Greaves , Bharat Trishul, Havels
8	D.B. & MCB/MCCB & Isolator/ Switchgear	Siemens/L&T/Schneider/ Legrand/ Indo Asian
9	Fan & Ex-fans	9 Crompton Greaves, Khaitan, Polar, Orient, Usha., Havels
10	Fan regulators electronic	Anchor & Rider, Cona, Havels
11	Pump	Kirloskar, Crompton Greaves, Jyoti, Beacon.
12	lugs and Glands	Dowells & Standard, Lotus
13	Water heater	cold, Superheat
14	PVC casing Capping	Presto, Precision, Modi.
15	PVC Conduit pipe	Presto, Precision
16	Water Cooler	Tushar, Usha, Videocon, Blue star
17	Air Conditioner	Volta's, Videocon, National, Blue star, L.G.Carrier

Signature of Contractor

No. of Corrections

City Engineer
TMC, Thane

18	18 Generator set. Diesel Engine	Cummins India Limited , Greaves Limited , Caterpillar, Kirloskar oil Engines Limited.
19	Alternator	Stamford, Kirloskar Electric company, Crompton Greaves limited , AVK SEGC.
20	LED Fitting	Phllips, Bajaj, G.E., Crompton Greaves. keselec Schreder.
21	PVC Copper stranded wire	Finolex, Philco, Gulmarg, Vishal, Ambika
22	HPSV/M.V.Lamp/ Metal Halide Lamps	Phllips, Bajaj, Crompton Greaves, Osram
23	FRP Box	United , M.P. , Ravi , National , SP, Madhuri Engineering Works
24	PVC/XLPE Cable	Asian Cables , C.C.I. Cables, Polycab, Prime Cable, Vishal, Finolex, Gulmarg, BHARAT- CAB.
25	Epoxy straight through L.T. Joint Kit	Super Seal, MSEAL, GRIP - S
26	Cable Lugs	Dowels, Standard
27	G. I. Pipe	ISI mark
28	PVC pipe	Finolex or equivalent approved make
29	L.T. Contactor	Siemens, L&T, Cuttler hammer
30	Panel	Should be fabricated from CRCA Sheet , powder coated& it should be approved by . City Engineer
31	Octagonal Poles	Bajaj, Valmont, keselec Schreder, Transrail.

Note: 1. For any make other than specified above it should be approved by City Engineer TMC Thane.

2 LED fixtures of makes other than above approved makes, meeting all technical & lighting parameters may be approved after testing of fixtures in NABL accredited laboratory accredited for testing of LED fixture

Signature of Contractor

No. of Corrections

City Engineer
TMC, Thane

X
Schedule 'A'
.....DELETED.....

Signature of Contractor

No. of Corrections

City Engineer
TMC, Thane

XI
Schedule 'B'

Signature of Contractor

No. of Corrections

City Engineer
TMC, Thane

Name of Work : Improvement of Kolshet Road (From Kapurbawdi Naka To Air Force Station) as Model Road by Renovation and Beautification of Existing Road. followed by maintenance for 3 years.

ABSTRACT

It. No.	Description	Quantity	Unit	Rate	Total Amount
1	2	7	8	9	10
1	Excavation for roadways in soft rock including dressing to the required grade camber and side slopes and conveying the excavated materials with all lifts upto a lead of 50m and spreading or stacking as directed.				
	(PWD DSR 2015-16 It No 3 a IV. Page NO 157)	2184.71	CuM	299.06	653357.88
2	Excavation for roadways in soft strata such as earth soil of all sorts,sand, gravel,or soft murum.....including dressingsection to required grade,camber and sides slopes and conveying the excavated materials with all lifts upto lead of 50m and spreading for embankment or stacking, disposing as directed.				
	(PWD DSR 2015-16 It No 3 a I. Page NO 157)	3753.80	CuM	119.84	449855.69
3	Compacting hard murum/sub grade/gravel oversize metal (200mm loose) with vibratory roller including artificial watering complete.				
	(PWD DSR 2015-16 It No 24 A Page NO 161)	14347.50	SqM	21.21	304310.48
4	Providing and laying wedge shear elemental layer (WSEL) by using rubble stone of size 15 to 20 cm thick in single layer of 230 mm including packing the same with 20 mm to 40 mm thick aggregates (normal size) and using stone powder of 40 mm to 50 mm thick on surface and watering & compacting by vibratory roller confirming layer thickness of minimum 200 mm and as directed by Engineer - in - charge etc complete.				
	RA	927.02	CuM	1475.79	1368079.47
5	Providing and laying 50 mm metal for water bound macadam of consolidated thickness 75 mm,including powdering,watering,compacting by vibratory roller etc.complete.- Grade II				
	(PWD DSR 2015-16 It No 29 B i Page No 163)	2152.13	CuM	1726.66	3715988.15

Signature of Contractor

No. of Corrections

City Engineer
TMC, Thane

6	Providing and laying insitu rolled cement concrete 1:2:4 of trap metal for levelling course including steel channel formwork,compacting using 8 to 10 T roller, curing using hessin cloth etc. complete.				
	(PWD DSR 2015-16 It No 1 A ii Page No16)	2168.42	CuM	5738.34	12443102.53
7	Providing and laying tack coat on water bound macadam surface,incl.supplying all materials preparing existing surface heating bitumen & applying bitumen @ 75 kg per 100 sq.m. on the surface etc. complete.				
	(PWD DSR 2015-16 It No 34 b. Page No 165)	14347.50	SqM	55.15	791264.63
8	P/L bituminous tack coat on B.T.Surface macadam surface,incl.supplying all materials preparing existing surface heating bitumen & applying bitumen @ 50kg per 100 Sq.m. on the surface etc. complete.				
	(PWD DSR 2015-16 It No 34 a. Page No 165)	38420.50	SqM	39.24	1507620.42
9	P/L hotmix hotlaid Dense bituminous macadam 75mm average thickness with 4.25% bitumen by wt. of total mix for leveling course to remove irregularities including diversion of traffic supplying all materials heating bitumen 30-40 grade and chips mixing bitumen & chip in hot mix plant laying bituminous macadam by paver finisher including compaction with vibratory roller etc.(excluding tack coat) etc. complete.				
	Approved rate	1137.15	CuM	7054.56	8022092.90
10	P/L hot premix asphaltting concrete with 5.4% to 5.6% of bitumen grade 30-40 surface coat by mix design as per MORTH to the compacted thk. of 40 mm, using new material to the required line, level, camber using mechanical compactor and finisher, rolling etc. complete as specified and as directed with lime filler 5% by weight & antistripping agent @ 1% of bitumen content by weight etc. complete.				
	Approved rate	1536.82	CuM	9188.78	14121500.88

Signature of Contractor

No. of Corrections

City Engineer
TMC, Thane

11	Providing and laying 25 mm thick mastic asphalt. wearing course on top of deck slab excluding prime coat with paving grade bitumen meeting the requirements given in table 500-29, prepared by using mastic cooker and laid to required level and slope after cleaning the surface, including providing antiskid surface with bitumen precoated fine grained hard stone chipping of 9.5 mm nominal size at the rate of 0.005 cum per 10 Sqm and at an approximate spacing of 10 cm center to center in both directions, pressed into surface when the temperature of surfaces not less than 100 deg. C, protruding 1 mm- to 4mm over mastic surface, all complete as per clause 516.				
	Approved rate	3000.00	SqM	1216.00	3648000.00
12	Providing and fixing cast in situ parabolic central divider of M-20 grade and applying 2 coats of flat oil paint etc. complete. (0.3 mX 0.15 m X 1.22 m ht)				
	RA	100.00	Rmt	4003.80	400380.00
13	Providing , supplying and fixing Precast parabolic central divider of M-20 grade and applying 2 coats of flat oil paint etc. complete. (0.3 mX 0.15 m X 1.22 m ht)				
	RA	190.00	Rmt	2995.31	569108.90
14	Providing and laying precast cement concrete kerbs M20 (1:1 1/2: 3) with chamfered faces as per detailed drawing including necessary excavation in any material except rock and (necessary)reinforcement including painting the exposed surface of kerb with one coat of road marking paint and removing excavated stuff etc. complete.				
	RA	2020.90	Rmt	1018.56	2058407.90
15	P/F Precast C.C. M-20 water tables 30 centimetre wide and 10 centimetre thick on a M10 cement concrete bed 15 centimetre thick including filling in thee joints with cement mortar 1:2 cement pointing,curing etc. complete,as specified and as directed.				
	RA	2020.90	Rmt	755.44	1526668.70
16	Removing & resetting Kerb stones				
	RA	866.10	Rmt	686.38	594473.72

Signature of Contractor

No. of Corrections

City Engineer
TMC, Thane

17	Removing & resetting water table				
	RA	866.10	Rmt	488.54	423124.49
18	Providing and laying R.C.C. runner beams in M40 cement concrete of width 23cm & depth 30 cm with 12mm m.s. main bars 4nos.6mmdia.m.s.rings at 15cm c/c and 12mm dia anchors at 50cm c/c to be anchored in sleeper slab properly,completed as specified and as per drawing ,including curing etc.--- complete.(Steel will not be paid separately)				
	RA	543.00	Rmt	640.34	347704.62
19	P/F of interlocking concrete lacqured coated Pavers of any shape 80mm thick 35 Mpa 45 mm bed				
	(PWD DSR 2015-16 It No 41 Page No65	814.50	SqM	1123.07	914740.52
20	Providing and Laying in trenches medium grade ISI mark GI pipes with necessary fittings including necessary excavation trench filling applying anti-corrosive paint and two coats of oil paint etc.complete. - 15 mm. Dia.				
	(PWD DSR 2015-16 It No 5 B a. Page No 122)	100.00	Rmt	250.28	25028.00
21	Providing and Laying in trenches medium grade ISI mark GI pipes with necessary fittings including necessary excavation trench filling applying anti-corrosive paint and two coats of oil paint etc.complete. - 20mm dia				
	(PWD DSR 2015-16 It No 5 B b. Page No 122)	50.00	Rmt	320.27	16013.50
22	Providing and laying 225 mm dia.salt glazed stone ware pipes including fitting such as bents tees single junction,double junction,laying,jointing (including excavation and refilling the trenches.) complete.				
	(PWD DSR 2015-16 It No 45 c. Page No 136)	1791.33	Rmt	373.30	668704.73
23	Removing from site excavated material lead a) upto 7 Kms.etc.as directed.	4156.96	CuM	432.48	1797800.01
	(PWD DSR 2015-16 It No C1 Page No249)				
24	Removing from site excavated material lead b) upto 10 Kms.etc.as directed.	511.75	CuM	488.79	250136.69
	(PWD DSR 2015-16 It No C1 Page No249)				

Signature of Contractor

No. of Corrections

City Engineer
TMC, Thane

25	Raising and lowering circular manholes to the required levels upto 40cm including all material form work etc.with 20cm thick cement concrete M350 cement concrete coping under frame and cover of manhole including curing etc. complete as specified and as directed. (BMC FMR 2009)	10.00	No	756.00	7560.00
26	Raising and lowering rectangular manholes to required levels upto 40cm including all material form work etc.with 20cm thick cement concrete M350 cement concrete coping under frame and cover of manhole including curing etc. complete as specified and as directed. (BMC FMR 2009)	10.00	No	1626.00	16260.00
27	Providing and Laying in trenches medium grade ISI mark GI pipes with necessary fittings including necessary excavation trench filling applying anti-corrosive paint and two coats of oil paint etc.complete. - 25mm dia (PWD DSR 2015-16 It No 5 B c. Page No 122)	5.00	Rmt	382.84	1914.20
28	Providing and Supplying as per specifications of centrifugally cast (span) Ductile Iron K9 Pressure Pipes (S & S) ISI marked for water conforming to IS 8329/2000 with push on type EPDM 'ISI marked ' rubber gasket jointing as per IS 5382 specifications. 150 mm dia 250 mm dia (MJP DSR-2013-2014, Sec-I- I-3, Pg-72)	5.00 5.00	Rmt Rmt	1333.20 2451.98	6666.00 12259.90
29	Supplying, lowering, laying and jointing DI specials of K-12 class suitable for DI S/S pipes, with external zinc coating and internal Cement Mortar lining, cost of all jointing materials, rubber rings including transportations, freight charges, loading including all taxes etc complete as per IS 9523. A)80 to 300mm dia. (MJP DSR-2013-2014, Sec-I-I-10, Pg-78)	5.00	Kg	118.88	594.40
30	Lowering laying and jointing with SBR ruber gaskets C.I. S/S pipes of various classes with CI / MS specials of following diameter in proper position, grade and alignment as directed by Engineer-in-charge including conveyance of material from stores to site of work, including cost of jointing materials and rubber rings labour, giving hydraulic testing				

Signature of Contractor

No. of Corrections

City Engineer
TMC, Thane

	etc. complete.				
	CI LA class/ DI K-7 & K-9 class				
	150 mm dia	5.00	Rmt	87.77	438.85
	250 mm dia	5.00	Rmt	149.99	749.95
	(MJP DSR-2013-2014, Sec-I- I-2a, Pg-70)				
31	Providing and laying concrete pipes of I.S.NP. class of ----- diameter in proper line, level and slope including necessary collars, excavation, laying, fixing with collars in cement mortar 1:1 and refilling the trench complete.				
a	100 mm	5.00	Rmt	500.56	2502.80
b	150 mm	5.00	Rmt	511.16	2555.80
c	225 mm	5.00	Rmt	563.13	2815.65
d	300 mm	5.00	Rmt	805.98	4029.90
	(PWD DSR 2015-16 It No 46 a b c d. Page No 136)				
32	Providing and laying 150 mm dia.salt glazed stone ware pipes including fitting such as bents tees single junction,double junction,laying,jointing (including excavation and refilling the trenches.) complete.	15.00	Rmt	296.94	4454.10
	(PWD DSR 2015-16 It No 45 b. Page No 136)				
33	Excavation for roadways in soft strata such as earth soil of all sorts,sand, gravel,or soft murum.....including dressingsection to required grade,camber and sides slopes and conveying the excavated materials with all lifts upto lead of 50m and spreading for embankment or stacking, disposing as directed.				
		936.00	CuM	119.84	112170.24
	(PWD DSR 2015-16 It No 3 a I. Page NO 157)				
34	Dismantling Reinforced cement concrete work including breaking concrete by chiselling, wedging etc. including cutting reinforcement,stacking the serviceable materials and debris separately upto a distance of 50m or spreading etc. complete.	120.00	CuM	651.15	78138.00
	(PWD DSR 2015-16 It No 32. Page NO 145)				
35	Providing dry trap rubble stone soling 15-20cm thk including hand packing & compacting etc.				

Signature of Contractor

No. of Corrections

City Engineer
TMC, Thane

	complete.using 80mm metal				
0		150.00	CuM	1394.09	209113.50
	(PWD DSR 2015-16 It No 7 Page No 9)				
36	Providing and laying in situ cement concrete 1:2:4 of trap metal for foundation and bedding including bailing of water manually,formwork compacting and curing etc complete.				
	(PWD DSR 2015-16 It No 1 A ii Page No 16)	222.46	CuM	5758.34	1281017.59
37	Providing and laying in position semi half round pipe embedded in M-20 concrete etc. complete	400.00	Rmt	1706.86	682744.00
	RA				
38	Providing and casting in situ cement concrete of m20 grade of trap / granite /quartzite/ gneiss metal for bed blocks, foundation blocks and such other items including bailing out water formwork, compacting, roughening, them if special finish is to				
	(PWD DSR 2015-16 It No 3 B ii Page No 17)	216.00	CuM	6229.21	1345509.36
39	Providing and casting insitu cement concrete RMC M30 of trap metal for RCC solid slab of all thickness as per drawing including centering, formwork,compacting & roughning the surface if special finish is to be provided & curing (Height upto 5m) etc. complete				
	(PWD DSR 2015-16 It No 4 B c Page No 20)	300.00	CuM	9192.24	2757672.00
40	Providing and fixing in position HYSD bar reinforcement of various dia. for RCC pilecaps,footing,foundation,slab etc. as per detail designs,drawings and schedules including cutting,bending,hooking the bars,binding with wires and tack welding and supporting as required complete.				
	For New Gutter...and For cleaning and recast of slab over gutter	53.40	MT	74403.62	3973153.31
	(PWD DSR 2015-16 It No 10 a Page No 22)				
41	Providing , laying and fixing CPVC pipes of 50 mm dia. with necessary fittings including necessary excavation refilling the trenches etc. complete	5374.00	Rmt	611.91	3288404.34
	(PWD DSR 2015-16 It No 7 f Page No 123)				

Signature of Contractor

No. of Corrections

City Engineer
TMC, Thane

42	Providing and laying SOMANI/PAVIT/ULTRA/VIYARA/ or equivalent make chequered tiles of approved quality of size 30 cm x 30 cm for flooring in required position laid on a bed of 1:4 cement mortar including cement float, filling joint with cement slurry cleaning curing complete. (Specifications: Bd. M. 12 Spec. No.: Bd. M-12 page No. 389)				
	(PWD DSR 2015-16 It No 17 Page No58)	9673.20	m2	955.35	9241291.62
43	Providing and fixing in position Steel fibre reinforced concrete (SFRC) frame and covers of approved make including loading, unloading transportation all taxes etc. complete as directed by Engineer in charge (20 tonnes capacity) Size 90 X 60 cm)				
	(MJP DSR 2012-13 It No 17 d. Page No315)	120.00	No	3169.68	380361.60
44	Providing second class burnt brick masonry with conventional type bricks in CM 1:6 in foundation and plinth,walls including bailing out water manually,striking joints on unexposed faces,raking out joints on exposed				
	(PWD DSR 2015-16 It No 1 Page No26)	259.83	CuM	5407.66	1405072.30
45	Providing second class burnt brick masonry with conventional type bricks in cm 1:6 in superstructure striking joints raking out joints watering scaffolding etc.complete.				
	(PWD DSR 2015-16 It No4. Page No26)	82.80	m3	5478.71	453637.19
46	Providing uncoursed rubble masonry of trap stones in cement mortar in 1 : 6 in foundation including bailing out water manualy,striking joints on unexposed faces and watering complete.				
	(PWD DSR 2015-16 It No 1 Page No29)	16.20	m3	3318.56	53760.67
47	Providing uncoursed rubble masonry of trap stones in cement mortar in 1:6 superstructure including striking joints on unexposed faces and watering etc.complete.				
	(PWD DSR 2015-16 It No 4. Page No29)	5.00	m3	3668.52	18342.60

Signature of Contractor

No. of Corrections

City Engineer
TMC, Thane

48	Providing sand faced plaster externally in cement mortar using approved screened sand, in all positions including base coat of 15 mm thick in cement mortar 1:4 using waterproofing compound at 1 kg per cement bag curing the same for not less than 2 days and keeping the surface of the base coat rough to receive the sand faced treatment 6 to 8 mm thick in cement mortar 1:4 finishing the surface by taking out grains and curing for fourteen days scaffolding etc.complete. Spec. No.: Bd.L.7 Page No. 368				
	(PWD DSR 2015-16 It No 5. Page No 49)	858.00	m2	450.95	386915.10
49	Providing internal cement plaster 20mm thick in two coats in cement mortar 1:5 without neeru finish, to concrete, brick surface, in all positions including scaffolding and curing complete Spec. No.: Bd.L.4 Page No. 365				
	(PWD DSR 2015-16 It No 2 bPage No48)	4907.90	m2	166.01	814760.48
50	Providing and laying ceramic tiles of Somani/RAK/Kajaria / Nitco /Asian or equivalent make of first quality ,having size 30 cm. x 30 cm. for dado and skirting in required position with readymade adhesive mortar of approved quality on plaster of 1:3 cement mortar including joint filling with white/ colour cement slurry cleaning curing complete.				
	(PWD DSR 2015-16 It No 15 a Page No58)	4041.80	m2	1035.60	4185688.08
51	Removing from site excavated material lead a) upto 7 Kms.etc.as directed.				
	(PWD DSR 2015-16 It No C1 Page No249)	1056.00	CuM	432.48	456698.88
52	Providing and laying in situ cement concrete of specified grade of trap / granite /quartzite/ gneiss metal for R.C.C. work in foundations like raft, strip foundations, grillage and footings of R.C.C. columns and steel stanchions etc. including bailing out water, formwork, cover blocks compaction and curing etc. (Excluding reinforcement and structural steel) complete, With.....of grade Spec. No.: Bd.F.3 Page No. 89 Page No.38				
	(PWD DSR 2015-16 It No 1 B bPage No18)	180.00	m2	5918.48	1065326.40

Signature of Contractor

No. of Corrections

City Engineer
TMC, Thane

53	Providing & laying in situ PCC including form work Using Mixer ofGrade, Span length upto 30mtr of trap/granite/quartzite/ gneiss metal for cast in situ piers, abutment, returns, wings etc. including provision of "V" shaped false joints to form suitable panels on the faces to approve design with compacting by vibrating and curing complete, including form work (plywood/steel) centering (excluding dewatering by means of pump) and including bailing out water and curing etc. complete. (upto 5.00 mt. height) Note : add 2% for over 5.00 mt.height increase upto 10.00 mt. and 6% height above 10.00 mt.(height for that particular structure) Spec. No.: BR-24, Page No.-137 MoRT& H,cl. 1500, 1700 & 2200				
	(PWD DSR 2015-16 It No 31 A iibPage No200)	54.00	m2	5588.66	301787.64
54	Dewatering the Excavated Trenches & Pools of Water in the Building Trenches/Pipeline Trenches well works by using pumps & other Devices including disposing off water to safe distance as directed by engineer in charge.				
	(MJP 13-14 It No 16 Page No 40)	500.00	BHPper hr	66.66	33330.00
55	Providing and Constructing Cofferdam in River Basin, Dam Storage as per Type Design including excavation , Filling the middle portion with B. C. Soil (in Gunny Bag if Required) providing impervious/semipervious material on both side of B.C. Soil (in Gunny Bag if Required) including ramming, compating to the satisfaction of Engineer in charge till the completion of work including dismantling cofferdam after completion of work & disposing of the material as directed byEngineer in charge				
	(MJP 13-14 It No 1Page No 317)	135.00	CuMt	594.39	80242.65
56	Drilling of Borewell upto 300 ft and Installation of 5 HP Submersible Pump	8.00	No.	150000.00	1200000.00
	Approved Rate				
57	Installing And Assembling Drip Irrigation System				
	Approved Rate	5470.50	Sqm	60.00	328230.00
58	Providing and Laying in trenches 15mm dia CPVC pipe of Prince/Sudhakar/Kishan/				

Signature of Contractor

No. of Corrections

City Engineer
TMC, Thane

	Suprem or equivalent make including necessary excavation trench filling refitting trenches etc.complete				
	(PWD DSR 2015-16 It No 7 a Page No123)	2887.00	Rmt	177.10	511297.80
59	Providing and Laying in trenches 20 mm dia CPVC pipe of Prince/Sudhakar/Kishan/Suprem or equivalent make including necessary excavation trench filling refitting trenches etc.complete				
	(PWD DSR 2015-16 It No 7 b Page No123)	2887.00	Rmt	207.86	600086.05
60	Providing and Laying in trenches 25 mm dia CPVC pipe of Prince/Sudhakar/Kishan/Suprem or equivalent make including necessary excavation trench filling refitting trenches etc.complete				
	(PWD DSR 2015-16 It No 7 c Page No123)	2887.00	Rmt	261.94	756230.88
61	Providing sculpture on wall	201.43	Sft	5000.00	1007150.00
	RA				
62	Providing and Applying Vinayal Painting including Scaffolding , preparing the etc . Complete	120.00	m2	2044.40	245328.00
	RA				
63	Providing second class burnt brick masonry with conventional type bricks in cm 1:6 in superstructure striking joints raking out joints watering scaffolding etc.complete.				
	(PWD DSR 2015-16 It No 4 Page No 26)	3.45	m3	5478.71	18901.55
64	Providing internal cement plaster 20mm thick in two coats in cement mortar 1:5 without neeru finish, to concrete, brick surface, in all positions including scaffolding and curing complete Spec. No.: Bd.L.4 Page No. 365				
	(PWD DSR 2015-16 It No 2 b Page No 48)	37.50	m2	166.01	6225.38
65	Providing and laying ceramic tiles of Somani/RAK/Kajaria / Nitco /Asian or equivalent make of first quality ,having size 30 cm. x 30 cm. for dado and skirting in required position with readymade adhesive mortar of approved quality on plaster of 1:3 cement mortar including joint filling with white/ colour cement slurry cleaning curing complete.				
	(PWD DSR 2015-16 It No 15 a Page No58)	37.50	m2	1035.60	38835.00

Signature of Contractor

No. of Corrections

City Engineer
TMC, Thane

66	Graden Soil :- Supplying on site garden soil well sieved 90% to pass through I.S. sieve of 10mm size free from stones rubbish like dried grass roots and other such materials. The soil Should be fresh from quarry. The colour of the soil generally be red. The soil will be measured by measuring box. (Farma)				
	(Park & Garden SOR 2012-13 It No 1 Page No3)	1448.33	Cum	710.00	1028314.30
67	Fram Yard Manure : Supplying on site well decayed, well dried, well powdered, without clods and free from stones, dried grass and other fubbish material. The colour of the manure generally be black. The manure will be measured by measuring box. (Farma)				
	(Park & Garden SOR 2012-13 It No 2 Page No3)	1448.33	Cum	725.00	1050039.25
68	Mixing garden soil/Silt & manure thoroughly well, watering previous night. Planting required plant species, lawn grass as directed etc. complete (1/10 of Semiskilled labour)				
	(Park & Garden SOR 2012-13 It No 3 Page No2)	2896.65	Cum	45.00	130349.25
69	Filling fresh garden soil / silt & manure in excavated area including lead upto a distance of 50 Mtrs.				
	(Park & Garden SOR 2012-13 It No 2 Page No2)	2896.65	Cum	30.00	86899.50
70	Preparing instant lawn : Excavation the ground to a required depth of 20 cms, removing & conveying unwanted stuff to a required distance as directed. Filling fresh garden soil/silt & manure in excavated area in 3:1 proportion to a height of 20cms. Mixing garden soil and manure thoroughly, well, levelling, watering on previous night Planting required variety of lawn grass as directed and maintining till well established by watering weeding, clipping, rolling, etc. complete.				
		2365.00	Sqm	679.00	1605835.00
	(Park & Garden SOR 2012-13 It No 3 Page No6)				

Signature of Contractor

No. of Corrections

City Engineer
TMC, Thane

71	Preparing Shrubbery : Excavation the ground to a required depth of 30 cms, removing & conveying unwanted stuff to a required distance as directed. Filling fresh garden soil/silt & manure in excavated area in 3:1 proportion to a height of 30cms. Mixing garden soil and manure thoroughly, well, levelling, watering on previous night Planting well-developed shrubs plants 0.5 m apart as directed and maintaining till well established by watering weeding, clipping, rolling, etc. complete.				
	(Park & Garden SOR 2012-13 It No 8 Page No 7)	5680.50	Sqm	588.00	3340134.00
72	Providing and fixing Palm tree	200.00	no	3000.00	600000.00
	(Park & Garden SOR 2012-13 It No 2 C Page No 5)				
73	Providing and fixing Sapling of small & medium ornamental flowering plant , Thuja, Cupresus , Ornamental Ficus Mussanda etc.	10000.00	no	50.00	500000.00
	(Park & Garden SOR 2012-13 It No 11 Page No 4)				
74	Mogra Plant/ Creepers/ Climbers : Excavating pit with size 0.3 X 0.3 X 0.3 m t, Removing and conveying unwanted stuff to a required distance as directed . Filling the pit with approved excavated material upto height of .15 m and remainig ht of .15 m with fresh garden soil and manure in 3: 1 proportion .Mixing garden soil and manure thoroughly, well, levelling, watering on previous night Planting well-developed shrubs plants 0.5 m apart as directed and maintaining till well established by watering weeding, clipping, rolling, etc. complete.	10000.00	no	161.00	1610000.00
	(Park & Garden SOR 2012-13 It No 10 Page No 8)				
75	Preparing Flower Bed : Excavation the ground to a required depth of 30 cms, removing & conveying unwanted stuff to a required distance as directed. Filling fresh garden soil/silt & manure in excavated area in 3:1 proportion to a height of 30cms. Mixing garden soil and manure thoroughly, well, levelling, watering on previous night Planting seedlings of required annuals 25 cms apart maintaining till well established by watering weeding, strring,replacing casualties etc. complete.	1000.00	Sqmt	613.00	613000.00
	(Park & Garden SOR 2012-13 It No 6 Page				

Signature of Contractor

No. of Corrections

City Engineer
TMC, Thane

	No 7)				
76	Plants Required for Landscaping (Euphorbia, Hemelia, Maphegia, Mussanda, Ticona, Song of India, Golden Bamboo, Buddhas Bamboo, Golden Ficus, Phonicus Palm, X mas Tree, Tricus Opanda Etc. (Park & Garden SOR 2012-13 It No 6 Page No 7)	10000.00	no	275.00	2750000.00
77	Providing and Applying teo coats of Apex Ace exterior paint of approved manufacture and of approved colour to the plastered surfaces including cleaning, preparing the p[aster surface , applying primer coat , scaffolding if necessary , and watering the surface for two days complete. (PWD DSR 2015-16 It No 16 Page No 73)	100.00	Sqmt	134.68	13468.00
78	Providing and Applying teo coats of Apex Ace exterior paint of approved manufacture and of approved colour to the plastered surfaces including cleaning, preparing the p[aster surface , applying primer coat , scaffolding if necessary , and watering the surface for two days complete. (PWD DSR 2015-16 It No 16 Page No 73)	100.00	Sqmt	134.68	13468.00
79	P/F Spot Light with all Electrical Accessory Including all fittings 3core 4sqmm copper conductor wire etc complete	170.00	no	4520.00	768400.00
80	Supply, Erection, Testing and Commissioning of street light control panel as per specification including GI Sheet 1.6 mm (16 guage) fibre panel box as per directed, Iron work for panel board or other purposes with bending, cutting, drilling & welding eith duly panted, one coat of red oxide and two coats of enamel paint, Providing cement concrete for foundation or for concrete filling in 1:3:6 ratio with 20 to 25 mm stone metal duly plastered with necessary curing for pole muffing, S & P Triple pole iron clad H.C. type rewirable fuse and switch 415/500 V, 63 A with neutral link, S & E 63A fuse bridges of 9 Nos., 100 A fuse bridges of 4 Nos., S,E,T & C of nature switch infrared for making ON/OFF street light as per sun rise and sun set. The nature switch shall be housed in FRP casing with protection MCB with opening voltage 150 V to 300 V, S & E 4 Pole power contactor of 440 V, 40A 3 Nos., S & E copper strip of required sizes used for earthing, S & E	12.00	no	300620.00	3607440.00

Signature of Contractor

No. of Corrections

City Engineer
TMC, Thane

	Galvanised cast iron earth plate size 60 x 60 x 0.6 cm of 2 Nos., S & E 500 V 63 A porcelain base neutral link and S & E mains with 2 x 6 sqmm and earth wire 4 Sqmm FR PVC Copper wire for panel wiring, S & E 3 1/2 x 50 Sqmm Armoured Aluminium conductor cable up to 100 Meter, DWC Pipe for cable, Reimbursement for providing 3 Phase MSEB Connection for panel after submission of receipt by MSEB.				
	4 Meter Ht Single Bracket				
81	Supplying and erecting approved type LED round decorative light fitting above 36 to 48W, having PF > 0.95, class IP 65 or above. Housing of pressure die cast aluminium alloy and heat sink extruded aluminium as per shape & size directed by Engineer In Charge	340	Each	15743.00	5352620.00
82	Supplying & erecting PVC armoured cable 4 core 10 Sq. mm. stranded/solid aluminium conductor complete erected with glands & lugs, on wall/ trusses/pole or laid in provided trench/ pipe as per specification no. CB-LT/AL	8500	rmt	171.00	1453500.00
83	Supplying and laying (including excavation) 50 mm outside dia. double wall corrugated pipes (DWC) of HDPE for enclosing cable below ground/road surface, to required depth complete.	6800	Each	184.00	1251200.00
84	Providing & erecting PU painted 4 m high (clear height) decorative pole with foundation bolts on provided foundation as per specification	340	Each	14875.00	5057500.00
85	Providing & casting of M- 20 grade reinforced cement concrete (RCC) foundation suitable for 3m to 5m high octagonal / conical G.I. pole considering the safe soil bearing capacity at site as 10 T/sq m at 1.5 m depth including supply of steel, concrete, exc	340	Each	3668.00	1247120.00
86	Supplying and erecting pipe type earthing with 40mm. dia. G.I. pipe or 20 mm dia. G.I. strip complete with all materials as per specification no. EA-EP	340	Each	1536.00	522240.00

Signature of Contractor

No. of Corrections

City Engineer
TMC, Thane

87	Supplying & erecting mains with 3x2.5 Sq.mm F.R stranded/solid copper PVC insulated wire laid in provided conduit/trunking/inside pole/Bus bars or any other places as per specification No: WG- MA/BW	1360	rmt	76.00	103360.00
88	Supplying, erecting & marking SPMCB 0.5A to 5A in provided distribution board as per specification no.CB-SB	340	Each	244.00	82960.00
	7 Meter Ht Single Bracket				
90	Providing & erecting 7 m high (clear height) galvanised OCTAGONAL pole with foundation bolts having bottom of 155 mm A/F, top 70 mm A/F on provided foundation as per specification No.OH-PL/OPL	6	Each	22000.00	132000.00
91	Supplying and erecting Street light bracket for erection of double fitting made from 40 mm. dia 'B' class G.I. pipe 1.0 m in length along with pole cap of 300 mm length 100 mm dia duly welded as per specification no. FG-BKT/BPC	6	Each	6000.00	36000.00
92	Supplying and erecting LED flood light fitting 120W to 150W, having PF > 0.95, class IP65 or above. Housing of pressure die cast aluminium alloy and heat sink extruded aluminium as per specification no. FG-ODF/FLS2	6	Each	27571.00	165426.00
93	Supplying and laying (including excavation) 50 mm outside dia. double wall corrugated pipes (DWC) of HDPE for enclosing cable below ground/road surface, to required depth complete.	150	mtr	184.00	27600.00
94	Supplying, erecting & terminating PVC armoured cable 4 core 16 sq mm aluminium conductor with continuous 5.48 sq mm (12 SWG) G.I. earth wire complete erected with glands & lugs, on wall/ trusses/pole or laid in provided trench/ pipe as per specification no. CB-LT/AL	180	mtr	195.00	35100.00
95	Supplying & erecting mains with 2x6 sq.mm F.R copper PVC insulated wire laid in provided conduit/trunking/inside pole/Bus bars or any other places as per specification No: WG-MA/BW	144	mtr	105.00	15120.00

Signature of Contractor

No. of Corrections

City Engineer
TMC, Thane

96	Supplying and erecting aluminium strip of required sizes used for earthing on wall and/or any other purpose with necessary aluminium clamps fixed on wall painted with bituminous paint in an approved manner with joints required. as per specification No (EA-EP).	6	Kg	865.00	5190.00
97	Providing pipe type earthing with 40mm. dia. G.I. pipe or 20 mm dia. G.I. Rod complete with all materials as per specification No. EA-EP	6	Each	1536.00	9216.00
98	Providing & casting of M- 20 grade reinforced cement concrete (RCC) foundation suitable for 9m & 10m high octagonal /conical G.I. pole considering the safe soil bearing capacity at site as 10 T/sq m at 1.5 m depth including supply of steel, concrete, excavation and fixing provided nut bolts with the help of template as per design in an approved manner.	6	Each	8006.00	48036.00
	9 mtr Double Bracket (Median)				
99	Providing & erecting 9 m high (clear height) galvanised OCTAGONAL pole with foundation bolts having bottom of 155 mm A/F, top 70 mm A/F on provided foundation as per specification No.OH-PL/OPL	4	Each	25000.00	100000.00
100	Supplying and erecting Street light bracket for erection of double fitting made from 40 mm. dia 'B' class G.I. pipe 1.0 m in length along with pole cap of 300 mm length 100 mm dia duly welded as per specification no. FG-BKT/BPC	4	Each	9000.00	36000.00
101	Supplying and erecting LED flood light fitting 120W to 150W, having PF > 0.95, class IP65 or above. Housing of pressure die cast aluminium alloy and heat sink extruded aluminium as per specification no. FG-ODF/FLS2	8	Each	27571.00	220568.00
102	Supplying and laying (including excavation) 50 mm outside dia. double wall corrugated pipes (DWC) of HDPE for enclosing cable below ground/road surface, to required depth complete.	100	mtr	184.00	18400.00

Signature of Contractor

No. of Corrections

City Engineer
TMC, Thane

103	Supplying, erecting & terminating PVC armoured cable 4 core 16 sq mm aluminium conductor with continuous 5.48 sq mm (12 SWG) G.I. earth wire complete erected with glands & lugs, on wall/ trusses/pole or laid in provided trench/ pipe as per specification no. CB-LT/AL	120	mtr	195.00	23400.00
104	Supplying & erecting mains with 2x6 sq.mm F.R copper PVC insulated wire laid in provided conduit/trunking/inside pole/Bus bars or any other places as per specification No: WG-MA/BW	96	mtr	105.00	10080.00
105	Supplying and erecting aluminium strip of required sizes used for earthing on wall and/or any other purpose with necessary aluminium clamps fixed on wall painted with bituminous paint in an approved manner with joints required. as per specification No (EA-EP).	4	Kg	865.00	3460.00
106	Providing pipe type earthing with 40mm. dia. G.I. pipe or 20 mm dia. G.I. Rod complete with all materials as per specification No. EA-EP	4	Each	1536.00	6144.00
107	Providing & casting of M- 20 grade reinforced cement concrete (RCC) foundation suitable for 9m & 10m high octagonal /conical G.I. pole considering the safe soil bearing capacity at site as 10 T/sq m at 1.5 m depth including supply of steel, concrete, excavation and fixing provided nut bolts with the help of template as per design in an approved manner.	4	Each	8006.00	32024.00
108	P/L of hot applied White thermo plastic compound 2.5 mm thk.,traffic lane edge/centre line strips 10 cm wide including reflectorising glass beads etc. complete. (PWD DSR 2015-16 It No 60A Page No176)	1154.80	Sqmt	1166.55	1347131.94
109	P/L of hot applied Yellow thermo plastic compound 2.5 mm thk.,traffic lane edge/centre line strips 10 cm wide including reflectorising glass beads etc. complete. (PWD DSR 2015-16 It No 60B Page No176)	1732.20	Sqmt	1224.88	2121737.14

Signature of Contractor

No. of Corrections

City Engineer
TMC, Thane

110	Providing and Fixing of Retro Reflectorised 600mm Cautionary sign boards made out of retro reflective sheeting of High Intensity prismatic grade conforming to IRC-67: 2012 & Type IV standards of ASTM D4956-09 specifications, fixed over 2 mm thick Al / 4mm thick ACP sheet supported with Back support frame of 25x25x3mm mild steel angle as approved , supported on a mild steel angle iron post 75 mm X 75 mm X 6 mm - 3.5 mtr height, firmly fixed to the ground by means of properly designed foundation with M20 grade cement concrete 45 cm X 45 cm X 60 cm , 60 cm below ground level as per approved drawing. 7 years Warranty for Retro Reflective Sheeting from the original sheeting manufacturer & a certified copy of three years outdoor exposure report from an independent test lab for the product offered shall be submitted by the contractor Mandatory boards of 60 cm Diameter. Spec. No.: IRC-67 of 2012 (PWD DSR 2015-16 It No 52Page No171)	40.00	No	4168.83	166753.20
111	Providing and Fixing of Retro Reflectorised 900mm Cautionary sign boards made out of retro reflective sheeting of High Intensity prismatic grade conforming to IRC-67: 2012 & Type IV standards of ASTM D4956-09 specifications, fixed over 2 mm thick Al / 4mm thick ACP sheet supported with Back support frame of 25x25x3mm mild steel angle as approved , supported on a mild steel angle iron post 75 mm X 75 mm X 6 mm - 3.5 mtr height, firmly fixed to the ground by means of properly designed foundation with M20 (PWD DSR 2015-16 It No 53Page No171)	17.28	No	4729.83	81731.46
112	Providing and Fixing of Retro Reflectorised direction & place identification sign boards made out of retro reflective sheeting of High Intensity prismatic grade conforming to IRC-67: 2012 & Type IV standards of ASTM D4956-09 specifications, fixed over 2mm thick Al / 4 mm thick ACP sheet supported with Back support frame of 35x35x5mm mild steel angle with areas not exceeding 0.9 sqm. Supported in mild steel angle iron post 75x75x6mm - 3.5 mtr height ,firmly fixed to the ground by means of properly designed foundation of M20 grade cement concrete 45 cm X 45 cm X 60 cm , 60 cm below ground	8.00	SqMt	9691.91	77535.28

Signature of Contractor

No. of Corrections

City Engineer
TMC, Thane

	level complete (as per MoRT&H specification No.801) (for area Less than 0.9 sqm). 7 years Warranty for Retro Reflective Sheeting from the original sheeting manufacturer & a certified copy of three years outdoor exposure report from an independent test lab for the product offered shall be submitted by the contractor. Direction Sign boards below 0.9 Sq.Mtr Spec. No.: IRC-67 of 2012				
	(PWD DSR 2015-16 It No 54Page No172)				
113	Providing and Fixing of Retro Reflectorised direction & place identification sign boards made out of retro reflective sheeting of High Intensity prismatic grade conforming to IRC-67: 2012 & Type IV standards of ASTM D4956-09 specifications, fixed over 2mm thick Al / 4 mm thick ACP sheet supported with Back support frame of 35x35x5mm mild steel angle with areas not exceeding 0.9 sqm. Supported in mild steel angle iron post 75x75x6mm - 3.5 mtr height & with MS angle of 50x50x5mm bracing,firmly	8.00	SqMt	11644.29	93154.32
	(PWD DSR 2015-16 It No 55Page No172)				
114	Supplying & Fixing of Molded Shank Raised Pavement Markers made of polycarbonate and ABS moulded body and reflective panels with micro prismatic lens capable of providing total internal reflection of the light entering the lens face and shall support a load of 16000 kg tested in accordance to ASTM D 4280 Type H and complying to Specifications of Category A of MORTH Circular No RW/NH/33023/10-97 – DO III Dt 11.06. 1997. The height, width and length shall not exceed 50 mm, 100 mm and 102 +/- 2 mm and with minimum reflective area of 13 Sqcm on each side and the slope to the base shall be 35 +/- 5 degree. The strength of detachment of the integrated cylindrical shanks, (of diameter not less than 19 +/- 2 mm and height not less than 30+/- 2 mm) from the body is to be a minimum value of 500 Kgf. Fixing will be by drilling holes on the road for the shanks to go inside, without nails and using epoxy resin based adhesive as per manufacturer's recommendation and complete as directed by the engineer. Twin Shank RPM (Cat Eye)	1000.00	No	676.60	676600.00

Signature of Contractor

No. of Corrections

City Engineer
TMC, Thane

	Spec. No.: As directed by Engineer-in-charge				
	(PWD DSR 2015-16 It No 59Page No175)				
115	Providing and painting zebra painting of pedestrain crossing on the carrigeway with approved road making paint in two coats etc. complete.(over 10cm.wide patta) Spec. No.: MORTH 803	1629.00	m2	69.99	114013.71
	(PWD DSR 2015-16 It No 62 a. Page No176)				
116	Providing & fixing Ice Cream/ Trunk / Puppy dust bins(as directed by engineer incharge)	20.00	No.	30448.00	608960.00
	(BMC SOR 2013 Me 15-1 md/me/mf Pg No 135)				
117	Providing nd fixing overhead cantilever sign boards of size 3.00 m x 1.5 m made up of 4.00mm thk ACP sheet of ALICOBOND / ALBOND or equivalent make fixed on m. s. angle frame of 35x35x2 mm painted with hot Deep Galvanising (Zink) process 75 micron thickness having minimum life of 15 years , the reflective sheeting should be of 3M prismatic grade make nd should have reflection on its entire surface. The whole assemble should be fixed with nut , bolt, buffer on M.S. pipe of 300 mm dia at an height of 6.00m hig h have base plate 20 mm thk ,stiffened with 10 mm M.S.plate and anchored with foundation by 20.00 dia anchor bolt to Foundation .All works should be carried as per drawing attached and instruction given by engineer incharge .The item includes all taxes and duties like vat insurance octroi labour welfare etc. complete.	6.00	no	164788.00	988728.00
	RA				
118	Garden light luminaire type bollard suitable for PLS lamp along with gear unit and 1 No. PLS 9 W lamp.	24.00	no	4561.00	109464.00

Signature of Contractor

No. of Corrections

City Engineer
TMC, Thane

	(BMC SOR 2013 Me 4-10m f Pg No 69)				
119	Providing & fixing decorative benches.	10.00	No.	17050.00	170500.00
	(MSSIDC Rate 2010-11 It No 106 Page No 4)				
120	Providing Structural steel work in trusses and other similar trusses purlins and members with all bracings gusset plates etc. as per drawing or as directed including cutting fabricating hoisting,erecting,fixing in position making riveted/bolted /welded connections and one coat of anticorrosive paint and over it two coats of oil paint etc.complete.	0.50	MT	71814.94	35907.47
	(PWD DSR 2015-16 It No1 Page No14)				
121	Providing, Supplying ,Installation & Commissioning of 2 Unit Etoilet & 1 Bio Digester of 2 Cum Capacity with all fitting & Fixture including One Year Maintainance etc Complete	3.00	no	1641682.00	4925046.00
	RA				
122	P/F Bus stop shelter made up of Stainless Steel Material , Fixing in M-20 Concrete having 100 mm dia. And 3.00 mm thk pipe of 4.00 mtr ht. , Covered with Heavy Duty Polycarbonate Sheet (5.00 mm Thk) as per Design and drawing having Advertisement post of size 7 X 1.5 m & 1.5m X 2.0m size etc. complete.	8.00	no	405000.00	3240000.00
	MR				
123	Removing rich mix cement concrete including stacking the spoils as directed with lead and lift etc complete.	12.0	m3	423.14	5077.68
	(PWD DSR 2015-16 It No 13 Page No143)				
124	Removing cement tiles or marble or polished shahabad floor or dado without bed concrete including stackin the materials as directed with all leads, lifts etc.	40.0	m2	21.21	848.40
	(PWD DSR 2015-16 It No 23 Page No144)				
125	Dismantking brick masonry in lime or cement including stacking the spoils as directed with lead and lift etc complete.	12.0	m3	148.47	1781.64
	(PWD DSR 2015-16 It No 9 Page No142)				
126	Dismantking stone masonry in mud and stacking the material as directed with lead and lift etc complete.	12.0	m3	171.80	2061.60

Signature of Contractor

No. of Corrections

City Engineer
TMC, Thane

	(PWD DSR 2015-16 It No11 Page No143)				
127	Excavation for foundation/pipe trenches in ash muddy/ marshy/ slushy/soil incld. Use of poclain, labour for dewatering during execution incld. Removing the excavated material upto a distance of 50 m & lifts as below, stacking & spreading as directed, preparing the bed by cleaning the mud, labour required for excluding backfilling etc. complete. Providing & fixing shuttering shall be paid separately.	12.0	m3	334.41	4012.92
	(MJP DSR 2013-14 It No 10. Page No38)				
128	Providing and laying C.C.pipes of ISNP2 class of 300mm dia in proper line level and slope including necessary collars,excavation, laying fixing with collars in cement mortar 1:1 and refilling the trench complete.	10.0	Rmt	805.98	8059.80
	(PWD DSR 2015-16 It No 46 d Page No136)				
129	Providing and fixing in position Steel fibre reinforced concrete (SFRC) frame and covers of approved make including loading, unloading transportation all taxes etc. complete as directed by Engineer in charge (20 tonnes capacity)				
a	540 mm dia	10.0	No	2925.26	29252.60
b	560 mm dia	10.0	No	4030.71	40307.10
c	90X 45 cm size	10.0	No	2925.26	29252.60
d	90X 60 cm size	11.0	No	3169.68	34866.48
e	60X 60 cm size	10.0	No	2895.27	28952.70
f	60 X 45 cm size	10.0	No	2508.64	25086.40
	(MJP DSR 2013-14 It No 17. Page No315)				
130	Providing and constructing brick masonry inspection chambers 90 x 45 cm and 60 cm in depth including 1:2:4 cement concrete channels half round stoneware pipes brick masonry plastering in cement mortar 1 : 3 from inside and cast iron lid with frame fixing cement concrete etc. complete.	10.0	No	6366.18	63661.80
	(PWD DSR 2015-16 It No 47 A i. Page No136)				
131	P/L in situ cement concrete M25 of trap metal for RCC raft including bailing of water manually, formwork, compacting & curing.	1.5	m3	6259.96	9389.94
	(PWD DSR 2015-16 It No 1 A b Page No18)				

Signature of Contractor

No. of Corrections

City Engineer
TMC, Thane

132	P/L insitu cement concrete M25 of trap metal for RCC abutments including bailing of water manually, formwork, compacting & curing. (PWD DSR 2015-16 It No 2 A b Page No18)	1.5	m3	8457.32	12685.98
133	P/A two coats of flat oil paint to plastered surface--- etc.complete. (PWD DSR 2015-16 It No 7. Page No71)	240.0	m2	61.51	14762.40
134	Providing railing of mild steel angle post 2M center to center of section 75mm x 75mm x 10mm or equivalent I/ channel section of height 1.05 above bridge surface with minimum anchor length of 30cm including hold fast of 25mm dia. M.S. bar welded at the bottom and concreting of 1:3:6 of size 30cm x 30cm x 30cm with three rows of 40mm B class G.I. pipe provided at 30 on center to center including scaffolding and with one coat of anticorrosive paint and over it two coats of oil painting, curing of concrete etc. complete. (PWD DSR 2015-16 It No 69Page No216)	10.0	Rmt	2719.12	27191.20
135	Supply of excavator cum loader machine (like JCB machine) etc complete for 8 Hours (MJP DSR 2013-14 It No 13. Page No 13)	50.0	Hr	1166.55	58327.50
136	Total station survey of existing compound area showing existing plot boundry, structure, electric poll, manhole, chamber, trees location details adjoining roads etc. Preparing detailed Plans of road including proper file including colouring prints of plans, indexing and paging, with all types of compliance, if required from department etc.complete with before and after work Providing '7' copies of computer printouts of plans duly bound in the form of booklet.Spec. As directed by Engineer in charge. (PWD DSR 2015-16 It No 22 Page No244)	70731.5	Sqm	6.36	449852.34

Rs. 143311993.46

Say Rs. 143311000.00

Signature of Contractor

No. of Corrections

City Engineer
TMC, Thane

Thane Municipal Corporation, Thane	
Public Works Department	
Subject :- Estimate and Scope For Maintenance of Kolshet Road From Nandi Baba To Devshree Park for 3 year tenure.	
Sr. No.	Description of Work
Civil Works	
1	Repair and replacment of Divider stones
2	Repair and replacment of Kerb Stones
3	Repair and replacment of Water table
4	Repair and replacment of M.S.Grill
5	Repair and res-storation of road patch by Metaling 100 mm. thick, PCC of M-10 by 75 mm thick, CC pavement of M-20 of 75 cm thick including curing etc.
6	Repair and res-storation of foothpath patch CC pavement of M-20 including curing etc.
7	Providing new storm drain cover / replacing storm drain cover , MTNL , Sewer,or any other cover
8	Painting Divider stones every after 3 months or as directed.
9	Painting Kerb stones every after 3 months or as directed.
10	Painting by whitewash and red colour and trimming road side trees every after 3 months or as directed.
11	Thermoplastic lane marking to total road once in year.(yellow)
12	Thermoplastic lane marking to total road once in year.(white)
13	Washing and cleaning Divider once in month
14	Washing and cleaning Kerb stones once in month
15	Cleaning drainholes once in month
16	Cleaning storm drain and chambers once in year before mansoon
17	Cleaning of Gantry and all Sign boards shall be carry out regularly
18	Maintaining Bio toilet clean and usable all time by cleaning with detergent, keeping liquid soap, air freshner etc.
19	Debris on road shall be removed and transported
Gardening Work	
1	Watering ,Cleaning, Manuaring,Trimming and Replacing dead Grass and keeping all time Green Grass lawns including motor repair etc..
2	Watering ,cleaning and replacing dead shurbs
Electric Work	
1	Painting to street light poles and their brackets once in year.
2	Replacing brocken / dead bulbs .
3	Cleaning and Painting to MSEDCL, MTNL feed/ control boxes

Signature of Contractor

No. of Corrections

City Engineer
TMC, Thane

Statement showing approximate Income through Pay and Park							
	<u>Assumptions</u>						
	<u>For</u>	<u>Repetations</u>					
1	Two wheeler (every 2 hours= 1 round)	6	Note:-				
2	Four wheeler light vehicle	3	1.Rates of Parking taken as per G.B. Resolution No 122 dt 08.09.2015				
3	Four wheeler Heavy vehicle	4	2.Parking Slots Numbers are as per approval G.B. Resolution No 7 dt 17.4.2013				
4	Three wheeler	Rs.500/- per month for all grade of roads					
Sr.No	Name of Model Rd	Parking repetations	Parking Slots			Parking Hours Per Day	Parking Charge
			Left	Right	Total	Hours	Rs.
1	2	3	4	5	6	$7 = 3 \times 6$	8
1	Kolshet Rd- Grade B	B					
	Two Wheeler Parking	6			57	342	10.00
	Two Wheeler Parking night	1			57	57	10.00
	Three Wheeler Parking Monthly	0			0	0	500.00
	Four Wheeler Parking Dilaly	2			35	70	25.00
	Four Wheeler Parking Dilaly Night	1			35	35	25.00
	Four Wheeler Parking Monthly	1			30	30	750.00
	Four Wheeler Commercial Parking Night monthly	1			10	10	1500.00

Signature of Contractor

No. of Corrections

City Engineer
TMC, Thane

XII
Drawings

Signature of Contractor

No. of Corrections

City Engineer
TMC, Thane

300 CM x 150 CM



Signature of Contractor

No. of Corrections

City Engineer
TMC, Thane

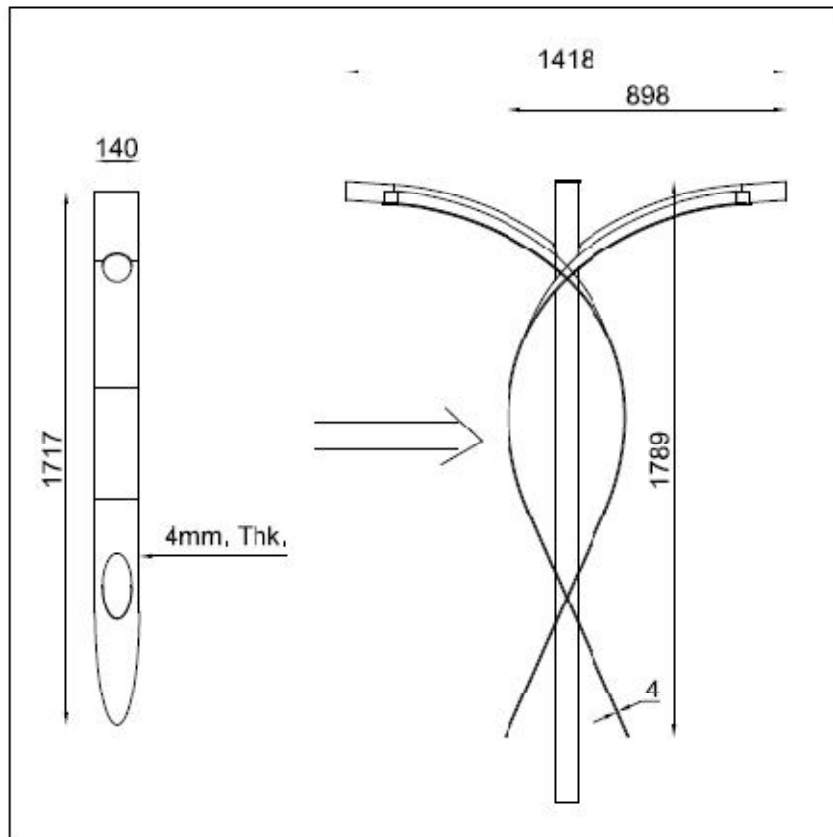
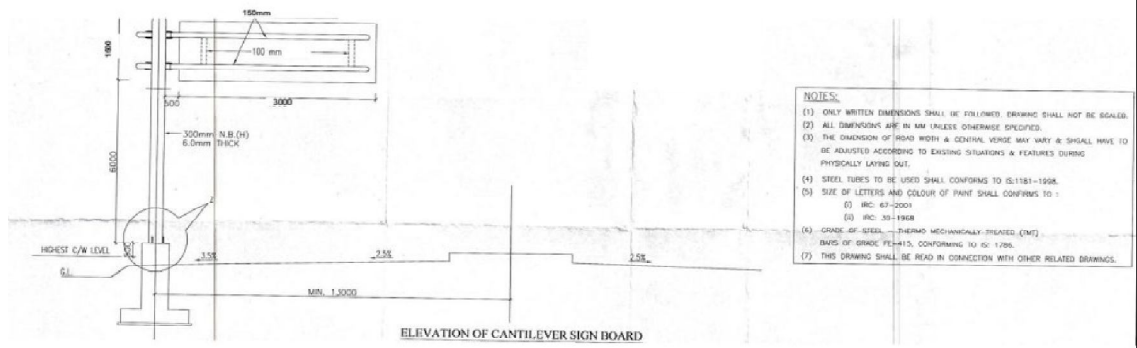

Signature of Contractor

No. of Corrections

City Engineer
TMC, Thane

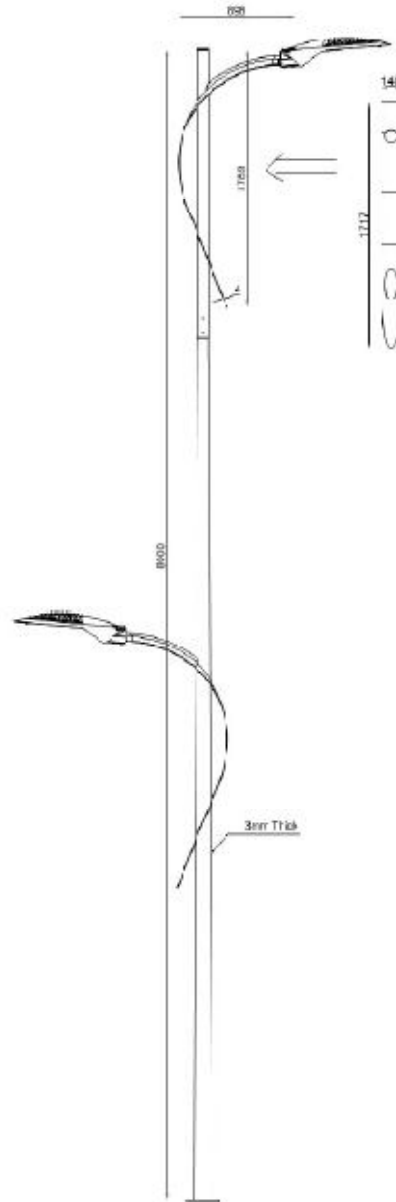
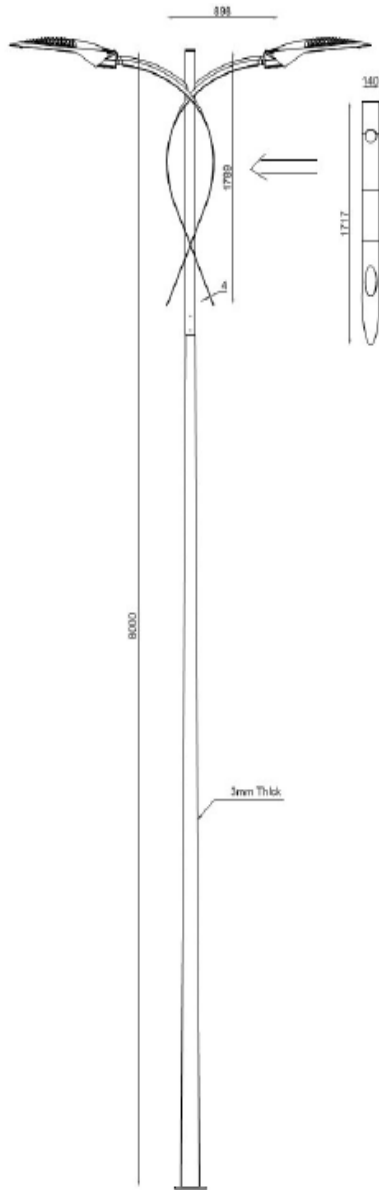

Signature of Contractor

No. of Corrections

City Engineer
TMC, Thane

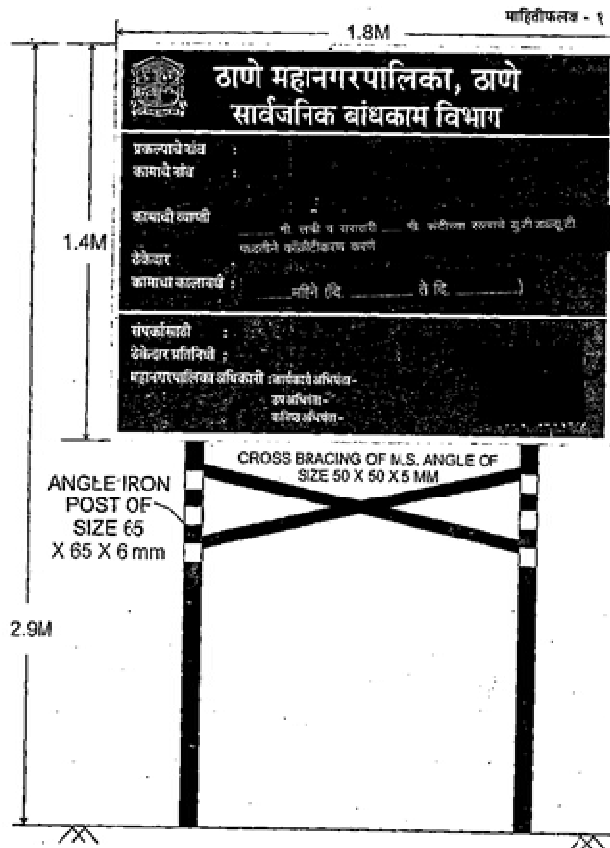

Signature of Contractor

No. of Corrections

City Engineer
TMC, Thane

माहितीफलक - २



ठाणे महानगरपालिका, ठाणे
सार्वजनिक बांधकाम विभाग

- पुढे २०० मीटर अंतरावर रस्त्याचे काम सुरु आहे.
- कृपया वाहने हळू चालवा व वाहतूक नियमाचे पालन करून महानगरपालिकेस सहकार्य करा.
- असुविधेबाबत दिलगीर आहोत.

1.2 M

WHITE COLOUR
ANGLE IRON
POST OF
SIZE 50 X 50 X 5

BOARD SIZE 1 M X 1 M

माहितीफलक - ४



ठाणे महानगरपालिका, ठाणे
सार्वजनिक बांधकाम विभाग

रस्त्याचे काम सुरु आहे
कृपया सावकाश जावे

**GO SLOW
WORK IN
PROGRESS**

1.2 M

WHITE COLOUR
ANGLE IRON
POST OF
SIZE 50 X 50 X 5

BOARD SIZE 1 M X 1 M

Signature of Contractor

No. of Corrections

City Engineer
TMC, Thane

माहितीफलक - ५

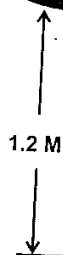

WHITE COLOUR
ANGLE IRON
POST OF
SIZE 50 X 50 X 5

SIZE 60 CM CIRCLE

Signature of Contractor

No. of Corrections

City Engineer
TMC, Thane

माहितीफलक - ६



1.2 M

WHITE COLOUR
ANGLE IRON
POST OF
SIZE 50 X 50 X 5

SIZE 60 CM

Signature of Contractor

No. of Corrections

City Engineer
TMC, Thane

सुरक्षा साधन - ७

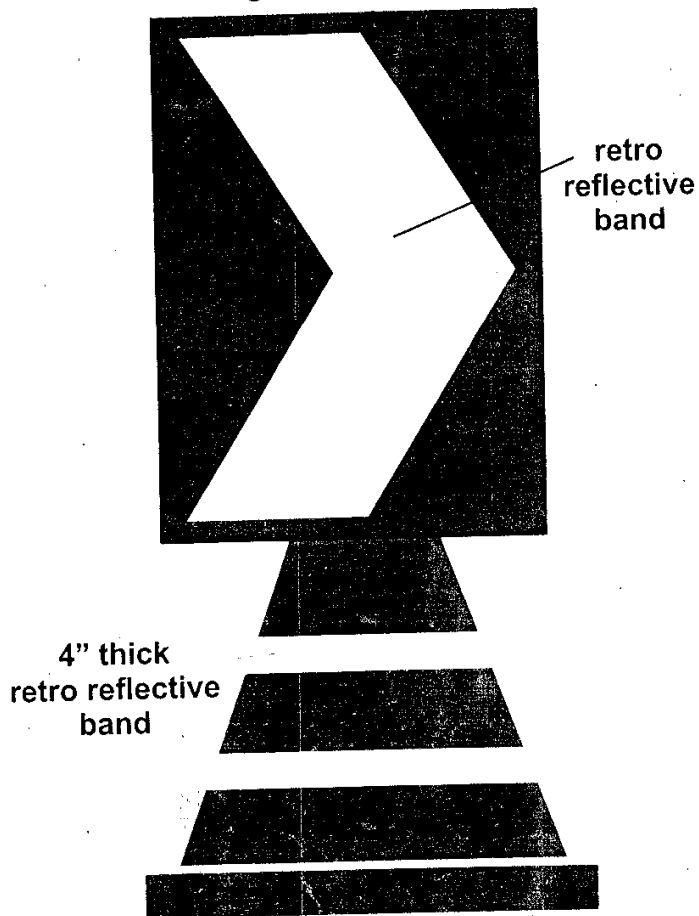

PLASTIC CONE WITH
ARROW HAZARD MARKER
CONE SIZE 73 CM HEIGHT, SQUARE BASE
OF 39 CM & TOP DIA. OF 6 CM. WITH
ARRANGEMENT OF FILLING SAND NOT
LESS THAN 20 KG.
SIGN PLATE SIZE 45 X 60 CM

Signature of Contractor

No. of Corrections

City Engineer
TMC, Thane

सुरक्षा साधन - ८

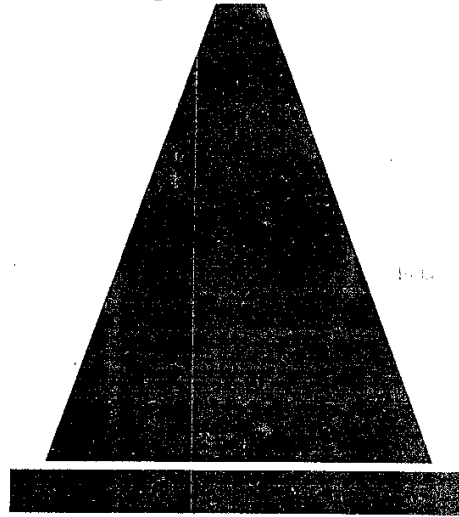

**PLASTIC CONE
CONE SIZE 70 CM HEIGHT, BASE 5 CM**

Signature of Contractor

No. of Corrections

City Engineer
TMC, Thane

माहितीफलक - ९

 ठाणे महानगरपालिका, ठाणे
सार्वजनिक बांधकाम विभाग

-रस्त्याचे काम सुरु आहे. रस्ता वाहतूकीस बंद करण्यात आला आहे.
- कृपया नागरिकांनी पर्यायी मार्गाचा वापर करावा व महानगरपालिकेस सहकार्य करावे.
- असुविधेबाबत दिलगीर आहोत.



BOARD SIZE 1 M X 1 M

Signature of Contractor

No. of Corrections

City Engineer
TMC, Thane

ROAD LANDSCAPING CONCEPT, THANE CITY



Signature of Contractor

No. of Corrections

City Engineer
TMC, Thane