

**GREATER VISAKHAPATNAM SMART CITY
CORPORATION LIMITED**

**REQUEST FOR PROPOSAL
FOR**

**Design, Manufacture, Supply, Installation and
Commissioning of Different Capacity Roof Top
Solar Photo Voltaic Power Projects on
Government Buildings (22 Locations) under
Net Metering Policy in Visakhapatnam City
under implementation of Smart City Mission**

(5TH MAY 2017)

**GREATER VISAKHAPATNAM SMART CITY CORPORATION
LIMITED, VISAKHAPATNAM (GVSCCL)**

Ref: GVSCCL/Projects/07(SRT-1)/2017-18/36 /Dt: 01-05-2017

REQUEST FOR PROPOSAL (RFP)

GVSCCL invites Request for Proposal (RFP) for selection of “Design, Manufacture, Supply, Installation and Commissioning of Different Capacity Roof Top Solar Photo Voltaic Power Projects on Government Buildings (22 Locations) under Net Metering Policy in Visakhapatnam City under implementation of Smart City Mission”. The detailed RFP including EMD, TOR, Eligibility criteria etc., can be downloaded from website of www.apecurement.gov.in and available at www.gvmc.gov.in from 5TH May 2017 onwards. ***The last date for online submission of bids is 25TH May 2017 up to 5.00 PM.***

For more details contact:

Greater Visakhapatnam Smart City Corporation Ltd.

E-mail: Prabhu.Sheelavantha@aecom.com

Cc: visakhapatnamsmartcity@gmail.com

Tel No./Fax 0891-2746300

Mobile No. 9906277734

**Sd/-
Managing Director & CEO,
GVSCCL**

PART 1 – Bidding Procedures

Table of Contents

| | |
|---|-----------|
| A. Introduction..... | 7 |
| 1. Eligible Bidders | 7 |
| 3. Eligible Plant, Equipment, and Services..... | 7 |
| 4. Cost of Bidding..... | 8 |
| B. The Bidding Documents | 9 |
| 5. Content of Bidding Documents | 9 |
| 6. Clarification of Bidding Documents; and Pre-Bid Meeting | 9 |
| 7. Amendment of Bidding Documents | 10 |
| C. Preparation of Bids | 11 |
| 8. Language of Bid..... | 11 |
| 9. Documents Comprising the Bid..... | 11 |
| 10. Bid Form and Price Schedules..... | 16 |
| 11. Bid Prices | 16 |
| 12. Bid Currencies | 18 |
| 13. Bid Security..... | 19 |
| 14. Period of Validity of Bid..... | 20 |
| 15. Format and Signing of Bid..... | 20 |
| D. Submission of Bids | 21 |
| 16. Sealing and Marking of Bids | 21 |
| 17. Deadline for Submission of Bids | 22 |
| 18. Late Bids | 22 |
| 19. Modification and Withdrawal of Bids | 22 |
| E. Bid Opening and Evaluation..... | 23 |
| 20. Opening of Bids by Employer..... | 23 |
| 21. Clarification of Bids..... | 23 |
| 22. Preliminary Examination of Bids..... | 24 |
| 23. Conversion to Single Currency..... | 25 |
| 24. Technical Evaluation | 25 |
| 25. Commercial Evaluation | 26 |
| 26. Domestic Preference | 29 |
| 27. Contacting the Employer | 29 |
| F. Award of Contract..... | 29 |
| 28. Post-qualification | 29 |
| 29. Award Criteria | 30 |
| 30. Employer's Right to Accept Any Bid and to Reject Any or All Bids..... | 30 |
| 31. Notification of Award..... | 30 |
| 32. Signing the Contract Agreement..... | 30 |
| 33. Performance Security | 31 |

| | | |
|-----|---------------------------------------|----|
| 34. | Adjudicator | 31 |
| 35. | Corrupt or Fraudulent Practices | 31 |

Key Dates

| S. No. | Activity | Deadline |
|---------------|---|--|
| 1 | Release of RFP | 05/05/ 2017 |
| 2 | Last date of receipt of queries on RFP by electronic submission | 15/05/2017, 1600 Hrs |
| 3 | Posting of response to queries | 20/05/2017 |
| 4 | Last date for submission of Bids Online Hardcopy | 25/05/2017; 1700 Hrs 26/05/2017, 1700 Hrs |
| 5 | Date of opening of technical bids | 25/05/2017, 1800 Hrs |
| 6 | Date of opening of Financial Bid | To be intimated later |
| 7 | EMD for the Project | INR 8.00 Lacs on the name of “ Managing Director, GVSCCL” |
| 8 | Documentation fee | INR 5,000/- Demand Draft on the name of “ Managing Director, GVSCCL” |
| 9 | Tenders can be downloaded from | www.apecurement.gov.in & www.gvmc.gov.in |
| 10 | Bids shall be submitted/uploaded only on | www.apecurement.gov.in |
| 11 | Qualification Criteria | ITB 9.3(c) &(e), pg no 33 |

Instructions to Bidders

A. Introduction

| | |
|---|--|
| 1. Eligible Bidders | <p>1.1 This Invitation for Bids, issued by the Employer named in the Bid Data Sheet, is open to all suppliers from eligible bidders, except as provided hereinafter.</p> <p>1.2 Bidders should not be associated, or have been associated in the past, directly or indirectly, with a firm or any of its affiliates that has been engaged by the Employer to provide consulting services for the preparation of the design, specifications, and other documents to be used for the procurement of the facilities to be purchased under this Invitation for Bids.</p> <p>1.3 Government-owned enterprises in the country may only participate on their own or as members of a joint venture or a consortium if they are legally and financially autonomous, operate under commercial law.</p> <p>1.4 Bidders shall not be under a declaration of ineligibility for corrupt and fraudulent practices issued by the Employer in accordance with ITB Sub-Clause 35.1.</p> |
| 3. Eligible Plant, Equipment, and Services | <p>3.1 For the purposes of these bidding documents, the words “facilities,” “plant and equipment,” “installation services,” etc., shall be construed in accordance with the respective definitions given to them in the General Conditions of Contract.</p> <p>3.2 All plant and equipment to be supplied and installed and services carried out under the contract shall have their origin in eligible source countries, <i>State/National Guidelines for Procurement</i>, and all expenditures made under the contract will be limited to such plant, equipment, and services.</p> <p>3.3 For purposes of this clause, “origin” means the place where the plant and equipment or component parts thereof are mined, grown, or produced. Plant and equipment are produced when, through manufacturing, processing or substantial and major assembling of components, a commercially recognized product results that is substantially different in basic characteristics or in purpose or utility from its components.</p> |

| | |
|---------------------------|--|
| | 3.4 The origin of the plant, equipment, and services is distinct from the nationality of the Bidder. |
| 4. Cost of Bidding | 4.1 The Bidder shall bear all costs associated with the preparation and submission of its bid, and the Employer will in no case be responsible or liable for these costs, regardless of the conduct or outcome of the bidding process. |

B. The Bidding Documents

| | |
|--|---|
| <p>5. Content of Bidding Documents</p> | <p>5.1 The facilities required, bidding procedures, contract terms and technical requirements are prescribed in the bidding documents. The bidding documents include the following sections:</p> <p style="padding-left: 40px;"> Invitation for Bids (IFB) Instructions to Bidders (ITB) Bid Data Sheet (BDS) General Conditions of Contract (GCC) Special Conditions of Contract (SCC) Technical Specifications and Drawings (TS) Forms and Procedures (FP) <ol style="list-style-type: none"> 1. Bid Form and Price Schedules 2. Bid Security Form 3. Form of Contract Agreement 4. Performance Security Forms 5. Bank Guarantee Form for Advance Payment 6. Form of Completion Certificate 7. Form of Operational Acceptance Certificate 8. Change Order Procedures </p> <p>5.2 The Bidder is expected to examine all instructions, forms, terms, specifications and other information in the bidding documents. Failure to furnish all information required by the bidding documents or submission of a bid not substantially responsive to the bidding documents in every respect will be at the Bidder's risk and may result in rejection of its bid.</p> |
| <p>6. Clarification of Bidding Documents; and Pre-Bid Meeting</p> | <p>6.1 A prospective Bidder requiring any clarification of the bidding documents may notify the Employer in writing or by cable (hereinafter, the term cable is deemed to include Electronic Data Interchange (EDI), telex or telefax) at the Employer's mailing address indicated in the Bid Data Sheet. Similarly, if a Bidder feels that any important provision in the documents, such as those listed in ITB Sub-Clause 22.5, will be unacceptable, such an issue should be raised at this stage. The Employer will respond in writing to any request for clarification or modification of the bidding documents that it receives no later than twenty-eight (28) days prior to the deadline for submission of bids prescribed by the Employer. Written copies of the Employer's response (including an explanation of the query but not identification of its source) will be sent to all prospective bidders that have received the bidding documents.</p> |

| | |
|---|---|
| | <p>6.2 The Bidder is advised to visit and examine the site where the facilities are to be installed and its surroundings and obtain for itself on its own responsibility all information that may be necessary for preparing the bid and entering into a contract for supply and installation of the facilities. The costs of visiting the site shall be at the Bidder's own expense.</p> <p>6.3 The Bidder and any of its personnel or agents will be granted permission by the Employer to enter upon its premises and lands for the purpose of such inspection, but only upon the express condition that the Bidder, its personnel and agents will release and indemnify the Employer and its personnel and agents from and against all liability in respect thereof and will be responsible for death or personal injury, loss of or damage to property and any other loss, damage, costs and expenses incurred as a result of the inspection.</p> <p>6.4 The Bidder's designated representative is invited to attend a pre-bid meeting, which, if convened, will take place at the venue and time stipulated in the Bid Data Sheet. The purpose of the meeting will be to clarify issues and to answer questions on any matter that may be raised at that stage. The Bidder is requested, as far as possible, to submit any question in writing or by cable, to reach the Employer not later than one week before the meeting. It may not be practicable at the meeting to answer questions received late, but questions and responses will be transmitted as indicated hereafter. Minutes of the meeting, including the text of the questions raised and the responses given, together with any responses prepared after the meeting will be transmitted without delay to all purchasers of the bidding documents. Any modification of the bidding documents listed in ITB Sub-Clause 5.1 which may become necessary as a result of the pre-bid meeting shall be made by the Employer exclusively through the issue of an Addendum pursuant to ITB Clause 7 and not through the minutes of the pre-bid meeting.</p> |
| <p>7. Amendment of Bidding Documents</p> | <p>7.1 At any time prior to the deadline for submission of bids, the Employer may, for any reason, whether at its own initiative, or in response to a clarification requested by a prospective Bidder, amend the bidding documents.</p> <p>7.2 The amendment will be notified in writing or by cable to all prospective bidders that have purchased the bidding documents and will be binding on them. Bidders are required to</p> |

| | |
|--|---|
| | <p>immediately acknowledge receipt of any such amendment, and it will be assumed that the information contained therein will have been taken into account by the Bidder in its bid.</p> <p>7.3 In order to afford prospective Bidders reasonable time in which to take the amendment into account in preparing their bid, the Employer may, at its discretion, extend the deadline for the submission of bids, in which case, the Employer will notify all bidders in writing of the extended deadline.</p> |
|--|---|

C. Preparation of Bids

| | |
|---|--|
| <p>8. Language of Bid</p> | <p>8.1 The bid prepared by the Bidder and all correspondence and documents related to the bid exchanged by the Bidder and the Employer shall be written in the language specified in the Bid Data Sheet, provided that any printed literature furnished by the Bidder may be written in another language, as long as such literature is accompanied by a translation of its pertinent passages in the language specified in the Bid Data Sheet, in which case, for purposes of interpretation of the bid, the translation shall govern.</p> |
| <p>9. Documents Comprising the Bid</p> | <p>9.1 The bid submitted by the Bidder shall comprise the following documents:</p> <ul style="list-style-type: none"> (a) Bid Form duly completed and signed by the Bidder, together with all Attachments identified in ITB Sub-Clause 9.3 below. (b) Price Schedules duly completed by the Bidder. <p>9.2 Bidders shall note that, if permitted according to the Bid Data Sheet, they are entitled to submit an alternative bid within the scope specified in the Bid Data Sheet. In such cases, bidders shall submit full details and justifications, etc., in Attachment 7 to the bid as indicated in ITB Sub-Clause 9.3 (g) below.</p> <p>9.3 Each Bidder shall submit with its bid the following attachments:</p> <ul style="list-style-type: none"> (a) <u>Attachment 1: Bid Security</u> A bid security furnished in accordance with ITB Clause 13. (b) <u>Attachment 2: Power of Attorney</u> A power of attorney, duly notarized, indicating that the |

| | |
|--|--|
| | <p>person(s) signing the bid has(ve) the authority to sign the bid and thus that the bid is binding upon the Bidder during the full period of its validity in accordance with ITB Clause 14.</p> <p>(c) <u>Attachment 3: Bidder's Eligibility and Qualifications</u> In the absence of prequalification, documentary evidence established in accordance with ITB Clause 2 that the Bidder is eligible to bid and is qualified to perform the contract if its bid is accepted.</p> <p>The documentary evidence of the Bidder's eligibility to bid shall establish to the Employer's satisfaction that the Bidder, at the time of submission of its bid, is from an eligible source country as defined in ITB Sub-Clause 2.1.</p> <p>The documentary evidence of the Bidder's qualifications to perform the contract, if its bid is accepted, shall establish to the Employer's satisfaction that the Bidder has the financial, technical, production, procurement, shipping, installation and other capabilities necessary to perform the contract, and, in particular, meets the experience and other criteria outlined in the Bid Data Sheet.</p> <p>Bids submitted by a joint venture or a consortium of two or more firms as partners shall comply with the following requirements:</p> <ul style="list-style-type: none">(i) The bid shall include all the information required for Attachment 3 as described above for each joint venture or consortium partner.(ii) The bid shall be signed so as to be legally binding on all partners.(iii) One of the partners responsible for performing a key component of the contract shall be designated as leader, this authorization shall be evidenced by submitting with the bid a power of attorney signed by legally authorized signatures.(iv) The leader shall be authorized to incur liabilities and receive instructions for and on behalf of any and all partners of the joint venture or consortium, and the entire execution of the contract, including payment, |
|--|--|

| | |
|--|--|
| | <p>shall be done exclusively with the leader.</p> <p>(v) All partners of the joint venture or consortium shall be liable jointly and severally for the execution of the contract in accordance with the contract terms.</p> <p>(vi) A copy of the agreement entered into by the joint venture or consortium partners shall be submitted with the bid.</p> <p>In order for a joint venture or consortium to qualify, each of its partners or combination of partners must meet the minimum criteria listed for an individual Bidder for the component of the contract they are designated to perform. Failure to comply with this requirement will result in rejection of the joint venture or consortium's bid.</p> <p>A firm can be a partner in only one joint venture or consortium; bids submitted by joint ventures or consortia including the same firm as partner will be rejected.</p> <p>In the case of a Bidder who offers to supply and/or install plant and equipment under the contract that the Bidder did not manufacture or otherwise produce and/or install, the Bidder shall (i) have the financial and other capabilities necessary to perform the contract; (ii) have been duly authorized by the manufacturer or producer of the related plant and equipment or component to supply and/or install that item in the Employer's country; and (iii) be responsible for ensuring that the manufacturer or producer complies with the requirements of ITB Sub-Clause 2.1 and meets the minimum criteria listed for an individual Bidder for that item.</p> <p>(d) <u>Attachment 4: Eligibility and Conformity of the Facilities</u> Documentary evidence established in accordance with ITB Clause 3 that the facilities offered by the Bidder in its bid or in any alternative bid (if permitted) are eligible and conform to the bidding documents.</p> <p>The documentary evidence of the eligibility of the facilities shall consist of a statement on the country of origin of the plant and equipment offered, which shall be confirmed by a certificate of origin issued at the time of shipment.</p> |
|--|--|

| | |
|--|---|
| | <p>The documentary evidence of the conformity of the facilities to the bidding documents may be in the form of literature, drawings and data, and shall furnish:</p> <ul style="list-style-type: none">(i) a detailed description of the essential technical and performance characteristics of the facilities;(ii) a list giving full particulars, including available sources, of all spare parts, special tools, etc., necessary for the proper and continuing functioning of the facilities for the period named in the Bid Data Sheet, following completion of facilities in accordance with provisions of contract; and(iii) a commentary on the Employer's Technical Specifications and adequate evidence demonstrating the substantial responsiveness of the facilities to those specifications. Bidders shall note that standards for workmanship, materials and equipment designated by the Employer in the bidding documents are intended to be descriptive (establishing standards of quality and performance) only and not restrictive. The Bidder may substitute alternative standards, brand names and/or catalog numbers in its bid, provided that it demonstrates to the Employer's satisfaction that the substitutions are substantially equivalent or superior to the standards designated in the Technical Specifications. <p>(e) <u>Attachment 5: Subcontractors Proposed by the Bidder</u> The Bidder shall include in its bid details of all major items of supply or services that it proposes to purchase or sublet, and shall give details of the name and nationality of the proposed Subcontractor, including vendors, for each of those items. Bidders are free to list more than one Subcontractor against each item of the facilities. Quoted rates and prices will be deemed to apply to whichever Subcontractor is appointed, and no adjustment of the rates and prices will be permitted.</p> <p>The Bidder shall be responsible for ensuring that any Subcontractor proposed complies with the requirements of ITB Sub-Clause 2.1, and that any plant, equipment or services to be provided by the Subcontractor comply with the requirements of ITB Clause 3 and ITB Sub-Clause 9.3</p> |
|--|---|

| | |
|--|---|
| | <p>(c). The Employer reserves the right to delete any proposed Subcontractor from the list prior to award of contract, and after discussion between the Employer and the Contractor, the corresponding Appendix to the form of Contract Agreement shall be completed, listing the approved Subcontractors for each item concerned.</p> <p>(f) <u>Attachment 6: Deviations</u> In order to facilitate evaluation of bids, deviations, if any, from the terms and conditions or Technical Specifications shall be listed in Attachment 6 to the bid. The Bidder shall also provide the additional price, for withdrawal of the deviations. However, the attention of the bidders is drawn to the provisions of ITB Sub-Clause 22.4 regarding the rejection of bids that are not substantially responsive to the requirements of the bidding documents.</p> <p>(g) <u>Attachment 7: Alternative Bids</u></p> <p>(i) When alternatives to the Time Schedule called for in the corresponding Appendix to the Contract Agreement are explicitly invited, a statement to that effect will be included in the Bid Data Sheet, as will the method of evaluating different time schedules.</p> <p>(ii) Except as provided under subparagraph (iii) below, bidders wishing to offer technical alternatives to the requirements of the bidding documents must first price the Employer's design of the facilities as described in the bidding documents, and shall further provide all information necessary for a complete evaluation of the alternatives by the Employer, including drawings, design calculations, technical specifications, breakdown of prices, proposed installation methodology and other relevant details. Only the technical alternatives, if any, of the lowest evaluated Bidder conforming to the basic technical requirements shall be considered by the Employer.</p> <p>(iii) When bidders are permitted in the Bid Data Sheet to submit alternative technical solutions for specified parts of the facilities, such parts shall be described in Section VI, Technical Specifications and Drawings. Technical alternatives that comply with the performance and technical criteria specified for the facilities shall be considered by the Employer on their</p> |
|--|---|

| | |
|---|--|
| | own merits, pursuant to ITB Sub-Clause 24.2. |
| 10. Bid Form and Price Schedules | 10.1 The Bidder shall complete the Bid Form and the appropriate Price Schedules furnished in the bidding documents as indicated therein and in the Subsection "Bid Form and Price Schedules" of the bidding documents, following the requirements of ITB Clauses 11 and 12. |
| 11. Bid Prices | <p>11.1 Unless otherwise specified in the Technical Specifications, bidders shall quote for the entire facilities on a "single responsibility" basis such that the total bid price covers all the Contractor's obligations mentioned in or to be reasonably inferred from the bidding documents in respect of the design, manufacture, including procurement and subcontracting (if any), delivery, construction, installation and completion of the facilities. This includes all requirements under the Contractor's responsibilities for testing, precommissioning and commissioning of the facilities and, where so required by the bidding documents, the acquisition of all permits, approvals and licenses, etc.; the operation, maintenance and training services and such other items and services as may be specified in the bidding documents, all in accordance with the requirements of the General Conditions of Contract. Items against which no price is entered by the Bidder will not be paid for by the Employer when executed and shall be deemed to be covered by the prices for other items.</p> <p>11.2 Bidders are required to quote the price for the commercial, contractual and technical obligations outlined in the bidding documents. If a Bidder wishes to make a deviation, such deviation shall be listed in Attachment 6 of its bid. The Bidder shall also provide the additional price, if any, for withdrawal of the deviations.</p> <p>11.3 Bidders shall give a breakdown of the prices in the manner and detail called for in the Price Schedules. Where no Price Schedules are included in the bidding documents, bidders shall present their prices in the following manner:</p> <p>Separate numbered Schedules shall be used for each of the following elements. The total amount from each Schedule (1 to 4) shall be summarized in a Grand Summary (Schedule 5) giving the total bid price(s) to be entered in the Bid Form.</p> <p>Schedule No. 1 Plant and Equipment (including Mandatory Spare Parts) Supplied from Abroad</p> <p>Schedule No. 2 Plant and Equipment (including Mandatory Spare Parts) Supplied from within the</p> |

| | |
|--|--|
| | <p style="text-align: center;">Employer's Country</p> <p>Schedule No. 3 Local Transportation Schedule No. 4 Installation Services Schedule No. 5 Grand Summary (Schedule Nos. 1 to 4) Schedule No. 6 Recommended Spare Parts</p> <p>Bidders shall note that the plant and equipment included in Schedule Nos. 1 and 2 above exclude materials used for civil, building and other construction works. All such materials shall be included and priced under Schedule No. 4, Installation Services.</p> <p>11.4 In the Schedules, bidders shall give the required details and a breakdown of their prices as follows:</p> <ul style="list-style-type: none"> (a) Plant and equipment to be supplied from abroad (Schedule No. 1) shall be quoted on a CIF port-of-entry, CIP border point basis or CIP-named place. In addition, the FOB price (or the FCA price, as the case may be) shall also be indicated. (b) Plant and equipment manufactured or fabricated within the Employer's country (Schedule No. 2) shall be quoted on an EXW (ex factory, ex works, ex warehouse or off-the-shelf, as applicable) basis, and shall be inclusive of all costs as well as duties and taxes paid or payable on components and raw materials incorporated or to be incorporated in the facilities. (c) Local transportation, insurance and other services incidental to delivery of the plant and equipment. (Schedule No. 3). (d) Installation Services shall be quoted separately (Schedule No. 4) and shall include rates or prices for all labor, contractor's equipment, temporary works, materials, consumables and all matters and things of whatsoever nature, including operations and maintenance services, the provision of operations and maintenance manuals, training, etc., where identified in the bidding documents, as necessary for the proper execution of the Installation Services, including all taxes, duties, levies and charges payable in the Employer's country as of twenty-eight (28) days prior to the deadline for submission of bids. (e) Recommended spare parts shall be quoted separately (Schedule 6) as specified in either subparagraph (a) or (b) |
|--|--|

| | |
|----------------------------------|---|
| | <p>above in accordance with the origin of the spare parts.</p> <p>11.5 The terms EXW, CIF, CIP, etc., shall be governed by the rules prescribed in the current edition of <i>Incoterms</i>, published by the International Chamber of Commerce, 38 Cours Albert 1^{er}, 75008 Paris, France.</p> <p>11.6 The prices shall be in accordance with one of the following alternatives, as specified in the Bid Data Sheet:</p> <p>(a) Fixed Price. Prices quoted by the Bidder shall be fixed during the Bidder's performance of the contract and not subject to variation on any account. A bid submitted with an adjustable price quotation will be treated as nonresponsive and rejected.</p> <p>or</p> <p>(b) Adjustable Price. Prices quoted by the Bidder shall be subject to adjustment during performance of the contract to reflect changes in the cost elements such as labor, material, transport and contractor's equipment in accordance with the procedures specified in the corresponding Appendix to the Form of Contract Agreement. A bid submitted with a fixed price quotation will not be rejected, but the price adjustment will be treated as zero. The price adjustment provision will not be taken into consideration in bid evaluation. Bidders are required to indicate the source of labor and material indexes in the said corresponding Appendix.</p> |
| <p>12. Bid Currencies</p> | <p>12.1 Prices shall be quoted in the following currencies:</p> <p>(a) Plant and equipment covered under ITB Sub-Clause 11.4 (a) to be supplied from abroad shall be quoted entirely in the currency of any local country. If the Bidder wishes to be paid in a combination of amounts in different currencies, it may quote its price accordingly, but use no more than three foreign currencies.</p> <p>(b) Plant and equipment covered under ITB Sub-Clause 11.4 (b) to be supplied from within the Employer's country shall be quoted in the currency of the Employer's country, unless otherwise specified in the Bid Data Sheet.</p> |

| | |
|--------------------------------|---|
| | <p>(c) Unless otherwise specified in the Bid Data Sheet, local transportation, insurance and other services incidental to delivery of the plant and equipment covered under ITB Sub-Clause 11.4 (c) and installation services covered under ITB Sub-Clause 11.4 (d) shall be quoted in either foreign and/or local currency, depending upon the currency in which the costs are to be incurred and in accordance with the provisions of ITB Sub-Clause 11.4 (a) and (b) above.</p> |
| <p>13. Bid Security</p> | <p>13.1 The Bidder shall furnish, as part of its bid, a bid security in the amount stipulated in the Bid Data Sheet in the currency of the Employer's country, or in the equivalent amount in a freely convertible currency.</p> <p>13.2 The bid security shall, at the Bidder's option, be in the form of a certified check, letter of credit or a bank guarantee from a reputable bank selected by the Bidder and located in any eligible country. The format of the bank guarantee shall be in accordance with the form of bid security included in the bidding documents; other formats may be permitted, subject to the prior approval of the Employer. Bid security shall remain valid for a period of twenty-eight (28) days beyond the original bid validity period, and beyond any extension subsequently requested under ITB Sub-Clause 14.2.</p> <p>13.3 Any bid not accompanied by an acceptable bid security shall be rejected by the Employer as being nonresponsive, pursuant to ITB Clause 22.5. The bid security of a joint venture must be in the name of all the partners in the joint venture submitting the bid.</p> <p>13.4 The bid securities of unsuccessful bidders will be returned as promptly as possible, but not later than twenty-eight (28) days after the expiration of the bid validity period.</p> <p>13.5 The bid security of the successful Bidder will be returned when the Bidder has signed the Contract Agreement, pursuant to ITB Clause 32, and has furnished the required performance security, pursuant to ITB Clause 33.</p> <p>13.6 The bid security may be forfeited</p> <p>(a) if the Bidder withdraws its bid during the period of bid validity specified by the Bidder in the Bid Form</p> |

| | |
|---|---|
| | <p>(b) in the case of a successful Bidder, if the Bidder fails within the specified time limit</p> <p>(i) to sign the Contract Agreement, in accordance with ITB Clause 32, or</p> <p>(ii) to furnish the required performance security, in accordance with ITB Clause 33.</p> |
| <p>14. Period of Validity of Bid</p> | <p>14.1 Bids shall remain valid for the period named in the Bid Data Sheet after the closing date prescribed by the Employer for the receipt of bids, pursuant to ITB Sub-Clause 17.1. A bid valid for a shorter period shall be rejected by the Employer as being nonresponsive.</p> <p>14.2 In exceptional circumstance, the Employer may solicit the Bidder's consent to an extension of the bid validity period. The request and responses thereto shall be made in writing or by cable. If a Bidder accepts to prolong the period of validity, the bid security shall also be suitably extended. A Bidder may refuse the request without forfeiting its bid security. A Bidder granting the request will not be required or permitted to modify its bid, except as provided in ITB Sub-Clause 14.3.</p> <p>14.3 In the case of fixed price contracts (not subject to price adjustment), if the bid validity period is extended beyond sixty (60) days, the amounts payable in both local and foreign currencies to the Bidder selected for award shall be increased by applying the factors specified in the request for extension to both the local and the foreign currency component of the payments, respectively, for the period of delay beyond sixty (60) days after the expiry of the initial bid validity up to the time of notification of award. Bid evaluation will be based on the bid prices without considering the above correction.</p> |
| <p>15. Format and Signing of Bid</p> | <p>15.1 The Bidder shall prepare an original and the number of copies/sets of the bid specified in the Bid Data Sheet, clearly marking each one as "ORIGINAL BID," "COPY NO. 1," "COPY NO. 2," etc., as appropriate. In the event of any discrepancy between them, the original shall govern.</p> <p>15.2 The original and all copies of the bid, each consisting of the documents listed in ITB Sub-Clause 9.1, shall be typed or written in indelible ink and shall be signed by the Bidder or a person or persons duly authorized to bind the Bidder to the contract. The</p> |

| | |
|--|--|
| | <p>latter authorization shall be indicated by written power of attorney accompanying the bid and submitted as Attachment 2 to the Bid under ITB Sub-Clause 9.3. All pages of the bid, except for unamended printed literature, shall be initialed by the person or persons signing the bid.</p> <p>15.3 The bid shall contain no alterations, omissions or additions, unless such corrections are initialed by the person or persons signing the bid.</p> <p>15.4 The Bidder shall furnish information as described in the last paragraph of the Form of Bid on commissions or gratuities, if any, paid or to be paid to agents relating to this bid, and to contract execution if the Bidder is awarded the contract.</p> |
|--|--|

D. Submission of Bids

| | |
|---|--|
| <p>16. Sealing and Marking of Bids</p> | <p>16.1 The Bidder shall submit the Bid as mentioned in the ITB. The Original required shall be sealed and marked original and each copy of the bid in separate envelopes, duly marking the envelopes as “ORIGINAL BID” and “COPY NO. [number]” The envelopes shall then be sealed in an outer envelope.</p> <p>16.2 The inner and outer envelopes shall</p> <ul style="list-style-type: none"> (a) be addressed to the Employer at the address given in the Bid Data Sheet, and (b) bear the contract name indicated in the Bid Data Sheet, the Invitation for Bids title and number indicated in the Bid Data Sheet, and the statement “DO NOT OPEN BEFORE [date],” to be completed with the time and date specified in the Bid Data Sheet, pursuant to ITB Sub-Clause 20.1. <p>16.3 The inner envelopes shall also indicate the name and address of the Bidder so that the bid can be returned unopened in case it is declared “late.”</p> <p>16.4 If the outer envelope is not sealed and marked as required by ITB Sub-Clause 16.2 above, the Employer will assume no responsibility for the bid’s misplacement or premature opening. If the outer envelope discloses the Bidder’s identity, the Employer will not guarantee the anonymity of the bid submission, but this disclosure will not constitute grounds for bid</p> |
|---|--|

| | |
|--|---|
| | rejection. |
| 17. Deadline for Submission of Bids | <p>17.1 Bids must be received by the Employer at the address specified under ITB Sub-Clause 16.2 no later than the time and date stated in the Bid Data Sheet.</p> <p>17.2 The Employer may, at its discretion, extend this deadline for submission of bids by amending the bidding documents in accordance with ITB Sub-Clause 7.3, in which case all rights and obligations of Employer and bidders will thereafter be subject to the deadline as extended.</p> |
| 18. Late Bids | <p>18.1 Any bid received by the Employer after the bid submission deadline prescribed by the Employer, pursuant to ITB Clause 17, will be rejected and returned unopened to the Bidder.</p> |
| 19. Modification and Withdrawal of Bids | <p>19.1 The Bidder may modify or withdraw its bid after submission, provided that written notice of the modification or withdrawal is received by the Employer prior to the deadline prescribed for bid submission.</p> <p>19.2 The Bidder's modifications shall be prepared, sealed, marked and dispatched as follows:</p> <ul style="list-style-type: none"> (a) The Bidders shall provide an original and the number of copies specified in the Bid Data Sheet of any modifications to its bid, clearly identified as such, in two inner envelopes duly marked "BID MODIFICATIONS—ORIGINAL" and "BID MODIFICATIONS—COPIES." The inner envelopes shall be sealed in an outer envelope, which shall be duly marked "BID MODIFICATIONS." (b) Other provisions concerning the marking and dispatch of bid modifications shall be in accordance with ITB Sub-Clauses 16.2, 16.3 and 16.4. <p>19.3 A Bidder wishing to withdraw its bid shall notify the Employer in writing prior to the deadline prescribed for bid submission. The notice of withdrawal shall</p> <ul style="list-style-type: none"> (a) be addressed to the Employer at the address named in the Bid Data Sheet, and (b) bear the contract name, the IFB number, and the words "BID WITHDRAWAL NOTICE." Bid withdrawal notices |

| | |
|--|---|
| | <p>received after the bid submission deadline will be ignored, and the submitted bid will be deemed to be a validly submitted bid.</p> <p>19.4 No bid may be withdrawn in the interval between the bid submission deadline and the expiration of the bid validity period specified in ITB Clause 14. Withdrawal of a bid during this interval may result in the Bidder's forfeiture of its bid security, pursuant to ITB Sub-Clause 13.6.</p> |
|--|---|

E. Bid Opening and Evaluation

| | |
|---|--|
| <p>20. Opening of Bids by Employer</p> | <p>20.1 The Employer will open the bids, including withdrawals and modifications made pursuant to ITB Clause 19, in the presence of bidders' designated representatives who choose to attend, at the time, date, and location stipulated in the Bid Data Sheet. The bidders' representatives who are present shall sign a register evidencing their attendance.</p> <p>20.2 Envelopes marked "WITHDRAWAL" shall be opened first and the name of the Bidder shall be read out. Bids for which an acceptable notice of withdrawal has been submitted pursuant to ITB Clause 19 shall not be opened.</p> <p>20.3 The bidders' names, the Bid Prices, including any alternative Bid Price or deviation, any discounts, bid modifications and withdrawals, the presence (or absence) of bid security, and any such other details as the Employer may consider appropriate, will be announced by the Employer at the opening. Subsequently, all envelopes marked "MODIFICATION" shall be opened and the submissions therein read out in appropriate detail. No bid shall be rejected at bid opening except for late bids pursuant to ITB Clause 18.</p> <p>20.4 The Employer shall prepare minutes of the bid opening, including the information disclosed to those present in accordance with ITB Sub-Clause 20.3.</p> <p>20.5 Bids not opened and read out at bid opening shall not be considered further for evaluation, irrespective of the circumstances.</p> |
| <p>21. Clarification of Bids</p> | <p>21.1 During bid evaluation, the Employer may, at its discretion, ask the Bidder for a clarification of its bid. The request for clarification and</p> |

| | |
|---|--|
| | <p>the response shall be in writing, and no change in the price or substance of the bid shall be sought, offered or permitted.</p> |
| <p>22. Preliminary Examination of Bids</p> | <p>22.1 The Employer will examine the bids to determine whether they are complete, whether any computational errors have been made, whether required sureties have been furnished, whether the documents have been properly signed, and whether the bids are generally in order.</p> <p>22.2 Arithmetical errors will be rectified on the following basis. If there is a discrepancy between the unit price and the total price, which is obtained by multiplying the unit price and quantity, or between subtotals and the total price, the unit or subtotal price shall prevail, and the total price shall be corrected. If there is a discrepancy between words and figures, the amount in words will prevail. If the Bidder does not accept the correction of errors, its bid will be rejected.</p> <p>22.3 The Employer may waive any minor informality, nonconformity or irregularity in a bid that does not constitute a material deviation, whether or not identified by the Bidder in Attachment 6 to its bid, and that does not prejudice or affect the relative ranking of any Bidder as a result of the technical and commercial evaluation, pursuant to ITB Clauses 24 and 25.</p> <p>22.4 Prior to the detailed evaluation, the Employer will determine whether each bid is of acceptable quality, is complete and is substantially responsive to the bidding documents. For purposes of this determination, a substantially responsive bid is one that conforms to all the terms, conditions and specifications of the bidding documents without material deviations, objections, conditionalities or reservations. A material deviation, objection, conditionality or reservation is one (i) that affects in any substantial way the scope, quality or performance of the contract; (ii) that limits in any substantial way, inconsistent with the bidding documents, the Employer's rights or the successful Bidder's obligations under the contract; or (iii) whose rectification would unfairly affect the competitive position of other bidders who are presenting substantially responsive bids.</p> <p>22.5 If a bid is not substantially responsive, it will be rejected by the Employer, and may not subsequently be made responsive by the Bidder by correction of the nonconformity. The Employer's determination of a bid's responsiveness is to be based on the contents of the bid itself without recourse to extrinsic evidence.</p> |

| | |
|---|--|
| <p>23. Conversion to Single Currency</p> | <p>23.1 To facilitate evaluation and comparison, the Employer will convert all bid prices expressed in the amounts in various currencies in which the bid price is payable to either</p> <ul style="list-style-type: none"> (a) the currency of the Employer's country at the selling exchange rate established for similar transactions by the central bank or by a commercial bank in the Employer's country, or (b) a currency widely used in international trade, such as U.S. dollars, at the selling rate of exchange published in the international press for the amount payable in foreign currency, and at the selling exchange rate established for similar transactions by the central bank in the Employer's country for the amount payable in the currency of the Employer's country. <p>23.2 The currency selected for converting bid prices to a common base for the purpose of evaluation, along with the source and date of the exchange rate, is specified in the Bid Data Sheet.</p> |
| <p>24. Technical Evaluation</p> | <p>24.1 The Employer will carry out a detailed evaluation of the bids previously determined to be substantially responsive in order to determine whether the technical aspects are in accordance with the requirements set forth in the bidding documents. In order to reach such a determination, the Employer will examine and compare the technical aspects of the bids on the basis of the information supplied by the bidders, taking into account the following factors:</p> <ul style="list-style-type: none"> (a) overall completeness and compliance with the Technical Specifications and Drawings; deviations from the Technical Specifications as identified in Attachment 6 to the bid and those deviations not so identified; suitability of the facilities offered in relation to the environmental and climatic conditions prevailing at the site; and quality, function and operation of any process control concept included in the bid. The bid that does not meet minimum acceptable standards of completeness, consistency and detail will be rejected for nonresponsiveness. (b) achievement of specified performance criteria by the facilities |

| | |
|---|--|
| | <p>(c) type, quantity and long-term availability of mandatory and recommended spare parts and maintenance services</p> <p>(d) any other relevant factors, if any, listed in the Bid Data Sheet, or that the Employer deems necessary or prudent to take into consideration.</p> <p>24.2 Where alternative technical solutions have been permitted and offered in Attachment 7 to the bid, the Employer will make a similar evaluation of the alternatives, which will be treated in the technical and commercial evaluations as if they were base bids. Where alternatives are not permitted, but have in any event been offered, they shall be ignored.</p> |
| <p>25. Commercial Evaluation</p> | <p>25.1 The comparison shall be of the EXW price of plant and equipment offered from within the Employer's country, such price to include all costs as well as duties and taxes paid or payable on components and raw material incorporated or to be incorporated in the plant and equipment, with the price of the CIF-named port of destination (or CIP border point or CIP-named place of destination) offered from outside the Employer's country, plus the cost of local transportation, all installation and other services required under the contract. The Employer's comparison will also include the costs resulting from application of the evaluation procedures described in ITB Sub-Clause 25.3.</p> <p>25.2 The Employer's evaluation of a bid will take into account, in addition to the bid prices indicated in Price Schedule Nos. 1 through 5, the following costs and factors that will be added to each Bidder's bid price in the evaluation using pricing information available to the Employer, in the manner and to the extent indicated in ITB Sub-Clause 25.3 and in the Technical Specifications:</p> <p>(a) the cost of all quantifiable deviations and omissions from the contractual and commercial conditions and the Technical Specifications as identified in Attachment 6 to the bid, and other deviations and omissions not so identified</p> <p>(b) compliance with the time schedule called for in the corresponding Appendix to the Form of Contract Agreement and evidenced as needed in a milestone schedule provided in the bid</p> |

| | |
|--|--|
| | <p>(c) the projected operating and maintenance costs during the life of the facilities</p> <p>(d) the functional guarantees of the facilities offered</p> <p>(e) the extra cost of work, services, facilities, etc., required to be provided by the Employer or third parties.</p> <p>The estimated effect of the price adjustment provisions of the Conditions of Contract, applied over the period of execution of the contract, shall not be taken into account in bid evaluation.</p> <p>25.3 Pursuant to ITB Sub-Clause 25.2, the following evaluation methods will be followed:</p> <p>(a) <i>Contractual and commercial deviations</i> The evaluation shall be based on the evaluated cost of fulfilling the contract in compliance with all commercial, contractual and technical obligations under this bidding document. In arriving at the evaluated cost, the price for withdrawal of deviations shown in Attachment 6 of the bid will be used, if necessary. If such a price is not given, the Employer will make its own assessment of the cost of such a deviation for the purpose of ensuring fair comparison of bids.</p> <p>(b) <i>Time schedule (program of performance)</i> The plant and equipment covered by this bidding are required to be shipped and installed, and the facilities shall have the precommissioning completed within the period named in the Bid Data Sheet after the effective date specified in the Form of Contract Agreement. Bidders are required to base their prices on the time schedule given in the corresponding Appendix to the Form of Contract Agreement (Time Schedule) or, where no time schedule is given, on the completion date(s) given in the Bid Data Sheet. No credit will be given for earlier completion. Where an Alternative Time Schedule is accepted, pursuant to ITB Sub-Clause 9.3 (g) (i), and where the completion date offered is within the limits specified in the Bid Data Sheet, bids offering a completion date beyond the minimum designated period shall be adjusted in the evaluation by adding a factor specified in the Bid Data Sheet to the bid price. Bids offering a completion date beyond the maximum designated period shall be rejected.</p> |
|--|--|

| | |
|--|---|
| | <p>(c) <i>Operating and maintenance costs</i></p> <p>(i) Since the operating and maintenance costs of the facilities being procured form a major part of the life cycle cost of the facilities, these costs will be evaluated according to the principles given in the Bid Data Sheet, including the cost of spare parts for the initial period of operation stated in the Bid Data Sheet and based on prices furnished by each Bidder in Price Schedule Nos. 1 and 2, as well as on past experience of the Employer or other employers similarly placed. Such costs shall be added to the bid price for evaluation.</p> <p>(ii) The price of recommended spare parts quoted in Price Schedule No. 6 shall not be considered for evaluation.</p> <p>(d) <i>Functional Guarantees of the facilities</i></p> <p>(i) Bidders shall state the functional guarantees (e.g., performance, efficiency, consumption) of the proposed facilities in response to the Technical Specifications. Plant and equipment offered shall have a minimum (or a maximum, as the case may be) level of functional guarantees specified in the Technical Specifications to be considered responsive. Bids offering plant and equipment with functional guarantees less (or more) than the minimum (or maximum) specified shall be rejected.</p> <p>(ii) For the purposes of evaluation, the adjustment specified in the Bid Data Sheet will be added to the bid price for each drop (or excess) in the responsive functional guarantees offered by the Bidder, below (or above) either a norm of one hundred (100) or the value committed in the responsive bid with the most performing functional guarantees, as specified in the Bid Data Sheet.</p> <p>(e) <i>Work, services, facilities, etc., to be provided by the Employer</i></p> <p>Where bids include the undertaking of work or the provision of services or facilities by the Employer in excess of the provisions allowed for in the bidding documents, the Employer shall assess the costs of such additional work,</p> |
|--|---|

| | |
|------------------------------------|--|
| | <p>services and/or facilities during the duration of the contract. Such costs shall be added to the bid price for evaluation.</p> <p>(f) <i>Specific additional criteria</i> The relevant evaluation method, if any, shall be detailed in the Bid Data Sheet and/or in the Technical Specifications.</p> <p>25.4 Any adjustments in price that result from the above procedures shall be added, for purposes of comparative evaluation only, to arrive at an “Evaluated Bid Price.” Bid prices quoted by bidders shall remain unaltered.</p> |
| 26. Domestic Preference | <p>26.1 In the evaluation and comparison of bids, the CIF or CIP price of plant and equipment to be incorporated in the facilities and proposed to be supplied from abroad as identified in ITB Sub-Clause 11.4 (a) will be increased by the applicable import tariff (custom duties and other import taxes) for the specific plant or equipment in question or by fifteen percent (15%), whichever is less. In the case of more than one import tariff, the appropriate tariff for each item of plant and equipment shall apply. No margin of preference will be allowed for any other component.</p> |
| 27. Contacting the Employer | <p>27.1 From the time of bid opening to the time of contract award, if any Bidder wishes to contact the Employer on any matter related to its bid, it should do so in writing.</p> <p>27.2 Any effort by a Bidder to influence the Employer in the Employer’s bid evaluation, bid comparison or contract award decisions may result in rejection of the Bidder’s bid.</p> |

F. Award of Contract

| | |
|-------------------------------|--|
| 28. Post-qualification | <p>28.1 In the absence of prequalification, the Employer will determine to its satisfaction whether the Bidder selected as having submitted the lowest evaluated responsive bid is qualified to satisfactorily perform the contract.</p> <p>28.2 The determination will take into account the Bidder’s financial, technical and production capabilities, in particular the Bidder’s contract work in hand, future commitments and current litigation. It will be based upon an examination of the documentary evidence of the Bidder’s qualifications submitted by the Bidder in Attachment 3 to the bid, as well as such other information as the Employer deems necessary and appropriate.</p> |
|-------------------------------|--|

| | |
|--|---|
| | <p>28.3 An affirmative determination will be a prerequisite for award of the contract to the Bidder. A negative determination will result in rejection of the Bidder's bid, in which event the Employer will proceed to the next lowest evaluated bid to make a similar determination of that Bidder's capabilities to perform satisfactorily.</p> <p>28.4 The capabilities of the vendors and subcontractors proposed in Attachment 5 to the bid to be used by the lowest evaluated Bidder will also be evaluated for acceptability. Their participation should be confirmed with a letter of intent between the parties, as needed. Should a vendor or subcontractor be determined to be unacceptable, the bid will not be rejected, but the Bidder will be required to substitute an acceptable vendor or subcontractor without any change to the bid price.</p> |
| <p>29. Award Criteria</p> | <p>29.1 Subject to ITB Clause 30, the Employer will award the contract to the successful Bidder whose bid has been determined to be substantially responsive and to be the lowest evaluated bid, further provided that the Bidder is determined to be qualified to perform the contract satisfactorily.</p> <p>29.2 The Employer may request the Bidder to withdraw any of the deviations listed in Attachment 6 to the winning bid, at the price shown for the deviation in Attachment 6 to the bid.</p> |
| <p>30. Employer's Right to Accept Any Bid and to Reject Any or All Bids</p> | <p>30.1 The Employer reserves the right to accept or reject any bid, and to annul the bidding process and reject all bids at any time prior to award of contract, without thereby incurring any liability to the affected Bidder or bidders or any obligation to inform the affected Bidder or bidders of the grounds for the Employer's action.</p> |
| <p>31. Notification of Award</p> | <p>31.1 Prior to the expiration of the period of bid validity, the Employer will notify the successful Bidder in writing by registered letter or by cable, to be confirmed in writing by registered letter, that its bid has been accepted. The notification of award will constitute the formation of the contract.</p> <p>31.2 Upon the successful Bidder's furnishing of the performance security pursuant to ITB Clause 33, the Employer will promptly notify each unsuccessful Bidder and will discharge its bid security, pursuant to ITB Sub-Clause 13.4.</p> |
| <p>32. Signing the</p> | <p>32.1 At the same time as the Employer notifies the successful Bidder</p> |

| | |
|--|---|
| Contract Agreement | <p>that its bid has been accepted, the Employer will send the Bidder the Contract Agreement provided in the bidding documents, incorporating all agreements between the parties.</p> <p>32.2 Within twenty-eight (28) days of receipt of the Contract Agreement, the successful Bidder shall sign and date the Contract Agreement and return it to the Employer.</p> |
| 33. Performance Security | <p>33.1 Within twenty-eight (28) days after receipt of the notification of award, the successful Bidder shall furnish the performance security in the amount given in the Bid Data Sheet and in the form provided in Section VII, Sample Forms and Procedures, of the bidding documents or in another form acceptable to the Employer.</p> <p>33.2 Failure of the successful Bidder to comply with the requirements of ITB Clause 32 or Clause 33 shall constitute sufficient grounds for the annulment of the award and forfeiture of the bid security, in which event the Employer may make the award to the next lowest evaluated Bidder or call for new bids.</p> |
| 34. Adjudicator | <p>34.1 The Employer proposes that the person named in the Bid Data Sheet be appointed as Adjudicator under the contract, at an hourly fee stated in the Bid Data Sheet. A résumé of the named person is attached to the Bid Data Sheet, as well as a description of the expenses that would be considered reimbursable. If a Bidder does not accept the Adjudicator proposed by the Employer, it should so state in its Bid Form and make a counterproposal of an Adjudicator and an hourly fee. If on the day the Contract Agreement is signed, the Employer and the Contractor have not agreed on the appointment of the Adjudicator, the Adjudicator shall be appointed, at the request of either party, by the Appointing Authority specified in the Special Conditions of Contract, pursuant to GCC Sub-Clause 6.1.4.</p> |
| 35. Corrupt or Fraudulent Practices | <p>35.1 The Employer requires that Borrowers, as well as bidders/Suppliers/Contractors under financed contracts, observe the highest standard of ethics during the procurement and execution of such contracts. In pursuance of this policy, the Employer:</p> <p>(a) defines, for the purposes of this provision, the terms set forth below as follows:</p> <p>(i) “corrupt practice” means the offering, giving, receiving or soliciting of any thing of value to</p> |

| | |
|--|--|
| | <p>influence the action of a public official in the procurement process or in contract execution; and</p> <p>(ii) “fraudulent practice” means a misrepresentation of facts in order to influence a procurement process or the execution of a contract to the detriment of the Employer, and includes collusive practice among bidders (prior to or after bid submission) designed to establish bid prices at artificial non-competitive levels and to deprive the Employer of the benefits of free and open competition;</p> <p>(b) will reject a proposal for award if it determines that the Bidder recommended for award has engaged in corrupt or fraudulent practices in competing for the contract in question;</p> <p>(c) will declare a firm ineligible, either indefinitely or for a stated period of time, to be awarded a Employer-financed contract if it at any time determines that the firm has engaged in corrupt or fraudulent practices in competing for, or in executing, a Employer-financed contract.</p> |
| | <p>35.2 Furthermore, bidders shall be aware of the provision stated in Sub-Clause 9.6 and Sub-Clause 42.2 of the General Conditions of Contract.</p> |

Section III. Bid Data Sheet

Bid Data Sheet

The following bid-specific data for the plant and equipment to be procured shall amend and/or supplement the provisions in the Instructions to Bidders (ITB). Whenever there is a conflict, the provisions herein shall prevail over those in the ITB.

[The notes in italics provide instructions for completing the Bid Data Sheet for the relevant ITB Clauses.]

| INTRODUCTION | |
|---------------------|--|
| ITB 1.1 | Name of Project: Design, Manufacture, Supply, Installation and Commissioning of Different Capacity Roof Top Solar Photo Voltaic Power Projects on Government Buildings (22 Locations) under Net Metering Policy in Visakhapatnam City under implementation of Smart City Mission |
| ITB 2.1 | Name of Employer: Greater Visakhapatnam Smart City Corporation Limited (GVSCCL) |
| ITB 6.1 | Address of Employer; telephone, telex and facsimile numbers Attention: <i>Managing Director</i> Address: Greater Visakhapatnam Smart City Corporation Limited (GVSCCL), C/o Greater Visakhapatnam Municipal Corporation Tenneti Bhavan, Ram Nagar, City: Visakhapatnam PIN Code: 530003 Country: India <i>Telephone: : +91 - 891 - 2746301-7</i> <i>Facsimile number: +91-891-2568545</i> Requests for clarification should be received by the Employer no later than: 15 days. <i>All the Clarification issued will be vide web portal only.</i> |
| ITB 6.4 | Pre bid meeting on date 15 May 2017 at 1600 hrs Venue- Tenneti Bhavan, Ram Nagar, City: Visakhapatnam PIN Code: 530003 Country: India <i>Telephone: : +91 - 891 - 2746301-7</i> <i>Facsimile number: +91-891-2568545</i> |
| ITB 8.1 | Language of bid is English |
| ITB 9.3 (c) & (e) | Qualification requirements for bidders, including members of joint |

| | |
|--|--|
| | <p>ventures, subcontractors or vendors</p> <p>The applicant shall meet the following minimum criteria:</p> <p>a) Average Annual Turnover</p> <p style="padding-left: 40px;">Average Annual turnover in last 5 years (five years) equal to Rs. 4.0 Crores</p> <p>b) Experience in similar works</p> <ul style="list-style-type: none">• Bidders should have sufficient experience of design, manufacturing, supplying, installing, commissioning and maintaining at least SPV Power Plants of aggregate capacity 560 KWp in last three years up to the last date of bidding and is in successful operation in India. Bidder is required to submit the proof of their eligibility in the form of work order, commissioning certificate from the Client, satisfactory operation reports copies and establishment details along with the tender bid in its technical bid.• The company or authorized supplier shall have minimum 2 years' experience in installation of Solar power projects as on March 31st 2017.• The company / supplier should be in profit for at least two financial years out of the last three financial years i.e. 2013-14, 2014-15 & 2015-16.• The SPV modules shall be warranted for 25 years and complete SPV systems including batteries would be warranted by the manufacturer for five years, from the date of commissioning of the Project. After Installation & Commissioning Solar roof top power project shall be jointly visited by a committee of supplier, user and District Officer of GVSSCL.• Material shall be strictly as per laid down specifications and if there is any left out specification, in the Information Document the same shall be considered as per the latest MNRE & SECI specifications and guidelines. <p>The works may have been executed by the Applicant as prime contractor or as a member of Joint Venture or Sub-Contractor. As sub-contractor, he should have acquired the experience of execution of all major items of works under the proposed contract. In case a project has been executed by a joint venture, weightage towards</p> |
|--|--|

| | |
|------------------|--|
| | <p>experience of the project would be given to each joint venture in proportion to their participation in the joint venture.</p> <p>Please note that if the applicant intends to showcase the qualification criteria from its experience as subcontractor, the applicant has to attach the Certificate in support which has been issued by the Prime / Main Client of rank not less than Executive Engineer or equivalent.</p> |
| ITB 9.3 (d) (ii) | Spares required for operation; number of years following completion |
| ITB 9.3 (g) | Alternative bids are accepted under Item (i) and/or (iii). |

| BID PRICE AND CURRENCY | |
|-------------------------------|---|
| ITB 11.6 | The price shall be fixed |
| ITB 12.1 (b) | ITB Sub-Clause 12.1 (b) is not applicable. Instead, the choice of currencies in ITB Sub-Clause 12.1 (a) shall apply to all plant and equipment. |
| ITB 12.1 (c) | ITB Sub-Clause 12.1 (c) is not applicable. Instead, the choice of currencies in ITB Sub-Clause 12.1 (a) shall apply to all services referred to in ITB Sub-Clause 12.1 (c). |

| BID PREPARATION AND SUBMISSION | |
|---------------------------------------|---|
| ITB 13.1 | Amount of bid security(EMD)- INR 8.00 Lacs |
| ITB 14.1 | Bid validity period- 120 days |
| ITB 15.1 & 19.2 | <p>The following shall be submitted online in www.apecurement.gov.in</p> <ul style="list-style-type: none"> • Technical Proposal containing all the required documents in the required formats. 2 copies (hard bound) of Uploaded technical proposal shall be submitted to the office of the Employer, as mentioned in the RFP. • Priced Bill of Quantities. The Priced Bid shall be uploaded through web-portal only. If the Price Bid is submitted in the form of Hard Copy, the Bid will treated as non-responsive. |
| ITB 17.1 | <p>Last date of submission of bid –25 May 2017 upto 1700Hrs</p> <p>Bid submission address –</p> <p>Attention: <i>Managing Director</i></p> |

| | |
|----------|---|
| | <p>Address: Greater Visakhapatnam Smart City Corporation Limited (GVSCCL), C/o Greater Visakhapatnam Municipal Corporation Tenneti Bhavan, Ram Nagar, City: Visakhapatnam PIN Code: 530003 Country: India Telephone: : +91 - 891 - 2746301-7 Facsimile number: +91-891-2568545</p> |
| ITB 20.1 | <p>The bid opening shall take place at: Tenneti Bhavan, Ram Nagar, City: Visakhapatnam PIN Code: 530003 Country: India Date: 25 May 2017 (Technical Bid). Time: 1800 Hrs</p> |

| BID EVALUATION | |
|-----------------------|---|
| | |
| ITB 23.2 | <p>Currency chosen for the purpose of converting to a common currency</p> <p>Source of exchange rate; Reserve Bank of India Date of exchange rate: 30 days before the deadline of the submission of the bid.</p> |
| ITB 24.1 (d) | <p>The following additional criteria will be used in the evaluation in the manner stated and to the extent indicated in the Bid Data Sheet under ITB Sub-Clause 25.3 (f);</p> <ul style="list-style-type: none"> (a) Copies of original documents defining the constitution or legal status, place of registration, and principal place of business; written power of attorney of the signatory of the Bid to commit the Bidder; (b) Total monetary value of similar work performed for each of the last five years; (c) Experience in works of similar nature and size for each of the last five years, and details of works underway or contractually committed with their certificates from the concerned officer not less the rank of Executive Engineer or Equivalent. A list of clients with their contact details, who may be contacted for further information on those contracts, |

| | |
|--------------|---|
| | <p>shall also be provided.</p> <p>(d) Major items of construction equipment proposed to carry out the Contract;</p> <p>(e) Qualifications and experience of key site management and technical personnel proposed for Contract;</p> <p>Reports on the financial standing of the Bidder, such as profit and loss statements and auditor's reports for the past five years;</p> <p>(f) Evidence of access to line (s) of credit and availability of other financial resources facilities (20% of contract value), certified by the Bankers (Not more than 3 months old) for proposed work.</p> <p>(g) Undertaking that the bidder will be able to invest a minimum cash upto 25% of contract value of work, during implementation of work.</p> <p>(h) Authority may seek references from the Bidder's bankers;</p> <p>(i) Information regarding any litigation, current or during the last five years, in which the Bidder is involved, the parties concerned, and disputed Amount</p> <p>(j) Proposal, if any, for subcontracting of elements of work. Such subcontracting shall not be permissible for more than <u>10% (Ten percent) and until and unless Greater Visakhapatnam Smart City Corporation Limited approve the same and issue order in this regard.</u></p> |
| ITB 25.3 (b) | Time schedule: 6 months |

| | |
|--------------|--|
| ITB 25.3 (f) | <p>In addition to above, each bidder to be eligible or qualify should have submitted/ attached with his technical bid</p> <p>(i) The proof of PAN issued by Income Tax Department.</p> <p>(ii) An Affidavit/ undertaking (self-declaration) of not having been black-listed/debarred by any Govt. / Semi Govt. Organization / Corporation / Greater Visakhapatnam Smart City Corporation Limited at any stage.</p> <p>(iii) An affidavit / undertaking (self-declaration) that information being submitted is correct and true, and that any false information shall lead to disqualification at any stage;</p> <p>(iv) The proof of his valid VAT Registration Number (TIN) issued by concerned department.</p> <p>(v) The proof of his valid EPF registration with the Provident</p> |
|--------------|--|

| | |
|--|--|
| | <p>Commissioner.</p> <p>(vi) An undertaking that he agrees to the terms and conditions of bidding document including the technical requirements and in case there is anything contradictory in his technical proposal with respect to the conditions of bidding document, the latter shall prevail.</p> <p>(vii) The undertaking / affidavit / documentary proofs required as per the qualifying conditions laid down in the Conditions of Particular Application.</p> |
|--|--|

| CONTRACT AWARD | |
|-----------------------|---|
| ITB 33 | Amount of performance security - 5% of the accepted Contract Value |
| ITB 34 | <p>Name of the Adjudicator proposed by the Employer – to be decided later</p> <p>Hourly fee for the Adjudicator- To be decided later.</p> |

Section IV. General Conditions of Contract

Table of Clauses

| | |
|---|----|
| A. Contract and Interpretation | 43 |
| 1. Definitions..... | 43 |
| 2. Contract Documents..... | 46 |
| 3. Interpretation..... | 46 |
| 4. Notices | 48 |
| 5. Governing Law | 49 |
| 6. Settlement of Disputes | 49 |
| B. Subject Matter of Contract | 51 |
| 7. Scope of Facilities..... | 51 |
| 8. Time for Commencement and Completion..... | 52 |
| 9. Contractor’s Responsibilities..... | 52 |
| 10. Employer’s Responsibilities | 53 |
| C. Payment | 55 |
| 11. Contract Price..... | 55 |
| 12. Terms of Payment | 55 |
| 13. Securities..... | 56 |
| 14. Taxes and Duties..... | 57 |
| D. Intellectual Property | 58 |
| 15. Copyright | 58 |
| 16. Confidential Information..... | 58 |
| E. Execution of the Facilities | 59 |
| 17. Representatives | 59 |
| 18. Work Program..... | 61 |
| 19. Subcontracting | 63 |
| 20. Design and Engineering | 63 |
| 21. Procurement | 66 |
| 22. Installation..... | 68 |
| 23. Test and Inspection | 72 |
| 24. Completion of the Facilities..... | 74 |
| 25. Commissioning and Operational Acceptance..... | 76 |
| F. Guarantees and Liabilities | 78 |
| 26. Completion Time Guarantee..... | 78 |
| 27. Defect Liability | 79 |
| 28. Functional Guarantees..... | 82 |
| 29. Patent Indemnity | 83 |
| 30. Limitation of Liability..... | 84 |

| | |
|--|-----|
| G. Risk Distribution | 84 |
| 31. Transfer of Ownership | 84 |
| 32. Care of Facilities | 85 |
| 33. Loss of or Damage to Property; Accident or Injury to Workers; Indemnification | 86 |
| 34. Insurance | 88 |
| 35. Unforeseen Conditions..... | 90 |
| 36. Change in Laws and Regulations..... | 92 |
| 37. Force Majeure | 92 |
| 38. War Risks..... | 94 |
| | |
| H. Change in Contract Elements | 97 |
| 39. Change in the Facilities..... | 97 |
| 40. Extension of Time for Completion | 100 |
| 41. Suspension | 101 |
| 42. Termination..... | 103 |
| 43. Assignment | 111 |

General Conditions of Contract

A. Contract and Interpretation

1. Definitions

1.1 The following words and expressions shall have the meanings hereby assigned to them:

“Contract” means the Contract Agreement entered into between the Employer and the Contractor, together with the Contract Documents referred to therein; they shall constitute the Contract, and the term “the Contract” shall in all such documents be construed accordingly.

“Contract Documents” means the documents listed in Article 1.1 (Contract Documents) of the Form of Contract Agreement (including any amendments thereto).

“GCC” means the General Conditions of Contract hereof.

“SCC” means the Special Conditions of Contract.

“Day” means calendar day of the Gregorian Calendar.

“Month” means calendar month of the Gregorian Calendar.

“Employer” means the person named as such in the SCC and includes the legal successors or permitted assigns of the Employer.

“Project Manager” means the person appointed by the Employer in the manner provided in GCC Sub-Clause 17.1 (Project Manager) hereof and named as such in the SCC to perform the duties delegated by the Employer.

“Contractor” means the person(s) whose bid to perform the Contract has been accepted by the Employer and is named as such in the Contract Agreement, and includes the legal successors or permitted assigns of the Contractor.

“Contractor’s Representative” means any person nominated by the Contractor and named as such in the SCC and approved by the Employer in the manner provided in GCC Sub-Clause 17.2 (Contractor’s Representative and Construction Manager) hereof

to perform the duties delegated by the Contractor.

“Subcontractor,” including vendors, means any person to whom execution of any part of the Facilities, including preparation of any design or supply of any Plant and Equipment, is sub-contracted directly or indirectly by the Contractor, and includes its legal successors or permitted assigns.

“Adjudicator” means the person or persons named as such in the SCC appointed by agreement between the Employer and the Contractor to make a decision on or to settle any dispute or difference between the Employer and the Contractor referred to him or her by the parties pursuant to GCC Sub-Clause 6.1 (Adjudicator) hereof.

“Contract Price” means the sum specified in Article 2.1 (Contract Price) of the Contract Agreement, subject to such additions and adjustments thereto or deductions therefrom, as may be made pursuant to the Contract.

“Facilities” means the Plant and Equipment to be supplied and installed, as well as all the Installation Services to be carried out by the Contractor under the Contract.

“Plant and Equipment” means permanent plant, equipment, machinery, apparatus, articles and things of all kinds to be provided and incorporated in the Facilities by the Contractor under the Contract (including the spare parts to be supplied by the Contractor under GCC Sub-Clause 7.3 hereof), but does not include Contractor’s Equipment.

“Installation Services” means all those services ancillary to the supply of the Plant and Equipment for the Facilities, to be provided by the Contractor under the Contract; e.g., transportation and provision of marine or other similar insurance, inspection, expediting, site preparation works (including the provision and use of Contractor’s Equipment and the supply of all construction materials required), installation, testing, precommissioning, commissioning, operations, maintenance, the provision of operations and maintenance manuals, training, etc.

“Contractor’s Equipment” means all plant, facilities, equipment, machinery, tools, apparatus, appliances or things of every kind required in or for installation, completion and maintenance of Facilities that are to be provided by the Contractor, but does not include Plant and Equipment, or other things intended to form or

forming part of the Facilities.

“Country of Origin” means the countries and territories eligible under the State rules of the as further elaborated in the SCC.

“Site” means the land and other places upon which the Facilities are to be installed, and such other land or places as may be specified in the Contract as forming part of the Site.

“Effective Date” means the date of fulfillment of all conditions stated in Article 3 (Effective Date for Determining Time for Completion) of the Form of Contract Agreement, for the purpose of determining the Time for Completion.

“Time for Completion” means the time within which Completion of the Facilities as a whole (or of a part of the Facilities where a separate Time for Completion of such part has been prescribed) is to be attained in accordance with the specifications in the SCC and the relevant provisions of the Contract.

“Completion” means that the Facilities (or a specific part thereof where specific parts are specified in the SCC) have been completed operationally and structurally and put in a tight and clean condition, and that all work in respect of Precommissioning of the Facilities or such specific part thereof has been completed; in other words, that the Facilities or specific part thereof are ready for Commissioning as provided in GCC Clause 24 (Completion) hereof.

“Precommissioning” means the testing, checking and other requirements specified in the Technical Specifications that are to be carried out by the Contractor in preparation for Commissioning as provided in GCC Clause 24 (Completion) hereof.

“Commissioning” means operation of the Facilities or any part thereof by the Contractor following Completion, which operation is to be carried out by the Contractor as provided in GCC Sub-Clause 25.1 (Commissioning) hereof, for the purpose of carrying out Guarantee Test(s).

“Guarantee Test(s)” means the test(s) specified in the Technical Specifications to be carried out to ascertain whether the Facilities or a specified part thereof is able to attain the Functional Guarantees specified in the Technical Specifications in

accordance with the provisions of GCC Sub-Clause 25.2 (Guarantee Test) hereof.

“Operational Acceptance” means the acceptance by the Employer of the Facilities (or any part of the Facilities where the Contract provides for acceptance of the Facilities in parts), which certifies the Contractor’s fulfillment of the Contract in respect of Functional Guarantees of the Facilities (or the relevant part thereof) in accordance with the provisions of GCC Clause 28 (Functional Guarantees) hereof and shall include deemed acceptance in accordance with GCC Clause 25 (Commissioning and Operational Acceptance) hereof.

“Defect Liability Period” means the period of validity of the warranties given by the Contractor commencing at Completion of the Facilities or a part thereof, during which the Contractor is responsible for defects with respect to the Facilities (or the relevant part thereof) as provided in GCC Clause 27 (Defect Liability) hereof.

- 2. Contract Documents** 2.1 Subject to Article 1.2 (Order of Precedence) of the Contract Agreement, all documents forming part of the Contract (and all parts thereof) are intended to be correlative, complementary and mutually explanatory. The Contract shall be read as a whole.
- 3. Interpretation** 3.1 Language
- 3.1.1 Unless the Contractor is a national of the Employer’s country and the Employer and the Contractor agree to use the national language, all Contract Documents, all correspondence and communications to be given, and all other documentation to be prepared and supplied under the Contract shall be written in English, and the Contract shall be construed and interpreted in accordance with that language.
- 3.1.2 If any of the Contract Documents, correspondence or communications are prepared in any language other than the governing language under GCC Sub-Clause 3.1.1 above, the English translation of such documents, correspondence or communications shall prevail in matters of interpretation.
- 3.2 Singular and Plural
The singular shall include the plural and the plural the singular, except where the context otherwise requires.

3.3 Headings

The headings and marginal notes in the General Conditions of Contract are included for ease of reference, and shall neither constitute a part of the Contract nor affect its interpretation.

3.4 Persons

Words importing persons or parties shall include firms, corporations and government entities.

3.5 Incoterms

Unless inconsistent with any provision of the Contract, the meaning of any trade term and the rights and obligations of parties thereunder shall be as prescribed by *Incoterms*.

Incoterms means international rules for interpreting trade terms published by the International Chamber of Commerce (latest edition), 38 Cours Albert 1^{er}, 75008 Paris, France.

3.6 Entire Agreement

Subject to GCC Sub-Clause 16.4 hereof, the Contract constitutes the entire agreement between the Employer and Contractor with respect to the subject matter of Contract and supersedes all communications, negotiations and agreements (whether written or oral) of parties with respect thereto made prior to the date of Contract.

3.7 Amendment

No amendment or other variation of the Contract shall be effective unless it is in writing, is dated, expressly refers to the Contract, and is signed by a duly authorized representative of each party hereto.

3.8 Independent Contractor

The Contractor shall be an independent contractor performing the Contract. The Contract does not create any agency, partnership, joint venture or other joint relationship between the parties hereto.

Subject to the provisions of the Contract, the Contractor shall be solely responsible for the manner in which the Contract is performed. All employees, representatives or Subcontractors engaged by the Contractor in connection with the performance of the Contract shall be under the complete control of the Contractor and shall not be deemed to be employees of the Employer, and nothing contained in the Contract or in any

subcontract awarded by the Contractor shall be construed to create any contractual relationship between any such employees, representatives or Subcontractors and the Employer.

3.9 Joint Venture or Consortium

If the Contractor is a joint venture or consortium of two or more persons, all such firms shall be jointly and severally bound to the Employer for the fulfillment of the provisions of the Contract and shall designate one of such persons to act as a leader with authority to bind the joint venture or consortium. The composition or the constitution of the joint venture or consortium shall not be altered without the prior consent of the Employer.

3.10 Non-Waiver

3.10.1 Subject to GCC Sub-Clause 3.10.2 below, no relaxation, forbearance, delay or indulgence by either party in enforcing any of the terms and conditions of the Contract or the granting of time by either party to the other shall prejudice, affect or restrict the rights of that party under the Contract, nor shall any waiver by either party of any breach of Contract operate as waiver of any subsequent or continuing breach of Contract.

3.10.2 Any waiver of a party's rights, powers or remedies under the Contract must be in writing, must be dated and signed by an authorized representative of the party granting such waiver, and must specify the right and the extent to which it is being waived.

3.11 Severability

If any provision or condition of the Contract is prohibited or rendered invalid or unenforceable, such prohibition, invalidity or unenforceability shall not affect the validity or enforceability of any other provisions and conditions of the Contract.

3.12 Country of Origin

"Origin" means the place where the materials, equipment and other supplies for the Facilities are mined, grown, produced or manufactured, and from which the services are provided.

4. Notices

4.1 Unless otherwise stated in the Contract, all notices to be given under the Contract shall be in writing, and shall be sent by personal delivery, airmail post, special courier, cable, telegraph, telex, facsimile or Electronic Data Interchange (EDI) to the address of the relevant party set out in the SCC, with the

following provisions:

4.1.1 Any notice sent by cable, telegraph, telex, facsimile or EDI shall be confirmed within two (2) days after dispatch by notice sent by airmail post or special courier, except as otherwise specified in the Contract.

4.1.2 Any notice sent by airmail post or special courier shall be deemed (in the absence of evidence of earlier receipt) to have been delivered ten (10) days after dispatch. In proving the fact of dispatch, it shall be sufficient to show that the envelope containing such notice was properly addressed, stamped and conveyed to the postal authorities or courier service for transmission by airmail or special courier.

4.1.3 Any notice delivered personally or sent by cable, telegraph, telex, facsimile or EDI shall be deemed to have been delivered on date of its dispatch.

4.1.4 Either party may change its postal, cable, telex, facsimile or EDI address or addressee for receipt of such notices by ten (10) days' notice to the other party in writing.

4.2 Notices shall be deemed to include any approvals, consents, instructions, orders and certificates to be given under the Contract.

5. Governing Law

5.1 The Contract shall be governed by and interpreted in accordance with laws of the country specified in the SCC.

6. Settlement of Disputes

6.1 Adjudicator

6.1.1 If any dispute of any kind whatsoever shall arise between the Employer and the Contractor in connection with or arising out of the Contract, including without prejudice to the generality of the foregoing, any question regarding its existence, validity or termination, or the execution of the Facilities—whether during the progress of the Facilities or after their completion and whether before or after the termination, abandonment or breach of the Contract—the parties shall seek to resolve any such dispute or difference by mutual consultation. If the parties fail to resolve such a dispute or difference by mutual consultation, then the dispute shall be referred in writing by either party to the Adjudicator, with a copy to the other party.

- 6.1.2 The Adjudicator shall give its decision in writing to both parties within twenty-eight (28) days of a dispute being referred to it. If the Adjudicator has done so, and no notice of intention to commence arbitration has been given by either the Employer or the Contractor within fifty-six (56) days of such reference, the decision shall become final and binding upon the Employer and the Contractor. Any decision that has become final and binding shall be implemented by the parties forthwith.
- 6.1.3 The Adjudicator shall be paid an hourly fee at the rate specified in the SCC plus reasonable expenditures incurred in the execution of its duties as Adjudicator, and these costs shall be divided equally between the Employer and the Contractor.
- 6.1.4 Should the Adjudicator resign or die, or should the Employer and the Contractor agree that the Adjudicator is not fulfilling its functions in accordance with the provisions of the Contract, a new Adjudicator shall be jointly appointed by the Employer and the Contractor. Failing agreement between the two within twenty-eight (28) days, the new Adjudicator shall be appointed at the request of either party by the Appointing Authority specified in the SCC.

6.2 Arbitration

- 6.2.1 If either the Employer or the Contractor is dissatisfied with the Adjudicator's decision, or if the Adjudicator fails to give a decision within twenty-eight (28) days of a dispute being referred to it, then either the Employer or the Contractor may, within fifty-six (56) days of such reference, give notice to the other party, with a copy for information to the Adjudicator, of its intention to commence arbitration, as hereinafter provided, as to the matter in dispute, and no arbitration in respect of this matter may be commenced unless such notice is given.
- 6.2.2 Any dispute in respect of which a notice of intention to commence arbitration has been given, in accordance with GCC Sub-Clause 6.2.1, shall be finally settled by arbitration. Arbitration may be commenced prior to or after completion of the Facilities.
- 6.2.3 Arbitration proceedings shall be conducted in accordance

with the rules of procedure designated in the SCC.

- 6.3 Notwithstanding any reference to the Adjudicator or arbitration herein,
- (a) the parties shall continue to perform their respective obligations under the Contract unless they otherwise agree
 - (b) the Employer shall pay the Contractor any monies due the Contractor.

B. Subject Matter of Contract

7. Scope of Facilities

- 7.1 Unless otherwise expressly limited in the Technical Specifications, the Contractor's obligations cover the provision of all Plant and Equipment and the performance of all Installation Services required for the design, the manufacture (including procurement, quality assurance, construction, installation, associated civil works, Precommissioning and delivery) of the Plant and Equipment and the installation, completion and commissioning of the Facilities in accordance with the plans, procedures, specifications, drawings, codes and any other documents as specified in the Technical Specifications. Such specifications include, but are not limited to, the provision of supervision and engineering services; the supply of labor, materials, equipment, spare parts (as specified in GCC Sub-Clause 7.3 below) and accessories; Contractor's Equipment; construction utilities and supplies; temporary materials, structures and facilities; transportation (including, without limitation, unloading and hauling to, from and at the Site); and storage, except for those supplies, works and services that will be provided or performed by the Employer, as set forth in the corresponding Appendix (Scope of Works and Supply by the Employer) to the Contract Agreement.
- 7.2 The Contractor shall, unless specifically excluded in the Contract, perform all such work and/or supply all such items and materials not specifically mentioned in the Contract but that can be reasonably inferred from the Contract as being required for attaining Completion of the Facilities as if such work and/or items and materials were expressly mentioned in the Contract.
- 7.3 In addition to the supply of Mandatory Spare Parts included in the Contract, the Contractor agrees to supply spare parts required

for the operation and maintenance of the Facilities for the period specified in the Special Conditions of Contract. However, the identity, specifications and quantities of such spare parts and the terms and conditions relating to the supply thereof are to be agreed between the Employer and the Contractor, and the price of such spare parts shall be that given in Price Schedule No. 6, which shall be added to the Contract Price. The price of such spare parts shall include the purchase price therefor and other costs and expenses (including the Contractor's fees) relating to the supply of spare parts.

8. Time for Commencement and Completion

8.1 The Contractor shall commence work on the Facilities within the period specified in the SCC and without prejudice to GCC Sub-Clause 26.2 hereof, the Contractor shall thereafter proceed with the Facilities in accordance with the time schedule specified in the corresponding Appendix (Time Schedule) to the Contract Agreement.

8.2 The Contractor shall attain Completion of the Facilities (or of a part where a separate time for Completion of such part is specified in the Contract) within the time stated in the SCC or within such extended time to which the Contractor shall be entitled under GCC Clause 40 hereof.

9. Contractor's Responsibilities

9.1 The Contractor shall design, manufacture (including associated purchases and/or subcontracting), install and complete the Facilities with due care and diligence in accordance with the Contract.

9.2 The Contractor confirms that it has entered into this Contract on the basis of a proper examination of the data relating to the Facilities (including any data as to boring tests) provided by the Employer, and on the basis of information that the Contractor could have obtained from a visual inspection of the Site (if access thereto was available) and of other data readily available to it relating to the Facilities as of the date twenty-eight (28) days prior to bid submission. The Contractor acknowledges that any failure to acquaint itself with all such data and information shall not relieve its responsibility for properly estimating the difficulty or cost of successfully performing the Facilities.

9.3 The Contractor shall acquire in its name all permits, approvals and/or licenses from all local, state or national government authorities or public service undertakings in the country where the Site is located that are necessary for the performance of the

Contract, including, without limitation, visas for the Contractor's and Subcontractor's personnel and entry permits for all imported Contractor's Equipment. The Contractor shall acquire all other permits, approvals and/or licenses that are not the responsibility of the Employer under GCC Sub-Clause 10.3 hereof and that are necessary for the performance of the Contract.

- 9.4 The Contractor shall comply with all laws in force in the country where the Facilities are installed and where the Installation Services are carried out. The laws will include all local, state, national or other laws that affect the performance of the Contract and bind upon the Contractor. The Contractor shall indemnify and hold harmless the Employer from and against any and all liabilities, damages, claims, fines, penalties and expenses of whatever nature arising or resulting from the violation of such laws by the Contractor or its personnel, including the Subcontractors and their personnel, but without prejudice to GCC Sub-Clause 10.1 hereof.
- 9.5 Any Plant, Material and Services that will be incorporated in or be required for the Facilities and other supplies shall have their origin as specified under GCC Clause 1 (Country of Origin).
- 9.6 The Contractor shall permit the Employer to inspect the Contractor's accounts and records relating to the performance of the Contractor and to have them audited by auditors appointed by the Employer, if so required by the Employer.

**10. Employer's
Responsibilities**

- 10.1 The Employer shall ensure the accuracy of all information and/or data to be supplied by the Employer as described in the corresponding Appendix (Scope of Works and Supply by the Employer) to the Contract, except when otherwise expressly stated in the Contract.
- 10.2 The Employer shall be responsible for acquiring and providing legal and physical possession of the Site and access thereto, and for providing possession of and access to all other areas reasonably required for the proper execution of the Contract, including all requisite rights of way, as specified in the corresponding Appendix (Scope of Works and Supply by the Employer) to the Contract Agreement. The Employer shall give full possession of and accord all rights of access thereto on or before the date(s) specified in that Appendix.
- 10.3 The Employer shall acquire and pay for all permits, approvals

and/or licenses from all local, state or national government authorities or public service undertakings in the country where the Site is located. Such authorities or undertakings require the Employer to obtain them in the Employer's name, are necessary for the execution of the Contract (they include those required for the performance by both the Contractor and the Employer of their respective obligations under the Contract), and are specified in the corresponding Appendix (Scope of Works and Supply by the Employer) to the Contract Agreement.

- 10.4 If requested by the Contractor, the Employer shall use its best endeavors to assist the Contractor in obtaining in a timely and expeditious manner all permits, approvals and/or licenses necessary for the execution of the Contract from all local, state or national government authorities or public service undertakings that such authorities or undertakings require the Contractor or Subcontractors or the personnel of the Contractor or Subcontractors, as the case may be, to obtain.
- 10.5 Unless otherwise specified in the Contract or agreed upon by the Employer and the Contractor, the Employer shall provide sufficient, properly qualified operating and maintenance personnel; shall supply and make available all raw materials, utilities, lubricants, chemicals, catalysts, other materials and facilities; and shall perform all work and services of whatsoever nature, including those required by the Contractor to properly carry out Precommissioning, Commissioning and Guarantee Tests, all in accordance with the provisions of the corresponding Appendix (Scope of Works and Supply by the Employer) to the Contract Agreement at or before the time specified in the program furnished by the Contractor under GCC Sub-Clause 18.2 hereof and in the manner thereupon specified or as otherwise agreed upon by the Employer and the Contractor.
- 10.6 The Employer shall be responsible for the continued operation of the Facilities after Completion, in accordance with GCC Sub-Clause 24.8, and shall be responsible for facilitating the Guarantee Test(s) for the Facilities, in accordance with GCC Sub-Clause 25.2.
- 10.7 All costs and expenses involved in the performance of the obligations under this GCC Clause 10 shall be the responsibility of the Employer, save those to be incurred by the Contractor with respect to the performance of Guarantee Tests, in accordance with GCC Sub-Clause 25.2.

C. Payment

- 11. Contract Price**
- 11.1 The Contract Price shall be as specified in Article 2 (Contract Price and Terms of Payment) of the Form of Contract Agreement.
- 11.2 Unless indicated otherwise in the SCC, the Contract Price shall be a firm lump sum not subject to any alteration, except in the event of a Change in the Facilities or as otherwise provided in the Contract.
- 11.3 Subject to GCC Sub-Clauses 9.2, 10.1 and 35 hereof, the Contractor shall be deemed to have satisfied itself as to the correctness and sufficiency of the Contract Price, which shall, except as otherwise provided for in the Contract, cover all its obligations under the Contract.
- 12. Terms of Payment**
- 12.1 The Contract Price shall be paid as specified in the corresponding Appendix (Terms and Procedures of Payment) to the Contract Agreement. The procedures to be followed in making application for and processing payments shall be those outlined in the same Appendix.
- 12.2 No payment made by the Employer herein shall be deemed to constitute acceptance by the Employer of the Facilities or any part(s) thereof.
- 12.3 In the event that the Employer fails to make any payment by its respective due date or within the period set forth in the Contract, the Employer shall pay to the Contractor interest on the amount of such delayed payment at the rate(s) shown in the corresponding Appendix (Terms and Procedures of Payment) to the Contract Agreement for the period of delay until payment has been made in full, whether before or after judgment or arbitrage award.
- 12.4 The currency or currencies in which payments are made to the Contractor under this Contract shall be specified in the corresponding Appendix (Terms and Procedures of Payment) to the Contract Agreement, subject to the general principle that payments will be made in the currency or currencies in which the Contract Price has been stated in the Contractor's bid.

12.5 All payments shall be made in the currency or currencies specified in the corresponding Appendix (Terms and Procedures of Payment) to the Contract Agreement, pursuant to GCC 12.4.

13. Securities

13.1 Issuance of Securities

The Contractor shall provide the securities specified below in favor of the Employer at the times, and in the amount, manner and form specified below.

13.2 Advance Payment Security

13.2.1 The Contractor shall, within twenty-eight (28) days of the notification of contract award, provide a security in an amount equal to the advance payment calculated in accordance with the corresponding Appendix (Terms and Procedures of Payment) to the Contract Agreement, and in the same currency or currencies.

13.2.2 The security shall be in the form provided in the bidding documents or in another form acceptable to the Employer. The amount of the security shall be reduced in proportion to the value of the Facilities executed by and paid to the Contractor from time to time, and shall automatically become null and void when the full amount of the advance payment has been recovered by the Employer. The security shall be returned to the Contractor immediately after its expiration.

13.3 Performance Security

13.3.1 The Contractor shall, within twenty-eight (28) days of the notification of contract award, provide a security for the due performance of the Contract in the amount specified in the SCC.

13.3.2 The security shall be denominated in the currency or currencies of the Contract, or in a freely convertible currency acceptable to the Employer, and shall be in one of the forms of bank guarantees provided in the bidding documents, as stipulated by the Employer in the SCC, or in another form acceptable to the Employer.

13.3.3 The security shall automatically be reduced by half on the date of the Operational Acceptance and shall become null and void, Six (06) months after Completion of the Facilities or twelve (12) months after Operational Acceptance of the Facilities, whichever occurs first;

provided, however, that if the Defects Liability Period has been extended on any part of the Facilities pursuant to GCC Sub-Clause 27.8 hereof, the Contractor shall issue an additional security in an amount proportionate to the Contract Price of that part. The security shall be returned to the Contractor immediately after its expiration, provided, however, that if the Contractor, pursuant to GCC Sub-Clause 27.10, is liable for an extended warranty obligation, the performance security shall be extended for the period and up to the amount specified in the SCC.

14. Taxes and Duties

- 14.1 Except as otherwise specifically provided in the Contract, the Contractor shall bear and pay all taxes, duties, levies and charges assessed on the Contractor, its Subcontractors or their employees by all municipal, state or national government authorities in connection with the Facilities in and outside of the country where the Site is located.
- 14.2 Notwithstanding GCC Sub-Clause 14.1 above, the Employer shall bear and promptly pay all customs and import duties as well as other local taxes like, e.g., a value added tax (VAT), imposed by the law of the country where the Site is located on the Plant and Equipment specified in Price Schedule No. 1 and that are to be incorporated into the Facilities.
- 14.3 If any tax exemptions, reductions, allowances or privileges may be available to the Contractor in the country where the Site is located, the Employer shall use its best endeavors to enable the Contractor to benefit from any such tax savings to the maximum allowable extent.
- 14.4 For the purpose of the Contract, it is agreed that the Contract Price specified in Article 2 (Contract Price and Terms of Payment) of the Form of Contract Agreement is based on the taxes, duties, levies and charges prevailing at the date twenty-eight (28) days prior to the date of bid submission in the country where the Site is located (hereinafter called "Tax" in this GCC Sub-Clause 14.4). If any rates of Tax are increased or decreased, a new Tax is introduced, an existing Tax is abolished, or any change in interpretation or application of any Tax occurs in the course of the performance of Contract, which was or will be assessed on the Contractor, Subcontractors or their employees in connection with performance of the Contract, an equitable adjustment of the Contract Price shall be made to fully take into account any such change by addition to the Contract Price or

deduction therefrom, as the case may be, in accordance with GCC Clause 36 hereof.

D. Intellectual Property

- 15. Copyright**
- 15.1 The copyright in all drawings, documents and other materials containing data and information furnished to the Employer by the Contractor herein shall remain vested in the Contractor or, if they are furnished to the Employer directly or through the Contractor by any third party, including suppliers of materials, the copyright in such materials shall remain vested in such third party.
- 16. Confidential Information**
- 16.1 The Employer and the Contractor shall keep confidential and shall not, without the written consent of the other party hereto, divulge to any third party any documents, data or other information furnished directly or indirectly by the other party hereto in connection with the Contract, whether such information has been furnished prior to, during or following termination of the Contract. Notwithstanding the above, the Contractor may furnish to its Subcontractor(s) such documents, data and other information it receives from the Employer to the extent required for the Subcontractor(s) to perform its work under the Contract, in which event the Contractor shall obtain from such Subcontractor(s) an undertaking of confidentiality similar to that imposed on the Contractor under this GCC Clause 16.
- 16.2 The Employer shall not use such documents, data and other information received from the Contractor for any purpose other than the operation and maintenance of the Facilities. Similarly, the Contractor shall not use such documents, data and other information received from the Employer for any purpose other than the design, procurement of Plant and Equipment, construction or such other work and services as are required for the performance of the Contract.
- 16.3 The obligation of a party under GCC Sub-Clauses 16.1 and 16.2 above, however, shall not apply to that information which
- (a) now or hereafter enters the public domain through no fault of that party
 - (b) can be proven to have been possessed by that party at the time of disclosure and which was not previously obtained, directly or indirectly, from the other party hereto

(c) Otherwise lawfully becomes available to that party from a third party that has no obligation of confidentiality.

16.4 The above provisions of this GCC Clause 16 shall not in any way modify any undertaking of confidentiality given by either of the parties hereto prior to the date of the Contract in respect of the Facilities or any part thereof.

16.5 The provisions of this GCC Clause 16 shall survive termination, for whatever reason, of the Contract.

E. Execution of the Facilities

17. Representatives 17.1 Project Manager

If the Project Manager is not named in the Contract, then within fourteen (14) days of the Effective Date, the Employer shall appoint and notify the Contractor in writing of the name of the Project Manager. The Employer may from time to time appoint some other person as the Project Manager in place of the person previously so appointed, and shall give a notice of the name of such other person to the Contractor without delay. No such appointment shall be made at such a time or in such a manner as to impede the progress of work on the Facilities. Such appointment shall only take effect upon receipt of such notice by the Contractor. The Project Manager shall represent and act for the Employer at all times during the currency of the Contract. All notices, instructions, orders, certificates, approvals and all other communications under the Contract shall be given by the Project Manager, except as herein otherwise provided.

All notices, instructions, information and other communications given by the Contractor to the Employer under the Contract shall be given to the Project Manager, except as herein otherwise provided.

17.2 Contractor's Representative & Construction Manager

17.2.1 If the Contractor's Representative is not named in the Contract, then within fourteen (14) days of the Effective Date, the Contractor shall appoint the Contractor's Representative and shall request the Employer in writing to approve the person so appointed. If the Employer makes no objection to the appointment within fourteen (14) days, the Contractor's Representative shall be deemed

to have been approved. If the Employer objects to the appointment within fourteen (14) days giving the reason therefor, then the Contractor shall appoint a replacement within fourteen (14) days of such objection, and the foregoing provisions of this GCC Sub-Clause 17.2.1 shall apply thereto.

17.2.2 The Contractor's Representative shall represent and act for the Contractor at all times during the currency of the Contract and shall give to the Project Manager all the Contractor's notices, instructions, information and all other communications under the Contract.

All notices, instructions, information and all other communications given by the Employer or the Project Manager to the Contractor under the Contract shall be given to the Contractor's Representative or, in its absence, its deputy, except as herein otherwise provided.

The Contractor shall not revoke the appointment of the Contractor's Representative without the Employer's prior written consent, which shall not be unreasonably withheld. If the Employer consents thereto, the Contractor shall appoint some other person as the Contractor's Representative, pursuant to the procedure set out in GCC Sub-Clause 17.2.1.

17.2.3 The Contractor's Representative may, subject to the approval of the Employer (which shall not be unreasonably withheld), at any time delegate to any person any of the powers, functions and authorities vested in him or her. Any such delegation may be revoked at any time. Any such delegation or revocation shall be subject to a prior notice signed by the Contractor's Representative, and shall specify the powers, functions and authorities thereby delegated or revoked. No such delegation or revocation shall take effect unless and until a copy thereof has been delivered to the Employer and the Project Manager.

Any act or exercise by any person of powers, functions and authorities so delegated to him or her in accordance with this GCC Sub-Clause 17.2.3 shall be deemed to be an act or exercise by the Contractor's Representative.

17.2.4 From the commencement of installation of the Facilities at

the Site until Completion, the Contractor's Representative shall appoint a suitable person as the construction manager (hereinafter referred to as "the Construction Manager"). The Construction Manager shall supervise all work done at the Site by the Contractor and shall be present at the Site throughout normal working hours except when on leave, sick or absent for reasons connected with the proper performance of the Contract. Whenever the Construction Manager is absent from the Site, a suitable person shall be appointed to act as his or her deputy.

17.2.5 The Employer may by notice to the Contractor object to any representative or person employed by the Contractor in the execution of the Contract who, in the reasonable opinion of the Employer, may behave inappropriately, may be incompetent or negligent, or may commit a serious breach of the Site regulations provided under GCC Sub-Clause 22.3. The Employer shall provide evidence of the same, whereupon the Contractor shall remove such person from the Facilities.

17.2.6 If any representative or person employed by the Contractor is removed in accordance with GCC Sub-Clause 17.2.5, the Contractor shall, where required, promptly appoint a replacement.

18. Work Program 18.1 Contractor's Organization

The Contractor shall supply to the Employer and the Project Manager a chart showing the proposed organization to be established by the Contractor for carrying out work on the Facilities. The chart shall include the identities of the key personnel together with the curricula vitae of such key personnel to be employed within twenty-one (21) days of the Effective Date. The Contractor shall promptly inform the Employer and the Project Manager in writing of any revision or alteration of such an organization chart.

18.2 Program of Performance

Within twenty-eight (28) days after the date of signing the Contract Agreement, the Contractor shall prepare and submit to the Project Manager a detailed program of performance of the Contract, made in the form specified in the SCC and showing the sequence in which it proposes to design, manufacture, transport, assemble, install and precommission the Facilities, as well as the date by which the Contractor reasonably requires that the Employer shall have fulfilled its obligations under the Contract so as to enable the Contractor to execute the Contract in

accordance with the program and to achieve Completion, Commissioning and Acceptance of the Facilities in accordance with the Contract. The program so submitted by the Contractor shall accord with the Time Schedule included in the corresponding Appendix (Time Schedule) to the Contract Agreement and any other dates and periods specified in the Contract. The Contractor shall update and revise the program as and when appropriate or when required by the Project Manager, but without modification in the Times for Completion given in the SCC and any extension granted in accordance with GCC Clause 40, and shall submit all such revisions to the Project Manager.

18.3 Progress Report

The Contractor shall monitor progress of all the activities specified in the program referred to in GCC Sub-Clause 18.2 above, and supply a progress report to the Project Manager every month.

The progress report shall be in a form acceptable to the Project Manager and shall indicate: (a) percentage completion achieved compared with the planned percentage completion for each activity; and (b) where any activity is behind the program, giving comments and likely consequences and stating the corrective action being taken.

18.4 Progress of Performance

If at any time the Contractor's actual progress falls behind the program referred to in GCC Sub-Clause 18.2, or it becomes apparent that it will so fall behind, the Contractor shall, at the request of the Employer or the Project Manager, prepare and submit to the Project Manager a revised program, taking into account the prevailing circumstances, and shall notify the Project Manager of the steps being taken to expedite progress so as to attain Completion of the Facilities within the Time for Completion under GCC Sub-Clause 8.2, any extension thereof entitled under GCC Sub-Clause 40.1, or any extended period as may otherwise be agreed upon between the Employer and the Contractor.

18.5 Work Procedures

The Contract shall be executed in accordance with the Contract Documents and the procedures given in the section on Sample Forms and Procedures of the Contract Documents.

The Contractor may execute the Contract in accordance with its own standard project execution plans and procedures to the extent that they do not conflict with the provisions contained in the Contract.

19. Subcontracting 19.1 The corresponding Appendix (List of Approved Subcontractors) to the Contract Agreement specifies major items of supply or services and a list of approved Subcontractors against each item, including vendors. Insofar as no Subcontractors are listed against any such item, the Contractor shall prepare a list of Subcontractors for such item for inclusion in such list. The Contractor may from time to time propose any addition to or deletion from any such list. The Contractor shall submit any such list or any modification thereto to the Employer for its approval in sufficient time so as not to impede the progress of work on the Facilities. Such approval by the Employer for any of the Subcontractors shall not relieve the Contractor from any of its obligations, duties or responsibilities under the Contract.

19.2 The Contractor shall select and employ its Subcontractors for such major items from those listed in the lists referred to in GCC Sub-Clause 19.1.

19.3 For items or parts of the Facilities not specified in the corresponding Appendix (List of Approved Subcontractors) to the Contract Agreement, the Contractor may employ such Subcontractors as it may select, at its discretion.

**20. Design and
Engineering**

20.1 Specifications and Drawings

20.1.1 The Contractor shall execute the basic and detailed design and the engineering work in compliance with the provisions of the Contract, or where not so specified, in accordance with good engineering practice.

The Contractor shall be responsible for any discrepancies, errors or omissions in the specifications, drawings and other technical documents that it has prepared, whether such specifications, drawings and other documents have been approved by the Project Manager or not, provided that such discrepancies, errors or omissions are not because of inaccurate information furnished in writing to the Contractor by or on behalf of the Employer.

20.1.2 The Contractor shall be entitled to disclaim responsibility for any design, data, drawing, specification or other

document, or any modification thereof provided or designated by or on behalf of the Employer, by giving a notice of such disclaimer to the Project Manager.

20.2 Codes and Standards

Wherever references are made in the Contract to codes and standards in accordance with which the Contract shall be executed, the edition or the revised version of such codes and standards current at the date twenty-eight (28) days prior to date of bid submission shall apply unless otherwise specified. During Contract execution, any changes in such codes and standards shall be applied after approval by the Employer and shall be treated in accordance with GCC Clause 39.

20.3 Approval/Review of Technical Documents by Project Manager

20.3.1 The Contractor shall prepare (or cause its Subcontractors to prepare) and furnish to the Project Manager the documents listed in the corresponding Appendix (List of Documents for Approval or Review) to the Contract Agreement for its approval or review as specified and in accordance with the requirements of GCC Sub-Clause 18.2 (Program of Performance).

Any part of the Facilities covered by or related to the documents to be approved by the Project Manager shall be executed only after the Project Manager's approval thereof.

GCC Sub-Clauses 20.3.2 through 20.3.7 shall apply to those documents requiring the Project Manager's approval, but not to those furnished to the Project Manager for its review only.

20.3.2 Within fourteen (14) days after receipt by the Project Manager of any document requiring the Project Manager's approval in accordance with GCC Sub-Clause 20.3.1, the Project Manager shall either return one copy thereof to the Contractor with its approval endorsed thereon or shall notify the Contractor in writing of its disapproval thereof and the reasons therefor and the modifications that the Project Manager proposes.

If the Project Manager fails to take such action within the said fourteen (14) days, then the said document shall be deemed to have been approved by the Project Manager.

- 20.3.3 The Project Manager shall not disapprove any document, except on the grounds that the document does not comply with some specified provision of the Contract or that it is contrary to good engineering practice.
- 20.3.4 If the Project Manager disapproves the document, the Contractor shall modify the document and resubmit it for the Project Manager's approval in accordance with GCC Sub-Clause 20.3.2. If the Project Manager approves the document subject to modification(s), the Contractor shall make the required modification(s), whereupon the document shall be deemed to have been approved.
- 20.3.5 If any dispute or difference occurs between the Employer and the Contractor in connection with or arising out of the disapproval by the Project Manager of any document and/or any modification(s) thereto that cannot be settled between the parties within a reasonable period, then such dispute or difference may be referred to an Adjudicator for determination in accordance with GCC Sub-Clause 6.1 hereof. If such dispute or difference is referred to an Adjudicator, the Project Manager shall give instructions as to whether and if so, how, performance of the Contract is to proceed. The Contractor shall proceed with the Contract in accordance with the Project Manager's instructions, provided that if the Adjudicator upholds the Contractor's view on the dispute and if the Employer has not given notice under GCC Sub-Clause 6.1.2 hereof, then the Contractor shall be reimbursed by the Employer for any additional costs incurred by reason of such instructions and shall be relieved of such responsibility or liability in connection with the dispute and the execution of the instructions as the Adjudicator shall decide, and the Time for Completion shall be extended accordingly.
- 20.3.6 The Project Manager's approval, with or without modification of the document furnished by the Contractor, shall not relieve the Contractor of any responsibility or liability imposed upon it by any provisions of the Contract except to the extent that any subsequent failure results from modifications required by the Project Manager.
- 20.3.7 The Contractor shall not depart from any approved document unless the Contractor has first submitted to the Project Manager an amended document and obtained the Project Manager's approval thereof, pursuant to the

provisions of this GCC Sub-Clause 20.3.

If the Project Manager requests any change in any already approved document and/or in any document based thereon, the provisions of GCC Clause 39 shall apply to such request.

21. Procurement

21.1 Plant and Equipment

Subject to GCC Sub-Clause 14.2, the Contractor shall manufacture or procure and transport all the Plant and Equipment in an expeditious and orderly manner to the Site.

21.2 Employer-Supplied Plant, Equipment, and Materials

If the corresponding Appendix (Scope of Works and Supply by the Employer) to the Contract Agreement provides that the Employer shall furnish any specific items of machinery, equipment or materials to the Contractor, the following provisions shall apply:

21.2.1 The Employer shall, at its own risk and expense, transport each item to the place on or near the Site as agreed upon by the parties and make such item available to the Contractor at the time specified in the program furnished by the Contractor, pursuant to GCC Sub-Clause 18.2, unless otherwise mutually agreed.

21.2.2 Upon receipt of such item, the Contractor shall inspect the same visually and notify the Project Manager of any detected shortage, defect or default. The Employer shall immediately remedy any shortage, defect or default, or the Contractor shall, if practicable and possible, at the request of the Employer, remedy such shortage, defect or default at the Employer's cost and expense. After inspection, such item shall fall under the care, custody and control of the Contractor. The provision of this GCC Sub-Clause 21.2.2 shall apply to any item supplied to remedy any such shortage or default or to substitute for any defective item, or shall apply to defective items that have been repaired.

21.2.3 The foregoing responsibilities of the Contractor and its obligations of care, custody and control shall not relieve the Employer of liability for any undetected shortage, defect or default, nor place the Contractor under any liability for any such shortage, defect or default whether under GCC Clause 27 or under any other provision of Contract.

21.3 Transportation

21.3.1 The Contractor shall at its own risk and expense transport all the Plant and Equipment and the Contractor's Equipment to the Site by the mode of transport that the Contractor judges most suitable under all the circumstances.

21.3.2 Unless otherwise provided in the Contract, the Contractor shall be entitled to select any safe mode of transport operated by any person to carry the Plant and Equipment and the Contractor's Equipment.

21.3.3 Upon dispatch of each shipment of the Plant and Equipment and the Contractor's Equipment, the Contractor shall notify the Employer by telex, cable, facsimile or Electronic Data Interchange (EDI) of the description of the Plant and Equipment and of the Contractor's Equipment, the point and means of dispatch, and the estimated time and point of arrival in the country where the Site is located, if applicable, and at the Site. The Contractor shall furnish the Employer with relevant shipping documents to be agreed upon between the parties.

21.3.4 The Contractor shall be responsible for obtaining, if necessary, approvals from the authorities for transportation of the Plant and Equipment and the Contractor's Equipment to the Site. The Employer shall use its best endeavors in a timely and expeditious manner to assist the Contractor in obtaining such approvals, if requested by the Contractor. The Contractor shall indemnify and hold harmless the Employer from and against any claim for damage to roads, bridges or any other traffic facilities that may be caused by the transport of the Plant and Equipment and the Contractor's Equipment to the Site.

21.4 Customs Clearance

The Contractor shall, at its own expense, handle all imported Plant and Equipment and Contractor's Equipment at the point(s) of import and shall handle any formalities for customs clearance, subject to the Employer's obligations under GCC Sub-Clause 14.2, provided that if applicable laws or regulations require any application or act to be made by or in the name of the Employer, the Employer shall take all necessary steps to comply with such

laws or regulations. In the event of delays in customs clearance that are not the fault of the Contractor, the Contractor shall be entitled to an extension in the Time for Completion, pursuant to GCC Clause 40.

22. Installation

22.1 Setting Out/Supervision/Labor

22.1.1 *Bench Mark*: The Contractor shall be responsible for the true and proper setting-out of the Facilities in relation to bench marks, reference marks and lines provided to it in writing by or on behalf of the Employer.

If, at any time during the progress of installation of the Facilities, any error shall appear in the position, level or alignment of the Facilities, the Contractor shall forthwith notify the Project Manager of such error and, at its own expense, immediately rectify such error to the reasonable satisfaction of the Project Manager. If such error is based on incorrect data provided in writing by or on behalf of the Employer, the expense of rectifying the same shall be borne by the Employer.

22.1.2 *Contractor's Supervision*: The Contractor shall give or provide all necessary superintendence during the installation of the Facilities, and the Construction Manager or its deputy shall be constantly on the Site to provide full-time superintendence of the installation. The Contractor shall provide and employ only technical personnel who are skilled and experienced in their respective callings and supervisory staff who are competent to adequately supervise the work at hand.

22.1.3 *Labor*:

- (a) The Contractor shall provide and employ on the Site in the installation of the Facilities such skilled, semi-skilled and unskilled labor as is necessary for the proper and timely execution of the Contract. The Contractor is encouraged to use local labor that has the necessary skills.
- (b) Unless otherwise provided in the Contract, the Contractor shall be responsible for the recruitment, transportation, accommodation and catering of all labor, local or expatriate, required for the execution of the Contract and for all payments in connection therewith.

- (c) The Contractor shall be responsible for obtaining all necessary permit(s) and/or visa(s) from the appropriate authorities for the entry of all labor and personnel to be employed on the Site into the country where the Site is located.
- (d) The Contractor shall at its own expense provide the means of repatriation to all of its and its Subcontractor's personnel employed on the Contract at the Site to their various home countries. It shall also provide suitable temporary maintenance of all such persons from the cessation of their employment on the Contract to the date programmed for their departure. In the event that the Contractor defaults in providing such means of transportation and temporary maintenance, the Employer may provide the same to such personnel and recover the cost of doing so from the Contractor.
- (e) The Contractor shall at all times during the progress of the Contract use its best endeavors to prevent any unlawful, riotous or disorderly conduct or behavior by or amongst its employees and the labor of its Subcontractors.
- (f) The Contractor shall, in all dealings with its labor and the labor of its Subcontractors currently employed on or connected with the Contract, pay due regard to all recognized festivals, official holidays, religious or other customs and all local laws and regulations pertaining to the employment of labor.

22.2 Contractor's Equipment

22.2.1 All Contractor's Equipment brought by the Contractor onto the Site shall be deemed to be intended to be used exclusively for the execution of the Contract. The Contractor shall not remove the same from the Site without the Project Manager's consent that such Contractor's Equipment is no longer required for the execution of the Contract.

22.2.2 Unless otherwise specified in the Contract, upon completion of the Facilities, the Contractor shall remove from the Site all Equipment brought by the Contractor

onto the Site and any surplus materials remaining thereon.

22.2.3 The Employer will, if requested, use its best endeavors to assist the Contractor in obtaining any local, state or national government permission required by the Contractor for the export of the Contractor's Equipment imported by the Contractor for use in the execution of the Contract that is no longer required for the execution of the Contract.

22.3 Site Regulations and Safety

The Employer and the Contractor shall establish Site regulations setting out the rules to be observed in the execution of the Contract at the Site and shall comply therewith. The Contractor shall prepare and submit to the Employer, with a copy to the Project Manager, proposed Site regulations for the Employer's approval, which approval shall not be unreasonably withheld.

Such Site regulations shall include, but shall not be limited to, rules in respect of security, safety of the Facilities, gate control, sanitation, medical care, and fire prevention.

22.4 Opportunities for Other Contractors

22.4.1 The Contractor shall, upon written request from the Employer or the Project Manager, give all reasonable opportunities for carrying out the work to any other contractors employed by the Employer on or near the Site.

22.4.2 If the Contractor, upon written request from the Employer or the Project Manager, makes available to other contractors any roads or ways the maintenance for which the Contractor is responsible, permits the use by such other contractors of the Contractor's Equipment, or provides any other service of whatsoever nature for such other contractors, the Employer shall fully compensate the Contractor for any loss or damage caused or occasioned by such other contractors in respect of any such use or service, and shall pay to the Contractor reasonable remuneration for the use of such equipment or the provision of such services.

22.4.3 The Contractor shall also so arrange to perform its work as to minimize, to the extent possible, interference with the work of other contractors. The Project Manager shall determine the resolution of any difference or conflict that

may arise between the Contractor and other contractors and the workers of the Employer in regard to their work.

22.4.4 The Contractor shall notify the Project Manager promptly of any defects in the other contractors' work that come to its notice, and that could affect the Contractor's work. The Project Manager shall determine the corrective measures, if any, required to rectify the situation after inspection of the Facilities. Decisions made by the Project Manager shall be binding on the Contractor.

22.5 Emergency Work

If, by reason of an emergency arising in connection with and during the execution of the Contract, any protective or remedial work is necessary as a matter of urgency to prevent damage to the Facilities, the Contractor shall immediately carry out such work.

If the Contractor is unable or unwilling to do such work immediately, the Employer may do or cause such work to be done as the Employer may determine is necessary in order to prevent damage to the Facilities. In such event the Employer shall, as soon as practicable after the occurrence of any such emergency, notify the Contractor in writing of such emergency, the work done and the reasons therefor. If the work done or caused to be done by the Employer is work that the Contractor was liable to do at its own expense under the Contract, the reasonable costs incurred by the Employer in connection therewith shall be paid by the Contractor to the Employer. Otherwise, the cost of such remedial work shall be borne by the Employer.

22.6 Site Clearance

22.6.1 *Site Clearance in Course of Performance:* In the course of carrying out the Contract, the Contractor shall keep the Site reasonably free from all unnecessary obstruction, store or remove any surplus materials, clear away any wreckage, rubbish or temporary works from the Site, and remove any Contractor's Equipment no longer required for execution of the Contract.

22.6.2 *Clearance of Site after Completion:* After Completion of all parts of the Facilities, the Contractor shall clear away and remove all wreckage, rubbish and debris of any kind from the Site, and shall leave the Site and Facilities clean and safe.

22.7 Watching and Lighting

The Contractor shall provide and maintain at its own expense all lighting, fencing, and watching when and where necessary for the proper execution and the protection of the Facilities, or for the safety of the owners and occupiers of adjacent property and for the safety of the public.

22.8 Work at Night and on Holidays

22.8.1 Unless otherwise provided in the Contract, no work shall be carried out during the night and on public holidays of the country where the Site is located without prior written consent of the Employer, except where work is necessary or required to ensure safety of the Facilities or for the protection of life, or to prevent loss or damage to property, when the Contractor shall immediately advise the Project Manager, provided that provisions of this GCC Sub-Clause 22.8.1 shall not apply to any work which is customarily carried out by rotary or double-shifts.

22.8.2 Notwithstanding GCC Sub-Clauses 22.8.1 or 22.1.3, if and when the Contractor considers it necessary to carry out work at night or on public holidays so as to meet the Time for Completion and requests the Employer's consent thereto, the Employer shall not unreasonably withhold such consent.

23. Test and Inspection

23.1 The Contractor shall at its own expense carry out at the place of manufacture and/or on the Site all such tests and/or inspections of the Plant and Equipment and any part of the Facilities as are specified in the Contract.

23.2 The Employer and the Project Manager or their designated representatives shall be entitled to attend the aforesaid test and/or inspection, provided that the Employer shall bear all costs and expenses incurred in connection with such attendance including, but not limited to, all traveling and board and lodging expenses.

23.3 Whenever the Contractor is ready to carry out any such test and/or inspection, the Contractor shall give a reasonable advance notice of such test and/or inspection and of the place and time thereof to the Project Manager. The Contractor shall obtain from any relevant third party or manufacturer any necessary permission or consent to enable the Employer and the Project

Manager (or their designated representatives) to attend the test and/or inspection.

- 23.4 The Contractor shall provide the Project Manager with a certified report of the results of any such test and/or inspection.

If the Employer or Project Manager (or their designated representatives) fails to attend the test and/or inspection, or if it is agreed between the parties that such persons shall not do so, then the Contractor may proceed with the test and/or inspection in the absence of such persons, and may provide the Project Manager with a certified report of the results thereof.

- 23.5 The Project Manager may require the Contractor to carry out any test and/or inspection not required by the Contract, provided that the Contractor's reasonable costs and expenses incurred in the carrying out of such test and/or inspection shall be added to the Contract Price. Further, if such test and/or inspection impedes the progress of work on the Facilities and/or the Contractor's performance of its other obligations under the Contract, due allowance will be made in respect of the Time for Completion and the other obligations so affected.

- 23.6 If any Plant and Equipment or any part of the Facilities fails to pass any test and/or inspection, the Contractor shall either rectify or replace such Plant and Equipment or part of the Facilities and shall repeat the test and/or inspection upon giving a notice under GCC Sub-Clause 23.3.

- 23.7 If any dispute or difference of opinion shall arise between the parties in connection with or arising out of the test and/or inspection of the Plant and Equipment or part of the Facilities that cannot be settled between the parties within a reasonable period of time, it may be referred to an Adjudicator for determination in accordance with GCC Sub-Clause 6.1.

- 23.8 The Contractor shall afford the Employer and the Project Manager, at the Employer's expense, access at any reasonable time to any place where the Plant and Equipment are being manufactured or the Facilities are being installed, in order to inspect the progress and the manner of manufacture or installation, provided that the Project Manager shall give the Contractor a reasonable prior notice.

- 23.9 The Contractor agrees that neither the execution of a test and/or

inspection of Plant and Equipment or any part of the Facilities, nor the attendance by the Employer or the Project Manager, nor the issue of any test certificate pursuant to GCC Sub-Clause 23.4, shall release the Contractor from any other responsibilities under the Contract.

23.10 No part of the Facilities or foundations shall be covered up on the Site without the Contractor carrying out any test and/or inspection required under the Contract. The Contractor shall give a reasonable notice to the Project Manager whenever any such part of the Facilities or foundations are ready or about to be ready for test and/or inspection; such test and/or inspection and notice thereof shall be subject to the requirements of the Contract.

23.11 The Contractor shall uncover any part of the Facilities or foundations, or shall make openings in or through the same as the Project Manager may from time to time require at the Site, and shall reinstate and make good such part or parts.

If any parts of the Facilities or foundations have been covered up at the Site after compliance with the requirement of GCC Sub-Clause 23.10 and are found to be executed in accordance with the Contract, the expenses of uncovering, making openings in or through, reinstating, and making good the same shall be borne by the Employer, and the Time for Completion shall be reasonably adjusted to the extent that the Contractor has thereby been delayed or impeded in the performance of any of its obligations under the Contract.

24. Completion of the Facilities

24.1 As soon as the Facilities or any part thereof has, in the opinion of the Contractor, been completed operationally and structurally and put in a tight and clean condition as specified in the Technical Specifications, excluding minor items not materially affecting the operation or safety of the Facilities, the Contractor shall so notify the Employer in writing.

24.2 Within seven (7) days after receipt of the notice from the Contractor under GCC Sub-Clause 24.1, the Employer shall supply the operating and maintenance personnel specified in the corresponding Appendix (Scope of Works and Supply by the Employer) to the Contract Agreement for Precommissioning of the Facilities or any part thereof.

Pursuant to the corresponding Appendix (Scope of Works and

Supply by the Employer) to the Contract Agreement, the Employer shall also provide, within the said seven (7) day period, the raw materials, utilities, lubricants, chemicals, catalysts, facilities, services and other matters required for Precommissioning of the Facilities or any part thereof.

- 24.3 As soon as reasonably practicable after the operating and maintenance personnel have been supplied by the Employer and the raw materials, utilities, lubricants, chemicals, catalysts, facilities, services and other matters have been provided by the Employer in accordance with GCC Sub-Clause 24.2, the Contractor shall commence Precommissioning of the Facilities or the relevant part thereof in preparation for Commissioning.
- 24.4 As soon as all works in respect of Precommissioning are completed and, in the opinion of the Contractor, the Facilities or any part thereof is ready for Commissioning, the Contractor shall so notify the Project Manager in writing.
- 24.5 The Project Manager shall, within fourteen (14) days after receipt of the Contractor's notice under GCC Sub-Clause 24.4, either issue a Completion Certificate in the form specified in the Sample Forms and Procedures section in the bidding documents, stating that the Facilities or that part thereof have reached Completion as of the date of the Contractor's notice under GCC Sub-Clause 24.4, or notify the Contractor in writing of any defects and/or deficiencies.

If the Project Manager notifies the Contractor of any defects and/or deficiencies, the Contractor shall then correct such defects and/or deficiencies, and shall repeat the procedure described in GCC Sub-Clause 24.4.

If the Project Manager is satisfied that the Facilities or that part thereof have reached Completion, the Project Manager shall, within seven (7) days after receipt of the Contractor's repeated notice, issue a Completion Certificate stating that the Facilities or that part thereof have reached Completion as of the date of the Contractor's repeated notice.

If the Project Manager is not so satisfied, then it shall notify the Contractor in writing of any defects and/or deficiencies within seven (7) days after receipt of the Contractor's repeated notice, and the above procedure shall be repeated.

- 24.6 If the Project Manager fails to issue the Completion Certificate and fails to inform the Contractor of any defects and/or deficiencies within fourteen (14) days after receipt of the Contractor's notice under GCC Sub-Clause 24.4 or within seven (7) days after receipt of the Contractor's repeated notice under GCC Sub-Clause 24.5, or if the Employer makes use of the Facilities or part thereof, then the Facilities or that part thereof shall be deemed to have reached Completion as of the date of the Contractor's notice or repeated notice, or as of the Employer's use of the Facilities, as the case may be.
- 24.7 As soon as possible after Completion, the Contractor shall complete all outstanding minor items so that the Facilities are fully in accordance with the requirements of the Contract, failing which the Employer will undertake such completion and deduct the costs thereof from any monies owing to the Contractor.
- 24.8 Upon Completion, the Employer shall be responsible for the care and custody of the Facilities or the relevant part thereof, together with the risk of loss or damage thereto, and shall thereafter take over the Facilities or the relevant part thereof.

**25. Commissioning
and
Operational
Acceptance**

25.1 Commissioning

25.1.1 Commissioning of the Facilities or any part thereof shall be commenced by the Contractor immediately after issue of the Completion Certificate by the Project Manager, pursuant to GCC Sub-Clause 24.5, or immediately after issue of the deemed Completion, under GCC Sub-Clause 24.6.

25.1.2 The Employer shall supply the operating and maintenance personnel and all raw materials, utilities, lubricants, chemicals, catalysts, facilities, services and other matters required for Commissioning.

25.2 Guarantee Test

25.2.1 The Guarantee Test (and repeats thereof) shall be conducted by the Contractor during Commissioning of the Facilities or the relevant part thereof to ascertain whether the Facilities or the relevant part can attain the Functional Guarantees specified in the Technical Specifications. The Contractor's and Project Manager's advisory personnel shall attend the Guarantee Test, and shall advise and assist the Employer. The Employer shall promptly provide the Contractor with such information as the Contractor may

reasonably require in relation to the conduct and results of the Guarantee Test (and any repeats thereof).

25.2.2 If for reasons not attributable to the Contractor, the Guarantee Test of the Facilities or the relevant part thereof cannot be successfully completed within the period from the date of Completion specified in the SCC or any other period agreed upon by the Employer and the Contractor, the Contractor shall be deemed to have fulfilled its obligations with respect to the Functional Guarantees, and GCC Sub-Clauses 28.2 and 28.3 shall not apply.

25.3 Operational Acceptance

25.3.1 Subject to GCC Sub-Clause 25.4 below, Operational Acceptance shall occur in respect of the Facilities or any part thereof when

- (a) the Guarantee Test has been successfully completed and the Functional Guarantees are met; or
- (b) the Guarantee Test has not been successfully completed or has not been carried out for reasons not attributable to the Contractor within the period from the date of Completion specified in the SCC or any other agreed upon period as specified in GCC Sub-Clause 25.2.2 above; or
- (c) the Contractor has paid the liquidated damages specified in GCC Sub-Clause 28.3 hereof; and
- (d) any minor items mentioned in GCC Sub-Clause 24.7 hereof relevant to the Facilities or that part thereof have been completed.

25.3.2 At any time after any of the events set out in GCC Sub-Clause 25.3.1 have occurred, the Contractor may give a notice to the Project Manager requesting the issue of an Operational Acceptance Certificate in the form provided in the Bidding Documents or in another form acceptable to the Employer in respect of the Facilities or the part thereof specified in such notice as of the date of such notice.

25.3.3 The Project Manager shall, after consultation with the Employer, and within seven (7) days after receipt of the Contractor's notice, issue an Operational Acceptance

Certificate.

25.3.4 If within seven (7) days after receipt of the Contractor's notice, the Project Manager fails to issue the Operational Acceptance Certificate or fails to inform the Contractor in writing of the justifiable reasons why the Project Manager has not issued the Operational Acceptance Certificate, the Facilities or the relevant part thereof shall be deemed to have been accepted as of the date of the Contractor's said notice.

25.4 Partial Acceptance

25.4.1 If the Contract specifies that Completion and Commissioning shall be carried out in respect of parts of the Facilities, the provisions relating to Completion and Commissioning including the Guarantee Test shall apply to each such part of the Facilities individually, and the Operational Acceptance Certificate shall be issued accordingly for each such part of the Facilities.

25.4.2 If a part of the Facilities comprises facilities such as buildings, for which no Commissioning or Guarantee Test is required, then the Project Manager shall issue the Operational Acceptance Certificate for such facility when it attains Completion, provided that the Contractor shall thereafter complete any outstanding minor items that are listed in the Operational Acceptance Certificate.

F. Guarantees and Liabilities

26. Completion Time Guarantee

26.1 The Contractor guarantees that it shall attain Completion of the Facilities (or a part for which a separate time for completion is specified in the SCC) within the Time for Completion specified in the SCC pursuant to GCC Sub-Clause 8.2, or within such extended time to which the Contractor shall be entitled under GCC Clause 40 hereof.

26.2 If the Contractor fails to attain Completion of the Facilities or any part thereof within the Time for Completion or any extension thereof under GCC Clause 40, the Contractor shall pay to the Employer liquidated damages in the amount specified in the SCC as a percentage rate of the Contract Price, or the relevant part thereof. The aggregate amount of such liquidated damages shall in no event exceed the amount specified as "Maximum" in the

SCC. Once the “Maximum” is reached, the Employer may consider termination of the Contract, pursuant to GCC Sub-Clause 42.2.2.

Such payment shall completely satisfy the Contractor’s obligation to attain Completion of the Facilities or the relevant part thereof within the Time for Completion or any extension thereof under GCC Clause 40. The Contractor shall have no further liability whatsoever to the Employer in respect thereof.

However, the payment of liquidated damages shall not in any way relieve the Contractor from any of its obligations to complete the Facilities or from any other obligations and liabilities of the Contractor under the Contract.

Save for liquidated damages payable under this GCC Sub-Clause 26.2, the failure by the Contractor to attain any milestone or other act, matter or thing by any date specified in the corresponding Appendix (Time Schedule) to the Contract Agreement and/or other program of work prepared pursuant to GCC Sub-Clause 18.2 shall not render the Contractor liable for any loss or damage thereby suffered by the Employer.

26.3 If the Contractor attains Completion of the Facilities or any part thereof before the Time for Completion or any extension thereof under GCC Clause 40, the Employer shall pay to the Contractor a bonus in the amount specified in the SCC. The aggregate amount of such bonus shall in no event exceed the amount specified as “Maximum” in the SCC.

**27. Defect
Liability**

27.1 The Contractor warrants that the Facilities or any part thereof shall be free from defects in the design, engineering, materials and workmanship of the Plant and Equipment supplied and of the work executed.

27.2 The Defect Liability Period shall be twenty four (24) months from the date of Completion of the Facilities (or any part thereof) or eighteen (18) months from the date of Operational Acceptance of the Facilities (or any part thereof), whichever occurs later, unless specified otherwise in the SCC.

If during the Defect Liability Period any defect should be found in the design, engineering, materials and workmanship of the Plant and Equipment supplied or of the work executed by the Contractor, the Contractor shall promptly, in consultation and

agreement with the Employer regarding appropriate remedying of the defects, and at its cost, repair, replace or otherwise make good (as the Contractor shall, at its discretion, determine) such defect as well as any damage to the Facilities caused by such defect. The Contractor shall not be responsible for the repair, replacement or making good of any defect or of any damage to the Facilities arising out of or resulting from any of the following causes:

- (a) improper operation or maintenance of the Facilities by the Employer
- (b) operation of the Facilities outside specifications provided in the Contract
- (c) normal wear and tear.

27.3 The Contractor's obligations under this GCC Clause 27 shall not apply to

- (a) any materials that are supplied by the Employer under GCC Sub-Clause 21.2, are normally consumed in operation, or have a normal life shorter than the Defect Liability Period stated herein
- (b) any designs, specifications or other data designed, supplied or specified by or on behalf of the Employer or any matters for which the Contractor has disclaimed responsibility herein
- (c) any other materials supplied or any other work executed by or on behalf of the Employer, except for the work executed by the Employer under GCC Sub-Clause 27.7.

27.4 The Employer shall give the Contractor a notice stating the nature of any such defect together with all available evidence thereof, promptly following the discovery thereof. The Employer shall afford all reasonable opportunity for the Contractor to inspect any such defect.

27.5 The Employer shall afford the Contractor all necessary access to the Facilities and the Site to enable the Contractor to perform its obligations under this GCC Clause 27.

The Contractor may, with the consent of the Employer, remove from the Site any Plant and Equipment or any part of the Facilities that are defective if the nature of the defect, and/or any damage to the Facilities caused by the defect, is such that repairs cannot be expeditiously carried out at the Site.

- 27.6 If the repair, replacement or making good is of such a character that it may affect the efficiency of the Facilities or any part thereof, the Employer may give to the Contractor a notice requiring that tests of the defective part of the Facilities shall be made by the Contractor immediately upon completion of such remedial work, whereupon the Contractor shall carry out such tests.

If such part fails the tests, the Contractor shall carry out further repair, replacement or making good (as the case may be) until that part of the Facilities passes such tests. The tests shall be agreed upon by the Employer and the Contractor.

- 27.7 If the Contractor fails to commence the work necessary to remedy such defect or any damage to the Facilities caused by such defect within a reasonable time (which shall in no event be considered to be less than fifteen (15) days), the Employer may, following notice to the Contractor, proceed to do such work, and the reasonable costs incurred by the Employer in connection therewith shall be paid to the Employer by the Contractor or may be deducted by the Employer from any monies due the Contractor or claimed under the Performance Security.
- 27.8 If the Facilities or any part thereof cannot be used by reason of such defect and/or making good of such defect, the Defect Liability Period of the Facilities or such part, as the case may be, shall be extended by a period equal to the period during which the Facilities or such part cannot be used by the Employer because of any of the aforesaid reasons.
- 27.9 Except as provided in GCC Clauses 27 and 33, the Contractor shall be under no liability whatsoever and howsoever arising, and whether under the Contract or at law, in respect of defects in the Facilities or any part thereof, the Plant and Equipment, design or engineering or work executed that appear after Completion of the Facilities or any part thereof, except where such defects are the result of the gross negligence, fraud, criminal or willful action of the Contractor.
- 27.10 In addition, the Contractor shall also provide an extended

warranty for any such component of the Facilities and during the period of time as may be specified in the SCC. Such obligation shall be in addition to the defect liability specified under GCC Sub-Clause 27.2.

28. Functional Guarantees

28.1 The Contractor guarantees that during the Guarantee Test, the Facilities and all parts thereof shall attain the Functional Guarantees specified in the corresponding Appendix (Functional Guarantees) to the Contract Agreement, subject to and upon the conditions therein specified.

28.2 If, for reasons attributable to the Contractor, the minimum level of the Functional Guarantees specified in the corresponding Appendix (Functional Guarantees) to the Contract Agreement are not met either in whole or in part, the Contractor shall at its cost and expense make such changes, modifications and/or additions to the Plant or any part thereof as may be necessary to meet at least the minimum level of such Guarantees. The Contractor shall notify the Employer upon completion of the necessary changes, modifications and/or additions, and shall request the Employer to repeat the Guarantee Test until the minimum level of the Guarantees has been met. If the Contractor eventually fails to meet the minimum level of Functional Guarantees, the Employer may consider termination of the Contract, pursuant to GCC Sub-Clause 42.2.2.

28.3 If, for reasons attributable to the Contractor, the Functional Guarantees specified in the corresponding Appendix (Functional Guarantees) to the Contract Agreement are not attained either in whole or in part, but the minimum level of the Functional Guarantees specified in the said Appendix to the Contract Agreement is met, the Contractor shall, at the Contractor's option, either

(a) make such changes, modifications and/or additions to the Facilities or any part thereof that are necessary to attain the Functional Guarantees at its cost and expense, and shall request the Employer to repeat the Guarantee Test or

(b) pay liquidated damages to the Employer in respect of the failure to meet the Functional Guarantees in accordance with the provisions in the corresponding Appendix (Functional Guarantees) to the Contract Agreement.

28.4 The payment of liquidated damages under GCC Sub-Clause 28.3, up to the limitation of liability specified in the SCC, shall completely satisfy the Contractor's guarantees under GCC Sub-

Clause 28.3, and the Contractor shall have no further liability whatsoever to the Employer in respect thereof. Upon the payment of such liquidated damages by the Contractor, the Project Manager shall issue the Operational Acceptance Certificate for the Facilities or any part thereof in respect of which the liquidated damages have been so paid.

**29. Patent
Indemnity**

29.1 The Contractor shall, subject to the Employer's compliance with GCC Sub-Clause 29.2, indemnify and hold harmless the Employer and its employees and officers from and against any and all suits, actions or administrative proceedings, claims, demands, losses, damages, costs, and expenses of whatsoever nature, including attorney's fees and expenses, which the Employer may suffer as a result of any infringement or alleged infringement of any patent, utility model, registered design, trademark, copyright or other intellectual property right registered or otherwise existing at the date of the Contract by reason of: (a) the installation of the Facilities by the Contractor or the use of the Facilities in the country where the Site is located; and (b) the sale of the products produced by the Facilities in any country.

Such indemnity shall not cover any use of the Facilities or any part thereof other than for the purpose indicated by or to be reasonably inferred from the Contract, any infringement resulting from the use of the Facilities or any part thereof, or any products produced thereby in association or combination with any other equipment, plant or materials not supplied by the Contractor, pursuant to the Contract Agreement.

29.2 If any proceedings are brought or any claim is made against the Employer arising out of the matters referred to in GCC Sub-Clause 29.1, the Employer shall promptly give the Contractor a notice thereof, and the Contractor may at its own expense and in the Employer's name conduct such proceedings or claim and any negotiations for the settlement of any such proceedings or claim.

If the Contractor fails to notify the Employer within twenty-eight (28) days after receipt of such notice that it intends to conduct any such proceedings or claim, then the Employer shall be free to conduct the same on its own behalf. Unless the Contractor has so failed to notify the Employer within the twenty-eight (28) day period, the Employer shall make no admission that may be

prejudicial to the defense of any such proceedings or claim.

The Employer shall, at the Contractor's request, afford all available assistance to the Contractor in conducting such proceedings or claim, and shall be reimbursed by the Contractor for all reasonable expenses incurred in so doing.

29.3 The Employer shall indemnify and hold harmless the Contractor and its employees, officers and Subcontractors from and against any and all suits, actions or administrative proceedings, claims, demands, losses, damages, costs, and expenses of whatsoever nature, including attorney's fees and expenses, which the Contractor may suffer as a result of any infringement or alleged infringement of any patent, utility model, registered design, trademark, copyright or other intellectual property right registered or otherwise existing at the date of the Contract arising out of or in connection with any design, data, drawing, specification, or other documents or materials provided or designed by or on behalf of the Employer.

30. Limitation of Liability

30.1 Except in cases of criminal negligence or willful misconduct,

- (a) the Contractor shall not be liable to the Employer, whether in contract, tort, or otherwise, for any indirect or consequential loss or damage, loss of use, loss of production, or loss of profits or interest costs, provided that this exclusion shall not apply to any obligation of the Contractor to pay liquidated damages to the Employer and
- (b) the aggregate liability of the Contractor to the Employer, whether under the Contract, in tort or otherwise, shall not exceed the total Contract Price, provided that this limitation shall not apply to the cost of repairing or replacing defective equipment, or to any obligation of the Contractor to indemnify the Employer with respect to patent infringement.

G. Risk Distribution

31. Transfer of Ownership

31.1 Ownership of the Plant and Equipment (including spare parts) to be imported into the country where the Site is located shall be transferred to the Employer upon loading on to the mode of transport to be used to convey the Plant and Equipment from the country of origin to that country.

- 31.2 Ownership of the Plant and Equipment (including spare parts) procured in the country where the Site is located shall be transferred to the Employer when the Plant and Equipment are brought on to the Site.
- 31.3 Ownership of the Contractor's Equipment used by the Contractor and its Subcontractors in connection with the Contract shall remain with the Contractor or its Subcontractors.
- 31.4 Ownership of any Plant and Equipment in excess of the requirements for the Facilities shall revert to the Contractor upon Completion of the Facilities or at such earlier time when the Employer and the Contractor agree that the Plant and Equipment in question are no longer required for the Facilities.
- 31.5 Notwithstanding the transfer of ownership of the Plant and Equipment, the responsibility for care and custody thereof together with the risk of loss or damage thereto shall remain with the Contractor pursuant to GCC Clause 32 (Care of Facilities) hereof until Completion of the Facilities or the part thereof in which such Plant and Equipment are incorporated.

32. Care of Facilities

- 32.1 The Contractor shall be responsible for the care and custody of the Facilities or any part thereof until the date of Completion of the Facilities pursuant to GCC Clause 24 or, where the Contract provides for Completion of the Facilities in parts, until the date of Completion of the relevant part, and shall make good at its own cost any loss or damage that may occur to the Facilities or the relevant part thereof from any cause whatsoever during such period. The Contractor shall also be responsible for any loss or damage to the Facilities caused by the Contractor or its Subcontractors in the course of any work carried out, pursuant to GCC Clause 27. Notwithstanding the foregoing, the Contractor shall not be liable for any loss or damage to the Facilities or that part thereof caused by reason of any of the matters specified or referred to in paragraphs (a), (b) and (c) of GCC Sub-Clauses 32.2 and 38.1.
- 32.2 If any loss or damage occurs to the Facilities or any part thereof or to the Contractor's temporary facilities by reason of
- (a) (insofar as they relate to the country where the Site is located) nuclear reaction, nuclear radiation, radioactive contamination, pressure wave caused by aircraft or other aerial objects, or any other occurrences that an experienced contractor could not reasonably foresee, or if reasonably foreseeable could not reasonably make provision for or

insure against, insofar as such risks are not normally insurable on the insurance market and are mentioned in the general exclusions of the policy of insurance, including War Risks and Political Risks, taken out under GCC Clause 34 hereof

- (b) any use or occupation by the Employer or any third party (other than a Subcontractor) authorized by the Employer of any part of the Facilities
- (c) any use of or reliance upon any design, data or specification provided or designated by or on behalf of the Employer, or any such matter for which the Contractor has disclaimed responsibility herein,

the Employer shall pay to the Contractor all sums payable in respect of the Facilities executed, notwithstanding that the same be lost, destroyed or damaged, and will pay to the Contractor the replacement value of all temporary facilities and all parts thereof lost, destroyed or damaged. If the Employer requests the Contractor in writing to make good any loss or damage to the Facilities thereby occasioned, the Contractor shall make good the same at the cost of the Employer in accordance with GCC Clause 39. If the Employer does not request the Contractor in writing to make good any loss or damage to the Facilities thereby occasioned, the Employer shall either request a change in accordance with GCC Clause 39, excluding the performance of that part of the Facilities thereby lost, destroyed or damaged, or, where the loss or damage affects a substantial part of the Facilities, the Employer shall terminate the Contract pursuant to GCC Sub-Clause 42.1 hereof.

32.3 The Contractor shall be liable for any loss of or damage to any Contractor's Equipment, or any other property of the Contractor used or intended to be used for purposes of the Facilities, except (i) as mentioned in GCC Sub-Clause 32.2 (with respect to the Contractor's temporary facilities), and (ii) where such loss or damage arises by reason of any of the matters specified in GCC Sub-Clauses 32.2 (b) and (c) and 38.1.

32.4 With respect to any loss or damage caused to the Facilities or any part thereof or to the Contractor's Equipment by reason of any of the matters specified in GCC Sub-Clause 38.1, the provisions of GCC Sub-Clause 38.3 shall apply.

33. Loss of or

33.1 Subject to GCC Sub-Clause 33.3, the Contractor shall indemnify

**Damage to
Property;
Accident or
Injury to
Workers;
Indemnification**

and hold harmless the Employer and its employees and officers from and against any and all suits, actions or administrative proceedings, claims, demands, losses, damages, costs, and expenses of whatsoever nature, including attorney's fees and expenses, in respect of the death or injury of any person or loss of or damage to any property (other than the Facilities whether accepted or not), arising in connection with the supply and installation of the Facilities and by reason of the negligence of the Contractor or its Subcontractors, or their employees, officers or agents, except any injury, death or property damage caused by the negligence of the Employer, its contractors, employees, officers or agents.

- 33.2 If any proceedings are brought or any claim is made against the Employer that might subject the Contractor to liability under GCC Sub-Clause 33.1, the Employer shall promptly give the Contractor a notice thereof and the Contractor may at its own expense and in the Employer's name conduct such proceedings or claim and any negotiations for the settlement of any such proceedings or claim.

If the Contractor fails to notify the Employer within twenty-eight (28) days after receipt of such notice that it intends to conduct any such proceedings or claim, then the Employer shall be free to conduct the same on its own behalf. Unless the Contractor has so failed to notify the Employer within the twenty-eight (28) day period, the Employer shall make no admission that may be prejudicial to the defense of any such proceedings or claim.

The Employer shall, at the Contractor's request, afford all available assistance to the Contractor in conducting such proceedings or claim, and shall be reimbursed by the Contractor for all reasonable expenses incurred in so doing.

- 33.3 The Employer shall indemnify and hold harmless the Contractor and its employees, officers and Subcontractors from any liability for loss of or damage to property of the Employer, other than the Facilities not yet taken over, that is caused by fire, explosion or any other perils, in excess of the amount recoverable from insurances procured under GCC Clause 34, provided that such fire, explosion or other perils were not caused by any act or failure of the Contractor.
- 33.4 The party entitled to the benefit of an indemnity under this GCC Clause 33 shall take all reasonable measures to mitigate any loss

or damage which has occurred. If the party fails to take such measures, the other party's liabilities shall be correspondingly reduced.

34. Insurance

34.1 To the extent specified in the corresponding Appendix (Insurance Requirements) to the Contract Agreement, the Contractor shall at its expense take out and maintain in effect, or cause to be taken out and maintained in effect, during the performance of the Contract, the insurances set forth below in the sums and with the deductibles and other conditions specified in the said Appendix. The identity of the insurers and the form of the policies shall be subject to the approval of the Employer, who should not unreasonably withhold such approval.

(a) Cargo Insurance During Transport

Covering loss or damage occurring while in transit from the Contractor's or Subcontractor's works or stores until arrival at the Site, to the Plant and Equipment (including spare parts therefor) and to the Contractor's Equipment.

(b) Installation All Risks Insurance

Covering physical loss or damage to the Facilities at the Site, occurring prior to Completion of the Facilities, with an extended maintenance coverage for the Contractor's liability in respect of any loss or damage occurring during the Defect Liability Period while the Contractor is on the Site for the purpose of performing its obligations during the Defect Liability Period.

(c) Third Party Liability Insurance

Covering bodily injury or death suffered by third parties (including the Employer's personnel) and loss of or damage to property occurring in connection with the supply and installation of the Facilities.

(d) Automobile Liability Insurance

Covering use of all vehicles used by the Contractor or its Subcontractors (whether or not owned by them) in connection with the execution of the Contract.

(e) Workers' Compensation

In accordance with the statutory requirements applicable in any country where the Contract or any part thereof is executed.

(f) Employer's Liability

In accordance with the statutory requirements applicable in any country where the Contract or any part thereof is executed.

(g) Other Insurances

Such other insurances as may be specifically agreed upon by the parties hereto as listed in the said the corresponding Appendix.

34.2 The Employer shall be named as co-insured under all insurance policies taken out by the Contractor pursuant to GCC Sub-Clause 34.1, except for the Third Party Liability, Workers' Compensation and Employer's Liability Insurances, and the Contractor's Subcontractors shall be named as co-insureds under all insurance policies taken out by the Contractor pursuant to GCC Sub-Clause 34.1 except for the Cargo Insurance During Transport, Workers' Compensation and Employer's Liability Insurances. All insurer's rights of subrogation against such co-insureds for losses or claims arising out of the performance of the Contract shall be waived under such policies.

34.3 The Contractor shall, in accordance with the provisions of the corresponding Appendix (Insurance Requirements) to the Contract Agreement, deliver to the Employer certificates of insurance (or copies of the insurance policies) as evidence that the required policies are in full force and effect. The certificates shall provide that no less than twenty-one (21) days' notice shall be given to the Employer by insurers prior to cancellation or material modification of a policy.

34.4 The Contractor shall ensure that, where applicable, its Subcontractor(s) shall take out and maintain in effect adequate insurance policies for their personnel and vehicles and for work executed by them under the Contract, unless such Subcontractors are covered by the policies taken out by the Contractor.

34.5 The Employer shall at its expense take out and maintain in effect during the performance of the Contract those insurances specified in the corresponding Appendix (Insurance Requirements) to the Contract Agreement, in the sums and with the deductibles and other conditions specified in the said Appendix. The Contractor and the Contractor's Subcontractors shall be named as co-insureds under all such policies. All

insurers' rights of subrogation against such co-insureds for losses or claims arising out of the performance of the Contract shall be waived under such policies. The Employer shall deliver to the Contractor satisfactory evidence that the required insurances are in full force and effect. The policies shall provide that not less than twenty-one (21) days' notice shall be given to the Contractor by all insurers prior to any cancellation or material modification of the policies. If so requested by the Contractor, the Employer shall provide copies of the policies taken out by the Employer under this GCC Sub-Clause 34.5.

34.6 If the Contractor fails to take out and/or maintain in effect the insurances referred to in GCC Sub-Clause 34.1, the Employer may take out and maintain in effect any such insurances and may from time to time deduct from any amount due the Contractor under the Contract any premium that the Employer shall have paid to the insurer, or may otherwise recover such amount as a debt due from the Contractor. If the Employer fails to take out and/or maintain in effect the insurances referred to in GCC 34.5, the Contractor may take out and maintain in effect any such insurances and may from time to time deduct from any amount due the Employer under the Contract any premium that the Contractor shall have paid to the insurer, or may otherwise recover such amount as a debt due from the Employer. If the Contractor fails to or is unable to take out and maintain in effect any such insurances, the Contractor shall nevertheless have no liability or responsibility towards the Employer, and the Contractor shall have full recourse against the Employer for any and all liabilities of the Employer herein.

34.7 Unless otherwise provided in the Contract, the Contractor shall prepare and conduct all and any claims made under the policies effected by it pursuant to this GCC Clause 34, and all monies payable by any insurers shall be paid to the Contractor. The Employer shall give to the Contractor all such reasonable assistance as may be required by the Contractor. With respect to insurance claims in which the Employer's interest is involved, the Contractor shall not give any release or make any compromise with the insurer without the prior written consent of the Employer. With respect to insurance claims in which the Contractor's interest is involved, the Employer shall not give any release or make any compromise with the insurer without the prior written consent of the Contractor.

35. Unforeseen

35.1 If, during the execution of the Contract, the Contractor shall

Conditions

encounter on the Site any physical conditions (other than climatic conditions) or artificial obstructions that could not have been reasonably foreseen prior to the date of the Contract Agreement by an experienced contractor on the basis of reasonable examination of the data relating to the Facilities (including any data as to boring tests) provided by the Employer, and on the basis of information that it could have obtained from a visual inspection of the Site (if access thereto was available) or other data readily available to it relating to the Facilities, and if the Contractor determines that it will in consequence of such conditions or obstructions incur additional cost and expense or require additional time to perform its obligations under the Contract that would not have been required if such physical conditions or artificial obstructions had not been encountered, the Contractor shall promptly, and before performing additional work or using additional Plant and Equipment or Contractor's Equipment, notify the Project Manager in writing of

- (a) the physical conditions or artificial obstructions on the Site that could not have been reasonably foreseen
- (b) the additional work and/or Plant and Equipment and/or Contractor's Equipment required, including the steps which the Contractor will or proposes to take to overcome such conditions or obstructions
- (c) the extent of the anticipated delay
- (d) the additional cost and expense that the Contractor is likely to incur.

On receiving any notice from the Contractor under this GCC Sub-Clause 35.1, the Project Manager shall promptly consult with the Employer and Contractor and decide upon the actions to be taken to overcome the physical conditions or artificial obstructions encountered. Following such consultations, the Project Manager shall instruct the Contractor, with a copy to the Employer, of the actions to be taken.

- 35.2 Any reasonable additional cost and expense incurred by the Contractor in following the instructions from the Project Manager to overcome such physical conditions or artificial obstructions referred to in GCC Sub-Clause 35.1 shall be paid by the Employer to the Contractor as an addition to the Contract Price.

35.3 If the Contractor is delayed or impeded in the performance of the Contract because of any such physical conditions or artificial obstructions referred to in GCC Sub-Clause 35.1, the Time for Completion shall be extended in accordance with GCC Clause 40.

36. Change in Laws and Regulations

36.1 If, after the date twenty-eight (28) days prior to the date of Bid submission, in the country where the Site is located, any law, regulation, ordinance, order or by-law having the force of law is enacted, promulgated, abrogated or changed (which shall be deemed to include any change in interpretation or application by the competent authorities) that subsequently affects the costs and expenses of the Contractor and/or the Time for Completion, the Contract Price shall be correspondingly increased or decreased, and/or the Time for Completion shall be reasonably adjusted to the extent that the Contractor has thereby been affected in the performance of any of its obligations under the Contract. Notwithstanding the foregoing, such additional or reduced costs shall not be separately paid or credited if the same has already been accounted for in the price adjustment provisions where applicable, in accordance with the SCC.

37. Force Majeure

37.1 “Force Majeure” shall mean any event beyond the reasonable control of the Employer or of the Contractor, as the case may be, and which is unavoidable notwithstanding the reasonable care of the party affected, and shall include, without limitation, the following:

- (a) war, hostilities or warlike operations (whether a state of war be declared or not), invasion, act of foreign enemy and civil war
- (b) rebellion, revolution, insurrection, mutiny, usurpation of civil or military government, conspiracy, riot, civil commotion and terrorist acts
- (c) confiscation, nationalization, mobilization, commandeering or requisition by or under the order of any government or de jure or de facto authority or ruler or any other act or failure to act of any local state or national government authority
- (d) strike, sabotage, lockout, embargo, import restriction, port congestion, lack of usual means of public transportation

and communication, industrial dispute, shipwreck, shortage or restriction of power supply, epidemics, quarantine and plague

- (e) earthquake, landslide, volcanic activity, fire, flood or inundation, tidal wave, typhoon or cyclone, hurricane, storm, lightning, or other inclement weather condition, nuclear and pressure waves or other natural or physical disaster
- (f) shortage of labor, materials or utilities where caused by circumstances that are themselves Force Majeure.

37.2 If either party is prevented, hindered or delayed from or in performing any of its obligations under the Contract by an event of Force Majeure, then it shall notify the other in writing of the occurrence of such event and the circumstances thereof within fourteen (14) days after the occurrence of such event.

37.3 The party who has given such notice shall be excused from the performance or punctual performance of its obligations under the Contract for so long as the relevant event of Force Majeure continues and to the extent that such party's performance is prevented, hindered or delayed. The Time for Completion shall be extended in accordance with GCC Clause 40.

37.4 The party or parties affected by the event of Force Majeure shall use reasonable efforts to mitigate the effect thereof upon its or their performance of the Contract and to fulfill its or their obligations under the Contract, but without prejudice to either party's right to terminate the Contract under GCC Sub-Clauses 37.6 and 38.5.

37.5 No delay or nonperformance by either party hereto caused by the occurrence of any event of Force Majeure shall

- (a) constitute a default or breach of the Contract
- (b) (subject to GCC Sub-Clauses 32.2, 38.3 and 38.4) give rise to any claim for damages or additional cost or expense occasioned thereby

if and to the extent that such delay or nonperformance is caused by the occurrence of an event of Force Majeure.

37.6 If the performance of the Contract is substantially prevented, hindered or delayed for a single period of more than sixty (60) days or an aggregate period of more than one hundred and twenty (120) days on account of one or more events of Force Majeure during the currency of the Contract, the parties will attempt to develop a mutually satisfactory solution, failing which either party may terminate the Contract by giving a notice to the other, but without prejudice to either party's right to terminate the Contract under GCC Sub-Clause 38.5.

37.7 In the event of termination pursuant to GCC Sub-Clause 37.6, the rights and obligations of the Employer and the Contractor shall be as specified in GCC Sub-Clauses 42.1.2 and 42.1.3.

37.8 Notwithstanding GCC Sub-Clause 37.5, Force Majeure shall not apply to any obligation of the Employer to make payments to the Contractor herein.

38. War Risks

38.1 "War Risks" shall mean any event specified in paragraphs (a) and (b) of GCC Sub-Clause 37.1 and any explosion or impact of any mine, bomb, shell, grenade or other projectile, missile, munitions or explosive of war, occurring or existing in or near the country (or countries) where the Site is located.

38.2 Notwithstanding anything contained in the Contract, the Contractor shall have no liability whatsoever for or with respect to

- (a) destruction of or damage to Facilities, Plant and Equipment, or any part thereof
- (b) destruction of or damage to property of the Employer or any third party
- (c) injury or loss of life

if such destruction, damage, injury or loss of life is caused by any War Risks, and the Employer shall indemnify and hold the Contractor harmless from and against any and all claims, liabilities, actions, lawsuits, damages, costs, charges or expenses arising in consequence of or in connection with the same.

38.3 If the Facilities or any Plant and Equipment or Contractor's Equipment or any other property of the Contractor used or intended to be used for the purposes of the Facilities shall sustain

destruction or damage by reason of any War Risks, the Employer shall pay the Contractor for

- (a) any part of the Facilities or the Plant and Equipment so destroyed or damaged (to the extent not already paid for by the Employer)
- (b) replacing or making good any Contractor's Equipment or other property of the Contractor so destroyed or damaged
- (c) replacing or making good any such destruction or damage to the Facilities or the Plant and Equipment or any part thereof

so far as may be required by the Employer, and as may be necessary for completion of the Facilities.

If the Employer does not require the Contractor to replace or make good any such destruction or damage to the Facilities, the Employer shall either request a change in accordance with GCC Clause 39, excluding the performance of that part of the Facilities thereby destroyed or damaged or, where the loss, destruction or damage affects a substantial part of the Facilities, shall terminate the Contract, pursuant to GCC Sub-Clause 42.1.

38.4 Notwithstanding anything contained in the Contract, the Employer shall pay the Contractor for any increased costs or incidentals to the execution of the Contract that are in any way attributable to, consequent on, resulting from, or in any way connected with any War Risks, provided that the Contractor shall as soon as practicable notify the Employer in writing of any such increased cost.

38.5 If during the performance of the Contract any War Risks shall occur that financially or otherwise materially affect the execution of the Contract by the Contractor, the Contractor shall use its reasonable efforts to execute the Contract with due and proper consideration given to the safety of its and its Subcontractors' personnel engaged in the work on the Facilities, provided, however, that if the execution of the work on the Facilities becomes impossible or is substantially prevented for a single period of more than sixty (60) days or an aggregate period of more than one hundred and twenty (120) days on account of any War Risks, the parties will attempt to develop a mutually satisfactory solution, failing which either party may terminate the Contract by giving a notice to the other.

38.6 In the event of termination pursuant to GCC Sub-Clauses 38.3 or 38.5, the rights and obligations of the Employer and the Contractor shall be specified in GCC Sub-Clauses 42.1.2 and 42.1.3.

H. Change in Contract Elements

39. Change in the Facilities

39.1 Introducing a Change

39.1.1 Subject to GCC Sub-Clauses 39.2.5 and 39.2.7, the Employer shall have the right to propose, and subsequently require, that the Project Manager order the Contractor from time to time during the performance of the Contract to make any change, modification, addition or deletion to, in or from the Facilities (hereinafter called “Change”), provided that such Change falls within the general scope of the Facilities and does not constitute unrelated work and that it is technically practicable, taking into account both the state of advancement of the Facilities and the technical compatibility of the Change envisaged with the nature of the Facilities as specified in the Contract.

39.1.2 The Contractor may from time to time during its performance of the Contract propose to the Employer (with a copy to the Project Manager) any Change that the Contractor considers necessary or desirable to improve the quality, efficiency or safety of the Facilities. The Employer may at its discretion approve or reject any Change proposed by the Contractor, provided that the Employer shall approve any Change proposed by the Contractor to ensure the safety of the Facilities.

39.1.3 Notwithstanding GCC Sub-Clauses 39.1.1 and 39.1.2, no change made necessary because of any default of the Contractor in the performance of its obligations under the Contract shall be deemed to be a Change, and such change shall not result in any adjustment of the Contract Price or the Time for Completion.

39.1.4 The procedure on how to proceed with and execute Changes is specified in GCC Sub-Clauses 39.2 and 39.3, and further details and sample forms are provided in the Sample Forms and Procedures section in the bidding documents.

39.2 Changes Originating from Employer

39.2.1 If the Employer proposes a Change pursuant to GCC Sub-Clause 39.1.1, it shall send to the Contractor a “Request for Change Proposal,” requiring the Contractor to prepare and furnish to the Project Manager as soon as reasonably

practicable a "Change Proposal," which shall include the following:

- (a) brief description of the Change
- (b) effect on the Time for Completion
- (c) estimated cost of the Change
- (d) effect on Functional Guarantees (if any)
- (e) effect on any other provisions of the Contract.

39.2.2 Prior to preparing and submitting the "Change Proposal," the Contractor shall submit to the Project Manager an "Estimate for Change Proposal," which shall be an estimate of the cost of preparing and submitting the Change Proposal.

Upon receipt of the Contractor's Estimate for Change Proposal, the Employer shall do one of the following:

- (a) accept the Contractor's estimate with instructions to the Contractor to proceed with the preparation of the Change Proposal
- (b) advise the Contractor of any part of its Estimate for Change Proposal that is unacceptable and request the Contractor to review its estimate
- (c) advise the Contractor that the Employer does not intend to proceed with the Change.

39.2.3 Upon receipt of the Employer's instruction to proceed under GCC Sub-Clause 39.2.2 (a), the Contractor shall, with proper expedition, proceed with the preparation of the Change Proposal, in accordance with GCC Sub-Clause 39.2.1.

39.2.4 The pricing of any Change shall, as far as practicable, be calculated in accordance with the rates and prices included in the Contract. If such rates and prices are inequitable, the parties thereto shall agree on specific rates for the valuation of the Change.

39.2.5 If before or during the preparation of the Change Proposal it becomes apparent that the aggregate effect of compliance therewith and with all other Change Orders that have already become binding upon the Contractor

under this GCC Clause 39 would be to increase or decrease the Contract Price as originally set forth in Article 2 (Contract Price) of the Contract Agreement by more than fifteen percent (15%), the Contractor may give a written notice of objection thereto prior to furnishing the Change Proposal as aforesaid. If the Employer accepts the Contractor's objection, the Employer shall withdraw the proposed Change and shall notify the Contractor in writing thereof.

The Contractor's failure to so object shall neither affect its right to object to any subsequent requested Changes or Change Orders herein, nor affect its right to take into account, when making such subsequent objection, the percentage increase or decrease in the Contract Price that any Change not objected to by the Contractor represents.

39.2.6 Upon receipt of the Change Proposal, the Employer and the Contractor shall mutually agree upon all matters therein contained. Within fourteen (14) days after such agreement, the Employer shall, if it intends to proceed with the Change, issue the Contractor with a Change Order.

If the Employer is unable to reach a decision within fourteen (14) days, it shall notify the Contractor with details of when the Contractor can expect a decision.

If the Employer decides not to proceed with the Change for whatever reason, it shall, within the said period of fourteen (14) days, notify the Contractor accordingly. Under such circumstances, the Contractor shall be entitled to reimbursement of all costs reasonably incurred by it in the preparation of the Change Proposal, provided that these do not exceed the amount given by the Contractor in its Estimate for Change Proposal submitted in accordance with GCC Sub-Clause 39.2.2.

39.2.7 If the Employer and the Contractor cannot reach agreement on the price for the Change, an equitable adjustment to the Time for Completion, or any other matters identified in the Change Proposal, the Employer may nevertheless instruct the Contractor to proceed with the Change by issue of a "Pending Agreement Change Order."

Upon receipt of a Pending Agreement Change Order, the Contractor shall immediately proceed with effecting the Changes covered by such Order. The parties shall thereafter attempt to reach agreement on the outstanding issues under the Change Proposal.

If the parties cannot reach agreement within sixty (60) days from the date of issue of the Pending Agreement Change Order, then the matter may be referred to the Adjudicator in accordance with the provisions of GCC Sub-Clause 6.1.

39.3 Changes Originating from Contractor

39.3.1 If the Contractor proposes a Change pursuant to GCC Sub-Clause 39.1.2, the Contractor shall submit to the Project Manager a written "Application for Change Proposal," giving reasons for the proposed Change and including the information specified in GCC Sub-Clause 39.2.1.

Upon receipt of the Application for Change Proposal, the parties shall follow the procedures outlined in GCC Sub-Clauses 39.2.6 and 39.2.7. However, should the Employer choose not to proceed, the Contractor shall not be entitled to recover the costs of preparing the Application for Change Proposal.

40. Extension of Time for Completion

40.1 The Time(s) for Completion specified in the SCC shall be extended if the Contractor is delayed or impeded in the performance of any of its obligations under the Contract by reason of any of the following:

- (a) any Change in the Facilities as provided in GCC Clause 39
- (b) any occurrence of Force Majeure as provided in GCC Clause 37, unforeseen conditions as provided in GCC Clause 35, or other occurrence of any of the matters specified or referred to in paragraphs (a), (b) and (c) of GCC Sub-Clause 32.2
- (c) any suspension order given by the Employer under GCC Clause 41 hereof or reduction in the rate of progress pursuant to GCC Sub-Clause 41.2 or
- (d) any changes in laws and regulations as provided in GCC Clause 36 or

- (e) any default or breach of the Contract by the Employer, specifically including failure to supply the items listed in the corresponding Appendix (Scope of Works and Supply by the Employer) to the Contract Agreement, or any activity, act or omission of any other contractors employed by the Employer or
- (f) any other matter specifically mentioned in the Contract

by such period as shall be fair and reasonable in all the circumstances and as shall fairly reflect the delay or impediment sustained by the Contractor.

40.2 Except where otherwise specifically provided in the Contract, the Contractor shall submit to the Project Manager a notice of a claim for an extension of the Time for Completion, together with particulars of the event or circumstance justifying such extension as soon as reasonably practicable after the commencement of such event or circumstance. As soon as reasonably practicable after receipt of such notice and supporting particulars of the claim, the Employer and the Contractor shall agree upon the period of such extension. In the event that the Contractor does not accept the Employer's estimate of a fair and reasonable time extension, the Contractor shall be entitled to refer the matter to an Adjudicator, pursuant to GCC Sub-Clause 6.1.

40.3 The Contractor shall at all times use its reasonable efforts to minimize any delay in the performance of its obligations under the Contract.

41. Suspension

41.1 The Employer may request the Project Manager, by notice to the Contractor, to order the Contractor to suspend performance of any or all of its obligations under the Contract. Such notice shall specify the obligation of which performance is to be suspended, the effective date of the suspension and the reasons therefor. The Contractor shall thereupon suspend performance of such obligation (except those obligations necessary for the care or preservation of the Facilities) until ordered in writing to resume such performance by the Project Manager.

If, by virtue of a suspension order given by the Project Manager, other than by reason of the Contractor's default or breach of the Contract, the Contractor's performance of any of its obligations is suspended for an aggregate period of more than ninety (90)

days, then at any time thereafter and provided that at that time such performance is still suspended, the Contractor may give a notice to the Project Manager requiring that the Employer shall, within twenty-eight (28) days of receipt of the notice, order the resumption of such performance or request and subsequently order a change in accordance with GCC Clause 39, excluding the performance of the suspended obligations from the Contract.

If the Employer fails to do so within such period, the Contractor may, by a further notice to the Project Manager, elect to treat the suspension, where it affects a part only of the Facilities, as a deletion of such part in accordance with GCC Clause 39 or, where it affects the whole of the Facilities, as termination of the Contract under GCC Sub-Clause 42.1.

41.2 If

- (a) the Employer has failed to pay the Contractor any sum due under the Contract within the specified period, has failed to approve any invoice or supporting documents without just cause pursuant to the corresponding Appendix (Terms and Procedures of Payment) to the Contract Agreement, or commits a substantial breach of the Contract, the Contractor may give a notice to the Employer that requires payment of such sum, with interest thereon as stipulated in GCC Sub-Clause 12.3, requires approval of such invoice or supporting documents, or specifies the breach and requires the Employer to remedy the same, as the case may be. If the Employer fails to pay such sum together with such interest, fails to approve such invoice or supporting documents or give its reasons for withholding such approval, or fails to remedy the breach or take steps to remedy the breach within fourteen (14) days after receipt of the Contractor's notice or
- (b) the Contractor is unable to carry out any of its obligations under the Contract for any reason attributable to the Employer, including but not limited to the Employer's failure to provide possession of or access to the Site or other areas in accordance with GCC Sub-Clause 10.2, or failure to obtain any governmental permit necessary for the execution and/or completion of the Facilities,

then the Contractor may by fourteen (14) days' notice to the Employer suspend performance of all or any of its obligations

under the Contract, or reduce the rate of progress.

41.3 If the Contractor's performance of its obligations is suspended or the rate of progress is reduced pursuant to this GCC Clause 41, then the Time for Completion shall be extended in accordance with GCC Sub-Clause 40.1, and any and all additional costs or expenses incurred by the Contractor as a result of such suspension or reduction shall be paid by the Employer to the Contractor in addition to the Contract Price, except in the case of suspension order or reduction in the rate of progress by reason of the Contractor's default or breach of the Contract.

41.4 During the period of suspension, the Contractor shall not remove from the Site any Plant and Equipment, any part of the Facilities or any Contractor's Equipment, without the prior written consent of the Employer.

42. Termination

42.1 Termination for Employer's Convenience

42.1.1 The Employer may at any time terminate the Contract for any reason by giving the Contractor a notice of termination that refers to this GCC Sub-Clause 42.1.

42.1.2 Upon receipt of the notice of termination under GCC Sub-Clause 42.1.1, the Contractor shall either immediately or upon the date specified in the notice of termination

- (a) cease all further work, except for such work as the Employer may specify in the notice of termination for the sole purpose of protecting that part of the Facilities already executed, or any work required to leave the Site in a clean and safe condition
- (b) terminate all subcontracts, except those to be assigned to the Employer pursuant to paragraph (d) (ii) below
- (c) remove all Contractor's Equipment from the Site, repatriate the Contractor's and its Subcontractors' personnel from the Site, remove from the Site any wreckage, rubbish and debris of any kind, and leave the whole of the Site in a clean and safe condition
- (d) In addition, the Contractor, subject to the payment specified in GCC Sub-Clause 42.1.3, shall

- (i) deliver to the Employer the parts of the Facilities executed by the Contractor up to the date of termination
- (ii) to the extent legally possible, assign to the Employer all right, title and benefit of the Contractor to the Facilities and to the Plant and Equipment as of the date of termination, and, as may be required by the Employer, in any subcontracts concluded between the Contractor and its Subcontractors
- (iii) deliver to the Employer all non-proprietary drawings, specifications and other documents prepared by the Contractor or its Subcontractors as at the date of termination in connection with the Facilities.

42.1.3 In the event of termination of the Contract under GCC Sub-Clause 42.1.1, the Employer shall pay to the Contractor the following amounts:

- (a) the Contract Price, properly attributable to the parts of the Facilities executed by the Contractor as of the date of termination
- (b) the costs reasonably incurred by the Contractor in the removal of the Contractor's Equipment from the Site and in the repatriation of the Contractor's and its Subcontractors' personnel
- (c) any amounts to be paid by the Contractor to its Subcontractors in connection with the termination of any subcontracts, including any cancellation charges
- (d) costs incurred by the Contractor in protecting the Facilities and leaving the Site in a clean and safe condition pursuant to paragraph (a) of GCC Sub-Clause 42.1.2
- (e) the cost of satisfying all other obligations, commitments and claims that the Contractor may in good faith have undertaken with third parties in connection with the Contract and that are not

covered by paragraphs (a) through (d) above.

42.2 Termination for Contractor's Default

42.2.1 The Employer, without prejudice to any other rights or remedies it may possess, may terminate the Contract forthwith in the following circumstances by giving a notice of termination and its reasons therefor to the Contractor, referring to this GCC Sub-Clause 42.2:

- (a) if the Contractor becomes bankrupt or insolvent, has a receiving order issued against it, compounds with its creditors, or, if the Contractor is a corporation, a resolution is passed or order is made for its winding up (other than a voluntary liquidation for the purposes of amalgamation or reconstruction), a receiver is appointed over any part of its undertaking or assets, or if the Contractor takes or suffers any other analogous action in consequence of debt
- (b) if the Contractor assigns or transfers the Contract or any right or interest therein in violation of the provision of GCC Clause 43.
- (c) if the Contractor, in the judgment of the Employer has engaged in corrupt or fraudulent practices in competing for or in executing the Contract.

For the purpose of this Sub-Clause:

“corrupt practice” means the offering, giving, receiving or soliciting of any thing of value to influence the action of a public official in the procurement process or in contract execution.

“fraudulent practice” means a misrepresentation of facts in order to influence a procurement process or the execution of a contract to the detriment of the Employer, and includes collusive practice among bidders (prior to or after bid submission) designed to establish bid prices at artificial non-competitive levels and to deprive the Employer of the benefits of free and open competition.

42.2.2 If the Contractor

- (a) has abandoned or repudiated the Contract
- (b) has without valid reason failed to commence work on the Facilities promptly or has suspended (other than pursuant to GCC Sub-Clause 41.2) the progress of Contract performance for more than twenty-eight (28) days after receiving a written instruction from the Employer to proceed
- (c) persistently fails to execute the Contract in accordance with the Contract or persistently neglects to carry out its obligations under the Contract without just cause
- (d) refuses or is unable to provide sufficient materials, services or labor to execute and complete the Facilities in the manner specified in the program furnished under GCC Sub-Clause 18.2 at rates of progress that give reasonable assurance to the Employer that the Contractor can attain Completion of the Facilities by the Time for Completion as extended, then the Employer may, without prejudice to any other rights it may possess under the Contract, give a notice to the Contractor stating the nature of the default and requiring the Contractor to remedy the same. If the Contractor fails to remedy or to take steps to remedy the same within fourteen (14) days of its receipt of such notice, then the Employer may terminate the Contract forthwith by giving a notice of termination to the Contractor that refers to this GCC Sub-Clause 42.2.

42.2.3 Upon receipt of the notice of termination under GCC Sub-Clauses 42.2.1 or 42.2.2, the Contractor shall, either immediately or upon such date as is specified in the notice of termination,

- (a) cease all further work, except for such work as the Employer may specify in the notice of termination for the sole purpose of protecting that part of the Facilities already executed, or any work required to leave the Site in a clean and safe condition
- (b) terminate all subcontracts, except those to be assigned to the Employer pursuant to paragraph (d) below

- (c) deliver to the Employer the parts of the Facilities executed by the Contractor up to the date of termination
- (d) to the extent legally possible, assign to the Employer all right, title and benefit of the Contractor to the Facilities and to the Plant and Equipment as of the date of termination, and, as may be required by the Employer, in any subcontracts concluded between the Contractor and its Subcontractors
- (e) deliver to the Employer all drawings, specifications and other documents prepared by the Contractor or its Subcontractors as of the date of termination in connection with the Facilities.

42.2.4 The Employer may enter upon the Site, expel the Contractor, and complete the Facilities itself or by employing any third party. The Employer may, to the exclusion of any right of the Contractor over the same, take over and use with the payment of a fair rental rate to the Contractor, with all the maintenance costs to the account of the Employer and with an indemnification by the Employer for all liability including damage or injury to persons arising out of the Employer's use of such equipment, any Contractor's Equipment owned by the Contractor and on the Site in connection with the Facilities for such reasonable period as the Employer considers expedient for the supply and installation of the Facilities.

Upon completion of the Facilities or at such earlier date as the Employer thinks appropriate, the Employer shall give notice to the Contractor that such Contractor's Equipment will be returned to the Contractor at or near the Site and shall return such Contractor's Equipment to the Contractor in accordance with such notice. The Contractor shall thereafter without delay and at its cost remove or arrange removal of the same from the Site.

42.2.5 Subject to GCC Sub-Clause 42.2.6, the Contractor shall be entitled to be paid the Contract Price attributable to the Facilities executed as of the date of termination, the value of any unused or partially used Plant and Equipment on the Site, and the costs, if any, incurred in protecting the

Facilities and in leaving the Site in a clean and safe condition pursuant to paragraph (a) of GCC Sub-Clause 42.2.3. Any sums due the Employer from the Contractor accruing prior to the date of termination shall be deducted from the amount to be paid to the Contractor under this Contract.

42.2.6 If the Employer completes the Facilities, the cost of completing the Facilities by the Employer shall be determined.

If the sum that the Contractor is entitled to be paid, pursuant to GCC Sub-Clause 42.2.5, plus the reasonable costs incurred by the Employer in completing the Facilities, exceeds the Contract Price, the Contractor shall be liable for such excess.

If such excess is greater than the sums due the Contractor under GCC Sub-Clause 42.2.5, the Contractor shall pay the balance to the Employer, and if such excess is less than the sums due the Contractor under GCC Sub-Clause 42.2.5, the Employer shall pay the balance to the Contractor.

The Employer and the Contractor shall agree, in writing, on the computation described above and the manner in which any sums shall be paid.

42.3 Termination by Contractor

42.3.1 If

- (a) the Employer has failed to pay the Contractor any sum due under the Contract within the specified period, has failed to approve any invoice or supporting documents without just cause pursuant to the corresponding Appendix (Terms and Procedures of Payment) of the Contract Agreement, or commits a substantial breach of the Contract, the Contractor may give a notice to the Employer that requires payment of such sum, with interest thereon as stipulated in GCC Sub-Clause 12.3, requires approval of such invoice or supporting documents, or specifies the breach and requires the Employer to remedy the same, as the case may be. If the Employer fails to pay such sum together with such

interest, fails to approve such invoice or supporting documents or give its reasons for withholding such approval, fails to remedy the breach or take steps to remedy the breach within fourteen (14) days after receipt of the Contractor's notice, or

- (b) the Contractor is unable to carry out any of its obligations under the Contract for any reason attributable to the Employer, including but not limited to the Employer's failure to provide possession of or access to the Site or other areas or failure to obtain any governmental permit necessary for the execution and/or completion of the Facilities,

then the Contractor may give a notice to the Employer thereof, and if the Employer has failed to pay the outstanding sum, to approve the invoice or supporting documents, to give its reasons for withholding such approval, or to remedy the breach within twenty-eight (28) days of such notice, or if the Contractor is still unable to carry out any of its obligations under the Contract for any reason attributable to the Employer within twenty-eight (28) days of the said notice, the Contractor may by a further notice to the Employer referring to this GCC Sub-Clause 42.3.1, forthwith terminate the Contract.

42.3.2 The Contractor may terminate the Contract forthwith by giving a notice to the Employer to that effect, referring to this GCC Sub-Clause 42.3.2, if the Employer becomes bankrupt or insolvent, has a receiving order issued against it, compounds with its creditors, or, being a corporation, if a resolution is passed or order is made for its winding up (other than a voluntary liquidation for the purposes of amalgamation or reconstruction), a receiver is appointed over any part of its undertaking or assets, or if the Employer takes or suffers any other analogous action in consequence of debt.

42.3.3 If the Contract is terminated under GCC Sub-Clauses 42.3.1 or 42.3.2, then the Contractor shall immediately

- (a) cease all further work, except for such work as may be necessary for the purpose of protecting that part of the Facilities already executed, or any work required

to leave the Site in a clean and safe condition

- (b) terminate all subcontracts, except those to be assigned to the Employer pursuant to paragraph (d)
 - (ii)
- (c) remove all Contractor's Equipment from the Site and repatriate the Contractor's and its Subcontractors' personnel from the Site.
- (d) In addition, the Contractor, subject to the payment specified in GCC Sub-Clause 42.3.4, shall
 - (i) deliver to the Employer the parts of the Facilities executed by the Contractor up to the date of termination
 - (ii) to the extent legally possible, assign to the Employer all right, title and benefit of the Contractor to the Facilities and to the Plant and Equipment as of the date of termination, and, as may be required by the Employer, in any subcontracts concluded between the Contractor and its Subcontractors
 - (iii) deliver to the Employer all drawings, specifications and other documents prepared by the Contractor or its Subcontractors as of the date of termination in connection with the Facilities.

42.3.4 If the Contract is terminated under GCC Sub-Clauses 42.3.1 or 42.3.2, the Employer shall pay to the Contractor all payments specified in GCC Sub-Clause 42.1.3, and reasonable compensation for all loss, except for loss of profit, or damage sustained by the Contractor arising out of, in connection with or in consequence of such termination.

42.3.5 Termination by the Contractor pursuant to this GCC Sub-Clause 42.3 is without prejudice to any other rights or remedies of the Contractor that may be exercised in lieu of or in addition to rights conferred by GCC Sub-Clause 42.3.

42.4 In this GCC Clause 42, the expression “Facilities executed” shall include all work executed, Installation Services provided, and all Plant and Equipment acquired (or subject to a legally binding obligation to purchase) by the Contractor and used or intended to be used for the purpose of the Facilities, up to and including the date of termination.

42.5 In this GCC Clause 42, in calculating any monies due from the Employer to the Contractor, account shall be taken of any sum previously paid by the Employer to the Contractor under the Contract, including any advance payment paid pursuant to the corresponding Appendix (Terms and Procedures of Payment) to the Contract Agreement.

43. Assignment

43.1 Neither the Employer nor the Contractor shall, without the express prior written consent of the other party (which consent shall not be unreasonably withheld), assign to any third party the Contract or any part thereof, or any right, benefit, obligation or interest therein or thereunder, except that the Contractor shall be entitled to assign either absolutely or by way of charge any monies due and payable to it or that may become due and payable to it under the Contract.

Section V. Special Conditions of Contract

Table of Clauses

| | |
|---|-----|
| 1. Definitions (GCC Clause 1)..... | 113 |
| 2. Notices (GCC Clause 4)..... | 113 |
| 3. Governing Law (GCC Clause 5)..... | 113 |
| 4. Settlement of Disputes (GCC Clause 6) | 113 |
| 5. Scope of Facilities /Spare Parts/ (GCC Clause 7)..... | 114 |
| 6. Time for Commencement and Completion (GCC Clause 8)..... | 114 |
| 7. Contract Price (GCC Clause 11)..... | 114 |
| 8. Securities (GCC Clause 13)..... | 115 |
| 9. Work Program (GCC Clause 18)..... | 115 |
| 10. Commissioning and Operational Acceptance (GCC Clause 25) | 115 |
| 11. Completion Time Guarantee (GCC Clause 26)..... | 115 |
| 12. Defect Liability (GCC Clause 27)..... | 115 |
| 13. Completion—Guarantee Test—Acceptance (GCC Clauses 24.3 and 25.2)..... | 115 |

Special Conditions of Contract

The following Special Conditions of Contract (SCC) shall supplement the General Conditions of Contract (GCC). Whenever there is a conflict, the provisions herein shall prevail over those in the GCC. The corresponding clause number of the GCC is indicated in parentheses.

1. Definitions (GCC Clause 1)

The Employer is: *Greater Visakhapatnam Smart City Corporation Limited (GVSSCL)*

The Project Manager is: *AECOM Asia Company Limited in JV with AECOM India Private Limited and Pricewatercoppers India Private Limited*

The Contractor is: *To be filled later after award of Contract*

The Contractor's Representative is: *To be filled later after award of Contract*

The Adjudicator is: *To be decided later*

Country of Origin: all countries and territories as indicated in the section of the bidding documents, Eligibility for the Provision of Goods, Works and Services in Employer-Financed Procurement.

Time for Completion: **6 Months**

2. Notices (GCC Clause 4)

GCC 4.1—Employer's address for notice purposes: *Managing Director, Greater Visakhapatnam Smart City Corporation Limited (GVSCCL), C/o Greater Visakhapatnam Municipal Corporation, Tenneti Bhavan, Ram Nagar, Visakhapatnam, 530003, India*

Telephone: +91 - 891 - 2746301-7

Facsimile number: +91-891-2568545

Contractor's address for notice purposes: *To be filled later*

3. Governing Law (GCC Clause 5)

GCC 5.1—The Contract shall be interpreted in accordance with the laws of the Employer's country.

4. Settlement of Disputes (GCC Clause 6)

GCC 6.1.3—Adjudicator's hourly fee: *To be decided later*

GCC 6.2.3 —Rules of procedure for arbitration proceedings: All disputes arising in connection with the present Contract shall be finally settled under the Rules of Arbitration and Reconciliation Act of 1996, in accordance with said Act.

(b) Contracts with contractors national of the Employer's country: Any dispute between the Employer and a Contractor who is a national of the Employer's country arising in connection with the present Contract shall be referred to adjudication or arbitration in accordance with the laws of the Employer's country.

5. Scope of Facilities /Spare Parts/ (GCC Clause 7)

GCC 7.3—The Contractor agrees to supply spare parts for a period of years: 5 year after defect liability period and one year of O&M period.

GCC 7.4—The Contractor shall carry sufficient inventories to ensure an ex-stock supply of consumable spares for the plant and equipment. Other spare parts and components shall be supplied as promptly as possible, but at the most within six (6) months of placing the order and opening the letter of credit. In addition, in the event of termination of the production of spare parts, advance notification will be made to the Employer of the pending termination, with sufficient time to permit the Employer to procure the needed requirement. Following such termination, the Contractor will furnish to the extent possible and at no cost to the Employer the blueprints, drawings and specifications of the spare parts, if requested.

6. Time for Commencement and Completion (GCC Clause 8)

GCC 8.1—The Contractor shall commence work on the Facilities from the Effective Date for determining Time for Completion as specified in the Contract Agreement.

GCC 8.2—The Completion of the Facilities shall be attained within 6 months from the effective date

7. Contract Price (GCC Clause 11)

GCC 11.2—The Contract Price shall be adjusted in accordance with the provisions of the corresponding Appendix (Price Adjustment) to the Contract Agreement – **No Contract Price Adjustment**

8. Payments (GCC Clause 12)

GCC 12.3 is deleted in totality.

9. Securities (GCC Clause 13)

GCC 13.3.1—The amount of performance security, as a percentage of the Contract Price for the Facility or for the part of the Facility for which a separate time for Completion is provided, shall be: **5%**

GCC 13.3.2—The performance security shall be in the form of the Bank Guarantee attached hereto in the section on Sample Forms and Procedures.

GCC 13.3.3—The performance security shall be reduced to ten percent (10%) of the value of the component covered by the extended warranty to cover the Contractor's extended warranty in accordance with the provision in the SCC, pursuant to GCC Sub-Clause 27.10.

10. Work Program (GCC Clause 18)

GCC 18.2—The form of the program of performance of the Contract shall be: CPM /PERT

11. Completion of Facilities (GCC Clause 24)

Operation and Maintenance period of 1 year is included in the Project.

12. Commissioning and Operational Acceptance (GCC Clause 25)

GCC 25.2.2—The Guarantee Test of the Facilities shall be successfully completed within 15 days from the date of Completion.

13. Completion Time Guarantee (GCC Clause 26)

GCC 26.2—Applicable rate for liquidated damages:

Maximum deduction for liquidated damages: *The applicable rate shall be half percent (0.5%) per week, and the maximum shall not exceed ten percent (10%) of the Contract Price.*

GCC 26.3— No bonus will be given for earlier Completion of the Facilities or part thereof.

14. Defect Liability (GCC Clause 27)

GCC 27.10—The critical components covered under the extended warranty are and the period shall be [5 (Five Year)].

13. Completion—Guarantee Test—Acceptance (GCC Clauses 24.3 and 25.2)

- 13.1 In the event that the Contractor is unable to proceed with the Precommissioning of the Facilities pursuant to Sub-Clause 24.3, or with the Guarantee Test pursuant to Sub-Clause 25.2, for reasons attributable to the Employer either on account of nonavailability of other facilities under the responsibilities of other contractor(s), or for reasons beyond the Employer's control, the provisions leading to "deemed" completion of activities such as Completion, pursuant to GCC Sub-Clause 24.6, and Operational Acceptance, pursuant to GCC Sub-Clause 25.3.4, and Contractor's obligations regarding Defect Liability Period, pursuant to GCC Sub-Clause 27.2, Functional Guarantee, pursuant to GCC Clause 28, and Care of Facilities, pursuant to GCC Clause 32, and GCC Clause 41.1, Suspension, shall not apply. In this case, the following provisions shall apply.
- 13.2 When the Contractor is notified by the Project Manager that he will be unable to proceed with the activities and obligations pursuant to above Sub-Clause 13.1, the Contractor shall be entitled to the following:
- (a) the Time of Completion shall be extended for the period of suspension without imposition of liquidated damages pursuant to GCC Sub-Clause 26.2;
 - (b) payments due to the Contractor in accordance with the provision specified in the corresponding Appendix (Terms and Procedures of Payment) to the Contract Agreement, which would not have been payable in normal circumstances due to non-completion of the subject activities, shall be released to the Contractor against submission of a security in the form of a bank guarantee of equivalent amount acceptable to the Employer, and which shall become null and void when the Contractor will have complied with its obligations regarding those payments, subject to the provision of Sub-Clause 13.3 below;
 - (c) the expenses towards the above security and extension of other securities under the contract, of which validity needs to be extended, shall be reimbursed to the Contractor by the Employer;
 - (d) the additional charges towards the care of the Facilities pursuant to GCC Sub-Clause 32.1 shall be reimbursed to the Contractor by the Employer for the period between the notification mentioned above and the notification mentioned in Sub-Clause 13.4 below. The provision of GCC Sub-Clause 33.2 shall apply to the Facilities during the same period.

- 13.3 In the event that the period of suspension under above Sub-Clause 13.1 actually exceeds one hundred eighty (180) days, the Employer and Contractor shall mutually agree to any additional compensation payable to the Contractor.
- 13.4 When the Contractor is notified by the Project Manager that the plant is ready for Precommissioning, the Contractor shall proceed without delay in performing all the specified activities and obligations under the contract.

Section VI. Technical Specifications and Drawings

1- GENERAL TECHNICAL SPECIFICATION FOR GRID TIED ROOF TOP SOLAR PV SYSTEMS

1.1 INTRODUCTION:

- 1.1.1 In grid-connected solar photo-voltaic (PV) systems, solar energy is fed into the building loads that are connected to the grid through a service connection with surplus energy being fed into the grid and shortfall being drawn from the grid. Production of surplus energy may happen when solar energy produced exceeds the energy consumption of the building. This surplus is fed into the grid. During the night, or when during the day energy demand in the building exceeds solar energy generation, energy is drawn from the grid. Grid-connected solar PV systems have no battery storage and will not work during grid outage. For buildings with grid-connected solar PV systems, the service connection meter needs to be of the bidirectional type, whereby import kWh and export kWh are separately recorded.
- 1.1.2 A grid-connected solar PV system consists of the solar panels, solar panels mounting structure, one or more solar grid inverters, protection devices, meters, interconnection cables and switches.
- 1.1.3 Components and parts used in solar PV systems should conform to the BIS or IEC or other international specifications, wherever such specifications are available and applicable.

1.2 QUALITY AND WORKMANSHIP:

Solar PV modules are designed to last 25 years or more. It is therefore essential that all system components and parts, including the mounting structures, cables, junction boxes, distribution boxes and other parts also have a life cycle of at least 25 years. Therefore, all works shall be undertaken with the highest levels of quality and workmanship. During inspection, special attention will be given to neatness of work execution and conformity with quality and safety norms. Non-compliant works will have to be redone at the cost of the Installer.

1.3 SYSTEM SIZING:

As per the solar net metering orders of the Punjab, crediting of energy for the purpose of net-metering is limited to 90% of the consumed energy during a 12 month settlement period. The maximum recommended solar PV capacity for grid-connected solar PV systems is therefore a capacity that produces not more than 90% of the annual energy consumption of the building.

1.4 SCOPE OF WORK:

- Site survey and Layout planning
- Design, development and supply of all components of the SPV power system
- Transportation of SPV Power system up to a project location
- Installation and commissioning of SPV Power system up to AC distribution board along with Net metering with necessary arrangement for integration grid and protection during absence of grid supply.
- Training of the staff
- Maintenance (CMC) during warranty period of 5 years

1.5 SCOPE OF SUPPLY:

The SPV power plants should be supplied & installed by the companies as per specifications given in Annexure –I which comply with the MNRE, GOI Guidelines. Following parts for each SPV projects are mainly required to be supplied:

- SPV Module of capacity ranging from 100Wp and above
- Power conditioning Unit (PCU) 1KW and above
- PVC insulated Copper cables as per BIS Codes for AC & DC inter connections.
- Junction Boxes with surge arrestors and MCB.
- Structure for solar PV project, MS Galvanized / Aluminum.
- O&M manual and warranty card in English Language
- 3.5c x185 sq mm 1100V PVC armoured aluminum cable as per IS 1554 (part-1) -30meter with system and if any more PVC cable required shall be supplied as per unit rate specified in price bid.
- Any other part as per site requirement.

The bidder has to provide/submit the following documents/details to GVSCCL for approval

- The detail of bill of materials,
- proposed equipment make with copies of relevant data sheets,
- IEC certificates of modules, inverters and other major equipment,
- Rooftop Module installation layout plan along with structure installation detail and structure load safety analysis by Chartered structure engineer along with electrical single line diagram of all project site (building)

1.6 WARRANTY:

- The Solar power projects including the battery shall be warranted for five years after the completion of defect liability period of the project for replacement in case of any manufacturing, operation failure, nonperformance as per design standards.
- The PV module(s) shall be warranted for a minimum period of 25 years from the date of commissioning of the project. The PV modules must be warranted for their output peak watt capacity, which should not be less than 90% at the end of Ten (10) years and 80% at the end of twenty-five (25) years.
- In the first 10 years, replacement warranty is to be given by the module manufacturer if it is established that higher degradation is due to manufacturing defects.
- The Warranty Card to be supplied with the system must contain the details of the system.
- In addition to maintenance during warranty period of 5 years after the completion of the 2 years defect liability period, after completion of 5 years' warranty period GVSCCL may go for additional 5 or 10 years O&M contract with the bidder. Bidder may provide separate quote for yearly comprehensive O&M charges for the above.

Maintenance during Warranty period of five years:

- a. Schedule visit of the supplier's engineer to the site on quarterly basis for maintenance/ assessing the maintenance requirements.
- b. Visit to the site on call basis to provide maintenance services within three days of lodging of complaint.

- c. Corrective & remedial maintenance services to set right the malfunction of the SPV-projects include supply and replacement of all damaged parts/ components including electronics/ charge controller, Inter connected cables/ parts and fuse etc. with new parts.

1.6.1 OPERATION & MAINTENANCE MANUAL:

An Operation, Instruction and Maintenance Manual, in English & Telgu Languages should be provided with the Solar PV projects. The following minimum details must be provided in the Manual:

- Basic principles of Photovoltaic.
- A small write-up (with a block diagram) on the Solar PV project - its components, PV module, battery, electronics and luminary and expected performance shall be provided.
- Type, Model number, Voltage & capacity of the battery, used in the system.
- The make, model number, country of origin and technical characteristics of the entire component are required to be provided.
- Clear instructions on regular maintenance and troubleshooting of the Solar PV Projects.
- DO's and DONT's.
- Name and address of the contact person for repair and maintenance, in case of non-functionality of the SPV Projects.

1.7- GENERAL TECHNICAL SPECIFICATIONS-

The General Technical Specifications must comply to the Govt of India regulations/standards and in addition to comply to with Net Metering Policy and Regulations of APSERC.

A. SPV MODULES :

- Indigenously manufactured PV modules should be used.
- The PV module should have crystalline silicon solar cells and must have a certificate of testing conforming to IEC 61215 Edition II / BIS 14286 from an NABL or IECQ accredited Laboratory.
- The power output of the module(s) under STC should be a minimum of 100 Wp at a load voltage* of 16.4 ± 0.2 V. Vnom 12V.
- The open circuit voltage* of the PV modules under STC should be at least 21.0 Volts.
- The module efficiency should not be less than 14 %.
- The terminal box on the module should have provision for opening to replace the cable, if required.
- PV modules must be warranted for their output peak watt capacity which should not be less than 90 % at the end of 10 years and 80% at the end of 25 years.

B. Identification and Traceability

Each PV module used in any solar power project must use a RF identification tag. The following information must be mentioned in the RFID used on each module (This should be inside the laminate and must be able to withstand harsh environmental conditions.)

- Name of the Manufacturer of PV module
- Name of the manufacturer of Solar Cells.
- Month and year of the manufacture (separately for solar cells and module).
- Country of origin (separately for solar cells and module).
- I-V curve for the module.
- Peak wattage, I_m , V_m and FF for the module.
- Unique serial no and model no of the module.
- Date and year of obtaining IEC PV module qualification certificate.
- Name of test lab issuing IEC certificate
- Other relevant information on traceability of solar cells and module as per ISO 9000 series.

C. BALANCE OF SYSTEM (BOS):

- Cables should confirm to applicable standards i.e. IEC 60189, IS 694/ IS1554, IS/IEC 69947.
- Switches / Circuit Breakers / Connector should confirm to IS/IEC 60947 part I,II,III,EN 50521 standards
- Junction Boxes should confirm to IP 65 for outdoor / IP 21 for indoor use and IEC 62208 standards.
- SPV system design should confirm to IEC 62124 standards
- Installation of systems should confirm to IEC 60364-7-712 standards

D. POWER CONDITIONING UNIT (PCU)

The PCU should convert DC power produced by SPV modules, in to AC power and adjust the voltage & frequency levels to suit the local grid conditions. The inverter shall interconnect and feed power to the LT power supply of the building and also shall have the provision to power critical loads.

Common Technical Specification:

| | |
|------------------------------|---|
| Control Type | : Voltage source, microprocessor assisted, output regulation |
| Output voltage | : Single Phase, 230 V ac (+12.5 %, - 20 % V ac) : 3 phase, 415 V ac (+12.5 %, - 20 % V ac) |
| Frequency | : 50 Hz (+3 Hz, -3 Hz) |
| Total Harmonic Distortion | : less than 3% |
| Operating temperature Range: | 0 to 55 deg C |

E. INVERTER STANDARDS :

Inverter should comply with IEC 61683/IS 61683 for efficiency and Measurements and should comply IEC 60068-2 (1, 2, 14, 30) / Equivalent BIS Standard for environmental testing. Inverter should supervise the grid condition continuously and in the event of grid failure (or) under voltage (or) over voltage, Solar System should be disconnected by the circuit Breaker / Auto switch provided in the Inverter.

Power Control : MPPT

Other important Features/Protections required in the INVERTER

- Automatic morning wake-up and nightly shutdown
- Mains (Grid) over-under voltage and frequency protection
- Fool proof protection against ISLANDING.
- Included authentic tracking of the solar array's maximum power operation voltage (MPPT).
- Array ground fault detection.
- LCD and piezoelectric keypad operator interface Menu driven
- Automatic fault conditions reset for all parameters like voltage, frequency and/or black out.
- Surge arresters on AC and DC terminals for over voltage protection from lightning-induced surges.
- INVERTER should be rated to operate at 0 –55 deg. Centigrade unless provision for air conditioning is included in INVERTER
- All parameters should be accessible through an industry standard communication link.
- Overload capacity (for 10 sec) should be 150 % of continuous rating

F. HARMONICS STANDARD:

As per the standard of IEEE 519, the permissible individual harmonics level shall be less than 3% (for both voltage and current harmonics) and Total Harmonics Distortion (THD) for both voltage and current harmonics of the system shall be less than 5%.

TECHNICAL AND INTERCONNECTION REQUIREMENTS:

| | | |
|---|--|--|
| Overall conditions of Service | State Distribution/Supply Code | State Distribution/Supply Code |
| Overall Grid | Central Electricity | Central Electricity |
| Standards | Authority (Grid Standard) Regulations 2010 | Authority (Grid Standard) Regulations 2010 |
| Equipment | BIS / IEC / IEEE | BIS / IEC / IEEE |
| Meters | Central Electricity | Central Electricity |
| | authority (Installation & operation of meters) Regulation 2006 as amended time to time | authority (Installation & operation of meters) Regulation 2006 as amended time to time |
| Safety and supply | Central Electricity Authority(measures of safety and electricity supply) Regulations, 2010 | Central Electricity Authority(measures of safety and electricity supply) Regulations, 2010 |
| Harmonic requirements Harmonic Current | IEEE 519 CEA Technical Standards for (Connectivity of the Distributed Generation Resources) Regulations 2013 | IEEE 519 CEA (Technical Standards for connectivity Of the Distributed Generation Resources) Regulations 2013 |

| | | |
|------------------------------------|--|--|
| Synchronization | IEEE 519 CEA(Technical Standards for Connectivity of the Distributed Generation Resources) Regulations 2013 | Photovoltaic system must be equipped with a grid frequency synchronization device. Every time the generating station is synchronized to the electricity system. It shall not cause voltage fluctuation greater than +/- 5% at point of connection. |
| Voltage | IEEE 519 CEA(Technical Standards for Connectivity of the Distributed Generation Resources) Regulations 2013 | The voltage-operating window should minimize nuisance tripping and should be under operating range of 80% to 110% of the nominal connected voltage. Beyond a clearing time of 2 second, the photovoltaic system must isolate itself from the grid. |
| Flicker | IEEE 519 CEA (Technical standards for connectivity of the Distributed Generation Resources) Regulations 2013 | Operation of Photovoltaic system should not cause voltage flicker in excess of the limits stated in IEC 61000 standards or other equivalent Indian standards, if any |
| Frequency | IEEE 519 CEA (Technical standards for connectivity of the Distributed Generation Resources) Regulations 2013 | When the Distribution system frequency deviates outside the specified conditions (50.5 Hz on upper side and 47.5 Hz on lower side), There should be over and under frequency trip functions with a clearing time of 0.2 seconds. |
| DC injection | IEEE 519 CEA (Technical standards for connectivity of the Distributed Generation Resources) Regulations 2013 | Photovoltaic system should not inject DC power more than 0.5% of full rated output at the interconnection point or 1% of rated inverter output current into output current into distribution system under any operating conditions. |
| Power Factor | IEEE 519 CEA (Technical standards for connectivity of the Distributed Generation Resources) Regulations 2013 | While the output of the inverter is greater than 50%, a lagging power factor of greater than 0.9 should operate. |
| Islanding and Disconnection | IEEE 519 CEA (Technical standards for connectivity of the | The photovoltaic system in the event of fault, voltage or |

| | | |
|------------------------------|--|--|
| | Distributed Generation Resources) Regulations 2013 | frequency variations must island/disconnect itself within IEC standard on |
| Overload and Overheat | IEEE 519 CEA (Technical standards for connectivity of the Distributed Generation Resources) Regulations 2013 | The inverter should have the facility to automatically switch off in case of overload or overheating and should restart when normal conditions are restored. |
| Paralleling Device | IEEE 519 CEA (Technical standards for connectivity of the Distributed Generation Resources) Regulations 2013 | Paralleling device of photovoltaic system shall be capable of withstanding 220% of the normal voltage at the Inter-connection point. |

G. -ELECTRICAL SAFETY, EARTHING AND PROTECTION

Internal Faults: In built protection for internal faults including excess temperature, commutation failure, overload and cooling fan failure (if fitted) is obligatory.

Galvanic Isolation: Galvanic Isolation is required to avoid any DC component being injected into the grid and the potential for AC components appearing at the array.

Over Voltage Protection: Over Voltage Protection against atmospheric lightning discharge to the PV array is required. Protection is to be provided against voltage fluctuations in the grid itself and internal faults in the power conditioner, operational errors and switching transients.

Earth fault supervision: An integrated earth fault device shall have to be provided to detect eventual earth fault on DC side and shall send message to the supervisory system.

Cabling practice: Cable connections must be made using PVC Cu cables, as per BIS standards. All cable connections must be made using suitable terminations for effective contact. The PVC Cu cables must be run in GL trays with covers for protection.

Fast acting semiconductor type current limiting fuses at the main bus-bar to protect from the grid short circuit contribution.

The INVERTER shall include an easily accessible emergency OFF button located at an appropriate position on the unit.

The INVERTER shall include ground lugs for equipment and PV array grounding. The DC circuit ground shall be a solid single point ground connection in accordance with WEC 69042.

All exposed surfaces of ferrous parts shall be thoroughly cleaned, primed, and painted or otherwise suitably protected to survive a nominal 30 years design life of the unit.

The INVERTER enclosure shall be weatherproof and capable of surviving ***climatic changes and should keep the INVERTER*** intact under all conditions in the room where it will be housed. ***The INVERTER shall be located indoor and should be either wall/ pad mounted.*** Moisture condensation and entry of rodents and insects shall be prevented in the INVERTER enclosure.

Components and circuit boards mounted inside the enclosures shall be clearly identified with appropriate permanent designations, which shall also serve to identify the items on the supplied drawings.

All doors, covers, panels and cable exists shall be gasketed or otherwise designed to limit the entry of dust and moisture. All doors shall be equipped with locks. All openings shall be provided with grills or screens with openings no larger than 0.95 cm. (about 3x8 inch).

In the design and fabrication of the INVERTER the site temperature (5° to 55° C), incident sunlight and the effect of ambient temperature on component life shall be considered carefully. Similar consideration shall be given to the heat sinking and thermal for blocking diodes and similar components.

H. Solar PV Modules Mounting Structure

- 1.1. The PV modules shall be mounted on fixed metallic structures having adequate strength and appropriate design, which can withstand the load of the modules and high wind velocities. The support structure shall be hot dip galvanized steel or aluminum.
- 1.2. Detailed specifications for the mounting structure are given below:

| | |
|---|---|
| Wind velocity withstanding capacity | 150km/hour |
| Structure material | Hot dip Galvanized steel with minimum galvanization thickness of 120 microns or Aluminum alloy |
| Bolts, nuts, fasteners, panel mounting clamps | Stainless steel SS 304 |
| Mounting arrangement for RCC flat roofs | With removable concrete ballast made of pre-fabricated PCC(1:2:4), M 15 |
| Mounting arrangement for metal sheet roofs | Mounting directly on the sheet metal ensuring stability and wind withstanding capacity or penetrating the sheet metal and fixing to the sub-structure, ensuring that the roof remains water proof |
| Mounting arrangement for elevated structure | The elevated structure has to be surely anchored to the supporting surface concrete foundations of appropriate weight and depth for elevated structures mounted directly on the ground bolted with Anchor bolts of appropriate strength for elevated structure mounted on RCC structure |
| Mounting arrangement for ground installations | With removable concrete ballast made of pre-fabricated PCC (1:2:4), M 15 assuring enough ground clearance to prevent damage of the module through water, animals and other environmental factors |
| Installation | The structures shall be designed for simple mechanical on site installation. There shall be no requirement of welding or complex machinery at the installation site |
| Minimum distance between roof edge and mounting structure | 0.6m |
| Access for panel cleaning and maintenance | All solar panels must be accessible from the top for cleaning and from the bottom for access to the module junction box |
| Panel tilt angle | North –south orientation with a fixed tilt angle of 11-13 degrees (depending |

| | |
|--|----------------------------|
| | on location) south facing. |
|--|----------------------------|

- 1.3. The prospective Installer shall specify installation details of the solar PV modules and the support structures with lay-out drawings and array connection diagrams. The work shall be carried out as per the designs approved by the Customer.

I. DATA ACQUISITION SYSTEM / PLANT MONITORING

- i. Data Acquisition System shall be provided for each of the solar PV plant above 10 kWp capacity.
- j. Data Logging Provision for plant control and monitoring, time and date stamped system data logs for analysis with the high quality, suitable PC. Metering and Instrumentation for display of systems parameters and status indication to be provided.
- k. Solar Irradiance: An integrating Pyranometer / Solar cell based irradiation sensor (along with calibration certificate) provided, with the sensor mounted in the plane of the array. Readout integrated with data logging system.
- l. Temperature: Temperature probes for recording the Solar panel temperature and/or ambient temperature to be provided complete with readouts integrated with the data logging system
- m. The following parameters are accessible via the operating interface display in real time separately for solar power plant:
 - a. AC Voltage.
 - b. AC Output current.
 - c. Output Power.
 - d. Power factor.
 - e. DC Input Voltage.
 - f. DC Input Current.
 - g. Time Active.
 - h. Time disabled.
 - i. Time Idle.
 - j. Power produced
 - k. Protective function limits (Viz.-AC Over voltage, AC Under voltage, over frequency, under frequency ground fault, PV starting voltage, PV stopping voltage.
- n. All major parameters available on the digital bus and logging facility for energy auditing through the internal microprocessor and read on the digital front panel at any time) and logging facility (the current values, previous values for up to a month and the average values) should be made available for energy auditing through the internal microprocessor and should be read on the digital front panel.
 - vii. PV array energy production: Digital Energy Meters to log the actual value of AC/ DC voltage, Current & Energy generated by the PV system provided. Energy meter along with CT/PT should be of 0.5 accuracy class.
- o. Computerized DC String/Array monitoring and AC output monitoring shall be provided as part of the inverter and/or string/array combiner box or separately.
- p. String and array DC Voltage, Current and Power, Inverter AC output voltage and current (All 3 phases and lines), AC power (Active, Reactive and Apparent), Power Factor and AC energy (All 3 phases and cumulative) and frequency shall be monitored.
- q. Computerized AC energy monitoring shall be in addition to the digital AC energy meter.

- r. The data shall be recorded in a common work sheet chronologically date wise. The data file shall be MS Excel compatible. The data shall be represented in both tabular and graphical form.
- s. All instantaneous data shall be shown on the computer screen.
- t. Software shall be provided for USB download and analysis of DC and AC parametric data for individual plant.
- u. Provision for instantaneous Internet monitoring and download of historical data shall be also incorporated.
- v. Remote Server and Software for centralized Internet monitoring system shall be also provided for download and analysis of cumulative data of all the plants and the data of the solar radiation and temperature monitoring system.
- w. Ambient / Solar PV module back surface temperature shall be also monitored on continuous basis.
- x. Simultaneous monitoring of DC and AC electrical voltage, current, power, energy and other data of the plant for correlation with solar and environment data shall be provided.
- y. Remote Monitoring and data acquisition through Remote Monitoring System software at the owner with latest software/hardware configuration and service connectivity for online / real time data monitoring / control complete to be supplied and operation and maintenance / control to be ensured by the bidder.
- z. The bidders shall be obligated to push real-time plant monitoring data on a specified interval (say 15 minute) through open protocol at receiver location (cloud server) in XML/JSON format, preferably. Suitable provision in this regard will be intimated to the bidders.

J. INTEGRATION OF PV POWER WITH GRID:

The output power from SPV would be fed to the inverters which converts DC produced by SPV array to AC and feeds it into the main electricity grid after synchronization. In case of grid failure, or low or high voltage, solar PV system shall be out of synchronization and shall be disconnected from the grid. Once the DG set comes into service, PV system shall again be synchronized with DG supply and load requirement would be met to the extent of availability of power. 4 pole isolation of inverter output with respect to the grid/ DG power connection need to be provided

The rooftop projects/systems for purpose of grid integration may adhere to voltage level regulations as per APEPDCL latest commercial circulars and also to the latest APSERC orders. In addition to bi-directional meter specifications clause no 8 of annexure I of the net metering policy of the Govt of Andhra Pradesh.

K METER CONFIGURATION OPTIONS

The metering system for rooftop solar system, under net-metering arrangement, shall be as elaborated below which should be applicable till such time the Central Electricity Authority notifies the standards in this matter.

The utility meter (Net-meter) has to be bi-directional meter to register both import grid electricity amount as well as export solar electricity amount.

Bidirectional energy meter with CTs and PT, if required, having the feature of recording both the import and export of energy, besides other parameters shall be as per CEA metering regulations or State Grid code as applicable and of the make & specifications as approved by APEPDCL shall be installed at the cost of the SPV plant owner at the point where interconnection is made between Consumer system and APEPDCL system.

Details of Energy Meters is under:

| SR NO | METER DESCRIPTION | ACCURACY | LOAD OF CONSUMER | VOLTAGE LEVEL |
|-------|--|-----------------------|--------------------------------|------------------------|
| 1 | Single Phase 10-60 A, whole current | Class-I | Up to 7 KW | Single Phase LT 230 V |
| 2 | 3 Phase 10-60 A, whole current | Class-I | More than 7KW & up to 25 KW | Three Phase LT 400 V |
| 3 | LT AC 3-Phase 4-Wires CT operated static DLMC compliant energy meter | Class- 0.5s or better | More than 25 KW & up to 100 KW | Three Phase LT 400 V |
| 4 | HT TPT Meter, DLMS Compliant & AMR Compatible | Class- 0.5s or better | More than 100 KW | Three Phase HT (11 KV) |

Two Meter Configuration without Storage

The metering protocol for 'Grid connected rooftop solar PV system without storage' and location of solar meter and consumer meter shall be in accordance with the schematic below:

-

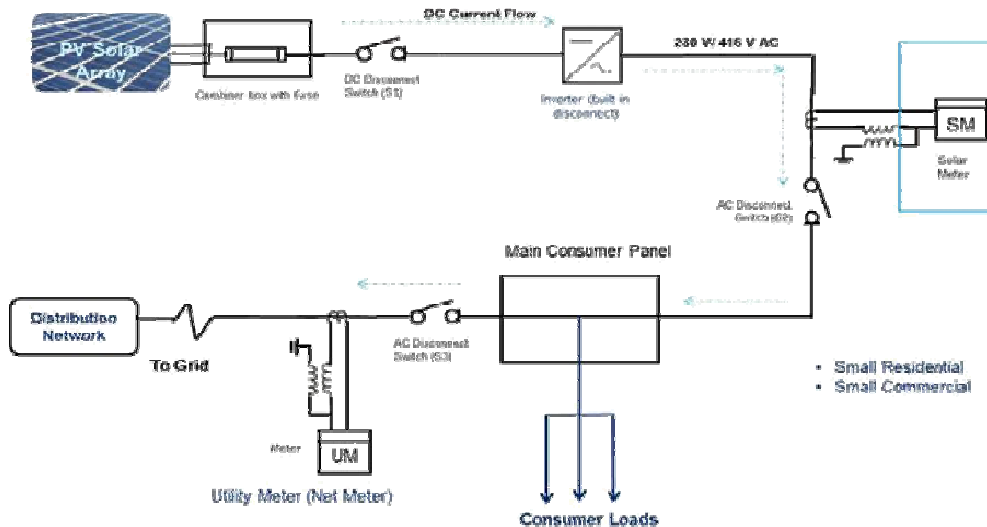
**L- SPV Plant and Metering: -**

All the equipment associated with solar plant installation like solar PV panels, inverters; synchronizer, MPPT, batteries, transformers, cables, junction boxes etc shall be brand new and as per latest specified Indian/IEC standards. Bidirectional energy meter with CTs and PT, if required, having the feature of recording both the import and export of energy, besides other parameters shall be as per CEA metering regulations or State Grid code as applicable and of the make & specifications as approved by APEPDCL shall be

installed at the cost of the SPV plant owner at the point where interconnection is made between Consumer system and APEPDCL system. The Plant owner has option to install the meter and metering equipment procured by APEPDCL or can procure from vendors approved by APEPDCL. If metering system is procured by Plant owner, then the testing and installation of meters including CTs and PT shall be got carried out from APEPDCL as per the latest departmental instructions and no meter rentals shall be charged. APEPDCL shall seal the tested bidirectional energy meters as per prevailing practice of APEPDCL.

M- Connectivity and Protection: -

Solar Photo Voltaic rooftop systems shall be allowed in house auto synchronization or de synchronization facility with distribution system of the licensee at generation voltage level. It will utilize the same service line for excess power injection into the Grid which is currently being used by the consumer for drawl of power from utility network and shall operate in synchronization with APEPDCL system provided that such injection of power from the rooftop solar PV system shall not be more than 90% of the total consumption from the licensee's supply by the consumer in a Settlement Period. It shall be mandatory for the solar rooftop generator to provide an appropriate protection system on their incoming side or consumer premises with the feature of "Islanding the SPV generator", so as to achieve isolation of consumer power-system from utility power-system during grid failure including protection from voltage / lightning surges. The Power Conditioning Unit of the SPV plant shall have features to filter out harmonics and other distortions before injecting the energy into APEPDCL system

N- Operation and Maintenance: -

(a) The solar plant shall comply with the relevant standards specified by the MNRE /BIS and CEA. The responsibility of operation and maintenance of the solar photo voltaic (SPV) generator including all accessories and apparatus lies with the consumer. The design and installation of the rooftop SPV should be equipped with appropriately rated protective devices to sense any abnormality in the system and carry out automatic isolation of the SPV from the grid. The inverters used should meet the necessary quality requirements and should be certified for their quality by appropriate authority; the protection logics should be tested before commissioning of the plant.

(b) The automatic isolation or islanding protection of SPV should be ensured for, no grid supply and low or over voltage conditions and within the required response time. Adequate rated fuses and fast acting circuit breakers on input and output side of the inverters and disconnect/isolating switches to isolate DC and AC system for maintenance shall be provided. The consumer should provide for all internal safety and protective mechanism for earthing, surge, DC ground fault, transients etc.

(c) To prevent back feeding and possible accidents when maintenance works are carried out by DISCOM personnel, Double pole/Triple pole with neutral isolating disconnect switches which can be locked by DISCOM personnel should be provided. This is in addition to automatic sensing and isolating on grid supply failure etc and in addition to internal

disconnect switches. In the event of DISCOM LT/HT supply failure, the consumer has to ensure that there will not be any solar power being fed to the LT/HT grid of DISCOM. The consumer is solely responsible for any accident to human beings/animals whatsoever (fatal/non-fatal/departamental/non-departamental) that may occur due to back feeding from the SPV plant when the grid supply is off. DISCOM reserves the right to disconnect the installation at any time in the event of damage to its grid, meter, etc. or to prevent accident or damage.

(d) The consumer shall abide by all the codes and regulations issued by the Commission to the extent applicable and in force from time to time. The consumer shall comply with APERC/DISCOM/CEA requirements with respect to safe, secure and reliable function of the SPV plant and the grid. The power injected into the grid shall be of the required quality in respect of wave shape, frequency, absence of DC components etc. (e) The consumer shall restrict the harmonic generation within the limit specified in the agreement or specified by the Central Electricity Authority as and when such regulation is issued.

(f) The SPG (individual homes/commercial establishments) may establish LT grid interactive solar power plant in the roof top or elevated surface with the following options: (i). Grid interactive solar PV system without battery. (ii). Grid interactive solar PV system with battery backup.

However, in both the options, features as per section clause (b) & (c) above shall be available so as to ensure islanding of the SPV system & prevent back feeding to Grid system of APEPDCL.

(g) The inverter standard shall be such that it should not allow solar power/battery power to extend to DISCOM's LT grid on failure of DISCOM's grid supply, irrespective of the LT connectivity options. The required inverter standard for three phase and single phase solar power are furnished in Annexure-III. (8) The inverter should be a sine wave inverter. Harmonic standards shall be as per IEEE 519.

2.13. Penalty or Compensation: - In case of failure of net metering system, the provisions of penalty or compensation shall be as per the provisions of the standard of performance regulations for distribution licensee.

O- Interconnection with the Grid, Standards & Safety

The interconnection of the rooftop solar system with the network of the distribution licensee shall conform to the standards as provided in Central Electricity Authority (Technical Standard for Connectivity of the Distributed Generation Resources) Regulations, 2013 as amended from time to time. 8.2 The interconnection of the rooftop solar system with the distribution system of the licensee shall conform to the relevant provisions of the Central Electricity Page 8 of 13 Authority (Measures relating to Safety and Electric Supply),

Regulations, 2010, as amended from time to time. 8.3 The grid interactive rooftop solar system may be installed with or without battery backup. Provided that where the rooftop solar system is installed with battery backup (full load backup/partial load backup), the inverter shall have separate backup wiring to prevent the battery/decentralized generation power to flow into the grid in the absence of grid supply and manual isolation switch shall also be provided. 8.4 The consumer shall be responsible for safe operation, maintenance and rectification of any defect of the rooftop solar system up to the point of Net Meter beyond which the responsibility of safe operation, maintenance and rectification of any defect in the system, including the Net Meter, shall be that of the licensee. 8.5 The consumer shall provide appropriate protection for islanding of SPV system from the network of distribution licensee during grid/supply failure. 8.6 The licensee shall have the right to disconnect the rooftop solar system at any time in the event of possible threat/damage, from such rooftop solar system to its distribution system, to prevent any accident or damage, without any notice.

Section VII. Sample Forms and Procedures

| | |
|---|-----|
| 1. Bid Forms and Price Schedules | 133 |
| Form of Bid Security (Bank Guarantee) | 143 |
| Form of Bid Security (Bid Bond)..... | 144 |
| 3. Form of Contract Agreement | 146 |
| 4. Performance Security Forms..... | 164 |
| 5. Bank Guarantee Form for Advance Payment | 169 |
| 6. Form of Completion Certificate..... | 171 |
| 7. Form of Operational Acceptance Certificate | 172 |
| 8. Change Order Procedures | 173 |

1. Bid Forms and Price Schedules

1.1 Bid Form—Single Stage Bidding

Date: _____

[Name of Contract]

To: *[Name and address of Employer]*

Ladies and/or Gentlemen,

Having examined the bidding documents, including Addendum Nos. *[insert numbers]*, the receipt of which is hereby acknowledged, we, the undersigned, offer to design, manufacture, test, deliver, install, precommission and commission the Facilities under the above-named Contract in full conformity with the said bidding documents for the sum of: *[amount of foreign currency in words]*, *[amount in figures]*, **and** *[amount of local currency in words]*, *[amount in figures]* or such other sums as may be determined in accordance with the terms and conditions of the Contract. The above amounts are in accordance with the Price Schedules attached herewith and are made part of this bid.

We undertake, if our bid is accepted, to commence the Facilities and to achieve Completion within the respective times stated in the bidding documents.

If our bid is accepted, we undertake to provide an advance payment security and a performance security in the form, in the amounts, and within the times specified in the bidding documents.

We accept the appointment of *[name proposed in Bid Data Sheet]* as the Adjudicator.

or

We do not accept the appointment of *[name proposed in Bid Data Sheet]* as the Adjudicator, and we propose instead that *[name]* be appointed as Adjudicator, whose résumé and hourly fees are attached.

We agree to abide by this bid, which consists of this letter and Attachments 1 through *[number]* hereto, for a period of *[number]* days from the date fixed for submission of bids as stipulated in the bidding documents, and it shall remain binding upon us and may be accepted by you at any time before the expiration of that period.

Commissions or gratuities, if any, paid or to be paid by us to agents relating to this Bid, and to contract execution if we are awarded the contract, are listed below

| <u>Name and address of agent</u> | <u>Amount and Currency</u> | <u>Purpose of Commission</u> |
|--------------------------------------|--------------------------------|----------------------------------|
|--------------------------------------|--------------------------------|----------------------------------|

or gratuity

| | | |
|-------|-------|-------|
| _____ | _____ | _____ |
| _____ | _____ | _____ |
| _____ | _____ | _____ |

(if none, state "none").

Until a formal contract is prepared and executed between us, this bid, together with your written acceptance thereof and your notification of award, shall constitute a binding contract between us.

We understand that you are not bound to accept the lowest or any bid you may receive.

Dated this _____ day of _____, 19_____

[signature]

In the capacity of _____
[position]

Duly authorized to sign this bid for and on behalf of _____
[name of Bidder]

Attachments: *[In accordance with ITB Sub-Clause 9.3, plus any additional attachment either specified by the Employer in the Bid Data Sheet or included by the Bidder. In this regard, the Employer may include in the bidding document, as an Attachment to the Bid Form, a list of "Bidding Data," including the most important data to be provided by the Bidder (e.g., Time for Completion, Functional Guarantees, etc.).]*

1.2 Price Schedules

In order to receive consistent and responsive bids, it is recommended that Employers include a PREAMBLE to the Price Schedules indicating exactly what is required of bidders when completing and pricing their bids.

The following Preamble is given as an example only. Employers are responsible for ensuring that the Preamble included in the bidding documents is complete and appropriate for the contract in question.

PREAMBLE

General

1. The Price Schedules are divided into separate Schedules as follows:

Schedule No. 1 Plant and Equipment (including Mandatory Spare Parts) Supplied from Abroad

Schedule No. 2 Plant and Equipment (including Mandatory Spare Parts) Supplied from within the Employer's Country

Schedule No. 3 Local Transportation

Schedule No. 4 Installation Services

Schedule No. 5 Grand Summary

Schedule No. 6 Recommended Spare Parts

Add any other Schedules as appropriate

2. The Schedules do not generally give a full description of the plant and equipment to be supplied and the services to be performed under each item. Bidders shall be deemed to have read the Technical Specifications and other sections of the bidding documents and reviewed the Drawings to ascertain the full scope of the requirements included in each item prior to filling in the rates and prices. The entered rates and prices shall be deemed to include for the full scope as aforesaid, including overheads and profit.
3. If bidders are unclear or uncertain as to the scope of any item, they shall seek clarification in accordance with the Instructions to Bidders in the bidding documents prior to submitting their bid.

Pricing

4. Prices shall be filled in indelible ink, and any alterations necessary due to errors, etc., shall be initialed by the Bidder.

As specified in the Bid Data Sheet and Special Conditions of Contract, prices shall be fixed and firm for the duration of the Contract, or prices shall be subject to adjustment in accordance with the corresponding Appendix (Price Adjustment) to the Contract Agreement.

5. Bid prices shall be quoted in the manner indicated and in the currencies specified in the Instructions to Bidders in the bidding documents.

For each item, bidders shall complete each appropriate column in the respective Schedules, giving the price breakdown as indicated in the Schedules.

Prices given in the Schedules against each item shall be for the scope covered by that item as detailed in the Technical Specifications, Drawings or elsewhere in the bidding documents.

6. Where there are errors between the total of the amounts given under the column for the price breakdown and the amount given under the Total Price, the former shall prevail and the latter will be corrected accordingly.

Where there are errors between the total of the amounts of Schedule Nos. 1 to 4 and the amount given in Schedule No. 5 (Grand Summary), the former shall prevail and the latter will be corrected accordingly.

Where there are discrepancies between amounts stated in figures and amounts stated in words, the amounts stated in words shall prevail.

7. Payments will be made to the Contractor in the currency or currencies indicated under each respective item.
8. Items left blank will be deemed to have been included in other items. The TOTAL for each Schedule and the TOTAL of the Grand Summary shall be deemed to be the total price for executing the Facilities and sections thereof in complete accordance with the Contract, whether or not each individual item has been priced.
9. When requested by the Employer for the purposes of making payments or part payments, valuing variations or evaluating claims, or for such other purposes as the Employer may reasonably require, the Contractor shall provide the Employer with a breakdown of any composite or lump sum items included in the Schedules.

Schedules of Rates and Prices

Schedule No. 1. Plant, Equipment, and Mandatory Spare Parts Supplied from Abroad

| Item | Description | Code ¹ | Qty. <i>(1)</i> | Unit Price ² | | Total Price ² <i>(1) x (3)</i> |
|---|-------------|-------------------|--------------------|--------------------------|--------------------------|--|
| | | | | FOB or FCA <i>(2)</i> | CIF or CIP <i>(3)</i> | |
| | | | | | | |
| TOTAL (to Schedule No. 5. Grand Summary) | | | | | | |

| | | |
|------|---------|---------------------------|
| Code | Country | |
| | | Name of Bidder _____ |
| | | Signature of Bidder _____ |

¹ Bidders shall enter a code representing the country of origin of all imported plant and equipment.

² Specify currency.

**Schedule No. 2. Plant, Equipment, and Mandatory Spare Parts Supplied from Within
the Employer's Country**

| Item | Description | Qty. <i>(1)</i> | EXW Unit Price ¹ <i>(2)</i> | EXW Total Price ¹ <i>(1) x (2)</i> |
|--|-------------|---|---|--|
| | | | | |
| TOTAL (to Schedule No. 5. Grand Summary) | | | | |
| | | Name of Bidder _____ Signature of Bidder _____ | | |

¹ Specify currency in accordance with specifications in Bid Data Sheet under ITB Sub-Clause 12.1 (b) in Single Stage Bid, or ITB Sub-Clause 23.1 (b) in Two Stage Bid.

Schedule No. 3. Local Transportation, Insurance and Other Incidental Services

| Item | Description | Qty. <i>(1)</i> | Unit Price ¹ | | Total Price ¹ <i>(1) x (2)</i> |
|--|-------------|--------------------|---|--|--|
| | | | Local Currency Portion <i>(2)</i> | Foreign Currency Portion <i>(optional)</i> | |
| | | | | | |
| TOTAL (to Schedule No. 5. Grand Summary) | | | | | |
| | | | Name of Bidder _____ Signature of Bidder _____ | | |

¹ Specify currency in accordance with specifications in Bid Data Sheet under ITB Sub-Clause 12.1 (c) in Single Stage Bid, or ITB Sub-Clause 23.1 (c) in Two Stage Bid.

Schedule No. 4. Installation Services

| Item | Description | Qty. <i>(1)</i> | Unit Price ¹ | | Total Price ¹ | | |
|---|-------------|------------------------|--|--|---------------------------------|-------------------------------|--|
| | | | Foreign Currency Portion <i>(2)</i> | Local Currency Portion <i>(3)</i> | Foreign <i>(1) x (2)</i> | Local <i>(1) x (3)</i> | |
| | | | | | | | |
| TOTAL (to Schedule No. 5. Grand Summary) | | | | | | | |
| Name of Bidder _____ Signature of Bidder _____ | | | | | | | |

¹ Specify currency in accordance with specifications in Bid Data Sheet under ITB Sub-Clause 12.1 (c) in Single Stage Bid, or ITB Sub-Clause 23.1 (c) in Two Stage Bid.

Schedule No. 5. Grand Summary

| Item | Description | Total Price ¹ | |
|----------------------------|---|---|-------|
| | | Foreign | Local |
| | Total Schedule No. 1. Plant, Equipment, and Mandatory Spare Parts Supplied from Abroad | | |
| | Total Schedule No. 2. Plant, Equipment, and Mandatory Spare Parts Supplied from Within the Employer's Country | | |
| | Total Schedule No. 3. Local Transportation, Insurance and Other Incidental Services | | |
| | Total Schedule No. 4. Installation Services | | |
| TOTAL (to Bid Form) | | | |
| | | Name of Bidder _____ Signature of Bidder _____ | |

¹ Specify currency in accordance with specifications in Bid Data Sheet under ITB Sub-Clause 12.1 in Single Stage Bid, or ITB Sub-Clause 23.1 in Two Stage Bid.

Form of Bid Security (Bank Guarantee)

[Bank's Name, and Address of Issuing Branch or Office]

Beneficiary: _____ *[Name and Address of Employer]*

Date: _____

BID GUARANTEE No.: _____

We have been informed that *[name of the Bidder]* (hereinafter called "the Bidder") has submitted to you its bid dated (hereinafter called "the Bid") for the execution of *[name of contract]* under Invitation for Bids No. *[IFB number]* ("the IFB").

Furthermore, we understand that, according to your conditions, bids must be supported by a bid guarantee.

At the request of the Bidder, we *[name of Bank]* hereby irrevocably undertake to pay you any sum or sums not exceeding in total an amount of *[amount in figures]* (*[amount in words]*) upon receipt by us of your first demand in writing accompanied by a written statement stating that the Bidder is in breach of its obligation(s) under the bid conditions, because the Bidder:

- (a) has withdrawn its Bid during the period of bid validity specified by the Bidder in the Form of Bid; or
- (b) does not accept the correction of errors in accordance with the Instructions to Bidders (hereinafter "the ITB") of the IFB; or
- (c) having been notified of the acceptance of its Bid by the Employer during the period of bid validity, (i) fails or refuses to execute the Contract Form, if required, or (ii) fails or refuses to furnish the performance security, in accordance with the ITB.

This guarantee will expire: (a) if the Bidder is the successful bidder, upon our receipt of copies of the contract signed by the Bidder and the performance security issued to you upon the instruction of the Bidder; or (b) if the Bidder is not the successful bidder, upon the earlier of (i) our receipt of a copy of your notification to the Bidder of the name of the successful bidder; or (ii) twenty-eight days after the expiration of the Bidder's Bid.

Consequently, any demand for payment under this guarantee must be received by us at the office on or before that date.

This guarantee is subject to the Uniform Rules for Demand Guarantees, ICC Publication No. 458.

[signature(s)]

Form of Bid Security (Bid Bond)

BOND NO. _____

BY THIS BOND [*name of Bidder*] as Principal (hereinafter called “the Principal”), and [*name, legal title, and address of surety*], **authorized to transact business in** [*name of country of Employer*], as Surety (hereinafter called “the Surety”), are held and firmly bound unto [*name of Employer*] as Obligee (hereinafter called “the Employer”) in the sum of [*amount of Bond*]¹ [*amount in words*], for the payment of which sum, well and truly to be made, we, the said Principal and Surety, bind ourselves, our successors and assigns, jointly and severally, firmly by these presents.

WHEREAS the Principal has submitted a written Bid to the Employer dated the ___ day of _____, 20___, for the construction of [*name of Contract*] (hereinafter called the “Bid”).

NOW, THEREFORE, THE CONDITION OF THIS OBLIGATION is such that if the Principal:

- (1) withdraws its Bid during the period of bid validity specified in the Form of Bid; or
- (2) refuses to accept the correction of its Bid Price, pursuant to Sub-Clause 29.2 of the Instructions to Bidders; or
- (3) having been notified of the acceptance of its Bid by the Employer during the period of Bid validity;
 - (a) fails or refuses to execute the Form of Agreement in accordance with the Instructions to Bidders, if required; or
 - (b) fails or refuses to furnish the Performance Security in accordance with the Instructions to Bidders;

then the Surety undertakes to immediately pay to the Employer up to the above amount upon receipt of the Employer’s first written demand, without the Employer having to substantiate its demand, provided that in its demand the Employer shall state that the demand arises from the occurrence of any of the above events, specifying which event(s) has occurred.

The Surety hereby agrees that its obligation will remain in full force and affect up to and including the date 28 days after the date of expiration of the Bid validity as stated in the Invitation to Bid or extended by the Employer at any time prior to this date, notice of which extension(s) to the Surety being hereby waived.

¹ The amount of the Bond shall be denominated in the currency of the Employer’s country or the equivalent amount in a freely convertible currency.

IN TESTIMONY WHEREOF, the Principal and the Surety have caused these presents to be executed in their respective names this ____ day of _____ 20__.

Principal: _____

Surety: _____

Corporate Seal (where appropriate)

(Signature)

(Signature)

(Printed name and title)

(Printed name and title)

3. Form of Contract Agreement

THIS CONTRACT AGREEMENT is made the _____ day of _____, 19__.

BETWEEN

(1) *[Name of Employer]*, a corporation incorporated under the laws of *[country of Employer]* and having its principal place of business at *[address of Employer]* (hereinafter called “the Employer”), and (2) *[name of Contractor]*, a corporation incorporated under the laws of *[country of Contractor]* and having its principal place of business at *[address of Contractor]* (hereinafter called “the Contractor”).

WHEREAS the Employer desires to engage the Contractor to design, manufacture, test, deliver, install, complete and commission certain Facilities, viz. *[list of facilities]* (“the Facilities”) and the Contractor have agreed to such engagement upon and subject to the terms and conditions hereinafter appearing.

NOW IT IS HEREBY AGREED as follows:

Article 1.
Contract
Documents

1.1 Contract Documents (Reference GCC Clause 2)

The following documents shall constitute the Contract between the Employer and the Contractor, and each shall be read and construed as an integral part of the Contract:

- (a) This Contract Agreement and the Appendixes hereto
- (b) Bid and Price Schedules submitted by the Contractor
- (c) Special Conditions of Contract
- (d) General Conditions of Contract
- (e) Technical Specifications and Drawings
- (f) Procedures (as listed)
- (g) *Any other documents shall be added here*

1.2 Order of Precedence (Reference GCC Clause 2)

In the event of any ambiguity or conflict between the Contract Documents listed above, the order of precedence shall be the order in which the Contract Documents are listed in Article 1.1 (Contract Documents) above.

1.3 Definitions (Reference GCC Clause 1)

Capitalized words and phrases used herein shall have the same meanings as are ascribed to them in the General Conditions of Contract.

Article 2.
Contract Price
and Terms of
Payment

2.1 Contract Price (Reference GCC Clause 11)

The Employer hereby agrees to pay to the Contractor the Contract Price in consideration of the performance by the Contractor of its obligations hereunder. The Contract Price shall be the aggregate of: *[amount of foreign currency in words]*, *[amount in figures]* as specified in Price Schedule No. 5 (Grand Summary), and *[amount of local currency in words]*, *[amount in figures]*, or such other sums as may be determined in accordance with the terms and conditions of the Contract.

2.2 Terms of Payment (Reference GCC Clause 12)

The terms and procedures of payment according to which the Employer will reimburse the Contractor are given in the corresponding Appendix (Terms and Procedures of Payment) hereto.

The Employer shall instruct its bank to issue an irrevocable confirmed documentary credit made available to the Contractor in a bank in the country of the Contractor. The credit shall be for an amount of *[insert an amount equal to the total named in Schedule 1 less the advance payment to be made for Plant and Equipment supplied from abroad]*; and shall be subject to the Uniform Customs and Practice for Documentary Credits 1993 Revision, ICC Publication No. 500.

In the event that the amount payable under Schedule No. 1 is adjusted in accordance with GCC 11.2 or with any of the other terms of the Contract, the Employer shall arrange for the documentary credit to be amended accordingly.

[The Employer may want to insert a similar provision for the payment of the items listed in Schedule 2.]

Article 3.
Effective Date
for
Determining
Time for
Completion

3.1 Effective Date (Reference GCC Clause 1)

The Time of Completion of the Facilities shall be determined from the date when all of the following conditions have been fulfilled:

- (a) This Contract Agreement has been duly executed for and on behalf of the Employer and the Contractor;
- (b) The Contractor has submitted to the Employer the performance security and the advance payment guarantee;
- (c) The Employer has paid the Contractor the advance payment

- (d) The Contractor has been advised that the documentary credit referred to in Article 2.2 above has been issued in its favor.

Each party shall use its best efforts to fulfill the above conditions for which it is responsible as soon as practicable.

- 3.2 If the conditions listed under 3.1 are not fulfilled within two (2) months from the date of this Contract notification because of reasons not attributable to the Contractor, the parties shall discuss and agree on an equitable adjustment to the Contract Price and the Time for Completion and/or other relevant conditions of the Contract.

**Article 4.
Appendixes**

- 4.1 The Appendixes listed in the attached List of Appendixes shall be deemed to form an integral part of this Contract Agreement.
- 4.2 Reference in the Contract to any Appendix shall mean the Appendixes attached hereto, and the Contract shall be read and construed accordingly.

IN WITNESS WHEREOF the Employer and the Contractor have caused this Agreement to be duly executed by their duly authorized representatives the day and year first above written.

Signed by, for and on behalf of the Employer

[Signature]

[Title]

in the presence of _____

Signed by, for and on behalf of the Contractor

[Signature]

[Title]

in the presence of _____

APPENDIXES

- Appendix 1 Terms and Procedures of Payment
- Appendix 2 Price Adjustment
- Appendix 3 Insurance Requirements
- Appendix 4 Time Schedule
- Appendix 5 List of Approved Subcontractors
- Appendix 6 Scope of Works and Supply by the Employer
- Appendix 7 List of Documents for Approval or Review
- Appendix 8 Functional Guarantees

Appendix 1. Terms and Procedures of Payment

In accordance with the provisions of GCC Clause 12 (Terms of Payment), the Employer shall pay the Contractor in the following manner and at the following times, on the basis of the Price Breakdown given in the section on Price Schedules. Payments will be made in the currencies quoted by the Bidder unless otherwise agreed between the parties. Applications for payment in respect of part deliveries may be made by the Contractor as work proceeds.

TERMS OF PAYMENT

Schedule No. 1. Plant and Equipment Supplied from Abroad- Not Applicable

Schedule No. 2. Plant and Equipment Supplied from within the Employer's Country

In respect of plant and equipment supplied from within the Employer's country, the following payments shall be made:

Ten percent (10%) of the total EXW amount as an advance payment against receipt of invoice, and an irrevocable advance payment security for the equivalent amount made out in favor of the Employer. The advance payment security may be reduced in proportion to the value of the plant and equipment delivered to the site, as evidenced by shipping and delivery documents.

Eighty percent (80%) of the total or pro rata EXW amount upon *Incoterm* "Ex-Works," upon delivery to the site within forty-five (45) days after receipt of invoice.

Five percent (5%) of the total or pro rata EXW amount upon issue of the Completion Certificate, within forty-five (45) days after receipt of invoice.

Five percent (5%) of the total or pro rata EXW amount upon issue of the Operational Acceptance Certificate, within forty-five (45) days after receipt of invoice.

Schedule No. 3. Local Transportation

In respect of local transportation for both the foreign currency (where applicable) and the local currency portions, the following payments shall be made:

Ten percent (10%) of the total local transportation amount as an advance payment against receipt of invoice, and an irrevocable advance payment security for the equivalent amount made out in favor of the Employer. The advance payment security

may be reduced in proportion to the value of the Plant and Equipment delivered to the site, as evidenced by shipping and delivery documents.

Ninety percent (90%) of the total or pro rata local transportation amount upon delivery to the site within forty-five (45) days after receipt of invoice.

Schedule No. 4. Installation Services

In respect of installation services for both the foreign and local currency portions, the following payments shall be made:

Ten percent (10%) of the total installation services amount as an advance payment against receipt of invoice, and an irrevocable advance payment security for the equivalent amount made out in favor of the Employer. The advance payment security may be reduced in proportion to the value of work performed by the Contractor as evidenced by the invoices for installation services.

Eighty percent (80%) of the measured value of work performed by the Contractor, as identified in the said Program of Performance, during the preceding month, as evidenced by the Employer's authorization of the Contractor's application, will be made monthly within forty-five (45) days after receipt of invoice.

Five percent (5%) of the total or pro rata value of installation services performed by the Contractor as evidenced by the Employer's authorization of the Contractor's monthly applications, upon issue of the Completion Certificate, within forty-five (45) days after receipt of invoice.

Five percent (5%) of the total or pro rata value of installation services performed by the Contractor as evidenced by the Employer's authorization of the Contractor's monthly applications, upon issue of the Operational Acceptance Certificate, within forty-five (45) days after receipt of invoice.

In the event that the Employer fails to make any payment on its respective due date, the Employer shall pay to the Contractor interest on the amount of such delayed payment at the rate of *[insert a figure that may be different for the foreign and local currency portions and a figure that reflects the cost of money in the respective currencies]* percent (___%) per month for period of delay until payment has been made in full.

PAYMENT PROCEDURES

The procedures to be followed in applying for certification and making payments shall be as follows:

Appropriate procedures, normally through letters of credit, are to be inserted (including forms and certificates annexed as appropriate) by the Employer in the bidding documents.

Appendix 2. Price Adjustment- Not Applicable

Where the Contract Period (excluding the Defects Liability Period) exceeds twenty four (24) months, it is normal procedure that prices payable to the Contractor shall be subject to adjustment during the performance of the Contract to reflect changes occurring in the cost of labor and material components. In such cases the bidding documents shall include in this Appendix 2 a formula of the following general type, pursuant to GCC Sub-Clause 11.2.

Where Contracts are of a shorter duration than eighteen (18) months or in cases where there is to be no Price Adjustment, the following provision shall not be included. Instead, it shall be indicated under this Appendix 2 that the prices are to remain firm and fixed for the duration of the Contract.

Sample Price Adjustment Formula

Prices payable to the Contractor, in accordance with the Contract, shall be subject to adjustment during performance of the Contract to reflect changes in the cost of labor and material components, in accordance with the following formula:

$$P_1 = P_0 \times \left(a + b \frac{L_1}{L_0} + c \frac{M_1}{M_0} \right) - P_0$$

in which:

P_1 = adjustment amount payable to the Contractor

P_0 = Contract price (base price)

a = fixed element representing profit and overhead in Contract price ($a = ___ \%$)

b = estimated percent of labor component in Contract price ($b = ___ \%$)

c = estimated percent of plant & equipment component in Contract price ($c = ___ \%$)

L_0, L_1 = labor indexes applicable to the appropriate industry in the country of origin on the base date and the date for adjustment, respectively

M_0, M_1 = material indexes for the major raw materials in the country of origin on the base date and the date for adjustment, respectively

The sum of the three coefficients a , b and c shall be one (1) in every application of the formula.

Conditions Applicable To Price Adjustment

The Bidder shall indicate the source of labor and materials indexes and the base date indexes in its bid.

| <u>Item</u> | <u>Source of Indexes Used</u> | <u>Base Date Indexes</u> |
|-------------|-------------------------------|--------------------------|
|-------------|-------------------------------|--------------------------|

The base date shall be the date thirty (30) days prior to the Bid closing date.

The date of adjustment shall be the mid-point of the period of manufacture or installation of component or Plant.

The following conditions shall apply:

- (a) Price adjustment will be applied only if the resulting increase or decrease is more than two percent (2%) of the Contract price.
- (b) No price increase will be allowed beyond the original delivery date unless covered by an extension of time awarded by the Employer under the terms of the Contract. No price increase will be allowed for periods of delay for which the Contractor is responsible. The Employer will, however, be entitled to any price decrease occurring during such periods of delay.
- (c) The total adjustment (plus or minus) shall be subject to a ceiling amount of ___ percent (___%) of the Contract price.
- (d) If the currency in which the Contract price, P_0 , is expressed is different from the currency of the country of origin of the labor and/or materials indexes, a correction factor will be applied to avoid incorrect adjustments of the Contract price. The correction factor shall correspond to the ratio of exchange rates between the two currencies on the base date and the date for adjustment as defined above.
- (e) No price adjustment shall be payable on the portion of the Contract price paid to the Contractor as an advance payment.

Note: For complex Plant supply and installation involving several sources of supply and/or a substantial amount of installation works, a family of formulas may be necessary, with provision for the usage of Contractor's equipment in the works formula.

Appendix 3. Insurance Requirements

Insurances To Be Taken Out By The Contractor

In accordance with the provisions of GCC Clause 34, the Contractor shall at its expense take out and maintain in effect, or cause to be taken out and maintained in effect, during the performance of the Contract, the insurances set forth below in the sums and with the deductibles and other conditions specified. The identity of the insurers and the form of the policies shall be subject to the approval of the Employer, such approval not to be unreasonably withheld.

(a) Cargo Insurance

Covering loss or damage occurring, while in transit from the supplier's or manufacturer's works or stores until arrival at the Site, to the Facilities (including spare parts therefor) and to the construction equipment to be provided by the Contractor or its Subcontractors.

| <u>Amount</u> | <u>Deductible limits</u> | <u>Parties insured</u> | <u>From</u> | <u>To</u> |
|---------------------------|--------------------------|------------------------|----------------|----------------|
| <i>[in currency(ies)]</i> | | <i>[names]</i> | <i>[place]</i> | <i>[place]</i> |

(b) Installation All Risks Insurance

Covering physical loss or damage to the Facilities at the Site, occurring prior to completion of the Facilities, with an extended maintenance coverage for the Contractor's liability in respect of any loss or damage occurring during the defect liability period while the Contractor is on the Site for the purpose of performing its obligations during the defect liability period.

| <u>Amount</u> | <u>Deductible limits</u> | <u>Parties insured</u> | <u>From</u> | <u>To</u> |
|---------------------------|--------------------------|------------------------|----------------|----------------|
| <i>[in currency(ies)]</i> | | <i>[names]</i> | <i>[place]</i> | <i>[place]</i> |

(c) Third Party Liability Insurance

Covering bodily injury or death suffered by third parties (including the Employer's personnel) and loss of or damage to property (including the Employer's property and any parts of the Facilities that have been accepted by the Employer) occurring in connection with the supply and installation of the Facilities.

| <u>Amount</u> | <u>Deductible limits</u> | <u>Parties insured</u> | <u>From</u> | <u>To</u> |
|---------------------------|--------------------------|------------------------|----------------|----------------|
| <i>[in currency(ies)]</i> | | <i>[names]</i> | <i>[place]</i> | <i>[place]</i> |

(d) Automobile Liability Insurance

Covering use of all vehicles used by the Contractor or its Subcontractors (whether or not owned by them) in connection with the supply and installation of the Facilities. Comprehensive insurance in accordance with statutory requirements.

(e) Workers' Compensation

In accordance with the statutory requirements applicable in any country where the Facilities or any part thereof is executed.

(f) Employer's Liability

In accordance with the statutory requirements applicable in any country where the Facilities or any part thereof is executed.

(g) Other Insurances

The Contractor is also required to take out and maintain at its own cost the following insurances:

Details:

| <u>Amount</u> | <u>Deductible limits</u> | <u>Parties insured</u> | <u>From</u> | <u>To</u> |
|---------------------------|--------------------------|------------------------|----------------|----------------|
| <i>[in currency(ies)]</i> | | <i>[names]</i> | <i>[place]</i> | <i>[place]</i> |

The Employer shall be named as co-insured under all insurance policies taken out by the Contractor pursuant to GCC Sub-Clause 34.1, except for the Third Party Liability, Workers' Compensation and Employer's Liability Insurances, and the Contractor's Subcontractors shall be named as co-insureds under all insurance policies taken out by the Contractor pursuant to GCC Sub-Clause 34.1, except for the Cargo, Workers' Compensation and Employer's Liability Insurances. All insurer's rights of subrogation against such co-insureds for losses or claims arising out of the performance of the Contract shall be waived under such policies.

Insurances To Be Taken Out By The Employer

The Employer shall at its expense take out and maintain in effect during the performance of the Contract the following insurances.

Details:

| <u>Amount</u> <i>[in currency(ies)]</i> | <u>Deductible limits</u> | <u>Parties insured</u> <i>[names]</i> | <u>From</u> <i>[place]</i> | <u>To</u> <i>[place]</i> |
|--|--------------------------|--|-------------------------------|-----------------------------|
|--|--------------------------|--|-------------------------------|-----------------------------|

Appendix 4. Time Schedule

Appendix 5. List of Approved Subcontractors

The following Subcontractors are approved for carrying out the item of the facilities indicated. Where more than one Subcontractor is listed, the Contractor is free to choose between them, but it must notify the Employer of its choice in good time prior to appointing any selected Subcontractor. In accordance with GCC Sub-Clause 19.1, the Contractor is free to submit proposals for Subcontractors for additional items from time to time. No Subcontracts shall be placed with any such Subcontractors for additional items until the Subcontractors have been approved in writing by the Employer and their names have been added to this list of Approved Subcontractors.

Item of Facilities

Approved Subcontractors

Nationality

Appendix 6. Scope of Works and Supply by the Employer

The following personnel, facilities, works and supplies will be provided/supplied by the Employer, and the provisions of GCC Clauses 10, 21 and 24 shall apply as appropriate.

All personnel, facilities, works and supplies will be provided by the Employer in good time so as not to delay the performance of the Contractor, in accordance with the approved Time Schedule and Program of Performance pursuant to GCC Sub-Clause 18.2.

Unless otherwise indicated, all personnel, facilities, works and supplies will be provided free of charge to the Contractor.

Personnel

Charge to Contractor (if any)

Facilities

Charge to Contractor (if any)

Works

Charge to Contractor (if any)

Supplies

Charge to Contractor (if any)

Appendix 7. List of Documents for Approval or Review

Pursuant to GCC Sub-Clause 20.3.1, the Contractor shall prepare, or cause its Subcontractor to prepare, and present to the Project Manager in accordance with the requirements of GCC Sub-Clause 18.2 (Program of Performance), the following documents for

A. Approval

- 1.
- 2.
- 3.

B. Review

- 1.
- 2.
- 3.

Appendix 8. Functional Guarantees

1. General

This Appendix sets out

- (a) the functional guarantees referred to in GCC Clause 28 (Functional Guarantees)
- (b) the preconditions to the validity of the functional guarantees, either in production and/or consumption, set forth below
- (c) the minimum level of the functional guarantees
- (d) the formula for calculation of liquidated damages for failure to attain the functional guarantees.

2. Preconditions

The Contractor gives the functional guarantees (specified herein) for the facilities, subject to the following preconditions being fully satisfied:

[List any conditions for the carrying out of the Guarantee Test referred to in GCC Sub-Clause 25.2.]

3. Functional Guarantees

Subject to compliance with the foregoing preconditions, the Contractor guarantees as follows:

3.1 Production Capacity

*[List here the production capacity that the Contractor is to guarantee, **making sure to use, as functional guarantees, the figures offered by the Contractor in its bid.**]*

and/or

3.2 Raw Materials and Utilities Consumption

*[List here the guaranteed items of consumption per unit of production (e.g., kg, tons, kcal, kWh, etc.) that the Contractor is to guarantee, **making sure to use, as functional guarantees, the figures offered by the Contractor in its bid.**]*

4. Failure in Guarantees and Liquidated Damages

4.1 Failure to Attain Guaranteed Production Capacity

If the production capacity of the facilities attained in the guarantee test, pursuant to GCC Sub-Clause 25.2, is less than the guaranteed figure specified in para. 3.1 above, but the actual production capacity attained in the guarantee test is not less than the minimum level specified in para. 4.3 below, and the Contractor elects to pay liquidated damages to the Employer in lieu of making changes, modifications and/or additions to the Facilities, pursuant to GCC Sub-Clause 28.3, then the Contractor shall pay liquidated damages at the rate of *[amount in the contract currency]* for every complete one percent (1%) of the deficiency in the production capacity of the Facilities, or at a proportionately reduced rate for any deficiency, or part thereof, of less than a complete one percent (1%).

4.2 Raw Materials and Utilities Consumption in Excess of Guaranteed Level

[To be specified in the appropriate wording for the type of facilities if there are consumption guarantees.]

If the actual measured figure of specified raw materials and utilities consumed per unit (or their average total cost of consumption) exceeds the guaranteed figure specified in para. 3.2 above (or their specified average total cost of consumption), but the actual consumption attained in the guarantee test, pursuant to GCC Sub-Clause 25.2, is not more than the maximum level specified in para. 4.3 below, and the Contractor elects to pay liquidated damages to the Employer in lieu of making changes, modifications and/or additions to the Facilities pursuant to GCC Sub-Clause 28.3, then the Contractor shall pay liquidated damages at the rate of *[amount in the contract currency]* for every complete one percent (1%) of the excess consumption of the Facilities, or part thereof, of less than a complete one percent (1%).

[The rate of liquidated damages specified in paras. 4.1 and 4.2 above shall be at least equivalent to the rate specified in the Bid Data Sheet under ITB Sub-Clause 25.3 (d), in Single Stage bidding, or ITB Sub-Clause 35.3 (c), in Two Stage bidding, for the comparison of functional guarantees provided by the bidders.]

4.3 Minimum Levels

Notwithstanding the provisions of this paragraph, if as a result of the guarantee test(s), the following minimum levels of performance guarantees (and consumption guarantees) are not attained by the Contractor, the Contractor shall at its own cost make good any deficiencies until the Facilities reach any of such minimum performance levels, pursuant to GCC Sub-Clause 28.2:

- (a) production capacity of the Facilities attained in the guarantee test: ninety-five percent (95%) of the guaranteed production capacity

and/or

- (b) average total cost of consumption of all the raw materials and utilities of the Facilities: one hundred and five percent (105%) of the guaranteed figures.

4.4 Limitation of Liability

Subject to para. 4.3 above, the Contractor's aggregate liability to pay liquidated damages for failure to attain the functional guarantees shall not exceed _____ percent (___ %) of the Contract price [*the percentage specified shall not exceed ten percent (10%)*].

4. Performance Security Forms²

4.1 Bank Guarantee

_____ [Bank's Name, and Address of Issuing Branch or Office]

Beneficiary: [Name and Address of Employer]

Date: _____

PERFORMANCE GUARANTEE No.: _____

We have been informed that [name of Contractor] (hereinafter called "the Contractor") has entered into Contract No. [reference number of the contract] dated _____ with you, for the execution of [name of contract and brief description of Facilities] (hereinafter called "the Contract").

Furthermore, we understand that, according to the conditions of the Contract, a performance guarantee is required.

At the request of the Contractor, we [name of Bank] hereby irrevocably undertake to pay you any sum or sums not exceeding in total an amount of [amount in figures] (____) [amount in words]³, upon receipt by us of your first demand in writing accompanied by a written statement stating that the Contractor is in breach of its obligation(s) under the Contract, without your needing to prove or to show grounds for your demand or the sum specified therein.

This guarantee shall be reduced by half upon our receipt of:

- (a) a copy of the Operational Acceptance Certificate; or
- (b) a registered letter from the Contractor (i) attaching a copy of its notice requesting issuance of the Operational Acceptance Certificate and (ii) stating that the project manager has failed to issue such Certificate within the time required or provide in writing justifiable reasons why such Certificate has not been issued, so that Operational Acceptance is deemed to have occurred.

This guarantee shall expire no later than the earlier of:⁴

² The Employer should insert either the Bank Guarantee (4.1) or the Conditional Guarantee (4.2).

³ The Guarantor shall insert an amount representing the percentage of the Contract Price specified in the Contract and denominated either in the currency(ies) of the Contract or a freely convertible currency acceptable to the Employer.

⁴ This text shall be revised as and where necessary to take into account (i) partial acceptance of the Facilities in accordance with Sub-Clause 25.4 of the GCC; and (ii) extension of the performance security when the Contractor is liable for an extended warranty obligation pursuant to Sub-Clause 27.10 of the GCC (although in this latter case the Employer might want to consider an extended warranty security in lieu of the extension of the performance security).

- (a) twelve months after our receipt of either (a) or (b) above; or
- (b) eighteen months after our receipt of:
 - (i) a copy of the Completion Certificate; or
 - (ii) a registered letter from the Contractor, attaching a copy of the notice to the project manager that the Facilities are ready for commissioning, and stating that fourteen days have elapsed from receipt of such notice (or seven days have elapsed if the notice was a repeated notice) and the project manager has failed to issue a Completion Certificate or inform the Contractor in writing of any defects or deficiencies; or
 - (iii) a registered letter from the Contractor stating that no Completion Certificate has been issued but the Employer is making use of the Facilities; or
- (c) the ____ day of _____, 2____.⁵

Consequently, any demand for payment under this guarantee must be received by us at this office on or before that date.

This guarantee is subject to the Uniform Rules for Demand Guarantees, ICC Publication No. 458, except that subparagraph (ii) of Sub-article 20(a) is hereby excluded.

[signature(s)]

⁵ Insert the date twenty-eight days after the expected expiration date of the Defect Liability Period. The Employer should note that in the event of an extension of the time for completion of the Contract, the Employer would need to request an extension of this guarantee from the Guarantor. Such request must be in writing and must be made prior to the expiration date established in the guarantee. In preparing this guarantee, the Employer might consider adding the following text to the form, at the end of the penultimate paragraph: “The Guarantor agrees to a one-time extension of this guarantee for a period not to exceed [six months][one year], in response to the Employer’s written request for such extension, such request to be presented to the Guarantor before the expiry of the guarantee.”

4.2 Bank Guarantee—Conditional

Date: _____
 Loan/Credit N^o: _____
 IFB N^o: _____

[Name of Contract]

To: *[Name and address of Employer]*

Dear Ladies and/or Gentlemen,

We refer to the Contract Agreement (“the Contract”) signed on *[date]* between you and *[name of Contractor]* (“the Contractor”) concerning design, execution and completion of *[Brief description of the Facilities]*.

By this letter we, the undersigned, *[name of Bank]*, a Bank (or company) organized under the laws of *[country of Bank]* and having its registered/principal office at *[address of Bank]*, do hereby jointly and severally with the Contractor irrevocably guarantee payment owed to you by the Contractor, pursuant to the Contract, up to the sum of *[amount]*, equivalent to *[number]* percent (___%) *[amount shall not exceed ten percent (10%) in any case]* of the Contract Price until the date of the Operational Acceptance Certificate and thereafter up to a sum of *[amount]*, equivalent to *[number]* percent (___%) *[amount shall not exceed five percent (5%) in any case]* of the Contract Price, until twelve (12) months after the date of Operational Acceptance, or eighteen (18) months after Completion of the Facilities, whichever comes first.

Where it is agreed between you and the Contractor that the Facilities are to be accepted in parts, and thus where there are separate Completion and Operational Acceptance Certificates for each part, this Letter of Guarantee shall be apportioned to the value of each such part and shall reduce or expire as provided above on or following Completion or Operational Acceptance of each part.

We shall only undertake to make payment under this Letter of Guarantee upon our receipt of a written demand signed by your duly authorized officer for a specified sum, where such demand sets out the reasons for your claim under this Letter of Guarantee and is accompanied by

- (a) a copy of the written notice sent by you to the Contractor before making the claim under this Guarantee, specifying the Contractor’s breach of contract and requesting the Contractor to remedy it
- (b) a letter signed by your duly authorized officer certifying that the Contractor has failed to remedy the default within the period allowed for remedial action

- (c) a copy of your written notice to the Contractor stating your intent to claim under this Letter of Guarantee because of the Contractor's failure to remedy the default in accordance with the request referred to in para. (a) above.

Our liability under this Letter of Guarantee shall be to pay to you whichever is the lesser of the sum so requested or the amount then guaranteed hereunder in respect of any demand duly made hereunder prior to expiry of this Letter of Guarantee, without being entitled to inquire whether or not this payment is lawfully demanded.

This Letter of Guarantee shall be valid from the date of issue until the earlier of twelve (12) months after the date of Operational Acceptance or eighteen (18) months after the date of Completion of the Facilities or, where the Facilities are to be accepted in parts, twelve (12) months after the date of Operational Acceptance or eighteen (18) months after the date of Completion of the last part or *[date]*, whichever comes first.

Except for the documents herein specified, no other documents or other action shall be required, notwithstanding any applicable law or regulation.

If the Defect Liability Period is extended with respect to any part of the Facilities in accordance with the Contract, you shall notify us, and the validity of this Letter of Guarantee shall be extended with respect to the percentage of the Contract Price stipulated in the notification until expiry of such extended Defect Liability Period.

Our liability under this Letter of Guarantee shall become null and void immediately upon its expiry, whether it is returned or not, and no claim may be made hereunder after such expiry or after the aggregate of the sums paid by us to you shall equal the sums guaranteed hereunder, whichever is the earlier.

All notices to be given hereunder shall be given by registered (airmail) post to the addressee at the address herein set out or as otherwise advised by and between the parties hereto.

We hereby agree that any part of the Contract may be amended, renewed, extended, modified, compromised, released or discharged by mutual agreement between you and the Contractor, and this security may be exchanged or surrendered without in any way impairing or affecting our liabilities hereunder without notice to us and without the necessity for any additional endorsement, consent or guarantee by us, provided, however, that the sum guaranteed shall not be increased or decreased.

No action, event or condition which by any applicable law should operate to discharge us from liability hereunder shall have any effect and we hereby waive any right we may have to apply such law, so that in all respects our liability hereunder shall be irrevocable and, except as stated herein, unconditional in all respects.

Yours truly,
[Name of the Bank]

Authorized Signature

5. Bank Guarantee Form for Advance Payment

[Bank's Name, and Address of Issuing Branch or Office]

Beneficiary: *[Name and Address of Employer]*

Date: _____

ADVANCE PAYMENT GUARANTEE No.: _____

We have been informed that *[name of Contractor]* (hereinafter called "the Contractor") has entered into Contract No. *[reference number of the contract]* dated *[date]* with you, for the execution of *[name of contract and brief description of Facilities]* (hereinafter called "the Contract").

Furthermore, we understand that, according to the conditions of the Contract, an advance payment in the sum *[amount in figures]* (____) *[amount in words]* is to be made against an advance payment guarantee.

At the request of the Contractor, we *[name of Bank]* hereby irrevocably undertake to pay you any sum or sums not exceeding in total an amount of *[amount in figures]* (____) *[amount in words]* upon receipt by us of your first demand in writing accompanied by a written statement stating that the Contractor is in breach of its obligation under the Contract because the Contractor used the advance payment for purposes other than toward the execution of the Works.

It is a condition for any claim and payment under this guarantee to be made that the advance payment referred to above must have been received by the Contractor on his account number _____ at *[name and address of Bank]*.

The maximum amount of this guarantee shall be progressively reduced in proportion to the value of each part-shipment or part-delivery of plant and equipment to the site, as indicated in copies of the relevant shipping and delivery documents that shall be presented to us. This guarantee shall expire, at the latest, upon our receipt of documentation indicating full repayment by the Contractor of the amount of the advance payment, or on the ___ day of _____, 2___, whichever is earlier.⁶ Consequently, any demand for payment under this guarantee must be received by us at this office on or before that date.

⁶ Insert the expected expiration date of the Time for Completion. The Employer should note that in the event of an extension of the time for completion of the Contract, the Employer would need to request an extension of this guarantee from the Guarantor. Such request must be in writing and must be made prior to the expiration date established in the guarantee. In preparing this guarantee, the Employer might consider adding the following text to the form, at the end of the penultimate paragraph: "The Guarantor agrees to a one-time extension of this guarantee for a period not to exceed [six months][one year], in response to the Employer's written request for such extension, such request to be presented to the Guarantor before the expiry of the guarantee."

This guarantee is subject to the Uniform Rules for Demand Guarantees, ICC Publication No. 458.

[signature(s)]

6. Form of Completion Certificate

Date: _____
Loan/Credit N^o: _____
IFB N^o: _____

[Name of Contract]

To: *[Name and address of Contractor]*

Dear Ladies and/or Gentlemen,

Pursuant to GCC Clause 24 (Completion of the Facilities) of the General Conditions of the Contract entered into between yourselves and the Employer dated *[date]*, relating to the *[brief description of the Facilities]*, we hereby notify you that the following part(s) of the Facilities was (were) complete on the date specified below, and that, in accordance with the terms of the Contract, the Employer hereby takes over the said part(s) of the Facilities, together with the responsibility for care and custody and the risk of loss thereof on the date mentioned below.

1. Description of the Facilities or part thereof: *[description]*
2. Date of Completion: *[date]*

However, you are required to complete the outstanding items listed in the attachment hereto as soon as practicable.

This letter does not relieve you of your obligation to complete the execution of the Facilities in accordance with the Contract nor of your obligations during the Defect Liability Period.

Very truly yours,

Title
(Project Manager)

7. Form of Operational Acceptance Certificate

Date: _____
Loan/Credit N^o: _____
IFB N^o: _____

[Name of Contract]

To: *[Name and address of Contractor]*

Dear Ladies and/or Gentlemen,

Pursuant to GCC Sub-Clause 25.3 (Operational Acceptance) of the General Conditions of the Contract entered into between yourselves and the Employer dated *[date]*, relating to the *[brief description of the Facilities]*, we hereby notify you that the Functional Guarantees of the following part(s) of the Facilities were satisfactorily attained on the date specified below.

1. Description of the Facilities or part thereof: *[description]*
2. Date of Operational Acceptance: *[date]*

This letter does not relieve you of your obligation to complete the execution of the Facilities in accordance with the Contract nor of your obligations during the Defect Liability Period.

Very truly yours,

Title
(Project Manager)

8. Change Order Procedures

Date: _____
Loan/Credit N^o: _____
IFB N^o: _____

CONTENTS

1. General
2. Change Order Log
3. References for Changes

ANNEXES

- Annex 1 Request for Change Proposal
- Annex 2 Estimate for Change Proposal
- Annex 3 Acceptance of Estimate
- Annex 4 Change Proposal
- Annex 5 Change Order
- Annex 6 Pending Agreement Change Order
- Annex 7 Application for Change Proposal

Change Order Procedure

1. General

This section provides samples of procedures and forms for implementing changes in the Facilities during the performance of the Contract in accordance with GCC Clause 39 (Change in the Facilities) of the General Conditions of Contract.

2. Change Order Log

The Contractor shall keep an up-to-date Change Order Log to show the current status of Requests for Change and Changes authorized or pending, as Annex 8. Entries of the Changes in the Change Order Log shall be made to ensure that the log is up-to-date. The Contractor shall attach a copy of the current Change Order Log in the monthly progress report to be submitted to the Employer.

3. References for Changes

- (1) Request for Change as referred to in GCC Clause 39 shall be serially numbered CR-X-nnn.
- (2) Estimate for Change Proposal as referred to in GCC Clause 39 shall be serially numbered CN-X-nnn.
- (3) Acceptance of Estimate as referred to in GCC Clause 39 shall be serially numbered CA-X-nnn.
- (4) Change Proposal as referred to in GCC Clause 39 shall be serially numbered CP-X-nnn.
- (5) Change Order as referred to in GCC Clause 39 shall be serially numbered CO-X-nnn.

Note: (a) Requests for Change issued from the Employer's Home Office and the Site representatives of the Employer shall have the following respective references:

| | |
|-------------|----------|
| Home Office | CR-H-nnn |
| Site | CR-S-nnn |

- (b) The above number "nnn" is the same for Request for Change, Estimate for Change Proposal, Acceptance of Estimate, Change Proposal and Change Order.

Annex 1. Request for Change Proposal

(Employer's Letterhead)

To: *[Contractor's name and address]*

Date: _____

Attention: *[Name and title]*

Contract Name: *[Contract name]*

Contract Number: *[Contract number]*

Dear Ladies and/or Gentlemen:

With reference to the captioned Contract, you are requested to prepare and submit a Change Proposal for the Change noted below in accordance with the following instructions within *[number]* days of the date of this letter *[or on or before (date)]*.

1. Title of Change: *[Title]*
2. Change Request No./Rev.: *[Number]*
3. Originator of Change: Employer: *[Name]*
Contractor (by Application for Change Proposal No. *[Number]*)⁷:
4. Brief Description of Change: *[Description]*
5. Facilities and/or Item No. of equipment related to the requested Change: *[Description]*
6. Reference drawings and/or technical documents for the request of Change:

| <u>Drawing No./Document No.</u> | <u>Description</u> |
|---------------------------------|--------------------|
| | |
7. Detailed conditions or special requirements on the requested Change: *[Description]*
8. General Terms and Conditions:
 - (a) Please submit your estimate to us showing what effect the requested Change will have on the Contract Price.
 - (b) Your estimate shall include your claim for the additional time, if any, for completion of the requested Change.

⁷ Refer to Annex 7.

- (c) If you have any opinion negative to the adoption of the requested Change in connection with the conformability to the other provisions of the Contract or the safety of the Plant or Facilities, please inform us of your opinion in your proposal of revised provisions.
- (d) Any increase or decrease in the work of the Contractor relating to the services of its personnel shall be calculated.
- (e) You shall not proceed with the execution of the work for the requested Change until we have accepted and confirmed the amount and nature in writing.

(Employer's Name)

(Signature)

(Name of signatory)

(Title of signatory)

Annex 2. Estimate for Change Proposal

(Contractor's Letterhead)

To: *[Employer's name and address]*

Date: _____

Attention: *[Name and title]*

Contract Name: *[Contract name]*

Contract Number: *[Contract number]*

Dear Ladies and/or Gentlemen:

With reference to your Request for Change Proposal, we are pleased to notify you of the approximate cost of preparing the below-referenced Change Proposal in accordance with GCC Sub-Clause 39.2.1 of the General Conditions of Contract. We acknowledge that your agreement to the cost of preparing the Change Proposal, in accordance with GCC Sub-Clause 39.2.2, is required before estimating the cost for change work.

1. Title of Change: *[Title]*
2. Change Request No./Rev.: *[Number]*
3. Brief Description of Change: *[Description]*
4. Scheduled Impact of Change: *[Description]*
5. Cost for Preparation of Change Proposal: *[Cost]*⁸

| (a) Engineering | (Amount) |
|--|----------|
| (i) Engineer _____ hrs x _____ rate/hr = | _____ |
| (ii) Draftsperson _____ hrs x _____ rate/hr = | _____ |
| Sub-total _____ hrs | _____ |
| Total Engineering Cost | _____ |
| (b) Other Cost | _____ |
| Total Cost (a) + (b) | _____ |

⁸ Costs shall be in the currencies of the Contract.

(Contractor's Name)

(Signature)

(Name of signatory)

(Title of signatory)

Annex 3. Acceptance of Estimate

(Employer's Letterhead)

To: *[Contractor's name and address]*

Date: _____

Attention: *[Name and title]*Contract Name: *[Contract name]*Contract Number: *[Contract number]*

Dear Ladies and/or Gentlemen:

We hereby accept your Estimate for Change Proposal and agree that you should proceed with the preparation of the Change Proposal.

1. Title of Change: *[Title]*
2. Change Request No./Rev.: *[Request number/revision]*
3. Estimate for Change Proposal No./Rev.: *[Proposal number/revision]*
4. Acceptance of Estimate No./Rev.: *[Estimate number/revision]*
5. Brief Description of Change: *[Description]*
6. Other Terms and Conditions: In the event that we decide not to order the Change accepted, you shall be entitled to compensation for the cost of preparation of Change Proposal described in your Estimate for Change Proposal mentioned in para. 3 above in accordance with GCC Clause 39 of the General Conditions of Contract.

(Employer's Name)_____
(Signature)_____
(Name and Title of signatory)

Annex 4. Change Proposal

(Contractor's Letterhead)

To: *[Employer's name and address]*

Date: _____

Attention: *[Name and title]*Contract Name: *[Contract name]*Contract Number: *[Contract number]*

Dear Ladies and/or Gentlemen:

In response to your Request for Change Proposal No. *[Number]*, we hereby submit our proposal as follows:

1. Title of Change: *[Name]*
2. Change Proposal No./Rev.: *[Proposal number/revision]*
3. Originator of Change: Employer: *[Name]*
Contractor: *[Name]*
4. Brief Description of Change: *[Description]*
5. Reasons for Change: *[Reason]*
6. Facilities and/or Item No. of Equipment related to the requested Change: *[Facilities]*
7. Reference drawings and/or technical documents for the requested Change:

| <u>Drawing/Document No.</u> | <u>Description</u> |
|-----------------------------|--------------------|
|-----------------------------|--------------------|

8. Estimate of increase/decrease to the Contract Price resulting from Change Proposal:⁹

(Amount)

- | | |
|----------------------------------|--|
| (a) Direct material | |
| (b) Major construction equipment | |

⁹ Costs shall be in the currencies of the Contract.

- (c) Direct field labor (Total _____ hrs) _____
- (d) Subcontracts _____
- (e) Indirect material and labor _____
- (f) Site supervision _____
- (g) Head office technical staff salaries

| | | |
|--------------------|---------------------------|-------|
| Process engineer | _____ hrs @ _____ rate/hr | _____ |
| Project engineer | _____ hrs @ _____ rate/hr | _____ |
| Equipment engineer | _____ hrs @ _____ rate/hr | _____ |
| Procurement | _____ hrs @ _____ rate/hr | _____ |
| Draftsperson | _____ hrs @ _____ rate/hr | _____ |
| Total | _____ hrs | _____ |

- (h) Extraordinary costs (computer, travel, etc.) _____
- (i) Fee for general administration, _____ % of Items _____
- (j) Taxes and customs duties _____

Total lump sum cost of Change Proposal _____
[Sum of items (a) to (j)]

Cost to prepare Estimate for Change Proposal _____
[Amount payable if Change is not accepted]

- 9. Additional time for Completion required due to Change Proposal
- 10. Effect on the Functional Guarantees
- 11. Effect on the other terms and conditions of the Contract
- 12. Validity of this Proposal: within *[Number]* days after receipt of this Proposal by the Employer
- 13. Other terms and conditions of this Change Proposal:
 - (a) You are requested to notify us of your acceptance, comments or rejection of this detailed Change Proposal within *[Number]* days from your receipt of this Proposal.
 - (b) The amount of any increase and/or decrease shall be taken into account in the adjustment of the Contract Price.

- (c) Contractor's cost for preparation of this Change Proposal:²

(Note) *This cost shall be reimbursed by the Employer in case of Employer's withdrawal or rejection of this Change Proposal without default of the Contractor in accordance with GCC Clause 39 of the General Conditions of Contract.*

(Contractor's Name)

(Signature)

(Name of signatory)

(Title of signatory)

² Specify where necessary.

Annex 5. Change Order

(Employer's Letterhead)

To: *[Contractor's name and address]*

Date: _____

Attention: *[Name and title]*Contract Name: *[Contract name]*Contract Number: *[Contract number]*

Dear Ladies and/or Gentlemen:

We approve the Change Order for the work specified in the Change Proposal (No. *[Number]*), and agree to adjust the Contract Price, Time for Completion and/or other conditions of the Contract in accordance with GCC Clause 39 of the General Conditions of Contract.

1. Title of Change: *[Name]*
2. Change Request No./Rev.: *[Request number/revision]*
3. Change Order No./Rev.: *[Order number/revision]*
4. Originator of Change: Employer: *[Name]*
Contractor: *[Name]*
5. Authorized Price:

Ref. No.: *[Number]*Date: *[Date]*Foreign currency portion *[Amount]* plus Local currency portion *[Amount]*

6. Adjustment of Time for Completion

None

Increase *[Number]* daysDecrease *[Number]* days

7. Other effects, if any

Authorized by: _____
(Employer)

Date: _____

Accepted by: _____
(Contractor)

Date: _____

Annex 6. Pending Agreement Change Order

(Employer's Letterhead)

To: *[Contractor's name and address]*

Date: _____

Attention: *[Name and title]*Contract Name: *[Contract name]*Contract Number: *[Contract number]*

Dear Ladies and/or Gentlemen:

We instruct you to carry out the work in the Change Order detailed below in accordance with GCC Clause 39 of the General Conditions of Contract.

1. Title of Change: *[Name]*
2. Employer's Request for Change Proposal No./Rev.: *[Number/revision]* dated: *[Date]*
3. Contractor's Change Proposal No./Rev.: *[Number/revision]* dated: *[Date]*
4. Brief Description of Change: *[Description]*
5. Facilities and/or Item No. of equipment related to the requested Change: *[Facilities]*
6. Reference Drawings and/or technical documents for the requested Change:

| <u>Drawing/Document No.</u> | <u>Description</u> |
|-----------------------------|--------------------|
|-----------------------------|--------------------|

7. Adjustment of Time for Completion:
8. Other change in the Contract terms:
9. Other terms and conditions:

(Employer's Name)

(Signature)

(Name of signatory)

(Title of signatory)

Annex 7. Application for Change Proposal

(Contractor's Letterhead)

To: *[Employer's name and address]*

Date: _____

Attention: *[Name and title]*Contract Name: *[Contract name]*Contract Number: *[Contract number]*

Dear Ladies and/or Gentlemen:

We hereby propose that the below-mentioned work be treated as a Change in the Facilities.

1. Title of Change: *[Name]*
2. Application for Change Proposal No./Rev.: *[Number/revision]* dated: *[Date]*
3. Brief Description of Change: *[Description]*
4. Reasons for Change:
5. Order of Magnitude Estimation (in the currencies of the Contract):
6. Scheduled Impact of Change:
7. Effect on Functional Guarantees, if any:
8. Appendix:

(Contractor's Name)_____
(Signature)_____
(Name of signatory)

(Title of signatory)