



Udaipur Smart City Limited

**National Competitive Bidding (Single stage two parts)
for**

**Development of Parking Lot under Smart City
Mission, Udaipur**

BID No: USCL/ E - 8 /2017-18

July, 2017

**Chief Executive Officer
Udaipur Smart City Limited, Udaipur**

Bidding Document

Table of Contents

Notice Inviting Bids

Section-I : Instructions to Bidders

Section-II : Bid Data Sheet

Section-III : Evaluation and Qualification Criteria

Section-IV : Bidding Forms

Section-V : Procuring Entity's Requirements

Section-VIA: General Conditions of Contract

Section-VIB : Special Conditions of the Contract/ Contract Data

Section-VIC : Contract Forms



UDAIPUR SMART CITY LIMITED

Telephone: 0294-2421255, Email: mc_udaipur@rediffmail.com

DETAILED NOTICE INVITING BID (NIB)

NIT No: E-8 / 2017-18

Udaipur Smart City Limited invites online unconditional tenders under Single Stage two envelope system are invited through e-procurement portal <http://eproc.rajasthan.gov.in> from eligible bidders as per criteria mentioned in bid document, for **Development of Parking Facility at Gulab Bagh, Udaipur** for Udaipur Smart City Limited.

Name & Address of the Procuring Entity	Name: Mr. Sidharth Sihag, Chief Executive Officer Address: Udaipur Smart City Limited, Udaipur
Subject Matter of Procurement	Development of Parking Lot under Smart City Mission, Udaipur
Period of completion of physical works	12 months
Bid Procedure	Single-stage: Two Part (envelope) open competitive eBid procedure at http://eproc.rajasthan.gov.in
Selection Method	Least Cost based selection
Eligibility Criteria	As detailed in bid documents
Websites for downloading Bidding Document	sppp.rajasthan.gov.in eproc.rajasthan.gov.in
Fees	RFQ document fee: Rs. 20,000 (Rupees Twenty Thousand only) in Demand Draft in favour of "Chief Executive Officer, Udaipur Smart City Limited" payable at Udaipur, Rajasthan or shall be deposited through RTGS/ NEFT in the account of Udaipur Smart City Limited having account number 004994600000301 with Yes Bank Limited, Ground & First Floor, "Goverdhan plaza" 29 N N Acharya Marg, payable at Udaipur, Rajasthan (IFSC Code YESB0CMSNOC) RISL Processing Fee: Rs. 1000 (Rupees one

	thousand only) in BC/Demand Draft in favour of "Managing Director, RISL" payable at "Jaipur" or shall be deposited through RTGS/ NEFT in the account of Udaipur Smart City Limited having account number 004994600000301 with Yes Bank Limited, Ground & First Floor, "Goverdhan plaza" 29 N N Acharya Marg, payable at Udaipur, Rajasthan (IFSC Code YESB0CMSNOC)
Bid Security and Mode of Payment	Amount: Rs. 15,80,000/- Mode of Payment: Banker's Cheque/Demand Draft drawn on any Scheduled Commercial Bank or Bank Guarantee as per Bid document.
Period of on-line availability of Bidding Documents (Start / End Date)	From: 29-7-2017, 11.00 AM onwards till 04:00 PM of 1-09-2017
Pre-bid Meeting	Date/ Time 11-8-2017 at 11:00 AM Place: Udaipur Smart City Limited, Udaipur
Manner, End Date for submission of Bids	Manner: Online at e-Proc website http://eproc.rajasthan.gov.in End Date: 01-09-2017 (up to 04:00 P.M.)
Submission of original Banker's Cheque/ Demand Draft for Bid Document cost, Bid Security, Bid Processing Fee & other documents listed herein after	04-09-2017 till 03:00 PM
Date & Time of Technical Bid Opening	Date: 04-09-2017 Time: 04:00 PM
Date/ Time/ Place of Financial Bid Opening	Will be intimated later to the Technically qualified bidders
Bid Validity	180 days from the bid submission deadline
Note:	
1) Bidders (authorised signatory) shall submit their offer on-line in Electronic formats both for technical and financial proposal. However, DD / Banker's Cheques / BG (if applicable) for RFP Document Fees, RISL Processing Fees and Bid Security should be submitted physically in original at the office of Udaipur Smart City Limited, Udaipur by time and date mentioned above as prescribed in bid document and scanned copy of same should also be	

- uploaded along with the technical Bid/ cover.
- 2) In addition to above, the following original documents should also be submitted physically in the Udaipur Smart City Limited, Udaipur office by time and date mentioned above and scanned copies of same should also be uploaded along with the technical Bid/ cover:
 - i. Letter of Technical Bid
 - ii. Power of Attorney for appointing authorized representative
 - iii. Joint Venture Agreement (if applicable)
 - iv. Proof of Registration in AA class as required
 - 3) Any subsequent addendum/corrigendum shall be published only at the websites www.sppp.raj.nic.in & <http://eproc.rajasthan.gov.in> and will not be published in newspapers. In case there is a holiday on the day of opening of bids, activities assigned on that date shall be carried out on the next working day.
 - 4) Before electronically submitting the bids, it should be ensured that all the bid documents including conditions of contract are digitally signed by the bidder.
 - 5) Department will not be responsible for delay in online submission due to any reason. For this, bidders are requested to upload the complete bid well advance in time so as to avoid 11th hour issues like slow speed; choking of web site due to heavy load or any other unforeseen problems.
 - 6) All the prospective bidders are encouraged to participate in the pre-bid meeting and it is advised that the work sites are visited and bid documents are studied thoroughly.
 - 7) The procuring entity reserves the sole right to cancel the bid process and reject any or all of the Bids without assigning any reason.
 - 8) Procurement entity disclaims any factual/ or other errors in the bidding document (the onus is purely on the individual bidders to verify such information) and the information provided therein are intended only to help the bidders to prepare a logical bid-proposal.
 - 9) No conditional bids shall be accepted and such bids shall be summarily rejected forthwith.
 - 10) The provisions of RTPP Act 2012 and Rules 2013 thereto shall be applicable for this procurement. Furthermore, in case of any inconsistency in any of the provisions of this bidding document with the RTPP Act 2012 and Rules thereto, the latter shall prevail.

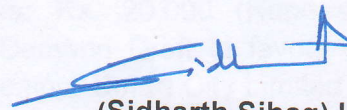

(Sidharth Sihag) IAS
Chief Executive Officer
Udaipur Smart City Limited,
Udaipur

Section-I: Instructions to Bidders

INSTRUCTION TO BIDDERS

Important Instruction:- The Law relating to procurement “The Rajasthan Transparency in Public Procurement Act, 2012” [hereinafter called the Act] and the “Rajasthan Public Procurement Rules, 2012” [hereinafter called the Rules] under the said Act have come into force which are available on the website of State Public Procurement Portal <http://sppp.raj.nic.in>. Therefore, the Bidders are advised to acquaint themselves with the provisions of the Act and the Rules before participating in the Bidding process. If there is any discrepancy between the provisions of the Act and the Rules and this Bidding Document, the provisions of the Law shall prevail.

1. General			
1.1	Scope of Bid	1.1.1	In support of the Invitation to Bid indicated in the Bid Data Sheet (BDS), the Procuring Entity as indicated in the BDS, issues this Bidding Document for the procurement of works as named in the BDS and as specified in Section V, Procuring Entity's Requirements.
1.2	Interpretation	1.2.1	Throughout this Bidding Document: the term “in writing” means communicated in written form through letter, fax, e-mail etc. with proof of receipt. if the context so requires, singular means plural and vice versa; and “Day” means calendar day
1.3	Code of Integrity	1.3.1	Any person participating in the procurement process shall,- i. not offer any bribe, reward or gift or any material benefit either directly or indirectly in exchange for an unfair advantage in procurement process or to otherwise influence the procurement process; ii. not misrepresent or omit that misleads or attempts to mislead so as to obtain a financial or other benefit or avoid an obligation; iii. not indulge in any collusion, bid rigging or anti-competitive behavior to impair the transparency, fairness and progress of the procurement process; iv. not misuse any information shared between the Procuring Entity and the Bidders with an intent to gain unfair advantage in the procurement process; v. not indulge in any coercion including impairing or harming or threatening to do the same, directly or indirectly, to any party or to its property to influence the procurement process; vi. not obstruct any investigation or audit of a procurement process; vii. disclose conflict of interest, if any; and

			viii. disclose any previous transgressions with any Entity in India or any other country during the last three years or any debarment by any other Procuring Entity.
		1.3.2	<p>Conflict of Interest: A conflict of interest is considered to be a situation in which a party has interests that could improperly influence that party's performance of official duties or responsibilities, contractual obligations, or compliance with applicable laws and regulations.</p> <p>A Bidder may be considered to be in conflict of interest with one or more parties in this bidding process if, including but not limited to:</p> <ul style="list-style-type: none"> i. have controlling partners/ shareholders in common; or ii. receive or have received any direct or in direct subsidy from any of them ;or iii. have the same legal representative for purposes of this Bid; or iv. have a relationship with each other, directly or through common third parties, that puts them in a position to have access to information about or influence on the Bid of another Bidder, or influence the decisions of the Procuring Entity regarding this bidding process; or v. the Bidder participates in more than one Bid in this bidding process. Participation by a Bidder in more than one Bid will result in the disqualification of all Bids in which the Bidder is involved. However, this does not limit the inclusion of the same subcontractor, not otherwise participating as a Bidder, in more than one Bid; or vi. the Bidder or any of its affiliates participated as a consultant in the preparation of the design or technical specifications of the Works that are the subject of the Bid; or vii. the Bidder or any of its affiliates has been hired (or is proposed to be hired) by the Procuring Entity as Engineer-in-charge/ consultant for the Contract.
		1.3.3	The Bidder shall have to give a declaration regarding compliance of the Code of Integrity prescribed in the Act, the Rules and stated above in this Clause along with its Bid, in the format specified in Section IV, Bidding Forms.

		1.3.4	Breach of Code of Integrity by the Bidder:- Without prejudice to the provisions of Chapter IV of the Rajasthan Transparency in Public Procurement Act, in case of any breach of the Code of Integrity by a Bidder or prospective Bidder, as the case may be, the Procuring Entity may take appropriate action in accordance with the provisions of sub-section (3) of section 11 and section 46 of the Act.
1.4	Eligible Bidders	1.4.1	A Bidder may be a natural person, private Entity, government-owned Entity or, where permitted in the Bidding documents, any combination of them with a formal intent to enter into an agreement or under an existing agreement in the form of a Joint Venture [JV], Consortium or Association. In the case of a Joint Venture, Consortium or Association:- all parties to the Joint Venture, Consortium or Association shall sign the Bid and they shall be jointly and severally liable; and a Joint Venture, Consortium or Association shall nominate a representative who shall have the authority to conduct all business for and on behalf of any and all the parties of the Joint Venture, Consortium or Association during the Bidding process. In the event the Bid of Joint Venture, Consortium or Association is accepted, either they shall form a registered Joint Venture, Consortium or Association as company/firm or otherwise all the parties to Joint Venture, Consortium or Association shall sign the Agreement.
		1.4.2	A Bidder, and all parties constituting the Bidder, shall have the nationality of India. In case of International Competitive Bidding or Joint Venture, Consortium or Association [where permitted], the nationality of the Bidder and all parties constituting the Bidder shall be of India or an eligible country declared as such by Government of India. A Bidder shall be deemed to have nationality of a country if the Bidder is a citizen or constituted or incorporated, and operates in conformity with the provisions of the Laws of that country. This criterion shall also apply to the determination of the nationality of proposed Sub-Contractors or suppliers for any part of the Contract including related services.
		1.4.3	A Bidder should not have a conflict of interest in the procurement in question as stated in the Rule 81 and this Bidding document.

		1.4.4	A Bidder debarred under section 46 of the Act shall not be eligible to participate in any procurement process undertaken by any Procuring Entity, if debarred by the State Government; and a Procuring Entity, if debarred by such Procuring Entity.
		1.4.5	The Bidder must be a registered Contractor in appropriate class with the Department/ Organization. He shall furnish necessary proof for the same. PSU can be participate in tender without registration.
		1.4.6	<p>i Any change in the constitution of the firm, etc., shall be notified forth with by the Bidder in writing to the Procuring Entity and such change shall not relieve any former partner/ member of the firm, etc from any liability under the Contract.</p> <p>ii No new partner/partners shall be accepted in the firm by the Bidder in respect of the contract unless he/they agree to abide by all its terms, conditions and deposit with the Procuring Entity a written agreement to this effect. The Bidder's receipt for acknowledgement or that of any partners subsequently accepted as above shall bind all of them and will be sufficient discharge for any of the purpose of the Contract.</p> <p>iii The status of the lead partner/ representative of the Joint Venture, Consortium or Association as a major stake holder shall not change without the consent of the Procuring Entity. New major stakeholder must agree to abide by all terms and conditions of the Contract.</p>
		1.4.7	Bidders shall provide such evidence of their continued eligibility satisfactory to the Procuring Entity, should the Procuring Entity request.
		1.4.8	In case a prequalification or empanelment or registration process has been conducted prior to the bidding process, this bidding shall be open only to the pre-qualified, empanelled or registered Bidders.
		1.4.9	Each Bidder shall submit only one Bid except in case of alternative bids, if permitted.
		1.4.10	Bidder must have GST registration. all taxes shall be applicable as per law. He is also required to provide proof of Permanent Account Number (PAN) given by Income Tax Department.
2. Contents of Bidding Document			

2.1	Sections of the Bidding Document	2.1.1	<p>The Bidding Document consists of Parts I, II and III, which include all the Sections indicated below, and should be read in conjunction with any Addenda issued in accordance with ITB Clause 2.3 [Amendment of Bidding Document].</p> <p>Part I: Bidding Procedures Section I. Instructions to Bidders (ITB) Section II. Bid Data Sheet (BDS) Section III. Evaluation and Qualification Criteria Section IV. Bidding Forms</p> <p>Part II: Requirements Section V. Procuring Entity's Requirements.</p> <p>Part III: Contract Section VI A. General Conditions of Contract [GCC] Section VI B. Special Conditions of Contract [SCC] Section VI C. Contract Forms</p>
		2.1.2	The Invitation for Bids (NIB) issued by the Procuring Entity is also part of the Bidding Document.
		2.1.3	i. The Bidding Document shall be uploaded on the e-procurement portal, eproc.rajsthan.gov.in along with the Notice Inviting Bids. The complete Bidding Document shall also be placed on the State Public Procurement Portal, sppp.rajsthan.gov.in . The prospective Bidders may download the bidding document from these portals. The price of the Bidding Document and processing fee of e-bid shall have to be paid to the Procuring Entity in the amount and manner as specified in Bid Data Sheet and e-procurement portal.
		2.1.4	The Procuring Entity is not responsible for the completeness of the Bidding Document and its addenda, if they were not downloaded correctly from the e-procurement portal or the State Public Procurement Portal.
		2.1.5	The Bidder is expected to examine all instructions, forms, terms and specifications in the Bidding Document. Failure to furnish all information or authentic documentation required by the Bidding Document may result in the rejection of the Bid.
2.2	Clarification of Bidding Document and Pre-Bid Conference	2.2.1	The Bidder shall be deemed to have carefully examined the conditions, specifications, size, make and drawings, etc. of the Works and Related Services to be provided. If any Bidder has any doubts as to the meaning of any portion of the conditions or of the specifications, drawings etc., it shall, before submitting the Bid, refer the same to the Procuring

			Entity and get clarifications. A Bidder requiring any clarification of the Bidding Document shall contact the Procuring Entity in writing or e-mail at the Procuring Entity's address indicated in the BDS. The Procuring Entity will respond in writing or e-mail to any request for clarification, within seven days provided that such request is received no later than twenty-one (21) days prior to the deadline for submission of Bids as specified in ITB Sub-Clause 4.2.1 [Deadline for Submission of Bids]. The clarification issued, including a description of the inquiry but without identifying its source shall also be placed on the State Public Procurement Portal and should the Procuring Entity deem it necessary to amend the Bidding Document as a result of a clarification, it shall do so following the procedure under ITB Clause 2.3 [Amendment of Bidding Document] through an addendum which shall form part of the Bidding Document.
		2.2.2	The Bidder or his authorized representative is invited to attend the Pre- Bid Conference, if provided for in the BDS. The purpose of the Pre- Bid Conference will be to clarify issues and to answer questions on any matter related to this procurement that may be raised at that stage. If required, a conducted site visit may be arranged by the Procuring Entity.
		2.2.3	The Bidder is requested, to submit questions in writing, to reach the Procuring Entity not later than one week before the date of Pre-Bid Conference.
		2.2.4	Minutes of the Pre-Bid Conference, including the text of the questions raised, and the responses given, without identifying the source, will be transmitted promptly to all Bidders who attended the Pre-Bid Conference and shall also be placed on the State Public Procurement Portal and the e-procurement portal. Any modification to the Bidding Document that may become necessary as a result of the Pre-Bid Conference shall be made by the Procuring Entity exclusively through the issue of an addendum (part of Bid document) and not through the minutes of the Pre-Bid Conference.
		2.2.5	At any time prior to the deadline for submission of the Bids, the Procuring Entity, suo motto, may also amend the Bidding Document, if required, by issuing an addenda which will form part of the Bidding Document.

		2.2.6	Non-attendance at the Pre-Bid Conference will not be a cause for disqualification of a Bidder.
2.3	Amendment of Bidding Document	2.3.1	Any addendum issued shall be part of the Bidding Document and shall be uploaded on the State Public Procurement Portal and the e-procurement portal.
		2.3.2	To give prospective Bidders reasonable time in which to take an addendum into account in preparing their Bids, the Procuring Entity may, at its discretion, extend the deadline for the submission of the Bids, pursuant to ITB Sub-Clause 4.2 [Deadline for Submission of Bids], under due publication on the State Public Procurement Portal and the e-procurement portal and newspapers.
3. Preparation of Bids			
3.1	Cost of Bidding	3.1.1	The Bidder shall bear all costs associated with the preparation and submission of its Bid, and the Procuring Entity shall not be responsible or liable for those costs, regardless of the conduct or outcome of the bidding process.
		3.1.2	The Bidder shall furnish the scanned attested copies of following documents with its Bid:- <ul style="list-style-type: none"> i. Partnership Deed and valid registration certificate with the Registrar of Firms in case of Partnership Firms. Power of Attorney in favour of the partner signing/submitting the Bid, authorizing him to represent all partners of the firm. ii. VAT/ Sales Tax registration certificate and VAT/Sales Tax clearance certificate from the concerned Commercial Taxes Officer and Permanent Account Number (PAN) given by the Income Tax Department. iii. Address of residence and office, telephone numbers e-mail address in case of sole Proprietorship. iv. Certificate of Registration and Memorandum of Association issued by Registrar of Companies in case of a registered company and in case of any other statutory or registered body, certificate of incorporation or registration issued by concerned authorities. Power of attorney in favour of the person signing the Bid. v. Where permitted to bid as Joint Venture, Consortium or Association, letter of formal intent to enter in to an agreement or an existing agreement in the form of a Joint Venture,

			Consortium or Association.
3.2	Language of Bid	3.2.1	The Bid, as well as all correspondence and documents relating to the Bid exchanged by the Bidder and the Procuring Entity, shall be written in English/ Hindi or a language specified in the BDS. Supporting documents and printed literature that are part of the Bid may be in another language provided they are accompanied by an accurate translation of the relevant passages duly accepted by the Bidder in English/ Hindi or the language specified in the BDS, in which case, for purposes of interpretation of the Bid, such translation shall govern.
3.3	Documents Comprising the Bid	3.3.1	The Bid shall comprise of two covers, one containing the Technical Bid/ Proposal and the other the Financial or Price Bid/ Proposal. One more cover containing scanned copies of proof of payment in form specified in Bid Data Sheet, of the price of Bidding Document, processing fee and Bid Security/ Bid Securing Declaration shall be enclosed separately.
		3.3.2	The Technical Bid/ Proposal shall contain the following : i. Technical Bid/ Proposal Submission Sheet and Technical Bid containing the filled up Bidding Forms and Declarations related to Technical Bid and Code of Integrity given in Section IV [Bidding Forms]; ii. proof of payment of price of Bidding Document, processing fee, Bid Security, in accordance with ITB Clause 3.10; iii. written confirmation authorizing the signatory of the Bid to commit the Bidder, in accordance with ITB Clause 3.11; iv. documentary evidence in accordance with ITB Clause 3.7 establishing the Bidder's eligibility to bid; v. documentary evidence in accordance with ITB Clause 3.8 establishing the Bidder's qualifications to perform the contract if its Bid is accepted; vi. Drawings/ designs in support of the Works to be executed; vii. the Notice Inviting Bids; viii. any other document required in the BDS; and ix. others considered necessary to strengthen the Bid submitted.

		3.3.3	The Financial Bid/ Price Proposal shall contain the following : Financial Bid and the applicable Price Schedules, in accordance with ITB Clauses 3.4, 3.5; Any other document required in the BDS.
3.4	Bid Submission Sheets and Price Schedules	3.4.1	The Bidder shall submit the Technical Bid and Financial Bid using the Bid Submission Sheets provided in Section IV [Bidding Forms]. These forms must be completed without any alterations to their format, and no substitutes shall be accepted. All blank spaces shall be filled in with the information requested.
		3.4.2	The Bidder shall submit as part of the Financial Bid, the Price Schedules for Works, using the forms provided in Section IV [Bidding Forms].
3.5	Bid Prices	3.5.1	<p>i. In case of Item Rate Contracts, the Bidder shall fill in rates and prices for all items of the Works described in the Bill of Quantities. Items against which no rate or price is entered by the Bidder will not be paid for by the Procuring Entity but will have to be executed and shall be deemed covered by the rates for other items and prices in the Bill of Quantities.</p> <p>ii. In case of Percentage Rate Contracts, combined single percentage above or below must be quoted by the Bidder for all items of the Bill of Quantities.</p> <p>iii. In case of Lump Sum Contracts, only Total Price which the Bidder wants to charge for the entire Works with all its contingencies in accordance with drawings and specifications shall be quoted by the Bidder. A Schedule of Rates shall be specified in the Bid Data Sheet in order to regulate the amount to be added to or deducted from the fixed sum on account of additions and alterations not covered by the Contract. Payments shall be linked to various stages of completion of the Works specified in Activity Schedule given in Bid Data Sheet.</p>
		3.5.2	Prices quoted by the Bidder shall be fixed during the Bidder's Performance of the Contract and not subject to variation on any account, unless otherwise specified in the BDS. A Bid submitted with an adjustable price quotation shall be treated as non-responsive and shall be rejected, pursuant to ITB Clause 5.7 [Responsiveness of Bids]. However, if in accordance with the BDS, prices quoted by the Bidder shall be subject to adjustment during the

			performance of the Contract, a Bid submitted with a fixed price quotation shall not be rejected, but the adjustment shall be treated as zero.
		3.5.3	All duties, taxes and other levies payable by the Bidder under the contract, or for any other cause, shall be included in the rates and prices, and the total Bid Price submitted by the Bidder.
3.6	Currencies of Bid.	3.6.1	The unit rates and the prices shall be quoted by the Bidder entirely in Indian Rupees unless otherwise specified in BDS. All payments shall be made in Indian Rupees only, unless otherwise specified in the BDS.
3.7	Documents Establishing the Eligibility of the Bidder	3.7.1	To establish their eligibility in accordance with ITB Clause 1.4 [Eligible Bidders], Bidders shall: complete the eligibility declarations in the Bid Submission Sheet and Declaration Form included in Section IV [Bidding Forms]; if the Bidder is an existing or intended Joint Venture [JV], Consortium or Association in accordance with ITB Sub-Clause 1.4.1, shall submit a copy of the Agreement, or a letter of intent to enter into such Agreement. The respective document shall be signed by all legally authorized signatories of all the parties to the existing or intended JV, Consortium or Association as appropriate; and the existing or intended JV shall authorize an individual/ partner in one of the firms as lead partner of the JV to act and commit all the partners of JV for the Bid.
3.8	Documents Establishing the Qualifications of the Bidder	3.8.1	To establish its qualifications to perform the Contract, the Bidder shall submit as part of its Technical Proposal the documentary evidence indicated for each qualification criteria specified in Section III, [Evaluation and Qualification Criteria].
3.9	Period of Validity of Bids	3.9.1	Bids shall remain valid for 180 days or the period specified in the BDS after the Bid submission deadline date as specified by the Procuring Entity. A Bid valid for a shorter period shall be rejected by the Procuring Entity as non-responsive.
		3.9.2	In exceptional circumstances, prior to the expiration of the Bid validity period, the Procuring Entity may request Bidders to extend the period of validity of their Bids. The request and the responses shall be made in writing. The Bid Security or a Bid Securing Declaration in accordance with ITB Clause 3.10 [Bid Security] shall also be got extended for thirty days beyond the dead line of the extended validity period.

			A Bidder may refuse the request without forfeiting its Bid Security or a Bid Securing Declaration. A Bidder granting the request shall not be permitted to modify its Bid.
3.10	Bid Security	3.10.1	Unless otherwise specified in the BDS, the Bidder shall furnish as part of its Bid, a Bid Security for the amount specified in the BDS.
		3.10.2	Bid Security shall be 2% of the value of the Works indicated in the NIB. The bid security shall be in Indian Rupees, if not otherwise specified in the BDS.
		3.10.3	The Bid Security may be given in the form of a banker's Cheque or demand draft or bank guarantee of a Scheduled Bank in India, in specified format, or deposited through eGRAS/ net banking, if permitted.
		3.10.4	In lieu of Bid Security, a Bid Securing Declaration shall be taken from Government Departments and State Government Public Sector Enterprises, Autonomous bodies, Registered Societies, Cooperative Societies which are owned or controlled or managed by the State Government, Public Sector Enterprises of Central Government. For the Bid Securing Declaration the Bidder shall use the form included in Section IV [Bidding Forms].
		3.10.5	Scanned copy of Bid Security instrument or a Bid Securing Declaration shall necessarily accompany the sealed Bid. Any Bid not accompanied by Bid Security or Bid Securing Declaration, if not exempted, shall be liable to be rejected.
		3.10.6	Bid Security of a Bidder lying with the Procuring Entity in respect of other Bids awaiting decision shall not be adjusted towards Bid Security for the this Bid. The Bid Security originally deposited may, however be taken into consideration in case Bids are re-invited.
		3.10.7	The issuer of the Bid Security and the confirmer, if any, of the Bid Security, as well as the form and terms of the Bid Security, must be acceptable to the Procuring Entity.
		3.10.8	Prior to submitting its Bid, a Bidder may request the Procuring Entity to confirm the acceptability of a proposed issuer of a Bid Security or of a proposed confirmer, if different than as specified in ITB Clause 3.10.3. The Procuring Entity shall respond promptly to such a request.

		3.10.9	The bank guarantee presented as Bid Security shall be got confirmed from the concerned issuing bank. However, the confirmation of the acceptability of a proposed issuer or of any proposed confirmer does not preclude the Procuring Entity from rejecting the Bid Security on the ground that the issuer or the confirmer, as the case may be, has become insolvent or is under liquidation or has otherwise ceased to be creditworthy.
		3.10.10	The Bid Security of unsuccessful Bidders shall be refunded soon after final acceptance of successful Bid and signing of Contract Agreement and submitting Performance Security by successful Bidder pursuant to ITB Clause 6.4 [Performance Security].
		3.10.11	The Bid Security taken from a Bidder shall be forfeited in the following cases, namely:- i. when the Bidder withdraws or modifies his Bid after opening of Bids; or ii. when the Bidder does not execute the agreement in accordance with ITB Clause 6.3 [Signing of Contract] after issue of letter of acceptance/ placement of Work order within the specified time period; or iii. when the Bidder fails to commence the Works as per Work Order within the time specified; or iv. when the Bidder does not deposit the Performance Security in accordance with ITB Clause 6.4 [Performance Security]; in the prescribed time limit after the work order is placed; v. if the Bidder breaches any provision of the Code of Integrity prescribed for Bidders in the Act and Chapter VI of the Rules or as specified in ITB Clause 1.3 [Code of Integrity]; or vi. if the Bidder does not accept the correction of its Bid Price pursuant to ITB Sub-Clause 5.5 [Correction of Arithmetical Errors].
		3.10.12	In case of the successful bidder, the amount of Bid Security may be adjusted in arriving at the amount of the Performance Security, or refunded if the successful bidder furnishes the full amount of Performance Security. No interest will be paid by the Procuring Entity on the amount of Bid Security.

		3.10.13	The Procuring Entity shall promptly refund the Bid Security of the Bidders at the earliest of any of the following events, namely:- i. the expiry of validity of Bid Security; ii. the execution of agreement for procurement and Performance Security is furnished by the successful bidder; iii. the cancellation of the procurement process; or iv. the withdrawal of Bid prior to the deadline for presenting Bids, unless the Bidding Document stipulates that no such withdrawal is permitted.
		3.10.14	The Bid Security of a Joint Venture, Consortium or Association must be in the name of the Joint Venture, Consortium or Association that submits the Bid. If the Joint Venture, Consortium or Association has not been legally constituted at the time of Bidding, the members of the proposed consortium or JV shall enter in to an Agreement to form a legally constituted JV after the issue of Letter of Acceptance / Letter of Intent to them and also declare a partner as the lead partner in whose name the Bid Security may be submitted.
3.1 1	Format and Signing of Bid	3.11.1	All pages of the Technical and Financial Bid shall be digitally signed by the Bidder or authorized signatory on behalf of the Bidder. This authorization shall consist of a written confirmation as specified in the BDS and shall be attached to the Bid. In case of a Joint Venture, Consortium or Association, if the Joint Venture, Consortium or Association has not been legally constituted at the time of Bidding, all the members of the proposed Joint Venture, Consortium or Association shall digitally sign the Bid.
4. Submission and Opening of Bids			
4. 1	Sealing and Marking of Bids	4.1.1	Bidders shall submit their Bids to the Procuring Entity electronically only on the e-procurement portal, eproc.raj.nic.in. In submission of their Bids, the Bidders should follow the step by step instructions given on the e-procurement portal.
		4.1.2	The Bidder shall enclose the Technical Bid and the Financial Bid in separate covers. The proof of payment of price of Bidding Document, processing fee and Bid Security shall be enclosed in third cover. The price of Bidding Document and Bid Security shall be paid in the name of the Procuring Entity and the

			processing fee shall be paid in the name of RISL.
4.2	Deadline for Submission of Bids	4.2.1	Bids shall be submitted electronically only upto the time and date specified in the Notice Inviting Bids and BDS or an extension issued thereof.
4.3	Withdrawal, Substitution and Modification of Bids	4.3.1	A Bidder may withdraw, substitute or modify its Bid after it has been submitted by submitting electronically on the e-procurement portal a written Withdrawal/ Substitutions/ Modifications etc. Notice on the e-procurement portal, duly digitally signed by the Bidder or his authorized representative, and shall include a copy of the authorization in accordance with ITB Sub-Clause 3.11.1 [Format and Signing of Bid]. The corresponding Withdrawal, Substitution or Modification of the Bid must accompany the respective written Notice. All Notices must be received by the Procuring Entity on the e-procurement portal prior to the deadline specified for submission of Bids in accordance with ITB Sub-Clause 4.2. [Deadline for Submission of Bids].
		4.3.2	No Bid shall be withdrawn, substituted or modified in the interval between the deadline for submission of the Bid and the expiration of the period of Bid validity specified in ITB Clause 3.9.[Period of Validity of Bids] or any extension thereof.
4.4	Bid Opening	4.4.1	The electronic Technical Bids shall be opened by the Bids opening committee constituted by the Procuring Entity at the time, date and place specified in the Bid Data Sheet in the presence of the Bidders or their authorized representatives, who choose to be present.
		4.4.2	The Bids opening committee may co-opt experienced persons in the committee to conduct the process of Bid opening.
		4.4.3	The Bidders may choose to witness the electronic Bid opening procedure online.
		4.4.4	The Financial Bids shall be kept unopened until the time of opening of the Financial Bids. The date, time, and location of electronic opening of the Financial Bids shall be intimated to the bidders who are found qualified by the Procuring Entity in evaluation of their Technical Bids.

		4.4.5	<p>The Bids opening committee shall prepare a list of the Bidders or their representatives attending the opening of Bids and obtain their signatures on the same. The list shall also contain the representative's name and telephone number and corresponding Bidders' names and addresses. The authority letters brought by the representatives shall be attached to the list. The list shall be signed by all the members of Bids opening committee with date and time of opening of the Bids.</p>
		4.4.6	<p>First, covers marked as "WITHDRAWAL" shall be opened, read out, and recorded and the covers containing the corresponding Technical Bids and Financial Bids shall not be opened. No Bid shall be permitted to be withdrawn unless the corresponding withdrawal notice contains a valid authorization to request the withdrawal and is readout and recorded at Bid opening. If the withdrawal notice is not accompanied by the valid authorization, the withdrawal shall not be permitted and the corresponding Technical Bid shall be opened.</p> <p>Next, covers marked as "SUBSTITUTION Technical Bid" shall be opened, read out, recorded. The covers containing the Substitution Technical Bids and/ or Substitution Financial Bids shall be exchanged for the corresponding covers being substituted. Only the Substitution Technical Bids shall be opened, read out, and recorded. Substitution Financial Bids will remain unopened in accordance with ITB Sub-Clause 4.4.4. No Bid shall be substituted unless the corresponding substitution notice contains a valid authorisation to request the substitution and is read out and recorded at Bid opening.</p> <p>Covers marked as "MODIFICATION Technical Bid" shall be opened thereafter, read out and recorded with the corresponding Technical Bids. No Technical Bid and/ or Financial Bid shall be modified unless the corresponding modification notice contains a valid authorization to request the modification and is read out and recorded at opening of Technical Bids. Only the Technical Bids, both Original as well as Modification, are to be opened, read out, and recorded at the opening. Financial Bids, both Original as well as Modification, will remain unopened in accordance with ITB Sub-Clause 4.4.4.</p>

		4.4.7	<p>All other covers containing the Technical Bids shall be opened one at a time and the following read out and recorded-</p> <ul style="list-style-type: none"> i. the name of the Bidder; ii. whether there is a modification or substitution; iii. whether proof of payment of Bid Security or Bid Securing Declaration, if required, payment of price of the Bidding Document and processing fee have been enclosed; iv. any other details as the Bids opening committee may consider appropriate. <p>After all the Bids have been opened, their hard copies shall be printed and shall be initialed and dated on the first page and other important papers of each Bid by the members of the Bids opening committee.</p>
		4.4.8	<p>Only Technical Bids shall be read out and recorded at the bid opening and shall be considered for evaluation. No Bid shall be rejected at the time of opening of Technical Bids except Alternative Bids (if not permitted) and Bids not accompanied with the proof of payment of the required price of Bidding Document, processing fee and Bid Security.</p>
		4.4.9	<p>The Bids opening committee shall prepare a record of opening of Technical Bids that shall include, as a minimum: the name of the Bidder and whether there is a withdrawal, substitution, modification, or alternative offer (if they were permitted), any conditions put by Bidder and the presence or absence of the price of Bidding Document, processing fee and Bid Security. The Bidders or their representatives, who are present, shall sign the record. The members of the Bids opening committee shall also sign the record with date.</p>
		4.4.10	<p>After completion of the evaluation of the Technical Bids, the Procuring Entity shall invite Bidders who have submitted substantially responsive Technical Bids and who have been determined as being qualified to attend the electronic opening of the Financial Bids. The date, time, and location of the opening of Financial Bids will be intimated in writing by the Procuring Entity. Bidders shall be given reasonable notice of the opening of Financial Bids.</p>
		4.4.11	<p>The Procuring Entity shall notify Bidders in writing whose Technical Bids have been rejected on the grounds of being substantially non-responsive and not qualified in accordance with the requirements of</p>

			the Bidding Document.
		4.4.12	The Bids opening committee shall conduct the electronic opening of Financial Bids of all Bidders who submitted substantially responsive Technical Bids and have qualified in evaluation of Technical Bids, in the presence of Bidders or their representatives who choose to be present at the address, date and time specified by the Procuring Entity.
		4.4.13	<p>All covers containing the Financial Bids shall be opened one at a time and the following read out and recorded-</p> <ol style="list-style-type: none"> i. the name of the Bidder; ii. whether there is a modification or substitution; iii. the Bid Prices; iv. any other details as the Bids opening committee may consider appropriate. <p>After all the Bids have been opened, their hard copies shall be printed and shall be initialed and dated on the first page of the each Bid by the members of the Bids opening committee. All the pages of the Price Schedule and letters, Bill of Quantities attached shall be initialed and dated by the members of the committee. Key information such as prices, completion period, etc. shall be encircled and unfilled spaces in the Bids shall be marked and signed with date by the members of the Bids opening committee.</p>
		4.4.14	The Bids opening committee shall prepare a record of opening of Financial Bids that shall include as a minimum: the name of the Bidder and whether there is a withdrawal, substitution, or modification, the Bid Price, any conditions, any discounts and alternative offers (if they were permitted). The Bidders or their representatives, who are present, shall sign the record. The members of the Bids opening committee shall also sign the record with date.
5. Evaluation and Comparison of Bids			
5.1	Confidentiality	5.1.1	Information relating to the examination, evaluation, comparison, and post-qualification of Bids, and recommendation of contract award, shall not be disclosed to Bidders or any other persons not officially concerned with such process until information on Contract award is communicated to all Bidders.

		5.1.2	Any attempt by a Bidder to influence the Procuring Entity in its examination of qualification, evaluation, comparison of the Bids or Contract award decisions may resulting in the rejection of its Bid, in addition to the legal action which may be taken by the Procuring Entity under the Act and the Rules.
		5.1.3	Notwithstanding ITB Sub-Clause 5.1.2 [Confidentiality], from the time of opening the Bid to the time of Contract award, if any Bidder wishes to contact the Procuring Entity on any matter related to the Bidding process, it shall do so in writing.
		5.1.4	In addition to the restrictions specified in section 49 of the Act, the Procuring Entity, while procuring a subject matter of such nature which requires the procuring Entity to maintain confidentiality, may impose condition for protecting confidentiality of such information.
5.2	Clarification of Technical or Financial Bids	5.2.1	To assist in the examination, evaluation, comparison and qualification of the Technical or Financial Bids, the Bid evaluation committee may, at its discretion, ask any Bidder for a clarification regarding his Bid. The committee's request for clarification and the response of the Bidder shall be in writing.
		5.2.2	Any clarification submitted by a Bidder with regard to his Bid that is not in response to a request by the Bid evaluation committee shall not be considered.
		5.2.3	No change in the prices or substance of the Bid shall be sought, offered, or permitted, except to confirm the correction of arithmetical errors discovered by the Bid evaluation committee in the evaluation of the financial Bids.
		5.2.4	No substantive change to qualification information or to a submission, including changes aimed at making an unqualified Bidder, qualified or an unresponsive submission, responsive shall be sought, offered or permitted.
5.3	Deviations, Reservations and Omissions in Technical or Financial Bids	5.3.1	During the evaluation of Technical or Financial Bids, the following definitions apply: i. "Deviation" is a departure from the requirements specified in the Bidding Document; ii. "Reservation" is the setting of limiting conditions or withholding from complete acceptance of the requirements specified in the Bidding Document; and iii. "Omission" is the failure to submit part or all of the information or documentation required in the Bidding Document.

5.4	Nonmaterial Non conformities in Technical or Financial Bids	5.4.1	Provided that a Technical or Financial Bid is substantially responsive, the Procuring Entity may waive any nonconformities (with recorded reasons) in the Bid that do not constitute a material deviation, reservation or omission.
		5.4.2	Provided that a Technical or Financial Bid is substantially responsive, the Procuring Entity may request the Bidder to submit the necessary information or documentation, within a reasonable period of time, to rectify nonmaterial nonconformities or omissions in the Bid related to documentation requirements. Request for information or documentation on such nonconformities shall not be related to any aspect of the Financial Proposal of the Bid. Failure of the Bidder to comply with the request may result in the rejection of its Bid.
		5.4.3	<p>*Provided that a Technical or Financial Bid is substantially responsive, the Procuring Entity will rectify nonmaterial nonconformities or omissions (with recorded reasons). To this effect, the Bid Price shall be adjusted during evaluation of Financial Proposals for comparison purposes only, to reflect the price of the missing or non- conforming item or component. The adjustment shall be made using the method indicated in Section III, Evaluation and Qualification Criteria.</p> <p>* [This ITB Sub-Clause should be kept only when considered necessary]</p>
5.5	Correction of Arithmetical Errors in Financial Bid	5.5.1	<p>Provided that a Financial Bid is substantially responsive, the Bid evaluation committee shall correct arithmetical errors during evaluation of Financial Bid on the following basis:</p> <ol style="list-style-type: none"> i. if there is a discrepancy between the unit price and the total price that is obtained by multiplying the unit price and quantity, the unit price shall prevail and the total price shall be corrected, unless in the opinion of the Procuring Entity there is an obvious misplacement of the decimal point in the unit price, in which case the total price as quoted shall govern and the unit price shall be corrected; ii. if there is an error in a total corresponding to the addition or subtraction of subtotals, the subtotals shall prevail and the total shall be corrected; and iii. if there is a discrepancy between words and figures, the amount in words shall prevail, unless

			the amount expressed in words is related to an arithmetic error, in which case the amount in figures shall prevail subject to (i) and (ii) above.
		5.5.2	If the Bidder that submitted the lowest evaluated Bid does not accept the correction of errors, its Bid shall be disqualified and its Bid Security shall be forfeited or its Bid Securing Declaration shall be executed.
5.6	Preliminary Examination of Technical or Financial Bids	5.6.1	The Procuring Entity shall examine the Technical or Financial Bids to confirm that all documents and technical documentation requested in ITB Sub-Clause 3.3 [Documents Comprising the Bid] have been provided, and to determine the completeness of each document submitted.
		5.6.2	The Procuring Entity shall confirm, following the opening of the Technical or Financial Bids, that the following documents and information have been provided : <ul style="list-style-type: none"> i. Bid is signed, as per the requirements listed in the Bidding documents; ii. Bid has been sealed as per instructions provided in the Bidding documents; iii. Bid is valid for the period, specified in the Bidding documents; iv. Bid is accompanied by Bid Security or Bid securing declaration; v. Bid is unconditional and the Bidder has agreed to give the required performance Security; vi. Price Schedules in the Financial Bids are in accordance with ITB Clause 3.4 [Bid Submission Sheets and Price Schedules]; vii. written confirmation of authorization to commit the Bidder; viii. Declaration by the Bidder in compliance of Section 7 and 11 of the Act; and ix. other conditions, as specified in the Bidding Document are fulfilled.
5.7	Responsiveness of Technical or Financial Bids	5.7.1	The Procuring Entity's determination of the responsiveness of a Technical or Financial Bid is to be based on the contents of the Bid itself, as defined in ITB Sub-Clause 3.3 [Documents Comprising the Bid].

		5.7.2	<p>A substantially responsive Technical or Financial Bid is one that meets without material deviation, reservation, or omission to all the terms, conditions, and specifications of the Bidding Document. A material deviation, reservation, or omission is one that:</p> <p>(a) if accepted, would-</p> <ol style="list-style-type: none"> i. affect in any substantial way the scope, quality, or performance of the Goods and Related Services specified in Section V, Schedule of Supply; or ii. limits in any substantial way, inconsistent with the Bidding Document ,the Procuring Entity's rights or the Bidder's obligations under the proposed Contract; or <p>(b) if rectified, would unfairly affect the competitive position of other Bidders presenting substantially responsive Bids.</p>
		5.7.3	The Procuring Entity shall examine the technical aspects of the Bid in particular, to confirm that requirements of Section V, Procuring Entity's Requirements have been met without any material deviation, reservation, or omission.
		5.7.4	If a Technical or Financial Bid is not substantially responsive to the Bidding Document, it shall be rejected by the Procuring Entity and may not subsequently be made responsive by the Bidder by correction of the material deviation, reservation, or omission.
5.8	Examination of Terms and Conditions of the Technical or Financial Bids	5.8.1	The Procuring Entity shall examine the Bids to confirm that all terms and conditions specified in the GCC and the SCC have been accepted by the Bidder without any material deviation or reservation.
		5.8.2	The Procuring Entity shall evaluate the technical aspects of the Bid submitted in accordance with ITB Clauses 3.3 [Documents Comprising the Bid] and to confirm that all requirements specified in Section V [Procuring Entity's Requirements] of the Bidding Document and all amendments or changes requested by the Procuring Entity in accordance with ITB Clause 2.3 [Amendment of Bidding Document] have been met without any material deviation or reservation.

5.9	Evaluation of Qualification of Bidders in Technical Bids	5.9.1	The determination of qualification of a Bidder in evaluation of Technical Bids shall be based upon an examination of the documentary evidence of the Bidder's qualifications submitted by the Bidder, pursuant to ITB Clause 3.8 [Documents Establishing the Qualifications of the Bidder] and in accordance with the qualification criteria indicated in Section III [Evaluation and Qualification Criteria]. Factors not included in Section III, shall not be used in the evaluation of the Bidder's qualification.
5.10	Evaluation of Financial Bids	5.10.1	The Procuring Entity shall evaluate each Financial Bid, the corresponding Technical Bid of which has been determined to be substantially responsive
		5.10.2	To evaluate a Financial Bid, the Procuring Entity shall only use all the criteria and methodologies defined in this Clause and in Section III, Evaluation and Qualification Criteria. No other criteria or methodology shall be permitted.
		5.10.3	To evaluate a Financial Bid, the Procuring Entity shall consider the following: <ul style="list-style-type: none"> i. the Bid Price quoted in the Financial Bid; ii. price adjustment for correction of arithmetical errors in accordance with ITB Clause 5.5 [Correction of Arithmetical Errors]; iii. adjustment of bid prices due to rectification of nonmaterial nonconformities or omissions in accordance with ITB Sub Clause 5.4.3 [Nonmaterial Nonconformities in Bids], if applicable.
		5.10.4	If the Bid, which results in the lowest evaluated Bid Price, is considered to be seriously unbalanced, or front loaded, in the opinion of the Procuring Entity, the Procuring Entity may require the Bidder to produce detailed rate analysis for any or all items of the Bill of Quantities, to demonstrate the internal consistency of those rates with the construction methods and schedule proposed. After evaluation of the rate analysis, taking into consideration, the schedule of estimated Contract payments, the Procuring Entity may require that the amount of the Performance security be increased at the cost of the Bidder to a level sufficient to protect the Procuring Entity against financial loss in the event of default of the successful Bidder under the Contract.

5.1 1	Comparison of Bids	5.11.1	The Procuring Entity shall compare all substantially responsive Financial Bids to determine the lowest-evaluated Financial Bid in accordance with ITB Sub-Clause 5.10 [Evaluation of Financial Bids].
5.1 2	Negotiations	5.12.1	To the extent possible, no negotiations shall be conducted after the pre-Bid stage. All clarifications needed to be sought shall be sought in the pre-Bid stage itself.
		5.12.2	Negotiations may, however, be undertaken only with the lowest Bidder under the following circumstances- i. when ring prices have been quoted by the Bidders for the subject matter of procurement; or ii. when the rates quoted vary considerably and considered much higher than the prevailing market rates.
		5.12.3	The Bid evaluation committee shall have full powers to undertake negotiations. Detailed reasons and results of negotiations shall be recorded in the proceedings.
		5.12.4	The lowest Bidder shall be informed about negotiations in writing either through messenger or by registered letter and e-mail (if available). A minimum time of seven days shall be given for calling negotiations. In case of urgency, the Bid evaluation committee, after recording reasons, may reduce the time, provided the lowest Bidder has received the intimation and consented to holding of negotiations.
		5.12.5	Negotiations shall not make the original offer made by the Bidder inoperative. The Bid evaluation committee shall have option to consider the original offer in case the Bidder decides to increase rates originally quoted or imposes any new terms or conditions.
		5.12.6	In case of non-satisfactory achievement of rates from lowest Bidder, the Bid evaluation committee may choose to make a written counter offer to the lowest Bidder and if this is not accepted by him, the committee may decide to reject and re-invite Bids or to make the same counter-offer first to the second lowest Bidder, then to the third lowest Bidder and so on in the order of their initial standing in the bid evaluation and work order be awarded to the Bidder who accepts the counter-offer.
		5.12.7	In case the rates even after the negotiations are considered very high, fresh Bids shall be invited.

5.1 3	Procuring Entity's Right to Accept Any Bid, and to Reject Any or All Bids	5.13.1	The Procuring Entity reserves the right to accept or reject any Bid, and to annul the Bidding process and reject all Bids at any time prior to Contract award without assigning any reasons thereof and without there by incurring any liability to the Bidders.
6. Award of Contract			
6.1	Procuring Entity's Right to Vary Quantities	6.1.1	If the Procuring Entity does not procure any subject matter of procurement or procures less than the quantity specified in the Bidding Document due to change in circumstances, the Bidder shall not be entitled for any claim or compensation except otherwise provided in the Bidding Document.
		6.1.2	Order for additional quantity of an item of the Works up to 50 percent of the original quantity of that item in the Bill of Quantities and for extra items not provided for in the Bill of Quantities may be given but the amount of the additional quantities and extra items, taken together, shall not exceed 50 percent of the Contract Price.
6.2	Acceptance of the successful Bid and award of contract	6.2.1	The Procuring Entity after considering the recommendations of the Bid Evaluation Committee and the conditions of Bid, if any, financial implications, samples, test reports, etc., shall accept or reject the successful Bid.
		6.2.2	Before award of the Contract, the Procuring Entity shall ensure that the price of successful Bid is reasonable and consistent with the required specifications.
		6.2.3	A Bid shall be treated as successful only after the competent authority has approved the procurement in terms of that Bid.
		6.2.4	The Procuring Entity shall award the contract to the Bidder whose offer has been determined to be the lowest in accordance with the evaluation criteria set out in the Bidding Document if the Bidder has been determined to be qualified to perform the contract satisfactorily on the basis of qualification criteria fixed for the Bidders in the Bidding Document for the subject matter of procurement.
		6.2.5	Prior to the expiration of the period of validity of Bid, the Procuring Entity shall inform the successful Bidder in writing, by registered post or email, that its Bid has been accepted.
		6.2.6	If the issuance of formal letter of acceptance (LOA) is likely to take time, in the meanwhile a Letter of

			Intent (LOI) may be sent to the Bidder. The acceptance of an offer is complete as soon as the letter of acceptance or letter of intent is posted and/ or sent by email (if available) to the address of the Bidder given in the Bidding Document.
6.3	Signing of Contract	6.3.1	In the written intimation of acceptance of its Bid sent to the successful Bidder, it shall also be requested to execute an agreement in the format given in the Bidding Document on a non-judicial stamp of requisite value at his cost and deposit the Performance Security or a Performance Security Declaration, if applicable, within a period specified in the BDS or where the period is not specified in the BDS, then within fifteen days from the date on which the LOA or LOI is dispatched to the Bidder. In case the successful bidder is a JV still to be legally constituted, all parties to the JV shall sign the Agreement.
		6.3.2	If the Bidder, whose Bid has been accepted, fails to sign a written procurement contract or fails to furnish the required Performance Security or Performance Security Declaration within the specified time period, the Procuring Entity shall forfeit the Bid Security of the successful bidder / execute the Bid Securing Declaration and take required action against it as per the provisions of the Act and the Rules.
		6.3.3	The Bid Security, if any, of the Bidders whose Bids could not be accepted shall be refunded soon after the contract with the successful Bidder is signed and his Performance Security is obtained. Until a formal contract is executed, LOA or LOI shall constitute a binding contract.
6.4	Performance Security	6.4.1	Performance Security shall be solicited from the successful Bidder except State Govt. Departments and undertakings, corporations, autonomous bodies, registered societies, co-operative societies which are owned or controlled or managed by the State Government and undertakings of Central Government. However, a Performance Security Declaration shall be taken from them. The State Government may relax the provision of Performance Security in particular procurement.

		6.4.2	<p>(i) The amount of Performance Security shall be ten percent, or as specified in the BDS, of the amount of the Work Order. The currency of Performance Security shall be Indian Rupees, if otherwise not specified in BDS.</p> <p>(ii) If the Bid, which results in the lowest evaluated bid price, is seriously unbalanced or front loaded in the opinion of the Procuring Entity, the Procuring Entity may require the Bidder to produce detailed price analysis for any or all items of the Bill of Quantities, to demonstrate the internal consistency of those prices with the construction methods and schedule proposed. After evaluation of the price analysis, taking into consideration the schedule of estimated Contract payments, the Procuring Entity may require that the amount of the performance security be increased (to a maximum of 20% of the bid value of such items) at the expense of the Bidder to a level sufficient to protect the Procuring Entity against financial loss in the event of default of the successful Bidder under the Contract.</p>
		6.4.3	<p>Performance Security shall be furnished in one of the following forms as applicable-</p> <p>(a) Deposit through eGRAS; or</p> <p>(b) Bank Draft or Banker's Cheque of a Scheduled Bank in India; or</p> <p>(c) National Savings Certificates and any other script/ instrument under National Savings Schemes for promotion of small savings issued by a Post Office in Rajasthan, if the same can be pledged under the relevant rules. They shall be accepted at their surrender value at the time of Bid and formally transferred in the name of the Procuring Entity with the approval of Head Post Master; or</p> <p>(d) Bank guarantee. It shall be got verified from the issuing bank. Other conditions regarding bank guarantee shall be same as specified in ITB Sub-Clause 3.10 [Bid Security]; or</p> <p>(e) Fixed Deposit Receipt (FDR) of a Scheduled Bank. It shall be in the name of the Procuring Entity on account of Bidder and discharged by the Bidder in advance. The Procuring Entity shall ensure before accepting the Fixed Deposit Receipt that the Bidder furnishes an undertaking from the bank to make payment/ premature payment of the Fixed Deposit Receipt on demand to the Procuring Entity without</p>

			<p>requirement of consent of the Bidder concerned. In the event of forfeiture of the Performance Security, the Fixed Deposit shall be forfeited along with interest earned on such Fixed Deposit.</p> <p>(f) The successful Bidder at the time of signing of the Contract agreement, may submit option for deduction of Performance Security from his each running and final bill @ 10% of the amount of the bill.</p>
		6.4.4	<p>Performance Security furnished in the form of a document mentioned at options (a) to (e) of Sub-Clause 6.4.3 above, shall remain valid for a period of sixty days beyond the date of completion of all contractual obligations of the Bidder, including operation and / or maintenance and defect liability period, if any.</p>
		6.4.5	<p>Failure of the successful Bidder to submit the above-mentioned Performance Security or sign the Contract shall constitute sufficient grounds for the annulment of the award and forfeiture of the Bid Security. In that event the Procuring Entity may either cancel the procurement process or if deemed appropriate, award the Contract at the rates of the lowest Bidder, to the next lowest evaluated Bidder whose offer is substantially responsive and is determined by the Procuring Entity to be qualified to perform the Contract satisfactorily.</p>
		6.4.6	<p>Forfeiture of Performance Security: Amount of Performance Security in full or part may be forfeited in the following cases:-</p> <ol style="list-style-type: none"> i. when the Bidder does not execute the agreement in accordance with ITB Clause 6.3 [Signing of Contract] within the specified time; after issue of letter of acceptance; or ii. when the Bidder fails to commence the Works as per Work order within the time specified; or iii. when the Bidder fails to complete Contracted Works satisfactorily within the time specified; or iv. when any terms and conditions of the contract is breached; or v. to adjust any established dues against the Bidder from any other contract with the Procuring Entity; or vi. if the Bidder breaches any provision of the Code of Integrity prescribed for the Bidders specified in the Act, Chapter VI of the Rules and this Bidding Document.

			vii. Notice of reasonable time will be given in case of forfeiture of Performance Security. The decision of the Procuring Entity in this regard shall be final.
7. Redressal of Grievances during Procurement Process (Appeals)			
7	Grievance handling procedure during procurement process	7.1	Any grievance of a Bidder pertaining to the procurement process shall be by way of filing an appeal to the First or Second Appellate Authority, as the case may be, as specified in the BDS, in accordance with the provisions of chapter III of the Act and chapter VII of the Rules and as given in Appendix A to these ITB.

Appendix A: Grievance Handling Procedure during Procurement Process (Appeals)

- (1) Filing an appeal.-** If any Bidder or prospective Bidder is aggrieved that any decision, action or omission of the Procuring Entity is in contravention to the provisions of the Act or the Rules or the Guidelines issued there under, he may file an appeal to First or Second Appellate Authority, as the case may be, as may be designated for the purpose, within a period of ten days or such other period as may be specified in the pre-qualification documents, Bidder registration documents or Bidding documents, as the case may be, from the date of such decision or action, omission, as the case may be, clearly giving the specific ground or grounds on which he feels aggrieved:
Provided that after the declaration of a Bidder as successful in terms of section 27 of the Act, the appeal may be filed only by a Bidder who has participated in procurement proceedings:
Provided further that in case a Procuring Entity evaluates the technical Bid before the opening of the financial Bid, an appeal related to the matter of financial Bid may be filed only by a Bidder whose technical Bid is found to be acceptable.
- (2) Appeal not to lie in certain cases. -** No appeal shall lie against any decision of the Procuring Entity relating to the following matters, namely:-
- a) determination of need of procurement;
 - b) provisions limiting participation of Bidders in the Bid process;
 - c) the decision of whether or not to enter into negotiations;
 - d) cancellation of a procurement process;
 - e) applicability of the provisions of confidentiality.
- (3) Form of Appeal.-**
- a) An appeal under sub-section (1) or (4) of section 38 shall be in the annexed Form along with as many copies as there are respondents in the appeal.
 - b) Every appeal shall be accompanied by an order appealed against, if any affidavit verifying the facts stated in the appeal and proof of payment of fee.
 - c) Every appeal may be presented to First Appellate Authority or Second Appellate Authority, as the case may be, in person or through registered post or authorized representative.
- (4) Fee for filing appeal.-**
- a) Fee for first appeal shall be rupees two thousand five hundred and for second appeal shall be rupees ten thousand, which shall be non-refundable.
 - b) The fee shall be paid in the form of bank demand draft or banker's Cheque of a Scheduled Bank payable in the name of Appellate Authority concerned.
- (5) Procedure for disposal of appeals.-**
- a) The First Appellate Authority or Second Appellate Authority, as the case may be, upon filing of appeal, shall issue notice accompanied by copy of appeal, affidavit and documents, if any, to the respondents and fix date of

- hearing.
- b) On the date fixed for hearing, the First Appellate Authority or Second Appellate Authority, as the case may be, shall,-
 - (i) hear all the parties to appeal present before him; and
 - (ii) peruse or inspect documents, relevant records or copies thereof relating to the matter.
 - c) After hearing the parties, perusal or inspection of documents and relevant records or copies thereof relating to the matter, the Appellate Authority concerned shall pass an order in writing and provide the copy of order to the parties to appeal free of cost.
 - d) The order passed under sub-clause (c) above shall be placed on the State Public Procurement Portal.

FORM No. 1
[See rule 83]

Memorandum of Appeal under the Rajasthan Transparency in Public Procurement Act, 2012

Appeal Noof

Before the (First / Second Appellate Authority)

1. Particulars of appellant:

(i) Name of the appellant:

(ii) Official address, if any:

(iii) Residential address:

2. Name and address of the respondent(s):

(1).

(2).

(3).

3. Number and date of the order appealed against and name and designation of the officer / authority who passed the order (enclose copy), or a statement of a decision, action or omission of the Procuring Entity in contravention to the provisions of the Act by which the appellant is aggrieved:

4. If the Appellant proposes to be represented by a representative, the name and postal address of the representative:

5. Number of affidavits and documents enclosed with the appeal:

6. Grounds of appeal:

.....

..... (Supported
by an affidavit)

7. Prayer:

.....

.....

.....

Place

Date.....

Section-II : Bid Data Sheet

SECTION II - BIDDING DATA SHEET (BDS)

The following specific data for the works shall complement, amend, or supplement the provisions in Instructions to Bidders – Section I. Whenever there is a conflict, the provisions herein shall prevail over those in the Instructions to Bidders (ITB).

Instructions to Bidders Clause Reference

A. Introduction

ITB. 1.1.1	The Number of the Invitation for Bids (NIT) is E-8_/ 2017-18 The Procuring Entity is: Udaipur Smart city Limited Representative of the Procuring Entity: Chief Executive Officer, Udaipur Smart city Limited Name of Town: Udaipur Name of the works: Development of Parking Lot under Smart City Mission, Udaipur (Detailed Scope of work has been defined in Section 5.)
	Add the following Clauses;
1.1.2	Period of Completion: The Physical Works shall be completed in its entirety within Twelve (12) months (including mobilization & construction period) to be calculated from the date of issue of the Notice to proceed or such other Start Date as may be specified in the Notice to proceed.
1.1.3	The type of Contract is: Item Rate basis
ITB 1.4.1	Joint Ventures are permitted comprising not more than two 2 (two) firms/companies. The equity under JV of lead firm should be 51% at the minimum and that of other firm should 25% at the minimum.
ITB 1.4.2	“Bidders of any Nationality” are permissible.
ITB 1.4.5	The Bidder / both partners of JV must be a person/ private company/ organization of any State Govt./ Central Govt. / PSU / Govt Autonomous Body / Govt. Undertaking of any country.
ITB 1.4.8	The bidding process is open to bidders who fulfil the eligibility criteria prescribed in section II of this bid document.
ITB 1.4.9	Each bidder shall upload on-line / submit only one bid for one work. A bidder who submits or participates in more than one bid for the particular Work will be disqualified.

B. Bidding Documents

ITB 2.1.3	This is an “on-line tender”. Therefore, tender documents in physical form shall not be available for sale but can be downloaded from the website and pay cost (Rs 20,000/-) while submitting the filled-up Bidding document to the Procuring Entity along with the processing fee of Rs 1000/- separately in favour of RISL, Jaipur The bidder should submit, by date & time specified in bid document, in
-----------	---

	original, hard copies of – (i) cost of bid document as Rs. 20,000/- in the form of DD/Banker's Cheque of a scheduled bank in India or eGRAS in the name of Chief Executive Officer, Udaipur Smart City Limited payable at Udaipur , (ii) Bid processing fee of Rs. 1,000/- in the form of DD in the name of Managing Director, RISL, Udaipur payable at Udaipur , (iii) Bid Security as per RTPP (iv) Letter of Technical Bid, (v) Power of Attorney and (vi) Joint Venture Agreement. The bidder should upload scanned copies of these documents on e-procurement web-site along with their technical bids.
ITB 2.2.1	For Clarification purposes only, the Procuring Entity's address is : Chief Executive Officer, Udaipur Smart city Limited. EMAIL: mc_udaipur@rediffmail.com
ITB 2.2.2	A Pre-Bid conference will take place at the Meeting Hall of, Chief Executive Officer, Udaipur Smart city Limited on 11-8-2017 at 11:00 AM. Bidder is advised to visit the site at his own expenses and if any support is required, the SE/EE shall be contacted.
ITB 2.2.3	The Bidder is requested, to submit questions in writing, to reach the Procuring Entity preferably not later than one week before the Pre- Bid Conference. However, Department may also consider questions / queries raised in writing only, during the pre-bid conference.
ITB 2.3.1	Any addendum issued shall be part of the Bidding Document and shall be uploaded on the State Public Procurement Portal http://sppp.rajasthan.gov.in and the state e-procurement portal http://eproc.rajasthan.gov.in
ITB 2.3.2	To give prospective Bidders reasonable time in which to take an addendum into account in preparing their Bids, the Procuring Entity may, at its discretion, extend the deadline for the submission of the Bids, pursuant to ITB Sub-Clause 4.2 [Deadline for Submission of Bids], under due intimation to the Bidders by uploading it on the State Public Procurement Portal and its e-procurement portal

C. Preparation of Bids

ITB 3.2.1	The language of the bid shall be: English
ITB 3.3.1	The on-line Bid shall comprise of two envelopes submitted simultaneously, one containing the Technical Bid and the other the Financial or Price Bid.
ITB 3.3.2	The Bidder shall submit the forms, declarations and documents, as specified in section IV of Bid Document, with the Technical Bid, in addition to the documents already mentioned in ITB 3.3.2
ITB 3.3.3	The Bidder shall upload the following documents with its Financial Bid: a) Financial Proposal Submission Sheet b) Preamble to BoQ c) And other details, as deemed necessary by the bidder.

ITB 3.5.1	Add following: i. The type of Contract is on Item Rate only
ITB 3.5.2	The Prices quoted by the Bidder shall be fixed
ITB 3.5.3	All variations in taxes and duties shall be borne by the contractor.
ITB 3.9.1	The Bid validity period shall be 180 (One hundred and eight days) days from deadline for submission of bids.
ITB 3.10.2	Add following: Bid security shall be Rs. 15,80,000/- (Rs. Fifteen Lacs Eighty Thousands only)for bidders
ITB 3.10.3	A Bid Security shall be provided as a part of the bid in the form of a banker's Cheque or demand draft or bank guarantee of a Scheduled Bank in India, in specified format which shall remain valid for a period of 30 (thirty) days beyond the validity of the bid.
ITB 3.11.1	The written confirmation of authorization to sign on behalf of the Bidder shall consist of: Power of Attorney and only Digital signed copy shall be submitted through e-procurement website.

D. Submission and Opening of Bids

ITB 4.1.1	<p>For bid submission purposes only, the Procuring Entity's address is : Chief Executive Officer, Udaipur Smart city Limited EMAIL: mc_udaipur@rediffmail.com Bidders shall submit their Bids electronically only.</p> <p>The Bidders shall submit the Bid online with all pages numbered serially and by giving an index of submissions. Each page of the submission shall be initialled by the Authorised Representative of the Bidder as per the terms of the tender. The Bidder shall be responsible for documents accuracy and correctness as per the version uploaded by the Procuring Entity and shall ensure that there are no changes caused in the content of the downloaded document. The bidder shall submit the same document offline till the prescribed time in NIT. The bidder shall follow the following instructions for online submission:</p> <p>i Bidder who wants to participate in bidding will have to procure digital certificate as per IT Act to sign their electronic bids. Offers which are not digitally signed will not be accepted. Bidder shall submit their offer in electronic format on above mentioned website after digitally signing the same.</p> <p>ii Cost of bid document is Rs.20,000/- per tender should be deposited by Non Refundable Demand Draft drawn in favor of Chief Executive Officer, Udaipur Smart City Limited, Udaipur payable at Udaipur, whereas the Processing fee Rs. 1000/- should be deposited by Non Refundable</p>
-----------	--

	<p>Demand Draft drawn in favour of MD, RISL, Jaipur payable at Jaipur. Original documents along with above mentioned fees and other documents as per bid conditions, has to be deposited upto date and time provided in this RFP.</p> <p>iii The Procuring Entity will not be responsible for any mistake occurred at the time of uploading of bid or thereafter.</p> <p>iv If holiday is declared on submission & opening date of tender the scheduled activity will take place on next working day.</p> <p>Bids are required to be submitted in Electronic Format, it shall be submitted on the e-procurement portal : http://eproc.rajasthan.gov.in</p>
ITB 4.2.1	<p>The Deadline for electronic Bid submission is Date: 01-09-2017 Time: 4.00 PM</p>
ITB 4.4.7	<p>The on-line Bid opening shall take place at: The office of Chief Executive Officer, Udaipur Smart city Limited. EMAIL: mc_udaipur@rediffmail.com</p>
4.5.5	<p>The tendering process shall be conducted on-line only; DD/BC tender fee, processing fee and Bid Security shall be submitted physically up to deadline described in tender document.</p>
ITB 4.5.14, 4.5.15	<p>The Procuring Entity will open the Financial proposal as per e-tendering procedure.</p>

E. Award of Contract

ITB 5.11.1	<p>The Bidder quoting the least cost to USCL would be selected for the assignment.</p>
ITB 6.3.1	<p>The period within which the Performance Security is to be submitted by the successful Bidder and the Contract Agreement is to be signed by him from the date of issue of Letter of Acceptance is 30 Days.</p>
ITB 6.3.3	<p>The procuring entity shall promptly return the bid security after the earliest of the following events, namely:</p> <ol style="list-style-type: none"> 1. The expiry of validity of bid security 2. The execution of agreement for procurement and performance security is furnished by the successful bidder; 3. The cancellation of the procurement process; or 4. The withdrawal of bid prior to the deadline for presenting bids, unless the bidding documents stipulate that no such withdrawal is permitted.
As per ITB 6.4.2, 6.4.3, 6.4.4	<p>Performance Security amounting to total 10% of contract value shall be submitted as follows:</p> <p>(i) Contractor shall submit Performance Security @ 10% in advance at the time of signing of agreement in form of BG as per latest rules under RTPP act. The BG should be issued by any nationalized / schedule bank and shall remain valid up to 60 days beyond defect liability period. Bank Guarantee submitted against the performance guarantee, shall be unconditional and en-cashable/invokable at Udaipur.</p>

	<p>(ii) If there is no reason to retain the PG, it shall be returned back to the contractor within 60 days after the satisfactory completion of the defect liability period.</p> <p>(iii) Refer clause 4.3.1 of Special condition of contract</p>
7.1	<p>A) First Appellate Authority shall be: Vice President USCL i.e. Collector, Udaipur</p> <p>B) Second Appellate Authority shall be: Chairman USCL i.e. Principal Secretary, LSG</p>

Section-III: Evaluation and Qualification Criteria

SECTION III: EVALUATION AND QUALIFICATION CRITERIA

A. Evaluation Criteria

The successful Bid will be the lowest evaluated responsive Bid, which qualifies technical evaluation. This evaluation will consist of the following:

- 1.1 Evaluation of the Bidder's Technical Proposal and Presentation will include an assessment of the Bidder's technical capacity to mobilize key equipment and personnel for the contract consistent with its proposal regarding work methods, scheduling, and material sourcing in sufficient detail.
 - 1.2 Quantifiable Nonconformities, Errors and Omissions.
 - 1.3 Demonstrate capability to undertake similar Works contracts, by documented demonstration of execution of similar type of works. The bidder will submit Completion Certificate from the Employer/s.
- 2 The technical evaluation will require evidence of the following:

Sl. No.	Capability	Criteria for Technical Evaluation
1	Registration	Contractor must be registered as AA class category or equivalent category with any Government/ Semi Government/ PSU. Certificate to be provided mandatorily.
2	Successfully completion of a RCC frame structure project of similar size within the last 5 (Five) years	Minimum 1 (one) RCC frame structure project of amount Rs. 2.50 crore

B. Qualification Criteria:-

1. Eligibility:

	Criteria	Compliance Requirements			
		Requirement	Single Entity	Joint Venture	
	All Partners Combined			Each Partner	One partner
i) Nationality	National / International firm	Must meet requirement	Must meet requirement	Must meet requirement	Must meet requirement
ii) Conflict of Interest	No conflicts of interest in accordance with ITB Sub-clause 1.4.3	Must meet requirement	Must meet requirement	Must meet requirement	Must meet requirement

iii) Debarment/ Transgression by any Procuring Entity.	Must declare	Must meet requirement	Must meet requirement	Must meet requirement	Must meet requirement
---	--------------	--------------------------	--------------------------	--------------------------	--------------------------

2. Pending Litigation:

Pending Litigation	All pending litigation shall be treated as resolved against the Bidder and so shall in total not represent more than 50 percent of the Bidder's net worth.	Must meet requirement by itself	N/A	Must meet requirement by itself	N/A
---------------------------	---	---------------------------------	-----	---------------------------------	-----

NOTE: CA certificate must clearly mention, with calculation that pending litigation in total is not more than 50% of Bidder's Network. Network must also be certified by CA and is to be submitted with the technical bid.

3. Experience:

The bidder should have experience of the following in last five financial years (**2012-13 to 2016-17**); experience in current year shall also be counted upto deadline for submission of bid:

Criteria	Compliance Requirements			
	Single Entity	Joint Venture (permitted)		
Requirement			All Partners Combined	Each Partner
Successfully completion of a RCC frame structure project of similar size within the last 5 (Five) years of amount Rs. 2.50 crore and shall executed the following quantities in single work RCC Grade M -20 and above - 832 cum Steel (bar and structural both) - 156 tonne Shuttering - 80 sqm	Must meet requirement	Must meet requirement	NA	NA

4. Clients certificate of experience must clearly indicate whether

- (i) Completed and commissioned

Note:

- i) The Bidder shall submit copies of Work Orders, Completion Certificates in support of their experience claims issued by the Engineer not below than rank of Executive Engineer.

- ii) The works which have been completed during the period mentioned above, though may have commenced earlier will be considered as experience.
- iii) For considering experience of the bidder, out of its experience as JV, its share of works within the JV shall be considered with relevant documentation/certificates.
- iv) JV shall comprise of not more than two firms/companies. The minimum equity of the lead firm of the JV must be 51% and that of the other firm must 25%, at the minimum.

5. Financial:

Criteria	Compliance Requirements			
	Single Entity	Joint Venture (permitted)		
Requirement		All Partners Combined	Each Partner	One partner
5.1 Networth				
Net worth shall be positive in last financial year i.e. 2015-16	Must meet requirement	Must meet requirement	Must meet requirement	NA
5.2 Turnover				
Average Annual Turnover of last three Financial years (2013-2014 to 2015-16) should be equal to or more than Rs. 7.54 Crore.	Must meet requirement	Must meet requirement	Must meet minimum 25% requirement	Lead member must meet minimum 60 % requirement
5.3 Working Capital				
Working Capital based on the current assets and current liabilities (including the short term loan repayments due in current years) should be more than or equal to Rs. 1.88 Crore (Available working capital should be evaluated as current assets + revolving line of credit – current liabilities including loan repayments due within one year). NOTE: certificate of CA must be submitted indicating clearly that the working capital is as per formula given in tender document and clearly stating the individual components. CA must also clearly mention that he has gone through the revolving line of credit which is issued by scheduled bank and bank's commitment is	Must meet requirement	Must meet requirement	Must meet minimum 25% requirement	Lead member must meet minimum 60 % requirement

<p>project specific, assured and without any ambiguity and shall be available till final completion of the project, otherwise bid shall not considered. For revolving line of credit, Banks letter should be attached. The bank issuing revolving line of credit has to be scheduled bank as per format, otherwise it shall not considered.</p>				
5.4 BID CAPACITY:				
<p>Bid Capacity: The bid capacity of the bidder shall not be less than Rs. 7.54 Crore.</p> <p>The formula for calculating Bid capacity is given here</p> <p>Bid Capacity=(2xAxN)-B Where A= Maximum value of Annual Turnover from in any one year during the last three financial years (14-15,15-16, 16-17) (updated to present price level) N=Prescribed completion period of the work for which bids are invited in years, B= Value at present price level (2016-17) of existing commitments and ongoing works to be completed during N period i.e., the period of completion of works for which bids are invited.</p>	Must meet requirement	Must meet requirement	Must meet minimum 25% requirement	Lead member must meet minimum 60 % requirement

NOTE:

The **certificate of CA regarding Net worth, Turnover, Working Capital, revolving line of credit and Bid Capacity must be submitted otherwise bid shall not be considered.** The certificate should clearly show the calculation how the Bid Capacity is calculated as per formula given in tender. The contractor should submit an undertaking on stamp paper of Rs. 500 that he has divulged all necessary and relevant information regarding current contract commitments for projects being executed by the bidder, which is necessary for calculation of B value for the calculation of Bid Capacity. The audited balance sheet of last five years shall be provided

Section-IV: Bidding Forms

SECTION IV: BIDDING FORMS

Table of contents

S. No	Particulars
4.1	Technical Bid Check List
4.2	Letter of Technical Bid
4.3.1	Bid Security (Bank Guarantee Unconditional)
4.3.2	Bid Security Declaration
4.4.1	Form ELI-1
4.4.2	Form ELI-2
4.4.3	Form LIT-1
4.4.4	Form EXP - Key Activities
4.4.5	Form EXP - Construction Activities
4.4.6	Form : Revolving line of credit
4.4.7	Declaration by the Bidder under Sections 7 and 11 of the Act
4.5	List of Equipment
4.6	Manpower
4.7	Letter of Financial Bid
4.8	Price Bid BoQ
4.9	Power of Attorney
4.10	Joint Venture Agreement
4.11	Statement for work in hand
4.12	Check Points
4.13	Self-Appraisal Sheet

4.1 TECHNICAL PROPOSAL [WITH REFERENCE TO SECTION III]

CHECK LIST

In addition to the forms given in this section, a Technical Proposal must necessarily contain the following, otherwise the bid shall be considered incomplete and may lead to non-responsive.:

1. Notice Inviting Bid
2. CA's certificates for Net worth, Turnover, Working Capital, Revolving Line of Credit and Bid Capacity
3. Bank's letter as required in Tender Document (if applicable).
4. Sales Tax Registration in State of Rajasthan (Optional),
5. VAT / Sales Tax Clearance Certificate
6. GST Registration
7. Copy of PAN & TAN Numbers
8. Service Tax Registration, if required as per law
9. Proof of payment of Bid Security
10. Proof of Cost of bidding document or receipt of such cost.
11. Proof of Bid processing fee as specified.
12. Bid capacity stipulations as required in Tender Document.
13. Completion Certificates of works which have been cited in support of fulfillment of eligibility criteria as specified in Tender Document.
14. Work orders of works which have been cited in support of fulfillment of eligibility criteria as specified in Tender Document.
15. Drawings / designs / technical documents (if required) in support of works to be executed
16. Any modifications or withdrawal
17. Other documents considered necessary to strengthen the bid
18. JV agreement against which experience for eligibility is claimed to demonstrate clearly the JV members work in that JV
19. Check Points and Self appraisal sheet
20. Audited Annual Reports for last 3 years

4.2 Letter of Technical Bid

Technical Bid Submission Sheet

Date: _____

NIB No.: _____

To: _____

We, the undersigned declare that:

(a) We have examined and have no reservations to the Bidding Document, including Addenda No. _____

(b) We offer to execute in conformity with the Bidding Document the following Works:

(c) Our Bid shall be valid for a period of 180 days from the date fixed for the bid submission deadline in accordance with the Bidding Document, and it shall remain binding upon us and may be accepted at any time before the expiration of that period;

(d) If our Bid is accepted, we commit to obtain a Performance Security in the amount of _____ percent of the Contract Price or Performance Security Declaration, as the case may be, for the due performance of the Contract;

(e) Our firm or suppliers for any part of the Contract, have nationalities from the eligible countries;

(f) We are not participating, as Bidder, in more than one Bid in this bidding process, other than alternative offers, if permitted, in the Bidding Document;

(g) Our firm, its affiliates or subsidiaries or suppliers has not been debarred by the State Government or the Procuring Entity;

(h) We understand that this Bid, together with your written acceptance thereof included in your notification of award, shall constitute a binding contract between us, until a formal Contract is prepared and executed;

(i) We understand that you are not bound to accept the lowest evaluated bid or any other bid that you may receive;

(j) We agree to permit Government of Rajasthan or the Procuring Entity or their representatives to inspect our accounts and records and other documents relating to the bid submission and to have them audited by auditors appointed by the Procuring Entity;

(k) We have paid, or will pay the following commissions, gratuities, or fees, if any, with respect to the bidding process for execution of the Contract:

Name of Recipient	Address	Reason	Amount

(l) We declare that we have complied with and shall continue to comply with the provisions of the Code of Integrity including Conflict of Interest as specified for Bidders in the Rajasthan Transparency in Public Procurement Act, 2012, the Rajasthan Transparency in Public Procurement Rules, 2013 and this Bidding Document during this procurement process and execution of the Works as per the Contract;

(m) Other comments, if any:

Name/ address: _____

In the capacity of: _____

Signed: _____

Duly authorized to sign the Bid for and on behalf of: _____

Date: _____

Tel: _____ Fax: _____

E-mail: _____

4.3.1 Bid Security (Bank Guarantee Unconditional)*

Form of Bid Security

[insert Bank's Name, and Address of Issuing Branch or Office]
Beneficiary: *[Chief Executive Officer, Udaipur Smart City Limited]*

Date: *[insert date]*

BID GUARANTEE No.: *[insert number]*

We have been informed that ***[insert name of the Bidder]*** (here in after called "the Bidder") has submitted to you its bid dated ***[insert date]*** (hereinafter called "the Bid") for the execution of ***[insert name of contract]*** under Notice Inviting Bids No. ***[Insert NIB number]*** ("the NIB").

Furthermore, we understand that, according to your conditions, bids must be supported by a bid guarantee.

At the request of the Bidder, we ***[insert name of Bank]*** hereby irrevocably undertake to pay you any sum or sums not exceeding in total an amount of ----- ***[insert amount in figures][insert amount in words] at the bank branch _____ located at Udaipur*** upon receipt by us of your first demand in writing accompanied by a written statement stating that the Bidder is in breach of its obligation(s) under the bid conditions, because the Bidder:

- (a) has withdrawn its Bid during the period of bid validity specified by the Bidder in the Letter of Technical Bid; or
- (b) having been notified of the acceptance of its Bid by the *Procuring Entity* during the period of bid validity,
 - (i) fails or refuses to execute the Contract Agreement,
 - (ii) fails or refuses to furnish the performance security, in accordance with the Instructions to Bidders (hereinafter "the ITB"),
- (c) has not accepted the correction of mathematical errors in accordance with the ITB, or
- (d) has breached a provision of the Code of Integrity specified in the TB;

This guarantee will expire: (a) if the Bidder is the successful Bidder, upon our receipt of copies of the contract signed by the Bidder and the performance security issued to you upon the instruction of the Bidder; and (b) if the Bidder is not the successful Bidder, upon the earlier of (i) our receipt of a copy of your notification to the Bidder of the name of the successful Bidder; or (ii) thirty days after the expiration of the validity of the Bidder's bid.

Consequently, any demand for payment under this guarantee must be received by us at the office on or before that date.

Signed: _____

[Insert signature of person whose name and capacity are shown]

NOTE: * - Scheduled Bank Only

Name: _____

[insert complete name of person signing the Bid Security]

In the capacity of: _____

[insert legal capacity of person signing the Bid Security]

Duly authorized to sign the Bid Security for and on behalf of _____

[insert name of the Bank]

Dated on day of ,

[insert date of signing]

Bank's Seal _____

[affix seal of the Bank]

[Note: In case of a Joint Venture, the Bid-Security must be in the name of all partners to the Joint Venture/Lead bidder that submits the bid.]

4.3.2 Bid Security Declaration

Date: ***[insert date (as day, month and year)]***

Bid No.: ***[insert number of bidding process]***

Alternative No, if permitted: ***[insert identification No if this is a Bid for an alternative]***

To: ***[Chief Executive Officer, USCL, RAJASTHAN]***

We, the undersigned, declare that:

We understand that, according to your conditions, bids must be supported by a Bid-Securing Declaration.

We accept that we will automatically be suspended from being eligible for bidding in any contract with you, the Procuring Entity for the period of time of ***[insert number of months or years, as required by the Procuring Entity]*** starting on ***[insert date]***, if we are in breach of our obligation(s) under the bid conditions, because we:

(a) withdraw our Bid during the period of bid validity specified in the Letter of Bid; or

(b) do not accept the correction of errors in accordance with the Instructions to Bidders (hereinafter "the ITB"); or

(c) having been notified of the acceptance of our Bid by you, the Procuring Entity, during the period of bid validity, (i) fail or refuse to sign the Contract, if required, or (ii) fail or refuse to furnish the Performance Security Declaration, in accordance with the ITB; or

(d) breach any provisions of the Code of Integrity as specified in the ITB;

We understand this Bid-Securing Declaration shall expire if we are not the successful Bidder, upon the earlier of (i) our receipt of your notification to us of the name of the successful Bidder.

Signed: _____

[insert signature of person whose name and capacity are shown]

Name: _____

[insert complete name of person signing the Bid-Securing Declaration]

In the capacity of: _____

[insert legal capacity of person signing the Bid-Securing Declaration]

Duly authorized to sign the bid for and on behalf of: _____

[insert complete name of Bidder]

Dated on _____ day of _____,

[insert date of signing]

Corporate Seal _____

[affix corporate seal of the bidder]

[Note: In case of a Joint Venture, the Bid-Securing Declaration must be in the name of all partners to the Joint Venture/ Lead bidder that submits the bid.]

4.4.1 Bidder's Qualification

To establish its qualifications to perform the contract in accordance with Section III (Evaluation and Qualification Criteria) the Bidder shall provide the information requested in the corresponding Information Sheets included hereunder.

4.4.1(a) Form ELI - 1: Bidder's Information Sheet

BIDDER'S INFORMATION	
Bidder's legal name	
In case of JV/Consortium, legal name of each partner	
Bidder's /all JV/Consortium partners country of constitution.	
Bidder's /all JV/Consortium partners year of constitution	
Bidder's /all JV/Consortium partners legal address in country of constitution	
Bidder's /all JV/Consortium partners authorized representative (name, address, telephone numbers, fax numbers, e-mail address)	
<p>Attached are self attested copies of the following original documents:</p> <ol style="list-style-type: none"> 1. In case of single entity, certificate of registration/ incorporation and memorandum of association or constitution of the legal entity named above. 2. Authorization to represent the firm or JV named in above. 3. In case of JV, letter of intent to form JV or JV agreement. 4. In case of Consortium, letter of intent to form consortium or JV consortium 	

4.4.2 Form ELI : JV Information Sheet

Attach the Letter of Intent to form JV or certificate of registration/ incorporation and memorandum of association or constitution of the legal entity, if JV is already in existence.

Each member of a JV / must fill in this form

JV /consortium/ SPECIALIST CONTRACTOR'S INFORMATION	
Bidder's legal name	
JV /consortium Partner's legal name	
JV /consortium Partner's financial share in the JV	
JV /consortium Partner's country of constitution	
JV /consortium Partner's year of constitution	
JV /consortium Partner's legal address in country of constitution	
JV /consortium Partner's authorized representative information(name, address, telephone numbers, fax numbers, e-mail address)	
Attached are attested copies of the following original documents:	
<ol style="list-style-type: none"> 1. Certificate of registration/ incorporation and memorandum of association or constitution of the legal entity named above. 2. Authorization to represent the firm named above. 	

4.4.3 Form LIT 1- Pending Litigation

Each Bidder or member of a JV / must fill in this form

Pending Litigation			
<ul style="list-style-type: none">• No pending litigation in accordance with Section III (Evaluation and Qualification Criteria).• Pending litigation in accordance with Section III (Evaluation and Qualification Criteria)			
Year	Matter in Dispute	Value of Pending Claim in INR	Value of Pending Claim as a Percentage of Net Worth

4.4.4 Form EXP: Project Experience in Key Activities

Fill up one (1) form per contract

Contract with Similar Key Activities			
Contract No. of.	Contract Identification		
Award Date		Completion Date	
Total Contract Amount	-----Equivalent INR -----		
If partner in a JV, specify participation of total contract amount	Percent of Total	Amount	
Employer's Name Address Telephone Number Fax Number E-mail			
Description of the key activities in accordance with Criteria.			
Successfully completion of a RCC frame structure project of similar size within the last 5 (Five) years of amount Rs. 2.50 crore and shall executed the following quantities in single work RCC Grade M -20 and above - 832 cum Steel (bar and structural both) - 156 tonne Shuttering - 80 sqm			
Reference page number, copy of work order and completion certificate issued by the rank not below than Executive Engineer in support of above experience to be submitted.			

4.4.5 Form EXP: Project Experience in Construction Activities

Fill up one (1) form per contract

Contract with Similar Key Activities			
Contract No. of	Contract Identification		
Award Date		Completion Date	
Total Contract Amount	-----Equivalent INR -----		
If partner in a JV, specify participation of total contract amount	Percent of Total	Amount	
Employer's Name Address Telephone Number Fax Number E-mail			
Description of the key activities in accordance with Criteria.			
Reference page number, copy of work order and completion certificate in support of above experience to be submitted.			

4.4.6 Format for assured Revolving line of credit facility

(To be submitted by a Scheduled Bank on the Bank's Letter head)

Date: *(Insert Date)*

To: Chief Executive Officer,
Udaipur Smart City Limited,
Udaipur

Subject: Letter of Assurance for Revolving line of credit facility for INR ----

Dear Sir,

WHEREAS _____ [name and address of Bidder] (**hereinafter called the "Bidder"**) intends to submit a bid for----- (name of contract package) -----" under the Udaipur Smart City Limited (**hereinafter called the "Employer"**) in response to the Invitation for Bids issued by the Udaipur Smart City Limited through NIB no. -----; and

WHEREAS the Bidder has requested that an assured revolving line of credit be provided to it for executing the ----- (name of contract package) -----
-----In the event that the Contract is awarded to it; then

KNOW ALL THESE PEOPLE by these presents that We _____ [name of Bank] of _____ [name of Country] having our registered office at _____ [address of registered office] are willing to provide to _____ (the Bidder) a sum of up to _____ [amount of guarantee in figures and words] as an assured revolving line of credit for executing the Works under ----- (name of contract package) -----should the Bidder be awarded the contract based on its tendered prices.

We understand that this assurance may be taken into consideration by the Employer during evaluation of the Bidder's financial capabilities, and further assure that we intend to maintain this revolving line of credit until such time as the Works are completed and taken over by the Employer.

SEALED with the Common Seal of the said Bank on the ____ day of _____, 2017.

Date: _____

Signature of the Bank: _____

Witness: _____ Seal: _____

[Signature, name and address]

4.4.7 Declaration by the Bidder in compliance of Section 7 & 11 of the Act

Declaration by the Bidder/ JV

In relation to our Bid submitted to [enter designation and address of the procuring entity] for procurement of [insert name of the Works] in response to their Notice Inviting Bids No..... Dated we hereby declare under Section 7 and 11 of the Rajasthan Transparency in Public Procurement Act, 2012, that;

1. We possess the necessary professional, technical, financial and managerial resources and competence required by the Bidding Document issued by the Procuring Entity;
2. We have fulfilled our obligation to pay such of the taxes payable to the Central Government or the State Government or any local authority, as specified in the Bidding Document;
3. We are not insolvent, in receivership, bankrupt or being wound up, not have my/our affairs administered by a court or a judicial officer, not have my/our business activities suspended and are not the subject of legal proceedings for any of the foregoing reasons;
4. We do not have, and our directors and officers not have, been convicted of any criminal offence related to our professional conduct or the making of false statements or misrepresentations as to our qualifications to enter into a procurement contract within a period of three years preceding the commencement of this procurement process, or not have been otherwise disqualified pursuant to debarment proceedings;
5. We do not have a conflict of interest as specified in the Rajasthan Transparency in Public Procurement Act, the Rajasthan Transparency in Public Procurement Rules and this Bidding Document, which materially affects fair competition;
6. We have complied and shall continue to comply with the Code of Integrity as specified in the Rajasthan Transparency in Public Procurement Act, the Rajasthan Transparency in Public Procurement Rules and this Bidding Document, till completion of all our obligations under the Contract.

Date:

Signature of Bidder

Place:

Name:

Designation:

Address:

4.5 Details of Machinery and Equipment available and proposed to be deployed for the Execution of the Tendered Work

S. No.	Particulars of Machinery	Availability	Owned	Year of Manufacture	Serviceable of Unserviceable	Location where Presently in Operation or in store	Proposed Deployment for tendered work
(1)	(2)	(3)	(4)	(5)	(6)	(7)	(8)
1							
2							
3							
4							
5							
6							
7							
8							
9							
10							

- i. **I/We hereby certify that the above information is correct to the best of my/our knowledge and belief, the documentary proof of possession of the Machinery and Equipment required are submitted with the bid.**
- ii. I/We hereby undertake to deploy the machinery and equipment listed above as and when required in the execution of the work.

Date:

Signature of Bidder

Place:

Name:

Designation:

Address:

4.6 Personnel (Engineers, Technical Staff, Supervisory Staff, Operators etc.) and their deployment

Required with the Bidder

Civil Engineers, with more than 6 yrs experience – one nos.

Supervisors, with more than six years' experience – two nos.

S. No.	Name	Designation	Technical Qualification	Date from which working with Consultant	Present Deployment (Name of work)	Proposed Deployment on work put to tender
1	2	3	4	5	6	7
1						
2						
3						
4						
5						

4.7 Letter of Financial Bid

Date: _____

NIT No.: _____

To,
Chief Executive Officer,
Udaipur Smart City Limited,
Udaipur

Sub: - Selection of Agency for Development of Parking Facility at Gulab Bagh, Udaipur - Our Offer

We, the undersigned, declare that:

(a) We have examined and have no reservations to the Bidding Document, including Addenda No.: _____

(b) We offer to execute in conformity with the Bidding Document the following Works:

(c) The total Price for our Bid, excluding any discounts offered, if permitted, in item (d) below is: _____

(d) The discounts offered, if permitted, and the methodologies for their application are: _____

(e) We understand that this Bid, together with your written acceptance thereof included in your notification of award, shall constitute a binding contract between us, until a formal Contract is prepared and executed.

(f) We understand that you are not bound to accept the lowest evaluated bid or any other bid that you may receive.

(g) Other comments, if any:

Name/ address: _____

In the capacity of: _____

Signed: _____

Duly authorized to sign the Bid for and on behalf of: _____

Date: _____

Tel: _____ Fax: _____

E-mail: _____

4.8 PRICE BID BoQ

Note: To be provided separately

4.9 POWER OF ATTORNEY

Power of Attorney for Authorized Representative

The firm M/s.....authorize the following Representative to sign and submit the tender document, negotiate terms and conditions for the contract, to sign the contract, to deal with the _____, to issue and receive correspondence related to all matters of the tender "-----". We / M/s _____ undertake the responsibility due to any act of the representative appointed hear by.

For Partnership Firm's

S. No.	Name of the All Partner	Signature of Partner with Seal
1.		
2.		
3		
4	Name and Designation of the person Authorized	
5	Attested Signature of the Authorized Representative	

For Limited Firm's

Name and Designation of the person Authorized	
Firm	
Address	
Telephone No.	
Fax No.	
Telex No.	
Authority By which the Powers is delegated	
Attested Signature of the Authorized Representative	
Name and Designation of person attesting the signatures	

4.10 Joint Venture Agreement (Between not more than two firms)

(ON Rs 1000 STAMP PAPER OR NOTARY)

Memorandum of Understanding for JOINT VENTURE

This Memorandum of Understanding (hereinafter referred to as "MOU") is made and entered into this ----- ("Effective Date").

BETWEEN

M/s. _____, a company incorporated, and having its registered office at _____.(Hereinafter referred to as the "**First Party**"/ "**One Partner**");

M/s. _____ a company incorporated, and having Registered office at _____.(Hereinafter referred to as the "**Second Party**"/ "**Each Partner**");

Hereinafter jointly referred to as the "**Parties**" and individually as "**Each Party**" or "**a Party**" as the case may be.

WHEREAS,

A) **The Udaipur Smart City Limited, Udaipur, Rajasthan (hereinafter referred to as the USCL or procuring entity) invited bid for**

_____,
(B) The **Parties** hereto formed a Joint Venture or will form a joint venture (hereinafter referred to as the "**JV**") to jointly execute the above project in all respect

(Note: In case of JV executed on notary basis and become the lowest successful bidder, Joint venture has to be registered within 15 days of issuing of LOA)

NOW THEREFORE IT IS HEREBY AGREED as follows

ARTICLE 1: JOINT VENTURE:

1.1. The Parties hereto agree to form the Joint Venture with _____ designated as the

One Partner and First Partner.

1.2. _____ shall be the **Second Member – or Second Partner**

ARTICLE 2: JOINT VENTURE NAME:

2. The JV shall do business in the name of "**_____ Joint Venture**".

ARTICLE 3: JOINT AND SEVERAL LIABILITY:

3. The **Parties** hereto shall, for the above-referred **Projects**, be jointly and severally liable to the **Employer** for the execution of the Projects in accordance with the **Contract** till the actual completion of Contract including defect liability period and operation & maintenance as per bid conditions.

ARTICLE 4: PROPORTIONATE SHARE:

4.1 Each member of the Joint Venture agrees to place at the disposal of the Joint Venture, the benefit of all its experience, technical knowledge and skill, and shall in all respects bear its share of responsibility and burden of completing the contract. The parties herein shall be responsible for physical and financial distribution of work as under.

Lead Partner: Financial responsibility: -----
Physical responsibility: -----

Other Partners: Financial responsibility: -----
Physical responsibility: -----

4.2 All rights, interests, liabilities, obligations, risks, costs, expenses and pecuniary obligations and all net profits or net losses arising out of the **Contract** shall be shared or borne by the **Parties** in the above **Proportions**.

4.3 The members in the proportion as mention in article 4.1, shall contribute sufficient Initial fixed capital for timely execution of the project including commissioning & operating period as per the contract.

ARTICLE 5: JOINT EFFORT AND MANAGEMENT:

5.1 The **Parties** shall participate as a **JV** in the submission of bids and further negotiations with the **Employer** and shall co-operate and contribute their respective expertise and resources to secure and execute the **Projects**.

5.2 On award of **Projects**, the **First Partner** in consultation with the other members of **JV** will decide on the final management structure for the successful execution of the **Projects** as per the terms of **Contract**.

5.3 All the **Parties** hereby agree to pool in their financial, administrative, managerial, technical and material resources for execution of the **Projects**, including commissioning & operation for the period as stipulated in the contract. The share of interest of the **JV** shall be as per the mutual understanding for the successful completion of the project.

ARTICLE 6: EXCLUSIVITY:

6.1 The co-operation between the **Parties** hereto shall be mutually exclusive i.e. none of them shall without the other **Party's** consent & prior approval of **USCL**, approach or cooperate with any other parties in respect of the Project.

6.2 In the course of working as associates, the parties to the **JV** will be sharing information with each other which may be proprietary /confidential information /knowledge acquired by each other. It is hereby agreed that the parties will maintain complete secrecy regarding such information / knowledge and will not divulge to any party for any other purpose except for the success of the joint execution of the contract. All parties will also indemnify each other against any claim that may arise out of using information, which are being claimed proprietary.

ARTICLE 7: Memorandum of Understanding:

7.1 This **Memorandum of Understanding** shall be terminated:-

- a. if the **Parties** mutually confirm that the **JV's** bid proposal has not been finally accepted by **Employer** and all rights and obligations of the **Parties** under or in connection with this **Memorandum of Understanding** have ceased, or
- b. after successful completion of the project including commissioning & operation and defect liability period from the date of this **Memorandum of Understanding**

unless extended for a further period on demand of **USCL** & mutual consent of the Parties, or

7.2 The **Memorandum of Understanding** can be modified by mutual consent of the Parties to suit the efficient and expeditious execution of Projects including commissioning & operation of Plant or to make this agreement more meaningful to suit the requirements of Employer **after the consent of the Employer**.

ARTICLE 8: ARBITRATION:

8.1 Any dispute resulting from this Agreement shall be settled amicably by mutual Consultation by the Managing Directors/Chairman of _____ & _____. In the event that an amicable settlement is not reached within 60 days in any particular case, the dispute shall be referred to arbitration and shall be resolved in accordance with and subject to the provisions of the _____ and any statutory modifications and enactment hereof for the time being in force. The decision of the arbitrators shall be final and binding upon both parties. The venue of arbitration will be _____.

ARTICLE 9: GOVERNING LAWS:

9.1 This Agreement shall in all respects be governed by and interpreted in accordance with the _____ Laws.

ARTICLE 10: CONFIDENTIALITY:

10.1 No Party hereto shall disclose to any other party any information of a confidential nature including but not limited to trade secrets, know-how acquired from any Party in connection with the subject matter of this Agreement.

ARTICLE 11: ADDRESS OF CONSORTIUM:

Any and all correspondence from the Employer to the **JV** shall be addressed to **(name of JV)** at the address stated herein below—(any one of the partners). The address of the Consortium office of the partner companies will be deemed to be the address for the purpose of communication.

The notice, if any required to be served on the party by the other party, will be deemed to be served, if the said notice / communication is delivered by Registered Post at the respective address **(name of JV)**

ARTICLE 12: Authorized Representative:

The JV shall nominate a Representative who shall have the authority to conduct all business for and on behalf of any and all the parties of the JV during the bidding process and, in the event the JV is awarded the Contract, during contract execution.

Authorized Representative of JV: _____

ARTICLE 13: ASSIGN ABILITY:

13.1 The interests and rights of a Party in the Contract and as a Party of the Joint Venture shall not be transferable or assignable without the written consent of the Employer & other party.

ARTICLE 14: INTERPRETATION OF HEADINGS:

14. The headings of each of the Articles herein contained are inserted merely for convenience of reference and shall be ignored in the interpretation and construction of any of the provisions herein contained.

ARTICLE 15: OTHERS

15.1 Any other matters not contained in this Agreement shall be discussed and amicably agreed upon by the Parties in the spirit of mutual trust and cooperation for timely completion of project including commissioning & operation of project. Notwithstanding anything above all the Parties are severally and jointly responsible to the Employer for execution of the Contract:

IN WITNESS WHEREOF the Parties hereto have caused this Agreement to be executed by each of the duly authorized representatives as appearing below:-

Signed by)
For and on behalf of)

_____)

in the presence of:)

Name:
Designation:

Name:
Designation:

Signed by)
For and on behalf of)

_____)

in the presence of:)

Name:
Designation:

Name :
Designation:

4.11 Bidding Capacity

4.11.1 STATEMENT FOR WORK IN HAND (for calculation of value of B)

This is to certify that the status of the present works in hand as on **date of publication of NIT** of order value more than Rs. 10.00 lacs for which either order are received or the work is under execution but which are still not completed is as under:

Amount In Lac Rs.

S. No	Brief Description of Work	Stipulated Date of Start	Stipulated Date of Completion	Time left for execution after date of publication of NIT , in months	Cost of awarded work	Cost of work executed up to date of publication of NIT	Balance Cost of un-executed work as on date of publication of NIT in 30 month from and date of submission
1	2	3	4	5	6	7	8=6-7

1. If the value of Balance work goes beyond 30 months from the date of bid submission then client certificate mentioning the amount of work to be executed beyond 30 months, otherwise full balance work shall be accounted for calculation of 'B' value.

2. This is certified that this is true in all respect and can be used for calculation of the bidding capacity as per the formula given in ITB. This is also certified that other orders under execution by the firm shall not materially affect the bidding capacity of the firm as required in this tender. **(Format should be on Rs 500/= stamp paper)**

Signatures With Seal of Authorized Signatory for tender

4.12 Check Points must be filled by Bidder

S. No.	Requirements / Documents required to be submitted		Check Points	Yes / No	Enclosed at page no. of bid and any other detail as required
	GENERAL				
1	Cost of Bid Document as Rs. 10,000/-	DD/Cheque in favour of Chief Executive Officer, Udaipur Smart City Limited Original hard copy to be submitted in the office of Chief Executive Officer, Udaipur Smart City Limited by date and time mentioned in NIB and scanned copy to be uploaded with technical bid	Confirm it is of scheduled bank ? Name of Bank Amount Rs. 10000.00 In favour of Chief Executive Officer, Udaipur Smart City Limited		
2	Bid Processing Fee of Rs 1,000/-	DD/Cheque in favour of MD, RISL Original hard copy to be submitted in the office of Chief Executive Officer, Udaipur Smart City Limited by date and time mentioned in NIB and scanned copy to be uploaded with technical bid	Confirm it is of scheduled bank? Name of Bank Amount Rs. 1000.00 In favour of MD, RISL		
3	Bid Security at 2% of estimated procurement cost In case of JV, the Bid Security must be in the name of all partners to the Joint Venture / Lead bidder that submits the bid. Should be valid up to _____	DD / Bankers Cheque / Bank Guarantee as per format Original hard copy to be submitted in the office of Chief Executive Officer, Udaipur Smart City Limited by date and time mentioned in NIB and scanned copy to be uploaded with technical bid	Confirm that as per format? Confirm that it is in prescribed format? If not, liable to be rejected. Confirm that it is unconditional? If any condition bid liable to be rejected. State in whose name is bid security (JV or Lead Bidder) BG number Confirm that BG is Valid up to 30		

S. No.	Requirements / Documents required to be submitted		Check Points	Yes / No	Enclosed at page no. of bid and any other detail as required
			days beyond the validity of bid		
			Confirm it of a scheduled bank?		
			Mention the Name of bank.		
			Amount		
4	Power of Attorney	On Stamp Paper, Original hard copy to be submitted in the office of Chief Executive Officer, Udaipur Smart City Limited by date and time mentioned in NIB and scanned copy to be uploaded with technical bid	Confirm that value of Stamp Paper is Rs. 500/-		
			Name & designation of person who has issued POA		
			Name & designation of person to whom POA is issued		
5	Joint Venture Agreement	Agreement/Notary as per format (not more than two companies) Original hard copy to be submitted in the office of Chief Executive Officer, Udaipur Smart City Limited by date and time mentioned in NIB and scanned copy to be uploaded with technical bid	Confirm that value of Stamp Paper is Rs. 1000/-		
			Confirm that financial responsibility of lead partner is minimum 51%		
			Confirm that financial responsibility of other partner bidder is minimum 25%		
			Confirm that JV is in prescribed format. If not, liable to be rejected.		

4.13 SELF APPRAISAL SHEET TO BE FILLED BY THE BIDDER FOR DETERMINATION OF RESPONSIVENESS

S. No.	Requirements as per bid document	Check points	Tick the correct option or fill in information	Enclosed at page no. of bid and any other detail as required
General Requirements				
1	VAT Registration /clearance certificate	Confirm that submitted	Yes / No	
2	VAT Registration in Rajasthan	Confirm that submitted with this bid or will be submitted later as per clause _____	Yes / later after award	
3	PAN & TAN Numbers	Confirm that submitted	Yes / No	
Eligibility Criteria				
4	Nationality - Indian/International firms	Specify nationality	Indian/International	
5	Declaration Requirement to be fulfilled by: Each of the consortium / JV member	Confirm that declaration submitted by bidder / each partner in case of JV	Yes / No	
		Confirm that it is in the prescribed format. If not, bid is liable to be rejected	Yes / No	
6	Declaration regarding Debarment/Transgression by any procuring entity Requirement to be fulfilled by: Each of the consortium / JV member	Confirm that declaration submitted by bidder / each partner in case of JV	Yes / No	
		Confirm that it is in the prescribed format; If not, bid is liable to be rejected	Yes / No	
7	Pending Litigation in Form LIT-1 - All pending litigation shall be treated as resolved against the bidder and so shall in total not represent more than 50 percent of Bidder's net worth Requirement to be fulfilled by: Each of the consortium / JV member	Confirm that declaration submitted by bidder / each partner in case of JV	Yes / No	
		Confirm that it is in the prescribed format; If not, bid is liable to be rejected	Yes / No	
		Confirm that value of litigations is less than 50% of bidder's net worth and CA certificate showing calculation	Yes / No	
8	Successfully completion of a RCC frame structure project of similar size within the last	Number of works on basis of which eligibility is claimed.		

S. No.	Requirements as per bid document	Check points	Tick the correct option or fill in information	Enclosed at page no. of bid and any other detail as required																								
	<p>5 (Five) years of amount Rs. 2.50 crore and shall executed the following quantities in single work RCC Grade M -20 and above - 832 cum Steel (bar and structural both) - 156 tonne Shuttering - 80 sqm</p> <p>In case of JV, all partners combined should meet the requirement. i) Copies of Work Orders, Completion and satisfactory performance Certificates in support of their experience claims. Only works of Govt/PSU/Autonomous bodies under Govt. Sector shall be considered. The works which have been completed during the period mentioned above, though may have commenced earlier, shall be considered for experience purposes.</p> <p>For considering experience of the bidder, out of its experience as JV, its own works in the JV shall be considered with relevant evidence/certificates.</p>	<p>Details of qualifying works : Work no. 1</p> <table border="1" data-bbox="875 432 1574 1203"> <tr> <td data-bbox="875 432 1574 491">Name of work (in brief)</td> <td data-bbox="1574 432 1749 491"></td> <td data-bbox="1749 432 2022 491"></td> </tr> <tr> <td data-bbox="875 491 1574 528">Name of client</td> <td data-bbox="1574 491 1749 528"></td> <td data-bbox="1749 491 2022 528"></td> </tr> <tr> <td data-bbox="875 528 1574 564">Value of work done</td> <td data-bbox="1574 528 1749 564"></td> <td data-bbox="1749 528 2022 564"></td> </tr> <tr> <td data-bbox="875 564 1574 635">value of work done by bidder in case work is carried out in JV</td> <td data-bbox="1574 564 1749 635"></td> <td data-bbox="1749 564 2022 635"></td> </tr> <tr> <td data-bbox="875 635 1574 705">Stipulated Date of start (as per work order)</td> <td data-bbox="1574 635 1749 705"></td> <td data-bbox="1749 635 2022 705"></td> </tr> <tr> <td data-bbox="875 705 1574 786">Stipulated Date of completion (as per work order)</td> <td data-bbox="1574 705 1749 786"></td> <td data-bbox="1749 705 2022 786"></td> </tr> <tr> <td data-bbox="875 786 1574 922">If completed & commissioned, indicate Actual date of completion & commissioning (as per client's certificate). Confirm that this date is after 31.3.10.</td> <td data-bbox="1574 786 1749 922"></td> <td data-bbox="1749 786 2022 922"></td> </tr> <tr> <td data-bbox="875 922 1574 1203">Confirm any one of the following: i. Work is completed and commissioned ii. works is completed but could not be commissioned because of hindrances beyond control of contractor iii. Work is completed and commissioned at least of the amount required for qualification, out of large size contract.</td> <td data-bbox="1574 922 1749 1203"></td> <td data-bbox="1749 922 2022 1203"></td> </tr> </table> <p>Similar information to be given for each work if work done is more than one</p>	Name of work (in brief)			Name of client			Value of work done			value of work done by bidder in case work is carried out in JV			Stipulated Date of start (as per work order)			Stipulated Date of completion (as per work order)			If completed & commissioned, indicate Actual date of completion & commissioning (as per client's certificate). Confirm that this date is after 31.3.10.			Confirm any one of the following: i. Work is completed and commissioned ii. works is completed but could not be commissioned because of hindrances beyond control of contractor iii. Work is completed and commissioned at least of the amount required for qualification, out of large size contract.				
Name of work (in brief)																												
Name of client																												
Value of work done																												
value of work done by bidder in case work is carried out in JV																												
Stipulated Date of start (as per work order)																												
Stipulated Date of completion (as per work order)																												
If completed & commissioned, indicate Actual date of completion & commissioning (as per client's certificate). Confirm that this date is after 31.3.10.																												
Confirm any one of the following: i. Work is completed and commissioned ii. works is completed but could not be commissioned because of hindrances beyond control of contractor iii. Work is completed and commissioned at least of the amount required for qualification, out of large size contract.																												

S. No.	Requirements as per bid document	Check points	Tick the correct option or fill in information	Enclosed at page no. of bid and any other detail as required
9	Form FIN-2 - Net Worth in last financial year (Financial Year 2016-17) should be positive. The calculation sheet for annual net worth shall be certified by a Chartered Accountant.	Confirm that Certificate of Chartered Accountant for last financial year and calculation of net worth, attached; If not, bid is liable to be rejected Indicate value of net worth		
10	Form FIN-2 - Average Annual Turnover of last three financial years (Financial Year 2014-15 to 2016-17) should be equal to or more than 7.54 Crore . The calculation sheet for annual average turnover shall be certified by a Chartered Accountant. In case of JV, lead member should meet 60 percent (Rs. 4.524 crore) of the requirement	Confirm that Certificate of Chartered Accountant for each financial year and calculation of average value at present price level, attached; If not, bid is liable to be rejected Indicate value of average annual turn over		
11	Working Capital: Working Capital based on the current assets and current liabilities (including the short term loan repayments due in current years) should be 25% of the estimated cost of bid. (Available working capital should be evaluated as current assets + revolving line of credit – current liabilities including loan repayments due within one year).	Confirm that Certificate of Chartered Accountant for last financial year Indicate value of working capital based on formula		
12	Bid capacity	Confirm that affidavit of bid capacity submitted on Stamp Paper of Rs. 500.00 Confirm that certificate of CA submitted for Bid Capacity clearly showing calculation; If not, bid is liable to be rejected Value of A Value of B		

S. No.	Requirements as per bid document	Check points	Tick the correct option or fill in information	Enclosed at page no. of bid and any other detail as required
		Bid Capacity		
		Confirm that bidder has mentioned in affidavit that all works above Rs. 10 lakhs, to be completed in next 30 months (period of completion + bid validity period), required for determination of value of "B" are declared		
		Confirm that bank's letter submitted for revolving line of credit, If required		
		Confirm that the above bank's letter is as per format;		

Section-V : Procuring Entity's Requirements

SECTION V

REQUIREMENT OF WORKS

SCOPE OF WORK & GENERAL SPECIFICATIONS

Objective of the Work

This work is proposed for the purpose of developing parking facilities in Udaipur Town as per drawing at the following locations

- Near proposed Bird park, Gulab Bagh
- In front of Taiyabaiya School, Delhi Gate
- Near Chand Pole Gate

Scope of work

- The contractor is solely responsible for providing and executing all project works confirming all technical as well as quality standards as per TENDER DOCUMENT.
- The contractor shall promptly inform the Consultant engaged by USCL any error, omission, fault, or any other defect in the design or drawings or specification for the works, which he discovers when reviewing the contract documents, or in the process of execution of the works and collectively resolve the ambiguity or correct the error and will start the execution accordingly.
- Start execution after taking layout from EIC or his representative.
- Planning and taking up the work according to the Methodology/work plan or as per a modified work plan duly agreed and approved by the Engineer in charge.
- Underground and overhead services are likely to be met with during construction.
These are to be protected against damage by the Contractor at his own cost. The contractor shall be required to carry out removal / shifting of existing utilities as itemized in the BOQ. The contractor work program shall include this activity. The work shall be carried out under supervision of concerned department. The supervision charges of the line agencies shall be paid by the contractor and shall be reimbursed on actual on submission of receipt.
- Shifting of underground and overhead services other than itemized in the BOQ. The Procuring Entity would provide full support to contractor in coordinating with line agencies; however no claim on account of delay in shifting of utilities by line department will be admissible.
- All works pertaining to unforeseeable sub surface condition shall be

executed by the contractor at his own cost except for those for which payment is allowed in any other clause.

- The site should be cleaned of all the surplus material and broomed to leave a clean surface at the end of work.
- The contractor will be fully responsible for structural safety stability of the associated work.

Other Services

- Contractor shall take the necessary precautions to avoid the damage to other services such as water supply lines, telephone cables, electrical cables, storm water drains etc. In case of any damages to any of the services, Contractor shall be responsible for restoring the facilities in bare minimum time at his own cost. The other utility services and traffic shall be maintained. In case of shifting of any utilities, prior permission shall be taken from the Engineer and the same shall be carried out only after his written approval. The necessary deposit shall be paid to the concerned department or line agency in case the shifting / refixing of utility has to be carried out by the line agency. The actual expenditure incurred by the line agency shall be reimbursed to the Contractor by USCL.
- **Work program:** It is of utmost importance that the citizens of the town are inconvenienced to the minimum due to the works proposed to be carried out. The blocking of traffic and access to houses should be restricted for minimum period and the work done should be planned in a manner that it is commissioned in minimum time to provide benefits to the citizens inconvenienced.
- The contractor may provide his plan of work within 15 days of start for consideration of the EIC who may agree to a changed work program and the same shall be followed.

Unacceptable Works

All defective works are liable to be demolished, rebuilt and defective materials replaced by the Contractor at his own cost. In the event of such works being accepted by carrying out repairs etc. as specified by the Engineer, the cost of repairs shall be borne by the Contractor

Completion Drawings

- Completion Drawings on two prints and one polyester film 90/100 GSM shall be supplied by the Contractor, along with a soft copy in C.D.
- The Contractor shall submit to the Engineer-in-charge within two months of actual completion of the individual works but not later than the completion date of contract, “as built Drawings” as specified below. These Drawings shall be accurate and correct in all respects and shall be shown to and approved by the Engineer-in-charge.
- The completion drawings shall be grouped into following categories (i.e.)

plan, elevation and sections along the structural drawing also. Plan showing parking lot with the roads along with other details such as property width, storm water drains, footpaths, location of electrical / telephone poles along with all the dimensions wherever possible shall be prepared. The type of road, footpath details etc. shall be further elaborated in terms of their dimensions and material used.

Materials workmanship, period and certificates of Maintenance and Defect Liability etc.

All materials and workmanship shall be of the respective kinds described in the contract and in accordance with the Architect's/Engineer instructions and shall be subjected from time to time to such tests as the Engineer may direct at the place of manufacture or fabrication or on the site or at such other place or places as may be specified in the Contract or at all or any of such places. The contractor shall install quality control laboratory and provide such assistance, instruments, machines, labour and materials as are normally required for examining, measuring and test in any work and the quality, weight or quantity of any material used and shall supply samples of materials before incorporation in the works for testing as may be selected and required by the Engineer-in-charge.

Period of maintenance and Defects liability:

The Contractor shall be responsible to make good within such period as maybe stipulated by the Engineer in-charge any defect which may develop or may be noticed during period of maintenance of 36 months from the certified date of completion and which is attributable to the contractor. All notice of such defect shall be given to the Contractor promptly. In case the contractor fails to make good the defects, the Engineer in-charge may employ other persons to make good such defects and all expenses consequent thereof and incidental thereto shall be recoverable from the Contractor. In the event the employer takes over portions of work as they are completed the liability of the contractor under this clause for these portions shall extend to a period of 36 months from the actual dates on which portions of the works are taken over.

The successful bidder/contractor is required to undertake detailed photo recording documentation by still photography, videography of the entire work prior to commencement and the same has to be deposited with the Engineer in charge of

Udaipur Smart city limited in two copies immediately. Before dismantling any old work to redo this still photography with specifically putting some identity mark number of the portion by any specified means has to be done and this to be got checked and certified by Engineer In charge and recorded specifically in the measurement book (M.B.). A written permission from the Engineer in charge before commencement of executing such work is essential for execution as well as for payments.

During the work in progress and after its completion also photo documentation is necessary and the photos before & after completion of portion of work are essentially to be enclosed with the bill for payment.

Some of the important IS codes to be referred during execution of the work are as follows:

IS 3764 – Safety code for excavation works

Soil Investigation IS – 1988 – SBC

Concrete Works

IS.280 – Mild steel wire for general engineering purposes IS.269 – Portland cement

IS.383 – Coarse and fine aggregate

IS.432 – Medium tension steel bars and hard drawn steel wire IS.456 – Code of practice for plain and reinforced concrete IS.516 – Methods of testing for strength of concrete

IS.1199 – Method of sampling and analysis of concrete IS.1566 – Fabric reinforcement

IS.1786 – Cold twisted steel bars for concrete reinforcement

Reinforcement

IS. 3370 – Code of practice for concrete structures for the storage of liquids

IS. 7861 – Recommended practice for hot weather concreting (Part-I)

IS. 4082– Recommendation on stacking and storage of construction material on site.

General

IS.875 - Code of practice for structural safety of buildings, loading standards

IS.1911 – Dead loads

IS.1893 – Criteria for earthquake resistant design and structures IS.2950 – Design of raft

IS.1200 – Method of measurements

The following activities shall be carried out but shall not be limited to.

- (i) The contractor shall carry out topographical survey of site along with complete soil investigation like S.B.C., type of soil etc. and submit to Engineer-in-charge.

- (ii) Approval of all designs and drawings, material to be used, equipment's specifications and the samples, prior to commencing of work at site.
- (iii) Preparation and submission of all detail working drawings to the Engineer-in-charge.
- (iv) Submission of “As Built” drawings.

No separate payment will be made for the reconnaissance survey, laboratory test, testing and commissioning, etc. This shall be included in the rate quoted by the contractor.

General RCC

The specification for material shall comply with the specification narrated at relevant chapter of civil works and as written below:

Ordinary Portland Cement (OPC) Grade 43 conforming to IS: 269-1976 mark shall only be used. Cement manufactured in mini-cement plants / PPC shall not be used.

All **reinforcement** used shall be of TMT steel (Fe 415) ISI marked and from reputed manufacturer as approved by Engineer in Charge, shall be clean and free from loose mill scales, rust and coating of oil or other coatings which may destroy or reduce bond. Minimum size of reinforcement bars shall be of 8 mm. Only **steel shuttering** shall be used. Shuttering shall be new or in good condition without holes or dents. It has to be approved by the Engineer in Charge. The individual elements should be in the good shape to ensure a gap free shuttering according to the drawings. The paint used shall have good bonding and shall not stick to the concrete surface. Suitable system have to be provided for keeping the surface in place and keeping the correct distance in case of walls. The construction joints should be minimum and they have to be executed with most care. Before continuing concreting the loose material has to be removed and they have to be cleaned properly. Honey combing has to be avoided by suitable shuttering and proper use of vibrators.

The **water** used for concreting shall be free from all undesirable salts and other impurities and shall be fit for concreting as per IS : 456.

It is specifically being mentioned that the ground water available in this area may not be potable and not fit for concreting; therefore **transportation from nearby safe and acceptable water source has to be made**. For the purpose of concreting and curing only potable water conforming to provisions of IS: 456 is to be used. For this purpose

contractor shall make a temporary masonry/RCC **underground water reservoir** of 3 days average water consumption storage capacity. He shall provide a diesel **pump set** and necessary **pipng arrangement** to ensure proper curing.

The exposed surface of concrete shall be kept continuously in a wet condition by pounding or covering with a layer of sackings, canvas, hessain or similar materials and kept continuously wet for at least 28 days from the date of placing of concrete.

To obtain a dense concrete and to reduce chances of honeycombing adequate **admixture** approved by Engineer-in-Charge shall be used e.g. integral water proofing compound in concrete work. The quantity of the admixture shall be as prescribed by the manufacturer and as approved by the Engineer in Charge.

The aggregates and cement shall be proportioned by weight only. The mixing shall invariably be carried out in mechanical mixer and in such a way so as to avoid any loss of water or cement. No hand mixed concrete will be allowed. It should be conveyed, placed in position and compacted by suitable type of mechanical vibrator as rapidly as practicable but in no case the time of compaction after mixing shall increase 30 minutes. Standby Concrete Mixer and Vibrator shall be available at Site.

The concrete shall be cured properly by keeping it moist constantly until end of three weeks from the date of casting.

Testing

Materials and workmanship shall comply with the relevant specifications as described in subsequent clauses and in the Rajasthan PWD (B&R) Specification and RUIDP specifications. Any material or workmanship not covered by the above specifications shall comply with the relevant Indian Standard (with up to date amendments).

Material

The Contractor shall submit to the Engineer-in-Charge or his representative, samples of the materials which will form part of the permanent works, sufficiently in advance of the start of the work, so that necessary tests can be carried out for the approval of the Engineer In Charge or his representative, before using any such material on site. Samples for the basic materials shall be submitted from every supplier and from each consignment; if materials differ from one consignment to another, the consignment differing from the accepted sample shall be replaced by the Contractor free of cost. The format will be provided by Engineer In Charge.

The testing of materials to be used in the Works, or of the quality of finished items shall generally be done in a laboratory approved by the Engineer-in-Charge or his representative. All testing charges shall be borne by the Contractor. The following tests shall be carried on a routine basis:

- (a) Gradation and specific gravity of coarse and fine aggregate to be used for concrete work.
- (b) Moisture content in fine and coarse aggregates, bulking of sand of fine aggregate.
- (c) Determination of fines and deleterious materials, organic impurities and light weight places in coarse and fine aggregate.
- (d) Workability tests on concrete by means of slump cone.
- (e) Determination of the crushing strength, absorption and efflorescence of bricks.
- (f) Concrete cube crushing strength at 7 days and 28 days.
- (g) Determination of flakiness index and crushing value for coarse aggregates.

The above tests (a) to (g) inclusive, shall be done on a routine basis as per the provisions of the relevant Indian Standards, or as specified by PMC and explanatory notes shall be kept during the construction period. The following additional tests of materials and workmanship shall also be carried out at contractor's cost, if the Engineer-in-Charge or his representative requires:

- (h) Chemical tests of fine and coarse aggregates, to determine the sulphate, chlorides and other deleterious material present in the aggregate.
- (i) Testing of cement (Physical and Chemical), as per IS 269 or IS 485, as the case may be.
- (j) Tests on steel (Mild and High Tensile (Tor) as per IS 1786 to establish the Ultimate tensile strength, yield stress, percentage elongation and chemical composition.
- (k) Tests for suitability of water for concrete work.

In addition to the above tests, the Engineer In Charge or his representative, may request any other test to be carried out from time to time as per the Indian Standards or the Rajasthan PWD specification, at contractor's cost.

Concrete

During the progress of construction sampling, preparation of test specimens, curing and testing of concrete shall be conducted in accordance with IS 1199 and IS 516, to determine whether the concrete being produced complies with the strength requirements as specified.

At least one slump test shall be carried out for every compressive strength test carried out, or as directed by the Engineer in Charge. Six numbers 15 cm cubes shall be made for each cubic meter or portion thereof or for each pour per grade of concrete. This number may be increased at the discretion of the Engineer-in-Charge. Six specimens shall preferably be prepared from different batches, three being tested after 7 days and the remaining three being tested at 28 days. The Contractor shall provide, at his own expense, all apparatus, labour and arrange for testing at a laboratory, approved by the Engineer in Charge.

The concrete tested in accordance with “Testing of Concrete” clause above, shall be the criteria for acceptance of concrete as per IS 456. The strength of concrete shall be the average strength of three specimens tested at 28 days and conform to strength requirements for different grades of concrete. If the advance 7 days tests show crushing strengths that are too low, corrective measures shall be taken at once, at the Engineer’s direction, without waiting for the results of the 28 days tests.

Failure to Meet Strength Requirements

In cases where concrete tested fails to meet the test requirements, the Engineer-in-Charge shall have the right to require any one or all the following additional tests. These shall be carried out by contractor at his own expense. The Engineer-in-Charge shall be the finally authority for interpreting the results and shall decide upon the acceptance or otherwise.

- Curing and load testing of the concrete member concerned represented by the test which failed.
- Replacement of any such portions of the structure. No payment shall be made for the dismantling of the concrete, relevant form work, or reinforcement. Embedded fixtures and reinforcement of adjoining structures damaged during dismantling shall be made good by the contractor at his own expense.

- Extended curing of the structure of the concrete represented by the specimen.
- Collecting and testing of a core specimen from the hardened concrete. The location number and size of such specimen shall be taken as directed by the Engineer-in- Charge.
- Any Other tests i.e. ultrasonic/ or rebound hammer tests to be decided by the Engineer-in-Charge, at the contractors own cost.

Check of Reinforcement and Concreting

All reinforcement shall be got checked recorded prior to pouring of concrete, by a representative of the Engineer-in-Charge. Similarly, the entire concrete pouring work shall be done in the presence of an officer not below the rank of Junior Engineer or support engineer from the consultant. The contractor shall therefore, give a notice of a minimum three days to the Engineer-in-Charge or his representatives, such that the work can be checked by him or his representative. No work shall be covered before inspection and approval of Engineer-in-Charge.

Minimum Requirement for all reinforced or plain concrete structures

Cement concrete (plain or reinforced) shall comply with the requirement of specifications of Rajasthan PWD (B&R) Specification and RUIDP specifications except in so far as these are not altered or modified by specific stipulations as given in the specifications herein. The concrete grades to be used shall not be leaner than following:

Water bearing structure i.e. container, beam platform in the reservoir and roof.	M25
Other structural concrete	M25
Lean concrete in foundation	M15

- Minimum cement content of 360 kg/m^3 with maximum 20mm size downgraded coarse aggregates for M 25 grade concrete, whereas design mix has to be carried out for M25 and above grade.

- Approved quality water proofing compound (chloride free) shall be added during concreting of all water retaining structure, in the proportion specified by the manufacturer/as per design mix or up to 2%

(percent) by weight of cement.

- To check the fine cracks, fiber should be used as secondary reinforcement in the RCC as per manufacturer recommendation for water retaining members only.

Construction joints

As construction joints are weak in shear normally construction joints, if required, shall be provided in location where shear stress is minimum. However, construction joints should be avoided in the bottom slab of any structure. In the walls of vertical construction joints should be avoided to the maximum possible extent. In the event the Contractor solely for his convenience proposes construction joints in the bottom slab and or vertical construction joints in the wall of the water retaining structures, then the Contractor shall provide approved PVC water-stop of 230 mm width and 8 mm thick in all such joints. For the convenience of construction and to avoid segregation of concrete horizontal construction joints shall be provided in a planned way at a height not more than 2.0 M in case of approved admixture, at his cost, is used by the contractor in the concrete to increasing the workability of the concrete without affecting the designed water cement ratio. In case such admixture is not used the height of such cast shall be restricted maximum up to 1.5 M.

All such construction joints should be prepared properly like removing of all loose materials by wire brush and soaking with rich cement slurry mixed with approved water- proofing compound in prescribed ratio, before pouring next concrete. Next pour of concrete in any construction joints in water retaining structures should be within 24 hours of last pour.

Design Considerations:

Design Submissions

The contractor shall be responsible for the safety of structures, correctness of design and drawings, even after the approval of the same by Engineer-in-Charge. Complete detailed design calculations of foundations and superstructure together with general arrangement drawings and explanatory sketches of reservoir shall be submitted to the Engineer-in- charge for approval. Separate calculations for foundations or superstructures submitted independent of each other shall be deemed to be incomplete and will not be accepted by the Engineer-in-charge.

The design considerations described hereunder establish the minimum basic requirements of plain and reinforced concrete structures, masonry structures and structural steel works. However, any particular structure shall be designed for the satisfactory performance of the functions for which the same is being constructed.

Design Standards

All designs shall be based on the latest Indian Standard (I.S.) Specifications or Codes of Practice unless otherwise specified. The design standards adopted shall follow the best modern engineering practice in the field based on any other international standard or specialist literature subject to such standard reference or extract of such literature in the English language being supplied to and approved by the Engineer-in-charge. In case of any variation or contradiction between the provisions of the I.S. Standards or Codes and the specifications given along with the submitted tender document, the provision given in this specification shall be followed.

Design Life

The design life of all structures and buildings shall be 60 years.

Design Loading

The structure shall be designed to resist the worst combination of the following loads/stresses under test and working conditions; these include dead load, live load, wind load, seismic load, stresses due to temperature changes, shrinkage and creep in materials, dynamic loads:

Dead Load

This shall comprise all permanent construction including walls, floors, roofs, partitions, stairways, fixed service equipments and other items of machinery. In estimating the loads of process equipment all fixtures and attached piping shall be included.

Live Load

Live loads shall be in general as per I.S. 875. However, the following minimum loads shall be considered in the design of structures:

- i) Live load on roofs
: 4.00 KN/m²

- ii) Live load on all other floors walkways,

tairways and platforms

: 2.00 KN/m²

In the absence of any suitable provisions for live loads in I.S. Codes or as given above for any particular type of floor or structure, assumptions made must receive the approval of the Engineer-in-charge prior to starting the design work. Apart from the specified live loads or any other load due to material stored, any other equipment load or possible overloading during maintenance or erection/ construction shall be considered and shall be partial or full whichever causes the most critical condition.

Wind Load

Wind loads shall be as per I.S. 875. Part 3. The risk coefficient should be for important structure. Similarly terrain considered as few or no obstruction.

Earthquake Load

This shall be computed as per I.S. 1893 taking into consideration soil foundation system, importance factor appropriate to the type of structure basic horizontal seismic coefficient/ seismic zone factor & average acceleration coefficient. The zone for earth quake consideration shall be zone 3. If in the district, more than one zones have been specified in the new earthquake BIS code, the severest zone has to be considered for the analysis.

Joints

Movement joints such as expansion joints, complete contraction joints, partial contraction joints and sliding joints shall be designed to suit the structure.

Suggestive list of equipment required in the field laboratory at each Parking site

S.No.	Equipment	Min. Nos. Required.
1.	IS sieves with lid/pan: Size in mm: 100, 90, 80, 63, 53, 45, 37.5, 26.5, 19,13.2,11.2,9.5,4.75,2.8,5.6,3.35,2.36, 600 , 500, 425,355, 250, 212, 180, 150, 90, 75, 63,53,45,and 38 micron,	1 set
2.	Cube moulds 70 mm for mortar	6
3.	Cube moulds for CC 150 mm	6
4.	Compression testing machine 200t	1
5.	Electronic/digital balance 1 kg with least count of 0.01g	1
6.	Electronic / digital balance 5 kg	1
7.	Pan balance with weight box 5 kg.	1
9.	Oven (300oC) thermostatically controlled,	1
10.	Slump cone	1
11.	Vicat Apparatus	1
12.	Atterberg Limit Apparatus	1

Section-V : Procuring Entity's Requirements

INTRODUCTION

Udaipur Smart City Limited intends to develop a Smart City Infrastructure encompassing various ICT enabled functionalities which offers more reliable, convenient and hassle free services to its citizen in an effective and coordinated manner.

It has been observed that, Information and Communication Technology (ICT) has changed the evolution of cities; the notion of “growing” cities is being replaced with the idea of making a city “Smart City”. ICT has forced the think tank and compelling planners of the cities to not only consider the physical planning of a city but to also consider ICT enablement to make the economy, environment, mobility and governance more efficient and effective.

To build on these advances, innovative governments continue to seek new ways of maximizing business value; purchaser keens to take up an initiative for transforming Udaipur into a Smart City by embedding Smart sensors, devices, and actuators within physical space and infrastructures of the city. This offers real-time data management, alerts, and information processing for the city administration and thus allows city planners to develop other innovative ecosystems in line with its people through technology.

Udaipur Smart City Limited has identified the pan city area of 65 square kilometers to be developed as “Smart City” with state-of-the-art systems powered with Smart ICT interventions.

1 PROJECT PROFILE & BACKGROUND INFORMATION

The Udaipur Smart City Limited has a vision to combat and manoeuvre the growing requirements of a large city in wake of the increasing population and to help give the city a planned look compatible and comparable to any metropolitan city of repute. The Development authority intents to speed up the development and progressive growth of the entire city.

With the initiative of the e-governance projects the major work area is being rendered through IT based solutions. Many activities are now performed through IT support solutions and hence most of the city infrastructure is also needed to be run integrated with an integrated ICT platform.

The Udaipur Smart City Limited is committed to working for the benefit of the citizens of Udaipur with planned implementation of development schemes and is consistently striving to take it to higher levels of progress. To meet its objective, the team intends to provide, safety and security solutions, cost effective and easy access to information, Smart ways to manage various Citizen needs like parking, traffic management etc. through multiple devices and platforms.

The Udaipur Smart City Limited seeks to develop Smart City solutions and state of art City Operation Centre of the City, which will help to deliver smart city services.

The following Smart solutions have been included as part of Udaipur's smart city initiative:

1. Smart Parking

It is important to note that Smart City Network solution will help Udaipur city build a converged network, bringing together different city management vertical solutions on a single foundational network infrastructure. The converged network facilitates information exchange between resources and applications across different domains. It is an end-to-end open platform enabling IoT services for cities. Its key objectives are to provide:

- IP connectivity to things, people, devices, and vehicles in the city street
- Wired and wireless, scalable, and highly secure network platform
- A data management framework to help enable data collection, organization, and sharing
- Distributed compute and storage services, location services, and security services

2 SCOPE SUMMARY

Solution wise scope is summarized below:

The purpose of the Contract is the development of a project, which includes the provision, implementation of equipment and software components and all related works, as well as the professional services necessary to start and operate the Smart Parking as a part of Smart City initiative in the City Of Udaipur. The following elements are under the scope of this Contract:

- Provision, implementation of materials, instrumentation and software components and all related works, as well as the professional services necessary to start and operate the Smart Parking Solutions initiative in the City Of Udaipur. The software shall manage the parking locally in a pc and remotely in the cloud(private cloud of USCL). Each parking station should be able to communicate to the central server at DC through wireless/3G/Ethernet. The Parking management software has to provide Restful API to the database and the mobile application.

Furthermore the bidder will have to Maintain the Assets, thus created for Five (5) Years.

3 FUNCTIONAL REQUIREMENT OF PROPOSED SOLUTION

4.1 SMART PARKING SOLUTION

Udaipur Smart City Cooperation has envisioned the intelligent parking services that address city's parking issues through sensor-enabled parking management. This will enable citizens with real-time information about available parking and allows them to book spaces in advance using mobile applications. The results are less-traffic congestion and a more effective partnership of city with citizens, local businesses, and parking enforcing agencies. The solution should improve parking guidance, parking enforcement, and parking administration as well as provide parking occupancy, utilization revenue, and enforcement reports through analytics.

Smart parking solution should meet below functional requirement:

- a) The complete smart parking system should be able to handle pass system creating all types of passes – hourly/daily(08 hrs) pass, weekly pass and monthly pass with renewal facility
- b) The system should be able to create enforce dynamic pricing such as peak hour pricing, peak day pricing, peak season pricing etc.
- c) Capable of NFC based Pass system.
- d) The system should be able to work in offline mode as well along with online mode
- e) The system should have features such as real time reports for revenue management, provision to allow Govt. vehicles to park free of charge (in built in the system) and penalizing receipt in case of loss of parking token
- f) The bidder/consortium should have at least 1-year experience of running the systems
- g) The bidder/OEM should have a minimum of 30 such systems operational in the market
- h) parking management system integrated with each other
- i) The system should have provisions to accept one-city NFC cards for parking payments
- j) The consumer app should show availability of the parking slots, allow search, navigation and reserve/booking of parking. This system should be inbuilt and be available to the general public
- k) The Bidder shall develop the APIs to provide access to the raw data and all the analytical data of the City Management Application (Integrated IT Platform).
- l) The Bidder shall provide access to the development manuals with use example to facilitate the use and integration of the API of the Transport Management Software in other municipal services.
- m) The Bidder shall provide a web server to be accessible to the information from other servers
- n)

The identified locations for Smart Parking facilities are as follows:

S.No.	LOCATION	LATITUDE	LONGITUDE
1	SEWA ASHRAM CIRCLE (UNDER BRIDGE)	24°34'46.3"N	73°43'22.4"E
2	MANIKYA LAL VERMA GARDEN	24°34'08.3"N	73°41'08.9"E
3	TOWN HALL	24°34'57.3"N	73°41'50.4"E

4	LAKE CITY MALL	24°35'10.0"N	73°42'38.4"E
5	HATHIPOLE	24°35'12.1"N	73°41'14.8"E
6	SAHELIYO KI BADI	24°36'11.1"N	73°41'09.5"E
7	CHAND POLE	24°34'59.2"N	73°40'55.2"E
8	PALA GANESH JI TEMPLE (NEAR GULAB BAGH)	24°34'22.7"N	73°41'17.4"E
9	RAILWAY STATION	24°34'04.8"N	73°41'58.9"E
10	ROADWAYS BUS STAND	24°34'35.2"N	73°42'03.3"E
11	DURGA NURSARY ROAD	24°34'58.6"N	73°42'33.6"E

Functional Requirement of Smat Parking:

1. Entry Requirement

- i. Entry to any parking space should have outdoor displays/screens showing overall availability of parking slots in that particular parking space.
- ii. Each entry lane should be equipped with one Entry Device with the following capabilities:
 - a) The Entry Device should act as an Automatic Ticket Dispenser
 - b) It should have touch screen/push button for motorist to enter Unique Booking Number
 - c) The Entry Device should have Near Field Communication (NFC) capability
 - d) The Entry Device should have capability to connect with Intercom, microphone, speaker and other subsystems
- iii. The ticket, QR Code and Smart Parking Card or any other technology used by SI should be capable of capturing data that is easily retrievable at the exit.
- iv. Every vehicle entering the parking space should be stopped by barrier. The barrier is raised when the motorist is issued a ticket or has been identified as a legitimate user.
- v. In case the parking lot is already occupied to its capacity, the ticket issuing should automatically be blocked and therefore, the barrier should not open. A message should also be displayed on the outdoor screen stating the same.
- vi. The Entry Device should be able to detect and report :
 - a) Anti-pass back
 - b) Back-out ticket
 - c) Low ticket stock
- vii. The display on Entry Device should have capability to display messages in English, Hindi and other Regional languages.

-
- viii. The solution should also include provision to capture the image of vehicle and license plate number of every vehicle entering any of the parking spaces using dedicated cameras.

2. Exit Requirements

- i. Any vehicle, before leaving the parking area, should be stopped by a barrier system at the point of exit from the parking.
- ii. The solution should have clearly instructed easy to use interface
- iii. The solution should also include provision to capture the image of the vehicle including license plate number exiting any of the parking spaces and the all the information related to the same should be stored at a central server.
- iv. Manual Pay Station:
 - a) Exit of every parking should be equipped with a manned Pay station (booth).
 - b) The exit booth should have appropriate space for keeping devices such as a computer with internet connectivity, QR code reader, credit card reader, printer etc.
 - c) For motorists who enter the parking lot using Smart Parking Card, Monthly pass or any other NFC capable card provided by SI, the exit booth should also have NFC facility for motorist to tap his/her Smart Parking Card for express exit. The payment can also be linked to the e-Wallet of the motorist with auto-debit option and corresponding limits and alerts to the same.
 - d) The personnel monitoring the exit Pay Station is also required to manually enter the License number details in the system so that the license number, along with date and time of exit, is stored in the database.
 - e) The payment for parking should be collected based on entry time stamp by any personnel stationed at the Pay Station.
- v. Once the vehicle exits a parking lot, the availability of total parking available in that parking space should automatically get updated.
- vi. Only after completing the full cycle correctly the transaction will be considered as valid within the car park. However, audit trail of each complete, incomplete and cancelled transaction should be available in the system.
- vii. The solution should be equipped with Anti-pass back technology and be able to detect and report any instance pass back.
- viii. The solution should allow full integration of third party devices with the Parking Management and Guidance System, and capture all transactions to generate customized reports.
- ix. The solution should track each and every revenue source and should ensure no

leakages due to manual intervention.

- x. The Pay Station should be capable of charging devices.

3. Entry and Exit Barrier

- i. The entrance and exit of each parking lot should have a barrier gate system using technologies such as boom barriers, bollards etc.
- ii. The barrier should remain in open position for optimal period of time for the vehicle to pass at entrance and exit.
- iii. The solution should also include provision to capture image of vehicle including license plate number of every vehicle entering and leaving any of the parking spaces and the all the information related to the same should be stored at a central server and can be used with Police surveillance system .
- iv. Barrier should have capability of in built glowing direction signage
- v. Barrier Arms should have the following options:
 - a) In closed position the full arm should be illuminated red.
 - b) During movement the full arm should be illuminated yellow.
 - c) Once reached open position the full arm should be illuminated Green.
- vi. Upon horizontal impact by a vehicle, the barrier arm should get detached from the barrier unit with minimal damage to the vehicle and the barrier motor mechanism. An alarm should also be raised and sent to the server and monitoring console, when the barrier is detached.
- vii. An alert should be sent to the console and server to ensure that the administrator is informed that the barrier is not attached or barrier breakage.
- viii. All vehicular passages during the time that the barrier is not attached should be recorded and displayed in the reports separately in order to audit the necessary revenue transactions during that time.
- ix. Upon impact during closure, the arm will stop and stay in the same position. Under no circumstances should the arm re-open upon impact. This is to prevent keeping the arm open for illegal entries or exits.
- x. The barrier arm should be easy to refit with barrier unit in a short duration (within one minute).
- xi. If for any reason and external override (fire system) needs to be connected, then this should only be possible over the Entry/exit Device and the switch should be permanently monitored by the Parking Management System.

B. Integration Scope

Below is high level indicative integration scope for current project, Bidder need to provide information as per API availabilities form various systems;

1)	Sensor Based Smart Parking	<p>a) Consolidates all city parking information onto a single operations platform.</p> <p>b) Should provide parking availability, revenue collection information on dashboard, which receives from various sources.</p> <p>c) The platform should be able to integrate any type of parking sensor irrespective of the technology used. For example, some parking sensors might use RF technology like LoRa or ZigBee to communicate the data and events, some might use GPRS or some might use Wi-Fi. Some parking sensors might use infra-red based detection; some might use magnetic field based detection or combination of the both where as some might use a video camera to detect parking occupancy. Irrespective of the technology, the platform should be able to integrate with these devices and their software managers and provide the data from such devices in a normalized and standard based data models.</p> <p>Automatic Number Plate Recognition</p> <p>Bidder should integrate Automatic Number Plate Recognition (ANPR camera at parking lots with the ANPR solution implemented by police department</p> <p>All ANPR cameras shall provide the feed to the command control center,</p> <p>The ANPR system shall provide a user interface with live view of vehicle entry point 24x7, event notification, image captured, number detection and recognition, event reports customized report generation etc.</p> <p>The analysis of the image captured shall be done in real time. The database so created from the images captured & analysis shall store the following:</p> <ol style="list-style-type: none"> 1. Details of vehicle 2. Number and time of entries and exits 3. License plate numbers 4. Validation/Analysis results etc.
----	----------------------------	--

10.0 Scope of Work

The basic outline of scope of work to be undertaken by the bidder for setting up and operating of Smart Parking Solution is mentioned in the following documentation.

- Installation of Loop Sensors which includes cutting the loop slot using using an angle grinder with a masonry disc.

-
- Laying the loop cable in to the slot. Once the cable has been laid and the installation tested the slot is sealed using hot pour bitumen mastic, an epoxy compound or commercial loop sealant. Materials without waterproofing properties, are not acceptable substitutes for slot sealing. It is vital to ensure the slot is well packed with the sealant to prevent water ingress.
 - Construction of Operator Room (Porta Cabin) at exit point, design needs to approved by EIC.
 - Installation of Ticket Vending Machine, Boom Barrier, Display at entry, ANPR camera etc.
 - The selected bidder shall plan & design the solution to ensure an uptime of 99.749% on a quarterly (monthly) basis.

For detailed requirement specifications for each of the Smart components, application platform , please refer the Bill of Materials and Technical specifications

10.1 POC/ Client Visit, Supply, Installation and Commissioning Phase

Proof of Concept/Client Visit

The Proof of Concept (PoC) will be evaluated along with presentation to be given by bidders:

1. Each shortlisted bidder for Technical Evaluation shall demonstrate the PoC/Client Visit.
2. The Bidder is expected to demonstrate for complete Scheme as per RFP either in PoC or a Live Location:
 - i. Integration of hardware and software and functioning of the same simultaneously;
 - ii. Interface with each other on a common communication platform
 - iii. The demonstration should provide a representative solution to integrate various aspects of the project as per the scope
3. The Bidder is expected to bear the cost of demonstrating the PoC and would also be responsible for making the demonstration in India.
4. PoC shall be demonstrated in English.

USCL may visit various client sites (national) to validate the project citations and implementation experience quoted by the bidder. The bidder is expected to bear all the expenses and facilitate for the same

- Commissioning & Acceptance Testing shall involve
 - Successful installation of the all Smart Components, availability of the application and integration to the CCC platform
 - getting the acceptance of the same from USCL.

a. Supply, Installation and Commissioning of Non IT Components

- The selected bidder shall procure and supply all Non IT components.
- Installation shall mean to install and configure / integrate every component and subsystem component, required for functioning of the application.
- Based on generic solution design, minimum capacities and specifications for the components have been worked out and described in the section for specification .
- It may be noted that these are only bare minimum requirements and the Bidder is at liberty to suggest better solutions to meet the overall SLA requirements.

b. Supply, Installation and Commissioning of IT Components

- The selected bidder shall procure and supply all IT (Active and Passive) components. The selected bidder would be required to undertake all the necessary works related to installation of all the components.
- Installation shall mean to install and configure / integrate every component and subsystem component, required for functioning of all Smart Components.
- Based on generic solution design, minimum capacities and specifications for the components have been worked out and described in BOQ and specifications.
- However, these are only bare minimum IT requirements and specifications and the Bidder is at liberty to suggest better solutions to meet the overall SLA requirements

All Non-IT and IT Components as specified in the BoM in the RFP document, as well as all additional infrastructure required for complete functionality of the Smart Components are to be brought by the bidder for the smooth running.

c. Acceptance Testing and Commission

- The BIDDER would be required to submit a detailed Final Acceptance Test (FAT) Plan while the installation of both IT & Non-IT components of the Smart Solution Component is in progress.
- USCL shall review and confirm the detailed final acceptance test plan (FAT) in consultation with the Smart City Consultant.
- USCL would also conduct audit of the process, plan and results of the Acceptance Test carried out by the Bidder. USCL would issue certification of completion for which USCL shall verify availability of all the defined services as per the Smart application platform as per the contract signed between the BIDDER and USCL.
- The BIDDER shall be required to demonstrate all the services / features / functionalities as mentioned in the Smart City application platform through a simulated test setup .
- Testing and Commissioning shall be carried out before the commencement of Operations.

d. Final Acceptance Testing

- Detailed test plan shall be defined by BIDDER . This shall be submitted by BIDDER to USCL while the IT & Non-IT installation is in progress.
- During implementation, bidder is requested to complete the Non-IT infrastructure first and submit the test plan for Non-IT infrastructure. Once Consultant clears the PAT for Non-IT components, bidder will deliver the IT components and start implementing the same.
- All documentation related to Smart Components and relevant acceptance test document (including Smart Components, Sensors, Applications, Non IT Components etc.) should be completed & submitted before the final acceptance test to USCL.
- The training requirements as mentioned should be completed before the final acceptance test.
- Successful hosting of the Smart application at CCC.

-
- For both IT & Non-IT equipment's / software manuals / brochures / Data Sheets / CD / DVD / media for all the USCL supplied components should be submitted to USCL
 - All hardware and software items must be installed at site as per the specification.
 - Availability of all the defined services shall be verified.
 - The BIDDER shall be required to demonstrate all the features / facilities / functionalities as mentioned in the RFP on the Smart Application platform
 - The BIDDER will arrange the test equipment required for performance verification. All test equipment should be readily available with the BIDDER once the go-ahead for the FAT is given by USCL.
 - In case any clearances for bringing the test equipment on board are required by the BIDDER, the same shall be obtained beforehand so that no delay in FAT initiation is observed.
 - At the time of FAT, warranties of all the products would be checked, warranty/AMC should be there for 5 years, and should be renewed as needed.
 - The cost for maintaining warranty or AMC for hardware and renew of support from OEM shall be borne by BIDDER .
 - The final acceptance shall cover 100% of the Implementation and operational of all Smart Parking and integrated with Command and control Centre application, after successful testing by USCL or its third party monitoring agency

10.2 Operation and Maintenance Phase

The scope of work for the Operations phase can be categorized under three service categories as depicted in the figure below. Basic Infrastructure Services are mandatory services to be provided by the BIDDER to ensure the specified smart element functionality.

a. Readiness for the Services

- BIDDER and USCL should agree upon the contractual period & service levels for providing the necessary services.
- Servers, necessary OS & other software, Database Licenses and other infrastructure over and above the BoM provided in this RFP, necessary for hosting application(s) would be provided by BIDDER for 5 years

b. AMC Services

Following services shall be provided by the BIDDER under the AMC services:

- Proactive and reactive maintenance, repair and replacement of defective components (physical and other peripheral IT infrastructure) installed through this RFP. The cost for repair and replacement shall be borne by the BIDDER.
- Any component (Physical & IT installed at the time of commissioning) that is reported to be faulty / non-functional on a given date should be either fully repaired or replaced by temporary substitute (of equivalent configuration) within the time frame agreed upon in the Service Level Agreement (SLA).
- Proactive monitoring of the entire basic infrastructure installed at the different locations.
- BIDDER shall maintain records of the maintenance of the basic infrastructure and shall maintain a logbook on-site that may be inspected by the USCL at any time.

c. Integration Testing

- Integration testing is essential to ensure that all solutions offered here in as part of Smart Components should work seamlessly with Smart City application at the CCC.
- The technical tasks to be carried out shall be as follows:
 - **Functional Testing:** Ensuring that all components and their applications functionality as described by the department works adequately on the CCC environment. The definition and review of the parameters for functional testing shall be the responsibility of the concerned department,
 - **Performance Testing:** Ensuring that the application meets expressed performance requirements by using performance test tools and performance monitoring tools. The definition and review of the parameters for performance testing shall be the responsibility of the BIDDER and the Composite Team respectively.
 - **Security Testing:** Testing for exploitable application security weaknesses that undermine the application security or the security of the infrastructure. The definition and review of the parameters for security testing shall be the responsibility of the BIDDER and the Composite Team respectively.

Centralize Control system for Parking management:

- Real Time Field Device Monitoring
- Revenue Generation Report
- Revenue Survey Report
- Survey Reports and statics
- Daily, Weekly and Monthly Reports.
- Daily Vehicle Count.
- Daily Vehicle Flow rate
- Vehicle wise daily movement details
- Parking Survey
- Event and Log Management
- Alarm Management
- Card/TAG Registration
- Password Protected Login

d. Reports

BIDDER shall submit the reports on a regular basis in a mutually decided format. The following is only an indicative list of MIS reports that may be submitted to the State:

- **Daily reports**
 - Summary of issues / complaints logged at the Help Desk
 - Summary of resolved, unresolved and escalated issues / complaints
 - Summary of resolved, unresolved and escalated issues / complaints to vendors.
- **Weekly Reports**
 - Issues / Complaints Analysis report for virus calls, call trend, call history, etc.
 - Summary of systems rebooted.
 - Summary of issues / complaints logged with the OEMs.

-
- **Monthly reports**
 - Component wise physical as well as Application availability and resource utilization
 - Consolidated SLA / (non)- conformance report.
 - Summary of component wise uptime.
 - Log of preventive / scheduled maintenance undertaken
 - Log of break-fix maintenance undertaken
 - **Quarterly Reports**
 - Consolidated component-wise physical and IT infrastructure availability and resource utilization.
 - **Half- yearly Reports**
 - Firmware Upgrade / Obsolescence Report
 - **Incident Reporting**
 - Software license violations

10.3 Project Execution Timelines

Sl. No	Mile stone	Time Line
1	Implementation of 11nos. of Smart Parking Lots	90 days from date of handing over of parking sites
2	Smart parking application development as mentioned in RFP	90 from the date of award of contract.
10	Integration all smart components and their application to CCC application	180 days from the date of award of contract.

Indicative Picture of Parking Lot (Actual Design may differ depends on filed condition)

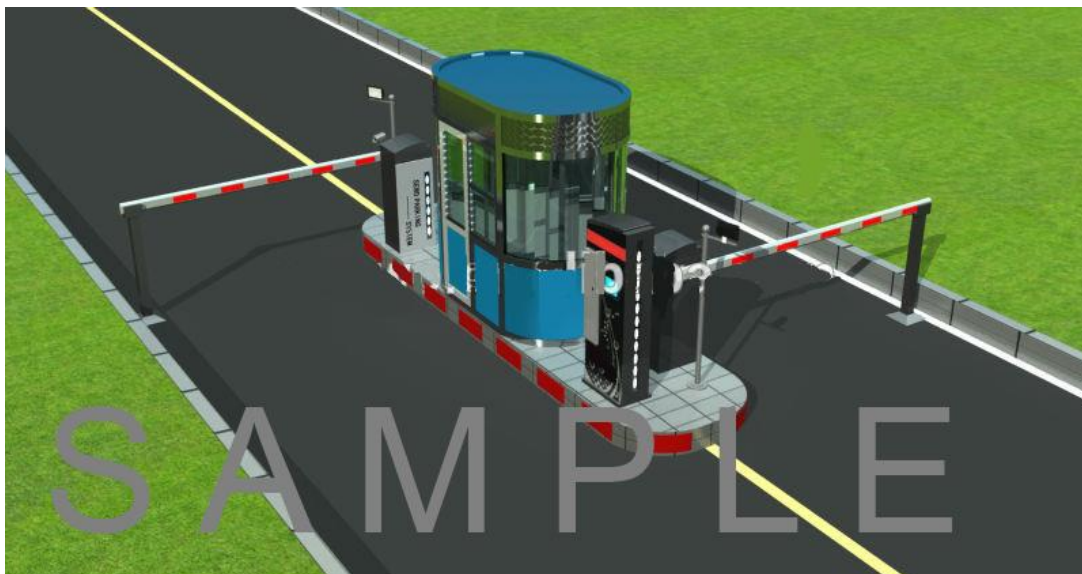
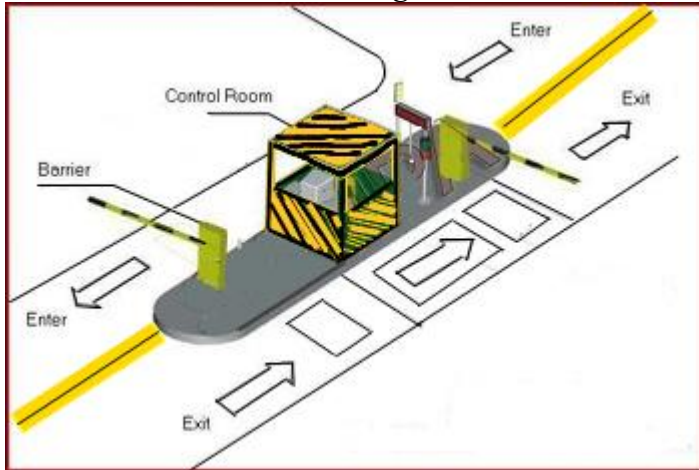

Sensors Installation:

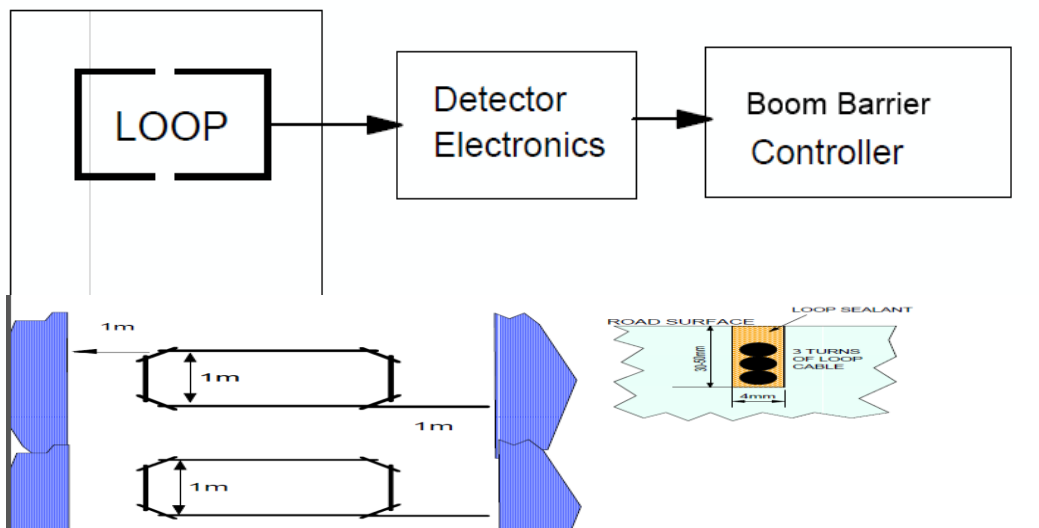

11.0 COMPLIANCE CHECKLISTS

11.1 Compliance and Specification Checklist for Smart Parking Solutions

ANPR Camera

Sr No	Minimum Specifications	Complied
1	IP 2 Mega pixel outdoor IR camera	
2	Image sensor	
3	Total sensor pixels	Minimum 1396 x 1097
4	Power	
5	Power Supply	12 VDC
6	Power-over-Ethernet	48 VDC
7	Nominal Current Consumption	maximum 300 mA (12 VDC) Maximum 75 mA (PoE 48 VDC)
8	Power Consumption	Maximum 12 W
9	PoE	IEEE 802.3af (802.3at Type 1) Power level: Class 1
10	Video performance	
11	Sensitivity	Minimum Color 0.07 lx, Minimum Mono 0.05 lx
12	Dynamic range	76 dB Wide Dynamic Range (WDR)
13	Video streaming	
14	Video compression	At least H.264 (MP) and M- JPEG
15	Streaming	Multiple configurable streams in H.264 and MJPEG, Configurable frame rate and bandwidth.
16	Overall IP Delay	Minimum 120 ms, Maximum 340 ms
17	GOP structure	IP
18	Encoding interval	1 to 25 fps
19	Video functions	
20	Day/Night	Color, Monochrome, Auto
21	Adjustable picture settings	Contrast, Saturation, Brightness
22	White Balance	4 automatic modes, manual mode and measure
23	Contrast enhancement	On/off
24	Privacy Masking	Four independent areas, fully programmable
25	Video Analysis	MOTION+

26	Shutter	Automatic Electronic Shutter; Fixed shutter selectable; Default shutter	
27	Backlight compensation	On/off	
28	Noise reduction	Intelligent Dynamic Noise Reduction with separate temporal and spatial adjustments	
29	Sharpness	Sharpness enhancement level selectable	
30	Other functions	Image mirror, Image flip, Pixel counter, Video watermarking, Display stamping, Scene modes	
31	Input/output		
32	Alarm input	1 input with short or DC 5V activation	
33	Alarm output	1 output with input rating of Maximum 0.5 A, 30 VAC / 40 VDC	
34	Optical		
35	Lens mount	On Board mounted	
36	Lens type	Varifocal lens 3.3 - 12 mm, DC Iris F1.4 – 360, with IR corrected lens	
37	Horizontal field of view	Minimum 32° - 100°	
38	Vertical field of view	Minimum 18° - 53°	
39	Network		
40	Protocols	IPv4, IPv6, UDP, TCP, HTTP, HTTPS, DHCP, APIPA (Auto-IP, link local address), 802.1x, SMTP, iSCSI, UPnP (SSDP), Dropbox, CHAP, digest authentication, DNS, DNSv6, DDNS	
41	Encryption	DES, 3DES, TLS 1.0, SSL,	
42	Ethernet	Minimum 10/100 Base-T, auto-sensing, half/full duplex	
43	Connectivity	Auto-MDIX	
44	Interoperability	ONVIF Profile S and /or GB/T 28181	
45	Software		

46	Unit Configuration	Viewing Via web browser or Configuration Manager	
47	Firmware update	Remotely programmable	
48	Software viewer	Web browser or third party software	
49	Environmental		
50	Operating Temperature	Minimum -30 °C to +60 °C maximum	
51	Storage Temperature	Minimum -30 °C to +70 °C maximum	
52	Humidity	Minimum 20% to 90% relative humidity (non-condensing)	
53	Certifications and approvals		
54	Standards	EN 50130-4 EN 60950-1 EN 50130-5 Class II EN 55022 class B EN 55024 cUL 60950-1 ICES-003 Class B VCCI J55022 V2/V3 EN 50121-4 CAN/CSA-C22.2 NO. 60950-1-07 C-tick AS/NZS CISPR 22 (equal to CISPR 22) (Certification to be provided for each of the above)	
55	ONVIF conformance	EN 50132-5-2;IEC 62676-2-3	

Parking Display

S. No.	Parameter	Min. Requirement
1	Estimated LED Life Span	Minimum 100,000 hours
2	Pixel	Each pixel make up by 3 in one SMD
3	Pixel Pitch	6mm
4	Regulatory Certifications	CE, FCC,UL
5	Consumption W/m2	750 Max and 250 Typically
6	Ambient Temperature	-200 C ~ 500 C
7	Ambient humidity	10% ~ 99%
8	Display Resolution	160 pixels x 200 pixels
9	Display size	W 960mm * H 1200 mm

10	Ingress protection	IP65 Front and IP54 rear
11	Power supply	100~240 V AC 50/60 Hz
12	Colours	281 Trillion
13	Brightness	5000 Nits or higher

Ticket Dispensing Machine

Parameter	Min. Requirement
Printer	Integrated thermal with graphics capabilities, 18 lines per second, 22, 32, or 42 columns; 40mm paper roll
Paper	40mm roll: Length: 163mm; Max Width: of 78mm;
Ingress protection	IP65
Power supply	110 ~ 240 Voltage
Push Button	Contact closure/open on press
Environmental	0°to 50°C (32°to 122°F) operating temperature: 5% to 90% relative humidity, non-condensing Storage temperature: -20° to 60° C / 5% to 90% RH; non-condensing

Boom Barriers

Parameter	Min. Requirement
Length of the beam with both straight and articulated options	3.5 meter
Max opening time	2 sec
Max closing time	2 sec with programmable option
Duty cycle or % Use frequency	Greater than 70 %
Power Unit	Electro-mechanical
Power Consumption Max.	30 W
Controller board interface	NO/NC / TCP/IP
Sensing	Photocell based optical sensing and magnetic loop detector
MCBF(Mean cycle between failure)	8000000 with 3 rd party certification
Input power supply	230 V AC ± 10%, 50/60 Hz
Ingress protection class	IP 54
Operating temp	-20 to + 55 Deg C
Beam type	round or rectangular or octagonal
Security	Door with security lock
Manual override	Automatic barrier unlocking device in case of power failure. Opening should be possible by hand as well.
Safety feature while car under the barrier closing s	Reverse on contact or non-contact sensing mechanism, Auto sway away feature

Operator Console (Entry/Exit)

Parameter	Min Requirement
OS	Windows/Linux
HDD	500GB
RAM	4GB
CPU	Intel i3 3.2Ghz
Display	19" LCD Display
Keyboard	Standard 104 key Keyboard
Mouse	USB Mouse (Optical)
Barcode Scanner	As required by Proposed solution
Cash Drawer	As required by Proposed solution
Proximity Card reader	As required by Proposed solution
Image Processing Card	As required by Proposed solution

12.0 PREAMBLE TO BILL OF QUANTITIES & PRICES

12.1 Introduction

- A) The bidder shall quote his offer/rates for the work under this package in the BOQ downloaded from web site only and rates quoted on other BOQ or on old BOQ (if any) shall not be considered. The bidder are advice to up load the financial bid on latest BOQ downloaded from Web site.
- B) Unless stated otherwise, all rates entered in the Bill of quantities shall be deemed to include the following:

-
- Labour and all costs in connection with the execution, completion, testing and commissioning of the work.
 - The supply of materials, goods, storage and all costs in connection there with including wastage, shrinkage and delivery to Site.
 - Item of Excavation, Dismantling of Bituminous & Granular Courses & CC pavements and Road Restoration and no allowance will be made for wastage, working space, bulking or shrinkage, overlaps, re-handling and the like.
 - Plant, equipment and all costs in connection therewith.
 - Sampling and testing materials and goods, testing workmanship, providing, storing, packing and transporting samples to and from the place of testing.
 - Fixing, erecting, installing or placing of materials and goods in position.
 - Disposing of surplus and unsuitable materials and goods and excavated materials, including stacking, storing, loading, transporting and unloading.
 - All Temporary Works
 - Construction and maintenance of temporary access roads within the Site and of any roads required for access to any part of the Site for the purpose of carrying out the Works, taking into account that the access roads under the Contractor's maintenance control will also be used by the Procuring Entity and his staff's vehicles.
 - Construction, maintenance and removal, if required, of temporary Site drainage on the Site, and for ensuring that all drains are kept clear of debris and blockages at all times.
 - All general obligations, liabilities and risks involved in the execution and maintenance of the Works set forth or reasonably implied in the documents on which the Tender is based.
 - Establishment charges, overheads and profits.
 - Co-operating with other contractors if required.

12.2 General

- (a.) The Bidder shall be deemed to have read and examined the Tender Documents before quoting the item rates as per TD in BOQ. The Drawings, Specifications, Schedules etc. are to be considered as explanatory of each other and no advantage shall be taken of any omission in tender documents.
- (b.) The Bidder shall be deemed to be fully conversant with and to have made full allowance in his Tender for the site conditions, the nature and complexity of the work to be undertaken, the other extensive development and construction work currently being or which may be executed on and around the Site and all changes in the nature and condition of the Site from that existing at the time of Tender.
- (c.) The rates quoted in the schedule shall be the all inclusive value for the work described in tender document and be deemed to include for all the Contractor's liabilities and obligations and all risks set forth or implied in the document and all matters and things necessary for the proper construction, of the Works including setting out, plant, labour, supervisor, materials, erection, power consumption, maintenance, insurance, profit, taxes and duties together with all general risks liabilities and obligations set out or implied in the Contract for construction and operating period.
- (d.) Disposal of all excavated material shall be including of all lead and lift and re-handling to disposal point as directed by EIC.
- (e.) Items Incidental to Work:

(f.) Following is the list of items incidental to work which are to be executed by Contractor but no separate payment shall be made. This also includes any material, equipment, appliances and incidental work not specifically mentioned herein or noted on the Drawings/Documents as being furnished or installed, but which are necessary and customary to be performed under this contract. The cost of such items shall deem to have been included in other BOQ items.

Sl No	Items Incidental to Work
(i)	All site surveys and civil investigations
(ii)	All constructions designs and drawings
(iii)	All built drawings
(iv)	All designs and changes to software to match requirements
(v)	Project Staff and manpower
(vi)	Project Office and expense thereof
(vii)	Safety and medical costs of their employees
(viii)	Environmental and social safeguard compliances
(ix)	Any other item necessary and customary to be performed under this contract

13. Indicative Minimum Bill of Materials

The bidder should ascertain, mention and include the cost of all and not limited to the following -accessories/components/hardware/firmware/software/APIs/ Media Convertors etc which would be necessary to make the solution implemented as per the functional, technical requirements and integration into the City Command and Control Centre. The quantities mentioned are only indicative and may vary as per the solution and platform provided by the bidder or the requirements of USCL, where ever exact quantity is not specified the bidder should provide justification for the quantities decided by the bidder to match his solution requirement.

S.No	Solution	Unit	Indicative Quantity
Smart Parking Solution			
1	Operator Console at Entry/Exit gate.	Nos.	11
2	Parking Sensor (Bi-directional Loop Detector) (at Entry and Exit point only)	Nos.	22
3	Ticketing System Hardware (Entry)	Set	11
4	Display System (outdoor rated) at Entry Point	Nos.	11
5	Boom Barrie (Entry & Exit)	Nos.	22
6	Parking Management System		1
12	Passive components including required accessories etc for Smart Transport Solution	Nos	As Required
13	Passive components including Bandwidth solution and required accessories etc	Nos.	As Required
16	Installation Operations & Maintenance for IT / Non-IT Infrastructure for 5 <u>Years</u>	Nos.	As Required

** Quantity is indicated for bidding purposes. Will be ordered as per design by the bidder.

14.0 SERVICE LEVEL AGREEMENT

Service Level Agreement (SLA) shall be the part of contract between USCL and the successful Bidder. SLA defines the terms of the successful Bidder's responsibility in ensuring the timely delivery of the deliverables and the correctness of the same based on the agreed Performance Indicators as detailed in this section.

The successful Bidder has to comply with Service Levels requirements to ensure adherence to project timelines, quality and availability of services.

The successful bidder has to supply software / automated tools to monitor all the SLAs mentioned in the scope of work .

Penalties

Penalties shall not be levied on the successful Bidder in the following cases:

- There is a force majeure event effecting the SLA which is beyond the control of the successful Bidder. The non-compliance to the SLA has been due to reasons beyond the control of the bidder.
- Theft cases by default would not be considered as “beyond control of the bidder”. However,
- certain cases, based on circumstances & certain locations, police may agree to qualify as “beyond control of the bidder”.

- Damages due to Road Accident / Mishap shall be considered as “beyond the control of bidder”.
- However, Power shut down or deliberate damage to Pole /Equipment/Sensors would not be considered as “beyond control of the bidder”.

This SLA document is to clearly define the levels of service which shall be provided by the System Integrator to USCL for the duration of this contract.

Definitions for availability

Uptime shall mean the time period for the specified services / components with the specified Functional and technical requirements stipulated are available to the user department.

$$Uptime = \{1 - \text{Downtime} - \text{Planned Maintenance time}\} / (\text{Total Time} - \text{Planned maintenance time}) * 100$$

Downtime shall mean the time period for the specified services / components with the specified Functional and technical requirements stipulated are not available to the user department. and excludes downtime owing to Force Majeure & Reasons beyond the control of bidder .

Planned downtime would not be included in the calculation of application /service availability. However, the Successful Bidder should take at least 10 days prior approval from USCL in writing for the planned outage, which should not be for more than 12

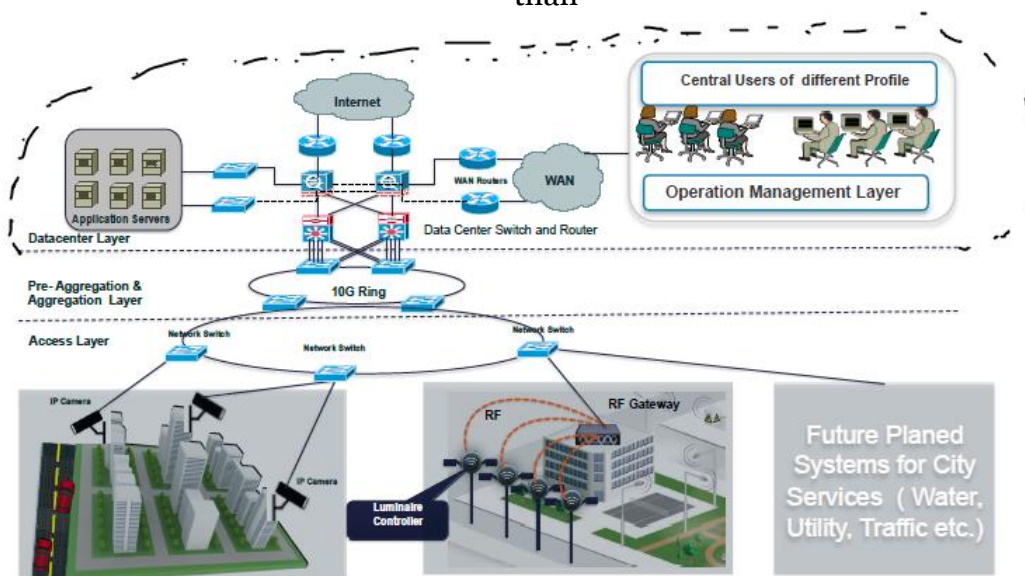

0 minutes, would be in lean period (non-movement period, like post mid-night) and limited to max. 4 outages in a year

Incident refers to any event / abnormalities in the functioning of those defined services that may lead to disruption in normal operations

Resolution Time shall mean the time taken (after the incident has been reported at the helpdesk), in resolving (diagnosing, troubleshooting and fixing) or escalating (to

the second level or to respective Vendors/OEMs , and raising a child ticket for the OEM, and closing the same subsequently .

SLA Metrics and Payment

- The SLA metrics provided specifies a baseline performance of Service availability.
- There are multiple slabs for Service Levels which relate to certain definite percentage of Penalty.
- The Agency will get 100% of the contracted value if the all baseline performance metrics are complied.
- The Agency will get lesser payment in case of the lower performance as indicated in the SLA matrix .
- SLAs will be evaluated on a Monthly basis unless specified otherwise.
- If the performance of the Agency in respect of any parameter falls below the prescribed lowest permissible limit specified , then under certain conditions the contract itself may be terminated.
- Appropriate SLA Measurement tools to be are to be provided by the SI and audited by USCL or its appointed Consultant for accuracy and reliability.
- It is the responsibility of the System Integrator would to configure the SLA Measurement Tools such that all the parameters as defined under SLA matrix given can be measured and appropriate reports be generated for monitoring the compliance.
- The SLAs defined, shall be reviewed by USCL on an annual basis after consulting the SI(System Integrator)/Successful bidders , Project Management Consultants and other experts for correcting unrealistic metrics and penalties.
- USCL shall also have the right to conduct, either itself or through any other agency as it may deem fit, an audit / revision of the SLA parameters in consultation with the bidder.
- Total penalty to be levied on the SI shall be capped at 25% of the total contract value.
- USCL would have right to invoke termination of the contract in case the overall penalty equals 20% in two consecutive months.

Section VI-A: General Conditions of Contract

Section VI A: General Conditions of Contract

Table of Contents

1. General Provisions.....	
1.1	Definitions
1.2	Interpretations
1.3	Communications.
1.4	Law & Language
1.5	Works to be Carried out
1.6	Sufficiency of Tender/Bid
1.7	Discrepancies and Adjustment of errors
1.8	Signing of Contract.
1.9	Personnel.
1.10	Procuring Entity's Risks.
1.11	Contractors Risks
1.12	Procuring Entity's use of Contractors document
1.13	Contractor's Use of Procuring Entity's Documents.
1.14	Care and Supply of Documents
1.15	Delay in issuing Drawings or Instructions
1.16	Confidential Details.
2. The Procuring Entity	
2.1	The Procuring Entity /Procuring Entity.
2.2	Access to Site.
2.3	Assistance by Procuring Entity
2.4	Procuring Entity's / Personnel.
2.5	Procuring Entity's / Claim.
2.6	Quality Control.
3. The Engineer-in-charge.....	
3.1	Duties and Responsibilities
3.2	Delegation by Engineer-in-charge
3.3	Instructions of the Engineer-in-charge
3.4	Replacement of Engineer-in-charge
3.5	Determinations
3.6	Minutes of Meeting
4.The Contractor.....	
4.1	General Obligations
4.2	Compliance with the code of Integrity
4.3	Performance Security
4.4	Commencement of Works at the earliest
4.5	Contractor's Representative
4.6	Subcontractor
4.7	Co-Operation
4.8	Safety Procedures at the site of work

- 4.9 Quality Assurance
- 4.10 Site Data
- 4.11 Sufficiency of the Contracted Amount
- 4.12 Unforeseeable Physical Conditions
- 4.13 Rights of Way and Facilities
- 4.14 Avoidance of Interference
- 4.15 Access Routes
- 4.16 Contractor's Equipment
- 4.17 Protection of the Environment
- 4.18 Electricity, Water & Gas
- 4.19 Procuring Entity's Equipment and Free-Issue Materials
- 4.20 Progress Reports
- 4.21 Security of the Site.
- 4.22 Contractor's Operations on Site.
- 4.23 Fossils/ Antiques and Articles of value
- 4.24 Completion Plans to be submitted by the Contractor.
- 4.25 Contractor to Supply Tools & Plants etc.
- 4.26 Changes in the firm's constitution to be intimated.

5. Nomination of Sub- Contractor

- 5.1 Sub Contractor
- 5.2 Definition of "nominated Subcontractor
- 5.3 Objection to Nomination
- 5.4 Payment to nominated Subcontractors
- 5.5 Evidence of Payments

6. Engagement of Staff and Labour by the Contractor

- 6.1 Staff and Labour
- 6.2 Bidder barred from bidding if near relatives working in Procuring Entity office
- 6.3 Employment of Technical Staff and employees
- 6.4 Responsibility of the Technical Staff & Employees
- 6.5 Rates of Wages and Conditions of Labour
- 6.6 Contractor not to engage staff of Procuring Entity
- 6.7 Working Hours
- 6.8 Facilities for Staff and Labour
- 6.9 Health & Safety
- 6.10 Contractor's Superintendence
- 6.11 Contractors Personnel
- 6.12 Records of Contractor's Personnel and Equipment
- 6.13 Disorderly Conduct
- 6.14 Foreign Personnel
- 6.15 Supply of Foodstuffs
- 6.16 Supply of Water
- 6.17 Measures against Insect and Pest Nuisance
- 6.18 Alcoholic Liquor or Drugs
- 6.19 Arms and Ammunition
- 6.20 No Unlicensed storage of Explosives and POL

- 6.21 Prohibition of Forced or Compulsory Labour
- 6.22 Prohibition of Child Labour
- 6.23 Festivals and religious customs
- 6.24 Employment Records of Workers
- 6.25 Compliance with Labour Laws
- 6.26 Payment of Wages
- 6.27 Penalty for noncompliance with labour Law

7.Execution of Works and Workmanship

- 7.1 Manner of Execution
- 7.2 Samples
- 7.3 Inspection
- 7.4 Store supply by the Procuring Entity
- 7.5 Penal Rate in case of Excess consumption
- 7.6 Hire of Plant & machinery
- 7.7 Imported store Article to be obtained from the Procuring Entity
- 7.8 Material supplied by the Contractor
- 7.9 Testing
- 7.10 Cost of Samples
- 7.11 Cost of Tests
- 7.12 Cost of Test not provided for
- 7.13 Rejection
- 7.14 Remedial Work
- 7.15 Ownership of Plant & Machinery
- 7.16 Dismantled Material Government Property
- 7.17 Action where no Specifications are specified
- 7.18 Royalties

8. Commencement, Delays & Suspensions.....

- 8.1 Fixing central lines reference points and bench Marks
- 8.2 Setting out of Works
- 8.3 Commencement of Works
- 8.4 Time for Completion
- 8.5 Construction Programme
- 8.6 Extension of Time for Completion
- 8.7 Delays Caused by Authorities
- 8.8 Rate of Progress of work.
- 8.9 Compensation for Delay(Liquidated Damage)
- 8.10 Suspension of work
- 8.11 Consequences of Suspension
- 8.12 Payment for Plant and Materials in Event of Suspension
- 8.13 Prolonged Suspension
- 8.14 Resumption of Work
- 8.15 Work to be executed strictly as per specification
- 8.16 Action in case work not done as per Specification

9.Deviations, Variations, Adjustments.....

- 9.1 Right to Vary
- 9.2 Deviations/Variations Extent and Pricing
- 9.3 Value Engineering
- 9.4 No compensation for alterations in or restriction of Works to be carried out
- 9.5 Monthly Return of Extra Claims
- 9.6 Provisional Sums
- 9.7 Day Work

10. Price Variation

- 10.1 Price Variation due to change in the price of Labour , Materials
- 10.2 Price Variation in Installation of elevator, supply/ Installation
- 10.3 General Conditions for admissibility of Price Variation

11. Tests on completion.....

- 11.1 Contractor's obligations
- 11.2 Delayed tests
- 11.3 Retesting
- 11.4 Failure to pass tests on Completion

12. Taking over works and sections

- 12.1 Taking over works.
- 12.2 Taking over parts of works.
- 12.3 Taken over if tests on completion suffer with interference.
- 12.4 Surface requiring reinstatement.

13. Defect Liability

- 13.1 Defect liability period.
- 13.2 Completion of Outstanding Work and Remedying Defects.
- 13.3 Cost of Remedying Defects.
- 13.4 Extension of Defects Notification Period.
- 13.5 Contractor liable fro Damage Defects during Maintenance Period
- 13.6 Failure to Remedy Defects.
- 13.7 Removal of Defective Work.
- 13.8 Further Tests.
- 13.9 Contractor / Third Party Quality Inspection Agency to Search for causes of defects.
- 13.10 Performance Certificate.
- 13.11 Substantial Completion of Parts.
- 13.12 Unfulfilled Obligations.
- 13.13 Right to Access.
- 13.14 Clearance of Site.

14. Measurement and Evaluation

- 14.1 Measurement of Work Done
- 14.2 Method of Measurement
- 14.3 Omission

- 15. Contract Price, Payments and Lien.....**
 - 15.1 Contract Price
 - 15.2 Lump sum Provisions in Estimate/content
 - 15.3 Schedule of Payments
 - 15.4 Application for Interim Payment certificate
 - 15.5 Issue of Interim Payment certificate
 - 15.6 Payment of an Interim Payment certificate
 - 15.7 Payment on Intermediate certificate to be regarded as advance
 - 15.8 Application for issue of Completion Certificate
 - 15.9 Issue of final Completion Plans
 - 15.10 Final settlement of Payment
 - 15.11 Discharge
 - 15.12 Payment of final bill
 - 15.13 Recovery of cost of preparation of Bill
 - 15.14 Payment of Contractors Bills to Bank
 - 15.15 Advance Payment
 - 15.16 Secured Advance on non-perishable materials
 - 15.17 Ensuring Payment and Amenities to workers if Contractor fails to pay
 - 15.18 Withholding and lieu in respect of sums due from Contractors
 - 15.19 Lien in respect of claims in other contract
 - 15.20 Levy or Taxes payable by Contractor
 - 15.21 Conditions for reimbursement of Levy/Taxes if levied after receipt of Tenders
 - 15.22 Pre-check & post check of Bills

- 16. Termination of Contract by Procuring Entity**
 - 16.1 Termination by Procuring Entity
 - 16.2 Contractor liable to pay compensation
 - 16.3 Valuation at the date of termination
 - 16.4 Payment after termination
 - 16.5 Procuring Entity's Entitlement to Termination for convenience
 - 16.6 Corrupt or fraudulent Practices
 - 16.7 Termination of Contract on death of Contractor

- 17. Suspension of works and Termination by the Contractor.....**
 - 17.1 Contractor's Entitlement to suspend work
 - 17.2 Termination by contractor
 - 17.3 Cession of work and removal of contractor's equipment
 - 17.4 Payment on termination

- 18. Risk & Responsibilities**
 - 18.1 Indemnities
 - 18.2 Contractor's care of the works
 - 18.3 Procuring Entity's Risks
 - 18.4 Consequences of procuring Entity's risks
 - 18.5 Intellectual and Industrial Property Rights
 - 18.6 Limitation of Liability
 - 18.7 Use of Procuring Entity's Accommodation/Facilities

- 19. Force Majeure**
 - 19.1 Definition of Force Majeure
 - 19.2 Notices of force Majeure
 - 19.3 Duty to Minimize Delay
 - 19.4 Consequences of Force Majeure
 - 19.5 Force Majeure Affective Subcontractor
 - 19.6 Optional Termination Payment and Release
 - 19.7 Release from Performance
- 20. Insurance**
 - 20.1 General Requirements for Insurance
 - 20.2 Insurance for works and contractor's Equipment
 - 20.3 Insurance against injury to Persons and Damage to Property
 - 20.4 Insurance for Contractors Personnel
- 21. Claims, Disputes and Arbitration**
 - 21.1 Recovery
 - 21.2 Contractor's Claims
 - 21.3 Dispute Resolution

- Appendix A : General Conditions of Admissibility of Escalation.....**

- Appendix B : Dispute Resolution during execution of the Contract.....**

1. General Provisions

Sub-Title	Sub-Clause	Provision
Definitions	1.1	In the Conditions of Contract (these General Conditions) which include Special Conditions, the following works and expressions shall have the meaning stated as under. Words indicating persons or parties include firms, companies, and other legal entities except where context requires otherwise.
The Contract	1.1.1	
	1.1.1.1	Bill of Quantities (BOQ) means the priced and completed Bill of Quantities forming part of the Bid. Activity Schedule means the various stages of execution of the Works in case of Lump Sum Contract which are linked to payment Schedule.
	1.1.1.2	Contract means the document forming the Bid and acceptance thereof and the formal agreement executed between the competent authority on behalf of the Governor of Rajasthan and the Contractor, together with the documents referred to there in including these conditions, the Specifications, designs, Drawings and instructions issued from time to time on Contract and shall be complementary to one another.
	1.1.1.3	Contract Agreement means the Contract Agreement referred to in Sub-Clause 1.81 [Signing of the Contract].
	1.1.1.4	Contract Data means the pages completed by the Procuring Entity entitled Contract Data which constitute the Special Conditions of the Contract.
	1.1.1.5	Drawings means the Drawings of the Works, as included in the Contract and any additional and modified drawings issued by (or on behalf of) the Procuring Entity in accordance with the Contract.
	1.1.1.6	Letter of Acceptance means the letter of formal acceptance, signed by the Procuring Entity, including any annexed memoranda comprising agreements between and signed by both Parties. If there is no such Letter of Acceptance, the expression "Letter of Acceptance" means the Contract Agreement and the date of issuing the Letter of Acceptance means the date of signing the Contract Agreement.
	1.1.1.7	Letter of Technical/Financial Bid means the document entitled Letter Technical or Letter of Financial bid, which was completed by the Bidder and includes the signed offer to the Procuring Entity for the Works.
	1.1.1.8	Risk and Cost means when the Contractor fails to complete the Contract despite due notices, the procuring entity may terminate the Contract with full 10% compensation and/ or measure the acceptable work done

		and get the balance work of the BOQ/ Activity Schedule carried out at the risk and cost of the Contractor and the difference of cost at which the balance work is carried out through the Department/ Organisation or another agency is debited to the Contractor.
	1.1.1.9	Schedules means the document(s) entitled Schedules, completed by the Contractor and submitted with the letter of Bid, as included in the Contract. Such documents may include the Bill of Quantities, data, lists and Schedules of rates and /or prices.
	1.1.1.10	Specifications means the BIS, IRC, and other Code Specification of the Works followed by relevant Department of the Government of India/State Government and/or included in the Contract and any modification or addition made or approved by the Engineer-in-Charge.
	1.1.1.11	Technical/ Financial Bid means the Letter of Technical or Financial Bid and all other documents which the Bidder submitted with the Letter of Technical or Financial Bid, as included in the Contract.
Parties and Persons	1.1.2	
	1.1.2.1	Party: means the Procuring Entity or the Contractor, or both as the context requires.
	1.1.2.2	Contractor shall mean the individual, firm or company, whether incorporate or not undertaking the Works and shall include the legal or authorised representative of such individual or the persons composing such firm or company or the successors of such firm or company and the permitted as signees of such individual, firm or company.
	1.1.2.3	Contractor's Personnel means the Contractor and Contractor's Representative and all personnel whom the Contractor utilizes on Site, who may include the staff, labour and other employees of the Contractor and of each Subcontractor; and any other personnel assisting the Contractor in the execution of the Works. All communications addressed to the Contractor can be handed over at site to the Contractor's personnel.
	1.1.2.4	Contractor's Representative means the person named by the Contractor in the Contract or appointed from time to time by the Contractor under Sub-Clause 4.5 [Contractor's Representative], who acts on behalf of the Contractor.
	1.1.2.5	Engineer-in-Charge or Engineer means the Divisional officer / Executive Engineer who shall be in-charge of the Works and who shall sign the Contract on behalf of the Governor of Rajasthan and who shall be responsible for supervising the Contract, administering the Contract, certifying payments due to the Contractor, issuing and valuing Variations to the Contract, awarding extension of time, valuing the Compensation events, etc.

	1.1.2.6	The Procuring Entity or PE means the Party who employs the Contractor to carry out the Works.
	1.1.2.7	Procuring Entity's Personnel means the Engineer-in-Charge, the assistants referred to in Sub-Clause 3.2 [Delegation by the Engineer-in-Charge] and all other staff, labour and other employees of the Engineer-in-Charge and of the Procuring Entity; and any other personnel notified to the Contractor, by the Procuring Entity or the Engineer-in-Charge, as Procuring Entity's Personnel.
	1.1.2.8	Subcontractor means any person / firm named in the Bid /Contract and approved by the Engineer-in-Charge as a Subcontractor, or any person appointed and approved as a Subcontractor subsequently, for a part of the Works; and the legal successors in title to each of these persons/ firms.
Dates, tests and periods of completion	1.1.3	
	1.1.3.1	Base Date means the date 28 Days prior to the last date specified for submission of the Bid.
	1.1.3.2	Commencement/ start Date means the date specified under Sub-Clause 8.3.1 [Commencement of Works].
	1.1.3.3	A Defect is any part of the Works not completed in accordance with the approved specifications, designs and/ or drawings of the Contract.
	1.1.3.4	The Defect Liability Certificate is the certificate issued by Engineer-in-Charge after Defect Liability Period has ended and upon correction of Defects <i>pointed out</i> by the Engineer-in-Charge.
	1.1.3.5	The Defect Liability Period will be decided by the Department/ Organisation depending on nature of the Works, from the date of completion of the Works and shall be mentioned in the Contract Data.
	1.1.3.6	Defects Notification Period means the period for notifying Defects in the Works or a Section (as the case may be) under Sub-Clause 13.2 [Completion of Outstanding Work and Remedying Defects], which extends over twelve Months except if otherwise stated in the Contract Data (with any extension under Sub-Clause 13.4 [Extension of Defects Notification Period], calculated from the date on which the Works or Section is completed as certified under Sub-Clause 12.1 [Taking Over of the Works and Sections].
	1.1.3.7	Performance Certificate means a certificate issued under Sub-Clause 13.10 [Performance Certificate].
	1.1.3.8	Taking-Over Certificate means a certificate issued under Sub-Clause 12.1 [Taking Over of the Works and Sections].

	1.1.3.9	Tests on Completion means the tests which are specified in the Contract or agreed by both Parties or instructed as a Variation, and which are carried out under Clause 11 [Tests on Completion] before the Works or a Section (as the case may be) are taken over by the Procuring Entity.
	1.1.3.10	Tests after Completion means the tests (if any) which are specified in the Contract and which are carried out in accordance with the Specification after the Works or a Section (as the case may be) is taken over by the Procuring Entity.
	1.1.3.11	The Intended Completion Date is the date on which it is intended that the Contractor shall complete the Works. The Intended Completion Date is specified in the Contract Data. The Intended Completion Date may be revised only by the Engineer-in Charge by issuing an extension of time.
	1.1.3.12	Time for Completion means the time for completing the Works or a section (as the case may be) under Sub-Clause 8.4 [Time for Completion], as stated in the Contract Data (with any extension under Sub-Clause 8.6 [Extension of Time for Completion], calculated from Commencement Date.
	1.1.3.13	Day means calendar Day; Year means a period of 365 Days.
Money and Payments	1.1.4	
	1.1.4.1	Accepted Contract Amount means the amount accepted in the Letter of Acceptance for execution and completion of the Works and remedying of any defects and maintaining the Works, if stated in the Contract.
	1.1.4.2	Cost means all expenditure reasonably incurred (or to be incurred) by the Contractor, whether on or off the Site, including over head and similar charges, but does not include profit.
	1.1.4.3	Final Payment Certificate means the Payment Certificate issued under Sub-Clause 15.9 [Issue of Final Completion Certificate].
	1.1.4.4	Final Statement means the statement defined in Sub-Clause 15.10 [Final Statement of Payments].
	1.1.4.5	Interim Payment Certificate means a Payment Certificate issued under Sub-Clause 15.5 [Issue of Interim Payment Certificate], other than the Final Payment Certificate.
	1.1.4.6	Market Rate of an item shall be the current rate as decided by the Engineer-in Charge on the basis of the Cost of Materials and Labour at the Site where the work is to be executed for a variation item.
	1.1.4.7	Payment Certificate means a Payment Certificate issued under Clause 15 [Contract Price, Payment and Lien].
	1.1.4.8	Provisional sums/ Lump sums means a sum (if any)

		which is specified in the Contract as a provisional sum, for the execution of any part of the Works or for supply of Plant, Materials or services under Sub-Clause 9.6 [Provisional Sums]. These are also moneys provided in the estimate of the project to pay for unforeseen / unquantified items. It may also include lump sum provided in the estimate/ BOQ for unforeseen items to be paid after approval of analysis of rates of such items and charges payable to Government agencies or the contractor for approvals, service connections, extensions of services from the supply lines etc., as the case may be.
	1.1.4.9	Performance Security means an amount as percentage of the Accepted Contract Price deposited in the form of Bank Guaranteed or any other prescribed form deposited by the Contractor as a security for due performance of the Contract.
Works and Materials	1.1.5	
	1.1.5.1	Materials are all supplies, including consumables, used by the Contractor for consumption in the Works.
	1.1.5.2	Permanent Works means the Permanent Works to be executed by the Contractor under the Contract. These works shall have a defined designed life and durability.
	1.1.5.3	Plant means the apparatus, machinery and other equipment intended to form or forming part of the Permanent Works,
	1.1.5.4	Scope of work shall cover execution of all aspects of the Works as per the Contract.
	1.1.5.5	Section means apart of the Works specified in the Contract Data as a Section (if any).
	1.1.5.6	Specifications means the Specification (<i>BIS, IRC etc. or specifications approved by the department or others</i>)of the Works included in the Contract and any modification or addition made or approved by the Engineer-in Charge.
	1.1.5.7	Temporary Works are Works designed, constructed, installed, and removed by the Contractor which are needed for construction or installation of the Works.
	1.1.5.8	Work or Works shall, unless there is something either in the subject or context repugnant to such construction, be construed and taken to mean the Works by virtue of the Contract contracted to be executed whether temporary or permanent and whether original, altered, substituted or additional works.
Others	1.1.6	
	1.1.6.1	Act means the Rajasthan Transparency in Public Procurement Act, 2012.
	1.1.6.2	Contractor's documents are the bids (technical and financial) submitted, softwares, bills, reports, drawings, designs, letters/ communications, test results, etc., submitted by the Contractor to the Procurement Entity in

		connection with the Contract.
	1.1.6.3	Department means any Department of Government of Rajasthan which invite Bids on behalf of Governor of Rajasthan as specified in Contract Data.
	1.1.6.4	Field laboratory means the Contractor's equipped laboratory provided with equipments, experienced personnel, consumables, books of specifications and codes for use on quality testing/inspections on the works.
	1.1.6.5	Force Majeure is defined in Sub-Clause 19.1 [Definition of Force Majeure].
	1.1.6.6	Government/ Governor of Rajasthan means the State Government of Rajasthan/ Governor of Rajasthan
	1.1.6.7	Laws means all the national or the state legislations, statutes, ordinances and other laws, and regulations and by-laws of India and Rajasthan and any legally constituted public authority.
	1.1.6.8	Procuring Entity's Equipments means the apparatus, machinery and vehicles (if any) made available by the Procuring Entity on hire for the use of the Contractor in the execution of the Works, as stated in the Specifications; but does not include Plant which has not been taken over by the Procuring Entity.
	1.1.6.9	Rules means the Rajasthan Transparency in Public Procurement Rules, 2013
	1.1.6.10	Site shall mean land and/or other places on, into or through which work is to be executed under the Contract or any adjacent land, path or street through which work is to be executed under the Contract or any adjacent land, path or street which may be allotted or used for the purpose of carrying out the Contract.
	1.1.6.11	Site office means a suitable covered all weather usable space built by the Contractor at Site of Works at his cost for use by him and the Procuring Entity.
	1.1.6.12	Unforeseeable means not reasonably foreseeable by an experienced Contractor by the Base Date.
	1.1.6.13	Variations mean any change to the Works, which is instructed or approved as a variation under Clause 9 [Deviations, Variations and Adjustments].
Interpretation	1.2	In the Contract, except where the context requires otherwise (a) words indicating one gender include all genders; (b) words indicating the singular also include the plural and (c) words indicating the plural also include the singular; (d) provisions including the word "agree", "agreed" or "agreement" require the agreement to be recorded in writing; (e) "written" or "in writing" means hand-written, type-written, printed or electronically made, and resulting in a permanent record; (f) the word "tender" is synonymous with "bid" and "tenderer" with "bidder" and the words "tender

		document” with “bidding document”. The marginal words and other headings shall not be taken into consideration in the interpretation of these Conditions.
Communications	1.3	<p>Wherever these Conditions provide for the giving or issuing of approvals, certificates, consents, determinations, notices, requests and discharges, by one party to the other, these communications shall be:</p> <ol style="list-style-type: none"> i. in writing and delivered by hand against receipt, sent by mail or courier, or transmitted using any of the agreed systems of electronic transmission as stated in the Contract Data; and ii. delivered, sent or transmitted to the address for the recipient’s Communications as stated in the Contract Data. However: <ol style="list-style-type: none"> a) if the recipient gives notice of an other address, communications shall there after be delivered accordingly; and b) if the recipient has not stated otherwise when’re requesting an approval or consent, it may be sent to the address from which the request was issued. <p>Approvals, certificates, consents and determinations shall not be unreasonably withheld or delayed. When a certificate is issued to a Party, the certifier shall send a copy to the other Party. When a notice is issued to a Party, by the other Party or the Engineer-in-Charge, a copy shall be sent to the Engineer-in-Charge or the other Party, as the case may be.</p>
Law and language	1.4	<p>The Contract shall be governed by the laws of India and the State of Rajasthan.</p> <p>The ruling language of the Contract shall be English or that stated in the Special Conditions of Contract.</p>
Works to be carried out	1.5	<p>The Works to be carried out under the Contract shall, except as otherwise provided in these conditions, include all labour, materials, equipment, tools, plants, testing and quality assurance, and transport which may be required in preparation of and doing in the full and entire execution and completion of the Works. The descriptions given in the Schedule of Quantities (Activity Schedule in case of Lump Sum Contract) shall unless otherwise stated, be held to include wastage on Materials, carriage and cartage, carrying and return of empties, hoisting, setting, fitting and fixing in position and all other Labour necessary in and for the full and entire execution and completion of the Works as aforesaid in accordance with good practice and recognized principles to deliver a work of specified quality and durability conforming to designs, drawings etc.</p> <p>The Works include clearance, levelling and dressing of Site within a distance of 15 meters of the work site on all</p>

		sides except where the building adjoins another building.
Sufficiency of Tender/ Bid	1.6	The Contractor shall be deemed to have satisfied himself before bidding as to the correctness and sufficiency of his Bid for the Works and of the rates and prices quoted in the Schedule of Quantities, which rates and prices shall, except as otherwise provided, cover all his obligations under the Contract and all matters and things necessary for the proper completion and maintenance of the Works. He shall also be responsible for satisfying himself on the completeness of the documents /data provided by the Procuring Entity. He shall not raise any objections or deficiencies or inaccuracies in such documents.
Discrepancies and adjustment of errors	1.7.1	The several documents forming the Contract are to be taken as mutually explanatory of one another, detailed Drawings being followed in preference to small scale Drawing and figured dimensions in preference to scale and special conditions in preference to General Conditions.
	1.7.2	In the case of discrepancy between the Bill of Quantities, the Specifications and/or the Drawings, the following order of preference shall be observed: <ul style="list-style-type: none"> • Description of Bill of Quantities • Particular <i>detailed</i> Specification and Special Condition, if any • Drawings / Designs • IRC / MORT&H , ASTHO Specification, if required • Indian Standard Specifications or B.I.S.
	1.7.3	If there are varying or conflicting provisions made in any one document forming part of the Contract, the Procuring Entity shall be the deciding authority with regard to the intention of the document and his decision shall be final and binding on the Contractor.
	1.7.4	Any error in description, quantity or rate in Bill of Quantities or any omission therefore shall not vitiate the Contractor release the Contract or from the execution of the whole or part of the Works comprised there in according to Drawings and Specifications or from any of his obligations under the Contract.
Signing of the Contract	1.8.1	The successful Bidder, after submitting the performance guarantee i.e. within 15 Days of receipt of Notification of Award or as specified in the Contract Data, shall attend the office of the Procurement Entity / Engineer-in-charge for authentication, signing and completion of the Contract document and execute the agreement consisting of: The notice inviting Bid, all the documents including Drawings, if any, forming the Bidding Document as issued at the time of invitation of bids and acceptance thereof together with any correspondence leading there to, Standard Forms consisting of various standard Sub-Clauses with corrections up to the date stipulated in

		<p>Contract Data along with annexure thereto and drawings etc.</p> <p>The Costs of stamp duties and similar charges (if any) imposed by Law in connection with entry in to the Contract Agreement shall be borne by the Contractor.</p>
Signed copy of Contract Document to be given to Contractor	1.8.2	<p>The Contractor shall be furnished, free of Cost one signed copy of the Contract Documents together with all Drawings except standard Specifications (BIS or IRC or others), Schedule of Rates and such other printed and published documents, which shall be procured by the Contractor at his cost. <i>These documents shall be deemed to be part of the Contract. These shall be kept in the Site office.</i> None of these documents shall be used for any purpose other than that of this Contract.</p>
Conditions of the Contract	1.8.3	<p>The Contract shall be governed by the General Conditions of Contract (GCC). The Special Conditions of Contract (SCC)/ Contract Data, wherever applicable, shall supersede/ clarify the GCC to the extent specified.</p>
Priority of Documents	1.8.4	<p>The documents forming the Contract are to be taken as mutually explanatory of one another. For the purposes of interpretation, the priority of the documents shall be in accordance with the following sequence:</p> <ol style="list-style-type: none"> (a) the Contract Agreement, (b) the Letter of Acceptance, (c) the Technical Bid and Financial Bid along with the letters of the Technical Bid and Financial Bid (d) the Contract Data/ Special Conditions of Contract, (e) the General Conditions of Contract, (f) the Scope of Work & Specifications, (g) the Drawings, (h) the Instructions to Bidders, (i) the Notice Inviting Bids, and (j) the Schedules and any other documents forming part of the Contract. <p>If an ambiguity or discrepancy is found in the documents, the Engineer-in-Charge shall issue any necessary clarification or instruction.</p>
Personnel	1.9.1	<p>The Contractor shall employ the key personnel named in the Schedule of Key Personnel as referred to in the qualification criteria to carry out the functions stated in the Schedule or other personnel approved by the Engineer-in-Charge. The Engineer-in-Charge will approve any proposed replacement of key personnel only if their qualifications, abilities, and relevant experiences are substantially equal to or better than those of the personnel listed in the Schedule.</p>
	1.9.2	<p>If the Engineer-in-Charge asks the Contractor to remove a person who is a member of the Contractor's staff or his work force stating reasons, the Contractor shall ensure that the person leaves the Site within seven Days and has</p>

		no further connection with the work in the Contract.
Procuring Entity's Risks	1.10	<p>The Procuring Entity is responsible for the excepted risks which are :</p> <p>(a) In so far as they directly affect the execution of the Works in India, the risks of war, hostilities, invasion, act of foreign enemies, rebellion, revolution, insurrection or military or usurped power, civil war, riot commotion or disorder (unless restricted to the Contractor's employees), and contamination from any nuclear fuel or nuclear waste or radioactive toxic explosive, or</p> <p>(b) A cause due solely to the design of the Works, other than the Contractor's design.</p>
Contractor's Risks	1.11	All risks of loss of or damage to physical property and of personal injury and death which arise during and in consequence of the performance of the Contract other than the Procuring Entity's risks are the responsibility of the Contractor.
Procuring Entity's use of Contractor's documents	1.12	<p>As between the Parties, the Contractor shall retain the copy right and other intellectual property rights in the Contractor's Documents and other design documents made by (or on behalf of)the Contractor. The Contractor shall be deemed (by signing the Contract) to give to the Procuring Entity a non-terminable transferable non-exclusive royalty-free license to copy, use and communicate the Contractor's Documents, including making and using modifications of them. This license shall:</p> <p>i. Apply throughout the actual or intended working life (whichever is longer) of the relevant parts of the Works,</p> <p>ii. Entitle any person in proper possession of the relevant part of the Works to copy, use and communicate the Contractor's Documents for the purposes of completing, operating, maintaining, altering, adjusting, repairing and demolishing the Works, and in the case of Contractor's Documents which are in the form of computer programs and other software, permit their use on any computer on the Site and other places as envisaged by the Contract, including replacements of any computers supplied by the Contractor.</p> <p>iii. The Contractor's Documents and other design documents made by (or on behalf of) the Contractor shall not, without the Contractor's consent, be used, copied or communicated to a third Party by (or on behalf of) the Procuring Entity for purposes other than those permitted under this Sub-Clause.</p>
Contractor's use of	1.13	As between the Parties, the Procuring Entity shall retain the copyright and other intellectual property rights in the

<p>Procuring Entity's Documents</p>		<p>Specification, the Drawings and other documents made by (or on behalf of) the Procuring Entity. The Contractor may, at his Cost, copy, use, and obtain communication of these documents for the purposes of the Contract. They shall not, without the Procuring Entity's consent, be copied, used or communicated to a third Party by the Contractor, except as necessary for the purposes of the Contract.</p>
<p>Care and Supply of documents</p>	<p>1.14</p>	<p>The approved Specification, Designs and Drawings shall be in the custody and care of the Procuring Entity. Unless otherwise stated in the Contract, one copy of the Contract and of each subsequent Drawing shall be supplied to the Contractor, who may make further copies at his Cost.</p> <p>Each of the Contractor's Documents shall be in the custody and care of the Contractor, unless and until taken over by the Procuring Entity. Unless otherwise stated in the Contract, the Contractor shall supply to the Engineer-in-Charge four copies of each of the Contractor's Documents.</p> <p>The Contractor shall keep, on the Site, a copy of the Contract, publications named in the Specification, the Contractor's Documents (if any), the Drawings and Variations and other communications given under the Contract. The Procuring Entity's Personnel shall have the right of access to all these documents at all reasonable times.</p> <p>If a Party becomes aware of an error or Defect in a document which was prepared for use in executing the Works, the Party shall promptly give notice to the other Party of such error or Defect.</p>
<p>Delays in issuing drawings or instructions.</p>	<p>1.15</p>	<p>The Contractor shall give notice to the Engineer-in-Charge whenever the Works are likely to be delayed or disrupted if any necessary Drawing or instruction is not issued to the Contractor with in a particular time, which shall be reasonable. The notice shall include details of the necessary Drawing or instruction, details of why and by when it should have been issued, and the nature and amount of the delay or disruption likely to be suffered if it is late.</p> <p>If the Contractor suffers delay and/or incurs Cost as a result of a failure of the Engineer-in-Charge to issue the notified Drawing or instruction within a time which is reasonable and is specified in the notice with supporting details, the Contractor shall give a further notice to the Engineer-in-Charge and shall be entitled subject to Sub-Clause 21.2 [Contractor's Claims] to an extension of time for any such delay, if completion is or will be delayed, under Sub-Clause 8.6 [Extension of Time for Completion],</p>

		However, if and to the extent that the Engineer-in-Charge's failure was caused by any error or delay by the Contractor, including an error in, r delay in the submission of, any of the Contractor's Documents, the Contractor shall not be entitled to such extension of time,
Confidential Details	1.16	<p>The Contractor's and the Procuring Entity's Personnel shall not disclose all such confidential and other information as may be reasonably required in order to verify compliance with the Contract and allow its proper implementation.</p> <p>Each of them shall treat the details of the Contract as private and confidential, except to the extent necessary to carry out their respective obligations under the Contract or to comply with applicable Laws. Each of them shall not publish or disclose any particulars of the Works prepared by the other Party without the previous agreement of the other Party. However, the Contractor shall be permitted to disclose any publicly available information, or information otherwise required to establish his qualifications to compete for other projects.</p>
2. The Procuring Entity		
Right of Access to the Site	2.1	<p>The Procuring Entity shall give the Contractor right of access to, and possession of at least 80% of the Site within 30 days of signing of the Contract or within the time specified in the Special Conditions of Contract (SCC). If under the Contract the Procuring Entity is required to give to the Contractor possession of any foundation, structure, plant or means of access, the Procuring Entity shall do so in the time and manner stated in the Specification. However, the Procuring Entity may withhold any such right or possession until the Performance Security has been received.</p> <p>If the Contractor suffers delay as a result of a failure by the Procuring Entity to give any such right or possession within such time, the Contractor shall give notice to the Engineer-in-charge and shall be entitled subject to Sub-Clause 21.2 [Contractor's Claims] to an extension of time for any such delay, if completion is or will be delayed,</p> <p>After receiving this notice, the Engineer-in-charge shall proceed to agree or determine these matters</p> <p>However, if and to the extent that the Procuring Entity's failure was caused by any error or delay by the Contractor, including an error in, or delay in the submission of, any of the Contractor's Documents, the Contractor shall not be entitled to such extension of time.</p>
	2.2	The right and possession may not be exclusive to the Contractor.
Assistance by	2.3	The Procuring Entity shall provide, at the request of the

Procuring Entity		Contractor, such reasonable assistance as to allow the Contractor to obtain expeditiously any permits, licenses or approvals which the Contractor is required to obtain : i. For the delivery of Goods, including clearance through customs, and ii. For the export of Contractor's Equipment when it is removed from the Site.
Procuring Entity's Personnel	2.4	The Procuring Entity shall be responsible for ensuring that the Procuring Entity's Personnel and the Procuring Entity's other Contractors on the Site, co-operate with the Contractor's efforts under Sub-Clause 4.7[Co-operation],and take actions similar to those which the Contractor is required to take under Sub-Clause 4.8[Safety Procedures]and under Sub-Clause 4.17 [Protection of the Environment]
Procuring Entity's Claims	2.5	If the Procuring Entity considers himself to be entitled to any payment under any Sub-Clause of these Conditions or otherwise in connection with the Contract, and/or to any extension of the Defects Liability Period, the Procuring Entity or the Engineer-in-charge shall give notice and particulars to the Contractor. However, notice is not required for payments due under Sub-Clause 4.18 [Electricity, Water and Gas], under Sub-Clause 4.19 [Issue of Procuring Entity's Equipment and Materials], or for other services requested by the Contractor. The notice shall be given as soon as practicable and no longer than 28 Days after the Procuring Entity became aware, or should have become aware, of the event or circumstances giving rise to the claim. A notice relating to any extension of the Defects Notification Period shall be given 28 days before the expiry of such period. The particulars shall specify the Sub-Clause or other basis of the claim, and shall include substantiation of the amount and/or extension Defects Notification Period to which the Procuring Entity considers himself to be entitled in connection with the Contract. The Engineer-in-charge shall then proceed in accordance with Sub-Clause 3.5 [Determinations] to agree or determine the amount (if any) which the Procuring Entity is entitled to be paid by the Contractor, and/or the extension (if any) of the Defects Notification Period in accordance with Sub-Clause 13.4 [Extension of Defects Notification Period]. This amount may be included as a deduction in the Contract Price and Payment Certificates. The Procuring Entity shall be entitled to set off against or make any deduction from an amount certified in a Payment Certificate, or to otherwise claim against the Contractor, in accordance with this Sub-Clause.
Quality Control	2.6	The Procuring Entity shall have the right to exercise proper Quality Control measures. The Contractor shall provide a

		<p>fully equipped field laboratory, testing personnel, consumables and other assistance at his cost to conduct such tests. The Quality Control shall be in three tiers :</p> <p>i) tier one by the Contractor's Engineers to the specified frequency,</p> <p>ii) by the Engineer-in-Charge's personnel to conform the quality and acceptance of the work and</p> <p>iii) by the Technical Examiner's organisation or such other independent bodies of State Government/ the Department/ Organisation or QCI approved Third Party Quality Inspection Agency. The work shall have to be completed to conform to the specifications and shall be acceptable only after rectification of deficient /defective works as per 'Non Conformance Reports', if any, issued by the above mentioned agency or the Engineer-in-Charge.</p>
3. Engineer-in-Charge		
Duties and Responsibilities	3.1.1	<p>The Executive Engineer of the concerned Division will function as the Engineer-in-Charge for the purpose of the Contract or the Procuring Entity shall appoint another engineer as the Engineer-in-charge, as specified in the Contract Data, who shall carry out the duties assigned to him in the Contract and ensure execution of works as per approved drawings, designs, specifications etc.. The Engineer-in-charge's staff shall include suitably qualified Engineers and other professionals who are competent to carry out these duties.</p> <p>The Engineer-in-charge shall have no authority to amend the Contract. The Engineer-in-charge may exercise the authority attributable to the Engineer-in-charge as specified in or necessarily to be implied from the Contract. If the Engineer-in-charge is required to obtain the approval of the Procuring Entity before exercising a specified authority, he shall have to obtain that approval.</p>
	3.1.2	<p>The Procuring Entity shall promptly inform the Contractor of any change to the authority attributed to the Engineer-in-charge.</p> <p>However, whenever the Engineer-in-charge exercises a specified authority for which the Procuring Entity's approval is required, then (for the purposes of the Contract) the Procuring Entity shall be deemed to have given approval.</p> <p>Except as otherwise stated in these Conditions:</p> <p>i. whenever carrying out duties or exercising authority, specified in or implied by the Contract, the Engineer-in-charge shall be deemed to act for the Procuring Entity;</p> <p>ii. the Engineer-in-charge has no authority to relieve either Party of any duties, obligations or responsibilities under the Contract; and</p> <p>iii. any approval, check, certificate, consent,</p>

		<p>examination, inspection, instruction, notice, proposal, request, test, or similar act by the Engineer-in-charge (including absence of disapproval) shall not relieve the Contractor from any responsibility he has under the Contract, including responsibility for errors, omissions, discrepancies, quality of works and non-compliances to specifications/ instructions of the Engineer-in-charge /Procuring Entity.</p> <p>iv. Any act by the Engineer-in-charge in response to a Contractor's request except otherwise expressly specified shall be notified in writing to the Contractor within 28 Days of receipt.</p> <p>The Engineer-in-charge shall obtain the specific approval of the competent authority before taking action under the following Sub-Clauses of these Conditions and other Sub-Clauses, if specified in the Contract Data:</p> <p>i. Sub-Clause 4.12 [Unforeseeable Physical Conditions] agreeing or determining an extension of time and/or additional Cost.</p> <p>ii. Sub-Clause 9.1 [Right to Vary]: Instructing a Variation, except;</p> <p>(a) In an emergency situation as determined by the Engineer-in-charge, or</p> <p>(b) If such a Variation would increase the Accepted Contract Amount by less than the percentage specified in the Contract Data.</p> <p>iii. Approving a proposal for Variation submitted by the Contractor or in accordance with Sub-Clause 9.1 [Right to Vary] or Sub-Clause 9.3 [Value Engineering].</p> <p>Notwithstanding the obligation, asset out above, to obtain approval, if, in the opinion of the Engineer-in-charge, an emergency occurs affecting the safety of life or of the Works /workmen or of adjoining property, he may, without relieving the Contractor of any of his duties and responsibility under the Contract, instruct the Contractor to execute all such work or to do all such things as may, in the opinion of the Engineer-in-charge, be necessary to abate or reduce the risk. The Contractor shall forth with comply, despite the absence of approval of the competent authority, with any such instruction of the Engineer-in-charge. The Engineer-in-charge shall determine (<i>after due approval from the competent authority</i>) an addition to the Contract Price, in respect of such instruction, in accordance with Clause 9 [Deviations, Variations and Adjustments] and shall notify the Contractor accordingly, with a copy to the Procuring Entity.</p>
--	--	---

Delegation by Engineer- in-Charge	3.2	<p>The Engineer-in-charge may from time to time assign duties and delegate authority to assistants and may also revoke such assign mentor delegation. These assistants may include a resident Engineer, and/or independent inspectors appointed to inspect and/or test items of works and/or Materials. The assignment, delegation or revocation shall be in writing and shall not take effect until copies have been received by both Parties.</p> <p>However, unless otherwise agreed by both Parties, the Engineer-in-charge shall not delegate the authority to determine any matter in accordance with Sub-Clause 3.5 [Determinations]</p> <p>Each assistant, to whom duties have been assigned or authority has been delegated, shall only be authorized to issue instructions to the Contractor to the extent defined by the delegation. Any approval, check, certificate, consent, examination, inspection, instruction, notice, proposal, request, test, or similar act by an assistant, in accordance with the delegation, shall have the same effect as though the act had been an act of the Engineer-in-charge. However:</p> <ol style="list-style-type: none"> i. any failure to disapprove any work, Plant or Materials shall not constitute approval, and shall therefore not prejudice the right of the Engineer-in-charge to reject the work, Plant or Materials; ii. if the Contractor questions any determination or instruction of an assistant, the Contractor may refer the matter to the Engineer-in-charge, who shall promptly confirm, reverse or vary the determination or instruction.
Instruction of the Engineer-in-Charge	3.3	<p>The Engineer-in-charge may issue to the Contractor(at any time) instructions and additional or modified Drawings which may be necessary for the execution of the Works and the remedying of any Defects, all in accordance with the Contract. The Contractor shall only take instructions from the Engineer-in-charge, or from an assistant to whom the appropriate authority has been delegated under Sub-Clause 3.2. If an instruction constitutes a Variation, Clause 9[Deviations, Variations and Adjustments]shall apply.</p> <p>The Contractor shall comply with the instructions given by the Engineer-in-charge or delegated assistant, on any matter related to the Contract. Whenever practicable, their instructions shall be given in writing. If the Engineer-in-charge or a delegated assistant:</p> <ol style="list-style-type: none"> i. gives an oral instruction, ii. receives a written confirmation of the instruction, from (or on behalf of)the Contractor, within two working Days after giving the instruction, and iii. does not reply by issuing a written rejection and/or instruction within two working Days after receiving the confirmation, then the confirmation shall constitute the written instruction of the Engineer-in-

		charge or delegated assistant(as the case may be).
Replacement of Engineer-in-Charge	3.4	If the Procuring Entity intends to replace the Engineer-in-charge ,the Procuring Entity shall inform the contractor by a notice before the intended date of replacement, the name and contact details of the intended replacement of the Engineer-in-charge.
Determinations	3.5	Whenever these Conditions provide that the Engineer-in-charge shall proceed in accordance with this Sub-Clause 3.5 to agree or determine any matter like variations, extensions of time, responsibilities / valuation for loss and or damage to works etc., the Engineer-in-charge shall peruse the Contract, Specifications, Codes and consult the Contractor in an endeavour to reach an agreement. If an agreement is not reached, the Engineer-in-charge shall make a fair determination in accordance with the Contract, taking due regard of all relevant circumstances. The Engineer-in-charge shall give notice to the Contractor of each agreement or determination, with supporting particulars, within 28 Days from the likely date of implementation of such agreement or determination and obtain receipt of the corresponding claim or request except when otherwise specified. The Contractor shall give effect to each determination unless and until revised under Clause 21[Claims, Disputes and Arbitration].
Minutes of Meeting	3.6	The Engineer-in-charge may require the Contractor to attend a progress review / or quality assurance/ design review meeting during execution of the Works. The Engineer- in-charge shall record the minutes of the meeting and provide a copy within 7 days to the Contractor for compliance. These minutes will be a part of evidence in case of request for extension of time or variation or punitive action against the Contractor as per terms of the Contract. In case the issue of minutes is delayed, the Contractor

		may issue the record note of discussions and decisions taken in the meeting for record and confirmation by the Engineer-in Charge. These shall be treated as confirmed if not denied within 15 days by the Engineer-in-Charge.
4. The Contractor		
General Obligations and Contractor's personnel.	4.1.1	The Contractor shall design, prepare drawings(to the extent specified in the Contract),execute as per specifications and complete the Works in accordance with the Contract and with the Engineer-in-Charge's instructions, and shall remedy any Defects in the Works. The Contractor shall provide the Plant and Contractor's Documents specified in the Contract, and all Contractor's Personnel, Goods, consumables and other things and services, whether of a temporary or permanent nature, required in and for this design, execution, completion and remedying of Defects.
	4.1.2	The Contractor shall be responsible for the adequacy, stability and safety of all Site operations and of all methods of construction. Except to the extent specified in the Contract, the Contractor shall be responsible for all Contractor's Documents, Temporary Works, and such design of each item of works, Plant and Materials as is required for the item to be in accordance with the specifications for items of Contract, and shall not otherwise be responsible for the design or Specification of the Permanent Works.
	4.1.3	The Contractor shall deploy experienced and competent personnel to execute the works. The quality of workmanship has to be as specified. Personnel not found capable of good workmanship shall be removed and replaced with better workman.
	4.1.4	The Contractor shall, whenever required by the Engineer-in-charge, submit details of the arrangements and methods which the Contract or proposes to adopt for the execution of the Works. He shall also be responsible for the safety of works and personnel at the site and shall submit a safety execution plan (as per relevant code for safety at construction site) for the approval by the Engineer-in-charge. No significant alteration to these arrangements and methods shall be made without this having previously been approved by the Engineer-in-charge. He shall also comply to the requirements of the mitigations of the Environmental impacts of the execution of works.
	4.1.5	If the Contract specifies that the Contract or shall design any part of the Permanent Works, then unless otherwise stated in the Special Conditions of Contract: i. the Contractor shall submit to the Engineer-in-charge the Contractor's Documents for this part in accordance with the procedures specified in the

		<p>Contract.</p> <p>ii. these Contractor's Documents shall be in accordance with the Specification and Drawings, shall be written in the language for communications defined in the Sub-Clause 1.4 [Law and Language] and shall include additional information required by the Engineer-in-charge to add to the Drawings for co-ordination of each Party's designs;</p> <p>iii. the Contractor shall be responsible for this part and it shall, when the Works are completed, be fit for such purposes for which the part is intended as are specified in the Contract; and</p> <p>iv. prior to the commencement of the Tests on Completion, the Contractor shall submit to the Engineer-in-charge the "as-built" drawings, designs and documents and, if applicable, operation and maintenance manuals in accordance with the Specification and insufficient detail for the Procuring Entity to operate, maintain, dismantle, reassemble, adjust and repair all parts of the Works. Such part shall not be considered to be completed for the purposes of taking-over under Clause 12 [Taking Over of the Works and Sections] until these documents and manuals have been submitted to the Engineer-in-charge.</p>
	4.1.6	The Contractor shall allow the Engineer-in-charge and any person authorized by the Engineer-in-charge access to the Site, to any place where work in connection with the Contract is being carried out or is intended to be carried out and to any place where Materials or plant are being installed / assembled for the Works. The contractor may satisfy himself regarding site, acquisition of land, approach roads etc.
	4.1.7	The liability, if any, on account of quarry fees, royalties, octroi, service tax, and any other taxes and duties in respect of materials actually consumed on public work shall be borne by the Contractor.
	4.1.8	The cost of all water / power connections necessary for the execution of the Works and the cost of water consumed and hire charges of meters and the cost of electricity consumed in connection with the execution of the Works shall be paid by the Contractor except where otherwise specifically indicated. He shall also be responsible for environment mitigated disposal of waste water released during execution.
Compliance with the Code of Integrity	4.2.1	The Contractor is bound by the provisions of the Code of Integrity stipulated in the Act , the Rules and specified in ITB Sub-Clause 1.3 [Code of Integrity] and refrain himself from corrupt, fraudulent, coercive and collusive practices which are defined as below:

		<p>a) “corrupt practice” means the offering, giving, receiving, or soliciting, directly or indirectly, anything of value to influence improperly the actions of another party;</p> <p>b) “fraudulent practice” means any act or omission, including a misrepresentation, that knowingly or recklessly misleads, or attempts to mislead, a party to obtain a financial or other benefit or to avoid an obligation;</p> <p>c) “coercive practice” means impairing or harming, or threatening to impair or harm, directly or indirectly, any party or the property of the party to influence improperly the action sofa party;</p> <p>d) “collusive practice” means an arrangement between two or more parties designed to achieve an improper purpose, including influencing improperly the actions of another party.</p>
	4.2.2	The Procuring Entity shall take legal action against the Contractor, if it breaches any provisions of the Code of Integrity, under Section 11(3), 46 and chapter IV of the Act.
	4.2.3	The Contractor shall permit the Procuring Entity to inspect the Contractor’s accounts and records relating to the performance of the Contract and to have them audited by auditors appointed by the Procuring Entity, if so required by the Procuring Entity.
Performance Security	4.3.1	<p>The Contractor shall have the option to furnish a Performance Security @ 10% of the Contract value, in Indian Rupees, in one of the following forms [<i>strike out which is not applicable</i>]:</p> <ol style="list-style-type: none"> i. Deposit through eGRAS; or ii. Bank Draft or Banker's Cheque of a Scheduled Bank in India; or iii. National Savings Certificates and any other script/ instrument under National Savings Schemes for promotion of small savings issued by a Post Office in Rajasthan, if the same can be pledged under the relevant rules. They shall be accepted at their surrender value at the time of Bid and formally transferred in the name of the Procuring Entity with the approval of Head Post Master; or iv. Bank guarantee. It shall be of a scheduled Bank in India in prescribed or other acceptable format or from other Issuer acceptable to the Procuring Entity. The bank guarantee shall be got verified from the issuing bank and confirmer, if any; or v. Fixed Deposit Receipt (FDR) of a Scheduled Bank in India. It shall be in the name of the Procuring Entity on account of Bidder and discharged by the Bidder in advance. The Procuring Entity shall ensure before accepting the Fixed Deposit Receipt that the Bidder furnishes an undertaking from the bank to make

		<p>payment/ premature payment of the Fixed Deposit Receipt on demand to the Procuring Entity without requirement of consent of the Bidder concerned. In the event of forfeiture of the Performance Security, the Fixed Deposit shall be forfeited along with interest earned on such Fixed Deposit.</p> <p>vi. The Contractor shall have option to get the Performance Security deposited by deduction from his each running and final bill (Payment Certificate) @ 10% of the amount of the bill.</p>
Additional Performance Security	4.3.2	<p>i. If the Bid, which results in the lowest evaluated bid price, is seriously imbalanced or front loaded in the opinion of the Procuring Entity, the Procuring Entity may require the Bidder to produce detailed price analysis for any or all items of the Bill of Quantities to demonstrate the internal consistency of those prices with the construction methods and schedule proposed. After evaluation of the price analysis, taking into consideration the schedule of estimated Contract payments, the Procuring Entity may require that the amount of the performance security be increased (to a maximum of 20% of the bid value of such items) at the expense of the Bidder to a level sufficient to protect the Procuring Entity against financial loss in the event of default by the successful Bidder under the Contract.</p> <p>ii. Without limitation to the provisions of the rest of this Sub-Clause, whenever the Engineer-in-charge determines an addition to the Contract Price as a result of a change in Cost, or as a result of a Variation of the Contract Price, the Contractor shall at the Engineer-in-charge's request promptly increase the Performance security to a level of 10 percent of the increased Contract Price.</p>
	4.3.3	<p>The proceeds of the Performance Security shall be forfeited and shall be payable as compensation to the Procuring Entity on happening of any of the events mentioned below:</p> <ol style="list-style-type: none"> i. when the Contractor does not execute the agreement within the specified time; after issue of letter of acceptance/ placement of work order; or ii. when the Contractor fails to commence the work within the time specified; or iii. when the Contractor fails to complete the work satisfactorily within the time specified; or iv. when any terms and conditions of the contract is breached; or v. Failure by the Contractor to pay the Procuring Entity any amount due, either as agreed by the Contractor or determined under any of the Sub-Clauses of these Conditions or another agreement, within 30 Days of

		<p>the service of notice to this effect by Engineer-in-Charge; or</p> <p>vi. if the Contractor breaches any provision of the Code of Integrity prescribed for Bidders specified in the Act, the Rules, ITB Sub-Clause 1.3 and Sub-Clause 4.2.1 of these conditions.</p> <p>Notice of reasonable time will be given in case of forfeiture of Performance Security. The decision of the Procuring Entity in this regard shall be final.</p>
	4.3.4	<p>The Contractor shall ensure that the Performance Security remains valid up to a period 60 days beyond fulfilment of all the obligations of the Contractor under the Contract, including defect liability and maintenance, if any. If the terms of the Performance Security specify its expiry date, and the Contractor has not become entitled to receive the Performance Certificate by the date 28 Days prior to the expiry date as provided in the Contract, the Contractor shall get extended the validity of the Performance Security.</p> <p>Failure by the Contractor to extend the validity of the Performance security as described herein above, in which event the Engineer-in-charge may claim the full amount of the performance security.</p>
	4.3.5	<p>The Procuring Entity shall return the Performance Security or release the Performance Security Declaration to the Contractor as below after completion of all obligations under the Contract, more specifically, after the expiry of the period as specified below:</p> <p>i. In case of contracts relating to hiring of trucks and other T&P, transportation including loading, unloading of materials, the amount of Performance Security will be refundable along with the final bill.</p> <p>ii. Ordinary repairs: 3 months after the completion of the Works, provided the final bill has been paid.</p> <p>iii. Original Works / Special Repair Works: Performance Security will be refunded six months after completion, or after expiry of one full rainy season, or after expiry of defect liability period and maintenance period, if any specified in the Contract Data, whichever is later, provided the final bill has been paid.</p> <p>iv. In case of supply of materials: after 3 months of completion of supply, provided the final bill has been paid.</p> <p>v. In case of PWD original Works/ Special Repair</p>

		Works costing more than Rupees 100 lakh, partial amount of Performance Security will be refunded during the defect liability @ 10% of the Performance Security amount after the lapse of one year of completion and thereafter 10% of original amount of Performance Security at the end of each subsequent year. The remaining amount of Performance Security will be refunded after the satisfactory expiry of the defect liability period.
	4.3.6	In the event of the Contract being determined or rescinded under any of the provisions of Sub-Clause 16.1, the Performance Security shall stand forfeited in full and shall be absolutely at the disposal of the Procuring Entity.
	4.3.7	For works for which a maintenance period of 3-5 years is also specified in addition to the defect liability period. The regular maintenance shall be a part of the BOQ of the Contract as a lump sum amount per annum to be paid on quarterly basis. Necessary price escalation as per provisions in the Contract shall also be payable for years subsequent to the expiry of the Defect Liability Period.
Commencement of Work at the earliest. Record the commencement or start date.	4.4	The Contractor shall commence the Works after signing of the Contract within the period as specified in the Special Conditions of the Contract. In case the Contractor does not commence the works within the above period, the Engineer-in-charge shall issue a notice after the expiry of the said period. The actual date of commencement shall be duly recorded by the Engineer-in-Charge.
Contractor's Representative	4.5	Contractor shall appoint the Contractor's Representative and shall give him all authority necessary to act on the Contractor's behalf under the Contract. Unless the Contractor's Representative is named in the Contract, the Contractor shall, prior to the Commencement Date, submit to the Engineer-in-charge for consent the name and particulars of the person the Contractor proposes to appoint as Contractor's Representative. If consent is withheld or subsequently revoked in terms of this Sub-Clause, or if the appointed person fails to act as Contractor's Representative, or conducts improperly at the Site, the Contractor shall submit the name and particulars of another suitable person for such appointment. The former representative shall be removed within 24 hours of such notice by the Engineer-in-charge. The Contractor shall not, except if the representative has lost the confidence of the Contractor or is not complying to the instructions of the Engineer-in-charge or his assistants, remove without the prior consent of the Engineer-in-charge, revoke the

		<p>appointment of the Contractor's Representative or appoint a replacement.</p> <p>The whole time of the Contractor's Representative shall be given to directing the Contractor's performance of the Contract. If the Contractor's Representative is to be temporarily absent from the Site during the execution of the Works, a suitable replacement person shall be appointed, subject to the Engineer-in-charge's prior consent, and the Engineer-in-charge shall be notified accordingly. The Contractor's Representative shall, on behalf of the Contractor, receive instructions under Sub-Clause 3.3[Instructions of the Engineer-in-charge] and comply to them.</p> <p>The Contractor's Representative may delegate any powers, functions and authority to any competent person and may at any time revoke the delegation. Any delegation or revocation shall not take effect until the Engineer-in-charge has received prior notice signed by the Contractor's Representative, naming the person and specifying the powers, functions and authority being delegated or revoked. The Contractor's Representative shall be fluent in the language for communications defined in Sub-Clause 1.4.If the Contractor's Representative's delegates are not fluent in the said language, the Contractor shall make competent interpreters available during all working hours in a number deemed sufficient by the Engineer-in-charge.</p>
<p>Sub-Contractor, nominated Sub-Contractor.</p>	<p>4.6</p>	<p>The Contractor shall not Sub-let or subcontract the whole/ or even part of the Works without the consent of the Engineer-in-charge. If the Contractor does so, the Contract shall be liable to be terminated under Sub-Clause 16.1 [Termination by Procuring Entity]. Details of the capability of such proposed Sub-Contractors (except the nominated Sub-Contractor named by the Engineer-in-charge) shall be approved by the Engineer-in-charge. The Contractor shall be responsible for the misconduct, acts or defaults of any Sub contractor, his agents or employees, as if they were the acts or defaults of the Contractor.</p> <p>Unless otherwise stated:</p> <ul style="list-style-type: none"> i the Contractor shall not be required to obtain consent to suppliers solely of materials, or to a subcontract for which the nominated Sub contractor is named in the Contract. ii the prior consent/ approval of the Engineer-in-charge on capability documents of the sub-contract shall be obtained for proposed Sub-Contractor; iii the Contractor shall give the Engineer-in-charge not less than 28 Days' notice of the intended date of the commencement of each Sub-Contractor's work, and of the commencement of such work on the Site.

		The Contractor shall ensure that the requirements imposed on the Contractor regarding Confidentiality as defined in the GCC Sub-Clause 1.16 [Confidential Details] shall apply equally to each nominated Subcontractor / Subcontractor.
Co-Operation	4.7	<p>The Contractor shall, as specified in the Contractor as instructed by the Engineer-in-charge, allow appropriate opportunities for carrying out work to:</p> <ul style="list-style-type: none"> i) the Procuring Entity's Personnel, ii) any other Contractors employed by the Procuring Entity, and iii) the personnel of any legally constituted public authorities, <p>who may be employed in the execution on or near the Site of any work not included in the Contract.</p> <p>Any such instruction shall constitute a Variation if and to the extent that it causes the Contractor to suffer delays and/or to incur Unforeseeable Cost. Services for these personnel and other Contractors may include the use of Contractor's Equipment, Temporary Works or access arrangements which are the responsibility of the Contractor.</p> <p>If, under the Contract, the Procuring Entity is required to give to the Contractor, possession of any foundation, structure, plant or means of access in accordance with Contractor's Documents, the Contractor shall submit such documents to the Engineer-in-charge in the time and manner stated in the Specifications.</p>
Safety Procedures at the site of works	4.8.1	<p>The Contractor shall:</p> <ul style="list-style-type: none"> i. prepare and submit for approval by the Engineer-in-charge an auditable safety plan at Site in accordance with relevant Code. The Contractor shall comply with all applicable safety regulations; ii. take care for the safety of all persons entitled to be on the Site; iii. use reasonable efforts to keep the Site and Works clear of unnecessary obstruction so as to avoid danger to these persons; iv. provide fencing, lighting, guarding and watching of the works until completion and taking over under Sub-Clause 12.1 [Taking over of Works]; and v. provide any Temporary Works (including roadways, footways, guards and fences) which may be necessary, because of the execution of the Works, for the use and protection of the public and of owners and occupiers of adjacent land. <p>In addition to the provisions of this Contract, the Contractor shall follow the safety code of the Department.</p>
Safety Provisions for labour	4.8.2	In respect of all labour directly or indirectly employed, noncompliance in the work for the performance of the Contractor's part of this Contract, the Contractor shall at

		his own expense arrange for the safety provisions as per P.W.D. Safely Code framed from time to time and shall at his own expense provide for all facilities in connection therewith. In case the Contractor fails to make arrangement and provide necessary facilities as aforesaid, the Engineer-in-Charge shall be entitled to provide for all such arrangements at the risk and cost of the Contractor plus 15% as agency charges.
Quality Assurance	4.9.1	<p>The Procuring Entity shall have the right to exercise proper Quality Control measures to ensure that the works have been executed as per specifications and have the designed durability. It will be in three tiers:</p> <ol style="list-style-type: none"> i. The first tier being the Contractor's engineers ensuring full compliance to specifications and conforming the same through testing (as per frequencies specified in the BIS, IRC or other relevant codes) on input materials, processes and the output in the field laboratory established by the Contractor at his cost . ii. The second tier shall be the Engineer-in-charge's team conducting such tests to the extent of the specified code frequency at the Contractor's field laboratory or Department/ Organisation's laboratory and comparing the results with those carried out by the Contractor's Engineers; and iii. The third tier shall be the 'Third Party Quality Inspections' by the QCI approved / accredited Inspection Bodies as per ISO 17020, or by the Technical Examiner of the Department/ Organisation, where exists. The QCI approved / accredited Inspection Body may be selected through competitive bidding. The third tier shall conduct such tests to the extent of 10% of the specified frequencies duly witnessed by the Contractor's & Procuring Entity's Engineers and providing a final acceptability on the Works costing above Rs 10 crores for buildings and structures and Rs.20 crores for roads, bridges/ flyovers, canals, dams, etc. as specified in the SCC. <p>The Contractor shall provide all assistance to conduct such tests.</p>
	4.9.2	<p>The Contractor shall institute a approved quality assurance plan stating the methodology / responsibility for sampling, testing/ confirmatory testing, testing frequencies, statistical quality controls, observation / report formats, acceptance criteria, issue and resolution of Non Conformance Reports etc. to demonstrate compliance with the requirements of the specifications. The system shall be in accordance with the details stated in the Contract. The Engineer-in-charge shall be entitled to audit any aspect of the system.</p> <p>Details of all procedures and compliance documents shall</p>

		<p>be submitted to the Engineer-in-charge for information before each design and execution stage is commenced. When any document of a technical nature is issued to the Engineer-in-charge, evidence of the prior acceptance by the Contractor himself shall be apparent on the document itself.</p> <p>Compliance with the quality assurance system shall not relieve the Contractor of any of his duties, obligations or responsibilities under the Contract.</p>
Site Data	4.10.1	<p>The Procuring Entity shall have made available to the Contractor for his information, prior to the Base Date, all relevant data in the Procuring Entity's possession on sub-surface and hydrological conditions at the Site, including environmental aspects. The Procuring Entity shall similarly make available to the Contractor all such data which come in to the Procuring Entity's possession after the Base Date. The Contractor shall be responsible for verifying and interpreting all such data. The Procuring Entity shall not be held responsible about the correctness of all such data and the Contractor shall confirm/ verify all such data at his own cost.</p>
	4.10.2	<p>To the extent which was practicable (taking account of Cost and time), the Contractor shall be deemed to have obtained all necessary information as to risks, contingencies and other circumstances which may influence or affect the Bid for Works. To the same extent, the Contractor shall be deemed to have inspected and examined the Site, its surroundings, the above data and other available information, and to have been satisfied before submitting the Bid as to all relevant matters, including (without limitation):</p> <ul style="list-style-type: none"> i the form and nature of the Site, including sub-surface conditions, ii the hydrological and climatic conditions, iii the extent and nature of the work and goods necessary for the execution and completion of the Works and the remedying of any Defects, iv the Laws, procedures and labour practices of India, particularly Rajasthan, and v the Contractor's requirements for access, accommodation, facilities, personnel, power, transport, water and other services.
Sufficiency of the Contracted Amount	4.11	<p>The Contractor shall be deemed to:</p> <ul style="list-style-type: none"> i. have satisfied himself as to the correctness and sufficiency of the Accepted Contract Amount, and ii. have based the Accepted Contract Amount on the data, interpretations, necessary information, inspections, examinations and satisfaction as to all relevant matters referred to in Sub-Clause 4.10[Site Data].

		<p>Unless otherwise stated in the Contract, the Accepted Contract Amount covers all the Contractor's obligations under the Contract (including those under Provisional Sums, if any) and all things necessary for the proper execution and completion of the Works and the remedying of any Defects.</p>
Unforeseeable Physical Conditions	4.12	<p>In this Sub-Clause, "physical conditions" means natural physical conditions and man-made and other physical obstructions and pollutants, which the Contractor encounters at the Site when executing the Works, including sub-surface and hydrological conditions but excluding climatic conditions.</p> <p>If the Contractor encounters adverse physical conditions which the Procuring Entity considers to have been Unforeseeable, the Contractor shall give notice to the Engineer-in-charge as soon as practicable.</p> <p>This notice shall describe the physical conditions, so that they can be inspected by the Engineer-in-charge, and shall set out the reasons why the Contractor considers them to be Unforeseeable. The Contractor shall continue executing the Works, using such proper and reasonable measures as are appropriate for the physical conditions, and shall comply with any instructions which the Engineer-in-charge may give. If an instruction constitutes a Variation, Clause 9 [Deviations, Variations and Adjustments] shall apply.</p> <p>If and to the extent that the Contractor encounters physical conditions which are Unforeseeable, gives such a notice, and suffers delay and/ or incurs Cost due to these conditions, the Contractor shall be entitled subject to notice under Sub-Clause 21.2 [Contractor's Claims] to:</p> <ol style="list-style-type: none"> i. an extension of time for any such delay, if completion is or will be delayed, under Sub-Clause 8.6 [Extension of Time for Completion], and ii. payment of any such Cost, directed to be incurred by the Contractor as approved extra item which shall be included in the Contract Price. <p>Upon receiving such notice and inspecting and/or investigating these physical conditions, the Engineer-in-charge shall proceed in accordance with Sub-Clause 3.5 [Determinations] to agree or determine whether and (if so) to what extent these physical conditions were Unforeseeable, and the matters described in sub-paragraphs (i) and (ii) above related to this extent by the Contractor, but the Engineer-in-charge shall not be bound by the Contractor's interpretation of any such evidence.</p> <p>However, before additional Cost is finally agreed or determined under sub-paragraph (ii), the Engineer-in-charge may also review whether other physical conditions in similar parts of the Works (if any) were more favourable</p>

		than could reasonably have been foreseen when the Contractor submitted the Bid. If and to the extent that these more favourable conditions were encountered, the Engineer-in-charge may proceed in accordance with Sub-Clause 3.5 [Determinations] to agree or determine the reductions in Cost which were due to these conditions, which may be included (as deductions) in the Contract Price and Payment Certificates. However, the net effect of all adjustments under sub-paragraph (ii) and all these reductions, for all the physical conditions encountered in similar parts of the Works, shall not result in a net reduction in the Contract Price.
Right of Way and Facilities	4.13.1	Unless otherwise specified in the Contract the Procuring Entity shall provide access to and possession of the Site including special and/or temporary rights-of-way which are necessary for the Works. The Contractor shall obtain, at his risk and Cost, any additional rights of way or facilities outside the Site which he may require for the purposes of the Works.
	4.13.2	The Contractor shall allow the Engineer-in-charge and any person authorized by the Engineer-in-charge access to the Site, to any place where work in connection with the Contract is being carried out or is intended to be carried out and to any place where materials are being collected or stored or plant are being installed/ assembled for the Works. The contractor may satisfy himself regarding site, acquisition of land, approach roads etc.
Avoidance of Interference with public conveniences	4.14	The Contractor shall not interfere unnecessarily or improperly with: <ul style="list-style-type: none"> i. the convenience of the public, or ii. the access to and use and occupation of all roads and footpaths, irrespective of whether they are public or in the possession of the Procuring Entity or of others The Contractor shall indemnify and hold the Procuring Entity harmless against and from all damages, losses and expenses (including legal fees and expenses) resulting from any such unnecessary or improper interference.
Access Routes to Site	4.15	The Contractor shall be deemed to have been satisfied as to the suitability and availability of access routes to the Site at Base Date. The Contractor shall use reasonable efforts to prevent any road or bridge from being damaged by the Contractor's traffic or by the Contractor's Personnel. These efforts shall include the proper use of appropriate vehicles and routes. Except as otherwise stated in these Conditions: <ul style="list-style-type: none"> i the Contractor shall (as between the Parties) be responsible for any maintenance which may be required for his use of access routes; ii the Contractor shall provide all necessary signs or

		<p>directions along access routes, and shall obtain any permission which may be required from the relevant authorities for his use of routes, signs and directions;</p> <p>iii the Procuring Entity shall not be responsible for any claims which may arise from the use or otherwise of any access route;</p> <p>iv the Procuring Entity does not guarantee the suitability or availability of particular access routes; and</p> <p>v Costs due to non-suitability or non-availability, for the use required by the Contractor, of access routes shall be borne by the Contractor.</p>
Contractor's Equipment	4.16	The Contractor shall be responsible for all Contractor's Equipment. When brought on to the Site, Contractor's Equipment shall be deemed to be exclusively intended for the execution of the Works. The Contractor shall not remove from the Site any major items of Contractor's Equipment without the consent of the Engineer-in-Charge. However, consent shall not be required for vehicles transporting Goods or Contractor's Personnel offsite.
Protection of the Environment	4.17	<p>The Contractor shall take all reasonable steps to protect the environment (both on and off the Site) and to limit damage and nuisance to people and property resulting from pollution, noise and other results of his operations.</p> <p>The Contractor shall ensure that emissions, surface discharges and effluent from the Contractor's activities shall not exceed the values stated in the Specifications or prescribed by applicable Laws.</p> <p>The Contractor shall, throughout the execution and completion of the Works and the remedying of any Defects therein:</p> <p>i. have full regard for the safety of all persons entitled to be upon the Site and keep the Site (so far as the same is under his control) and the Works (so far as the same are not completed or occupied by the Procuring Entity) in an orderly state appropriate to the avoidance of danger to such persons; and</p> <p>ii. provide and maintain at his own Cost all lights, guards, fencing, warning signs and watchmen and other things necessary or required by the Engineer-in-charge or by any duly constituted authority, for the protection of the Works or for the safety and convenience of the public or others.</p>
Electricity, Water and Gas	4.18	<p>The Contractor shall, except as stated below, be responsible for the provision of all power, water and other services he may require for his construction activities and to the extent defined in the Specifications, for the tests.</p> <p>The Contractor shall be entitled to use for the purposes of the Works such supplies of electricity, suitable water, gas and other services as may be available on the Site with due permission of the service provider, on payment of</p>

		<p>billing value. The Contractor shall, at his risk and cost, provide any apparatus necessary for his use of these services and for measuring / paying for the quantities consumed.</p> <p>The quantities consumed and the amounts due for such services shall be agreed or determined by the Engineer-in-Charge in accordance with Sub-Clause 2.5 [Procuring Entity's Claims] and Sub-Clause 3.5 [Determinations]. The Contractor shall pay these amounts to the Procuring Entity /service provider.</p>
<p>Issue of Procuring Entity's Equipments and Materials</p> <p><i>(Not applicable in case of Lump Sum Contract)</i></p>	<p>4.19</p>	<p>i The Procuring Entity may on request issue its machinery and equipment on hire to the Contractor, if available, for the use in the execution of the Works. The hire charges shall be as provided in the Contract Data or on the rates declared by the Procuring Entity in general.</p> <p>The Procuring Entity shall hand over the equipment in good working condition duly confirmed by the Contractor at the time of issue, along with departmental operators, helpers. The Contractor shall be responsible for the proper operation and care of the Procuring Entity's Equipment, POL, washout and ordinary repairs Contractor's operators shall not operate the equipment and the rentals / hire and other charges shall be deposited in advance for every 15 days by the Contractor failing which these shall be recovered from the immediately next Interim payment due to the Contractor.</p> <p>ii The Procuring Entity may issue materials like cement, steel, etc.(if available) to the Contractor for bonafide use in the Works at the rates specified in the Contract Data or at issue rate plus storage charges or free of cost, if it is a labour rate Contract, at the time and place specified in the Contract. <i>Such materials shall be issued at different stages in quantities calculated for each stage by the Engineer-in-Charge.</i></p>
<p>Progress Reports</p>	<p>4.20</p>	<p>Unless otherwise stated in the Conditions, monthly progress reports shall be prepared by the Contractor and submitted to the Engineer-in-charge in specified number of copies along with the interim payment certificates, and the updated construction programme on MS Project or similar software for the next month. The first report shall cover the period up to the end of the first calendar month following the Commencement Date. Reports shall be submitted monthly thereafter, each within 7 Days after the last day of the month to which it relates. Reporting shall continue until the Contractor has completed all works which is known to be out standing at the completion date stated in the Taking-Over Certificate for the Works.</p> <p>Each report shall include:</p>

		<ul style="list-style-type: none"> i charts, drawings, outputs and detailed descriptions of progress, including each stage of design (if any) on MS project or similar software, Contractor's Documents, procurement, manufacture, delivery to Site, construction, erection and testing; and including these stages for work by each nominated Subcontractor(as defined in Sub-Clause 5.2 [Nomination of Sub-Contractors]); ii photographs (in adequate numbers) showing the status of progress of works on the Site; iii the details described in Sub-Clause 6.12 [Records of Contractor's Personnel & Equipment]; iv copies of quality assurance documents, test results, test certificates of manufactured Materials and action taken on Third Party Quality Inspections by the Contractor; v list of notices given under Sub-Clause 2.5 [Procuring Entity's Claims] and notices given under Sub-Clause 21.2 [Contractor's Claims]; vi safety statistics, including details of any hazardous incidents and activities relating to environmental aspects and public relations; and vii comparisons of actual and planned progress, hindrances, with details of any events or circumstances which may jeopardize the completion in accordance with the Contract, and the measures being (or to be) adopted to overcome delays.
<p>Security of the Site and Works</p>	<p>4.21</p>	<p>Unless otherwise stated in the Conditions:</p> <ul style="list-style-type: none"> i the Contractor shall be responsible for keeping unauthorized persons off the Site, ii authorized persons shall be limited to the Contractor's Personnel and the Procuring Entity's Personnel; and to any other personnel notified to the Contractor by the Procuring Entity or the Engineer-in-charge, as authorized personnel of the Procuring Entity's other Contractors on the Site. iii The contractor shall arrange to protect, at his own cost, in an adequate manner, all cut stone work and other work, requiring protection and to maintain such protection as long as work is in progress. He shall remove and replace this protection, as required by the Engineer-in-charge, from time to time. Any damage to the work, so protected, no matter how it may be caused, shall be made good by the Contractor free of cost. All templates, forms. Moulds, centering, false works and models which in the opinion of the Engineer-in-charge are necessary for the proper and workman like execution of the work, shall be provided by the Contractor free of cost. iv The Contractor shall arrange to keep the site and works secure from manmade disasters, explosions by design or by accident or both at his own cost.

Contractor's Operations on Site	4.22	<p>The Contractor shall confine his operations to the Site, and to any additional areas which may be obtained by the Contractor and agreed to by the Engineer-in-charge as additional working areas. The Contractor shall take all necessary precautions to keep Contractor's Equipment and Contractor's Personnel within the Site and these additional areas, and to keep them off adjacent land.</p> <p>During the execution of the Works, the Contractor shall keep the Site free from all unnecessary obstruction, and shall store or dispose of any Contractor's Equipment or surplus Materials. The Contractor shall clear away and remove from the Site any wreckage, rubbish and Temporary Works which are no longer required.</p> <p>When the annual repairs and maintenance of Works are carried out, the splashes and droppings from white washing, color washing, painting etc. on walls, floor, windows etc. shall be removed and the surface cleaned simultaneously with the completion of these items of work in the individual rooms, quarters or premises etc. where the work is done without waiting for the actual completion of all the other items of work in the Contract. In case the Contractor fails to comply with the requirements of this Sub-Clause, the Engineer-in-Charge shall have the right to get this work done at the Cost of the Contractor either Departmentally or through any other agency. Before taking such action, the Engineer-in-Charge shall give ten Day's notice in writing to the Contractor.</p> <p>Upon the issue of a Taking-Over Certificate, the Contractor shall clear away and remove, from that part of the Site and Works to which the Taking-Over Certificate refers, all Contractor's Equipment, surplus material, wreckage, rubbish and Temporary Works. The Contractor shall leave that part of the Site and the Works in a clean and safe condition. However, the Contractor may retain on Site, during the Defects Notification Period, such goods, equipment as are required by the Contractor to fulfill obligations under the Contract.</p>
Fossils/ antiques and articles of value	4.23	<p>All fossils, coins, articles of value or antiquity, and structures and other remains or items of geological or archaeological interest found on the Site shall be placed under the care and authority of the Engineer-in-charge / Procuring Entity. The Contractor shall take reasonable precautions to prevent Contractor's Personnel or other persons from removing or damaging any of these findings.</p> <p>The Contractor shall, upon discovery of any such finding, promptly give notice to the Engineer-in-charge, who shall issue instructions for dealing with it. If the Contractor suffers delay and/or incurs Cost from complying with the instructions, the Contractor shall give a further notice to the Engineer-in-charge and shall be entitled subject to Sub-Clause 21.2 [Contractor's Claims] to:</p>

		<p>i. an extension of time for any such delay, if completion is or will be delayed, under Sub-Clause 8.6 [Extension of Time for Completion]; and</p> <p>ii. Payment of any such Cost, which shall be included in the Contract Price. After receiving this further notice, the Engineer-in-charge shall proceed in accordance with Sub-Clause 3.5 [Determinations] to agree or determine these matters.</p>
Completion Plans to be Submitted by the Contractor	4.24	<p>The Contractor shall submit completion drawings, designs within thirty Days of the virtual completion of the Works.</p> <p>In case, the Contractor fails to submit the completion drawings, designs as aforesaid, the Engineer-in-charge shall be authorised to get these as built drawings, designs and other data prepared in 6 copies (4 hard and two soft) at the cost of the Contractor.</p>
Contractor to Supply Tools & Plants etc.	4.25	<p>The Contractor shall provide at his own Cost all materials plant, tools, appliances, implements, ladders, cordage, tackle, scaffolding and Temporary Works required for the proper execution of the Works, whether original, altered or substituted and whether included or not in the Specification or other documents forming part of the Contractor referred to in these conditions, or which may be necessary for the purpose of satisfying or complying with the requirements of the Engineer-in-Charge as to any matter as to which under these conditions he is entitled to be satisfied, or which he is entitled to require together with carriage therefore to and from the Works.</p> <p>The Contractor shall also supply without charge the requisite number of persons with the means and materials, necessary for the purpose of setting out Works, and counting, weighing and assisting the measurement for examination at any time and from time to time of the work or Materials. Failing his so doing the same may be provided by the Engineer-in-Charge at the actual Cost +15% as agency charges to the Contractor, under this Contract or otherwise and/ or from his Performance Security or the proceeds of sale thereof, or of a sufficient portion thereof.</p>
Changes in the firm's constitution to be intimated	4.26	<p>Where the Contractor is a partnership firm, the previous approval in writing of the Engineer-in-Charge shall be obtained before any change is made in the constitution of the firm. Where the Contractor is an individual or a Hindu undivided family business concern such approval as aforesaid shall likewise be obtained before the Contractor enters into any partnership agreement where under the partnership firm would have the right to carry out the Works hereby undertaken by the Contractor. If previous approval as aforesaid is not obtained, the Contract shall be deemed to have been subcontracted in contravention of Sub-Clause 4.6 [Sub-Contractor, nominated Sub-Contractor] and the same action may be taken and the same consequences shall ensue as provided in the Sub-Clause</p>

		16.1 [Termination by Procuring Entity]
5. Sub-Contractor and Nomination of Sub-Contractor		
Sub Contractor	5.1	A Sub Contractor, if permitted under the Contract, is a firm or a person specified by the Contractor in his Bid along with details of his capabilities on equipment/ machineries, personnel (technical and others), experience on similar works specific to the project, commitment to Quality assurance etc. He should not have been debarred by the Procuring Entity or the State Government.
Nomination of Sub-Contractor	5.2	In the Contract, “nominated Sub-Contractor” means a Sub-Contractor: (a) who is stated in the Contract as being a nominated Sub-contractor, or (b) whom the Engineer-in-charge, instructs the Contractor to employ as a Sub contractor subject to Sub-Clause 5.3 [Objection to Nomination].
Objections to nominations	5.3	The Contractor or shall not be under any obligation to employ a nominated Sub-contract or against whom the Contract or raises reasonable objection by notice to the Engineer-in-charge as soon as practicable, with supporting particulars.
Payment to Nominated Sub-Contractor	5.4	The Contractor shall pay to the Nominated Sub-Contractors the amounts shown on the Nominated Sub-contractor’s invoices approved by the Contractor which the Engineer-in-charge certifies to be due in accordance with the sub-contract. These amounts plus other charges paid to the Nominated Sub-Contractor shall be included in the Contract Price in accordance with Sub-Clause 9.6 [Provisional Sums].
Evidence of payments	5.5	Before issuing a Payment Certificate which includes an amount payable to a nominated Subcontractor, the Engineer-in-Charge may request the Contractor to supply reasonable evidence that the nominated Subcontractor has received all amounts due in accordance with previous Payment Certificates, less applicable deductions for retention or otherwise. Unless the Contractor: (a) submits this reasonable evidence to the Engineer-in-Charge, or (b) (i) satisfies the Engineer-in-Charge in writing that the Contractor is reasonably entitled to withhold or refuse to pay these amounts, and (ii) submits to the Engineer-in-Charge reasonable evidence that the nominated Subcontractor has been notified of the Contractor’s entitlement, then the Procuring Entity may (at his sole discretion) pay, direct to the nominated Subcontractor, part or all of such amounts previously certified (less applicable

		deductions) as are due to the nominated Subcontractor and for which the Contractor has failed to submit the evidence described in sub-paragraphs (a) or (b) above. The Contractor shall then repay, to the Procuring Entity, the amount which the nominated Subcontractor was directly paid by the Procuring Entity.
6. Engagement of Staff and Labour by the Contractor		
Staff and Labour	6.1	<p>i. Except as otherwise stated in the Specifications, the Contractor shall make arrangements for the engagement of all staff and labour, local or otherwise, and for their payment, water, power, healthcare backup, transport and, when appropriate, housing.</p> <p>ii. The Contractor is encouraged, to the extent practicable and reasonable, to employ staff and labour with appropriate qualifications and experience from sources within India.</p> <p>iii. No Engineer of gazetted rank or other gazetted officer employed in Engineering or administrative duties in an Engineering Department of the Government of Rajasthan shall work as a Contractor or employee of a Contractor for a period of two years after his retirement from Government service without the previous permission of State Government in writing. The Contract is liable to be cancelled if either the Contractor or any of his employees is found at any time to be such a person who had not obtained said permission prior to engagement in the Contractor's service, as the case may be.</p>
Bidder barred from bidding if near Relatives working in Procuring Entity's office	6.2	<p>The Contractor shall not be permitted to bid for works of a Procuring Entity in which his near relative is an employee. He shall also not have a person as his employee who is a near relative of an employee of the Procuring Entity. Any breach of this condition by the Contractor shall be considered as breach of Code of Integrity and shall render him liable to action under Section 11(3) of the Act which includes exclusion of his Bid from procurement process, forfeiture of Bid Security, Performance Security or any other security or bond relating to procurement, recovery of payments made, if any, along with interest at bank rate, cancellation of the Contract, if already made, debarment from future bidding for a period upto three years, etc.</p> <p>Note: By the term 'near relative' is meant wife, husband, parents and grand- parents, children and grand- children, brothers and sisters, uncles and cousins and their corresponding in- laws.</p>

Employment of Technical Staff and other Employees	6.3.1	The Contractor shall Engage technical personnel as per list provided for in the Contract and provide all necessary superintendence during execution of the Works and as long thereafter as may be necessary for proper fulfilling of the obligations under the Contract. The project manager of the Contractor shall be his principal technical representative. Other personnel shall be engaged as specified in the qualification criteria.
	6.3.2	The technical staff should always be available at site whenever required by Engineer- in- charge to take instructions. The Contractor shall comply with the provisions of the Apprenticeship Act, 1961, and the Rules and Orders issued, there under, from time to time. If he fails to do so, his failure will be a breach of Contract. The Contractor shall also be liable for any pecuniary liability arising on account of any violation by him of the provisions of the said Act.
Responsibility of the Technical Staff and employees	6.4	Technical officers/ staff deployed by the Contractor at any construction Site will be responsible for proper quality of Works and physical targeted progress of the Works.
Rate of Wages and Conditions of Labour	6.5	The Contractor shall not pay less than fair wages/ minimum wages to labourers engaged by him on the Works as revised from time to time by the State Government, but the Procuring Entity shall not be liable to pay anything extra for it except as stipulated in price escalation Sub-Clause of the agreement. Explanation: "Fair Wage" means minimum wages for time or piece work, fixed or revised, by the State Government under the Minimum Wages Act, 1948. The Contractor shall, notwithstanding the provisions of any contract to the contrary, cause to be paid fair wages to labourers directly or indirectly engaged on the Works, including any labour engaged by his Sub-Contractors in connection with the said Works as if the labourers have been immediately or directly employed by him. In respect of all labourers, immediately or directly employed on the Works, for the purpose of Contractor's part of this agreement, the Contractor shall comply with or cause to be complied with the Public Works Department Contractor's Labour Regulations made, or that maybe made by the State Government from time to time in Regard to payment of wages, wage period, deductions from wages, recovery of wages not paid, and unauthorized deductions, maintenance of wages register, wage card, publication of scale of wages and other terms of employment, inspection and submission of periodical returns and other matters of a like nature. The Engineer-in-charge shall have the right to deduct from the money due to the Contractor any sum required or estimated to be required for making good the loss suffered

		<p>by a worker or workers, by reasons of non-fulfillment of the conditions of the Contract, for the benefit of the worker or the workers, non-payment of wages or of deductions made there from, which are not justified by the terms of the Contract, or as a result of non-observance of the aforesaid regulations.</p> <p>Vis-à-vis the State Government of Rajasthan, the Contractor shall be primarily liable for all payments to be made and for the observance of the regulations aforesaid, without prejudice to his right to claim indemnity from his Sub-Contractors.</p> <p>The regulations, aforesaid, shall be deemed to be part of this Contract and any breach, thereof, shall be deemed to be breach of the Contract.</p>
Contractor not to engage staff of Procuring Entity	6.6	The Contractor shall not recruit, or attempt to recruit, full time (on leave) or part time the staff and labour from amongst the Procuring Entity's Personnel in any capacity.
Working Hours	6.7	<p>No work shall be carried out on the Site on locally recognized Days of rest, or outside the normal working hours stated in the Contract Data, unless:</p> <ul style="list-style-type: none"> i otherwise stated in the Contract, ii. the Engineer-in-charge gives consent, or iii the work is unavoidable, or necessary for the protection of life or property or for the safety of the Works, in which case the Contractor shall immediately advise the Engineer-in-charge.
Facilities for Staff and Labour	6.8	<p>Except as otherwise stated in the Specifications, the Contractor shall provide and maintain all necessary accommodation and welfare facilities for the Contractor's Personnel. The Contractor shall also provide work site facilities for the Procuring Entity's Personnel as stated in the Specifications.</p> <p>The Contractor shall not permit any of the Contractor's Personnel to maintain any temporary or permanent living quarters within the structures forming part of the Permanent Works.</p>
Health & Safety	6.9	<p>The Contractor shall at all times take all reasonable precautions to maintain the health and safety of the Contractor's Personnel. In collaboration with local health authorities, the Contractor shall ensure that medical staff, first aid facilities, sick bay, doctor at call and ambulance service are available at all times at the Site and at any accommodation for Contractor's and Procuring Entity's Personnel, and that suitable arrangements are made for all necessary welfare and hygiene requirements and for the prevention of epidemics.</p> <p>The Contractor shall appoint a safety officer at the Site, responsible for maintaining safety and protection against accidents. This person shall be qualified and trained for</p>

		<p>this responsibility, and shall have the authority to issue instructions and take protective measures to prevent accidents. Throughout the execution of the Works, the Contractor shall provide whatever is required by this person to exercise this responsibility and authority.</p> <p>The Contractor shall send, to the Engineer-in-charge, details of any accident occurred at the Site or to or due to the Works, as soon as practicable after its occurrence. The Contractor shall maintain records and make reports concerning health, safety and welfare of persons, and damage to property, as the Engineer-in-charge may reasonably require.</p>
Contractor's Superintendence	6.10	<p>Throughout the execution of the Works, and as long thereafter as is necessary to fulfil the Contractor's obligations, the Contractor shall provide all necessary superintendence to plan, arrange, direct, manage, inspect and test the Works.</p> <p>Superintendence shall be given by a sufficient number of persons having adequate knowledge of the language for communications (defined in Sub-Clause 1.4 [Law and Language] and of the operations to be carried out (including the methods and techniques required, the hazards likely to be encountered and methods of preventing accidents), for the satisfactory and safe execution of the Works.</p>
Contractor's Personnel	6.11	<p>Contractor's Personnel shall be appropriately qualified, skilled and experienced in respective trades or occupations. The Engineer- in-charge may require the Contractor to remove (or cause to be removed) any person employed on the Site or Works, including the Contractor's Representative, if applicable, who:</p> <ol style="list-style-type: none"> i. persists in any misconduct or lack of care, ii carries out duties incompetently or negligently, iii. fails to conform with any provisions of the Contract, or iv. Persists in any conduct which is prejudicial to safety, health, or the protection of the environment. <p>If appropriate, the Contractor shall then appoint (or cause to be appointed) a suitable replacement person.</p>
Records of Contractor's personnel and Equipment	6.12	<p>The Contractor shall provide all required equipment, machinery at the Site and submit to the Engineer-in-charge, details showing the number of each category of Contractor's Personnel and of each type of Contractor's Equipment on the Site. Details shall be submitted each calendar month, in a form approved by the Engineer-in-charge, until the Contractor has completed all work which is known to be outstanding at the completion date stated in the Taking-Over Certificate for the Works.</p>
Disorderly Conduct	6.13	<p>The Contractor shall at all times take all reasonable precautions to prevent any unlawful, riotous or disorderly conduct by or amongst the Contractor's Personnel, and to preserve peace and protection of persons and property on</p>

		and near the Site.
Foreign Personnel	6.14	Is permitted, the Contractor may bring in to the Country any foreign personnel who are necessary for the execution of the Works to the extent allowed by the applicable Laws. The Contractor shall ensure that these personnel are provided with the required residence visas and work permits. The Procuring Entity will, if requested by the Contractor, use his best endeavours in a timely and expeditious manner to assist the Contractor in obtaining any local, state, national, or Government permission required for bringing in the Contractor's personnel. The Contractor shall be responsible for the return of these personnel to the place where they were recruited or to their domicile. In the event of the death in the Country of any of these personnel or members of their families, the Contractor shall similarly be responsible for making the appropriate arrangements for their return or burial.
Supply of Food Stuffs	6.15	The Contractor shall arrange for the provision of a sufficient supply of suitable food stuff as may be stated in the Specification at reasonable prices for the Contractor's Personnel for the purposes of or in connection with the Contract.
Supply of Water	6.16	The Contractor shall, having regard to local conditions, provide at his cost on the Site an adequate supply of potable drinking and other water for use in construction and for use of the Contractor's Personnel.
Measures against Insect and Pest Nuisance	6.17	The Contractor shall at all times take the necessary precautions to protect the Contractor's Personnel employed on the Site from insect and pest nuisance, and to reduce their danger to health. The Contractor shall comply with all the regulations of the local health authorities, including use of appropriate insecticide.
Alcoholic Liquor or Drugs	6.18	The Contractor shall not, otherwise than in accordance with the Laws of the Country, import, sell, give, barter or otherwise dispose of any alcoholic liquor or drugs, or permit or allow importation, sale, gift, barter or disposal there to by Contractor's Personnel. He shall also not allow the consumption of such Alcoholic Liquor/Drugs at Site during working hours.
Arms and Ammunition	6.19	The Contractor shall not give, barter, or otherwise dispose of, to any person, any arms or ammunition of any kind, or allow Contractor's Personnel to do so.
No unlicensed storage of Explosives and POL	6.20	The Contractor is not authorised to store explosives and POL or other inflammable materials without a valid license from the competent legal authority.

Prohibition of Forced or Compulsory labour	6.21	The Contractor shall not employ forced or compulsory labour, which consists of any work or service, not voluntarily performed, that is exacted from an individual under threat of force or penalty, and includes any kind of involuntary or compulsory labour, such as indentured labour, bonded labour or similar labour-contracting arrangements.
Prohibition of Child Labour	6.22	The Contractor shall comply with the provisions of Acts and rules pertaining to prohibition of employment of child labour including not employing any child to perform any work that is economically exploitative, or is likely to be hazardous to, or to interfere with, the child's education, or to be harmful to the child's health or physical, mental, spiritual, moral, or social development.
Festivals and Religious Customs	6.23	The Contract or shall respect the Country's recognized festivals, days of rest and religious or other customs.
Employment Records of Workers	6.24	The Contractor shall keep complete and accurate records of the employment of labour at the Site. The records shall include the names, ages, genders, hours worked and wages paid to all workers. These records shall be summarized on a monthly basis and submitted to the Engineer-in-charge, and these records shall be available for inspection by Auditors / labour inspectors and others as per law during normal working hours. These records shall be included in the details to be submitted by the Contractor under Sub-Clause 6.12 [Records of Contractor's Personnel and Equipment].
Compliance with Labour Laws	6.25	<p>The Contractor shall comply with all the relevant labour Laws applicable to the Contractor's Personnel, including Laws relating to their employment, health, safety, welfare, immigration and emigration, and shall allow them all their legal rights. The Contractor shall require his employees to obey all applicable Laws, including those concerning safety at work.</p> <p>The Contractor shall obtain a valid license under the State Labour Act, and the Contract Labour (Regulation and Abolition) Central Rules 1961, before the commencement of the Works, and continue to have a valid license until the completion of the Works. The Contractor shall also abide by the provisions of the Child Labour (Prohibition and Regulation) Act, 1986.</p> <p>The Contractor shall also comply with the provisions of the Building and Other Construction Workers (Regulation of Employment & Conditions of Service) Act, 1996 and the Building and Other Construction Workers Welfare Cess Act, 1996.</p>

Payment of Wages	6.26	<ul style="list-style-type: none"> i The Contractor shall pay to labour employed by him either directly or through Sub-Contractors, wages not less than fair wages as defined in P.W.D. Contractor's Labour Regulations or as per the provisions of the Contract Labour (Regulation and Abolition) Act 1970 and the Contract Labour (Regulation and Abolition) Central Rules, 1971, where applicable. ii The Contractor shall, notwithstanding the provisions of any Contract to the contrary, cause to be paid for wages to labour indirectly engaged on the Works including any labour engaged by his sub-Contractors in connection with the said Works, as if the labour had been immediately employed by him.
Penalty for non-compliance with labour Laws	6.27	<ul style="list-style-type: none"> i In respect of all labour directly or indirectly employed in the Works of performance of the Contractor's Part of this Contract, the contractor shall comply with or cause to be complied with the Public Works Department Contractor's Labour Regulations made by the Government from time to time in regard to payment of wages, wage period, deductions from wages, recovery of wages not paid and deductions unauthorisedly made, maintenance of wage books or wage slips, publication of scale of wages and other terms of employment, inspection and submission of periodical returns and all other matters of the like nature as per the Provisions of Contract Labour (Regulation & Abolition) Act, 1970, and the Contract Labour (Regulation & Abolition) Central Rules, 1971, wherever applicable. ii The Engineer-in-Charge concerned shall have the right to deduct from the moneys due to the Contractor any sum required or estimated to be required for making good the loss suffered by a worker or workers by reason of non-fulfilment of the conditions of the Contract for the benefit of the workers, non-payment of wages or of deductions, made from his or their wages which are not justified by their terms of the Contract or non-observance of the Regulations. iii Under the provision of Minimum Wages (Central) Rules 1950, the Contractor is bound to allow to the labour directly or indirectly employed in the Works one day rest for 6 Days continuous work and pay wages at same rate as for duty. In the event of default the Engineer-in-Charge shall have the right to deduct the sum or sums not paid on account of wages for weekly holidays to any labour and pay the same to the persons entitled thereto from any money due to the Contractor by the Engineer-in-Charge concerned.

		<p>iv The Contractor shall comply with the provisions of the Payment of Wages Act, 1936, Minimum Wages Act, 1948, Employees Liability Act, 1938, Workmen's Compensation Act, 1923, industrial Disputes Act, 1947, Maternity Act, 1970, or the modifications thereof or any other relevant Labour Laws and the rules made there under from time to time.</p> <p>v The Contractor shall indemnify and keep indemnified the State Government/ Procuring Entity against payments to be made under and for the observance of the Laws aforesaid and the P.W.D. Contractor's Labour Regulations without prejudice to his right to claim indemnity from his Sub-Contractors.</p> <p>vi The Laws aforesaid shall be deemed to be a part of this Contract and any breach thereof shall be deemed to be a breach of this Contract.</p> <p>vii Whatever is the minimum wage for the time being, or if the wage payable higher than the minimum wage, such wage shall be paid by the Contractor to the workmen directly without the intervention of Jamadar and that Jamadar shall not be entitled to deduct or recover any amount from the minimum wage payable to the workmen as and by way of commission or otherwise. The Contractor shall ensure that no amount by way of commission or otherwise is deducted or recovered by the Jamadar from the wage of workmen.</p>
7. Execution of works and workmanship		
Manner of Execution	7.1	<p>The Contractor shall carry out works, the production of mixes, the procurement of input materials, and all other execution of the Works:</p> <p>i in the manner (if any) specified in the Contract,</p> <p>ii in a proper workman like and careful manner, in accordance with recognized good practices, and</p> <p>iii with properly equipped facilities and non-hazardous materials, except as otherwise specified in the Contract.</p>
Samples	7.2	<p>The Contractor shall submit the following samples of Materials, and relevant information, to the Engineer-in-charge for consent prior to using the Materials in or for the Works:</p> <p>i Contractor's standard samples of raw/ produced Materials and samples specified in the Contract, all at the Contractor's Cost, and</p> <p>ii additional samples instructed by the Engineer-in-Charge as a Variation.</p> <p>Each sample shall be labelled as to origin and intended use in the Works.</p> <p>Samples shall also be collected by the Quality testing/inspection teams from the works in progress and</p>

		the Contractor shall willingly cooperate with such quality assurance procedures.
Inspection	7.3	<p>The Procuring Entity's Personnel shall at all reasonable times:</p> <ul style="list-style-type: none"> i have full access to all parts of the Site and to all places from which natural materials are being obtained, and ii during production, manufacture and construction (at the Site and elsewhere), be entitled to examine, inspect, measure and test the materials and workmanship, and to check the progress of manufacture of Plant and production and manufacture of materials. <p>The Contractor shall give the Procuring Entity's Personnel full opportunity to carry out these activities, including providing access, facilities, permissions and safety equipment. No such activity shall relieve the Contractor from any obligation or responsibility.</p> <p>The Contractor shall give notice of minimum 07 days to the Engineer-in-charge whenever any work is ready and before it is covered up, put out of sight, or packaged for storage or transport, beyond measurement, any work in order that the same may be measured and correct dimensions thereof, be taken before the same is covered up. The Engineer-in-charge shall then either carry out the examination, inspection, measurement or testing without unreasonable delay, or promptly give notice to the Contractor that the Engineer-in-charge does not require to do so. If the Contractor fails to give the notice, he shall, if and when required by the Engineer-in-charge, uncover the work and thereafter reinstate and make good, all at the Contractor's Cost.</p>
<p>Stores supplied by the Procuring Entity</p> <p><i>(Not applicable in case of Lump Sum Contract)</i></p>	7.4	<p>If the specification or estimate of the Works provide for the use of any special description of materials, to be supplied from the Engineer Incharge's stores, or if, it is required that Contractor shall use certain stores to be provided by the Engineer Incharge specified in the Schedule or Memorandum hereto annexed, the Contractor shall be bound to procure and shall be supplied such materials and stores as are, from time to time, required to be used by him for the purpose of the Contract only, and the value of the full quantity of materials and stores, so supplied, at the rates specified in the said Schedule or Memorandum, may be set off or which may be deducted from any sum, then due or thereafter become due, to the Contractor under the Contract or otherwise or against or from the Performance Security or the proceeds of sale, if the same is held in Government securities, the same or a sufficient portion thereof being in this case, sold for this purpose. All</p>

		<p>materials supplied to the Contractor, either from departmental stores or with the assistance of the Procuring Entity, shall remain the absolute property of the Procuring Entity. The Contractor shall be the trustee of the stores/ materials, so supplied/ procured and these shall not, on any account, be removed from the Site of the Works and shall be, all times, open to inspection by the Engineer Incharge. Any such materials, unused and in perfectly good condition at the time of completion or determination or rescinding of the Contract, shall be returned to the Engineer Incharge's Stores, if, by a notice in writing under his hand, he shall so require, and if on service of such notice, the Contractor fails to return the materials, so required, he shall be liable to pay the price of such materials. But the Contractor shall not be entitled to return any such materials, unless with such consent, and shall have no claim for compensation on account of any such materials, so supplied to him as aforesaid being unused by him, or for any wastage in or damage to any such materials. For the stores returned by the Contractor, he shall be paid for, at the price originally charged excluding storage charges, in case of materials supplied from departmental stores and actual cost including freight, cartage, taxes etc., paid by the Contractor, in case of supplies received with the assistance of the Procuring Entity, however, should in no case exceed market rate prevailing at the time the materials are taken back. The decision of the Engineer Incharge, as to the price of the stores returned, keeping in view its condition etc., shall be final and conclusive. In the event of breach of the aforesaid condition, the Contractor shall, in addition to throwing himself open to account for contravention of the terms of the license or permit and/or for criminal breach of trust, pay to the Procuring Entity, all advantages or profits resulting or which in the usual course, would result to him by reason of such breach. Provided that the Contractor shall, in no case be entitled to any compensation or damage on account of any delay in supply, or non-supply thereof, all or any such materials and stores.</p>
<p>Penal rate in case of excess consumption <i>(Not applicable in case of Lump Sum Contract)</i></p>	7.5	<p>The Contractor shall return the materials issued free of cost to him and found surplus after its intended consumption in the Works, immediately. The Contractor shall be charged for the materials which were not returned or consumed in excess of the requirements calculated on the basis of standard consumption approved by the Procuring Entity, at double of the issue rate including storage and supervision charges or market rate, whichever is higher. A Materials Supply and Consumption Statement, in prescribed Form RPWA 35A, shall be submitted with every Payment Certificate, distinguishing materials supplied by the Procuring Entity and materials</p>

		procured by the Contractor himself. The recovery for such materials shall be made from Payment Certificate next after the consumption and shall not be deferred. Certificate of such nature shall be given in each Payment Certificate.
Hire of Plant and Machinery	7.6	Plant and Machinery, required for execution of the Works, may be issued to the Contractor, if available, on the rates of hire charges and other terms and conditions as per the departmental/ Organisation Rules, as per Schedule annexed to these conditions. Rates of such Plant & Machinery shall be got revised periodically so as to bring them at par with market rate.
Imported Store articles to be obtained from the Procuring Entity <i>(Not applicable in case of Lump Sum Contract)</i>	7.7	The Contractor shall obtain from the stores of the Engineer-in-charge, all imported store articles, which may be required for the Works or any part thereof, or in making up articles required thereof, or in connection therewith, unless he has obtained permission, in writing, from the Engineer Incharge. to obtain such stores and articles from elsewhere. The value of such stores and articles, as may be supplied to the Contractor by the Engineer In charge, will be debited to the Contractor, in his account, at the rates shown in the Schedule attached to the Contract, and if they are not entered in the Schedule, they will be debited at cost price, which for the purposes of this Contract, shall include the cost of carriage and all other expenses, whatsoever, which shall have been incurred in obtaining delivery of the same at the stores aforesaid plus storage charges.
Materials Supplied by the Contractor	7.8	The Contractor shall, at his own expense, provide all materials conforming to the specifications from the sources approved by the Engineer-In-Charge, required for the Works other than those, which are stipulated, to be supplied by the Procuring Entity. Samples for all such materials shall be collected by the Contractor and tested in the presence of representative of the Engineer-in-Charge, at the field laboratory established by the Contractor at the site. Tests which cannot be carried out at the field laboratory, shall be got tested at an NABL accredited laboratory, or any ISI approved laboratory or a Government /Departmental laboratory approved by the Engineer-in-Charge. Only materials so approved shall be used in the works and any change of materials shall be similarly got approved again. Works constructed/executed with unapproved materials shall be summarily rejected without any further investigation or testing. The Contractor shall not be eligible for any claim or compensation either arising out of any delay in the work or due to any corrective measures required to be taken on account of and as a result of testing of materials. The Engineer-in-Charge shall have full powers to require

		<p>the removal from the premises, of all materials which in his opinion are not in accordance with the Specifications and in case of default the Engineer-in-Charge shall be at liberty to employ at the expense of the Contractor, other persons to remove the same without being answerable or accountable for any loss for damage that may happen or arise to such Materials. The Engineer-in-Charge shall also have full powers to require other proper Materials to be substituted thereof and in case of default the Engineer-in-charge may cause the same to be supplied from other suitable sources and all Costs which may be incurred for such removal and substitution shall be borne by the Contractor.</p>
Testing	7.9.1	<p>This Sub-Clause shall apply to all tests specified in the Contract, other than the Tests after Completion (if any). Except as otherwise specified in the Contract, the Contractor shall provide a field laboratory with all apparatus, assistance, documents and other information, electricity, equipment, fuel, consumables, instruments, labour, materials, and suitably qualified and experienced staff, as are necessary to carry out the specified tests efficiently. The Contractor shall agree, with the Engineer-in-charge, the time and place for the specified testing of any Plant, Materials and other parts of the Works.</p> <p>The Engineer-in-charge may, under Sub-Clause 9.2.1 [Deviations/ Variations, Extent and Pricing], vary the location or details of specified tests, or instruct the Contractor to carry out additional tests. If these varied or additional tests show that the tested Plant, Materials or works or workmanship is not in accordance with the Contract, the Cost of carrying out this variation shall be borne by the Contractor, notwithstanding other provisions of the Contract.</p> <p>The Engineer-in-charge shall give the Contractor not less than 24 hours' notice of the Engineer-in-charge's intention to attend the tests. If the Engineer-in-charge does not attend at the time and place agreed, he may designate a qualified and authorised person to attend the testing, if not, the Contractor may approach the Procuring Entity for deputing an Engineer / any other experienced person to witness the tests. In no case shall the tests be conducted without an Engineer/competent person representing the Procuring Entity.</p>
	7.9.2	<p>If the Contractor suffers delay and/or incurs Cost from complying with these instructions or as a result of a delay for which the Procuring Entity is responsible, the Contractor shall give notice to the Engineer-in-charge and shall be entitled subject to Sub-Clause 21.2 [Contractor's Claims] to:</p> <ul style="list-style-type: none"> i an extension of time for any such delay, if completion is or will be delayed, under Sub-Clause 8.6

		<p>[Extension of Time for Completion], and</p> <p>ii payment of any such Cost, which shall be included in the Contract Price.</p> <p>After receiving this notice, the Engineer-in-charge shall proceed in accordance with Sub-Clause 3.5 [Determinations] to agree or determine these matters</p> <p>The Contractor shall promptly forward to the Engineer-in-charge, duly certified reports of the tests. When the specified tests have been passed, the Engineer-in-charge shall endorse the Contractor's test certificate.</p>
Cost of Samples	7.10	All samples shall be supplied by the Contractor at his own Cost if the supply thereof is clearly intended by or provided for in the Contract.
Cost of Tests	7.11	<p>The Cost of conducting any test shall be borne by the Contractor if such test is:</p> <p>i. clearly intended by or provided for in the Contract, or</p> <p>ii. particularised in the Contract (In case only of a test under load or of a test to ascertain whether the design of any finished or partially finished work is appropriate for the purposes for which it was intended to fulfil) in sufficient detail to enable the Contractor to price or allow for the same in his Bid.</p>
Cost of Tests not provided for	7.12	<p>If any test required by the Engineer-in-charge which is:</p> <p>i not so intended by or provided for in the Contract or codes;</p> <p>ii (in the cases above mentioned) not so particularized, or</p> <p>iii (though so intended or provided for), if required by the Engineer-in-charge to be carried out at any place other than the Site or the place of manufacture, fabrication or preparation of the Materials or Plant, on test shows the Materials, Plant or work or workmanship not to be in accordance with the provisions of the Contract/ specifications to the satisfaction of the Engineer-in-charge, then the Cost of such test shall be borne by the Contractor, but in any other case Department/ Organisation will bear the Cost.</p>
Rejection	7.13	<p>If, as a result of an examination, inspection, measurement or testing, any Plant, Materials, works or workmanship is found to be defective or otherwise not in accordance with the Contract, the Engineer-in-charge may reject the works, Plant, Materials or workmanship by giving notice to the Contractor, with reasons. The Contractor shall then promptly make good the defect and ensure that the reconstructed/ reproduced/ replaced item complies with the Contract.</p> <p>If the Engineer-in-charge requires this Plant, Materials, works, or workmanship to be retested, the tests shall be repeated under the same terms and conditions. If the</p>

		rejection and retesting cause the Procuring Entity to incur additional Costs, the Contractor shall subject to Sub-Clause 2.5 [Procuring Entity's Claims] pay these Costs to the Procuring Entity.
Remedial Work	7.14	<p>Notwithstanding any previous test or certification, the Engineer-in-charge may instruct the Contractor to:</p> <ol style="list-style-type: none"> i. remove from the Site and replace any works, Plant or Materials which is not in accordance with the Contract, ii. remove and re-execute any other work which is not in accordance with the Contract, and iii. execute any work which is urgently required for the safety of the Works, whether because of an accident, unforeseeable event or otherwise. <p>The Contractor shall comply with the instruction within a reasonable time, which shall be the time(if any)specified in the instruction, or immediately if urgency is specified under sub-paragraph iii.</p> <p>If the Contractor fails to comply with the instruction, the Procuring Entity shall be entitled to employ and pay other persons to carry out the work. Except to the extent that the Contractor would have been entitled to payment for the work, the Contractor shall subject to Sub-Clause 2.5 [Procuring Entity's Claims] pay to the Procuring Entity all Costs arising from this failure.</p>
Ownership of Plant and Materials	7.15	<p>Except as otherwise provided in the Contract, each item of Plant and Materials shall, to the extent consistent with the Contract, become the property of the Procuring Entity at whichever is the earlier of the following times, free from liens and other encumbrances:</p> <ol style="list-style-type: none"> i when it is incorporated in the Works; ii when the Contractor is paid the corresponding value of the Plant and Materials under Sub-Clause 8.12 [Payment for Plant and Materials in event of Suspension].
Dismantled Material Government Property	7.16	<p>The Contractor, in course of the Works, should understand that all materials e.g. stone, bricks, steel and other materials obtainable in the Works by dismantling etc. will be considered as the property of the Procuring Entity and will be disposed off to the best advantage of the Procuring Entity, as per directions, of the Engineer-in-charge.</p>
Action where no Specifications are provided.	7.17	<p>In the case of any class of works for which there are no specifications in Bureau of Indian Standards Specifications, Indian Road Congress for road Works and Indian Building Congress for building Works or any Central Government agency, or Departmental Specifications, such works shall be carried out in accordance with the relevant International Standards under the instructions and requirements of the Engineer-</p>

		in-Charge.
Royalties	7.18	<p>The Contractor shall pay all royalties, rents and other payments for:</p> <ul style="list-style-type: none"> i natural Materials obtained from outside the Site, and ii disposal of materials from demolitions and excavations and of other surplus materials (whether natural or man-made), except to the extent that disposal areas within the Site are specified in the Contract. iii the liability, if any, on account of quarry fees, royalties, octroi and any other taxes and duties in respect of materials actually consumed on public work shall be borne by the Contractor.
8. Commencement, Delays and Suspension		
Fixing centerlines, reference points and bench marks.	8.1	<p>The basic centre lines, reference points and benchmarks will be fixed by the by the Contractor and checked/confirmed by the Engineer-in-Charge. The Contractor shall establish at his own Cost at suitable points, additional reference lines and benchmarks as may be necessary and instructed by the Engineer-in-Charge. The Contractor shall remain responsible for the sufficiency and accuracy of all the benchmarks and reference lines.</p>
Setting out of works.	8.2	<p>The Contractor shall set out the Works in relation to original points, lines and levels of reference specified in the Contract or notified by the Engineer-in-Charge. The Contractor shall be responsible for the correct positioning of all parts of the Works, and shall rectify any error in the positions, levels, dimensions or alignment of the Works.</p> <p>The Procuring Entity shall be responsible for any errors in these specified or notified items of reference, but the Contractor shall use reasonable efforts to verify their accuracy before they are used. If the Contractor suffers delay and/or incurs Cost from executing work which was necessitated by an error in these items of reference, and an experienced contractor could not reasonably have discovered such error and avoided this delay and/ or Cost, the Contractor shall give notice to the Engineer-in-Charge and shall be entitled subject to Sub-Clause 21.2 [Contractor's Claims] to:</p> <ul style="list-style-type: none"> i. an extension of time for any such delay, if completion is or will be delayed, under Sub-Clause 8.6 [Extension of Time for Completion], and ii. payment of any such Cost, which shall be included in the Contract Price. <p>After receiving this notice, the Engineer-in-Charge shall proceed in accordance with Sub-Clause 3.5 [Determinations] to agree or determine (a) whether and (if so) to what extent the error could not reasonably have been discovered, and (b) the matters described in sub-</p>

		paragraphs i and ii above related to this extent.
Commencement of Works	8.3.1	<p>Except otherwise specified in the Contract Data/Special Conditions of Contract, the Commencement Date shall be the date at which the following precedent conditions have all been fulfilled and the Engineer-in-charge's instruction recording the agreement of both Parties on such fulfilment and instructing to commence the Work is received by the Contractor:</p> <ul style="list-style-type: none"> i signature of the Contract Agreement (after submission of Performance security and Insurance by the Contractor) by both Parties, and if required, approval of the Contract by relevant authorities; ii delivery to the Contractor of reasonable evidence of the Procuring Entity's Financial arrangements; iii except if otherwise specified in the Contract Data, possession of the Site given to the Contractor together with such permission(s) under (a) of Clause 2.1 [Right of Access to the Site] as required for the commencement of the Works; <p>The Contractor shall commence the execution of the Works as soon as is reasonably practicable after the Commencement Date, and shall then proceed with the Works with due expedition and without delay. The date of commencement and stipulated completion shall be entered in the Contract Agreement.</p>
	8.3.2	<p>In case, the work cannot be started within one-fourth time of the stipulated period of completion of the Works due to reasons not within the control of the Contractor as decided by the Procuring Entity, either Party may close the Contract. In such eventuality, the Performance Security of the Contractor shall be refunded, but no payment on account of interest, loss of profit or damages etc. shall be payable at all.</p>
Time for Completion	8.4	<p>The Contractor shall complete the whole of the Works, and each Section (if any), within the Time for Completion for the Works or Section (as the case may be), including:</p> <ul style="list-style-type: none"> i achieving the passing of the Tests on Completion, and ii completing all work which is stated in the Contract as being required for the Works or Section to be considered to be completed for the purposes of taking-over under Clause 12 [Taking Over of the Works and Sections]. iii completion of as built drawings and a manual for maintenance and operations, if required. iv completion of each mile stone as per the current (original updated every month) construction program. v rectification and or reconstruction of all deficient items of work or works /items of works for which 'Non Conformance Reports' were issued.

		vi restoration of the approach roads, fencing and appurtenant works damaged during execution of the Contracted project and clearance of Site.
Construction Programme (Activity Schedule in case of Lump Sum Contract)	8.5	<p>The Contractor shall submit a detailed execution time programme on MS Project or other similar software to the Engineer-in-charge within 28 Days after receiving the notice under Sub-Clause 8.3 [Commencement of Works]. The Contractor shall also submit a revised programme whenever the previous programme is inconsistent with actual progress or with the Contractor's obligations. Each programme shall be revised every month and shall include:</p> <ul style="list-style-type: none"> i the order in which the Contractor intends to carry out the Works, including the anticipated timing of each stage of design (if any), drawings, Contractor's Documents, procurement, manufacture of Plant, delivery to Site, construction of works, erection and testing, ii each of these stages for work by each Sub-Contractor/ Nominated Sub-Contractor, iii the sequence and timing of quality and other inspections and tests specified in the Contract, and iv a supporting report which includes: <ul style="list-style-type: none"> a. a general description of the time, methods which the Contractor intends to adopt, and of the major stages, in the execution of the Works, and b. details showing the Contractor's reasonable estimate of the number of each class of Contractor's Personnel and of each type of Contractor's Equipment, required on the Site for each major stage. <p>Unless the Engineer-in-charge, within 21 Days after receiving a programme, gives notice to the Contractor stating the extent to which it does not comply with the Contract, the Contractor shall proceed in accordance with the programme, subject to his other obligations under the Contract. The Procuring Entity's Personnel shall be entitled to rely upon the programme when planning their activities.</p> <p>The Contractor shall promptly give notice to the Engineer-in-charge of specific probable future events or circumstances which may adversely affect the Works, increase the Contract Price or delay the execution of the Works. The Engineer-in-charge may require the Contractor to submit an estimate of the anticipated effect of the future event or circumstances, and/or a proposal under Sub-Clause 9.2 [Deviations/ Variations Extent and Pricing].</p> <p>If, at any time, the Engineer-in-charge gives notice to the Contractor that a programme fails (to the extent stated) to comply with the Contract or to be consistent with actual</p>

		progress and the Contractor's stated intentions, the Contractor shall submit a revised programme to the Engineer-in-charge in accordance with this Sub-Clause.
Extension of Time for Completion	8.6	<p>The Contractor shall be entitled subject to Sub-Clause 21.2 [Contractor's Claims] to an extension of the Time for Completion if and to the extent that completion for the purposes of Clause 12 [Taking Over of the Works and Sections] is or will be delayed by any of the following causes:</p> <ol style="list-style-type: none"> i. a Variation (unless an adjustment to the Time for Completion has been agreed under Clause 9 [Deviations, Variations and Adjustments] or other substantial change in the quantity/design of an item of work included in the Contract, ii. a cause of delay giving an entitlement to extension of time under a Sub-Clause of these Conditions, iii. exceptionally adverse climatic conditions, excluding the rains, high or low variations in temperatures, iv. Unforeseeable shortages in the availability of personnel or Goods caused by epidemic or Governmental actions, or v. any delay, impediment or prevention caused by or attributable to the Procuring Entity, the Procuring Entity's Personnel, or the Procuring Entity's other Contractors <p>If the Contractor considers himself to be entitled to an extension of the Time for Completion, the Contractor shall give notice to the Engineer-in-charge in accordance with Sub-Clause 21.2 [Contractor's Claims]. When determining each extension of time under Sub-Clause 3.5 [Determinations], the Engineer-in-charge shall review previous determinations and may increase, but shall not decrease, the total extension of time.</p>
Delays Caused by Authorities	8.7	<p>If the following conditions apply, namely:</p> <ol style="list-style-type: none"> i. the Contractor has diligently followed the procedures laid down by the relevant legally constituted public authorities in the Country, ii. these authorities delay or disrupt the Contractor's work, and iii. the delay or disruption was Unforeseeable, <p>Then this delay or disruption will be considered as a cause of delay under Sub-Clause 8.6 [Extension of Time for Completion].</p>
Rate of progress of works.	8.8	<p>As soon as possible after the Contract is concluded the Contractor shall submit a time and progress chart (preferably on MS Project or other similar software) for each milestone and get it approved by the Engineer-in-Charge. The chart shall be prepared in direct relation to the time stated in the Contract documents for completion of items of the work. It shall indicate the forecast of the dates of commencement and completion of various tasks</p>

		<p>or sections of the work and may be amended as necessary by agreement between the Engineer-in-Charge and Contractor within the limitations of time imposed in the Contract documents, and further to ensure good progress during the execution of the work, the Contractor shall in all cases in which the time allowed for any work, exceeds one month complete the work as per milestone.</p> <p>If, at any time:</p> <ol style="list-style-type: none"> i. actual progress is too slow to complete within the Time for Completion, and/or progress has fallen (or will fall) behind the current programme under Sub-Clause 8.5 [Construction Programme], other than as a result of a cause listed in Sub-Clause 8.6 [Extension of Time for Completion], then the Engineer-in-charge may instruct the Contractor to submit, under Sub-Clause 8.5 [Construction Programme], a revised programme and supporting report describing the revised methods which the Contractor proposes to adopt in order to expedite progress and complete within the Time for Completion. ii. Unless the Engineer-in-Charge notifies otherwise, the Contractor shall adopt these revised methods, which may require increases in the working hours and/or in the numbers of Contractor's Personnel and/or Goods, at the risk and Cost of the Contractor. If these revised methods cause the Procuring Entity to incur additional Costs, the Contractor shall subject to notice under Sub-Clause 2.5 [Procuring Entity's Claims] pay these Costs to the Procuring Entity, in addition to delay damages (if any) under Sub-Clause 8.9 below. iii. Additional Costs of revised methods including acceleration measures, instructed by the Engineer-in-charge to reduce delays resulting from causes listed under Sub-Clause 8.6 [Extension of Time for Completion] shall be paid by the Procuring Entity, without generating, however, any other additional payment benefit to the Contractor <p>If the progress of the work has fallen so much in arrears as to prevent other contractors on the work from carrying out their part of the work within the stipulated time, he will be liable for the settlement of any claim put in by any of these contractors for the expenses of keeping their labor unemployed to the extent considered reasonable by the Engineer-in-charge.</p>
<p>Compensation/ Damages for Delay (Liquidated</p>	<p>8.9</p>	<ol style="list-style-type: none"> i If the Contractor fails to maintain the required progress in terms of Sub-Clause 8.4 [Extension of Time for Completion] or to complete the Works and clear the Site on or before the original or extended

<p>Damage)</p> <p><i>(In case of Lump Sum Contract, the liquidated damages shall be linked to Stage wise completion of Works as stated in Activity Schedule and specified in SCC)</i></p>		<p>date of completion, he shall, without prejudice to any other right or remedy available under the Law to the Government/ procuring Entity on account of such breach, pay as agreed compensation the amount calculated at the rates stipulated below as the Engineer-in-charge (whose decision in writing shall be final and binding) may decide on the amount of contracted value of the Works for every time span that the progress remains below that specified in Sub-Clause 8.4 [Extension of Time for Completion] or that the Works remains incomplete. This will also apply to items or group of items for which a separate period of completion has been specified.</p> <p>ii To ensure good progress during the execution of Works, the Contractor shall be bound, in all cases in which the time allowed for any Works exceeds one month (save for special jobs or where time spans have been fixed in light of the specific construction programme), to complete 1/8th of the whole of the work before 1/4th of the whole time allowed under the contract has elapsed, 3/8th of the work before 1/2 of such time has elapsed and 3/4th of the work before 3/4 of such time has elapsed. If the Contractor fails to complete the work in accordance with this time schedule in terms of cost in money, and the delay of execution of Works is attributable to the Contractor, the Contractor shall be liable to pay compensation to the Government/ Procuring Entity at every time span as below:-</p> <table border="1" data-bbox="592 1199 1344 1896"> <tr> <td data-bbox="592 1199 641 1325">A</td> <td data-bbox="641 1199 852 1325">Time Span of full stipulated period</td> <td data-bbox="852 1199 976 1325">1/4th</td> <td data-bbox="976 1199 1101 1325">1/2th</td> <td data-bbox="1101 1199 1226 1325">3/4th</td> <td data-bbox="1226 1199 1344 1325">Full</td> </tr> <tr> <td data-bbox="592 1325 641 1461">B</td> <td data-bbox="641 1325 852 1461">Work to be completed in terms of money</td> <td data-bbox="852 1325 976 1461">1/8th (Rs)</td> <td data-bbox="976 1325 1101 1461">3/8th (Rs)</td> <td data-bbox="1101 1325 1226 1461">3/4th (Rs)</td> <td data-bbox="1226 1325 1344 1461">Full (Rs)</td> </tr> <tr> <td data-bbox="592 1461 641 1896">C</td> <td data-bbox="641 1461 852 1896">Compensation payable by the Contractor for delay attributable to Contractor at the stage of</td> <td colspan="4" data-bbox="852 1461 1344 1896"> Delay up to one fourth period of the prescribed time span – 2.5% of the work remained unexecuted. Delay exceeding one fourth of the prescribed time span but not exceeding half of the prescribed time span - 5% of the work remained unexecuted. Delay exceeding half of the prescribed time span but not exceeding three fourth of the prescribed time span - 7.5% of the work remain unexecuted. </td> </tr> </table>	A	Time Span of full stipulated period	1/4 th	1/2 th	3/4 th	Full	B	Work to be completed in terms of money	1/8 th (Rs)	3/8 th (Rs)	3/4 th (Rs)	Full (Rs)	C	Compensation payable by the Contractor for delay attributable to Contractor at the stage of	Delay up to one fourth period of the prescribed time span – 2.5% of the work remained unexecuted. Delay exceeding one fourth of the prescribed time span but not exceeding half of the prescribed time span - 5% of the work remained unexecuted. Delay exceeding half of the prescribed time span but not exceeding three fourth of the prescribed time span - 7.5% of the work remain unexecuted.			
A	Time Span of full stipulated period	1/4 th	1/2 th	3/4 th	Full															
B	Work to be completed in terms of money	1/8 th (Rs)	3/8 th (Rs)	3/4 th (Rs)	Full (Rs)															
C	Compensation payable by the Contractor for delay attributable to Contractor at the stage of	Delay up to one fourth period of the prescribed time span – 2.5% of the work remained unexecuted. Delay exceeding one fourth of the prescribed time span but not exceeding half of the prescribed time span - 5% of the work remained unexecuted. Delay exceeding half of the prescribed time span but not exceeding three fourth of the prescribed time span - 7.5% of the work remain unexecuted.																		

			<p>Delay exceeding three fourth of the prescribed time span – 10% of the work unexecuted.</p>
<p>Note-1: In case delayed period over a particular time span is split up and is jointly attributable to the Procuring Entity and the Contractor, the competent authority may reduce the compensation in proportion of delay attributable to the Procuring Entity over entire delayed period over that time span after clubbing up the split delays attributable to the Procuring Entity and this reduced compensation would be applicable over the entire delayed period without paying any escalation.</p> <p>Note-2: The compensation, levied as above, shall be recoverable from the Payment Certificate payable after the concerned time span. The total compensation for delays shall, however, not exceed 10 percent of the total value of the Works.</p> <p>iii The Contractor shall further be bound to carry out the work in accordance with the date and quantity entered in the progress statement attached to the Bid.</p> <p>iv However, if a time schedule has been submitted by the Contractor before execution of the agreement, and it is entered in agreement as submitted or as modified by the Procuring Entity or the Engineer-in-Charge, the Contractor shall complete the Works within the said time schedule. In the event of the Contractor failing to comply with the time schedule, he shall be liable to pay compensation as prescribed in foregoing paragraph of this Sub-Clause. While granting extension in time attributable to the Procuring Entity, reasons shall be recorded for each delay.</p> <p>v The amount of compensation may be adjusted or set off against any sum payable to the Contractor under this or any Contract with the Procuring Entity. In case, the Contractor does not achieve a particular milestone mentioned in Contract Data or the rescheduled milestone(s), the amount shown against that milestone shall be withheld, to be adjusted against the compensation levied at the final grant of extension of time.</p> <p>vi Withholding of this amount on failure to achieve a milestone shall be automatic without any notice to the Contractor. However, if the Contractor catches up with the progress of work on the subsequent milestone(s), the withheld amount shall be released. In case the Contractor fails to make up for the delay in subsequent milestone(s), amount mentioned</p>			

		<p>against each milestone missed subsequent also shall be withheld. However, no interest, whatsoever, shall be payable on such withheld amount.</p> <p>vii If the Contract is completed in the original time period as agreed upon in the Contract, then the Liquidated Damages so imposed for delays of intermediate milestones will be adjusted/ paid. Also, price escalation shall not be applicable if Liquidated Damages have been imposed. However, if the Contractor finishes the work as per the original time period, he shall be eligible to receive the price escalation.</p>
Suspension of Work	8.10.1	The Engineer-in-charge may for recorded reasons, at any time instruct the Contractor to suspend progress of part or all of the Works. During such suspension, the Contractor shall protect, store and secure such part or the Works against any deterioration, loss or damage. The Engineer-in-charge may also notify the cause for the suspension.
	8.10.2	<p>The Contractor shall, on receipt of the order in writing of the Engineer-in-Charge (whose decision shall be final and binding on the Contractor) suspend the progress of the Works or any part thereof for such time and in such manner as the Engineer-in-Charge may consider necessary so as not to cause any damage or injury to the work already done or endanger the safety thereof, for any of the following reasons:</p> <ol style="list-style-type: none"> i. on account of any default on the part of the Contractor; or ii. for proper execution of the Works or part thereof for reasons other than the default of the Contractor; or iii. for safety of the Works or part thereof. <p>The Contractor shall, carry out the instructions given in that behalf by the Engineer-in-Charge.</p> <p>If the suspension is ordered for reasons ii and iii above, the Contractor shall be entitled to an extension of time equal to the period of every such suspension for completion of the item or group of items of work for which a separate period of completion is specified in the Contract and of which the suspended work forms a part,</p>
Consequences of Suspension	8.11	<p>If the Contractor suffers delay and/ or incurs Cost from complying with the Engineer-in-charge's instructions under Sub-Clause 8.10 [Suspension of Work] and/ or from resuming the work, the Contractor shall give notice to the Engineer-in-charge and shall be entitled subject to Sub-Clause 21.2 [Contractor's Claims] to:</p> <ol style="list-style-type: none"> i. An extension of time for any such delay, if completion is or will be delayed, under Sub-Clause 8.6 [Extension of Time for Completion], and ii. payment of any such Cost, which shall be included in the Contract Price.

		<p>After receiving this notice, the Engineer-in-charge shall proceed in accordance with Sub-Clause 3.5 [Determinations] to agree or determine these matters.</p> <p>The Contractor shall not be entitled to an extension of time for, or to payment of the Cost incurred in making good the consequences of the Contractor's faulty design, workmanship or Materials, or of the Contractor's failure to protect, store or secure the work in accordance with Sub-Clause 8.10 [Suspension of Work].</p>
Payment for Plant and Materials in Event of Suspension	8.12	<p>The Contractor shall be entitled to payment of the value (as at the date of suspension) of Plant and/ or Materials which have not been delivered to Site, if:</p> <ol style="list-style-type: none"> i. the work on Plant or delivery of Plant and/ or Materials has been suspended for more than 28 Days, and ii. The Contractor has marked the Plant and/ or Materials as the Procuring Entity's property in accordance with the Engineer-in-charge's instructions.
Prolonged Suspension	8.13	<p>If the suspension under Sub-Clause 8.10 [Suspension Work]. has continued for more than 84 Days, the Contractor may request the Engineer-in-charge's permission to proceed. If the Engineer-in-charge does not give permission within 28 Days after being requested to do so, the Contractor may, by giving notice to the Engineer-in-charge, treat the suspension as an omission under Sub-Clause 9.2 [Deviations/ Variations Extent and Pricing] of the affected part of the Works. If the suspension affects the whole of the Works, the Contractor may give notice of termination under Sub-Clause 17.2 [Termination by Contractor].</p>
Resumption of Work	8.14	<p>After the permission or instruction to proceed is given, the Contractor and the Engineer-in-charge shall jointly examine the Works and the Plant and Materials affected by the suspension. The Contractor shall make good any deterioration or Defect in or loss of the Works or Plant or Materials, which has occurred during the suspension after receiving from the Engineer-in-charge an instruction to this effect under Sub-Clause 9.2 [Deviations/ Variations, Extent and Pricing].</p>
Work to be executed strictly as per specifications	8.15	<p>All Works under or in course of execution or executed in pursuance of the Contract shall at all times be executed strictly as per specifications of the Contract as established by regular testing at the specified frequency and be open and accessible to the quality inspection and supervision of the Engineer-in-Charge, his authorized subordinates in charge of the work and all the superior officers, officers of the Quality Control Organization, Third Party Inspection Agency, if engaged by the Procuring Entity, and the Contractor shall, at all times,</p>

		during the usual working hours and at all other times at which reasonable notice of the visit of such officers has been given to the Contractor, either himself be present to receive written orders and instructions or have a responsible agent duly accredited in writing, present for that purpose. Orders given to the Contractor's agent shall be considered to have the same force as if they had been given to the Contractor himself. All payments shall be linked to the specified quality of works and works failing on tests or not executed as per design, drawings and specifications shall not be paid unless rectified to the specified quality by the Contractor.
Action when Work executed with unsound materials, imperfect and unskilled workmanship	8.16	<p>If it shall be established through regular testing or post execution quality testing by the third party quality inspection agency to the Engineer-in-Charge or his higher authority or his authorized subordinates in charge of the Works, that any work has been executed with unsound, imperfect, or unskillful workmanship, or with Materials or articles provided by him for the execution of the work which are unsound or of a quality inferior to that contracted or otherwise not in accordance with the Contract, the Contractor shall, on demand in writing from the Engineer-in-Charge specifying the work, Materials or articles complained of, notwithstanding that the same may have been passed, certified and paid for, forthwith rectify, or remove and reconstruct the work so specified in whole or in part, as the case may require or as the case may be, remove the Materials or articles so specified and reconstruct, provide other proper and suitable Materials or articles at his own charge and Cost. In the event of the Contractor failing do so within a period specified by the Engineer-in-Charge in his demand aforesaid, then the Contractor shall be liable to pay compensation for the specified period, at the same rate as under Sub-Clause for non-completion of the work in time for this default.</p> <p>In such case the Engineer-in-Charge may not accept the item of work at the rates applicable under the Contract but may accept such items at reduced rates as the competent authority may consider reasonable during the preparation of on account bills or final bill if the item is so acceptable without detriment to the safety and utility of the item and the structure and incidental items rectified, or removed and re-executed at the risk and cost of the Contractor. Decision of the Engineer-in-Charge to be conveyed in writing in respect of the same will be final and binding on the Contractor.</p>
9. Deviations, variations and adjustments		
Right to Vary <i>(Additions and</i>	9.1	Variations may be initiated by the Engineer-in-charge at any time during the execution of the Works prior to issuing the Taking-Over Certificate for the Works, either

<p>Alterations in case of Lump Sum Contract)</p>		<p>by an instruction or by a request for the Contractor to submit a proposal. The Contractor shall execute and be bound by each Variation, unless the Contractor promptly gives notice to the Engineer-in-charge stating (with supporting particulars) that:</p> <ul style="list-style-type: none"> i. the Contractor cannot readily obtain the Goods required for the Variation, or ii. such Variation triggers a substantial change in the sequence or progress of the Works. <p>Upon receiving this notice, the Engineer-in-charge shall cancel, confirm or vary the instruction. Each Variation may include:</p> <ul style="list-style-type: none"> i. changes to the quantities of any item of work included in the Contract (however, such changes do not necessarily constitute a Variation), ii. changes to the quality and other characteristics of any item of work, iii. changes to the levels, positions and/ or dimensions of any part of the Works, iv. omission of any work unless it is to be carried out by others, v. any additional work, Plant, Materials or services necessary or incidental to the Works, including any associated Tests on Completion, boreholes and other testing and exploratory work, vi. Changes to the sequence or timing of the execution of the Works. <p>The Contractor shall not make any alteration and/ or modification of the Permanent Works, unless and until the Engineer-in-charge instructs or approves a Variation.</p>
<p>Deviations/ Variations Extent and Pricing</p>	<p>9.2.1</p>	<p>The Engineer-in-charge shall have power (i) to make alternations in, omissions from, additions to, or substitutions for the original Specifications, quantities, Drawings, designs and instructions that may be appear to him to be necessary or advisable during the progress of the Works, and (ii) to omit a part of the Works in case of non-availability of a portion of the Site or for any other reasons and the Contractor shall be bound to carry out the Works in accordance with any instructions given to him in writing signed by the Engineer-in-charge after approval from competent authority and such alterations, omissions, additions or substitutions shall form part of the Contract as if originally provided therein and any altered, additional or substituted work which the Contractor may be directed to do in the manner specified above as part of the Works, shall be carried out by the Contractor on the same conditions in all respects including price on which he agreed to do the main work except as hereafter provided.</p>

<p>(In case of Lump Sum Contract, Rates of measured up additions and alterations shall be as per applicable BSR or rates of Day Work given by the Contractor and forming part of the Contract)</p>	<p>9.2.2</p>	<p>The rates for such additional, altered or substituted works shall be determined in accordance with the following provisions:</p> <ol style="list-style-type: none"> i. If the rates for the additional, altered or substituted work are specified in the Contract for the Works, the Contractor is bound to carry out the additional, altered or substituted work at the same rates as are specified in the Contract for the Works. ii. If the rates for the additional, altered or substituted work are not specifically provided in the Contract for the Works, such rates will be derived from the rates for a similar class of work as are specified in the Contract for the Works. iii. If the rates for the additional, altered or substituted work cannot be determined in the manner specified in the sub-clauses i and ii above, then the rates for such composite work item shall be worked out on the basis of the concerned Schedule of Rates of the district/ area specified above minus/ plus the percentage which the total Bid amount bears to the estimated cost of the entire Works put to bid. Provided always that if the rate for such part or parts of the item is not in the Schedule of Rates, the rate for such part or parts will be determined by the Engineer-in-charge on the basis of the prevailing market rates when the work was done but the percentage of bid discount/ premium will not be subtracted/ added to such market rates. iv. If the rates for the additional, altered or substituted work item cannot be determined in the manner specified in sub sub-clause I to iii above then the contractor shall within 7 days of the date of receipt of order to carry out the work, inform the Engineer-in-charge of the rate which it is his intention to charge for such class of work supported by analysis of the rate(s) claimed and the Engineer-in-charge shall determine the rate/ rates on the basis of prevailing market rates and pay the contractor accordingly. However, the Engineer-in-charge, by notice in writing, will be at liberty to cancel his order to carry out such class of work and arrange to carry it out in such manner as he may consider advisable but under no circumstances, the Contractor shall suspend the work on the plea of non-settlement of rates on items falling under this sub-clause.
	<p>9.2.3</p>	<p>The quantum of additional work for each item shall not exceed 50% of the original quantity of the item given in the Contract and the total value of additional, altered, and substituted items of work shall not exceed 50% of the Accepted Contract Price. (This para is not applicable in case of Lump Sum Contract)</p>

	9.2.4	The time for completion of the Works shall in the event of any deviations resulting in additional Cost over the Contract Price being ordered be extended if requested by the Contractor in the proportion which the additional Cost of the altered, additional or substituted work, bears to the original Contract Price. Similarly, the proportionate time period for an item of work deleted shall be reduced from the total time period provided in the Contract.
Value Engineering	9.3	<p>The Contractor may, at any time, submit to the Engineer-in-charge a written proposal which (in the Contractor's opinion) will, if adopted, (i) accelerate completion, (ii) reduce the Cost to the Procuring Entity of executing, maintaining or operating the Works, (iii) improve the efficiency or value to the Procuring Entity of the completed Works, or (iv) otherwise be of benefit to the Procuring Entity</p> <p>The proposal shall be prepared at the Cost of the Contractor and shall include the items listed in Sub-Clause 9.2 [Deviations, Variations and Pricing].</p> <p>If a proposal, which is approved by the Engineer-in-charge, includes a change in the design of part of the Permanent Works, then unless otherwise agreed by both Parties:</p> <ol style="list-style-type: none"> i. the Contractor shall design this part, ii. Sub-Clause 4.1[Contractor's General Obligations] shall apply, and iii. If this change results in a reduction in the Contract value of this part, the Engineer-in-charge shall proceed in accordance with Sub-Clause 3.5 [Determinations] to agree or determine a fee, which shall be included in the Contract Price.
No compensation for alterations in or restriction of works to be carried out	9.4	If, at any time after the commencement of the Works, the Procuring Entity shall, for any reason, whatsoever, not require the whole Works, thereof, as specified in the Contract, to be carried out, the Engineer-in-charge shall give notice, in writing, of the fact to the Contractor, who shall have no claim to any payment or compensation, whatsoever, on account of any profit or advantage which he might have derived from the execution of the Works in full but which he did not derive in consequence of the full amount of the Works not having been carried out. Neither shall he have any claim for compensation by reason of alterations having been made in the original specifications, drawings and design and instructions, which shall involve any curtailment of the Works, as originally contemplated. Provided, that the contractor shall be paid the charges for the cartage only, of Materials actually brought to the Site of the Works by him for bonafide use and rendered surplus as a result of the abandonment or curtailment of the Works or any portion

		thereof, and taken them back by the Contractor, provided, however, that the Engineer-in-charge shall have, in all such cases, the option of taking over all or any such Materials at their purchase price or at local market rates whichever may be less. In the case of such stores, having been issued from Procuring Entity's Stores, charges recovered, including storage charges shall be refunded after taking into consideration any deduction for claim on account of any deterioration or damage while in the custody of the Contractor and in this respect the decision of the Engineer-in-charge shall be final.
Monthly Return of Extra Claims	9.5.1	To facilitate timely resolution of Contractor's claims due against the orders/ instructions of the Engineer-in-Charge, the Contractor shall submit every month along with the Intermediate Payment Claims, a comprehensive statement of claims raised by him for any work claimed as extra, up to the previous month and awaiting resolution by the Engineer-in-Charge and/ or Procuring Entity. Value of claims shall be based upon the rates and prices mentioned in the Contract or in the Schedule of Rates in force in the District/ Division/ Circle for the time being. The Engineer-in-Charge shall duly acknowledge it and proceed to act as per Sub-Clause 3.5 [Determinations]. He will communicate the resolution to the Contractor and also reasons for rejection to the Contractor's claims. The contractor shall be deemed to have waived all claims, not included in such return and will have no right to enforce any such claims not included, whatsoever be the circumstances. However, the Contractor shall continue performance on the Contract despite rejection of his claims by the Engineer-in-Charge. Such rejected claims may then be raised before the Dispute Resolution Board or the Arbitration Tribunal, as appropriate.
	9.5.2	The Contractor shall send to the Engineer-in-Charge once every three Months an up to date account giving complete details of all claims for additional payments to which the Contractor may consider himself entitled and of all additional work ordered by the Engineer-in-Charge after approval from competent authority which he has executed during the preceding quarter .
	9.5.3	Any operation or procedure incidental to or necessary to the execution of the Works has to be in contemplation of Bidder while submitting his Bid, whether or not, specifically indicated in the description of the item and the relevant Specifications, shall be deemed to be included in the rates quoted by the Bidder or the rate given in the said schedule of rates, as the case may be. Nothing extra shall be admissible for such operations/ procedures.

Provisional Sums	9.6	<p>Each Provisional Sum shall only be used, in whole or in part, in accordance with the Engineer-in-charge's instructions and the Contract Price shall be adjusted accordingly. The total sum paid to the Contractor shall include only such amounts, for the work, supplies or services to which the Provisional Sum relates, as the Engineer-in-charge shall have instructed. For each Provisional Sum, the Engineer-in-charge may instruct:</p> <ol style="list-style-type: none"> i. work to be executed (including Plant, Materials, labour or services to be supplied) by the Contractor and valued; and/ or ii. Plant, Materials or services to be procured by the Contractor from a Nominated Sub-Contractor as defined in Sub-Clause 5.2 [Nomination of Sub-Contractor] or otherwise; and for which there shall be included in the Contract Price: <ol style="list-style-type: none"> (a) the actual amounts paid (or due to be paid) by the Contractor, and (b) A sum for overhead charges, calculated at 10% percent of these actual amounts. <p>The amount of overheads (10%) shall be subject to tax liability as per law.</p> <p>The Contractor shall, when required by the Engineer-in-charge, produce invoices, vouchers and accounts or receipts in substantiation.</p>
Day Work	9.7	<p>For works of a minor or incidental nature, the Engineer-in-charge may instruct that a Variation shall be executed on a Day work basis. The work shall then be valued in accordance with the Day work Schedule included in the Contract, and the following procedure shall apply. If a Day work Schedule is not included in the Contract, this Sub-Clause shall not apply.</p> <p>Before ordering materials for the work, the Contractor shall submit quotations to the Engineer-in-charge. When applying for payment, the Contractor shall submit invoices, vouchers and accounts or receipts for any Materials/ Equipment/ Plant/ Temporary Works.</p> <p>Except for any items for which the Day work Schedule specifies that payment is not due, the Contractor shall deliver each day to the Engineer-in-charge accurate statements in duplicate which shall include the following details of the resources used in executing the previous day's work:</p> <ol style="list-style-type: none"> i. the names, occupations, day wages and required time period of Contractor's Personnel, ii. the identification, type and time of Contractor's Equipment and Temporary Works, and iii. The quantities and types of Plant and Materials used. <p>One copy of each statement will, if correct, or when agreed, be signed by the Engineer-in-charge and returned to the Contractor. The Contractor shall then</p>

		submit priced statements of these resources to the Engineer-in-charge, prior to their inclusion in the next Statement under Sub-Clause 15.5 [Issue of Interim Payment Certificates].
10. Price Variation		
Price Variation due to changes in the prices of labour, materials, bitumen, petroleum, cement and steel	10.1	<p>If, during the progress of the contract of value exceeding Rs. 50 lakh (accepted Contract Price minus cost of material supplied by the Procuring Entity), and where stipulated completion period is more than 3 months (both the conditions should be fulfilled), the price, of any materials/ bitumen/ diesel and petrol/ cement/ steel incorporated in the Works (not being materials to be supplied by the Procuring Entity) and/ or wages of labour increases or decreases, as compared to the price and/ or wages prevailing at the date of opening of bids or date of negotiations for the Works, the amounts payable to Contractor for the Works shall be adjusted for increase or decrease in the rates of materials (excepting those materials supplied by the Procuring Entity)/ labour/ bitumen /diesel and petrol/ cement/ steel. If negotiated rates have been accepted, prices as on the date of negotiation shall be considered for price adjustment. Similarly, if rates received on the date of opening of bids have been accepted, then prices on the date of opening of bids shall be considered for price adjustment.</p> <p>Increase or decrease in the cost of labour/ material/ diesel and petrol/ cement/ steel shall be calculated quarterly and cost of bitumen shall be calculated on monthly basis in accordance with the following formula:-</p> <p>(A) Labour</p> $V_L = 0.75 \times \frac{P_L}{100} \times R \times \frac{(I_{L1} - I_{L0})}{I_{L0}}$ <p>Where,</p> <p>V_L = Increase or decrease in the cost of Works during the quarter under consideration due to change in rates for labour.</p> <p>R = The value of the Works done in rupees during the quarter under consideration excluding the cost of materials supplied by the Procuring Entity and excluding other items as mentioned in this Sub-Clause.</p> <p>I_{L0} = The average consumer price index for industrial workers (whole-sale prices) for the quarter in which bids were opened/ negotiated (as published in Reserve Bank of India Journal/ Labour Bureau Simla, for the area).</p> <p>I_{L1} = The average consumer price index for industrial workers (whole-sale prices) for the quarter of calendar year under consideration (as published in Reserve Bank of India Journal/ Labour Bureau Simla,</p>

		<p>for the area).</p> <p>P_L = Percentage of labour components.</p> <p>Note: In case of revision of minimum wages by the Government or other competent authority, nothing extra would be payable except the price escalation permissible under this Sub-Clause.</p> <p>(B) Materials (excluding materials supplied by the Procuring Entity).</p> $V_M = 0.75 \times \frac{P_M}{100} \times R \times \frac{(L_{M1} - L_{M0})}{L_{M0}}$ <p>Where,</p> <p>V_M = Increase or decrease in the cost of Works during the quarter under consideration due to change in rates for materials.</p> <p>R = The value of the Works done in rupees during the quarter under consideration excluding the cost of materials supplied by the Procuring Entity and excluding other items as mentioned in this Sub-Clause.</p> <p>L_{M0} = The average wholesale price index (all commodities) for the quarter in which bids were opened/ negotiated (as published in Reserve Bank of India Journal/ Economic Adviser to Government of India, Ministry of Industries, for the area).</p> <p>L_{M1} = The average wholesale price index (all commodities) for the quarter under consideration (as published in Reserve Bank of India Journal/ Economic Adviser to Government of India, Ministry of Industries, for the area).</p> <p>P_M = Percentage of materials components (excluding materials supplied by the Procuring Entity).</p> <p>(C) Bitumen</p> $V_b = 0.85 \times \frac{P_b}{100} \times R \times \frac{(B_i - B_0)}{B_0}$ <p>Where,</p> <p>V_b = Increase or decrease in the cost of Works during the month under consideration due to changes in the rate for bitumen.</p> <p>R = The value of the Works done in rupees during the month under consideration excluding the cost of materials supplied by the Procuring Entity and excluding other items as mentioned in this Sub-Clause.</p> <p>B_0 = The official retail price of bitumen at the IOC depot at nearest center on the day 28 days prior to date of opening of Bids.</p> <p>B_i = The official retail price of bitumen of IOC depot at nearest center for the 15th day of the month under consideration.</p>
--	--	--

	<p>P_b = Percentage of bitumen components of the Works.]</p> <p>(D) Petroleum</p> $V_f = 0.75 \times \frac{P_f}{100} \times R \frac{(F_i - F_0)}{F_0}$ <p>Where,</p> <p>V_f = Increase or decrease in the cost of Works during the quarter under consideration due to change in rates for fuel and lubricants.</p> <p>R = The value of the Works done in rupees during the quarter under consideration excluding the cost of materials supplied by the Procuring Entity and excluding other items as mentioned in this Sub-Clause.</p> <p>F_0 = The average wholesale price index of High Speed Diesel (HSD) as published by the Economic Adviser to the Government of India, Ministry of Industry on the day of opening of bids/ negotiations.</p> <p>F_i = The average whole sale price Index of HSD for the quarter under consideration as published weekly by the Economic Adviser to the Government of India, Ministry of Industry for the quarter under consideration.</p> <p>P_f = Percentage of fuel and lubricants components excluding fuel and lubricants supplied by the Procuring Entity (Specified in the sanctioned estimate for the Works).</p> <p>R = Total Works done during the quarter as prescribed under this Sub-Clause.</p> <p>Note: For application of this Sub-Clause price of HSD is chosen to indicate fuel and lubricants components.</p> <p>(E) Cement</p> $V_C = 0.75 \times \frac{P_C}{100} \times R \frac{(L_{C1} - L_{C0})}{L_{C0}}$ <p>Where,</p> <p>V_C = Increase or decrease in the cost of Works during the quarter under consideration due to change in the rates of cement.</p> <p>R = The value of the Works done in rupees during the quarter under consideration excluding the cost of cement supplied by the Procuring Entity and excluding other items as mentioned in this Sub-Clause.</p> <p>L_{C0} = The average wholesale price index for the quarter in which bids were opened/ negotiated (as published by the Economic Adviser to the Government of India, Ministry of Industries).</p> <p>L_{C1} = The average whole sale price Index for the quarter under consideration (as published by the Economic</p>
--	--

		<p>Adviser to Government of India, Ministry of Industries).</p> <p>P_C = Percentage of cement components (excluding cement supplied by the Procuring Entity).</p> <p>(F) Steel</p> $V_S = 0.75 \times \frac{P_S}{100} \times R \frac{(L_{S1} - L_{S0})}{L_{S0}}$ <p>Where,</p> <p>V_S = Increase or decrease in the cost of Works during the quarter under consideration due to change in the rates of steel.</p> <p>R = The value of the Works done in rupees during the quarter under consideration excluding the cost of steel supplied by the Procuring Entity and excluding other items as mentioned in this Sub-Clause.</p> <p>L_{S0} = The average wholesale price index for the quarter in which bids were opened/ negotiated (as published by the Economic Adviser to the Government of India, Ministry of Industries).</p> <p>L_{S1} = The average wholesale price Index for the quarter under consideration (as published by the Economic Adviser to Government of India, Ministry of Industries).</p> <p>P_S = Percentage of steel components (excluding steel supplied by the Procuring Entity).</p>
<p>Price Variation in installation of elevators, supply/installation of Centrally Air Conditioning and Central Evaporating Cooling Works.</p>	<p>10.2</p>	<p>In all cases of contracts for installation of elevators, supply/ installation of Central Air Conditioning and Central Evaporating Cooling Works, the price quoted shall be based on the Indian Electrical and Electronics Manufacturers Association (IEEMA) price variation Sub-Clause based on the cost of raw materials/ components and labour cost as on the date of quotation/ bid, and the same is deemed to be related to wholesale price index number of metal products and All India Average consumer price index number of industrial workers as specified below. In case of any variation in these index numbers, the prices shall be subject to adjustment up or down in accordance with following formula:</p> $P = \frac{P_0}{100} \left[15 + 55 \frac{MP}{MP_0} + 15 \frac{MP}{W_0} + 15 \frac{W_0(D)}{W_0} \right]$ <p>Where,</p> <p>P = Price payable as adjusted in accordance with the above price variation formula.</p> <p>P_0 = Price quoted/ confirmed.</p> <p>MP_0 = Wholesale Price Index Number for Metal Products</p>

		<p>as published by the office of the Economic Adviser, Ministry of Industry, Government of India, in their weekly bulletin, Revised Index Number of Wholesale Prices (Base: 1981- 82 = 100) for the week ending first Saturday of the relevant calendar month. The relevant month shall be that in which price was offered or negotiated whichever is later.</p> <p>W_0 = All India Average Consumer Price Index Number for Industrial workers (Base : 1982 = 100), as published by Labour Bureau, Ministry of Labour, Government of India, for relevant calendar month. The relevant month shall be that in which price was offered or negotiated whichever is later.</p> <p>The above index number MP_0 & W_0 are those published by IEEMA as prevailing on the first working day of the calendar month FOUR months prior to the date of bidding.</p> <p>MP = Wholesale Price Index Number for Metal Products as published by the office of the Economic Adviser, Ministry of Industry, Government of India, in their weekly bulletin Revised Index Number of Wholesale Prices (Base: 1981-82 = 100). The applicable wholesale price Index Number for Metal Products as prevailing on 1st Saturday of the month covering the date FOUR months prior to .the date of delivery and would be as published by IEEMA.</p> <p>$W_0(D)$ = All India Average Consumer Price Index Number for Industrial Workers prevailing for the month covering the date FOUR months prior to the date of delivery of manufactured material and would be as published by IEEMA.</p> <p>$W_0(1)$ = All India Average Consumer Price Index Number for Industrial Workers (Base : 1982 = 100) as published by Labour Bureau, Ministry of Labour, Government of India. The applicable All India Consumer Price Index Number of Industrial Workers prevailing for the FOUR months prior to the date of completion of installation/ progress parts of installation and would be as published by IEEMA. The date of delivery shall be the date on which the manufactured material is actually supplied at Site. The date of completion of installation (or progress part of installation) shall be the date on which the Works is notified as being completed and is available for inspection/ duly tested. In the absence of such notification, the date of completion is not intimated, such completion shall be considered by the Engineer Incharge which shall be final.</p> <p>Note-1 The Wholesale Price Index Number for Metal Products is published weekly by the office of the Economic Adviser, but if there are any changes, the same</p>
--	--	--

		<p>are incorporated in the issue appearing in the following week. For the purpose of this Price Variation Sub-Clause, the final index figures shall apply.</p> <p>Note-2 The sole purpose of the above stipulation is to arrive at the entire Contract under the various situations. The above stipulation does not indicate any intentions to sell materials under this Contract as movables.</p> <p>Note-3 The indices MP & Wo are regularly published by IEEMA in monthly basic price circulars based on information bulletins from the authorities mentioned. These will be used for determining price variation and only IEEMA Circulars will be shown as evidence, if required.</p>
General Conditions for admissibility of Price Variation	10.3	The General Conditions for admissibility of Price Variation are given in Appendix A to these General Conditions.
11. Tests on completion		
Contractor's obligations	11.1	<p>The Contractor shall carry out the Tests on Completion in accordance with the BIS/ IRC and other standard codes and Sub-Clause 7.9 [Testing], after providing the documents in accordance with the requirements for tests on completion.</p> <p>The Contractor shall give to the Engineer-in-charge not less than 15 Days' notice of the date after which the Contractor will be ready to carry out each of the Tests on Completion. Unless otherwise agreed, Tests on Completion shall be carried out within 7 Days after this date, on such day or Days as the Engineer-in-charge shall instruct.</p> <p>In considering the results of the Tests on Completion, the Engineer-in-charge shall make allowances for the effect of any use of the Works by the Procuring Entity on the performance or other characteristics of the Works. As soon as the Works, or a Section, have passed any Tests on Completion, the Contractor shall submit a certificate of the results of these Tests to the Engineer-in-charge.</p>
Delayed Tests	11.2	<p>If the Tests on Completion are being unduly delayed by the Engineer-in-charge, Sub-Clause 7.9.2 of 7.9 [Testing] shall be applicable.</p> <p>If the Tests on Completion are being unduly delayed by the Contractor, the Engineer-in-charge may by notice require the Contractor to carry out the Tests within 21 Days after receiving the notice. The Contractor shall carry out the Tests on such day or Days within that period as the Contractor may fix and of which he shall give notice to the Engineer-in-charge.</p> <p>If the Contractor fails to carry out the Tests on Completion within the period of 21 Days, the Procuring Entity's/ Engineer-in-Charge's Personnel may proceed</p>

		with the Tests at the field laboratory or at an outsourced laboratory at the risk and cost of the Contractor. The Tests on Completion shall then be deemed to have been carried out in the presence of the Contractor and the results of the Tests shall be accepted as accurate and binding on the Contractor.
Retesting	11.3	If the Works, or a Section, fails to pass the Tests on Completion, Sub-Clauses 7.13 [Rejection] and 11.4 [Failure to Pass Tests on Completion] shall apply, and the Engineer-In-Charge or the Contractor may require the failed Tests, and Tests on Completion on any related work, to be repeated under the same terms and conditions.
Failure to Pass Tests on Completion	11.4	<p>If the Works, or a Section, fails to pass the Tests on Completion repeated under Sub-Clause 11.3 [Retesting], the Engineer-in-Charge shall be entitled to:</p> <ol style="list-style-type: none"> i. Order further repetition of Tests on Completion; ii. If failure deprives the Procuring Entity of substantially the whole benefit of the Works or Section, reject the Works or Section (as the case may be), in which event the Procuring Entity shall have the same remedies as provided in Sub-paragraph (c) of Sub-Clause 13.6 [Failure to Remedy Defect]; or iii. Issue a Taking-Over Certificate, if the Procuring Entity so requires. <p>In the event of Sub-para iii, the Contractor shall proceed in accordance with all other obligations under the Contract, and the Contract Price shall be reduced by such amount as shall be appropriate to cover the reduced value to the Procuring Entity as a result of this failure. Unless the relevant reduction for this failure is stated (or its method of calculation is defined) in the Contract, the Procuring Entity may require the reduction to be (i) agreed by the Contractor (in full satisfaction of this failure only) and paid before this Taking-Over certificate is issued, or (ii) determined and paid under Sub-Clause 3.5 [Determinations].</p>
12. Taking over of the Works and Sections by Procuring Entity		
Taking over of works.	12.1	<p>Except as stated in Sub-Clause 11.4 [Failure to Pass Tests on Completion], the Works shall be taken over by the Procuring Entity when (a) the Works have been completed in accordance with the Contract, including the matters described in Sub-Clause 8.4 [Time for Completion] and except as allowed in sub-paragraph i. below, and (b) a Taking-Over Certificate for the Works has been issued, or is deemed to have been issued in accordance with this Sub-Clause.</p> <p>The Contractor may apply by notice to the Engineer-in-charge for a Taking-Over Certificate not earlier than 14 Days before the Works will, in the Contractor's opinion, be</p>

		<p>complete and ready for taking over. If the Works are divided into Sections, the Contractor may similarly apply for a Taking-Over Certificate for each Section.</p> <p>The Engineer-in-charge shall, within 28 Days after receiving the Contractor's application:</p> <ol style="list-style-type: none"> i. issue the Taking-Over Certificate to the Contractor, stating the date on which the Works or Section was completed in accordance with the Contract, except for any minor outstanding work and Defects which will not substantially affect the use of the Works or Section for their intended purpose (either until or whilst this work is completed and these Defects are remedied); or ii. reject the application, giving reasons and specifying the work required to be done by the Contractor to enable the Taking-Over Certificate to be issued. The Contractor shall then complete this work before issuing a further notice under this Sub-Clause. <p>If the Engineer-in-charge fails either to issue the Taking-Over Certificate or to reject the Contractor's application within the period of 28 Days, and if the Works or Section (as the case may be) are substantially in accordance with the Contract, the Taking-Over Certificate shall be deemed to have been issued on the last day of that period.</p>
<p>Taking over of Parts of the Works</p>	<p>12.2</p>	<p>The Engineer-in-charge may, at the sole discretion of the Procuring Entity, issue a Taking-Over Certificate for any part of the Permanent Works.</p> <p>The Procuring Entity shall not use any part of the Works (other than as a temporary measure which is either specified in the Contract or agreed by both Parties) unless and until the Engineer-in-charge has issued a Taking-Over Certificate for this part. However, if the Procuring Entity does use any part of the Works before the Taking-Over Certificate is issued:</p> <ol style="list-style-type: none"> i. the part which is used shall be deemed to have been taken over as from the date on which it is used, ii. the Contractor shall cease to be liable for the care of such part as from this date, when responsibility shall pass to the Procuring Entity, and iii. if requested by the Contractor, the Engineer-in-charge shall issue a Taking-Over Certificate for this part. <p>After the Engineer-in-charge has issued a Taking-Over Certificate for a part of the Works, the Contractor shall be given the earliest opportunity to take such steps as may be necessary to carry out any outstanding Tests on Completion. The Contractor shall carry out these Tests on Completion as soon as practicable before the expiry date of the relevant Defects Notification Period.</p> <p>If the Contractor incurs Cost as a result of the Procuring</p>

		<p>Entity taking over and/ or using a part of the Works, other than such use as is specified in the Contract or agreed by the Contractor, the Contractor shall:</p> <p>(a) give notice to the Engineer-in-charge, and (b) be entitled subject to Sub-Clause 21.2 [Contractor’s Claims] to payment of any such Cost, which shall be included in the Contract Price. After receiving this notice, the Engineer-in-charge shall proceed in accordance with Sub-Clause 3.5 [Determinations] to agree or determine this Cost.</p> <p>If a Taking-Over Certificate has been issued for a part of the Works (other than a Section), the delay damages thereafter for completion of the remainder of the Works shall be reduced. Similarly, the delay damages for the remainder of the Section (if any) in which this part is included shall also be reduced. For any period of delay after the date stated in this Taking-Over Certificate, the proportional reduction in these delay damages shall be calculated as the proportion which the value of the part so certified bears to the value of the Works or Section (as the case may be) as a whole. The Engineer-in-charge shall proceed in accordance with Sub-Clause 3.5 [Determinations] to agree or determine these proportions. The provisions of this paragraph shall only apply to the rate of delay damages under Sub-Clause 8.9 [Compensation/ Damages for Delay], and shall not affect the maximum amount of these damages.</p>
<p>Taking over if Tests on Completion suffer Interference</p>	<p>12.3</p>	<p>If the Contractor is prevented, for more than 14 days, from carrying out the Tests on Completion by a cause for which the Procuring Entity is responsible, the Procuring Entity shall be deemed to have taken over the Works or Section (as the case may be) on the date when the Tests on Completion would otherwise have been completed.</p> <p>The Engineer-in-charge shall then issue a Taking-Over Certificate accordingly, and the Contractor shall carry out the Tests on Completion as soon as practicable, before the expiry date of the Defects Notification Period. The Engineer-in-charge shall require the Tests on Completion to be carried out by giving 14 days’ notice and in accordance with the relevant provisions of the Contract.</p> <p>If the Contractor suffers delay and/ or incurs Cost as a result of this delay in carrying out the Tests on Completion, the Contractor shall give notice to the Engineer-in-Charge and shall be entitled subject to Sub-Clause 21.2 [Contractor’s Claims] to:</p> <ol style="list-style-type: none"> i. an extension of time for any such delay, if completion is or will be delayed, under Sub-Clause 8.6 [Extension of time for Completion], and ii. payment of any such Cost, which shall be included in the Contract Price. <p>After receiving this notice, the Engineer-in-Charge shall</p>

		proceed in accordance with Sub-Clause 3.5 [Determinations] to agree or determine these matters.
Surfaces Requiring Reinstatement	12.4	Except as otherwise states in a Taking Over Certificate, a Certificate for a Section or part of the Works shall not be deemed to certify completion of any ground or other surfaces requiring reinstatement.
13. Defect Liability		
Defect Liability Period	13.1	It is the period, as specified in the Contract data, after certified total completion or after a suspension (short or prolonged) or termination of the Works by the Engineer-in-Charge or the Contractor and handing over of the Works (including Sections or parts handed over earlier) to the Engineer-in-Charge, during which the Contractor is responsible for remedying/ repairing, restoring to the original condition any apparent, virtual or observed defects, deficiencies in the Works, or its performance. The Contractor shall have to repair & restore the defect/ deficiency after a notice issued by the Engineer-in-Charge, who will be free to get it remedied at the risk and cost of the Contractor besides other action being taken as per the Contract, if the Contractor does not get it remedied within the period specified in such notice. The attendances to normal wear and tear due to use by the Procuring Entity/ occupier, in respect of sections or parts taken over for the convenience of the Procuring Entity, shall not be treated as defect.
Completion of Outstanding Work and Remedying Defects.	13.2	In order that the Works and Contractor's Documents, and each Section, shall be in the condition required by the Contract (fair wear and tear excepted) by the expiry date of the relevant Defects Notification Period or as soon as practicable thereafter, the Contractor shall: <ul style="list-style-type: none"> i. complete any work which is outstanding on the date stated in a Taking-Over Certificate, within such reasonable time as is instructed by the Engineer-in-charge, and ii. Execute all work required to remedy Defects or damage, as may be notified by (or on behalf of) the Procuring Entity on or before the expiry date of the Defects Notification Period for the Works. <p>If a Defect appears or damage occurs, the Contractor shall be notified accordingly, by (or on behalf of) the Procuring Entity. The Contractor is required to repair, rectify, the defects, restore the damages at his own cost with in the period indicated in the notice by the Procuring Entity. If the Contractors fails to do so, action as per Sub-Clause 13.3 shall be taken.</p>
Cost of Remedying Defects	13.3	All work referred to in Sub-Clause 13.2 above [Completion of Outstanding Work and Remedying Defects] shall be executed at the risk and cost of the Contractor, if and to the extent that the work is attributable to:

		<p>i. any design for which the Contractor is responsible, ii. Plant, Materials or workmanship not being in accordance with the Contract, or iii. Failure by the Contractor to comply with any other obligation.</p> <p>The cost to be debited shall be arrived at as under: (a.) Cost of remedial work (including taxes) as paid to other agency or debited to the contractor if the remedial action is taken up by the department/ organisation, plus (b.) A compensation of 15% , less (c.) Credit the cost of materials, hire charges of Contractor's plant and machinery if used in the remedial work.</p> <p>If and to the extent that such work is attributable to any other cause, the Contractor shall be notified promptly by (or on behalf of) the Procuring Entity and Sub-Clause 9 [Deviations, Variations and Adjustments] shall apply.</p>
Extension of Defects Notification Period	13.4	<p>The Procuring Entity shall be entitled subject to Sub-Clause 2.5 [Procuring Entity's Claims] to an extension of the Defects Notification Period for the Works or a Section if and to the extent that the Works, Section or a major item of work (as the case may be, and after taking over) cannot be used for the purposes for which they are intended by reason of a Defect, deficiency or by reason of damage attributable to the Contractor. However, a Defects Notification Period shall not be extended by more than two years.</p> <p>If delivery and/ or erection of Plant and/ or Materials was suspended under Sub-Clause 8.10 [Suspension of Work] or Sub-Clause 17.1 [Contractor's Entitlement to Suspend Work], the Contractor's obligations under this Sub-Clause shall not apply to any Defects or damage occurring more than two years after the Defects Notification Period for the Plant and/ or Materials would otherwise have expired.</p>
Contractor liable for Damages done and for Imperfections	13.5	<p>If the Contractor or his personnel shall break, deface, injure or destroy any part of a building or any structure in which they may be working, or any building, road, fence, enclosure, water pipe, power/ telecom cables, drains, electric or telephone post or wires, trees, etc. or cultivated ground contiguous to the Site where the Works or any part of it is being executed, or if any damage shall happen to the work while in progress, from any cause whatever or if any defect, shrinkage or other faults or imperfection appear in the work within Defect Liability Period after a certificate final or otherwise of its completion shall have been given by the Engineer-in-Charge as aforesaid arising out of Defect or improper Materials, procedures or workmanship the Contractor shall upon receipt of a notice in writing on that behalf make the same good at his own expense or in default the Engineer-in-Charge cause the</p>

		same to be made good by employing other workman/ agency and deduct the expense from any sums that may be due or at any time thereafter may become due to the Contractor, or from his Performance Security or the proceeds of sale thereof or a sufficient portion thereof.
Failure to remedy the defect	13.6	<p>If the Contractor fails to remedy any Defect, deficiency or damage within a reasonable time, a date may be fixed by (or on behalf of) the Procuring Entity, on or by which the Defect, deficiency or damage is to be remedied. The Contractor shall be given reasonable notice of this date.</p> <p>If the Contractor fails to remedy the Defect or damage by this notified date and this remedial work was to be executed at the cost of the Contractor under Sub-Clause 13.3 [Cost of Remedying Defects], the Procuring Entity may (at his option):</p> <ol style="list-style-type: none"> i. carry out the work himself or by others, in a reasonable manner and at the Contractor's cost, but the Contractor shall have no responsibility for this work; and the Contractor shall subject to Sub-Clause 2.5 [Procuring Entity's Claims] pay to the Procuring Entity the costs reasonably incurred by the Procuring Entity in remedying the Defect or damage; ii. require the Engineer-in-charge to agree or determine a reasonable reduction in the Contract Price in accordance with Sub-Clause 3.5 [Determinations]; or iii. If the Defect or damage deprives the Procuring Entity of substantially the whole benefit of the Works or any major part of the Works, terminate the Contract as a whole, or in respect of such major part which cannot be put to the intended use. Without prejudice to any other rights, under the Contract or otherwise, the Procuring Entity shall then be entitled to recover all sums paid for the Works or for such part (as the case may be), plus financing Costs and the Cost of dismantling the same, clearing the Site and returning Plant and Materials to the Contractor.
Removal of Defective Work	13.7	<p>If the Defect or damage cannot be remedied expeditiously on the Site and the Procuring Entity gives consent, the Contractor may remove from the Site for the purposes of repair such items of Plant as are Defective or damaged. This consent may require the Contractor to increase the amount of the Performance Security by the full replacement Cost of these items, or to provide other appropriate security.</p>
Further Tests	13.8	<p>If the work of remedying of any Defect or damage may affect the performance of the Works, the Engineer-in-charge may require the repetition of any of the tests described in the Contract. The requirement shall be made by notice within 28 Days after the Defect or damage is</p>

		remedied. These tests shall be carried out in accordance with the terms applicable to the previous tests, except that they shall be carried out at the risk and cost of the Party liable, under Sub-Clause 13.3 [Cost of Remedying Defects], for the cost of the remedial work.
Contractor / Third Party Quality Inspection Agency to Search for the Cause of the Defect.	13.9	The Contractor or third party quality inspection agency shall, if required by the Engineer-in-charge, search for the cause of any Defect, under the direction of the Engineer-in-charge. Unless the Defect is to be remedied at the cost of the Contractor under Sub-Clause 13.3 [Cost of Remedying Defects], the cost of the search shall be agreed or determined by the Engineer-in-charge in accordance with Sub-Clause 3.5 [Determinations] and shall be included in the Contract Price or of the third party quality inspection agency.
Performance Certificate	13.10	Performance of the Contractor's obligations shall not be considered to have been completed until the Engineer-in-charge has issued the Performance Certificate to the Contractor, stating the date on which the Contractor completed his obligations under the Contract. The Engineer-in-charge shall issue the Performance Certificate within 28 Days after the latest of the expiry dates of the Defects Liability Periods, or as soon thereafter as the Contractor has supplied all the Contractor's Documents and completed and tested all the Works, including remedying any Defects. A copy of the Performance Certificate shall be issued to the Procuring Entity. Only the Performance Certificate shall be deemed to constitute acceptance of the Works.
Substantial Completion of Parts	13.11	If any part of the Permanent Works has been substantially completed and has satisfactorily passed any Test on Completion prescribed by the Contract, the Engineer-in-charge may issue a Taking-Over Certificate in respect of that part of the Permanent Works before completion of Works and upon the issue of such Certificate, the Contractor shall be deemed to have undertaken to complete with due expedition any outstanding work in that part of the Permanent Works during Defect Liability Period.
Unfulfilled Obligations	13.12	After the Performance Certificate has been issued, each Party shall remain liable for the fulfillment of any obligation which remains unperformed at that time. For the purposes of determining the nature and extent of unperformed obligations, the Contract shall be deemed to remain in force.
Right to Access	13.13	Until the Performance Certificate has been issued, the Contractor shall have such right of access to the Works as is reasonably required in order to comply with this Sub-

		Clause, except as may be inconsistent with the Procuring Entity's reasonable security restrictions.
Clearance of Site	13.14	<p>Upon receiving the Performance Certificate, the Contractor shall remove any remaining Contractor's Equipment, surplus material, wreckage, rubbish and Temporary Works from the Site.</p> <p>If all these items have not been removed within 28 days after receipt by the Contractor of the Performance Certificate, the Procuring Entity may sell or otherwise dispose of any remaining items. The Procuring Entity shall be entitled to be paid the costs incurred in connection with, or attributable to, such sale or disposal and restoring the Site.</p> <p>Any balance of the moneys from the sale shall be paid to the Contractor. If these moneys are less than the Procuring Entity's costs, the Contractor shall pay the outstanding balance to the Procuring Entity.</p>
14. Measurement and Evaluation. (In case of Lump Sum Contract measurement of only additions and alterations shall be taken)		
Measurement of Work Done	14.1	<p>Whenever the Engineer-in-charge requires any part of the Works to be measured/ re-measured, reasonable notice shall be given to the Contractor's Representative, who shall:</p> <ol style="list-style-type: none"> i. promptly either attend or send another qualified representative to assist the Engineer-in-charge in taking/ verifying the measurement, and ii. Supply any particulars requested by the Engineer-in-charge for his satisfaction of the measurements. <p>If the Contractor fails to attend or send a representative, the measurement made by (or on behalf) of the Engineer-in-charge shall be accepted as accurate.</p>
Method of measurement.	14.2.1	<p>The measurements (as per IS 1200) of the executed and acceptable work shall be recorded once in a month by the representative of the Engineer-in-Charge and the Contractor or his representative jointly and shall be signed by the Contractor in acceptance. The Engineer-in-Charge shall, except as otherwise provided, shall check, ascertain and determine measurement and the value of the work done in accordance with the Contract. The Procuring Entity reserves to itself the right to prescribe a scale of check measurements of work, in general, or a specific scale for specific works or by other special orders (about which the decision of the Procuring Entity shall be final). Checking of measurement by a superior officer shall supersede the measurements taken by the subordinate officers and the former will become the basis of the payment. Any excess payments detected, as a result of such check measurement or otherwise at any stage up to the date of completion and the Defect Liability Period specified</p>

		<p>elsewhere in this Contract, shall be recoverable from the Contractor as any other dues payable to the Procuring Entity.</p> <p>The Contractor shall, without extra charge, provided all necessary assistance with labour and equipment necessary for measurements and recording levels.</p> <p>If the Contractor objects to any of the measurements recorded, a note shall be made to that effect with reason and signed by both the parties.</p>
	14.2.2	<p>All measurement of all items having financial value shall be recorded in Measurement Book or MS Excel file and printed out in two copies. The original shall be treated as the Measurement book. Such files in original shall be mailed to the Engineer-in-Charge and shall be saved with a dedicated password. Other data like initial field levels or survey field books or findings of the geo tech investigations shall be similarly recorded and protected so that a complete record is obtained of all works performed under the Contract.</p>
	14.2.3	<p>If for any reason the Contractor or his authorized representative is not available and the work of recording measurements is suspended by the Engineer-in-charge or his representative, the Engineer-in-Charge and the Department/ Organisation shall not entertain any claim from Contractor for any loss or damages on this account. If the Contractor or his authorized representative does not remain present at the time of such measurements after the Contractor or his authorized representative has been given a notice in writing three (3) Days in advance or fails to countersign or to record objection within seven days from the date of the measurement, then such measurements recorded in his absence by the Engineer-in-charge or his representative shall be deemed to have been accepted by the Contractor.</p> <p>Except where any general or detailed description of the work expressly shows to the contrary, measurements shall be taken of the net actual quantities in accordance with the procedure set forth in the Bill of Quantities and IS 1200 notwithstanding any general or local practice.</p> <p>The Contractor shall give not less than seven Day's notice to the Engineer-in-Charge or his authorized representative in charge of the Works before covering up or otherwise placing beyond the reach of measurement any work in order that the same may be measured and correct dimension thereof be taken before the same is covered up or placed beyond the reach of measurements and shall not cover and place beyond reach of measurement any work without consent in writing of the Engineer-in-Charge or his authorized representative in charge of the Works who shall within the aforesaid period of seven Days inspect the work,</p>

		<p>and if any work shall be covered up or placed beyond the reach of measurements without such notice having been given or the Engineer-in-charge's consent being obtained in writing, the same shall be uncovered at the Contractor's expense, for the due measurement or in default thereof no payment or allowance shall be made for such works or the materials with which the same was executed. The covering shall then be restored by the Contractor at his cost.</p> <p>Engineer-in-Charge or his authorized representative may cause either themselves or through another officer of the Department/ Organisation to check the measurements recorded jointly or otherwise as aforesaid and all provisions stipulated herein above shall be applicable to such checking of measurements or levels.</p> <p>It is also a term of this Contract that recording of measurements of any item of work in the measurement sheets/ Measurement book and/ or its payment in the interim, on account or final bill shall not be considered as conclusive evidence as to the sufficiency of any work or material to which it relates, nor shall it relieve the Contractor from liabilities from any other measurement, Defects noticed till completion of the Defects liability period.</p>
Omissions	14.3	<p>Whenever the omission of any work forms part (or all) of a Variation, the value of which has not been agreed, if:</p> <ol style="list-style-type: none"> i. the Contractor will incur (or has incurred) Cost which, if the work had not been omitted, would have been deemed to be covered by a sum forming part of the Accepted Contract Amount; ii. the omission of the work will result (or has resulted) in this sum not forming part of the Contract Price; and iii. this Cost is not deemed to be included in the evaluation of any substituted work; then the Contractor shall give notice to the Engineer-in-charge accordingly, with supporting particulars. Upon receiving this notice, the Engineer-in-charge shall proceed in accordance with Sub-Clause 3.5 [Determinations] to agree or determine this Cost, which shall be included in the Contract Price.
15. Contract Price, Payment and Lien		
Contract price	15.1	<p>Unless otherwise stated in the Particular Conditions:</p> <ol style="list-style-type: none"> i. the Contract Price shall be agreed or determined and be subject to adjustments in accordance with the Contract; ii. the Contractor shall pay all taxes, duties and fees required to be paid by him under the Contract, and the Contract Price shall not be adjusted for any of these Costs except as stated in Sub-Clause 15.21

		<p>[Adjustments for Changes in Legislation] or Price adjustment;</p> <p>iii. any quantities which may be set out in the Bill of Quantities or other Schedule are estimated quantities and are not to be taken as the actual and correct quantities:</p> <p>(a) of the Works which the Contractor is required to execute, or</p> <p>(b) for the purposes of Sub-Clause 11 [Measurement and Evaluation]; and</p> <p>iv. the Contractor shall submit to the Engineer-in-charge, within 28 Days after the Commencement Date, a proposed breakdown of each lump sum price in the Schedules. The Engineer-in-charge may take account of the breakdown when preparing Payment Certificates, but shall not be bound by it.</p>
Lump sum provisions in Estimate/ Contract	15.2	<p>When the estimate includes lump sum provisions primarily in respect of parts of work/ items whose specifications and costs are not known at the time of framing the Estimate, and if a bid is to be invited on such an estimate, such lump sum shall be excluded from the bid.</p> <p>Subsequently, when the specifications and costs of such items are known, their execution, if to be completed concurrently with the Contract, shall either be done as a variation item or on market rates (without bid premium) of the Contract. Such variation should be approved by the competent authority and then the Contractor shall be entitled to payment in respect of such items of work, or separate bids shall be invited for the work to be executed concurrently with the present Contract.</p>
Schedule of Payments (in case of Lump Sum Contract payments shall be linked to various stages of completion of Works given in the Activity Schedule)	15.3	<p>The schedule of payments shall be as included in the Contract. If the Contract does not include a schedule of payments, the Contractor shall submit non-binding estimates of the payments which he expects to become due during each quarterly period. The first estimate shall be submitted within 28 Days after the Commencement Date. Revised estimates shall be submitted at quarterly intervals, until the Taking-Over Certificate has been issued for the Works. The percentage quoted in the Bid and accepted in the Contract will be deducted/added from/to the gross amount of the bill.</p>
Application for Interim Payment Certificates (Running Account Bills)	15.4	<p>The Contractor shall submit a Statement in required number of copies to the Engineer-in-Charge after the end of each month, in a form approved by the Engineer-in-Charge, showing in detail the amounts to which the Contractor considers himself to be entitled on the basis of measurement (or Activity Schedule in case of Lump sum Contract) and advance payment, secured advance, deductions, etc. as applicable, together with supporting documents which shall</p>

		include the report on the progress during this month in accordance with Sub-Clause 4.20 [Progress Reports].
Issue of Interim Payment Certificates	15.5	<p>No amount will be certified or paid until the Procuring Entity has received and accepted the Performance Security. Thereafter, the Engineer-in-charge shall, within 28 Days after receiving a Statement and supporting documents, deliver to the Procuring Entity and to the Contractor an Interim Payment Certificate which shall state the amount which the Engineer-in-charge fairly determines to be due, with all supporting particulars for any reduction or withholding made by the Engineer-in-charge on the Statement, if any.</p> <p>However, prior to issuing the Taking Over Certificate for the Works, the Engineer-in-charge shall not be bound to issue an Interim Payment Certificate in an amount which would (after retention and other deductions) be less than the minimum amount of Interim Payment Certificate (if any) stated in the Contract Data. In this event, the Engineer-in-charge shall give notice to the Contractor accordingly.</p> <p>An Interim Payment Certificate shall not be withheld for any other reason, although:</p> <ol style="list-style-type: none"> i. if anything supplied or work done by the Contractor is not in accordance with the Contract, the cost of rectification or replacement may be withheld until rectification or replacement has been completed; and/or ii. if the Contractor was or is failing to perform any work or obligation in accordance with the Contract, and had been so notified by the Engineer-in-charge, the value of this work or obligation may be withheld until the work or obligation has been performed. <p>The Engineer-in-charge may in any Payment Certificate make any correction or modification that should properly be made to any previous Payment Certificate. A Payment Certificate shall not be deemed to indicate the Engineer-in-charge's acceptance, approval, consent or satisfaction.</p>
Payment of an Interim Payment Certificate	15.6.1	A bill shall be submitted by the Contractor each month on or before the date fixed by the Engineer-in-charge for all work executed in the previous month and the Engineer-in-charge shall take or cause to be taken or check the requisite measurement for the purpose of having the same verified and the claim, as far as admissible, authorized or paid, if possible, before the expiry of thirty days from the presentation for the bill. If the contractor does not submit the bill within the time fixed, as aforesaid, the Engineer-in-

		charge may depute a subordinate to measure up the said work in the presence of the Contractor, whose signature in the Measurement Book or sheet will be sufficient warrant and the Engineer-in-charge may prepare a bill from such Measurement Book, which shall be binding on the Contractor in all respects.
Payment at Part Rates	15.6.2	The rates for several items of works may be paid in part rates provisionally in running bills in proportion to the quantum of items executed as per specifications at the discretion of the Engineer-in-charge. The deferred payment, will however, be released after the successful completion of the item of work. In case of item rates, if the rate quoted for certain items is very high in comparison to the average/overall bid value over the estimated cost of the work, the payment at running stages shall not be made until an appropriate additional performance security for items for which rates have been quoted high, has been submitted by the Contractor. This security shall be refunded at the final stage of completion.
Payment at Reduced Rates	15.6.3	In case certain item of the Works has not been executed as per specifications, design, drawings and the specified durability and the Engineer-in-Charge is not convinced to accept the item of Works at the full rate applicable under the Contract, may accept such item at a reduced rate (in proportion to the designed and executed capability and or the designed and assessed service life of the structure and its components) with a minimum reduction of 25% of the full rate during the preparation of on account bills or final bill if the item is so acceptable without detriment to the safety and utility of the item and the whole Works. Decision of the Engineer-in-Charge to be conveyed in writing in respect of the same will be final and binding on the Contractor.
Recovery of Cost of Water and Electricity consumed by the Contractor	15.6.4	The cost of all water connections necessary for the execution of Works, and the cost of water consumed and hire charges of meters and the cost of electricity consumed in connection with the execution of the Works shall be paid by the Contractor except where otherwise specifically provided in the Contract Data.
Recovery of materials issued and hire charges of Machinery and Equipment, etc.	15.6.5	Recoveries on account of materials issued to the Contractor by the Procuring Entity, Machinery and Equipment lent on hire, advance payment, secured advance, etc. or on any other account, and dues shall be made from each payment certificate from the Contractor as per conditions of this Contract.
Payment on Intermediate Certificate to	15.7	All interim payments shall be regarded as payment by way of advances against final payment only and shall not preclude the requiring of bad, unsound and imperfect or

be regarded as Advances		unskilled work to be rejected, removed, taken away and reconstructed or re-erected. Any certificate given by the Engineer-in-Charge relating to the work done or Materials delivered forming part of such payment may be modified or corrected by any subsequent such certificate(s) or by the final certificate and shall not by itself be conclusive evidence that any work or Materials to which it relates is/are in accordance with the Contract and Specifications. Any such interim payment, or any part thereof shall not in any respect conclude, determine or affect in any way powers of the Engineer-in-Charge under the Contract or any of such payments be treated as final settlement and adjustment of accounts or in any way vary or affect the Contract.
Application for issue of final completion certificate	15.8	The Contractor shall apply to the Engineer-in-Charge for issue of the Final Completion Certificate at least 45 days in advance of the likely date of full/ satisfactory completion. The Engineer-in-Charge during this period shall review and finalise the requirements of work to qualify as final completion with respect to the third party quality inspection agency reports, if any. The Final completion certificate shall be issued within 30 days of its becoming due as per notice.
issue of final completion certificate	15.9	After the Contractor has rectified all deficiencies pointed out by the Engineer-in-Charge in the final payment documents, and complied to all observations of the Third Party Quality Inspection Agency and the Independent Engineer to the entire satisfaction of the Engineer-in-Charge, the Contractor shall apply to the Engineer-in-Charge releasing the final payment as per final statement and also issue a final payment certificate. The Engineer-in-Charge shall proceed to issue the final payment certificate after reviewing all tests on completion, determinations, as built design and drawings, and other compliances required under the Contract.
Final Statement of payments	15.10	Within 28 Days after receiving the Taking Over Certificate for the Works, the Contractor shall submit to the Engineer-in-charge, six copies of a draft final statement with as built drawings (with two soft copies also) and all other supporting documents showing in detail in a form approved by the Engineer-in-charge the value of all work done in accordance with the Contract, and any further sums which the Contractor considers to be due to him under the Contract or otherwise. If the Engineer-in-charge disagrees with or cannot verify any part of the draft final statement, the Contractor shall submit such further information as the Engineer-in-charge may reasonably require within 28 Days from receipt of said draft and shall make such changes in the draft as may be

		<p>agreed between them. The Contractor shall then prepare and submit to the Engineer-in-charge the final statement as agreed. This agreed statement is referred to in these Conditions as the "Final Statement".</p> <p>However if, following discussions between the Engineer-in-charge and the Contractor and any changes to the draft final statement which are agreed, it becomes evident that a dispute exists, the Engineer-in-charge shall deliver to the Procuring Entity's competent authority (with a copy to the Contractor) an Interim Payment Certificate for the agreed parts of the draft final statement.</p>
Discharge	15.11	<p>When submitting the Final Statement, the Contractor shall submit a discharge which confirms that the total of the Final Statement represents full and final settlement of all moneys due to the Contract or under or in connection with the Contract. This discharge may state that it becomes effective when the Contractor has received the Performance Security and the outstanding balance of this total, in which event the discharge shall be effective on such date.</p>
Payment of Final Bill	15.12	<p>The final value of the acceptable works done, less payments already received, value of claims raised and paid, value of claims not paid along with Interim Payment Certificates, final statement of price escalation due and paid, etc. shall be submitted by the Contractor along with the Final Bill. The final bill shall be submitted by the Contractor in the same manner as specified in interim bills within three Months of physical completion of the work or within one month of the date of the final certificate of completion issued by the Engineer-in-Charge whichever is earlier. No further claims shall be made by the Contractor after submission of the final bill and these shall be deemed to have been waived and extinguished.</p> <p>Payments of those items of the bill in respect of which there is no dispute and of items in dispute, for quantities and rates as approved by Engineer-in-Charge, will, as far as possible be made within a period of 90 days, the period being reckoned from the date of receipt of the bill by the Engineer-in-Charge complete with accounts of advances, Materials issued, Machinery & Equipment lent on hire by the Procuring Entity, dismantled Materials, etc.</p>
Recovery of cost of preparation of the bill	15.13	<p>In case the Contractor does not submit the bill within the time fixed, the Engineer-in-charge may prepare the bill as per provision of Sub-Clause 15.6.1 [Payment of an Interim Payment Certificate] but a deduction @ 0.5 % of the amount of such a bill shall be made and credited to the general revenue account of the Department/ Organisation on account of preparation of the bill.</p> <p>The Contractor shall submit all bills on the printed forms, to</p>

		be had on application, at the office of the Engineer- in-charge and the charges in the bills shall always be entered at the rates specified in the Contract or in the case of any extra work ordered in pursuance of these conditions, and not mentioned or provided for in the Contract, at the rates approved for such work.
Payment of Contractor's Bills to Banks	15.14	<p>Payments due to the Contractor may, if so desired by him, be made to his Bank instead of direct to him provided that the Contractor furnishes to the Engineer-in-Charge (i) the account number with name and address of branch of the Bank, (ii) an authorization in the form of a legally valid document such as a power of attorney conferring authority on the Bank to receive payments, and (iii) his own acceptance of the correctness of the amount made out as being due to him by Procuring Entity or his signature on the bill or other claim preferred against Procuring Entity before settlement by the Engineer-in-Charge of the account or claim by payment to the Bank. While the receipt given by such copy of Banks statement shall constitute a full and sufficient discharge for the payment, the Contractor shall also acknowledge with a receipt. Wherever possible the Contractor shall present his bills duly receipted and discharges through his Bankers. Nothing herein contained shall operate to create in favour of the Bank any rights or equities vis.-a-vis. the Procuring Entity/ Governor of Rajasthan.</p>
Advance Payments	15.15	<p>If provided in the SCC/ Contract Data, the Procuring Entity shall make an advance payment on simple interest (rate as specified in SCC) as an mobilization for the Works, when the Contractor submits a Bank Guarantee of an equal amount from a Scheduled Bank in India. The total advance payment, the number and timing of installments (if more than one), and the applicable currencies and proportions, shall be as stated in the Contract Data.</p> <p>Unless and until the Procuring Entity receives this Bank Guarantee and got confirmed from the issuing Bank, or if the provision of advance payment is not stated in the Contract Data, this Sub-Clause shall not apply.</p> <p>Unless stated otherwise in the Contract Data, the advance payment shall be repaid through percentage deductions from the interim payments determined by the Engineer-in-charge in accordance with Sub-Clause 15.5 [Issue of Interim Payment Certificates], as follows</p> <ol style="list-style-type: none"> i. deductions shall commence in the next interim Payment Certificate following that in which the total of all certified interim payments (excluding the advance payment and deductions and repayments of retention) exceeds 30 percent of the Accepted Contract Amount less Provisional Sums; and ii. deductions shall be made at the amortisation rate stated

		<p>in the Contract Data of the amount of each Interim Payment Certificate (excluding the advance payment and deductions for its repayments as well as deductions for retention money) in the currencies and proportions of the advance payment until such time as the advance payment has been repaid; provided that the advance payment shall be completely repaid prior to the time when 90 percent of the Accepted Contract Amount less Provisional Sums has been certified for payment.</p> <p>If the advance payment has not been repaid prior to the issue of the Taking-Over Certificate for the Works or prior to termination under Sub-Clause 16.1 [Termination by Procuring Entity], Sub-Clause 17.2 [Termination by Contractor] or Sub-Clause 19 [Force Majeure] (as the case may be), the whole of the balance then outstanding shall immediately become due to the Procuring Entity.</p>
<p>Secured Advance on Non-Perishable Materials</p> <p><i>(Not applicable in case of Lump Sum Contract)</i></p>	15.16	<p>The Contractor, on signing an indenture in the form to be specified by the Engineer-in-Charge, may be paid during the progress of the execution of the work, up to 75% of the assessed value of any Materials which have been actually brought at the Site and which, in the opinion of the Engineer-in-charge, are non-perishable, non-fragile and non-combustible and will be consumed in the Works within next three months in accordance with the construction programme and the Contract provided that they are adequately stored and/ or protected against damage by weather or other causes but which have not, at the time of granting advance, been incorporated in the Works. When Materials on account of which advance has been made under this Sub-Clause are incorporated in the work, the amount of such advance shall be recovered/ deducted from the next payment made under any of the Sub-Clauses of this Contract.</p>
<p>Ensuring Payment and Amenities to Workers if Contractor fails to pay</p>	15.17	<p>In every case in which by virtue of the provisions of the Contract Labour (Regulation and Abolition) Act, 1970, and of the Contract Labour (Regulation and Abolition) Central Rules, 1971, any applicable Labour Laws, the Procuring Entity is obliged to pay any amounts of wages to a workman employed by the Contractor in execution of the Works, or to incur any expenditure in providing welfare and health amenities required to be provided under the above said Laws or under the P.W.D. Contractor's Labour Regulations, or under the Rules framed by Government from time to time for the protection of health and sanitary arrangements for workers employed by the Contractor, the Procuring Entity shall recover from the Contractor the amount of wages so paid or the amount of expenditure so incurred; and without prejudice to the rights of the Procuring Entity under sub-section (2) of Section 20, and sub-section (4) of Section 21, of the Contract Labour</p>

		(Regulation and Abolition) Act, 1970, Government shall be at liberty to recover such amount or any part thereof by deducting it from the Performance Security or from any sum due by the Procuring Entity to the Contractor whether under this Contract or otherwise. The Procuring Entity shall not be bound to contest any claim made against it under sub-section (1) of Section 20, sub-section (4) of Section 21, of the said Act, except on the written request of the Contractor and upon his giving to the Procuring Entity full security for all costs for which the Procuring Entity might become liable in contesting such claim.
Withholding and lien in respect of sums due from Contractor	15.18	<p>i. Whenever any claim or claims for payment of a sum of money arises out of or under the Contract or against the Contractor, the Engineer-in-Charge or the Government shall be entitled to withhold and also have a lien to retain such sum or sums in whole or in part from the Performance Security, if any, deposited by the Contractor and for the purpose aforesaid, the Engineer-in-Charge or the Government shall be entitled to withhold the Performance Security furnished, if any and also have a lien over the same pending finalization or adjudication of any such claim. In the event of the security being insufficient to cover the claimed amount or amounts or if no security has been taken from the Contractor, the Engineer-in-Charge or the Government shall be entitled to withhold and have a lien to retain to the extent of payable or which may at any time thereafter become payable to the Contractor under the same Contract or any other Contract with the Engineer-in-Charge or the Government or any Contracting person through the Engineer-in-Charge pending finalization of adjudication of any such claim. It is an agreed term of the Contract that the sum of money or moneys so withheld or retained under the lien referred to above by the Engineer-in-Charge or Government will be kept withheld or retained as such by the Engineer-in-Charge or Government till the claim arising out of or under the Contract is determined by the arbitrator (if the Contract is governed by the arbitration Sub-Clause) or by the competent court, as the case may be and that the Contractor will have no claim for interest or damages whatsoever on any account in respect of such withholding or retention under the lien referred to above and duly notified as such to the Contractor. For the purpose of this Sub-Clause, where the Contractor is a partnership firm or a limited company, the Engineer-in-Charge or the Government shall be entitled to withhold and also have a lien to</p>

		<p>retain towards such claimed amount or amounts in whole or in part from any sum found payable to any partner/ limited company as the case may be, whether in his individual capacity or otherwise.</p> <p>ii. The Procuring Entity shall have the right to cause an audit and technical examination of the Works and the final bills of the Contractor including all supporting vouchers, abstract etc., to be made within two years after payment of the final bill and if as a result of such audit and technical examination any sum is found to have been overpaid in respect of any work done by the Contractor under the Contract or any work claimed to have been done by him under the Contract and found not to have been executed, the Contractor shall be liable to refund the amount of over-payment and it shall be lawful for the Procuring Entity to recover the same from him in the manner prescribed or in any other manner legally permissible; and if is found that the Contractor was paid less than what was due to him under the Contract in respect of any work executed by him under it, the amount of such under payment shall be duly paid by the Procuring Entity to the Contractor, without any interest thereon whatsoever.</p>
Lien in respect of claims in other Contracts	15.19	<p>Any sum of money due and payable to the Contractor (including the Performance Security returnable to him) under the Contract may be withheld or retained by way of lien by the Engineer-in-Charge or the Government or any other Contracting person or persons through Engineer-in-charge against any claim of the Engineer-in-Charge or the Government or such person or persons in respect of payment of a sum of money arising out of or under any other Contract made by the Contractor with the Engineer-in-Charge or the Government or with such person or persons.</p> <p>It is an agreed term of the Contract that the sum of money so withheld or retained under this Sub-Clause by the Engineer-in- Charge or the Government will be kept withheld or retained as such by the Engineer-in-Charge or the Government till his claim arising out of the same Contract or any other Contract is either mutually settled or determined by the arbitration Sub-Clause or by the competent court, as the case may be and that the Contractor shall have no claim for interest or damages whatsoever on this account or on any other ground in respect of any sum of money withheld or retained under this Sub-Clause and duly notified as such to the Contractor.</p>
Levy or Taxes payable by	15.20	<p>i. VAT/ Sales Tax , service tax or any other taxes and duties on Materials, works or services in respect of</p>

Contractor		<p>this Contract shall be payable by the Contractor according to Law in effect.</p> <p>ii. The Contractor shall deposit royalty and obtain necessary permit for supply of the red earth, moorum, sand, chips, bajri, stone, kankar, etc. from local authorities. The liability, if any, on account of quarry fees, royalties, octroi and other taxes and duties in respect of materials actually consumed on the Works, shall be borne by the Contractor.</p> <p>iii. If pursuant to or under any Law, notification or order any royalty, cess or the hike becomes payable to the Government of India and does not at any time become payable by the Contractor to the State Government/ Local authorities in respect of any Material used by the Contractor in the Works then in such a case, it shall be Lawful to the Government of India and it will have the right and be entitled to recover the amount paid in the circumstances as aforesaid from the dues of the Contractor.</p> <p>iv. In respect of goods and Materials procured by the Contractor, for use in Works under the Contract, VAT will be paid by the Contractor himself but in respect of such goods manufactured and supplied by the Contractor and Works executed under the contract, the responsibility of payment of VAT shall be that of the Procuring Entity.</p>
Adjustments for changes in Legislation	15.21	<p>i All the bid rates shall be inclusive of all taxes and levies payable under respective statutes, However if any further tax or levy is imposed by Statute, after the Base Date and the Contractor thereupon necessarily and properly pays such taxes/ levies the Contractor shall be reimbursed the amount so paid, provided such payments, if it any, is not, in the opinion of the Procuring Entity (whose decision shall be final and binding on the Contractor) attributable to delay in execution of work within the control of the Contractor.</p> <p>ii The Contractor shall keep necessary books of accounts and other documents for the purpose of this condition as may be necessary and shall allow inspection of the same by a duly authorized representative of the Procuring Entity and/ or the Engineer-in-Charge and further shall furnish such other information/ document as the Engineer-in-Charge may require from time to time.</p> <p>iii The Contractor shall, within a period of 30 Days of the imposition of any such further tax or levy, give a written notice thereof to the Engineer-in-Charge that the same is given pursuant to this condition, together with all necessary information relating thereto.</p> <p>This Sub-Clause shall not be applicable if the effect of</p>

		changes in legislation has been included in price variation formulae in Clause 10 [Price Variation].
Pre Check and Post Check of Bills	15.22	The Government/ Procuring Entity shall have a right to provide a system of pre check of Contractor's bills by a specified organization and payment by an Accounts Organisation as the Government/ Procuring Entity may in its absolute discretion decide. Any overpayments detected as a result of such pre check or post check of Contractor's bills can be recovered from the Contractor's bills and the Contractor will refund such excess payments.
16. Termination of Contract by Procuring Entity		
Termination by Procuring Entity	16.1	<p>Subject to the other provisions contained in this Sub-Clause the Engineer-in-charge may, without prejudice to his any other rights or remedy against the Contractor in respect of any delay, inferior workmanship, any claims for damages and/or any other provisions of this Contract or otherwise and whether the date of completion has or has not elapsed by a notice of reasonable period in writing absolutely determine the Contract in any of the following cases:</p> <ul style="list-style-type: none"> i If the Contractor, having been given by the Engineer-in-Charge a notice in writing to rectify, reconstruct or replace any defective work or that the work is being performed in an inefficient or otherwise improper or un-workmanlike manner, or by workers who do not understand the instructions of the Engineer-in-Charge, or do not execute the work as per specifications or in contravention of the advice of the third party quality inspections agency about the quality of works, if any, shall omit to comply with the requirement of such notice for a period of fifteen Days thereof. ii If the Contractor being a company shall pass a resolution or the Court shall make an order that the company shall be wound up or if a receiver or a manager on behalf of a creditor shall be appointed or if circumstances shall arise which entitle the Court or the creditor to appoint a receiver or a manager or which entitle the Court to make a winding up order. iii If the Contractor has, without reasonable cause, suspended the progress of the Works for a continuous period of 30 days, or has failed to proceed with the Works with due diligence so that, in the reasoned opinion of the Engineer-in-Charge (which shall be final and binding), he will be unable to secure completion of the Works by the stipulated date of completion and continues to do so after a notice in writing of fifteen Days from the Engineer-in-Charge. iv If the Contractor fails to complete the Works within

		<p>the stipulated time or spans of the Works with individual date of completion, if any stipulated, on or before such date(s) of completion and or fails to achieve two continuous mile stones, does not complete them within the period specified in a notice given in writing on that behalf by the Engineer-in-Charge.</p> <p>v If the Contractor persistently neglects to carry out his obligations under the Contract and/ or commits default in complying with any of the terms and conditions of the Contract and does not remedy it or take effective steps to remedy it within fifteen Days after a notice in writing is given to him on that behalf by the Engineer-in-charge.</p> <p>vi If the Contractor sublets the Works or a part of Works without specific permission of the Procuring Entity/ Engineer-in-charge.</p> <p>vii If the Contractor has not been commenced the Works by the Commencement Date or within 1/8th of the stipulated time for completion subject to a maximum of 45 Days, whichever is earlier.</p> <p>When the Contractor has made himself liable for action under any of the cases aforesaid, the Engineer-in-Charge on behalf of the Procuring Entity shall have the powers:</p> <p>(a) To determine or rescind the Contract as aforesaid (of which a 28 days termination or rescission notice in writing to the Contractor under the hand of Engineer-in-Charge shall be conclusive evidence). Upon such determination or rescission the Bid Security and Performance Security under the Contract shall be liable to be forfeited and shall be absolutely at the disposal of the Procuring Entity.</p> <p>(b) To employ labour paid by the Procuring Entity and to supply materials to carry out the Works or any part of the Works, debiting the Contractor with the cost of the labour and the price of the materials (of the amount of which cost and price certified by the Engineer-in-charge shall be final and conclusive against the Contractor) and crediting him with the value of the work done in all respects in the same manner and at the same rates, as if it has been carried out by the Contractor under the terms of this Contract. The certificate of the Engineer-in-Charge, as to the value of the work done, shall be final and conclusive evidence against the Contractor provided always that action under the sub Sub-Clause shall only be taken after giving notice in writing to the Contractor. Provided also that if the expenses incurred by the Procuring Entity are less than the amount payable to the Contractor at his agreement rates, the difference shall not be paid to</p>
--	--	--

		<p>the Contractor.</p> <p>(c) After giving notice specifying the date and time to the Contractor to measure up the acceptable (executed as per design, drawings and specifications) work of the Contractor at Site and to take such part thereof, as shall be unacceptable out of his hands and to give it to another contractor to complete, in which case any expenses which may be incurred in excess of the sum which would have been paid to the original Contractor, if the whole work had been executed by him (of the amount of which excess, the certificate in writing of the Engineer-in-charge shall be final and conclusive) shall be borne and paid by the original Contractor and may be deducted from any money due to him by the Procuring Entity under this Contract or any other account, whatsoever, or from his Bid Security, Performance Security or the Enlistment Security or the proceeds of sale thereof, or a sufficient part thereof as the case may be.</p> <p>In the event of any one or more of the above courses being adopted by the Engineer-in-charge the contractor shall have no claim to compensation for any loss sustained by him by reason of his having purchased or procured any materials or entered into any engagements or made any advances on account or with a view to the execution of the Works or the performance of the Contract.</p> <p>In case action is taken under any of the aforesaid provisions, the Contractor shall not be entitled to recover or be paid any sum for any work thereof or actually performed under this Contract unless and until the Engineer-in-charge has certified in writing the performance of such work and value payable in respect thereof and he shall only be entitled to be paid the value so certified.</p>
<p>Contractor liable to pay compensation even if action not taken under Sub-Clause 16.1 above</p>	<p>16.2</p>	<p>i In any case in which the powers conferred upon the Engineer- in-Charge by Sub-Clause 16.1 [Termination by Procuring Entity] shall have become exercisable and the same are not exercised, the non-exercise of such powers shall not constitute a waiver of any of the conditions hereof and such powers shall, notwithstanding, be exercisable in the event of any future case of default by the Contractor and the liability of the Contractor for compensation shall remain unaffected.</p> <p>ii In the event of the Engineer-in-Charge putting in force all or any of the powers vested in him under the preceding Sub-Clause 16.1, he may, if he so desires, after giving a notice in writing to the Contractor, take possession of all or any tools, plants, materials and stores, in or upon the Works or the Site, thereof or</p>

		<p>belonging to the Contractor or procured by him and intended to be used for execution of the Works or any part thereof, paying or allowing for the same in account, at the Contract rates or, in the case of these not being applicable, at current market rates to be certified by the Engineer-in-Charge (whose certificate, thereof, shall be final and conclusive), otherwise the Engineer-in-Charge may, by notice in writing to the Contractor or his authorized agent, require him to remove such tools, plants, materials or stores from the premises (within a time to be specified in such notice), and in the event of the Contractor failing to comply with any such requisition, the Engineer-in-Charge may remove them at the Contractor's expense or sell them by auction or private sale on account of the Contractor and his risk in all respects, and the certificate of the Engineer-in-Charge as to the expenses of any such removal, and the amount of the proceeds and expenses of any such sale shall be final and conclusive against the Contractor.</p>
Valuation at the date of termination:	16.3	<p>As soon as practicable after a notice of termination under Sub-Clause 16.1 has taken effect, the Engineer-in-charge shall proceed in accordance with Sub-Clause 3.5 [Determinations] to agree or determine the value of the Works, Goods and Contractor's Documents, and any other sums due to the Contractor for work executed in accordance with the Contract.</p>
Payment after Termination	16.4	<p>After a notice of termination under Sub-Clause 16.1 has taken effect, the Procuring Entity may:</p> <ul style="list-style-type: none"> i proceed in accordance with Sub-Clause 3.5 [Procuring Entity's Claims], ii withhold further payments to the Contractor until the Costs of execution, completion and remedying of any Defects, damages for delay in completion (if any), and all other Costs incurred by the Procuring Entity, have been established, and iii recover from the Contractor any losses and damages incurred by the Procuring Entity and any extra Costs of completing the Works, after allowing for any sum due to the Contractor under Sub-Clause 16.3. After recovering any such losses, damages and extra Costs, the Procuring Entity shall pay balance to the Contractor, if any.
Procuring Entity's Entitlement to Termination for Convenience	16.5	<p>If, at any time after the commencement of the Works, the Government/ Procuring Entity shall, for any reason, whatsoever, not require the whole work, thereof, as specified in the Contract, to be carried out, the Engineer-in-charge shall give notice, in writing, of the fact to the Contractor, who shall have no claim to any payment or compensation, whatsoever, on account of any profit or</p>

		<p>advantage which he might have derived from the execution of the Works in full but which he did not derive in consequence of the full amount of the Works not having been carried out. Neither shall he have any claim for compensation by reason of alterations having been made in the original specifications, drawings and design and instructions, which shall involve any curtailment of the Works, as originally contemplated. Provided, that the contractor shall be paid the charges for the cartage only, of materials actually brought to the Site of the Works by him for bonafide use and rendered surplus as a result of the abandonment or curtailment of the Works or any portion thereof, and taken them back by the Contractor provided, however, that the Engineer-in-charge shall have, in all such cases, the option of taking over all or any such materials at their purchase price or at local market rates whichever may be less.</p>
<p>Corrupt, Fraudulent, Collusive or Coercive Practices</p>	<p>16.6</p>	<p>If the Procuring Entity determines that the Contractor, his Sub-Contractors or any of their personnel has breached the Code of Integrity prescribed in the Act, the Rules, or the Instructions to Bidders [Section I of the Bidding Document] or has engaged in corrupt, fraudulent, collusive or coercive practices, in competing for or in executing the Contract, then the Procuring Entity may, after giving 14 Days notice to the Contractor:</p> <ul style="list-style-type: none"> i terminate the Contract and expel him from the Site, ii forfeit or encash performance security and any other security or bond relating to this Contract, iii recover the payments made under the Contract along with interest thereon at bank rate, iv recover compensation for loss incurred due to termination of the Contract including excess expenditure, if any incurred in getting the remaining work executed from other agency under Sub-Clause 16.1. <p>For the purposes of this Sub-Clause:</p> <ul style="list-style-type: none"> i “corrupt practice” means the offering, giving, receiving or soliciting, directly or indirectly, of anything of value to influence the action of a public official in the procurement process or in the Contract execution; ii “fraudulent practice” means a misrepresentation or omission of facts in order to influence a procurement process or the execution of the Contract; iii “collusive practice” means a scheme of arrangement between two or more bidders, with or without the knowledge of the Procuring Entity, designed to establish bid prices at artificial, non-competitive levels; iv “Coercive practice” means harming or threatening to

		<p>harm, directly or indirectly, persons or their property to influence their participation in the procurement process or affect the execution of a Contract.</p> <p>Should any employee of the Contractor be determined to have engaged in corrupt, fraudulent or coercive practice during the execution of the Works then that employee shall be removed in accordance with Sub-Clause 6.11 [Contractor's Personnel].</p>
Termination of Contract on death of Contractor	16.7	Without prejudice to any of the rights or remedies under this Contract, if the Contractor dies, the Procuring Entity shall have the option of terminating the Contract without compensation to the Contractor after the affidavit of his/ their legal heir/heirs that they are not in a position to complete the work as Contracted or are not going to be in this profession in future.
17. Suspension of Works and Termination by the Contractor		
Contractor's Entitlement to Suspend Work	17.1	<p>If the Engineer-in-charge fails to certify an Interim Payment Certificate in accordance with Sub-Clause 15.5 [Issue of Interim Payment Certificates] or fails to make a payment of an Interim Payment Certificate within time period specified in accordance with Sub-Clause 15.6 [Payment of an Interim Payment Certificate], the Contractor may, after giving not less than 21 Days' notice to the Procuring Entity, suspend work (or reduce the rate of progress of work) unless and until the Contractor has received the Payment Certificate or payment, as the case may be as described in the notice.</p> <p>If the Contractor subsequently receives such Payment Certificate or payment (as described in the relevant Sub-Clause and in the above notice) before giving a notice of termination, the Contractor shall resume normal working as soon as is reasonably practicable.</p> <p>If the Contractor suffers delay and/ or incurs Cost as a result of suspending the Works (or reducing the rate of progress of the Works) in accordance with this Sub-Clause, the Contractor shall give notice to the Engineer-in-charge and shall be entitled subject to Sub-Clause 21.2 [Contractor's Claims] to:</p> <ul style="list-style-type: none"> i an extension of time for any such delay, if completion is or will be delayed, under Sub-Clause 8.6 [Extension of Time for Completion], and ii payment of any such Cost, which shall be included in the Contract Price. <p>After receiving this notice, the Engineer-in-charge shall proceed in accordance with Sub-Clause 3.5 [Determinations] to agree or determine these matters.</p>
Termination by Contractor	17.2	<p>The Contractor shall be entitled to terminate the Contract if:</p> <ul style="list-style-type: none"> i the Contractor does not receive the amount due

		<p>under an Interim Payment Certificate within 28 Days after the expiry of the time stated in Sub-Clause 15.6 [Payment of an Interim Payment Certificate] within which payment is to be made (except for deductions in accordance with Sub-Clause 2.5 [Procuring Entity's Claims], or</p> <p>ii the Procuring Entity substantially fails to perform his obligations under the Contract in such manner as to materially and adversely affect the economic balance of the Contract and/ or the ability of the Contractor to perform the Contract, or</p> <p>iii a prolonged suspension affects the whole of the Works as described in Sub-Clause 8.13 [Prolonged Suspension], or</p> <p>iv the Contractor does not receive the Engineer-in-charge's instruction recording the agreement of both Parties on the fulfilment of the conditions for the Commencement of Works under Sub-Clause 8.3 [Commencement of Works].</p> <p>In any of these events or circumstances, the Contractor may, upon giving 28 Days' reasoned notice to the Procuring Entity, terminate the Contract.</p>
Cessation of Work and Removal of Contractor's Equipment	17.3	<p>After a notice of termination under Sub-Clause 16 [Termination of Contract by Procuring Entity], Sub-Clause 17.2 [Termination by Contractor] or Sub-Clause 19.6. [Optional Termination, Payment and Release] has taken effect, the Contractor shall promptly:</p> <p>i cease all further work, except for such work as may have been instructed by the Engineer-in-charge for the protection of life or property or for the safety of the Works,</p> <p>ii hand over Contractor's Documents, as built drawings, Plant, Materials and other work, for which the Contractor has received payment, and</p> <p>iii remove all other Goods from the Site, except as necessary for safety, and leave the Site.</p>
Payment on Termination	17.4	<p>After a notice of termination under Sub-Clause 17.2 [Termination by Contractor] has taken effect, the Procuring Entity shall promptly pay the Contractor in accordance with Sub-Clause 19.6. [Optional Termination, Payment and Release].</p>
18. Risk and responsibilities		
Indemnities	18.1	<p>The Contractor shall indemnify and hold harmless the Procuring Entity, the Procuring Entity's Personnel, and their respective agents, against and from all claims, damages, losses and expenses (including legal fees and expenses) in respect of:</p> <p>i bodily injury, sickness, disease or death, of any person whatsoever arising out of or in the course of</p>

		<p>or by reason of the Contractor's design (if any), the execution and completion of the Works and the remedying of any Defects, unless attributable to any negligence, willful act or breach of the Contract by the Procuring Entity, the Procuring Entity's Personnel, or any of their respective agents, and</p> <p>ii damage to or loss of any property, real or personal (other than the Works), to the extent that such damage or loss arises out of or in the course of or by reason of the Contractor's design (if any), the execution and completion of the Works and the remedying of any Defects, unless and to the extent that any such damage or loss is attributable to any negligence, willful act or breach of the Contract by the Procuring Entity, the Procuring Entity's Personnel, their respective agents, or anyone directly or indirectly employed by any of them.</p>
Contractor's Care of the Works	18.2.1	<p>The Contractor shall take full responsibility for the care of the Works and materials and Goods from the Commencement Date until the Taking-Over Certificate is issued (or is deemed to be issued under Clause 12 [Taking Over of the Works and Sections by Procuring Entity] for the Works, when responsibility for the care of the Works shall pass to the Procuring Entity. If a Taking-Over Certificate is issued (or is so deemed to be issued) for any Section or part of the Works, responsibility for the care of the Section or part shall then pass to the Procuring Entity. After responsibility has accordingly passed to the Procuring Entity, the Contractor shall take responsibility for the care of any work which is outstanding on the date stated in a Taking-Over Certificate, until this outstanding work has been completed.</p> <p>If any loss or damage happens to the Works, Materials or Goods or Contractor's Documents during the period when the Contractor is responsible for their care, from any cause not listed in Sub-Clause 18.3 [Procuring Entity's Risks], the Contractor shall rectify/ reimburse the loss or damage at the Contractor's risk and Cost, so that the Works, Materials or Goods or Contractor's Documents conform with the Contract.</p> <p>The Contractor shall be liable for any loss or damage caused by any actions performed by the Contractor after a Taking-Over Certificate has been issued. The Contractor shall also be liable for any loss or damage which occurs after a Taking Over Certificate has been issued and which arose from a previous event for which the Contractor was liable.</p>
	18.2.2	<p>All risks of loss of or damage to physical property and of personal injury and death which arise during and in consequence of the performance of the Contract other</p>

		than the excepted risks are the responsibility of the Contractor.
Procuring Entity's Risks.	18.3	<p>The risks referred to in Sub-Clause 18.4 [Consequences of Procuring Entity's Risks] below, insofar as they directly affect the execution of the Works, are:</p> <ul style="list-style-type: none"> i war, hostilities (whether war be declared or not), invasion, act of foreign enemies, ii rebellion, terrorism, sabotage by persons other than the Contractor's Personnel, revolution, insurrection, military or usurped power, or civil war, within the Country, iii riot, commotion or disorder within the Country by persons other than the Contractor's Personnel, iv munitions of war, explosive Materials, ionizing radiation or contamination by radio-activity, within the Country, except as may be attributable to the Contractor's use of such munitions, explosives, radiation or radio-activity, v pressure waves caused by aircraft or other aerial devices travelling at sonic or supersonic speeds, vi use or occupation by the Procuring Entity of any part of the Permanent Works, except as may be specified in the Contract, vii design of any part of the Works by the Procuring Entity's Personnel or by others for whom the Procuring Entity is responsible, and viii Any operation of the forces of nature which is Unforeseeable or against which an experienced Contractor could not reasonably have been expected to have taken adequate preventive precautions.
Consequences of Procuring Entity's Risks	18.4	<p>If and to the extent that any of the risks listed in Sub-Clause 18.3 above results in loss or damage to the Works, materials or Goods or Contractor's Documents, the Contractor shall promptly give notice to the Engineer-in-charge and shall rectify this loss or damage to the extent required by the Engineer-in-charge.</p> <p>If the Contractor suffers delay and/ or incurs Cost from rectifying this loss or damage, the Contractor shall give a further notice to the Engineer-in-charge and shall be entitled subject to Clause 21.2 [Contractor's Claims] to:</p> <ul style="list-style-type: none"> i An extension of time for any such delay, if completion is or will be delayed, under Clause 8.6 [Extension of Time for Completion], and ii payment of any such Cost, which shall be included in the Contract Price. <p>After receiving this further notice, the Engineer-in-charge shall proceed in accordance with Clause 3.5 [Determinations] to agree or determine these matters.</p>

Intellectual and Industrial Property Rights	18.5	<p>In this Sub-Clause, “infringement” means an infringement (or alleged infringement) of any patent, registered design, copyright, trade mark, trade name, trade secret or other intellectual or industrial property right relating to the Works; and “claim” means a claim (or proceedings pursuing a claim) alleging an infringement.</p> <p>Whenever a Party does not give notice to the other Party of any claim within 28 Days of receiving the claim, the first Party shall be deemed to have waived any right to indemnity under this Sub-Clause.</p> <p>The Contractor shall fully indemnify and keep indemnified the Procuring Entity and the State Government against any action, claim or proceeding relating to infringement or use of any patent or design or any alleged patent or design rights and shall pay any royalties which may be payable in respect of any article or part thereof included in the Contract. The Contractor shall indemnify and hold the Procuring Entity harmless against and from any other claim which arises out of or in relation to (i) the manufacture, use, sale or import of any Goods, or (ii) any design for which the Contractor is responsible.</p> <p>The Procuring Entity shall indemnify and hold the Contractor harmless against and from any claim alleging an infringement which is or was:</p> <ul style="list-style-type: none"> i an unavoidable result of the Contractor’s compliance with the Contract, or ii a result of any Works being used by the Procuring Entity: <ul style="list-style-type: none"> (a) for a purpose other than that indicated by, or reasonably to be inferred from, the Contract, or (b) in conjunction with anything not supplied by the Contractor, unless such use was disclosed to the Contractor prior to the Base Date or is stated in the Contract <p>If a Party is entitled to be indemnified under this Sub-Clause, the indemnifying Party may (at its Cost) conduct negotiations for the settlement of the claim, and any litigation or arbitration which may arise from it. The other Party shall, at the request and Cost of the indemnifying Party, assist in contesting the claim. This other Party (and its Personnel) shall not make any admission which might be prejudicial to the indemnifying Party, unless the indemnifying Party failed to take over the conduct of any negotiations, litigation or arbitration upon being requested to do so by such other Party.</p>
Limitation of Liability	18.6	<p>Neither Party shall be liable to the other Party for loss of use of any Works, loss of profit, loss of any Contract or for any indirect or consequential loss or damage which may be suffered by the other Party in connection with the Contract, other than as specifically provided in Sub-Clause 8.9 [Compensation/ Damages for Delay]; Sub-Clause 13.3</p>

		<p>[Cost of Remedying Defects]; Sub-Clause 16.4 [Payment after Termination]; Sub-Clause 17.4 [Payment on Termination]; Sub-Clause 18.1 [Indemnities]; Sub-Clause 18.2 [Contractor's Care of the Works], Sub-Clause 18.4 [Consequences of Procuring Entity's Risks] and Sub-Clause 18.5. [Intellectual and Industrial Property Rights].</p> <p>The total liability of the Contractor to the Procuring Entity, under or in connection with the Contract shall not exceed twice the Accepted Contract Amount. This amount does not include charges, if any, for consumption of Electricity, Water and Gas provided by the Procuring Entity under Sub-Clause 4.18 [Electricity, Water and Gas], and use of Procuring Entity's Equipment and Materials under Sub-Clause 4.19 [Procuring Entity's Equipment and Issue of Materials].</p> <p>This Sub-Clause shall not limit liability of the Contractor in any case of fraud, deliberate default or reckless misconduct by the Contractor or Sub-Contractors or their personnel or offences under any other Law for the time being in force.</p>
Use of Procuring Entity's Accommodation/ Facilities	18.7	<p>The Contractor shall take full responsibility for the care of the accommodation and facilities, if any, provided by the Procuring Entity as detailed in the Specifications, from the respective dates of hand-over to the Contractor until cessation of occupation (where hand-over or cessation of occupation may take place after the date stated in the Taking-Over Certificate for the Works).</p> <p>If any loss or damage happens to any of the above items while the Contractor is responsible for their care arising from any cause whatsoever other than those for which the Procuring Entity is liable, the Contractor shall, at his own cost, rectify the loss or damage to the satisfaction of the Engineer-in-Charge.</p>
19. Force Majeure		
Definition of Force Majeure	19.1	<p>In this Sub-Clause, "Force Majeure" means an exceptional event or circumstance:</p> <ol style="list-style-type: none"> i. which is beyond a Party's control, ii. which such Party could not reasonably have provided against before entering into the Contract, iii. which, having arisen, such Party could not reasonably have avoided or overcome, and iv. which is not substantially attributable to the other Party. <p>Force Majeure may include, but is not limited to, exceptional events or circumstances of the kind listed below, so long as conditions (i) to (iv) above are satisfied:</p> <ol style="list-style-type: none"> (a) war, hostilities (whether war be declared or not), invasion, act of foreign enemies, (b) rebellion, terrorism, sabotage by persons other than the Contractor's Personnel, revolution, insurrection, military or usurped power, or civil war,

		<p>(c) riot, commotion, disorder, strike or lockout by persons other than the Contractor's Personnel,</p> <p>(d) munitions of war, explosive Materials, ionizing radiation or contamination by radio-activity, except as may be attributable to the Contractor's use of such munitions, explosives, radiation or radio-activity, and</p> <p>(e) natural catastrophes such as earthquake, hurricane, typhoon or volcanic activity.</p>
Notice of Force Majeure	19.2	<p>If a Party is or will be prevented from performing its substantial obligations under the Contract by Force Majeure, then it shall give notice to the other Party of the event or circumstances constituting the Force Majeure and shall specify the obligations, the performance of which is or will be prevented. The notice shall be given within 14 Days after the Party became aware, or should have become aware, of the relevant event or circumstance constituting Force Majeure.</p> <p>The Party shall, having given notice, be excused performance of its obligations for so long as such Force Majeure prevents it from performing them.</p> <p>Notwithstanding any other provision of this Clause, Force Majeure shall not apply to obligations of either Party to make payments to the other Party under the Contract.</p>
Duty to Minimize Delay	19.3	<p>Each Party shall at all times use all reasonable endeavors to minimize any delay in the performance of the Contract as a result of Force Majeure.</p> <p>A Party shall give notice to the other Party when it ceases to be affected by the Force Majeure.</p>
Consequences of Force Majeure	19.4	<p>If the Contractor is prevented from performing its substantial obligations under the Contract by Force Majeure of which notice has been given under Sub-Clause 19.2 [Notice of Force Majeure], and suffers delay and/ or incurs Cost by reason of such Force Majeure, the Contractor shall be entitled subject to Sub-Clause 21.2 [Contractor's Claims] to:</p> <ol style="list-style-type: none"> i. an extension of time for any such delay, if completion is or will be delayed, under Sub-Clause 8.6 [Extension of Time for Completion], and ii. if the event or circumstance is of the kind described in Sub-Clause 19.1 [Definition of Force Majeure] and, in the case of sub-paragraphs (a) to (e), occurs in the Country, payment of any such Cost incurred rectifying or replacing the Works and/ or Goods damaged or destructed by Force Majeure, to the extent they are not indemnified through the insurance policy referred to in Sub-Clause 20.2 [Insurance for Works and Contractor's Equipment]. <p>After receiving this notice, the Engineer-in-charge shall proceed in accordance with Sub-Clause 3.5 [Determinations] to agree or determine these matters.</p>

Force Majeure Affecting Subcontractor	19.5	If any Subcontractor is entitled under any Contract or agreement relating to the Works to relief from force majeure on terms additional to or broader than those specified in this Sub-Clause, such additional or broader force majeure events or circumstances shall not excuse the Contractor's non-performance or entitle him to relief under this Sub-Clause.
Optional Termination, Payment and Release	19.6	<p>If the execution of substantially all the Works in progress is prevented for a continuous period of 84 Days by reason of Force Majeure of which notice has been given under Sub-Clause 19.2 [Notice of Force Majeure], or for multiple periods which total more than 140 Days due to the same notified Force Majeure, then either Party may give to the other Party a notice of termination of the Contract. In this event, the termination shall take effect 7 Days after the notice is given, and the Contractor shall proceed in accordance with Sub-Clause 17.3 [Cessation of Works and Removal of Contractor's Equipment].</p> <p>Upon such termination, the Engineer-in-charge shall determine the value of the work done and issue a Payment Certificate which shall include:</p> <ul style="list-style-type: none"> i the amounts payable for any acceptable work carried out for which a price is stated in the Contract; ii the Cost of Plant and Materials ordered for the Works which have been delivered to the Contractor, or of which the Contractor is liable to accept delivery: this Plant and Materials shall become the property of (and be at the risk of) the Procuring Entity when paid for by the Procuring Entity, and the Contractor shall place the same at the Procuring Entity's disposal; iii other Costs or liabilities which in the circumstances were reasonably and necessarily incurred by the Contractor in the expectation of completing the Works; iv the Cost of removal of Temporary Works and Contractor's Equipment from the Site.
Release from Performance	19.7	<p>Notwithstanding any other provision of this Clause, if any event or circumstance outside the control of the Parties (including, but not limited to, Force Majeure) arises which makes it impossible or unlawful for either or both Parties to fulfill its or their Contractual obligations or which, under the Law governing the Contract, entitles the Parties to be released from further performance of the Contract, then upon notice by either Party to the other Party of such event or circumstance:</p> <ul style="list-style-type: none"> i The Parties shall be discharged from further performance, without prejudice to the rights of either Party in respect of any previous breach of the Contract, and ii the sum payable by the Procuring Entity to the Contractor shall be the same as would have been

		payable under Sub-Clause 19.6 [Optional Termination, Payment and Release] if the Contract had been terminated under Sub-Clause 19.6.
20. Insurance		
General Requirements for Insurance	20.1	<p>In this Sub-Clause, “insuring Party” means, for each type of insurance, the Party responsible for effecting and maintaining the insurance specified in the relevant Sub-Clause.</p> <p>Wherever the Contractor is the insuring Party, each insurance shall be effected with insurers and in terms approved by the Procuring Entity. These terms shall be consistent with any terms agreed by both Parties before the date of the Letter of Acceptance. This agreement of terms shall take precedence over the provisions of this Sub-Clause.</p> <p>Wherever the Procuring Entity is the insuring Party, each insurance shall be effected with insurers and in terms acceptable to the Contractor. These terms shall be consistent with any terms agreed by both Parties before the date of the Letter of Acceptance. This agreement of terms shall take precedence over the provisions of this Sub-Clause.</p> <p>If a policy is required to indemnify joint insured, the cover shall apply separately to each insured as though a separate policy had been issued for each of the joint insured. If a policy indemnifies additional joint insured, namely in addition to the insured specified in this Sub-Clause, (i) the Contractor shall act under the policy on behalf of these additional joint insured except that the Procuring Entity shall act for Procuring Entity’s Personnel, (ii) additional joint insured shall not be entitled to receive payments directly from the insurer or to have any other direct dealings with the insurer, and (iii) the insuring Party shall require all additional joint insured to comply with the conditions stipulated in the policy.</p> <p>Each policy insuring against loss or damage shall provide for payments to be made in the currencies required to rectify the loss or damage. Payments received from insurers shall be used for the rectification of the loss or damage.</p> <p>The relevant insuring Party shall, within the respective periods stated in the Contract Data (calculated from the Commencement Date), submit to the other Party:</p> <ul style="list-style-type: none"> i evidence that the insurances described in this Sub-Clause have been effected, and ii copies of the policies for the insurances described in Sub-Clause 20.2 [Insurance for Works and Contractor’s Equipment] and Sub-Clause 20.3 [Insurance against Injury to Persons and Damage to Property].

		<p>When each premium is paid, the insuring Party shall submit evidence of payment to the other Party. Whenever evidence or policies are submitted, the insuring Party shall also give notice to the Engineer-in-charge.</p> <p>Each Party shall comply with the conditions stipulated in each of the insurance policies. The insuring Party shall keep the insurers informed of any relevant changes to the execution of the Works and ensure that insurance is maintained in accordance with this Sub-Clause.</p> <p>Neither Party shall make any material alteration to the terms of any insurance without the prior approval of the other Party. If an insurer makes (or attempts to make) any alteration, the Party first notified by the insurer shall promptly give notice to the other Party.</p> <p>If the insuring Party fails to effect and keep in force any of the insurances it is required to effect and maintain under the Contract, or fails to provide satisfactory evidence and copies of policies in accordance with this Sub-Clause, the other Party may (at its option and without prejudice to any other right or remedy) effect insurance for the relevant coverage and pay the premiums due. The insuring Party shall pay the amount of these premiums to the other Party, and the Contract Price shall be adjusted accordingly.</p> <p>Nothing in this Sub-Clause limits the obligations, liabilities or responsibilities of the Contractor or the Procuring Entity, under the other terms of the Contract or otherwise. Any amounts not insured or not recovered from the insurers shall be borne by the Contractor and/ or the Procuring Entity in accordance with these obligations, liabilities or responsibilities. However, if the insuring Party fails to effect and keep in force an insurance which is available and which it is required to effect and maintain under the Contract, and the other Party neither approves the omission nor effects insurance for the coverage relevant to this default, any moneys which should have been recoverable under this insurance shall be paid by the insuring Party.</p> <p>Payments by one Party to the other Party shall be subject to Sub-Clause 2.5 [Procuring Entity's Claims] or Sub-Clause 21.2 [Contractor's Claims], as applicable.</p>
<p>Insurance for Works and Contractor's Equipment</p>	<p>20.2</p>	<p>The insuring Party shall insure the Works, Plant, Materials and Contractor's Documents for not less than the full reinstatement Cost including the Costs of demolition, removal of debris and professional fees and profit. This insurance shall be effective from the date by which the evidence is to be submitted under Sub-Clause 20.1 [General Requirements for Insurances], until the date of issue of the Taking-Over Certificate for the Works.</p> <p>The insuring Party shall maintain this insurance to provide cover until the date of issue of the Performance Certificate, for loss or damage for which the Contractor is liable arising</p>

		<p>from a cause occurring prior to the issue of the Taking-Over Certificate, and for loss or damage caused by the Contractor in the course of any other operations including those under Clause 13 [Defect Liability].</p> <p>The insuring Party shall insure the Contractor's Equipment for not less than the full replacement value, including delivery to Site. For each item of Contractor's Equipment, the insurance shall be effective while it is being transported to the Site and until it is no longer required as Contractor's Equipment.</p> <p>Unless otherwise stated in the Special Conditions, insurances under this Sub-Clause:</p> <ul style="list-style-type: none"> i shall be effected and maintained by the Contractor as insuring Party, ii shall be in the joint names of the Parties, who shall be jointly entitled to receive payments from the insurers, payments being held or allocated to the Party actually bearing the Costs of rectifying the loss or damage, iii shall be extended to cover liability for all loss and damage from any cause not listed in Sub-Clause 18.3 [Procuring Entity's Risks], iv shall also cover, to the extent specifically required in the Contract Data, loss or damage to a part of the Works which is attributable to the use or occupation by the Procuring Entity of another part of the Works, and loss or damage from the risks listed in Sub-Clause 18.3 [Procuring Entity's Risks], excluding (in each case) risks which are not insurable at commercially reasonable terms, and v may however exclude loss of, damage to, and reinstatement of: <ul style="list-style-type: none"> (a) a part of the Works which is in a defective condition due to a defect in its design, materials or workmanship (but cover shall include any other parts which are lost or damaged as a direct result of this defective condition and not as described in sub- paragraph (b) below), (b) a part of the Works which is lost or damaged in order to reinstate any other part of the Works if this other part is in a defective condition due to a defect in its design, material or workmanship, and (c) A part of the Works which has been taken over by the Procuring Entity, except to the extent that the Contractor is liable for the loss or damage.
<p>Insurance against Injury to Persons and Damage to Property</p>	<p>20.3</p>	<p>The insuring Party shall insure against each Party's liability for any loss, damage, death or bodily injury which may occur to any physical property (except things insured under Sub-Clause 20.2 [Insurance for Works and Contractor's Equipment]) or to any person (except persons insured under Sub-Clause 20.4 [Insurance for Contractor's Personnel]), which may arise out of the Contractor's</p>

		<p>performance of the Contract and occurring before the issue of the Performance Certificate.</p> <p>This insurance shall be for a limit per occurrence of not less than the amount stated in the Contract Data with no limit on the number of occurrences.</p> <p>Unless otherwise stated in the Special Conditions, the insurances specified in this Sub-Clause:</p> <ul style="list-style-type: none"> i shall be effected and maintained by the Contractor as insuring Party, ii shall be in the joint names of the Parties, iii shall be extended to cover liability for all loss and damage to the Procuring Entity's property (except things insured under Sub-Clause 20.2 [Insurance for Works and Contractor's Equipment] arising out of the Contractor's performance of the Contract, and iv may however exclude liability to the extent that it arises from: <ul style="list-style-type: none"> (a) the Procuring Entity's right to have the Permanent Works executed on, over, under, in or through any land, and to occupy this land for the Permanent Works, (b) damage which is an unavoidable result of the Contractor's obligations to execute the Works and remedy any Defects, and (c) a cause listed in Sub-Clause 18.3 [Procuring Entity's Risks], except to the extent that cover is available at commercially reasonable terms.
Insurance for Contractor's Personnel	20.4	<p>The Contractor shall effect and maintain insurance against liability for claims, damages, losses and expenses (including legal fees and expenses) arising from injury, sickness, disease or death of any person employed by the Contractor or any other of the Contractor's Personnel.</p> <p>The insurance shall cover the Procuring Entity and the Engineer-in-charge against liability for claims, damages, losses and expenses (including legal fees and expenses) arising from injury, sickness, disease or death of any person employed by the Contractor or any other of the Contractor's Personnel, except that this insurance may exclude losses and claims to the extent that they arise from any act or neglect of the Procuring Entity or of the Procuring Entity's Personnel.</p> <p>The insurance shall be maintained in full force and effect during the whole time that these personnel are assisting in the execution of the Works. For a Subcontractor's employees, the insurance may be effected by the Subcontractor, but the Contractor shall be responsible for compliance with this Sub-Clause.</p>
21. Claims, disputes and Arbitration		
Recovery	21.1.1	Any amount inadvertently paid as not due to the Contractor shall be treated as acknowledged recovery/ or debt due

		from the Contractor. The Contractor shall immediately inform the Engineer-in-charge about such amount and offer to reimburse immediately to the Engineer-in-charge.
	21.1.2	Whenever any claim against the Contractor for the payment of a sum of money arises out of or under the Contract, the Procuring Entity shall be entitled to recover such a sum by appropriating, in part or whole of the Performance Security, or enlistment deposit of the Contractor. In the event of the Performance Security and enlistment deposit being insufficient or if no Performance Security has been taken, then the balance or the total sum recoverable, as the case may be, shall be deducted from any sum, then due or which at any time, thereafter, may become due to the Contractor, under this Contract or other Contracts with the Procuring Entity. Should these sums not be sufficient to cover the full amount recoverable, the balance remaining due shall be recovered from the Contractor as arrears of land revenue under Section 53 of the Act.
Contractor's Claims	21.2	<p>If the Contractor considers himself to be entitled to any extension of the Time for Completion and/ or any additional payment, under any Sub-Clause of these Conditions or otherwise in connection with the Contract, the Contractor shall give notice to the Engineer-in-charge, describing the event or circumstance giving rise to the claim. The notice shall be given as soon as practicable, but not later than 28 Days after the Contractor became aware, or should have become aware, of the event or circumstance.</p> <p>If the Contractor fails to give notice of a claim within such period of 28 Days, the Time for Completion shall not be extended, the Contractor shall not be entitled to additional payment, and the Procuring Entity shall be discharged from all liability in connection with the claim. Otherwise, the following provisions of this Sub-Clause shall apply.</p> <p>The Contractor shall also submit any other notices which are required by the Contract, and supporting particulars for the claim, all as relevant to such event or circumstance.</p> <p>The Contractor shall keep such contemporary records as may be necessary to substantiate any claim included in the claim, either on the Site or at another location acceptable to the Engineer-in-charge. Without admitting the Procuring Entity's liability, the Engineer-in-charge may, after receiving any notice under this Sub-Clause, monitor the record-keeping and/ or instruct the Contractor to keep further contemporary records. The Contractor shall permit the Engineer-in-charge to inspect all these records, and shall (if instructed) submit copies to the Engineer-in-charge.</p> <p>Within 42 Days after the Contractor became aware (or should have become aware) of the event or circumstance</p>

		<p>giving rise to the claim, or within such other period as may be proposed by the Contractor and approved by the Engineer-in-charge, the Contractor shall send to the Engineer-in-charge a fully detailed claim which includes full supporting particulars of the basis of the claim and of the extension of time and/or additional payment claimed. If the event or circumstance giving rise to the claim has a continuing effect:</p> <ol style="list-style-type: none"> i. this fully detailed claim shall be considered as interim; ii. the Contractor shall send further interim claims at monthly intervals, giving the accumulated delay and/or amount claimed, and such further particulars as the Engineer-in-charge may reasonably require; and iii. the Contractor shall send a final claim within 28 Days after the end of the effects resulting from the event or circumstance, or within such other period as may be proposed by the Contractor and approved by the Engineer-in-charge. <p>Within 42 Days after receiving a claim or any further particulars supporting a previous claim, or within such other period as may be proposed by the Engineer-in-charge and approved by the Contractor, the Engineer-in-charge shall respond with approval, or with disapproval and detailed comments. He may also request any necessary further particulars, but shall nevertheless give his response on the principles of the claim within the above defined time period.</p> <p>Within the above defined period of 42 Days, the Engineer-in-charge shall proceed in accordance with Sub-Clause 3.5 [Determinations] to agree or determine (i) the extension (if any) of the Time for Completion (before or after its expiry) in accordance with Sub-Clause 8.6 [Extension of Time for Completion], and/ or (ii) the additional payment (if any) to which the Contractor is entitled under the Contract.</p> <p>Each Payment Certificate shall include such additional payment for any claim as have been reasonably substantiated as due under the relevant provision of the Contract. Unless and until the particulars supplied are sufficient to substantiate the whole of the claim, the Contractor shall only be entitled to payment for such part of the claim as he has been able to substantiate.</p> <p>If the Engineer-in-charge does not respond within the timeframe defined in this Sub-Clause, the matter may be brought to the attention of the Procuring Entity by the Contractor within 15 days (beyond the initial period of 42 days) for timely intervention. If the Contractor is not satisfied with the decision of the Engineer-in-charge/ Procuring Entity, the Parties may refer the dispute to the Dispute Resolution Board in accordance with Sub-Clause 21.3 [Dispute Resolution].</p>
--	--	--

		The requirements of this Sub-Clause are in addition to those of any other Sub-Clause which may apply to a claim. If the Contractor fails to comply with this or another Sub-Clause in relation to any claim, any extension of time and/or additional payment shall take account of the extent (if any) to which the failure has prevented or prejudiced proper investigation of the claim, unless the claim is excluded under the second paragraph of this Sub-Clause.
Dispute Resolution	21.3.1	The procedure of reference of disputes to the Dispute Resolution Board and its functioning shall be as per Appendix B.
	21.3.2	The disputes which remain unresolved by the Dispute Resolution Board may be referred by either Party to Arbitration.

APPENDIX A

General Conditions for admissibility of Escalation

1. The exact percentage of labour/ material (excluding materials to be supplied by the Procuring Entity)/ bitumen/ diesel and petrol/ cement/ steel component for the Works shall be approved by the authority while sanctioning the detailed Estimates.
2. The breakup of components of labour/ materials (excluding materials to be supplied by the Procuring Entity)/ bitumen/ diesel and petrol/ cement/ steel as indicated in this Clause have been pre-determined as below:-

(a)	Labour -----	30 percent
(b)	Material -----	50 percent
(c)	Bitumen -----	01 percent
(d)	Diesel and Petrol -----	01 percent
(e)	Cement -----	12 percent
(f)	Steel -----	06 percent
	Total-----	100%]
3. While allowing price escalation the following shall be deducted from the value of Works done (R):
 - (a) Cost of material supplied by the Procuring Entity.
 - (b) Cost of services rendered for protection of the Works.
 - (c) Secured Advance/ any advance added earlier but deducted now after Works is measured.
 - (d) Cost of extra items, the rates for which have been worked out based on market rates/ mutually agreed rates.
4. The first statement of escalation shall be prepared at the end of three months in which the Works was awarded and the Works done from the date of start to the end of this period shall be taken into account. For subsequent statement, cost of Works done during every quarter shall be taken into account. At the completion of Works, the Works done during the last quarter or fraction, thereof, shall be taken into account.
5. For the purpose of reckoning the Works done during any period, the bills prepared during the period shall be considered. The dates of recording measurements in the Measurement Book by the Assistant Engineer shall be the guiding factor to decide the bills relevant to any period. The date of completion, as finally recorded by the competent authority in the Measurement Book, shall be the criterion.
6. The index relevant to any quarter, for which such compensation is paid, shall be the arithmetical average of the indices relevant of the calendar month.
7. Price adjustment Clause shall be applicable only for the Works that is carried out within the stipulated time, or extension thereof, as are not attributable to the Contractor.

8. If during the progress in respect of Contract Works stipulated to cost Rs.50 lacs or less, the value of Works actually done excluding cost of material supplied by the Procuring Entity, exceeds Rs. 50 lacs and completion period is more than 3 months, then escalation would be payable only in respect of value of Works in excess over Rs.50 lacs from the date of satisfying both the conditions.
9. Where originally stipulated period is 3 months or less but actual period of execution exceeds beyond 3 months on account of reasons not attributable to the Contractor, escalation amount would be payable only in respect of extended period if amount of Works is more than Rs.50 lacs.
10. In case the Contractor does not make prorata progress in the first or another time span and the short fall in progress is covered up by him during subsequent time span within original stipulated period then the price escalation of such Works expected to be done in the previous time span shall be notionally given based upon the price index of that quarter in which such Works was required to be done.
11. No claims for price adjustment other than those provided herein, shall be entertained.
12. If the period of completion including extended period attributable to the Procuring Entity exceeds three months but cost does not exceeds more than Rs.50 lacs, no escalation is admissible.
13. Similarly, if cost of Works increases more than Rs.50 lacs but completion period including extended period attributable to the Procuring Entity is less than 3 months, no escalation is admissible.
14. No provisional escalation is payable on the basis of indices of the previous quarter in absence of non publication of indices for concerned quarter by the RBI.
15. Escalation is always payable quarterly and no provisional escalation is payable monthly or fortnightly.
16. In case at the time of executing agreement, both the conditions (completion period 3 months and amount of Works Rs.50 lacs for admissibility of price escalation are not fulfilled and subsequent due to additional Works and extension of time attributable to Procuring Entity, both the conditions become fulfilled, in that case the escalation shall be payable from the date of satisfying both the conditions and only for Works done beyond Rs.50 lacs and in period of Works beyond 3 months.
17. The Contractor shall for the purpose of these conditions keep such books of account and other documents as are necessary to show the amount of any increase claimed or reduction available and shall allow inspection of the same by a duly authorised representative of the Government/ Procuring Entity and further shall at the request of the Engineer-in-charge furnish, verified in such a manner as the Engineer-in-charge may require any documents so kept and such other information as the Engineer-in-charge may require.
18. Price variation Clause shall be applicable in case of lump sum contracts estimated to cost more than Rs.100 crores with stipulated completion period of more than 18 months.

19. The component of operation and maintenance (O&M) cost included in the Contract Price shall not be subject to price variations. The price may be adjusted by the use of prescribed formula (or formulae) which breaks down the total price into components.
20. The amount of price variation in case of lump sum contracts will be made by adding or deducting, as the case may be, from the payments made at the stages of Works specified in the Contract document.

Appendix B

Dispute Resolution During Execution of the Contract

1.0 Dispute

Disputes are germane to any contract. A 'dispute' implies an assertion of a right or a claim by one party and repudiation thereof by the other party, either expressed or implied, and may be by words or by conduct. A mere 'difference' is not necessarily a dispute; when the parties fail to resolve it, the difference culminates in dispute.

1.1 Dispute Resolution in a Construction Contract

Since arbitrations are fairly time consuming, it is always advisable to sort out the disputes mutually through the mechanism of adjudication through Dispute Resolution Board (DRB), which is a sort of voluntary arbitration. Arbitration can be resorted to if the adjudication decision is not forthcoming or is not acceptable to any party. For dispute resolution following procedure will be followed:

2.0 Dispute Resolution Board (DRB)

- (a) A formal Sub-Clause of obtaining dispute resolution through DRB will be inserted in the Conditions of the Contract. A separate Dispute Resolution Agreement will also be drawn up, detailing therein provisions like: Eligibility of Members, date of commencement, manner of entry on the reference by the Members and their resignation; obligation of the Members, the Procuring Entity and the Contractor; terms of payment (monthly retainerhip fee, daily fee for travel & site visits, out-of-pocket expenses); manner of sharing the fees and expenses and of making payments; arrangements of site visits and their frequency; conduct of hearings; termination/phasing out the activities of DRB; default of the Member, and action to be taken in case of dispute in relation to DRB Agreement, etc.
- (b) DRB should be put in place within one month of Letter of Acceptance.
- (c) The DRB for all projects costing more than Rs 10 crore will comprise of three Members, one each to be appointed by the Procuring Entity and the Contractor and approved by the other. The third Member, who will also act as the presiding Member, will be selected by the first two Members and approved by the parties. If either of the first two Members is not so selected and approved, or the parties fail to reach an agreement on the third Member then on request of either or both parties, appointment will be made by concerned Administrative Department in case of Government Departments and Head of the Organisation (Chairman, etc.) concerned in other cases.
- (d) The Members to be appointed shall be out of a panel maintained by the Department/Organisation concerned and should be experienced in the type of construction actually involved and/ or finance and accounts and/ or contractual documents. **They should be persons of repute and integrity.**
- (e) If any dispute that arises at any stage between the Procuring Entity and the Contractor in connection with, or arising out of the Contract or the execution of the Works, including any disagreement by either party with any action, inaction, opinion,

instruction, determination, certificate or valuation of the Engineer, the matter in dispute shall, in the first place, should be tried to be settled amicably. If the dispute still remains unsettled, it shall be referred to the DRB.

- (f) Both parties shall promptly make available all information, access to the Site, and appropriate facilities, as the DRB may require for the purposes of making a recommendation on such dispute.
- (g) Within 56 days after receiving such reference, or within such other period as may be proposed by the DRB and approved by both parties, the DRB shall give its recommendation with reasons. The recommendation shall be binding on both parties, who shall promptly give effect to it unless and until it shall be revised in an amicable settlement or an arbitral award as described below. Unless the Contract has already been abandoned, repudiated or terminated, the Contractor shall continue to proceed with the Works in accordance with the Contract.
- (h) If either party is dissatisfied with the recommendation, then either party may, within 28 days after receiving the recommendation, or if the DRB fails to give its recommendation within 56 days (or as otherwise approved), within 28 days after the said period of 56 days has expired, give notice to the other party, with a copy to the Engineer-in-Charge, of its intention to commence arbitration proceedings.
- (i) If the DRB has given its decision within the stipulated period, and no notice of intention to commence arbitration as to such dispute has been given by either party within 28 days of the said decision, then the decision of DRB shall become final and binding.

3.0 Arbitration

- (a) Any dispute in respect of which the recommendations (if any) of DRB has not become final and binding, shall be finally settled by arbitration in accordance with the Indian' Arbitration and Conciliation Act, 1996, or any statutory amendment thereof.
- (b) The Arbitral Tribunal will comprise three Members, one each to be appointed by the Procuring Entity and the Contractor. The third Member, who will also act as the presiding Member, will be appointed by mutual consent of the first two Members. If the parties fail to reach an agreement on the third Member then on request of either or both parties, appointment will be made by concerned Administrative Department in case of Government Departments and Head of the Organisation (Chairman, etc.) concerned in other cases.
- (c) The Tribunal shall have full power to open up, review and revise any certificate, determination, instruction, opinion or valuation of the Engineer-in-Charge, and any decision of the DRB, relevant to the dispute.
- (d) Neither party shall be limited in the proceedings before the Tribunal to the evidence or arguments previously put before the DRB to obtain its decision, or to the reasons for dissatisfaction given in its notice of dissatisfaction.
- (e) Arbitration may be commenced prior to or after completion of the Works. The obligations of the Parties, the Engineer-in-Charge and the DRB shall not be altered by reason of any arbitration being conducted during the progress of the Works.

4.0 Language

All proceedings before DRB/ arbitral tribunal shall be in the Language of the Contract/ English.

5.0 Terms and conditions for engagement of DRB Member and Chairman

The terms and conditions including the remuneration and other facilities to be given to the Members of DRB and Arbitrators in case of civil engineering construction contracts/ consultancies shall be as notified by the State Government from time to time. Each Party to the Contract (the Contractor/ Consultant) shall be responsible for paying one-half of the remuneration. Since the fee structure has to be agreed by both the parties i.e. Procuring Entity and Contractor/ Consultant, the fee structure may also be got accepted by the respective Contractor/ Consultants. In the contracts the fee structure may be included as part of the bidding documents/ contract documents and the acceptance of the fee structure by the Contractors/ Consultants may be kept as a pre-condition for signing the Contract.

Section-VI-B : Special Conditions of the Contract/ Contract

Section VI B: Contract Data / Special Conditions of Contract

Ref. to GCC	Subject	Data
1.1	Procuring Entity's designation and address are:	THE CHIEF EXECUTIVE OFFICER Udaipur Smart City Limited. EMAIL: mc_udaipur@rediffmail.com
	The Works or Work is:	Development of Parking Lot under Smart City Mission, Udaipur
	The Site is:	Gulab Bagh, Near Bird Park, Udaipur
	Engineer-in-Charge's Designation and Address and communication details are:	Er. Arun Vyas, Superintending Engineer (SE), Udaipur Smart City Limited, Municipal Corporation of Udaipur, Town Hall, Udaipur – 313001, Rajasthan
	The Time for Completion and the Intended Completion Date are:	12 months
	Provisional sums/ Lump sums are:	Deleted
	The Department is:	Udaipur Smart City Limited
1.3	Communication:	Electronic transmission shall include e-mail, fax etc. and delivered shall include their transmission sent successfully to correct address.
1.4	The Language of the Contract is:	English
1.8.1	Signing of the Contract Agreement:	Within 15 Days of issue of notification of the award. Add following text; It is mandatory to register the JV under relevant Act after award of Letter of Acceptance but before signing of Contract Agreement within 30 days of issuance of Letter of Acceptance. Failure to register the JV in stipulated period may lead to forfeiture of bid security. The equity sharing as declared at the time of bidding shall be maintained while registering the JV before Contract execution. The minimum equities of all partners shall be maintained throughout the currency of contract. The Contract Agreement shall be executed with authorized representative of JV and all partners of JV.
1.14	Care and Supply of documents	Add: The Contractor shall maintain standard Site Order Books at the Site at all times during the execution of the Works for the use of the Procuring Entity's Representative and the Contractor. All instructions issued by the Procuring Entity's Representatives to the Contractor shall be recorded in duplicate in the Site Order Book and shall be signed by the issuer and countersigned by the Contractor. After compliance with the instruction the Contractor shall record the same in the

		Site Order Book duly signed and countersigned by the Procuring Entity's Representative. Acceptance of any part of the Works executed by the Contractor shall be subject to verification with respect to compliance of respective instructions of the Procuring Entity's Representative through the Site Order Book. The Procuring Entity's Representative shall retain the original copy of the site orders, while the Contractor shall retain the duplicate ones.
4.3.1	Performance Security	As per provision of ITB Performance Security amounting to total 10% of contract value shall be submitted / deducted as follows: (i) Contractor shall submit Performance Security @ 10% in advance at the time of signing of agreement in form of BG as per latest rules under RTPP act. The BG should be issued by any nationalized / schedule bank and shall remain valid up to 60 days beyond defect liability period. Bank Guarantee submitted against the performance guarantee, shall be unconditional and encashable/invokable at Udaipur when presented in specified Branch Office.
4.3.5	Refund of Performance Security	Replace GCC Clause 4.3.5 with the following: The Procuring Entity shall refund the Performance Security deposited as per clause 4.3.1 above, within 60 days of expiry of the Defect Liability Period, after satisfactory completion of all obligations under the Contract.
4.4	Commencement of the Works	The Works shall be commenced within a period of 7 Days from the date of signing of the Contract.
4.9.1	Third Party Quality Inspections as per ISO 17020 by a Departmental Authority or QCI approved/ accredited bodies:	Shall be conducted.
4.14	Avoidance of Interference with public conveniences	Add In case any operation connected with the works necessitates diversion, obstruction or closure of any road, railway, waterway or any other right of way, the approval of the Engineer-in-charge or the Engineer's Representative and the respective competent authorities shall be obtained well in advance by the Contractor. In case the Contractor's operations obstruct access to adjacent properties, the Contractor shall be responsible to provide reasonable temporary access to the affected parties. In case the Contractor fails to provide adequate temporary facilities, this shall be deemed to be an uncorrected Defect under the terms of Clause 13 and the Procuring Entity shall have the right to engage a third party to correct the Defect and the cost of such correction will be deducted from the Contract Price.

		The contractor will also be responsible to ensure completion of his work with utmost effort in earliest possible period to ensure minimum inconvenience to the public at large. If in the opinion of the Engineer in Charge, the work has not been done in time and the passage way not restored satisfactorily in time, he may after giving a notice of seven days have the work done through any other agency. He will in these circumstances enter the work done as work done by the contractor in measurement book and pay for the same to the contractor and also recover the actual cost paid by him for the work plus 5% of the value of this work from the payments or any other money due to the contractor.
4.18	Cost of water & electricity	Add: Charges for power connection for trial run and commissioning shall be borne by contractor
6.7	The normal working hours at the Site and Days of rest shall be:	9 AM to 5 PM as per relevant Labour Laws. However, when work is stopped, it should be ensured by the contractor that all safety measures have been taken to avoid any untoward incident during non-working hours.
7.3	Inspection	Add: The Contractor shall place order for the material and the equipment only after approval of the Engineer-in-charge. The Contractor shall submit the detailed design and drawings to the Engineer-in-charge for approval. The Contractor shall inform the Engineer-in-charge about the likely dates of testing and dispatching of the material. The Contractor shall notify the Engineer-in-charge for inspection and testing, at least seven (7) days prior to packing and shipping and shall supply the manufacturer's test results and quality control certificates. The inspection and test categories shall be applied prior to delivery of the equipment, of various categories as indicated in the technical specifications for each type of equipment. Category A: The drawing has to be approved by the Procuring Entity's Representative before manufacture and testing. The material has to be inspected by the Engineer-in-charge or an inspecting agency after approval of Procuring Entity's Representative at the manufacturer's premise before packing and dispatching. The inspection charges of the agency will be borne by the Procuring Entity but the contractor has to pay the inspection charges. The contractor will include in their next bill the inspection charges and the same will be reimbursed by the Procuring Entity from the provisional sum. The contractor shall provide the necessary equipment and facilities for tests and the cost thereof shall be borne by the Contractor. Category B: The drawings of the equipment have to be submitted and to be approved by the Engineer-in-charge prior to manufacture. The material has to be tested by the manufacturer and the manufacturer's test certificates are to be submitted and approved by the Engineer-in-charge before

		<p>dispatching of the equipment. Notwithstanding the above, the Engineer-in-charge, after examination of the test certificates, reserves the right to instruct the Contractor for retesting, if required, in the presence of the Contractor's representative.</p> <p>Category C: The material may be manufactured as per relevant standards and deliver to the site.</p> <p>For material / equipment under Category 'A' and 'B' the Engineer-in-charge will provide an\ authorization for packing and shipping after inspection.</p>
10.3	General Conditions for admissibility of Price Variation	In view of this, payment against price variation shall not be admissible for work of the Project
15.3	Schedule of Payments	<ul style="list-style-type: none"> • As per BoQ approved
20	Insurance	The details of Insurance covers to be obtained by the Contractor, including their value, terms and extent of coverage and other terms and conditions as applicable.

Section-VIC : Contract Forms

Section VI C: Contract Forms

Table of Contents

1. Letter of Acceptance
2. Contract Agreement
3. Performance Security
4. Performance Security Declaration
5. Contract Agreement Works

1. Letter of Acceptance

Letter of Acceptance

[on letterhead paper of the Procuring Entity]

No.

Dated

To: ***[name and address of the Contractor]***

Subject: ***[Notification of Award for the Works]***

This is to notify you that your Bid dated ***[date]*** for execution of the .
..... ***[name of the contract and identification number, as given
in the Contract Data]*** for the Accepted Contract Amount of the
equivalent of ***[.amount in numbers and words and name of
currency]***, as corrected and modified in negotiations and in
accordance with the Instructions to Bidders has been accepted by
[designation of the Procuring Entity] The date of
commencement and completion of the Works shall be:
.....

You are requested to furnish the Performance Security within Days in
the form given in the Contract Forms for the same for an amount equivalent to
Rupees within days of notification of the award valid up to 60
days after the date of expiry of Defects Liability Period and maintenance
period, if applicable, and sign the Contract, failing which action as stated in
sub-section 2 of section 42 of the Rajasthan Transparency in Public
Procurement Act, 2012 and Instructions to Bidders shall be taken.

Authorized Signature:

Name and Title of Signatory: Chief Executive Officer,

Udaipur Smart City Limited.

Designation:

2A. Contract Agreement (1) With Udaipur Smart City Limited

Contract Agreement

THIS AGREEMENT made theday of,, between the Governor of Rajasthan/ **[Udaipur Smart City Limited]**. (hereinafter “the Procuring Entity”) which expression shall, where the context so admits, be deemed to include his successors in office and assigns, of the one part, and **[name of the Contractor]**(hereinafter “the Contractor”), which expression shall, where the context so admits, be deemed to include his heirs, successors, executors and administrators, of the other part:

WHEREAS the *Procuring Entity* desires that the Works known as **[name of the Contract]**should be executed by the Contractor, and has accepted a Bid by the Contractor for the execution and completion of these Works and the remedying of any defects therein, and for which the Contractor has submitted Performance Security for Rupees ----- in the form of -----
------(For Udaipur Smart City Limited)

The Procuring Entity and the Contractor agree as follows:

1. In this Agreement words and expressions shall have the same meanings as are respectively assigned to them in the Contract documents referred to.
2. The following documents shall be deemed to form and be read and construed as part of this Agreement. This Agreement shall prevail over all other Contract documents.
 - a) the Letter of Acceptance;
 - b) the Bid of the Contractor as accepted along with the correspondence done on it, if any;
 - c) the Special Conditions of Contract/ Contract Data;
 - d) the General Conditions of Contract;
 - e) the Specifications;
 - f) the Drawings; and
 - g) the Instructions to Bidders and Notice Inviting Bids including Procurement Entity’s Requirement
3. In consideration of the payments to be made by the Procuring Entity to the Contractor as indicated in this Agreement, the Contractor hereby covenants with the Procuring Entity to execute the Works and to remedy defects therein (and, if applicable, maintain the Works for a period of -----) in conformity in all respects with the provisions of the Contract.

4. The Procuring Entity hereby covenants to pay the Contractor in consideration of the execution and completion of the Works and the remedying of defects therein (and, if applicable, maintain the Works for a period of -----), the Contract Price or such other sum as may become payable under the provisions of the Contract at the times and in the manner prescribed by the Contract.

IN WITNESS whereof the parties hereto have caused this Agreement to be executed in accordance with the laws of India and Rajasthan on the day, month and year indicated above.

Signed by

Signed by.....

for and on behalf of the Governor/ Palika Entity

.for and on behalf the Contractor

(Chief Executive Officer, Udaipur Smart City Limited)

in the presence of

in the presence of

Witness, Name, Signature, Address, Date

Witness, Name, Signature,
Address, Date

3A. Performance Security

Performance Security

..... *[Bank's Name, and Address of Issuing Branch or Office]*

Beneficiary: *[Name and Address of Procuring Entity (Chief Executive Officer, Udaipur Smart City Limited)]*

Date:

Performance Guarantee No.:

We have been informed that *[name of the Contractor]* (hereinafter called "the Contractor") has entered into Contract No. *[reference number of the Contract]*. . . . datedwith you, for the execution of*[name of contract and brief description of Works]* (hereinafter called "the Contract").

Furthermore, we understand that, according to the conditions of the Contract, a performance security is required.

At the request of the Contractor, we *[name of the Bank]* hereby irrevocably undertake to pay you any sum or sums not exceeding in total an amount of Rupees* *[amount in figures]* (Rupees..... . . . *[amount in words]*) **at the bank branch ____ located at Udaipur** such sum being payable upon receipt by us of your first demand in writing accompanied by a written statement stating that the Contractor is in breach of its obligation(s) under the Contract, without your needing to prove or to show grounds for your demand or the sum specified therein.

The Guarantor agrees to extend this guarantee for a specified period in response to the Procuring Entity's written request for such extension for that specified period, provided that such request is presented to the Guarantor before the expiry of the guarantee.

This guarantee shall expire, no later than the Day of , **, and any demand for payment under it must be received by us at this office on or before that date.

.....
Seal of Bank and Authorised Signature(s)

**** The Guarantor shall insert an amount representing the percentage of the Contract Price specified in the Contract***

***** Insert the date sixty days after the expected completion date, including defect liability period and maintenance period, if any.***

Notes: 1. All italicized text is for guidance on how to prepare this advance payment guarantee and shall be deleted from the final document.

2. The Procuring Entity should note that in the event of an extension of the time for completion of the Contract, the Procuring Entity would need to request an extension of this guarantee from the Guarantor. Such request must be in writing and must be made prior to the expiration date established in the guarantee.

Contract Agreement Works

THIS AGREEMENT made this .day of . 201., between Udaipur Smart City Limited, represented by the Chief Executive Officer Ph. 02974-2421255 E-mail: mc_udaipur@rediffmail.com(hereinafter “the Employer”), of the one part and M/S (herein after “the Contractor”), of the other part:

WHEREAS the *Employer* desires that the Works known as

and has accepted a Bid by the Contractor for the execution and completion of these Works and the remedying of any defects therein for one year under this contract in conformity with the provisions of the contract in all respect.

The Employer and the Contractor agree as follows:

1. In this Agreement words and expressions shall have the same meanings as are respectively assigned to them in the Contract documents referred to.
2. The following documents shall be deemed to form and be read and construed as part of this Agreement. This Agreement shall prevail over all other Contract documents.
 - a) Notice to Proceed
 - b) the Letter of Acceptance;
 - c) the Bid
 - d) the Addenda and Corrigendum
 - e) the Special Conditions
 - f) the General Conditions
 - g) the Specifications;
 - h) the Drawings;
 - i) Instructions to Bidders and Notice Inviting Bids including Procurement Entity’s Requirement
 - j) the Priced Bill of Quantities and
 - k) The Schedule of Supplementary information,
3. In consideration of the payments to be made by the Employer to the Contractor as indicated in this Agreement, the Contractor hereby covenants with the Employer to execute the Works and to remedy defects therein in conformity in all respects with the provisions of the Contract.
4. The Employer hereby covenants to pay the Contractor in consideration of the execution and completion of the Works and the remedying of defects therein, the Contract Price or such other sum as may become payable under the

provisions of the Contract at the times and in the manner prescribed by the Contract.

IN WITNESS whereof the parties hereto have caused this Agreement to be executed in accordance with the laws of India on the day, month and year indicated above.

Signed by

Signed by

Chief Executive Officer,
Udaipur Smart City Limited.
for and on behalf of the Employer

for and on behalf the Contractor

Witness, Name, Signature, Address

Witness, Name, Signature, Address