



UJJAIN SMART CITY LIMITED, UJJAIN

REQUEST FOR PROPOSAL

for

**SELECTION OF AGENCY FOR IMPLEMENTATION,
MANAGEMENT AND MAINTENANCE OF DIGITAL
CENTRE AS A SMART CLASSROOM DEMONSTRATION
PROJECT IN UJJAIN**

NIT No.39

RFP Publication Date: 06-February-2018

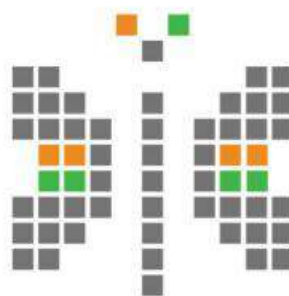

Smart City
MISSION TRANSFORM-NATION

NOTICE INVITING TENDER

NIT No: USCL/39 Date:06-February-2018

Ujjain Smart City Limited invites proposal from reputed organization for “RFP for Selection of Agency For Implementation, Management And Maintenance Of Digital Centre as a Smart Classroom Demonstration Project In Ujjain”. Interested firms may submit their proposals on e-procurement portal i.e. www.mpeproc.gov.in as per below mentioned details:

1.	Tender document Fee	<input type="checkbox"/> 1,000 (Rupees One Thousand Only) (through Online e-Tendering Payment Gateway only)
2.	Earnest Money Deposit	Earnest Money Deposit of Rs. 10,000 (Rupees Ten Thousand only)
3.	Last date to send in requests for clarifications on the tender	Pre-Bid Queries shall be sent to ujjainsmartcity@gmail.com as per format attached in <i>this RFP</i> before the pre-bid meeting date.
4.	Time, Date and Venue for Pre- Bid Conference	03:00PM, 20-February-2018 Ujjain Smart City Limited SimhasthaMelaOffice, Kothi Road, Ujjain (M.P.)
5.	Last date for Purchase of Tender	12-March-2018 up to 17:00
6.	Bid (Technical and Commercial) Submission End Date(Online)	12-March-2018 up to 17:30
7.	Technical Bid Submission End Date (Physical)	13-March-2018 up to 17:00 Ujjain Smart City Limited SimhasthaMela Office, Kothi Road, Ujjain (M.P.)
8.	Technical bids opening time, date and Venue	13-March-2018 after 17:30 Online
9.	Declaration of short-list of bidders for commercial bid	To Be Declared Later
10.	Declaration of Technically Qualified Bidders for opening of commercial bid	To Be Declared Later

Executive Director
Ujjain Smart City Limited

DISCLAIMER

The information contained in this Request for Proposals document (“RFP”) or subsequently provided to Applicants, whether verbally or in documentary or any other form by or on behalf of the Authority or any of its employees or advisers, is provided to Applicants on the terms and conditions set out in this RFP and such other terms and conditions subject to which such information is provided.

This RFP is not an agreement or an offer by the Authority to the prospective Applicants or any other person. The purpose of this RFP is to provide interested parties with information that may be useful to them in the formulation of their Proposals pursuant to this RFP. This RFP includes statements, which reflect various assumptions and assessments arrived at by the Authority in relation to the Consultancy. Such assumptions, assessments and statements do not purport to contain all the information that each Applicant may require. This RFP may not be appropriate for all persons, and it is not possible for the Authority, its employees or advisers to consider the objectives, technical expertise and particular needs of each party who reads or uses this RFP. The assumptions, assessments, statements and information contained in this RFP, may not be complete, accurate, adequate or correct. Each Applicant should, therefore, conduct its own investigations and analysis and should check the accuracy, adequacy, correctness, reliability and completeness of the assumptions, assessments and information contained in this RFP and obtain independent advice from appropriate sources.

Information provided in this RFP to the Applicants may be on a wide range of matters, some of which may depend upon interpretation of law. The information given is not intended to be an exhaustive account of statutory requirements and should not be regarded as a complete or authoritative statement of law. The Authority accepts no responsibility for the accuracy or otherwise for any interpretation or opinion on the law expressed herein.

The Authority, its employees and advisers make no representation or warranty and shall have no liability to any person including any Applicant under any law, statute, rules or regulations or tort, principles of restitution or unjust enrichment or otherwise for any loss, damages, cost or expense which may arise from or be incurred or suffered on account of anything contained in this RFP or otherwise, including the accuracy, adequacy, correctness, reliability or completeness of the RFP and any assessment, assumption, statement or information contained therein or deemed to form part of this RFP or arising in any way in this Selection Process.

The Authority also accepts no liability of any nature whether resulting from negligence or otherwise, howsoever caused, arising from reliance of any Applicant upon the statements contained in this RFP.

The Authority may in its absolute discretion, but without being under any obligation to do so, update, amend or supplement the information, assessment or assumption contained in this RFP.

The issue of this RFP does not imply that the Authority is bound to select an Applicant or to appoint the Selected Applicant, as the case may be, for the Consultancy and the Authority reserves the right to reject all or any of the Proposals without assigning any reasons whatsoever.

The Applicant shall bear all its costs associated with or relating to the preparation and submission of its Proposal including but not limited to preparation, copying, postage, delivery fees, expenses associated with any demonstrations or presentations which may be required by the Authority or any other costs incurred in connection with or relating to its Proposal. All such costs and expenses will remain with the Applicant and the Authority shall not be liable in any manner whatsoever for the same or for any other costs or other expenses incurred by an Applicant in preparation for submission of the Proposal, regardless of the conduct or outcome of the Selection Process.

TABLE OF CONTENTS

1	INTRODUCTION.....	6
1.1	BACKGROUND	6
1.2	REQUEST FOR PROPOSALS.....	6
1.3	DUE DILIGENCE BY APPLICANTS	6
1.4	SALE OF RFP DOCUMENT	6
1.5	VALIDITY OF THE PROPOSAL.....	6
1.6	BRIEF DESCRIPTION OF THE SELECTION PROCESS	7
1.7	SCHEDULE OF SELECTION PROCESS.....	7
1.8	PRE-PROPOSAL VISIT TO THE SITE AND INSPECTION OF DATA.....	7
1.9	PRE-PROPOSAL CONFERENCE	7
2	INSTRUCTION TO BIDDERS	8
2.1	ADVICE TO THE BIDDERS	8
2.2	PROCEDURE FOR SUBMISSION OF BIDS	8
2.3	CLARIFICATIONS IN RFP DOCUMENT	9
2.4	PRE BID MEETING	9
2.5	EXTENSION OF DEADLINE FOR SUBMISSION OF PROPOSALS.....	10
2.6	LATE SUBMISSION OF BID.....	10
2.7	EARNEST MONEY DEPOSIT (EMD)	10
2.8	CROSS CHECKING	10
2.9	ABSENCE OF SPECIFICATIONS	10
2.10	COST TO BID	10
2.11	LANGUAGE OF BIDS.....	10
2.12	DOCUMENTS COMPRISING THE BIDS	10
2.13	BID PRICES.....	11
2.14	FIRM PRICES.....	11
2.15	BIDDER QUALIFICATION	11
2.16	PERIOD OF VALIDITY OF BIDS	11
2.17	LOCAL / SITE CONDITIONS	11
2.18	MODIFICATION AND WITHDRAWAL OF BIDS.....	12
2.19	OPENING OF TECHNICAL BIDS.....	12
2.20	EVALUATION OF BIDS.....	12
2.20.1	<i>Preliminary Examination</i>	12
2.20.2	<i>Clarification</i>	12
2.20.3	<i>Evaluation of Bids</i>	12
2.20.4	<i>Eligibility Evaluation Criteria</i>	13
2.20.5	<i>Evaluation of Commercial Bids</i>	14
2.21	NEGOTIATIONS WITH THE SUCCESSFUL BIDDER	14
2.22	POST QUALIFICATION AND AWARD CRITERIA	14
2.23	RIGHT TO VARY SCOPE OF CONTRACT AT THE TIME OF AWARD.....	14
2.24	RIGHT TO ACCEPT ANY BID AND TO REJECT ANY OR ALL BIDS	15
2.25	NOTIFICATION OF AWARD - LETTER OF ACCEPTANCE	15
2.26	FORFEITURE OF EARNEST MONEY DEPOSIT.....	15
2.27	SIGNING OF CONTRACT.....	15
2.28	PERFORMANCE GUARANTEE	15
2.29	CONTRACT PERIOD	15
2.30	REJECTION CRITERIA	15
2.31	GENERAL REJECTION CRITERIA	15
2.32	TECHNICAL REJECTION CRITERIA	16
2.33	COMMERCIAL REJECTION CRITERIA.....	16
2.34	CONCESSIONS PERMISSIBLE UNDER STATUTES	16
2.35	INCOME TAX LIABILITY	16
2.36	INTELLECTUAL PROPERTY RIGHTS	16
3	SCOPE OF WORK AND TERMS OF REFERENCE	17

3.1	INTRODUCTION	17
3.2	PLANNING AND INSTALLATION	17
3.2.1	<i>System Planning and approvals from the client.....</i>	<i>17</i>
3.2.2	<i>Site Preparation</i>	<i>17</i>
3.2.3	<i>Installation Schedule</i>	<i>17</i>
3.2.4	<i>Technical Standards – Equipment & Interior.....</i>	<i>17</i>
3.2.5	<i>Human Resource Plan.....</i>	<i>17</i>
3.2.6	<i>Number of Devices</i>	<i>18</i>
3.2.7	<i>Hours of Operation</i>	<i>18</i>
3.2.8	<i>Data Transfer to client</i>	<i>18</i>
3.2.9	<i>User Information System</i>	<i>18</i>
3.2.10	<i>Data Reporting.....</i>	<i>18</i>
3.3	LEGAL.....	18
3.4	TECHNICAL & FUNCTIONAL SPECIFICATIONS	19
3.4.1	<i>Functional Requirements for Wireless Networking</i>	<i>19</i>
3.4.2	<i>Functional Requirements for Display Security Stand for Tablets.....</i>	<i>19</i>
3.4.3	<i>BOQ.....</i>	<i>19</i>
3.5	IMPLEMENTATION.....	20
3.5.1	<i>Contract Period.....</i>	<i>20</i>
3.5.2	<i>On Ground Testing.....</i>	<i>20</i>
3.5.3	<i>Maintenance.....</i>	<i>21</i>
3.6	DELIVERABLES	21
3.7	DELIVERABLES, TIMELINES & PAYMENT TERMS.....	21
3.8	SERVICE LEVEL BENCHMARKS	21
3.9	DAMAGES.....	22
3.10	SUMMARY OF RESPONSIBILITIES.....	22
3.10.1	<i>The Client.....</i>	<i>22</i>
3.10.2	<i>The Agency.....</i>	<i>22</i>
3.11	EXTENSION / VARIATION OF THE SYSTEM	22
3.12	NO ADDITIONAL FEES FROM USER FOR THE SERVICES.....	23
4	MODEL MASTER AGREEMENT.....	27
5	BID FORMS.....	51
5.1	INSTRUCTIONS TO BIDDERS FOR PREPARING THE BID FORMS	51
5.2	BID CHECKLIST	51
5.3	BID / PROPOSAL FORMS	52
5.4	FINANCIAL BID FORMS	62
6	MISCELLANEOUS	64
6.1	DEED OF INDEMNITY	64
6.2	NON-DISCLOSURE AGREEMENT	65
6.3	FORMAT FOR PERFORMANCE BANK GUARANTEE	69
6.4	FORMAT FOR EARNEST MONEY DEPOSIT GUARANTEE	72

1 Introduction

1.1 Background

Ujjain city has been selected in round-2 of smart cities challenge to implement the Smart Cities Mission (SCM). Ujjain Smart City Proposal (SCP) has secured third rank in second round cities. The area based development (ABD) proposal spreads across a total area of 1023 acres in Mahakal region, having a population of 87,766 which is almost 17% of the total population of Ujjain city. An area of about 756.7 acres is proposed to be retrofitted with smart features/infrastructure and 266.25 acres is proposed to be redeveloped with zonal/layout/building level smart features/infrastructure in accordance with SCP and SCM guidelines.

The pan-city proposal includes Ujjain City Management & Information Dissemination (UMID) System. UMID is a comprehensive ICT (Information Communication Technology) based system, which will incorporate smart and efficient management modules for traffic, waste, safety & security in initial phase. It will integrate existing deployed ICT modules & will aggregates all future ICT-enabled interventions to be implemented in a phased manner.

As per the SCP, the estimated project cost for smart city projects is about Rs. 2318.1 crores (could be more or less during planning, design and implementation phase). The estimated project cost of ABD component and pan-city component is about Rs. 1868.9 crores and Rs 307.2 crores respectively; Rs 142 Cr for A&OE (Administrative and Office Expense) and Interest during construction period. The Applicants are advised to carry out their own due diligence including but not limited to review of smart city proposal and field investigations.

For the purpose of implementing the Smart Cities project, Ujjain Smart City Limited (USCL) (the “Authority”), a Special Purpose Vehicle (SPV) for Ujjain Smart City Projects has been incorporated as a company under the Companies Act, 2013. USCL would receive funds from Government of India and Government of Madhya Pradesh (GoMP) for the development of Ujjain as smart city. USCL intends to apply part of this fund for the said services as specified in this document.

1.2 Request for Proposals

The Authority invites proposals (the “Proposals”) for Selection of RFP for Selection of Agency for Implementation, Management and Maintenance of Digital Centre in Ujjain.

The Authority intends to select the Agency through an open competitive bidding process in accordance with the procedure set out herein.

1.3 Due diligence by Applicants

Applicants are encouraged to inform themselves fully about the assignment and the local conditions before submitting the Proposal by paying a visit to the Authority and the Project site, sending written queries to the Authority, and attending a Pre-Proposal Conference on the date and time specified.

1.4 Sale of RFP Document

RFP document can be downloaded from the website of www.mpeproc.gov.in. However, the bids of only those Applicant shall be considered for evaluation who have made online payment of the specified amount for the RFP document plus service & gateway charges, without the copy of acknowledgement of payment bids will not be accepted. The RFP Fee is to be paid by the bidder by making online payment only against this RFP.

1.5 Validity of the Proposal

The Proposal shall be valid for a period of not less than 180 days from the Proposal Due Date.

1.6 Brief description of the Selection Process

The Authority will adopt a two stage selection process (collectively the “**Selection Process**”) for evaluating the Proposals comprising of technical bids and financial bids to be submitted by the Applicant. For avoidance of doubt, the technical proposal shall be submitted in hard copy to the Authority Address and in soft copy online through e-procurement portal and the financial proposal shall be submitted only online through e-procurement. The selection will be done through Least Cost (L1) Selection process.

In the first stage, an Eligibility and technical evaluation will be carried out. Based on this technical evaluation, a list of short-listed applicants shall be prepared. In the second stage, a financial evaluation will be carried out. The Applicant securing the lowest cost (the “**Selected Applicant**”) shall be called for negotiation, if necessary, while the second ranked Applicant will be kept in reserve.

1.7 Schedule of Selection Process

The Authority would endeavour to adhere to the schedule as laid out in this document.

1.8 Pre-Proposal visit to the Site and inspection of data

Prospective Applicants may visit the Site and review the available data at any time prior to the proposal submission date. For this purpose, they will provide at least two days’ notice to the nodal officer.

1.9 Pre-Proposal Conference

The date, time and venue of Pre-Proposal Conference shall be:

Date and Time: As mentioned in this document.

Venue: As mentioned in this document.

All communications including the submission of Proposal should be addressed to:

Executive Director,
Ujjain Smart City Limited
Address: Mela Office, Kothi Road, Ujjain,
Pin: 456010
Email: ujjainsmartcity@gmail.com

The **Official Website** of the Authority is: <http://www.mpeproc.gov.in>

All communications, including the envelopes, should contain the following information, to be marked at the top in bold letters:

RFP NOTICE NO. (as per brief NIT) –RFP TITLE.

2 Instruction to Bidders

2.1 Advice to the bidders

Bidders are advised to study this RFP document carefully before participating. It shall be deemed that submission of Bid by the bidder has been done after their careful study and examination of the RFP document with full understanding to its implications. The Bidder should sign and affix seal of the entity in each page of this RFP and submit along with the Eligibility Bid. In case of e-filing of the tender, a copy of the RFP should be uploaded and that shall be considered digitally signed and accepted by the Bidder.

2.2 Procedure for Submission of Bids

Complete bidding process will be online (e-Tendering) in two covers system. Submission of bids shall be in accordance to the instructions given in the Table below:

Particulars	Instructions
Cover 1	<p>Proof of submission of RFP Document Fee and Scanned copy of EMD</p> <p>The Proposal shall be prepared in accordance with the requirements specified in this RFP and the formats are prescribed in this RFP</p> <p>Proposal should be submitted through online bid submission process and also in Hard Copy as per mentioned in the NIT.</p>
Cover 2: Commercial Proposal	<p>The Commercial Proposal shall be prepared in accordance with the requirements specified in this RFP and in the formats prescribed in this RFP.</p> <p>Commercial Proposal should be submitted through online bid submission process only.</p>

USCL will conduct the bid evaluation based on documents submitted through online e-tendering portal.

The following points shall be considered for submission of bids:

- USCL shall not accept delivery of Bids in any manner other than that specified in this RFP. Bid delivered in any other manner shall be treated as defective, invalid and rejected.
- The Bidder is expected to price all the items and services sought in the RFP and proposed in the technical proposal. The Bid should be comprehensive and inclusive of all the services to be provided by the Bidder as per the scope of work and in accordance with the terms and conditions as set out in the Contract.
- USCL may seek clarifications from the Bidder on the technical proposal. Any of the clarifications by the Bidder on the technical proposal should not have any commercial implications. The Commercial Proposal submitted by the Bidder should be inclusive of all the items in the technical proposal and should incorporate all the clarifications provided by the Bidder on the technical proposal during the evaluation of the technical offer.
- Technical Proposal shall not contain any commercial information.
- If any Bidder does not qualify the Eligibility criteria stated in this RFP, the technical and commercial proposals of the Bidder shall not be opened. Similarly, if the Bidder does not meet the technical evaluation criteria, the commercial proposal of the Bidder shall be unopened in the e-Tendering system.
- It is required that the all the proposals submitted in response to this RFP should be unconditional in all respects, failing which USCL reserves the right to reject the proposal.

The tender should be a complete document and should be bound as a volume, bearing signature of the bidder and seal of the entity in each page of the document. The document should be serially page numbered and must contain the list of contents with page numbers.

Bidder must ensure that the information furnished by him online is identical to that submitted by them in the original paper bid document. In case of major differences between the hard copy and the soft copy, the tender is liable to be rejected.

The bid shall be typed in indelible ink and shall be signed by the Bidder or a person or persons duly authorized to bind the Bidder to the Contract. All pages of the bid, except for un-amended printed literature, shall be signed and stamped by the person or persons signing the bid.

The bid shall contain no interlineations, erasures or overwriting except as necessary to correct errors made by the Bidder, in which case such corrections shall be authenticated by the person or persons signing the bid. The Bidder shall duly sign and seal its bid with the exact name of the firm/company to whom the contract is to be issued.

Hard copies of the Bids submitted by hand should reach not later than the specified date and time in *NIT* of this RFP.

Telefax / Xerox / Photocopy bids will not be considered.

2.3 Clarifications in RFP Document

A prospective Bidder requiring any clarification on the Bidder Document may submit his queries, in writing, at the USCL address (E-Mail / Physical Mail) and as per schedule indicated in *NIT* of this RFP. The queries must be submitted only in the format mentioned to be considered for clarification.

2.4 Pre Bid Meeting

USCL shall hold a Pre-Bid Meeting scheduled as per *NIT* of this RFP. In this Pre-Bid Meeting, USCL would address the clarifications sought by the prospective bidders with regard to the RFP document and the project. The bidders would be required to submit their queries to USCL by e-mail on or before schedule specified in as per *NIT* of this RFP.

Bidders who have downloaded the RFP document are invited to attend the Pre-Bid Meeting even they do not have any specific queries. These bidders would be required to register for the Pre-Bid Meeting at USCL.

The minutes of the Pre-Bid Meeting may be circulated to all the participants of the meeting who choose to share their e-mail addresses and also will be posted at the website. No extension to any deadline referred to in this document will be granted on the basis or grounds that USCL should respond to any queries to provide any clarification.

The clarification offered at the Pre-Bid meeting will be recorded and the corrigendum/addendum issued will form part of the tender document.

Pre-Bid Queries – Tender No – Tender Name:					
Bidder Name (Organization) and Address				Mobile No.	
Representative Name				e-mail ID	
S. No.	Page No.	Section No.	Clause No.	Actual Clause in the RFP	Clarification Sought / Amendment Requested
1.					
2.					

The queries should also be submitted in an Excel / CSV file with one row containing exactly one query / suggestion complete in all respects, to the e-mail address provided. Bidders are requested to ensure that no sensitive information is transmitted to the Authority through the pre-bid queries and that the Authority may publish any or all of the queries received, in any format that they may decide.

The queries not adhering to the above mentioned format may not be responded to. USCL will respond to any request for clarification to queries on the Tender Document, received not later than the dates prescribed in *NIT* of this RFP. Bidders are requested not to communicate any sensitive information in the pre-bid queries as copies of the clarifications (including the query but without identifying the source of inquiry) will be sent to all prospective Bidders who have purchased the Tender Documents and will be uploaded in the website.

2.5 Extension of Deadline for submission of Proposals

Proposals must be received by the USCL at the address specified in the RFP not later than scheduled date and time. USCL may, in exceptional circumstances and at its discretion, extend the deadline for submission of Proposals by issuing a Corrigendum.

2.6 Late Submission of Bid

Any Bid received by the USCL after the deadline for submission of Proposals prescribed in RFP or Corrigendum will be returned unopened to the respective Bidder and the online bid shall not be accepted.

2.7 Earnest Money Deposit (EMD)

All bids must be accompanied by an EMD of the requisite value and in the requisite form.

The earnest money for the bidders will be refunded against a proper receipt within one month after signing of contract agreement between USCL and the successful bidder.

2.8 Cross checking

USCL reserves the right to contact and verify bidder's information, references and data submitted in the bid proposal without further reference to the bidder.

2.9 Absence of specifications

The absence of specifications details regarding any equipment to be supplied under this RFP implies that best general practices will prevail and that first quality material and workmanship will be applied as per the discretion of USCL. Certification standards, wherever available, for the to-be-installed equipment and materials, will prevail.

2.10 Cost to Bid

The Bidder shall bear all costs associated with the preparation and submission of its bid, including cost of presentation for the purposes of clarification of the bid, if so desired by the USCL. The USCL will in no case be responsible or liable for those costs, regardless of the conduct or outcome of the Tendering process.

2.11 Language of Bids

The Bids prepared by the Bidder and all correspondence and documents relating to the bids exchanged by the Bidder and USCL, shall be written in English language, provided that any printed literature furnished by the Bidder may be written in another language so long the same is accompanied by an English translation in which case, for purposes of interpretation of the bid, the English translation shall govern.

2.12 Documents Comprising the Bids

The bid prepared by the Bidder shall comprise of the following components as pre the formats specified.

A. Eligibility and Technical Bid

B. Commercial Bid

2.13 Bid Prices

The Bidder shall indicate in the Pro-forma prescribed, the unit rates and total Bid Prices of the equipment / services, it proposes to provide under the Contract. Prices should be shown separately for each item as detailed in Tender Documents. In absence of above information as requested, a bid may be considered incomplete and be summarily rejected.

The Bidder shall prepare the bid based on details provided in the tender documents. It must be clearly understood that the Scope of Work is intended to give the Bidder an idea about the order and magnitude of the work and is not in any way exhaustive and guaranteed by USCL. The Bidder shall carry out all the tasks in accordance with the requirement of the tender documents & due diligence and it shall be the responsibility of the Bidder to fully meet all the requirements of the tender documents. If during the course of execution of the project any revisions to the work requirements like Technical specifications, Equipment sizing etc. is to be made to meet the goals of project. All such changes shall be carried out within the current price without any impact to USCL.

2.14 Firm Prices

Prices quoted in the bid must be firm and final and shall not be subject to any upward modifications, on any account whatsoever. However, USCL reserves the right to negotiate the prices quoted in the bid to effect downward modification. The Bid Prices shall be indicated in Indian Rupees (INR) only.

The Commercial bid should clearly indicate the price to be charged without any qualifications whatsoever and should include all taxes, duties, fees, levies, works contract tax and other charges as may be applicable in relation to the activities proposed to be carried out.

2.15 Bidder Qualification

A Bidder can apply for this RFP on its own.

The "Bidder" as used in the tender documents shall mean the one who has signed the Tender Form. The Bidder may be either the Principal Officer or his duly Authorized Representative, in either cases they shall submit a certificate of authority. All certificates and documents (including any clarifications sought and any subsequent correspondences) received hereby, shall be furnished and signed by the representative and the principal.

It is further clarified that the individual signing the tender or other documents in connection with the tender must certify whether he/she signs as the Constituted attorney of the firm, or a company. The authorization shall be indicated by written power-of-attorney accompanying the bid. The power or authorization and any other document consisting of adequate proof of the ability of the signatory to bind the Bidder shall be annexed to the bid.

Any change in the Principal Officer shall be intimated to USCL in advance.

2.16 Period of Validity of Bids

Bids shall remain valid for 180 days from the date of opening of Bids prescribed by USCL. A bid valid for a shorter period may be rejected as non-responsive.

USCL may request the Bidder(s) for an extension of the period of validity for completion of evaluation. The request and the responses thereto shall be made in writing. The validity of EMD shall also may be requested to be suitably extended subject to Act and Rules framed by the Government of India and the Government of Madhya Pradesh.

2.17 Local / Site Conditions

It will be incumbent upon each Bidder to fully acquaint himself with the local conditions and other relevant factors at the proposed USCL sites which would have any effect on the performance of the contract and / or the

cost. The Bidders are advised to visit the proposed locations (at its own cost) and due-diligence should be conducted before the pre-bid meeting/ bid-submission.

The Bidder is expected to make a site visit to the proposed sites to obtain for himself on his own responsibility all information that may be necessary for preparing the bid and entering into contract. Obtaining such information shall be at Bidder's own cost.

Failure to obtain the information necessary for preparing the bid and/or failure to perform activities that may be necessary for the providing services before entering into contract will in no way relieve the successful Bidder from performing any work in accordance with the Tender documents.

It will be imperative for each Bidder to fully inform themselves of all legal conditions and factors which may have any effect on the execution of the contract as described in the bidding documents. The USCL shall not entertain any request for clarification from the Bidder regarding such conditions.

It is the responsibility of the Bidder that such factors have properly been investigated and considered while submitting the bid proposals and that no claim whatsoever including those for financial adjustment to the contract awarded under the bidding documents will be entertained by USCL and that neither any change in the time schedule of the contract nor any financial adjustments arising thereof shall be permitted by USCL on account of failure of the Bidder to appraise themselves of local laws and site conditions.

2.18 Modification and Withdrawal of Bids

No bidder shall be allowed to withdraw or modify the bids after submitting the bid.

2.19 Opening of Technical Bids

USCL will open the hard copies of the Technical Bid, in the presence of one authorized representative of the Bidder who chooses to attend, at the time, date and place, as mentioned in *NIT* of this RFP. Opening of tenders in the online portal shall be done on or after the time mentioned in the NIT.

2.20 Evaluation of Bids

The evaluation process of the tender proposed to be adopted by the USCL is indicated under this clause. The purpose of this clause is only to provide the Bidders an idea of the evaluation process that the USCL may adopt. However, the USCL reserves the right to modify the evaluation process at any time during the Tender process, without assigning any reason, whatsoever.

2.20.1 Preliminary Examination

The USCL will examine the bids to determine whether they are complete, whether the bid format confirms to the Tender requirements, whether required EMD has been furnished, whether the documents have been properly signed, and whether the bids are generally in order.

A bid determined as not substantially responsive will be rejected by the USCL and may not subsequently be made responsive by the Bidder by correction of the nonconformity.

2.20.2 Clarification

When deemed necessary, during the tendering process, the USCL may seek clarifications or ask the Bidders to make Technical presentations on any aspect from any or all the Bidders. However, that would not entitle the Bidder to change or cause any change in the substance of the tender submitted or price quoted.

2.20.3 Evaluation of Bids

The commercial bids of the qualified bidders as specified above will then be opened and reviewed to determine whether the commercial bids are substantially responsive in respect of commercial considerations. The evaluation will be made on the basis of Least Cost or L1, the bidder with the lowest cost would be declared successful.

Additional information/clarification – USCL reserves the right to ask for any additional information, as it may deem necessary to evaluate the bid proposal. Bidders that fail to submit additional information or clarification as sought by evaluation committee within 7 days of date of letter requesting for such additional information and/or clarification from USCL, their bids will be evaluated based on the information furnished along with the bid proposal.

2.20.4 Eligibility Evaluation Criteria

The bidder must possess the requisite experience, strength and capabilities in providing the services necessary to meet the requirements, as described in the tender document. The bidder must also possess the technical know-how and the financial wherewithal that would be required to successfully provide the services sought by the USCL for the entire period of the contract. The bids must be complete in all respect and should cover the entire scope of work as stipulated in the Tender document else the bids shall be summarily rejected.

The invitation to bid is open to all bidders who qualify the eligibility / Eligibility criteria as given below:

Sr. No.	Criteria	Specific Requirements	Documents Required
1.	Legal Entity	The Bidder should be entity registered under an appropriate act of parliament or laws of state legislature in India.	A valid copy of “Certificate of Registration” from Government Authorities including “name change certificate” (if any).
2.	GST Registration	The Bidder should hold valid GST Registration	Copy of the GST Registration Certificate.
3.	Turnover	The Bidder should have an annual Turnover of \square 10 Lacs in the last audited financial year.	Certificate from the Statutory Auditor / CA.
4.	Experience	The Bidder should have experience of Implementing or Supply of Mobile Devices/Tablets/iPads, Networking, Interior, (a similar type of works) etc. for an amount of Rs. 10 Lacs in ONE contract during the last three years. OR The Bidder should have experience of Implementing or Supply of Mobile Devices / Tablets / iPads, Networking, Interior, (a similar type of works) etc. for an amount of Rs. 6 Lacs in TWO contract during the last three years. OR The Bidder should have experience of Implementing or Supply of Mobile Devices / Tablets / iPads, Networking, Interior, (a similar type of works) etc. for an amount of Rs. 5 Lacs in THREE contract during the last three years.	Copy of Contract / Work Order / Completion Certificate (if project is completed) or Certificate from CA / CS for the project
5.	Blacklisting	The Bidder should not have been blacklisted by Central/State Government/PSU entity in India for unsatisfactory past performance, corrupt, fraudulent or any other unethical business practices as on date of submission of the proposal.	Undertaking by the authorized signatory. (as part of the cover letter)
6.	Project Co-	The Bidder is required to submit the CV of at least one Project Co-ordinator, who shall be deployed full time	CV's to be submitted in the

Sr. No.	Criteria	Specific Requirements	Documents Required
	ordinator	on the assignment as per the requirements of the RFP.	required format.

Bidders are required to meet ALL OF THE ELIGIBILITY CRITERIA and submit necessary proofs regarding the same.

Bidders are required to provided information and submit documents for all criteria where previous experience isaskedfor technical Evaluation. The qualified Bidders alone will be informed of the date of opening of the Commercial Bid. The Commercial Bids of technically qualified Bidders will alone be opened and evaluated. The decision of USCL will be final in this regard.

2.20.5 Evaluation of Commercial Bids

The Commercial Bid evaluation will be carried out as stated below:

- Commercial Proposals for the technically qualified bidders will be opened on the notified date and time and reviewed to determine whether the commercial proposals are substantially responsive. Bids that are not substantially responsive are liable to be disqualified at USCL's discretion and shall be intimated before the opening of the commercial bids.
- Total Cost of Bid (TCB) shall be calculated based on the commercial format given in the RFP.
- If there is a discrepancy between words and figures, the amount in words shall prevail. For any other calculation/ summation error etc. the bid may be liable to be rejected.

2.21 Negotiations with the successful Bidder

As per the evaluation criteria specified above in this Tender Document, selection of the Successful Bidder will be made and such Bidder will be called for negotiations for improvement of scope of work and commercial terms. USCL reserves the right to negotiate with the Bidder.

While negotiating the following aspects are to be considered:

- To improve the Service Level Agreement (SLA) and the Quality of Services (QoS)
- Further reduction in the offer submitted
- Advancing the commissioning schedule
- To improve the quantity
- Scope of training offered
- Others as may be brought out to the notice of USCL

2.22 Post Qualification and Award Criteria

An affirmative determination will be a prerequisite for award of the Contract to the Bidder. A negative determination will result in rejection of the Bidder's bid, in which event; the USCL will proceed to the next best evaluated bid to make a similar determination of that Bidder's capabilities to perform satisfactorily.

The Contract will be awarded to the successful bidder with the **LOWEST (L1) VALUE OF COMMERCIAL BID.**

2.23 Right to Vary Scope of Contract at the time of Award

The USCL may at any time, by a written order given to the Bidder, make changes to the scope of the Contract as specified on mutually agreeable basis.

If any such change causes an increase or decrease in the cost of, or the time required for the Bidder's performance of any part of the work under the Contract, whether changed or not changed by the order, an equitable adjustment shall be made in the Contract Value or time schedule, or both, and the Contract shall accordingly be amended. Any claims by the Bidder for adjustment under this Clause must be asserted within thirty (30) days from the date of the Bidder's receipt of the USCL changed order.

2.24 Right to Accept Any Bid and to Reject Any or All Bids

The USCL reserves the right to accept any bid, and to annul the Tender process and reject all bids at any time prior to award of Contract, without thereby incurring any liability to the affected Bidders or any obligation to inform the affected Bidders of the grounds for the USCL action.

The USCL reserves the right to negotiate the commercials with the selected Bidder.

2.25 Notification of Award - Letter of Acceptance

Prior to the expiration of the period of bid validity, the USCL will notify the successful Bidder in writing by sending a Letter of Acceptance (LOA) using registered letter or by fax/e-mail, to be confirmed in writing by registered letter, that its bid has been accepted.

The Implementation Schedule will commence from the date of issue of LOA. The notification of award will constitute the formation of the Contract.

2.26 Forfeiture of Earnest Money Deposit

If the Successful Bidder fails to act according to the tender conditions or backs out after his tender has been accepted, his Earnest Money Deposit will be forfeited to USCL.

2.27 Signing of Contract

At the same time as the USCL notifies the successful Bidder that its bid has been accepted, the USCL will send the Bidder the Pro-forma for Contract provided in the Tender Document, incorporating all agreements between the parties.

Within 7 days of receipt of the Contract, the successful Bidder shall sign and date the Contract and return it to the USCL. If the same is not executed within seven working days, the Earnest Money Deposit (EMD) of the Bidder may be forfeited and their tender may be held as non – responsive and liable for rejection as per the discretion of USCL.

2.28 Performance Guarantee

Within 15 days of the receipt of LOA from the USCL, the successful Bidder shall furnish the performance security in accordance with the Terms & Conditions of Contract, in the form of Bank Guarantee of 10% of the total contract value in prescribed format.

Failure of the successful Bidder to comply with the requirement of this Clause shall constitute sufficient grounds for the annulment of the award and forfeiture of the EMD.

2.29 Contract Period

The Contract will be initially valid for a period of 1 Year excluding implementation time.

2.30 Rejection Criteria

The right of final acceptance of the tender is entirely vested with the USCL who reserves the right to accept or reject any or all of the tenders in full or in parts without assigning any reason whatsoever. After acceptance of the tender by USCL, the Bidder should have no right to withdraw his tender, or claim higher price. The tender approving authority may also reject all the tenders for reasons such as change in scope of work, new technologies, and lack of anticipated financial resources, court orders, accidents or calamities and other unforeseen circumstances.

2.31 General Rejection Criteria

- Bids submitted without EMD or with inadequate EMD
- Conditional Bids

- If the information provided by the Bidder is found to be incorrect / misleading at any stage / time during the Tendering Process
- Any effort on the part of a Bidder to influence the bid evaluation, bid comparison or contract award decisions
- Bids received by the USCL, after the last date prescribed for receipt of bids.
- Bids without signature of person (s) duly authorized on crucial documents of the bids. Crucial documents will include the Letters, Certificates, Declarations, etc. The determination whether the document is crucial or not shall be performed by the USCL.
- Bids without power of authorization and any other document consisting of adequate proof of the ability of the signatory to bind the Bidder.

2.32 Technical Rejection Criteria

- Technical Bid containing commercial bid details.
- Revelation of Prices in any form or by any reason before opening the Commercial Bid
- Failure to furnish all information required by the Tender Document or submission of a bid not substantially responsive to the Tender Document in every respect.
- Bidders not quoting for the complete scope of Work as indicated in the Tender documents, addendum (if any) and any subsequent information given to the Bidder.
- Bidders not complying with the Technical and General Terms and conditions as stated in the Tender Documents.
- The Bidder not confirming unconditional acceptance of full responsibility of providing services in accordance with the Scope of work and Service Level Agreements of this tender.
- If the bid does not confirm to the timelines indicated in the bid.

2.33 Commercial Rejection Criteria

- Incomplete Commercial Bid.
- Commercial Bids that do not confirm to the Tender's Commercial Bid format.

2.34 Concessions permissible under statutes

Bidder, while quoting against this tender, must take cognizance of all concessions permissible under the statutes, failing which it will have to bear extra cost where Bidder does not avail concessional rates of levies like customs duty, excise duty, sales tax, etc. USCL will not take responsibility towards this. However, USCL may provide necessary assistance, wherever possible, in this regard.

2.35 Income tax liability

The bidder will have to bear all Income Tax liability both corporate, service and personal tax.

2.36 Intellectual Property Rights

The bidder/Implementing Agency shall identify USCL against all third party claims of infringement of patent, copyright, trademark and trade designs arising from use of the goods or any part thereof in India.

The Bidder shall indemnify the USCL against all third-party claims of infringement of patent, trademark or industrial design and intellectual property rights arising from the use of the Goods or any part thereof.

3 Scope of Work and Terms of Reference

3.1 Introduction

Ujjain Smart City Limited intends to setup a Digital Centre for the citizens of Ujjain, where people may visit and have access to digital media on various types of digital devices. Traditionally libraries used to be the rich source of information. Traditional libraries consisted of various information media like books, journals, magazines, etc. Technological advancements has resulted in availability of information electronically and ease of access of the information. In its Digital Centre, USCL intends to provide access to all the latest device available to access digital media.

Hence, with the overall objective of improving the citizen service delivery in mind, Ujjain Smart City Limited intends to setup a Digital Centre for the citizens of Ujjain in SimhasthMela Office located on Kothi Road, Ujjain. For this purpose, bids are invited from competent bidders for the supply of equipment, installation and maintenance of the complete system for digital centre.

3.2 Planning and Installation

3.2.1 System Planning and approvals from the client

The Successful Bidder (Agency) is required to review the design & BOQ prepared by USCL and prepare a detailed design of the defined area for the development of Digital Centre. After the finalisation of detailed plan, bidder is supposed to develop a Digital Centre as per the approved plan.

3.2.2 Site Preparation

The Agency is first required to prepare the site, before the installation of devices & equipment in the digital centre. For the preparation of site, agency shall complete designer painting work including putty.

3.2.3 Installation Schedule

The Agency is required to formally launch the Digital Centre within 4weeks after the site clearance/ agreement, whichever is later.

3.2.4 Technical Standards –Equipment & Interior

All the Equipment& Interior shall be of at least with the specifications as mentioned in the RFP.

The Agency will ensure that all equipment procured for the project are new and have not been put to commercial use anywhere prior to the Commencement of Operations.

The Agency will present the specifications of all the equipment to client for inspection. Client will have the right to review all hardware and software to ensure they meet all the technical criteria as specified. Client will accept equipment, which may have features over and above the prescribed minimum standards.

Should client find any discrepancy between the actual specifications of the equipment and the technical specifications mentioned in this RFP, the Agency will have to replace and provide equipment as per prescribed minimum standards or above. The Agency shall provide aesthetically good colours and design for the walls of Digital Centre as per the minimum standards mentioned in this RFP.

The final designs/plan/specifications will be subject to approval from the client. After receiving approval on the final design/plan/specifications, the Agency may proceed with the design of Digital Centre &instalment of equipment in it.

3.2.5 Human Resource Plan

The Agency will

- Hire adequate staff to ensure that scope of services as mentioned in the RFP are met
- Provide support specialist for entire duration of operation & maintenance period

3.2.6 Number of Devices

- Procure Devices as per the requirements of the client, each of which shall comply with the technical standards. The number of the devices can be increased at the discretion of the client.
- Client may increase or decrease the number of devices mentioned in BOQ, and Agency is required to supply additional devices at quoted price.

In general, the incremental change in number can be made by client on an ad-hoc basis depending on the need/demand.

The Service Levels are required to be complied with by the agency as per the service level benchmarks of this document. Failure to comply with SLAs will attract penalties as specified.

3.2.7 Hours of Operation

As per the working hours (and in some cases 24 X 7) of the location or subject to approval of client for all days in a year. The client shall provide space and suggest locations for implementation of Digital Centre. Hours of Operations can be increased / changed / decreased as per requirement.

3.2.8 Data Transfer to client

Agency is required to maintain a register to log details of people using the facilities of Digital Centre. The monthly MIS is to be submitted to the client.

3.2.9 User Information System

It is required that a Support Specialist is available to provide any type of support to the users during operating hours.

Support Specialist is also required to maintain a register for entry and exit of people using the digital facility.

3.2.10 Data Reporting

During the Operation Period,

- The Agency shall make available all the data pertaining to the Operation & Maintenance of the Project real-time that can be accessed by the client or its representative. The real-time data shall be in such a format that the client shall be able to evaluate the performance of the Agency against the Service Levels set forth in this Agreement.
- The Agency shall no later than 7 (seven) days after the close of each month, furnish to the client, a monthly report stating in reasonable detail the condition of the Project including its compliance with Service Level Benchmarks. In particular, such report shall separately identify and state in reasonable detail the defects and deficiencies that require rectification.
- The agency shall no later than 14 (fourteen) days after the close of each quarter furnish to the client a Quarterly report stating in reasonable detail the condition of the Project including details of Mobile Charging locations with maximum demand and low demand, time of the day when there is maximum demand, steps that can be taken to improve user experience and quality of service including plans of expansion into newer areas.
- The client may request the agency for any additional information other than the real-time data if need be.

3.3 Legal

The Agency is required to

- Bear all applicable National, State and local taxes on purchase of equipment.
- Bear all the risks incurred on vandalism and loss of the system- electronic equipment, table, chairs and other components within the premises.
- Bear all applicable insurance, including equipment insurance of all the components of the system as required under:
 - Any Financing Agreements of Laws of India
 - Such Insurances as may be necessary in accordance with the Prudent Practices.

3.4 Technical & Functional Specifications

The solution is proposed to be implemented in a room located at MelaKaryalay, Ujjain so the expectation is to prepare the site first, get the layout approved from the client and then complete the installation of digital devices as per the requirements.

3.4.1 Functional Requirements for Wireless Networking

#	Requirement	Functionality
1	Internet Connection	An internet connection with seamless connectivity is required with the bandwidth of at least 4 mbps with unlimited download. Bidder can provide either broadband or 3G/4G connectivity as per the proposed network architecture. Bidder is required to provide a standby internet connection of same bandwidth for seamless connectivity.
2	Router	Router must be able to connect with more than 20 wireless devices at a time. Router must have simultaneous connectivity of 2.4 and 5 Ghz. In case bidder is proposing a 3G/4G internet connection, the router must be able to connect with at least 2 3G/4G dongles. Router must have built-in firewall for blocking user-defined or customized restricted content and websites. Router must be able to bind the machine identity so that any outside phone or laptop cannot connect with wireless router.

3.4.2 Functional Requirements for Display Security Stand for Tablets

#	Requirement	Functionality
1	Tablet Display Security Stand	<p>The Tablet Display Security Stand must be standalone device without any centralized controller. The device must have a built-in security sensor and alarm triggers automatically at the event of theft.</p> <p>The device must be robust for public usage. The device should have battery backup for continued functionality in the event of power failure.</p> <p>The device must come with a remote control to enable/disable the alarm notification. The device should have spiral cable which should expand for at least 1 meter.</p>

3.4.3 BOQ

The proposed solution is required to have the following components as per the BOQ:

#	Item Description	Qty
1	All New Kindle Oasis - 7" High Resolution Display, Waterproof, 32 GB, Wi-Fi + free 3G and Kindle Unlimited package for downloading books	4
2	Apple iPad mini 4 128 GB Wi-Fi	1
3	Apple iPad Pro 12.9 inch 64GB Wi-Fi	1

#	Item Description	Qty
3	Microsoft Surface Pro 4 (Core i5, 4GB, 128GB, 12.3")	2
4	Android Tablet – 9", 32GB internal memory, 3GB RAM, Android Oreo, Full HD Resolution, Cameras at Front and Back, Wi-Fi	2
5	Over Ear Headphone with built-in Microphone, High Bass Sound, (Sony, Logitech, Philips, Sennheiser or equally reputed brand) – Should have ability to connect to all of the above devices.	5
6	Router with built-in firewall	1
7	Internet Connection with 4 Mbps Bandwidth (Unlimited Download)	2
8	Tablet Display Security Stand	10
9	Executive Table as per specification – Teak Wood – Designer	1
10	Executive Chairs as per specification – Mesh Revolving Chair with back support	10
11	Air Conditioner – 1.5 Tonne Split AC (Make Blue Star, Hitachi, Carrier, Daikin or equivalent) – 5 Star Rating – with total 5 years Annual Maintenance Plan and Warranty. With Voltage Stabilizer	1
12	Portable Fire Extinguisher for Electronic Devices	1
13	Lacquered Glass White Notice Board 8 ft. X 4ft Toughened	1
14	Soft Board 8 ft X 4 ft	1
15	Book Shelf as per specification – Teak Wood	2
16	Painting and Civil / Electrical work	Lump-sum
17	Support Specialist	Available from 9AM thru 9PM on all days except national holidays.
18	UPS – 30 minutes power backup and Voltage Protection	As required
19	Name Board – 6 sq. ft.	1

1. Bidders are encouraged to provide better specifications than that available.
2. All devices are required to have at least two years warranty and accidental damage protection.
3. Portability - these devices/setup should be portable and can be placed anywhere for a long or short period
4. Voltage Protection System
5. Power Backup for at least 30 minutes
6. All furniture and equipment are required to be pre-approved by the Client before installation.

3.5 Implementation

3.5.1 Contract Period

This Contract is being granted for the installation and operation of the digital centre equipment for a contract period of 1 year from the date of installation. This is a single Agency contract, who will execute the project in end-to-end manner.

3.5.2 On Ground Testing

The Agency is required to run an on ground test of the system equipment for at least 3 days before the formal launch of the system and equipment to the general public. The Agency to identify any service glitches in the system and correct it before Go-Live. The Agency shall make available the Staff required for operations and maintenance of the components for digital centre, which are being tested.

3.5.3 Maintenance

The agency needs to ensure that the digital devices and all other assets of the digital centre are regularly maintained according to the maintenance schedule as finalized by the client after consultation with the Agency.

Client shall provide the space and raw power. All the utility and other charges will be borne by the Vendor.

3.6 Deliverables

The Agency will be expected to provide the monthly report to the client mentioning all the necessary statistics of the project to understand clearly the progress adoptability of the digital centre by the public.

- Detailed Plan along with periodical Project Status Reports
- Procedure Manuals related to installation, operation, administration (including backup and restoration) and such other details.
- Devices & equipment in the location determined by USCL or other client agencies

3.7 Deliverables, Timelines & Payment Terms

During project the Service Provider shall submit the deliverables as mentioned below as per the timelines mentioned below.

Sr. No.	Activity	Timeline	Payment
1.	Implementation / Project Go Live including Procurement, Installation and Commissioning of all equipment as per the contract	Within 4 Weeks	60%
2.	O&M - Warranty - SLA support - MIS / Reporting, etc.	1 years after Go Live	35% to be paid on a monthly basis.
3.	Hand-over of the system		5%

- Payments shall be made by USCL after obtaining a no-objection certification from relevant authorities, subject to any deductions.
- Reasonable variation shall be allowed in the contract and payment terms as per the discretion of the USCL.

3.8 Service Level Benchmarks

The client will monitor the digital centre as per the SLB below. The Client has the right to deduct the monthly payment or to demand penalty payment in case of default by the agency as per the deductions mentioned.

Sl. No.	Service Level Benchmark	Penalty
1	Operating times	Centre should be operational on all hours from 9AM thru 9PM on all days except national holidays. In case of non-adherence to these operational hours, a penalty of Rs. 500 per hour shall be applied.
2	Working Devices	Devices should be operational for 95% of time on all hours as specified in operating times. Total operational time = total time X number of devices. Measured through complaints / log books

Sl. No.	Service Level Benchmark	Penalty
3	Availability of Internet	Internet on devices should be operational for 95% of times. Measured through complaints / log books
4	Weekly and Monthly MIS to be submitted to the Client	Rs. 1,000 (Rupees One Thousand) or 5% of Monthly Amount Payable due (whichever is higher). An instance will be valid till 24 hours after which it shall be counted as a new instance.

3.9 Damages

The agency will be responsible for all damages to the devices and equipment in the digital centre. Damage to Project Asset due to regular wear and tear under filed conditions, or breach of its maintenance obligations or any other obligations specified in this Agreement and/ or omission of act by the agency shall be the liability of the agency. In such case agency shall repair and rectify at its own cost the damages to the satisfaction of the client. All insurance proceeds if any shall be applied in rectification/repair of Project Assets. Damages due to vandalism and theft are also the responsibility of the agency, who should be insured against such losses.

The client shall not be liable to make any payments including those arising from maintenance or operations of the devices and equipment in the digital centre.

3.10 Summary of responsibilities

The following list is a representative but not exhaustive summary of the respective responsibilities of the Agency and the client.

3.10.1 The Client

- Provision of location for setup of digital centre.
- Ensuring clearance and approval from required authorities for installation and operation of the centre
- Specification of centre branding and naming as per proposed and approved by the department.
- Review of agency plans including operation and maintenance plan
- Review of monthly operations report
- Co-ordination with other government departments, when required.

3.10.2 The Agency

- Procurement of digital devices & equipment
- Establishment of digital centre
- Planning & designing of digital centre
- Regular Maintenance of devices and digital centre space
- Planning and hiring adequate staff with the right capabilities
- Data Reporting- Weekly/Monthly/Quarterly Reports (System Planning)
- Log of all persons visiting the site is required to be kept. A feedback form is also required to be prepared and kept and all persons visiting be encouraged to fill in the feedback form.
- Legal – Insurance (all risk of vandalism on operator)

3.11 Resource Person

The Resource Person or Persons deployed shall man the premises at the hours specified as per the Service Level Benchmarks.

The Resource person should hold at least a Diploma in Information Technology / Computer Science. Responsibilities include maintaining the assets created as part of this project, providing training and handholding to citizens / other personnel resources of the government in Ujjain / conducting training workshops on topics related to IT / Computer Science (which shall be discussed / finalized by the Client) and in general supporting the client in any other ICT related activities.

An attendance sheet shall be prepared and maintained by the resource person(s), which shall be signed daily.

3.12 Extension / Variation of the system

Extension or variation of system in future will be done as per the requirements of the solution with mutual agreement between the client and the agency.

3.13 No Additional Fees from user for the services

The Agency or the staff should not collect any additional fees. Tipping or any exchange of money for preferential service is prohibited and any staff engaging in such a practice should be disciplined accordingly.

However, should the USCL decide to charge any fees from individuals for use of the facilities / services, the agency may be required to collect and deposit the fees / charges in the same day to the bank as mentioned by the client.

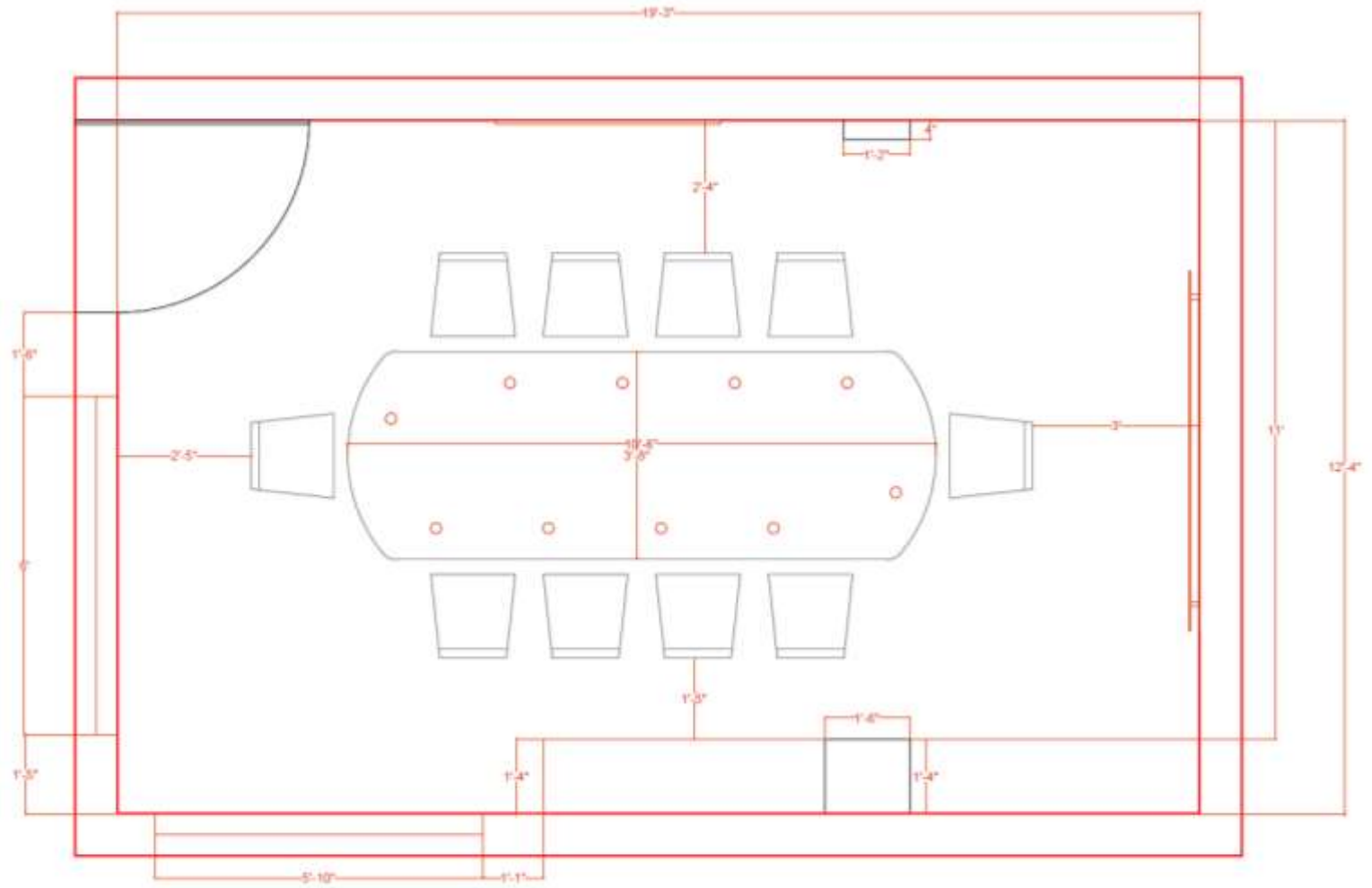

PLAN

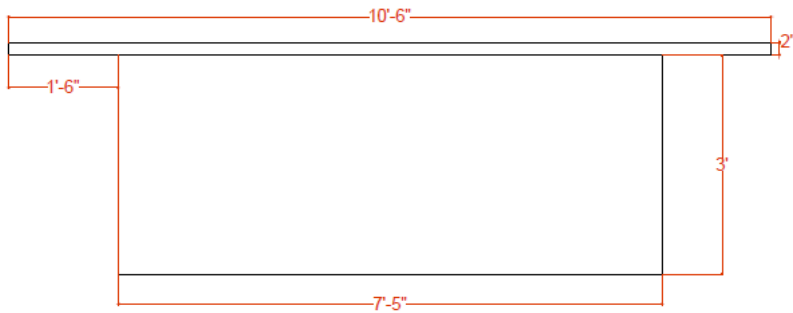

FRONT ELEVATION OF TABLE

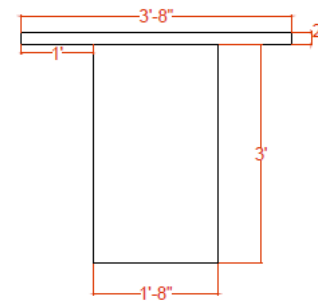

SIDE ELEVATION OF TABLE

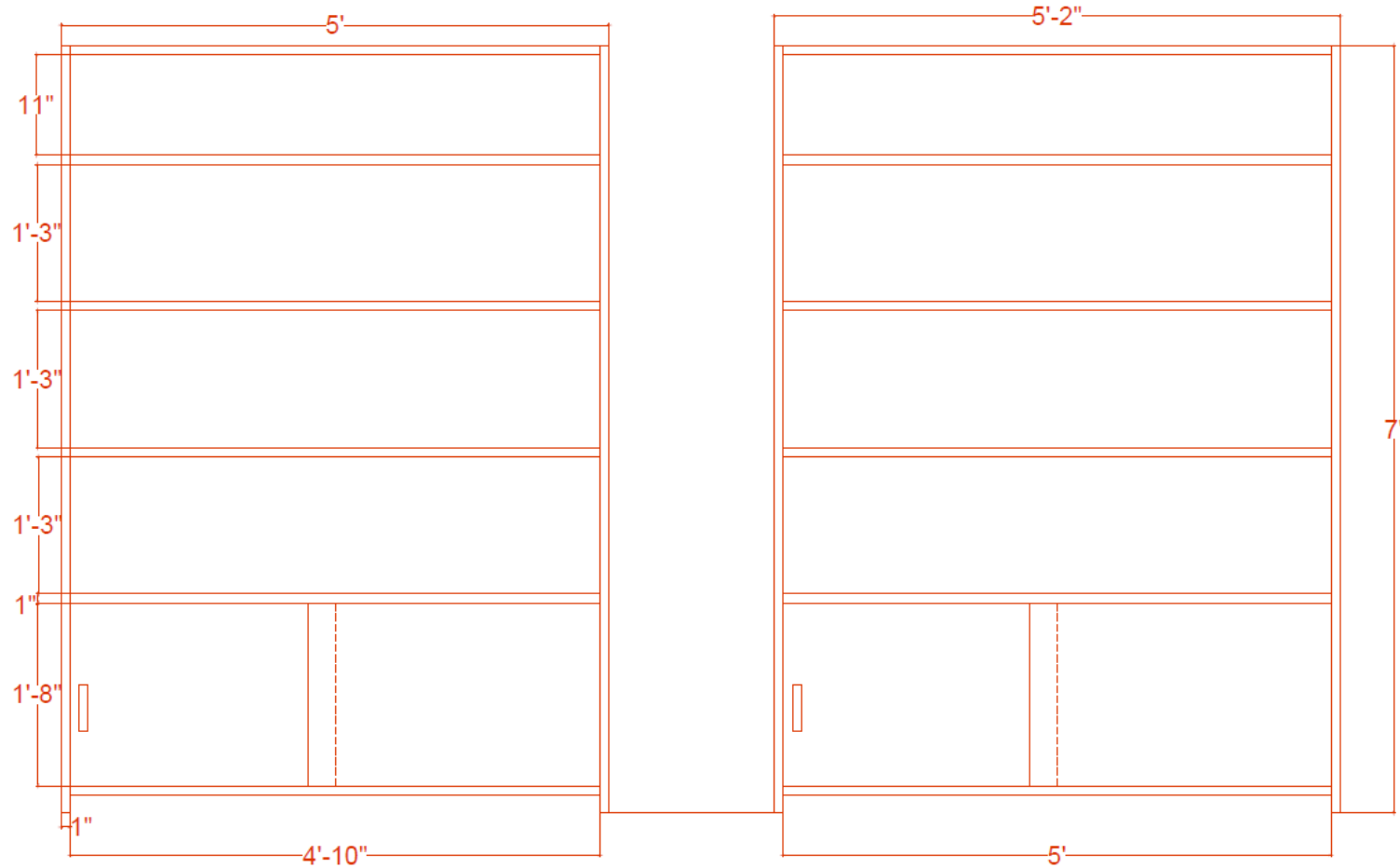

ELEVATION OF BOOK SHELF

4 Model Master Agreement

<<TO BE PREPARED ON STAMP PAPER OF APPROPRIATE VALUE. IN CASE THERE IS A CHANGE IN THE CONTRACT AMOUNT / VALUE, ADDITIONAL STAMP PAPERS MAY BE REQUESTED BY THE CLIENT.>>

This Contract is made and entered into on this day of <<MONTH>>, 2018 by and between

“**UJJAIN SMART CITY LIMITED**” (hereinafter referred to as **CLIENT**), which expression shall include its successors, administrators, executors and assignees) on the one part

and

XXXX having its office at XXXXreferred to as the “Agency” or the “SI” or “Agency” (which expression shall include its successors, administrators, executors and permitted assignees) on the other part.

Each of the parties mentioned above are collectively referred to as the ‘Parties’ and individually as a ‘Party’.

Whereas

1. Client has desired for Selection of <<PROJECT NAME>> conforming to specifications as set forth in the Scope of Work in the RFP issued.
2. And Whereas the Agency represents that it has the necessary capabilities for carrying out the said works as referred to herein and has submitted a bid for providing the required services against Tender No XXXX all in accordance with the terms and conditions set forth herein and any other reasonable requirements of the Client from time to time.
3. And Whereas Client has accepted the bid of the Agency and has placed Letter of Acceptance / Notification of Award vide its letter No. XXXXXX on the Agency.

NOW THEREFORE, in consideration of the mutual covenants, promises, assurances, representations and provisions set forth herein, the Parties hereto agree as follows:

Definitions:

4. In this Contract, the following terms shall be interpreted as indicated:
 - a) “Business Day” means any day that is not a Sunday or a public holiday (as per the official holidays observed by Client;
 - b) “Confidential Information” means any information disclosed to or by any Party to this Contract and includes any information in relation to the Parties, a third party or any information with regard to any registrant, or any other person who is covered within the ambit of any legislation related to Client, including any such information that may come to the knowledge of the Parties hereto / Bidder’s Team by virtue of this Contract that:
 - is by its nature confidential or by the circumstances in which it is disclosed confidential; or
 - is designated by the disclosing Party as confidential or identified in terms connoting its confidentiality;
 - but does not include information which is or becomes public knowledge other than by a breach of this Contract;
 - But does not include information which is in receiving party's possession prior to receipt from the disclosing party.

- But does not include information which is independently developed or learned by the receiving party.
 - But does not include information which is disclosed by the receiving with the prior written approval of the disclosing party.
- c) “Contract” means the Agreement entered into between the Client and the “Agency” as recorded in the Contract form signed by the Client and the “Agency” including all attachments and Annexes thereto, the Tender and all Annexes thereto and the agreed terms as set out in the bid, all documents incorporated by reference therein and amendments and modifications to the above from time to time;
 - d) “Agency’s Representative” means the person or the persons appointed by the Agency from time to time to act on its behalf for overall co-ordination, supervision and project management.
 - e) “Document” means any embodiment of any text or image however recorded and includes any data, text, images, sound, voice, codes or and databases or microfilm or computer generated micro fiche.
 - f) “Effective Date” means the date on which this Contract is signed and executed by the parties hereto. If this Contract is executed in parts, then the date on which the last of such Contracts is executed shall be construed to be the Effective Date;
 - g) “Intellectual Property Rights” means any patent, copyright, trademark, trade name, design, trade secret, permit, service marks, brands, propriety information, knowledge, technology, licenses, databases, computer programs, software, know how or other form of intellectual property right, title, benefits or interest whether arising before or after the execution of this Contract and the right to ownership and registration of these rights;
 - h) “Kick off Meeting” means a meeting convened by the Client to discuss and finalize the work execution plan and procedures with Agency.
 - i) The “SI” means the company / consortium with whom the order has been placed for providing Services as specified in this tender/Contract and shall be deemed to include the Agency's successors, representatives (approved by the Client), heirs, executors, administrators and permitted assigns, as the case may be, unless excluded by the terms of the Contract.
 - j) “Lead Bidder” is the entity which is mentioned in the Consortium Agreement as such and in whose favour the LOA is issued by Client.
 - k) “Agency’s Team” means the successful Bidder who has to provide services to the Client under the scope of this Tender / Contract. This definition shall also include any and/or all of the employees of Bidder, their authorized agents and representatives and approved Sub-Implementation Agencies or other personnel employed or engaged either directly or indirectly by the Agency for the purposes of the Contract.
 - l) “Parties” means the Client and the Agency and “Party” means either of the Parties;
 - m) “Service” means facilities/services to be provided as per the requirements specified in this tender document and any other incidental services, such as installation, implementation, maintenance, provision of technical assistance and other such obligations of the Agency covered under the Contract;
 - n) “Service Specification” means and include detailed description, statements to technical data, performance characteristics, and standards as applicable and as specified in the Contract as well as those specifications relating to Industry standards and codes applicable to the performance of the work, work performance quality and the specifications affecting the works or any additional specification required to be produced by the Agency to meet the design criteria.
 - o) “Sub-Agency” means any person or persons or firm/company or their legal representatives, successors, assignees to which part of the Contract has been outsourced by the Agency after necessary consent of Client.
 - p) “The Contract Price/Value” means the price payable to the Agency under the Contract for the full and proper performance of its Contractual obligations;

Interpretation

5. In this Agreement, unless otherwise specified:
 - a) wherever the term Agency is used, it shall mean the Bidder, as applicable. In this Contract unless a contrary intention is evident:
 - b) the clause headings are for convenient reference only and do not form part of this Contract;
 - c) unless otherwise specified a reference to a clause number is a reference to all of its sub-clauses;
 - d) unless otherwise specified a reference to a clause, sub-clause or section is a reference to a clause, sub-clause or section of this Contract including any amendments or modifications to the same from time to time;

- e) a word in the singular includes the plural and a word in the plural includes the singular;
- f) a word importing a gender includes any other gender;
- g) a reference to a person includes a partnership and a body corporate;
- h) a reference to legislation includes legislation repealing, replacing or amending that legislation;
- i) where a word or phrase is given a particular meaning it includes the appropriate grammatical forms of that word or phrase which have corresponding meanings.
- j) in the event of an inconsistency between the terms of this Contract and the Tender and the Bid, the terms hereof shall prevail.
- k) all measurements and calculations shall be in the metric system and calculations done to 2 (two) decimal places, with the third digit of 5 (five) or above being rounded up and below 5 (five) being rounded down except in money calculations where such amounts shall be rounded off to the nearest INR.

Ambiguities within Agreement

- 6. In case of ambiguities or discrepancies within this Agreement, the following principles shall apply:
 - a) as between two Clauses of this Agreement, the provisions of a specific Clause relevant to the issue under consideration shall prevail over those in a general Clause;
 - b) as between the provisions of this Agreement and the Schedules/Annexure, the Agreement shall prevail, save and except as expressly provided otherwise in the Agreement or the Schedules/Annexure; and
 - c) as between any value written in numerals and that in words, the value in words shall prevail.

Priority of Documents

- 7. This Agreement, including its Schedules and Annexure, represents the entire agreement between the Parties as noted in this Clause. If in the event of a dispute as to the interpretation or meaning of this Agreement it should be necessary for the Parties to refer to documents forming part of the bidding process leading to this Agreement, then such documents shall be relied upon and interpreted in the following descending order of priority:
 - a) This Agreement along with the SLA agreement, NDA agreement, Schedules and Annexure, including the tri-partite agreement for the bandwidth;
 - b) Request for Proposal and Addendum / Corrigendum to the Request for Proposal (if any).
- 8. For the avoidance of doubt, it is expressly clarified that in the event of a conflict between this Agreement, Annexure / Schedules or the contents of the RFP, the terms of this Agreement shall prevail over the Annexure / Schedules and Annexure / Schedules shall prevail over the contents and specifications of the RFP

Conditions Precedent

- 9. This Contract is subject to the fulfilment of the following conditions precedent by the Agency:
 - a) Furnishing of an unconditional and irrevocable and continuing **Bank Guarantee for Contract Performance of the sum of Indian Rupees One Lacs (Rs. 1,00,000 /-)** in a form and manner acceptable to the Client which would remain valid until such time and be renewable as may be stipulated by the Client.
 - b) Execution of a Deed of Indemnity and Non-Disclosure Agreement
 - c) Obtaining of all statutory and other approvals required for the performance of the Services under this Contract
 - d) If applicable, the Consortium Agreement should be signed between all the Consortium Members and submitted to Client.

Representations & Warranties

10. In order to convince the Client to enter into this Contract, the Agency hereby represents and warrants as of the date hereof, which representations and warranties shall survive the term and termination hereof, the following:
- a) it is duly organized and validly existing under the laws of India, and has full power and authority to execute and perform its obligations under this Agreement and other agreements and to carry out the transactions contemplated hereby;
 - b) That the Agency has the requisite experience in providing the services, the technical know-how and the financial wherewithal, the power and the authority that would be required to successfully provide the Services sought by the Client for the purposes of this Contract;
 - c) That the Agency is not involved in any major litigation or legal proceedings, pending, existing, and potential or threatened, that may have an impact of affecting or compromising the performance or delivery of Services under this Contract;
 - d) That the representations and warranties made by the Agency in the bid or will be made in this Contract are and shall continue to remain true and fulfil all the requirements as are necessary for executing the obligations and responsibilities as laid down in the Contract and the Tender and unless the Client specifies to the contrary, the Agency shall be bound by all the terms of the Bid and the Contract through the term of the Contract;
 - e) That the Agency has the professional skills, personnel and resources/authorizations that are necessary for providing all such services as are necessary to fulfil the Scope of Work stipulated in the Tender and this Contract;
 - f) That there shall not be any privilege, claim or assertion made by a third party with respect to right or interest in, ownership, mortgage or disposal of any asset, property, movable or immovable as mentioned in any Intellectual Property Rights, licenses and permits;
 - g) That the Agency shall use such assets of the Client as the Client may permit for the sole purpose of execution of its obligations under the terms of the Bid, Tender or this Contract. The Agency shall however, have no claim to any right, title, lien or other interest in any such property, and any possession of property for any duration whatsoever shall not create any right in equity or otherwise, merely by fact of such use or possession during or after the term hereof;
 - h) That the Agency shall procure all the necessary permissions and adequate approvals and licenses for use of various software and any copyrighted process/product free from all claims, titles, interests and liens thereon and shall keep the Client indemnified in relation thereto;
 - i) That the execution of the Services and the Scope of work herein are and shall be in accordance and in compliance with all applicable laws.;
 - j) That all conditions precedent under the Contract has been satisfied;
 - k) That neither the execution and delivery by the Agency of the Contract nor the Agency's compliance with or performance of the terms and provisions of the Contract;
 - i. will contravene any provision of any Applicable Law or any order, writ, injunction or decree of any court or Governmental Authority binding on the Agency;
 - ii. will conflict or be inconsistent with or result in any breach of any or the terms, covenants, conditions or provisions of, or constitute a default under any Contract, Contract or instrument to which the Agency is a party or by which it or any of its property or assets is bound or to which it may be subject or
 - iii. will violate any provision of the Memorandum and Articles of Association of the Agency;
 - l) That time is the essence of the Contract and hence the Agency shall at all times maintain sufficient manpower, resources, and facilities, to provide the Services in a workmanlike manner on a timely basis.
 - m) That its security measures, policies and procedures are adequate to protect and maintain the confidentiality of the Confidential Information.
 - n) That the hardware, software, and the services implemented under the Kiosk System shall be:
 - a. In accordance with the standards laid out in the RFP by the client for the Kiosk System and those provided during the term of the agreement;
 - b. As per the specifications given in the RFP and meeting all mandatory, legal and other statutory requirements;
 - c. Compliant with the Technical Specifications set forth;
 - i. Fit and sufficient for the purpose(s) for which they are designed and developed;
 - ii. Be new;
 - iii. Be certified or registered with the concerned Agency after completing all legal, statutory, and other requirements,
 - iv. Be free from defects in design, material and workmanship, whether latent or

- o) That neither any component of the Kiosk System nor any use thereof by the client will infringe any patent, trademark, copyright, trade secret, or other proprietary right of a third party.
 - p) That any service that is provided by the Agency hereunder shall be performed in a competent manner and be for any purpose for which Agency knows or has reason to know the client's intends to use such service .
 - q) Agency hereby agrees that the above stated Representations and Warranties (i) shall survive the inspection, acceptance and use of the Kiosk System by the client or any other authorized Agency; (ii) are for the benefit of the client; and (iii) are in addition to any warranties and remedies to which the client may otherwise agree or which are provided by law.
11. The Client or its nominated agencies represent and warrant to the 'Agency' that:
- a) it has full power and authority to execute, deliver and perform its obligations under this Agreement and to carry out the transactions contemplated herein and that it has taken all actions necessary to execute this Agreement, exercise its rights and perform its obligations, under this Agreement and carry out the transactions contemplated hereby;
 - b) it has taken all necessary actions under Applicable Laws to authorize the execution, delivery and performance of this Agreement and to validly exercise its rights and perform its obligations under this Agreement;
 - c) it has the financial standing and capacity to perform its obligations under the Agreement;
 - d) it is subject to the laws of India, and hereby expressly and irrevocably waives any immunity in any jurisdiction in respect of this Agreement or matters arising there under including any obligation, liability or responsibility hereunder;
 - e) this Agreement has been duly executed by it and constitutes a legal, valid and binding obligation enforceable against it in accordance with the terms hereof and its obligations under this Agreement shall be legally valid, binding and enforceable against it in accordance with the terms thereof;
 - f) the execution, delivery and performance of this Agreement shall not conflict with, result in the breach of, constitute a default under, or accelerate performance required by any of the Applicable Laws or any covenant, contract, agreement, arrangement, understanding, decree or order to which it is a party or by which it or any of its properties or assets is bound or affected;
 - g) there are no actions, suits or proceedings pending or, to its knowledge, threatened against it at law or in equity before any court or before any other judicial, quasi-judicial or other authority, the outcome of which may result in the default or breach of this Agreement or which individually or in the aggregate may result in any material impairment of its ability to perform its material (including any payment) obligations under this Agreement;
 - h) it has no knowledge of any violation or default with respect to any order, writ, injunction or any decree of any court or any legally binding order of any Government Instrumentality which may result in any Adverse Effect on the Client or its nominated agencies ability to perform its obligations under this Agreement and no fact or circumstance exists which may give rise to such proceedings that would adversely affect the performance of its obligations under this Agreement;
 - i) it has complied with Applicable Laws in all material respects;
 - j) all information provided by it in the RFP in connection with the Project is, to the best of its knowledge and belief, true and accurate in all material respects; and
 - k) upon the Agency performing the covenants herein, it shall not at any time during the term hereof, interfere with peaceful exercise of the rights and discharge of the obligations by the Agency, in accordance with this Agreement

Execution of Work Order

- 12. In the event of tender being submitted with consortium of partners, the Lead Bidder alone will be liable or responsible to the Client for due fulfilment of terms and conditions of the tender including installation, commissioning, operation, management and maintenance of the entire project.
- 13. The Successful Bidder should nominate and intimate Client a Project Manager specifically to handle the Work Order from Client and ensure that he fully familiarizes with the terms and conditions of the tender, scope of work, Work Order and the guidelines, and is responsible to effectively execute the Work Order complying all the terms and conditions.

14. In the event of tender being submitted with consortium of partners, the consortium cannot change its constituent partners during the execution of the work order without the express written permission from the client.

Assigning of Tender Whole or In Part

15. The Agency should not assign or make over the Contract, the benefit or burden thereof to any other person or persons or body corporate except declared consortium partners. They should not underlet or sublet to any person/s or body corporate except declared consortium partners for the execution of the Contract or any part thereof unless a proper approval for subletting is obtained from the Client.

Scope of work/Contract

16. Scope of the Contract shall be as defined in this RFP and the Corrigendum / Addendum issued with respect to this RFP.

General Requirements

17. The Agency shall study and understand the existing processes and RFP thoroughly.
18. The service delivery shall be of the highest quality.
19. The Agency should make his own arrangements to obtain all the material required for this work such as PCs, printers, scanners, adequate human resource, stationery deemed necessary at various stages of the project.
20. It shall be obligatory for the Bidder to furnish Certificate, if demanded by the Department from manufacturer or the material supplier that the work has been carried out by using their material and as per their Recommendation
21. All electrical materials conforming to the Indian Standard Specification shall be used and the materials must comply with relevant standard specifications

Deviations

22. The tender should be for the complete scope of work and services. However, in case of any minor deviations, the Bidder should clearly and separately state the item that is in deviations in their tender. This should be clearly stated under deviations head quoting the index and serial references in Technical Specifications. Any deviation mentioned elsewhere in the tender but not clearly stated under this section should not be considered. The Bidder should also clearly indicate the services and utilities to be provided by the Department including their obligations, if any. Client reserves the right to consider or reject these deviations of the tender.

Storage & Risk

23. The Successful Bidder should make arrangements for transportation to site and build their own stores for the intermediate storage of equipment, maintain the stores and all related documents and records, transport the equipment to site. Agency shall at his own expense adopt suitable Risk Management methodology to mitigate all risks assumed by the Agency under this Contract. Agency shall underwrite all the risk related to its personnel deputed under this Contract as well as equipment and components of the Client, procured for the Client, equipment, tools and any other belongings of the Agency or their personnel during the entire period of their in connection with this Contract and take all essential steps

to reduce and mitigate the risk. Tendering Authority or State Government will have no liability on this account.

Duration of the Contract

24. The Contract shall remain valid for a period of 1 Years exclusive of setup / implementation, unless extended in writing by both the parties.

Performance Bank Guarantee

25. The Successful Bidder is required to remit the Performance Bank Guarantee equivalent to <<INDIAN RUPEES ONELACS ONLY>> in the form of unconditional irrevocable Bank Guarantee for a period of Six years from the date of LOA, within fifteen days from the date of LOA. If the accepted Bidder fails to remit the Performance Bank Guarantee within the above said period, their tender will held void and the Earnest Money Deposit remitted by them will be forfeited to Client.

Agency's Obligations

26. Agency should perform the Services specified by the Client and make available the necessary equipment / facilities / services as may be necessary and other 'Scope of work' requirements as specified in the tender and changes thereof.
27. The Agency shall ensure that the Agency's Team is competent, professional and possesses the requisite qualifications and experience appropriate to the task they are required to perform under this Contract. The Agency shall ensure that the Services are performed through the efforts of the Agency's Team, in accordance with the terms hereof and to the satisfaction of the Client. Nothing in this Contract relieves the Agency from its liabilities or obligations under this Contract to provide the Services in accordance with the Client directions and requirements and as stated in this Contract and the Bid to the extent accepted by the Client and the Agency shall be liable for any non-performance, non-compliance, breach or other loss and damage resulting either directly or indirectly by or on account of its Team.
28. Third party claims - The selected Agency(s) shall indemnify Client against all third-party claims of infringement of patent, trademark or industrial design rights arising from use of the Goods or any part thereof in India.
29. Delivery and documentation - Delivery of Goods shall be made by the selected Agency strictly in accordance with the specifications of the tender document or in case of deviations, the specifications approved and accepted by the Client.
30. Ownership of equipment - All the equipment provided by the selected Agency(s) shall virtually have the right to use of the property by Client throughout the Contract period though the ultimate transfer may come much later, after the expiry of the Contract period. The selected Agency will therefore not shift, move, and transfer the equipment without the prior consent of the Client. Such a request by the Agency should be made with suitable justification and reasoning. However, the Agency will be allowed to carry out normal maintenance activities as scheduled. It should be noted that if equipment has to be replaced, the replacement must have a manufacturing date later than that of the equipment being replaced and the configuration of the replacement should be same or higher. Information about all such replacements along with reasons for should be provided in writing to Client.
31. Any equipment or material purchased, procured or developed as a result of this Contract shall belong to Client.
32. Ownership of all the data created during the period of Contract shall be the property of the Client, however, the responsibility of its maintenance, updating, correctness and backup would be that of Agency.
33. No third party interest in any form (lien, mortgage, hypothecation etc.) without the prior approval and consent of the Client, can be created on the assets, equipment etc. installed by the selected Agency (s).

34. The Agency is required to ensure that at least one Senior Staff (Project Leader / Project Manager) who is capable of decision making and required coordination on day-to-day operations of the project are seated full-time at Client Office in Ujjain, for the rollout and O&M of the project.
35. Interpretation of Clauses - In case of any ambiguity in the interpretation of any of the clauses in the RFP, the interpretation of the clauses by Authorized Representative of Client shall be final and binding on all parties.

Agency's Representative

36. In case of a consortium, all the entities shall individually appoint their representative in the consortium for purposes of execution of this agreement and communicate the same to Client in writing.
37. Unless otherwise agreed with the Client, the named Project Manager shall be the Agency's Representative.
38. The Agency's representative shall have all the powers requisite for the performance of services under this Contract. The Agency's Representative shall liaise with the Client Representative for the proper coordination and timely completion of the works and on any other matters pertaining to the works. He will extend full co-operation to Client representative in the manner required by them for supervision / inspection / observation of the facilities, equipment / material, procedures, performance, reports and records pertaining to the works. He shall also have complete charge of the Agency's personnel engaged in the performance of the works and to ensure internal discipline, compliance of rules, regulations and safety practice. He shall also co-ordinate and co-operate with the other Agencies/Agency of the Client working at the Site/offsite for activities related to planning, execution of scope of work and providing services under this Contract.

Reporting Progress

39. Agency shall monitor progress of all the activities specified in the Contract and submit fortnightly and monthly progress report about various aspect of the work to the Client. The Client on mutual agreement between both parties may change the periodicity of such reports. Extracts of the progress report to be termed, as "Executive Summary" shall be submitted in 1 hard copy, along with 1 copy of monthly progress report.
40. The Infrastructure facilities / services, and manpower to be provided by the Agency under the Contract and the manner and speed of execution and maintenance of the work are to be conducted in a manner to the satisfaction of Client representative in accordance with the Contract. The rate of progress of the work, compliance to the requirements of the Data Centre and departmental offices/its facilities, or any part of them at any time fall behind the stipulated time for completion or is found to be too slow to ensure completion of the works or insufficient for satisfactory operation of the Client, Client representative may so notify the Agency in writing.
41. The Agency shall reply to the written notice giving details of the measures he proposes to take to expedite the progress so as to complete the works by the prescribed time. The Agency shall not be entitled to any additional payment for taking such steps. If at any time it should appear to the Client or Client representative that the actual progress of work does not conform to the approved programme the Agency shall produce at the request of the Client representative a revised programme showing the modification to the approved programme necessary to ensure completion of the works within the time for completion or steps initiated to ensure compliance/improvement to the stipulated requirements

Knowledge of Site Conditions

42. The Agency's undertaking of this Contract shall be deemed to mean that the Agency possesses the knowledge of all the related requirements as stipulated in the Tender Document including but not

limited to environmental, demographic and physical conditions and all criteria required to meet the design of the systems.

43. The Agency shall be deemed to have understood the requirements and have satisfied himself with the data contained in the Bidding Documents, the quantities and nature of the works and materials necessary for the completion of the works, etc., and in-general to have obtained himself all necessary information of all risks, contingencies and circumstances affecting his obligations and responsibilities therewith under the Contract and his ability to perform it. However, if during the process of site preparation and installation of the equipment at the locations, as required by Client, Agency detects any obstructions affecting the work, the Agency shall take all measures to overcome them.
44. Agency shall be deemed to have satisfied himself as to the correctness and sufficiency of the Contract Price for the works. The consideration provided in the Contract for the Agency undertaking the works shall cover all the Agency's obligation and all matters and things necessary for proper execution and maintenance of the works in accordance with the Contract and for complying with any instructions which the Client Representative may issue in accordance with the connection therewith and of any proper and reasonable measures which the Agency takes in the absence of specific instructions from the Client Representative.

Agency's Team

45. The Agency shall submit to the Client 7 days prior to the effective date of commencement of works / services or kick-off meeting whichever is earlier, an organization chart showing the proposed organization/manpower to be established by the Agency for execution of the work/facilities including the identities and Curriculum-Vitae of the key personnel to be deployed. The Agency shall promptly inform the Client in writing, of any revision or alteration of such organization charts.
46. The team proposed by the Agency as a part of the technical proposal should be deployed at Client. Any change in the team profile should be brought in to the notice of Client. Agency should ensure that any replacement personnel, if unavoidable, is equivalent or better than the original personnel in terms of experience and qualification.
47. The Agency shall be responsible for the deployment, transportation, accommodation and other requirements of all its employees required for the execution of the work and for all costs/charges in connection thereof.
48. The Agency shall provide and deploy, on the Site for carrying out the work, only those manpower resources who are skilled and experienced in their respective trades and who are competent to execute or manage/supervise the work in a proper and timely manner. Any deviation from the team proposed in the Technical Bid shall be given to Client as and when required.
49. The Client Representative may at any time object to and require the Agency to remove forthwith from the site a supervisor or any other authorized representative or employee of the Agency or any person(s) deployed by Agency or his agent / sub-Contractor, if, in the opinion of the Client Representative the person in question has misconduct himself or his deployment is otherwise considered undesirable by the Client Representative the Agency shall forthwith remove and shall not again deploy the person in question of the work site without the written consent of the Client Representative.
50. The Client Representative may at any time request the Agency to remove from the work / Site the Agency's supervisor or any other authorized representative including any employee of the Agency or his sub-Agency or any person(s) deployed by Agency or their agent / sub-Contractor for professional incompetence or negligence or for being deployed for work for which he is not suited. The Agency shall consider the Client Representative Request and may accede to or disregard it. The Client Representative, having made a request, as aforesaid in the case of any person, which the Agency has disregarded, may in the case of the same person at any time but on a different occasion, and for a different instance of one of the reasons referred to above in this Clause object to and require the Agency to remove that person from deployment on the work, which the Agency shall then forthwith do and shall not again deploy any person so objected to on the work or on the sort of work in question (as the case may be) without the written consent of the Client Representative.

51. The Client Representative shall state to the Agency in writing his reasons for any request or requirement pursuant to this clause.
52. The Agency shall maintain backup personnel and shall promptly provide replacement of every person removed, pursuant to this section, with an equally competent substitute from the pool of backup personnel.
53. In case of change in its team composition owing to attrition, the Agency shall ensure a reasonable amount of time-overlap in activities to ensure proper knowledge transfer and handover/ takeover of documents and other relevant materials between the outgoing and the new member. The exiting team member should be replaced with an equally competent substitute from the pool of backup personnel.
54. The following shall be considered as the approved team for the Agency:

As per Annexure

Contract administration

55. Either party may appoint any individual / organization as their authorized representative through a written notice to the other party. Each Representative shall have the authority to:
 - a) Exercise all of the powers and functions of his/her Party under this Contract other than the power to amend this Contract and ensure the proper administration and performance of the terms hereof; and Bind his or her Party in relation to any matter arising out of or in connection with this Contract.
 - b) The Agency along with the members of Sub-Implementation Agencies/third parties shall be bound by all undertakings and representations made by the authorized representative of the Agency and any covenants stipulated hereunder, with respect to this Contract, for and on their behalf.
 - c) For the purpose of execution or performance of the obligations under this Contract, the Client representative would act as an interface with the nominated representative of the Agency. The Agency shall comply with any instructions that are given by the Client representative during the course of this Contract in relation to the performance of its obligations under the terms of this Contract and the Tender.
56. A Committee comprising of representatives from the Client and the Agency shall meet on a regular basis as per schedule prescribed by Client to discuss any issues / bottlenecks being encountered. The minutes of these meetings shall be prepared and circulated to the participants.

Right of Monitoring, Inspection and Periodic Audit

57. The Client, reserves the right to inspect and monitor/assess the progress/performance/maintenance of the contract at any time during the course of the Contract, after providing due notice to the Agency. The Client may demand and upon such demand being made, the Client shall be provided with any document, data, material or any other information which it may require, to enable it to assess the progress of the project.
58. The Client shall also have the right to conduct, either itself or through another party as it may deem fit, an audit to monitor the performance by the Agency of its obligations/functions in accordance with the standards committed to or required by the Client and the Agency undertakes to cooperate with and provide to the Client / any other party appointed by the Client all documents and other details as may be required by them for this purpose. Any deviations or contravention identified as a result of such audit/assessment would need to be rectified by the Agency failing which the Client may, without prejudice to any other rights that it may have issue a notice of default.
59. Prior to any other party being appointed for such an audit, the Bidder will be requested to provide a list of entities that it deems not appropriate to conduct the said audit, which should be provided to Client within a 7 calendar days of such a request being made. Client shall then decide on this matter as appropriate.

Client Obligations

60. The Client Representative shall interface with the Agency, to provide the required information, clarifications, and to resolve any issues as may arise during the execution of the Contract. Client shall provide adequate cooperation in providing details, assisting with coordinating and obtaining of approvals from various governmental agencies, in cases, where the intervention of the Client is proper and necessary.
61. Client shall ensure that timely approval is provided to the Agency, where deemed necessary, which should include details and all specifications related to equipment/material required to be provided as part of the Scope of Work.

Information Security

62. The Agency shall not carry and/or transmit any material, information, layouts, diagrams, storage media or any other goods/material in physical or electronic form, which are proprietary to or owned by the Client out of its premises without prior written permission from the Client.
63. Agency acknowledges that Client business data and other Client proprietary information or materials, whether developed by Client or being used by Client pursuant to a license agreement with a third party (the foregoing collectively referred to herein as “proprietary information”) are confidential and proprietary to Client; and Agency agrees to use reasonable care to safeguard the proprietary information and to prevent the unauthorized use or disclosure thereof, which care shall not be less than that used by Agency to protect its own proprietary information. Agency recognizes that the goodwill of Client depends, among other things, upon Agency keeping such proprietary information confidential and that unauthorized disclosure of the same by Agency could damage Client and that by reason of Agency’s duties here under. Agency may come into possession of such proprietary information, even though Agency does not take any direct part in or furnish the services performed for the creation of said proprietary information and shall limit access thereto to employees with a need to such access to perform the services required by this agreement. Agency shall use such information only for the purpose of performing the said services.
64. Agency shall, upon termination of this agreement for any reason, or upon demand by Client whichever is earliest, return any and all information provided to Agency by Client including any copies or reproductions, both hard copy and electronic copy.

Ownership of Equipment

65. The Client shall own the equipment supplied by the Agency arising out of or in connection with this Contract. Client shall reserve rights to use the equipment or materials for any other applications or purpose other than mentioned in this RFP.

Insurance

66. Agency shall, at their own expense, arrange appropriate comprehensive insurance to cover all risks assumed by the Agency under this Contract in respect of its personnel deputed under this Contract as well as Agency’s equipment, tools and any other belongings of the Agency or their personnel during the entire period of their engagement in connection with this Contract. Client will have no liability on this account.
67. Agency shall take out insurance policies against all risks of loss or damage caused to Client property / equipment for property / equipment owned or hired by Client and the works and part of the works taken over by Client, including but not limited to theft, fire, flood, arson, and any other natural or man-made causes.
68. Notwithstanding anything contained in any provision of this Contract, save as specified above in this Clause Client shall defend, indemnify and hold Agency harmless from and against any losses,

damages, cost or claims relating to Client existing property except in case of gross negligence or wilful misconduct of the Agency, its sub-Agencies, their agents or employees, in which case the Agency shall be liable to bear any loss or damage occurring to the Property of the Client as a result of its gross negligence or wilful misconduct, provided however, that such liability shall be limited to 100% of the Contract Price.

69. "Gross Negligence" means: any act or failure to act (whether sole, joint or concurrent) by a person or entity which was intended to cause, or which was in reckless disregard of or wanton indifference to, avoidable and harmful consequences such person or entity knew, or should have known, would result from such act or failure to act. Notwithstanding the foregoing, Gross negligence shall not include any action taken in good faith for the safeguard of life or property, "wilful misconduct" means: "intentional disregard of good and prudent standards of performance or proper conduct under the Contract with knowledge that it is likely to result in any injury to any person or persons or loss or damage of property.
70. Certificate of Insurance: Before commencing performance of the Contract, Agency shall upon request furnish Client with certificates of insurance indicating (1) kinds and amounts of insurance as required herein (2) insurance Client or companies carrying the aforesaid coverage (3) effective and expiry dates of policies (4) that Client shall be given thirty (30) days written advance notice of any material change in the policy (5) waiver of subrogation endorsement has been attached to all policies and (6) the territorial limits of all policies. If any of the above policy expire or/ are cancelled during the term of this Contract and Agency fails for any reason to renew such policies, then Client may replace same and charge the cost thereof to Agency. Should the relapse in any insurance required to be carried out by Agency hereunder for any reason; losses resulting there from shall be to the sole account of the Agency. Such insurance shall be affected within Insurance Company incorporated and registered in India or jointly with a company of International repute and an Insurance Company incorporated and registered in India.

Indemnity

71. The Agency shall execute and furnish to the Client a Deed of Indemnity in favour of the Client in a form and manner acceptable to the Client indemnifying the Client from and against any costs, loss, damages, expense, claims, patents, trademarks, copyrights including those from third parties or liabilities of any kind howsoever suffered, arising or incurred inter alia during and after the Contract period out of:
- a) Any negligence or wrongful act or omission by the Agency or the Agency's Team or any sub-Agency/ third party in connection with or incidental to this Contract; or
 - b) Any breach of any of the terms of the Agency's Bid as agreed, the Tender and this Contract by the Agency, the Agency's Team or any sub-Agency/ third party.
72. The indemnity shall be to the extent of 100% in favour of the Client.

Confidentiality

73. The Agency shall not use Confidential Information, the name or the logo of the Client except for the purposes of providing the Service as specified under this Contract;
74. The Agency may only disclose Confidential Information in the following circumstances: with the prior written consent of the Client; to a member of the Agency's Team ("Authorized Person") if:
- c) the Authorized Person needs the Confidential Information for the performance of obligations under this Contract;
 - d) the Authorized Person is aware of the confidentiality of the Confidential Information and is obliged to use it only for the performance of obligations under this Contract
75. The Agency shall do everything reasonably possible to preserve the confidentiality of the Confidential Information including execution of a confidentiality agreement with the members of the, sub Implementation Agencies and other Agency's team members to the satisfaction of the Client.

76. The Agency shall sign a Non-Disclosure Agreement (NDA) with the Client. The Agency, its antecedents and the sub-Contractor shall be bound by the NDA. The Agency will be held responsible for any breach of the NDA by its antecedents, delegates or sub-Implementation Agencies
77. The Agency shall notify the Client promptly if it is aware of any disclosure of the Confidential Information otherwise than as permitted by this Contract or with the authority of the Client.
78. The Agency shall be liable to fully recompense the Client for any loss of revenue arising from breach of confidentiality. The Client reserves the right to adopt legal proceedings, civil or criminal, against the Agency in relation to a dispute arising out of breach of obligation by the Agency under this clause.

Term and Extension of the Contract

79. The term of this Contract shall be initially for a period of one years from the date of Go-Live issued by Client.
80. After the expiry of Contract period, Client may extend the Contract term at its discretion.

Prices

81. Prices quoted must be firm and shall not be subject to revision on any account whatsoever throughout the period of Contract.

Alteration / Variation

82. The Agency agrees that the requirements given in specifications of the Bidding Documents are broad requirements and are in no way exhaustive and guaranteed by the Client.
83. It shall be the responsibility of the Agency to meet all the requirements contained in the Bidding Documents and any upward revisions and / or additions of quantities / specifications / sizes given in Specifications and drawings etc. of the Bidding Documents required to be made during commissioning of Data Centre and department offices shall not constitute a change order and shall be carried out without a change order and shall be carried out without any time and cost effect to Client.
84. Further upward revisions and or additions required to make Agency's selected space, facilities, equipment and installation procedures to meet Bidding Documents requirements expressed and to make entire facilities safe, operable and as per specified codes and standards shall not constitute a change order and shall be carried out without any time and cost effect to Client.
85. Any upward revision and/or additions consequent to errors, omissions, ambiguities, discrepancies in the specification, etc. of the Bidding Documents which the Agency had not brought out to the Client notice in his tender shall not constitute a change order and such upward revisions and/or addition shall be carried out by Agency without any time and cost effect to Client.

Change Order

86. The change order will be initiated only in case
 - a) The Client directs in writing the Agency to include any addition to the scope of work covered under this Contract or delete any part of the scope of the work under the Contract,
 - b) SI requests to delete any part of the work which will not adversely affect the operational capabilities of the facilities and if the deletions proposed are agreed to by the Client and for which cost and time benefits shall be passed on to the Client
 - c) The Client directs in writing the Agency to incorporate changes or additions to the various requirements already covered in the Contract.
87. Any change order comprising an alteration which involves change in the cost of the works (which sort of alteration is hereinafter called a "Variation") shall be the Subject of an amendment to the Contract

by way of an increase or decrease in the Contract Price and adjustment of the implementation schedule if any.

88. If there is a different of opinion between the Agency and Client Representative whether a particular work or part of the work constitutes a change order or not, the matter shall be handled in accordance with the procedures set forth under “Procedures for Change Order”
89. Within 14 working days of receiving the comments from the Client or the drawings, specification, purchase requisitions and other documents submitted by the Agency for approval, the Agency shall respond in writing, which item(s) of the Comments is/are potential changes(s) in the “Scope of work” of the RFP covered in the Contract and shall advise a date by which change request (if applicable) will be submitted to the Client.

Procedures for Change Order

90. The representatives of both the parties will discuss on the new requirement for better understanding and to mutually decide whether such requirement constitutes a change order or not.
91. If it is mutually agreed that such Requirement constitutes a “Change Order” then a joint memorandum will be prepared and signed by the Agency and Client to confirm a “Change Order” and basic ideas of necessary agreed arrangement.
92. Upon completion of the joint memorandum referred to above the results along with all relevant details including the estimated time and cost effect thereof with supporting documents would be submitted to the Client to enable the Client to give a final decision whether Agency should proceed with the change order or not in the best interest of the works. The estimated cost and time impact indicated by Agency shall be considered as a ceiling limit and shall be provisionally considered for taking a decision to implement change order. The time impact applicable to the Contract shall be mutually agreed, subsequently, on the basis of the detailed calculations supported with all relevant back up documents. In case Agency fails to submit all necessary support and back up documents, the decision of the Client regarding time and cost shall be final and binding on the Agency.
93. If Client accepts the implementation of the change order above in writing, which would be considered as change order, then Agency shall commence to proceed with the relevant work stipulated in the change order pending final agreement between the parties with regard to adjustment of the Contract Price and the Construction Schedule.
94. In case, mutual agreement whether new requirement constitutes the change order or not, is not reached, then Agency in the interest of the works, shall take up the implementation of the work, if advised in writing to do so by Client Representative pending settlement between the two parties to the effect whether such requirement constitutes a change order or not as per the terms and conditions of Contract documents. The time and cost effects in such a case shall be mutually verified and recorded. Should it establish that the said work constitutes a change order; the same shall be compensated as per the clause given below.
95. The Agency shall submit necessary back up documents for the change order showing the break-up of the various elements constituting the change order for the Client review. If no agreement is reached between the Client and Agency within 60 days after Client instruction in writing to carry out the change concerning the increase or decrease in the Contract price and all other matters described above, either party may refer the dispute to arbitration.

Change of Size / Quantities

96. The Client will have the option to increase or decrease the size of the dedicated and exclusive space at its offices as well as the related quantities of equipment/material to be provisioned by the Agency as mentioned in the Contract.

Conditions for extra work / change order

97. The provisions of the Contract shall apply to extra work performed as if the Extra work / Change order has been included in the original Scope of work. However, the Contract Price shall increase / decrease and the Time Schedule shall be adjusted on account of the Extra work / Change orders as may be mutually agreed in terms of provisions set forth in this contract. The Agency's obligations with respect to such work remain in accordance with the Contract.
98. The rates provided by the Agency as part of its commercial quote will be considered as benchmark rates and may be revised to be benefit of the client.

Suspension of Work

99. The Agency shall, if ordered in writing by the Client Representative, temporarily suspend the works or any part thereof for such a period and such a time as ordered. The Agency shall not be entitled to claim compensation for any loss or damage sustained by him by reason of temporary suspension of the Works as aforesaid. An extension of time for completion, corresponding with the delay caused by any such suspension of the works as aforesaid shall be granted to the Agency, if request for same is made and that the suspension was not consequent to any default or failure on the part of the Agency. In case the suspension of works, is not consequent to any default or failure on the part of the Agency, and lasts for a period of more than 3 months, the Agency shall have the option to request the Client to terminate the Contract with mutual consent.
100. In the event that the Client suspends the progress of work for any reason not attributable to the Agency for a period in excess of 90 days in aggregate, rendering the Agency to extend his performance guarantee then Client shall bear only the cost of extension of such bank guarantee for such extended period restricted to the normal bank rates as applicable in the international banking procedures subject to the Agency producing the requisite evidence from the bank concerned.

Tenure of Contract

101. Unless terminated earlier, the Contract shall terminate on the completion of term as specified in the Contract and only after the obligations mentioned in the contract are fulfilled to the satisfaction of the Client.

Implementation Schedule

102. Implementation Schedule as per Annexure.

Payment Schedule

103. All payments under this Contract shall be made to / by the Lead Bidder only and will be made in Indian Rupees only.
104. Payment Schedule as per Annexure
105. Price Bid as per Annexure.
106. In case of non-conformity to SLA terms penalty will be deducted / recovered from the Agency.

Events of Default by the Agency

107. The failure on the part of the Agency to perform any of its obligations or comply with any of the terms of this Contract shall constitute an Event of Default on the part of the Agency. The events of default as mentioned above may include inter-alia the following:

- a) the Agency has failed to perform any instructions or directives issued by the Client which it deems proper and necessary to execute the scope of work under the Contract, or
 - b) The Agency has failed to adhere to any of the key performance indicators as laid down in the Key Performance Measures / Contract, or if the Agency has fallen short of matching such standards/targets as the Client may have designated with respect to any task necessary for the execution of the scope of work under this Contract. The above mentioned failure on the part of the Agency may be in terms of failure to adhere to timelines, specifications, requirements or any other criteria as defined by the Client;
 - c) the Agency has failed to remedy a failure to perform its obligations in accordance with the specifications issued by the despite being served with a default notice which laid down the specific deviance on the part of the Agency to comply with any stipulations or standards as laid down by the Client; or
 - d) the Agency/Agency's Team has failed to conform with any of the Service/Facility Specifications/standards as set out in the scope of work of this Tender document or has failed to adhere to any amended direction, modification or clarification as issued by the Client during the term of this Contract and which the Client deems proper and necessary for the execution of the scope of work under this Contract
 - e) the Agency has failed to demonstrate or sustain any representation or warranty made by it in this Contract, with respect to any of the terms of its Bid, the Tender and this Contract
 - f) There is a proceeding for bankruptcy, insolvency, winding up or there is an appointment of receiver, liquidator, assignee, or similar official against or in relation to the Agency.
 - g) The Agency/Agency's Team has failed to comply with or is in breach or contravention of any applicable laws.
108. Where there has been an occurrence of such defaults inter alia as stated above, the Client shall issue a notice of default to the Agency, setting out specific defaults / deviances / omissions and providing a notice of Sixty (60) days to enable such defaulting party to remedy the default committed.
109. Where despite the issuance of a default notice to the Agency by the Client the Agency fails to remedy the default to the satisfaction of the Agency, the Client may, where it deems fit, issue to the defaulting party another default notice or proceed to adopt such remedies as may be available to the Client.
110. If the Agency is given a penalty of more than 25% of any milestone payment, it constitutes a default and the Client has the right to consider the termination at any time after the default.

Consequences in Event of Default

111. Where an Event of Default subsists or remains uncured the Client may/shall be entitled to:
112. Impose any such obligations and conditions and issue any clarifications as may be necessary to inter alia ensure smooth continuation of Services and the project which the Agency shall be obliged to comply with which may include unilateral re-determination of the consideration payable to the Agency hereunder. The Agency shall in addition take all available steps to minimize loss resulting from such event of default.
113. The Client may, by a written notice of suspension to the Agency, suspend all payments to the Agency under the Contract, provided that such notice of suspension:
- a) shall specify the nature of the failure; and
 - b) shall request the Agency to remedy such failure within a specified period from the date of receipt of such notice of suspension by the Agency
114. Where the Client deems necessary, it shall have the right to require replacement of any of the Agency's agents / sub-Contractors / Agency with another suitable member. The Agency shall in such case terminate forthwith all their agreements/Contracts other arrangements with such member and find of the suitable replacement for such outgoing member with another member to the satisfaction of the Client who shall execute such Contracts with the Client as the Client may require. Failure on the part of the Agency to find a suitable replacement and/or terminate all agreements/Contracts with such member, shall amount to a breach of the terms hereof and the Client in addition to all other rights, have the right to claim damages and recover from the Agency all losses/ or other damages that may have resulted from such failure.

Termination of the Contract:

115. In case of termination of the Contract, Client retains the right to
- c) Retain such amounts from the payment due and payable by the Client to the Agency as may be required to offset any losses caused to the Client as a result of such event of default and the Agency shall compensate the Client for any such loss, damages or other costs, incurred by the Client in this regard. Nothing herein shall effect the continued obligation of the agents / sub-Contractor / other members of its Team to perform all their obligations and responsibilities under this Contract in an identical manner as were being performed before the occurrence of the default.
 - d) Invoke the Security Deposit and other Guarantees furnished hereunder, enforce the Deed of Indemnity, recover such other costs/losses and other amounts from the Agency may have resulted from such default and pursue such other rights and/or remedies that may be available to the Client under law.

Termination

116. The Client may, terminate this Contract in whole or in part by giving the Agency prior and written notice indicating its intention to terminate the Contract under the following circumstances
- a) Where the Client is of the opinion that there has been such Event of Default on the part of the Agency which would make it proper and necessary to terminate this Contract and may include failure on the part of the Agency to respect any of its commitments with regard to any part of its obligations under its Bid, the Tender or under this Contract.
 - b) Where it comes to the Client's attention that the Agency (or the Agency's Team) is in a position of actual conflict of interest with the interests of the Client in relation to any of terms of the Agency's Bid, the Tender or this Contract
 - c) Where the Agency's ability to survive as an independent corporate entity is threatened or is lost owing to any reason whatsoever, including inter-alia the filing of any bankruptcy proceedings against the Agency, any failure by the Agency to pay any of its dues to its creditors, the institution of any winding up proceedings against the Agency or the happening of any such events that are adverse to the commercial viability of the Agency. In the event of the happening of any events of the above nature, the Client shall reserve the right to take any steps as are necessary, to ensure the effective transition of the project to a successor Agency, and to ensure business continuity
 - d) Termination for Insolvency: The Client may at any time terminate the Contract by giving written notice to the Agency, without compensation to the Agency, if the Agency becomes bankrupt or otherwise insolvent, provided that such termination will not prejudice or affect any right of action or remedy which has accrued or will accrue thereafter to the Client.
 - e) Termination for Convenience: The Client may, by prior written notice sent to the Agency at least 1 month in advance, terminate the Contract, in whole or in part at any time for its convenience. The notice of termination shall specify that termination is for the Client convenience, the extent to which performance of work under the Contract is terminated, and the date upon which such termination becomes effective.
 - f) The Agency may, subject to approval by the Client terminate this Contract before the expiry of the term by giving the Client a prior and written notice at least 6 months in advance indicating its intention to terminate the Contract by paying losses to the Client as estimated by the Client.

Consequences of Termination

117. In the event of termination of this Contract due to any cause whatsoever except Termination for Convenience, Acts, Rules, Regulations, Procedures and Precedents shall be followed for further action on the SI, including up-to blacklisting of the SI. Before any adverse action is taken, the Agency will be provided reasonable opportunity to explain its position.
118. In the event of termination of this Contract due to any cause whatsoever, [whether consequent to the stipulated Term of the Contract or otherwise] the Client shall be entitled to impose any such obligations and conditions and issue any clarifications as may be necessary to ensure an efficient transition and effective business continuity of the project which the Agency shall be obliged to comply with and take

all available steps to minimize loss resulting from that termination/breach, and further allow and provide all such assistance to the Client and/or the successor Agency/Agency, as may be required, to take-over the obligations of the erstwhile Agency in relation to the execution/continued execution of the scope of this Contract.

119. Where the termination of the Contract is prior to its stipulated term on account of a Default on the part of the Agency or due to the fact that the survival of the Agency as an independent corporate entity is threatened/has ceased, or for any other reason, whatsoever, the Client through unilateral re-determination of the consideration payable to the Agency shall pay the Agency for that part of the Services which have been authorized by the Client and satisfactorily performed by the Agency up to the date of termination. Without prejudice any other rights, the Client may retain such amounts from the payment due and payable by the Client to the Agency as may be required to offset any losses caused to the Client as a result of any act/omissions of the Agency. In case of any loss or damage due to default on the part of the Agency in performing any of its obligations with regard to executing the scope of work under this Contract, the Agency shall compensate the Client for any such loss, damages or other costs, incurred by the Client. Additionally, the sub Agency / other members of its team shall perform all its obligations and responsibilities under this Contract in an identical manner as were being performed before the collapse of the Agency as described above in order to execute an effective transition and to maintain business continuity. All third parties shall continue to perform all/any functions as stipulated by the Client and as may be proper and necessary to execute the scope of work under the Contract in terms of the Agency's Bid, the Tender and this Contract.
120. Nothing herein shall restrict the right of the Client to invoke the Bank Guarantee and other Guarantees furnished hereunder, enforce the Deed of Indemnity and pursue such other rights and/or remedies that may be available to the Client under law.
121. The termination hereof shall not affect any accrued right or liability of either Party nor affect the operation of the provisions of this Contract that are expressly or by implication intended to come into or continue in force on or after such termination.

Penalty

122. The Agency should sign the Contract within the timelines as specified in this RFP. Any Delay in signing the Contract would attract a penalty of INR 50,000 per week.

Liquidated Damages for Non-Fulfilment of Commissioning Schedule

123. A penalty as per service level agreement of late completion beyond the stipulated commissioning schedule will be levied.
124. In the case it leads to termination, the Client shall give 30 days' notice to the Agency of its intention to terminate the Contract and shall so terminate the Contract unless during the 30 days' notice period, the Agency initiates remedial action acceptable to the Client.
125. The Client may without prejudice to its right to affect recovery by any other method, deduct the amount of liquidated damages from any money belonging to the Agency in its hands (which includes the Client right to claim such amount against Agency's Bank Guarantee) or which may become due to the Agency. Any such recovery or liquidated damages shall not in any way relieve the Agency from any of its obligations to complete the Works or from any other obligations and liabilities under the Contract.

Compliance with Statutory Requirements

126. The Agency shall have to comply with the Contract Labour Act (Regulation & Abolition Act), Apprentices Act 1961, Payment of Wages Act, Minimum Wages Act, Employee State insurance Act, Employee Provident Fund and Miscellaneous provision Act, Fatal Accident Act, and other applicable Labour and other Laws and Regulations in force from time to time.

Special Terms

127. Client reserves the right to reduce or increase the quantity requirement at the time of releasing the work order or by issue of an amendment subsequently.
128. Any additional active devices that will be provided by Client, during the Contract period, which may be under warranty/AMC shall be deployed and monitored by the Successful Bidder as per the SLA and terms and conditions of the tender.
129. The Agency is allowed to sub-Contract some of the activities mentioned in the Contract scope only after approval from the Client. The sub-Contracting should be limited to only one level. In case of any deviations, penalties may be imposed.
130. During the Contract period, any additional internet bandwidth as required in the name of Client is to be provided by the Agency at the rates finalised in the tender.
131. After the expiry of Contract period, it may be extended to maximum of two quarter at same quarterly cost in the Last Quarter, at the discretion of the Client. In case of any further extensions, the same may be done at a mutually agreed rate.

Applicability to other Clients

132. The Client, warrants that the terms and conditions of this agreement, including financial terms, may be used by any other legal body, within and without the city of Ujjain, to avail these services provided by the Agency without any liability to the client.

Dispute Resolution

133. The Client and the Agency shall make every effort to resolve amicably by direct informal negotiations, any disagreement or disputes, arising between them under or in connection with the Contract.
134. If, after Thirty (30) days from the commencement of such direct informal negotiations, the Client and the Agency have been unable to resolve amicably a Contract dispute, either party may require that the dispute be referred for resolution to the formal mechanism specified in Clauses.
135. In the case of a dispute or difference arising between the Client and the Agency relating to any matter arising out of or connected with this Contract, such dispute or difference shall be resolved in accordance under The Arbitration and Conciliation Act, 1996 (amended in 2015) and as amended from time to time.
136. The party raising the dispute shall bear the costs related to filing and proceedings of the Arbitration.
137. The Client may terminate this Contract, by giving a written notice of termination of minimum 30 days, to the Agency, if the Agency fails to comply with any decision reached consequent to this process.
138. Continuance of the Contract: Notwithstanding the fact that settlement of dispute(s) (if any) under any proceedings, the parties hereto shall continue to be governed by and perform the work in accordance with the provisions under the Scope of Work to ensure continuity of operations.

Limitation of the Agency's Liability towards the Client

139. Except in case of gross negligence or wilful misconduct on the part of the Agency or on the part of any person or company acting on behalf of the Agency in carrying out the Services, the Agency, with respect to damage caused by the Agency to Client property, shall not be liable:
 - a) for any indirect or consequential loss or damage; and
 - b) For any direct loss or damage that exceeds (A) the total payments payable under his Contract to the Agency hereunder, or (B) the proceeds the Agency may be entitled to receive from any insurance maintained by the Agency to cover such a liability, whichever of (A) or (B) is higher.

140. This limitation of liability shall not affect the Agency liability, if any, for damage to Third Parties caused by the Agency or any person or firm / company acting on behalf of the Agency in carrying out the Services.

Conflict of interest

141. The Agency shall disclose to the Client in writing, all actual and potential conflicts of interest that exist, arise or may arise (either for the Agency or the Agency's Team) in the course of performing the Services as soon as practical after it becomes aware of that conflict.

Severance

142. In the event any provision of this Contract is held to be invalid or unenforceable under the applicable law, the remaining provisions of this Contract shall remain in full force and effect.

Governing Language

143. The Agreement shall be written in English language. All correspondence and other documents pertaining to the Contract that are exchanged by parties shall be written in English language only.

"No Claim" Certificate

144. The Agency shall not be entitled to make any claim, whatsoever against the Client under or by virtue of or arising out of, this Contract, nor shall the Client entertain or consider any such claim, if made by the Agency after he shall have signed a "No claim" certificate in favour of the Client in such forms as shall be required by the Client after the works are finally accepted.

Publicity

145. The Agency shall not make or permit to be made a public announcement or media release about any aspect of this Contract unless the Client first gives the Agency its written consent.

Force Majeure

146. Force Majeure shall not include any events caused due to acts/omissions of such Party or result from a breach/contravention of any of the terms of the Contract, Bid and/or the Tender. It shall also not include any default on the part of a Party due to its negligence or failure to implement the stipulated/proposed precautions, as were required to be taken under the Contract.
147. The failure or occurrence of a delay in performance of any of the obligations of either party shall constitute a Force Majeure event only where such failure or delay could not have reasonably been foreseen, or where despite the presence of adequate and stipulated safeguards the failure to perform obligations has occurred. In such an event, the affected party shall inform the other party in writing within five days of the occurrence of such event. The Client will make the payments due for Services rendered till the occurrence of Force Majeure. However, any failure or lapse on the part of the Agency in performing any obligation as is necessary and proper, to negate the damage due to projected force majeure events or to mitigate the damage that may be caused due to the abovementioned events or the failure to provide adequate disaster management/recovery or any failure in setting up a contingency mechanism would not constitute force majeure, as set out above.

148. In case of a Force Majeure, all Parties will endeavour to agree on an alternate mode of performance in order to ensure the continuity of service and implementation of the obligations of a party under the Contract and to minimize any adverse consequences of Force Majeure.

Cooperation and Provision of Information

149. Except as otherwise provided elsewhere in this Agreement or the SLA, each Party (“Providing Party”) to this Agreement or to the SLA undertakes promptly to provide the other Party (“Receiving Party”) with all such information and co-operation which the Receiving Party reasonably requests, provided that such information and cooperation:
- a) does not require material expenditure by the Providing Party to provide the same;
 - b) is reasonably required by the Receiving Party in order for it to comply with its obligations under this Agreement or the SLA;
 - c) cannot be construed to be Confidential Information; and
 - d) is capable of being provided by the Providing Party.
150. Further, each Party agrees to co-operate with the contractors and subcontractors of the other Party as reasonably requested in order to accomplish the purposes of this Agreement.
151. During the exit management period Agency will allow Client access to information reasonably required to define the then current mode of operation associated with the provision of the services to enable the client to assess the existing services being delivered.

Confidential Information, Security and Data

152. The Agency will promptly on the commencement of the exit management period, supply to the Client or its nominated agencies the following:
- a) Information relating to the current services rendered and performance data relating to the performance of the services; Documentation relating to Project’s Intellectual Property Rights; any other data and confidential information related to Client;
 - b) Project data as is reasonably required for purposes of the Project or for transitioning of the services to its Replacing Agency in a readily available format.
153. All other information (including but not limited to documents, records and agreements) relating to the services reasonably necessary to enable the Client and its nominated agencies, or its Replacing Agency to carry out due diligence in order to transition the provision of the Services to Client or its nominated agencies, or its Replacing Agency (as the case may be).

Rights of Access to Information

154. At any time during the exit management period, the Agency will be obliged to provide an access of information to Client and / or any Replacing Agency in order to make an inventory of any material related to Client Project.

General

Relationship between the Parties

155. Nothing in this Contract constitutes any fiduciary relationship between the Client and Agency/Agency’s Team or any relationship of employer employee, principal and agent, or partnership, between the Client and Agency.
156. No Party has any authority to bind the other Party in any manner whatsoever except as agreed under the terms of this Contract.
157. The Client has no obligations to the Agency’s Team except as agreed under the terms of this Contract.

No Assignment

158. The Agency shall not transfer any interest, right, benefit or obligation under this Contract without the prior written consent of the Client.

Survival

159. The provisions of the clauses of this Contract in relation to documents, data, processes, property, Intellectual Property Rights, indemnity, publicity and confidentiality and ownership survive the expiry or termination of this Contract and in relation to confidentiality, the obligations continue to apply unless the Client notifies the Agency of its release from those obligations.

Entire Contract

160. The terms and conditions laid down in the Tender and all annexure thereto as also the Bid and any attachments/annexes thereto shall be read in consonance with and form an integral part of this Contract. This Contract supersedes any prior Contract, understanding or representation of the Parties on the subject matter.

Governing Law

161. This Contract shall be governed in accordance with the laws of India.

Jurisdiction of Courts

162. The Competent court in Ujjain have exclusive jurisdiction to determine any proceeding in relation to this Contract.

Compliance with Laws

163. The Agency shall comply with the laws in force in India in the course of performing this Contract.

Notices

164. A “notice” means:

- a) a notice; or
- b) a consent, approval or other communication required to be in writing under this Contract.

165. All notices, requests or consents provided for or permitted to be given under this Contract shall be in writing and shall be deemed effectively given when personally delivered or mailed by pre-paid certified / registered mail, return receipt requested, addressed as follows and shall be deemed received two days after mailing or on the date of delivery if personally delivered to Client, at:

Executive Director
Ujjain Smart City Limited
Mela Office, Kothi Road, Ujjain – 464010
ujjainsmartcity@gmail.com

To Agency at:

<Address>

<Phone :>

<Fax :>

166. Any Party may change the address to which notices are to be directed to it by notice to the other parties in the manner specified above. A notice served on a Representative is taken to be notice to that Representative's Party.

Waiver

167. Any waiver of any provision of this Contract is ineffective unless it is in writing and signed by the Party waiving its rights.

168. A waiver by either Party in respect of a breach of a provision of this Contract by the other Party is not a waiver in respect of any other breach of that or any other provision.

169. The failure of either Party to enforce at any time any of the provisions of this Contract shall not be interpreted as a waiver of such provision.

Modification

170. Any modification of this Contract shall be in writing and signed by an authorized representative of each Party.

Application

171. These General Conditions shall apply to the extent that provisions in other parts of the Contract do not supersede them.

IT Act 2000

172. Besides the terms and conditions stated in this document, the Contract shall also be governed by the overall acts and guidelines as mentioned in IT Act 2000, and Aadhaar Act as amended time to time by the Government of India and rules framed there under.

IN WITNESS WHEREOF BOTH THE PARTIES OF THIS AGREEMENT have hereunto set their hands and seal the day, month, and year first above written.

Signed, sealed and delivered for and on behalf of

M/s

NAME
DESIGNATION

In the presence of Witnesses:

1. Signature
Name:
Address

2. Signature
Name:

Address

Signed, sealed and delivered for and on behalf of
UJJAIN SMART CITY LIMITED

EXECUTIVE DIRECTOR

In the presence of Witnesses:

1. P.D.M.C.,
Ujjain

-
2. _____
Ujjain Smart City Limited
Ujjain

-
3. _____

-
4. _____
-

5 Bid Forms

5.1 Instructions to Bidders for Preparing the Bid Forms

The Bidders are requested to prepare their Bid documents in the formats as mentioned below. In preparing its bid, the Bidder must ensure all such information is provided and that the typographical aides are removed.

The Bidders are required to ensure that all documents provided are verifiable authentic documents. Any forging of documents may lead to immediate disqualification and other legal penalties. When requested by the Purchaser, the Bidders must supply originals of the documents so as to be verified against the submitted documents and should supply references so as to have the authenticity of the documents submitted verified.

The Bidders should also note that they should submit all documents to meet the requirements under this RFP. The Client would not accept any documents or amendments to documents, except as per the procedure specified in this RFP.

Bidders need not provide the Performance Security Bank Guarantee with their bids. Only the Bidder selected for award by the Client will be required to provide these securities.

All the pages (including documentary proofs and other documents that may be attached) should contain page numbers and would have to be uniquely serially numbered

The forms should be prepared in such a way so as to enable the evaluation committee to easily assess the bid documents.

5.2 Bid Checklist

Sl. No.	Check List Item	Requirement		To be filled in by the Bidder	
		Online	Hard Copy	Available with the bid	Page Number of the Bid
A	<i>General</i>				
1	Filled In Bid Checklist	✓	✓		
2	Document Fees	✓	Copy only		
3	EMD Copy	✓	Copy only (if B.G. has been requested and submitted then original)		
4	Signed Bid Document	-	✓		
B	<i>Eligibility / Eligibility Bid / Proposal</i>				
1	Cover Letter	✓	✓		

		Requirement		To be filled in by the Bidder	
Sl. No.	Check List Item	Online	Hard Copy	Available with the bid	Page Number of the Bid
3	Copy of Registration Certificate	✓	✓		
4	Copy of GST Registration	✓	✓		
6	Experience Credentials supporting the Eligibility	✓	✓		
<i>D</i>	<i>Financial Bid / Financial Proposal</i>				
	Financial Bid to be submitted online only.	✓	-	-	-

5.3 Bid / Proposal Forms

1. Bid Cover Letter

To

Executive Director
Ujjain Smart City Limited (USCL)
SimhasthaMela Office, Kothi Road,
Ujjain (M.P)

Date:

Subject: Proposal / Bid for <<INSERT NAME OF ASSIGNMENT>>

RFP Reference No: XX

Dear Sir or Madam,

With reference to your RFP Reference No. XX, Title “”, we hereby submit our Proposal for the same.

We have carefully read and understood the terms and conditions of the RFP and the conditions of the contract applicable to the RFP. We do hereby undertake to provision as per these terms and conditions.

We hereby acknowledge and unconditionally accept that the Authority can at its absolute discretion apply the criteria it deems appropriate, not just limiting to those criteria set out in the RFP and related documents, in short listing of bidder for providing services.

We understand that the Authority may cancel the bidding process at any time and that Authority is not bound to accept any bid that it may receive without incurring any liability towards the bidder.

We hereby declare that all information and details furnished by us in the Bid are true and correct, and all documents accompanying such application are true copies of their respective originals.

We agree to abide by our offer for a period of 180 days from the date of opening of prequalification bid prescribed by Authority and that we shall remain bound by a communication of acceptance within that time.

EMD and Tender Fee

We have submitted EMD of INR [] in the form of [.....] and Tender fee of INR [] online through e-Tendering Portal (www.mpeproc.gov.in),

We further confirm that our firm has no legal case pending in any court for winding up the company in India or elsewhere.

Declaration regarding Blacklisting

We hereby confirm that our firm has not been blacklisted any public sector body in India. We confirm that we do not have any terminated contracts during the past 5 years due to non-performance from the following:

- The Central, State and Local Government bodies in India,
- Any Smart City SPV,
- Any Public Sector Undertaking

We also confirm that the above applies to all parent and subsidiary organizations of the applicant firm.

Firm Prices

We affirm that the prices quoted are inclusive of design, development, delivery, installation, commissioning, training, providing facility management and handholding support, and inclusive of all out of pocket expenses, taxes, levies discounts etc.

Declaration regarding Technical Man-power

We declare that our organization has <INSERT NUMBER (IN WORDS)> Full-time professional (Technical/Engineering, Managerial, Other required professionals) staff engaged in Similar projects.

Complaints against Competition

We declare that in case we have any objections towards any other bidder participating in this tender, we shall communicate in detail the same, in writing, within seven calendar days from the date of opening of Technical Bids.

Relationship with Clients and Consultants

We declare that we do not have any existing business or other relations with the following entities and that we are not engaged in any activities that will otherwise affect the execution of the assignment:

1. Client: Ujjain Smart City Limited (Owned and Controlled by the Ujjain Municipal Corporation, the Government of Madhya Pradesh and Government of India).(CIN: U75100MP2016SGC041772)
2. Consultants: IPE Global Limited (CIN: U74140DL1998PLC097579)
3. Consultants: PricewaterhouseCoopers Pvt. Ltd. (CIN: U74140WB1983PTC036093) or any of the PwC network firms.

We also declare that should we become aware of any changes in our business relationships with the Consultants, the same shall be declared to you at the earliest possible opportunity, in writing.

Bid Acceptance

In the event of acceptance of our bid, we do hereby undertake:

- To supply the products and commence services as stipulated in the RFP document
- To undertake the project services for entire contract period from the date of signing of the contract as mentioned in the RFP document.

We do hereby undertake, that, until a formal contract is prepared and executed, this bid, together with your written acceptance thereof and notification of award of contract, shall constitute a binding contract between us.

We hereby declare that in case the contract is awarded to us, we shall submit the contract Bank Guarantee in the form prescribed within 15 days of issue of LOA.

No Deviations

We confirm that no technical deviations or any other conditions are attached here with our financial offer.

We fully understand and agree to comply that on verification, if any of the information provided in our bid is found to be misleading the selection process, we are liable to be dismissed from the selection process or termination of the contract during the project, if selected to do so, and further being barred / black-listed by the Authority for doing business with it.

We hereby declare that our bid is made in good faith, without collusion or fraud and the information contained in the bid is true and correct to the best of our knowledge and belief.

In case of any clarifications please contact _____ email _____, Mobile Number _____.

Thanking you,

Yours sincerely,

(Signature of the Lead bidder)

Printed Name

Designation

Seal

Date:

Place:

Business Address:

CERTIFICATE AS TO AUTHORISED SIGNATORIES

I _____, the [OFFICE HOLDER - Company Secretary / Managing Director] of _____, certify that _____ who signed the above Bid is authorized to do so and bind the company by authority of its board / governing body.

Date:

Signature:

(Company Seal)

(Name)

Alternately, a copy of the Board Resolution as to the Authorized signatory may be attached.

2. Copy of Certificate as to Legal Entity

Bidders are requested to attach a copy of the Registration Certificate under the laws of the country. In case the Bidder organization(s) have gone any Name change, a copy of the Name Change Certificate should also be attached.

3. Copy of GST Registration Certificate and PAN

Bidders are requested to attach a copy of the (provisional) GST Registration Certificate and the PAN.

4. Certificate as to Turnover

Bidders are requested to attach a copy of the certificate from the Chartered Accountant certifying the turnover of the Lead Member. The following format may be considered:

Sl. No.	Financial Year	Turnover	Remarks
1	2016-17		In case of provisional figures, please specify so.
2	2015-16		
3	2014-15		
4	2013-14		

Also certified that the net worth as on 31-March-2017 is Indian Rupees <<INSERT AMOUNT>>

5. Experience

The following documents should be submitted as part of the Experience

- A. A project information sheet.
- B. Copies of documentary evidence, including but not limited to agreements, contracts, work orders, client certificates, completion certificates (if applicable) CA or CS certificates, etc. The supporting documents submitted should clearly highlight the scope of the works to include the eligibility conditions.

Format of Project Information Sheet:

Name of Firm:	
Project Citation #:	
1.	Number of contract
	Name of contract
2.	Name of Purchaser
3.	Purchaser address
4.	Nature of Information Systems and special features relevant to the contract for which the Bidding Documents are issued
5.	Contract role (check one) <input type="checkbox"/> Prime Implementing Agency <input type="checkbox"/> Management Contractor <input type="checkbox"/> Subcontractor <input type="checkbox"/> Partner in a Joint Venture
6.	Amount of the total contract/subcontract/partner share (INR
8.	Date of award/completion
9.	Contract was completed _____ months ahead/behind original schedule (if behind, provide explanation).
10.	Contract was completed INR_____ under/over original contract amount (if over, provide explanation).
11.	Special contractual/technical requirements.
12.	Indicate the approximate percent of total contract value of Information System undertaken by subcontract, if any, and the nature of such Information System.

6. General Information Form

All individual firms and each partner of a Joint Venture that are bidding must complete the information in this form. Nationality information should be provided for all owners or Bidders that are partnerships or individually owned firms.

Where the Bidder proposes to use named Subcontractors for highly specialized components of the Information System, the following information should also be supplied for the Subcontractor(s), together with the other relevant information Forms

1.	Name of firm	
2.	Head office address	
3.	Contact Address	
4.	Telephone	Contact
5.	Fax	Telex
6.	Website	
7.	Place of incorporation / registration	Year of incorporation / registration
8.	Name, Designation, Address and Contact Details (Telephone, E-Mail Address, FAX) of the contact person to whom all references shall be made regarding this RFP:	

Contact Details of officials for future correspondence regarding the bid process:

Details	Authorized Signatory	Secondary Contact
Name		
Title		
Company Address		
Mobile		
Fax		
Email Id		

Qualification of the Firm (Certifications, etc.)		
Name		
1.		
2.		
5.		

7. Proposed Personnel, Candidate Summary and CV's

1.	Title of position
	Name of candidate
	Name of Firm (Bidder / Joint Venture Partner / Contracted Individually)
	Educational Qualification's
	Total Experience
	Relevant Experience
2.	Title of position
	Name of candidate
	Name of Firm (Bidder / Joint Venture Partner / Contracted Individually)
	Educational Qualification's
	Total Experience
	Relevant Experience
3.	Title of position
	Name of candidate
	Name of Firm (Bidder / Joint Venture Partner / Contracted Individually)

	Educational Qualification's
	Total Experience
	Relevant Experience

Candidate Summary

Detailed CV for each position as mentioned above should be provided. No CV should be more than 5 pages.

Position		
Candidate information	Name of candidate	Date of birth
	Professional qualifications, including Training and Certifications	
	Language Proficiency	
Present employment	Name of Employer	
	Address of Employer	
	Telephone	Contact (manager / personnel officer)
	Fax	Telex
	Job title of candidate	Years with present Employer
Past employment (Please repeat as required)	Name of Employer	
	Address of Employer	
	Telephone	Contact (manager / personnel officer)
	Fax	Telex

	Job title of candidate	Years with present Employer

Summarize professional experience over the last twenty years, in reverse chronological order. Indicate particular technical and managerial experience relevant to the project. Highlights of relevant assignments handled and significant accomplishments (Use following format for each project)

Name of assignment or project:	
Year:	
Location:	
Client:	
Main project features:	
Positions held:	
Activities performed:	

8. Technical Approach and Methodology

The Bidder shall provide adequate information to demonstrate clearly that it has the technical capability to meet the requirements for the assignment.

9. Un-priced Bill of Material

The Bidder is requested to provide the entire Bill of Material, without any price information in this table. A detailed unpriced Bill of Material is required to be provided.

The Bidders should note that even if some of the items are not mentioned in this unpriced Bill of Material, if required to perform the works as stated in the RFP, the same would be required to be provided.

Sl. No.	Equipment / Material / Software Description	Make / Model	Manufacturer	Quantity Proposed.

For each item in the Bill of Material, the Bidder is requested to enclose in the hard copy, any copies of relevant marketing literature / brochure / presentations, etc. that can help the committee to evaluate the item being proposed.

10. Specifications, Marketing Literature and other relevant Material regarding items mentioned in the Bill of Material

5.4 Financial Bid Forms

The bidders are invited to quote per kiosk per month amount of revenue share. The technically qualified bid giving the highest amount of revenue share will be awarded the project.

- All the Revenue rights will be with the Agency (this includes fee box, advertisement rights, VAS, Mobile Charging charges) except as defined in this RFP
- All the capital as well as O&M cost will be incurred by the Agency
- The concession period will be for 5 years.

The following Financial Bid Form is provided for guidance purposes only. The Bidders are requested to fill ONLY the form available ONLINE.

#	Item Description	Qty	Rate (Inclusive of All Taxes, Duties and Levies but Exclusive of GST)	Amount (Inclusive of All Taxes, duties and Levies by Exclusive of GST)
A	CAPEX ITEMS			
1	All New Kindle Oasis - 7" High Resolution Display, Waterproof, 32 GB, Wi-Fi + free 3G and Kindle Unlimited package for downloading books	4		
2	Apple iPad mini 4 128 GB Wi-Fi	1		
3	Apple iPad Pro 12.9 inch 64GB Wi-Fi	1		
3	Microsoft Surface Pro 4 (Core i5, 4GB, 128GB, 12.3")	2		
4	Android Tablet – 9", 32GB internal memory, 3GB RAM, Android Oreo, Full HD Resolution, Cameras at Front and Back, Wi-Fi	2		
5	Over Ear Headphone with built-in Microphone, High Bass Sound, (Sony, Logitech, Philips, Sennheiser or equally reputed brand) – Should have ability to connect to all of the above devices.	5		
6	Router with built-in firewall	1		
7	Internet Connection with 4 Mbps Bandwidth (Unlimited Download)	2		
8	Tablet Display Security Stand	10		
9	Executive Table as per specification – Teak Wood – Designer	1		
10	Executive Chairs as per specification – Mesh Revolving Chair with back support	10		
11	Air Conditioner – 1.5 Tonne Split AC (Make Blue Star, Hitachi, Carrier, Daikin or equivalent) – 5 Star Rating – with total 5 years Annual Maintenance Plan and Warranty. With Voltage Stabilizer	1		
12	Portable Fire Extinguisher for Electronic Devices	1		
13	Lacquered Glass White Notice Board 8 ft. X 4ft Toughened	1		
14	Soft Board 8 ft X 4 ft	1		

15	Book Shelf as per specification – Teak Wood	2		
16	Painting and Civil / Electrical work – Entire Room	Lump-sum		
18	UPS – 30 minutes power backup and Voltage Protection	As required		
19	Name Board – 6 sq. ft.	1		
20	Other Costs	As required		
B	OPEX ITEMS			
20	Support Specialist Cost	12 Months		
21	Other Costs	As required		
C	GRAND TOTAL			

6 Miscellaneous

6.1 Deed of Indemnity

<<To be executed by the Implementing Agency on a Non-Judicial Stamp Paper>>

Subject to Conditions mentioned below, the Implementing Agency(the "Indemnifying Party") undertakes to indemnify *Ujjain Smart City Limited and other associated entities* (the "Indemnified Party or Parties" as the case maybe) from and against all Losses on account of bodily injury, death or damage to tangible personal property arising in favour of any person, corporation or other entity attributable to Agency's negligence or wilful default in performance or non-performance under this Agreement. If Client promptly notifies Implementing Agency in writing of a third party claim against Client that any Service provided by the Implementing Agency infringes a copyright, trade secret or patents incorporated in India of any third party, Implementing Agency will defend such claim at its expense and will pay any costs or damages that may be finally awarded against Client. The Implementing Agency shall hold Client harmless towards any claim or damage or infringement from any third parties in relation in case of any breach of IPR / Patent rights etc.

Conditions

The indemnities set out in shall be subject to the following conditions:

- I. the Indemnified Party as promptly as practicable informs the Indemnifying Party in writing of the claim or proceedings and provides all relevant evidence, documentary or otherwise;
- II. the Indemnified Party shall, at the cost of the Indemnifying Party, give the Indemnifying Party all reasonable assistance in the Defence of such claim including reasonable access to all relevant information, documentation and personnel provided that the Indemnified Party may, at its sole cost and expense, reasonably participate, through its attorneys or otherwise, in such Defence;
- III. if the Indemnifying Party does not assume full control over the Defence of a claim as provided in this Article, the Indemnifying Party may participate in such Defence at its sole cost and expense, and the Indemnified Party will have the right to defend the claim in such manner as it may deem appropriate, and the cost and expense of the Indemnified Party will be included in Losses;
- IV. the Indemnified Party shall not prejudice, pay or accept any proceedings or claim, or compromise any proceedings or claim, without the written consent of the Indemnifying Party;
 - A. all settlements of claims subject to indemnification under this Clause will;
 - B. be entered into only with the consent of the Indemnified Party, which consent will not be unreasonably withheld and include an unconditional release to the Indemnified Party from the claimant or plaintiff for all liability in respect of such claim; and
- V. include any appropriate confidentiality agreement prohibiting disclosure of the terms of such settlement;
- VI. the Indemnified Party shall account to the Indemnifying Party for all awards, settlements, damages and costs (if any) finally awarded in favour of the Indemnified Party which are to be paid to it in connection with any such claim or proceedings;
- VII. the Indemnified Party shall take steps that the Indemnifying Party may reasonably require to mitigate or reduce its loss as a result of such a claim or proceedings;
- VIII. in the event that the Indemnifying Party is obligated to indemnify an Indemnified Party pursuant to this Article, the Indemnifying Party will, upon payment of such indemnity in full, be subrogated to all rights and defences of the Indemnified Party with respect to the claims to which such indemnification relates; and

If a Party makes a claim under the indemnity in respect of any particular Loss or Losses, then that Party shall not be entitled to make any further claim in respect of that Loss or Losses (including any claim for damages).

6.2 Non-Disclosure Agreement

This Non-Disclosure Agreement ("Agreement") is made and entered into ____ day of <<Month>>, 2017 by and between

Ujjain Smart City Limited having its office at Mela Karbala, Kothi Road, Ujjain 464010, Madhya Pradesh (hereinafter referred to as "USCL" which expression shall include its successors and permitted assignees) of the First Part.

and

[INSERT COMPLETE LEGAL NAME OF THE AGENCY] having its registered office at [INSERT THE REGISTERED ADDRESS OF THE Implementing Agency] (hereinafter referred to as "Implementing Agency" which expression shall include its successors and permitted assignees) of the Second Part.

USCL and Implementing Agency are hereinafter collectively referred to as "Parties" and individually as a "Party".

WHEREAS, through a competitive bidding process USCL has selected the Implementing Agency to implement [INSERT PROJECT NAME] for USCL and have entered into an Agreement dated..... (hereinafter the "Master Agreement") in this regard.

AND WHEREAS USCL may disclose to the Implementing Agency certain information which is confidential and proprietary in nature and wishes to protect such information from unauthorized disclosure and use;

NOW, THEREFORE, in consideration of the foregoing and the covenants and agreements contained herein and in the Master Agreement, Parties agree as follows:

1. Definitions

- a) The term "Confidential Information" shall include, without limitation, all information and materials, furnished by USCL to Implementing Agency, including information transmitted in writing, orally, visually, (e.g. video terminal display) or on magnetic or optical media, and including all proprietary information, customer & prospect lists, trade secrets, trade names or proposed trade names, logo, methods and procedures of operation, commercial or marketing plans, licensed document know-how, ideas, concepts, designs, drawings, flow charts, sales figures, diagrams, quality manuals, checklists, guidelines, processes, formulae, source code materials, specifications, programs, software packages, codes, bio-metric records and other intellectual property relating to the USCL's data, computer database, products and/or services. Confidential Information shall also include results of any tests, sample surveys, analytics, data mining exercises or usages etc. carried out by Implementing Agency in connection with the USCL's information or sensitive personal information as defined under any law for the time being in force.
- b) The term, "USCL" shall include the officers, employees, agents, consultants, contractors and representatives of USCL, including other government departments for which USCL may be rendering its services, and its successors and permitted assignees.

- c) The term, “Implementing Agency” shall include the directors, officers, employees, agents, consultants, contractors, sub-contractors, sub-implementation agencies and representatives of Implementing Agency, including its affiliates, subsidiary companies and permitted assigns and successors.

2. Protection of Confidential Information

With respect to any Confidential Information disclosed to Implementing Agency or to which Implementing Agency has access, Implementing Agency agrees that it shall:

- a) Use the Confidential Information only for accomplishment of the services to be performed under the Master Agreement and in accordance with the terms and conditions contained herein;
- b) maintain strict confidentiality of the Confidential Information and take all reasonable steps to enforce the confidentiality obligations imposed hereunder, but in no event shall take less care than it takes to protect the confidentiality of its own proprietary and confidential information and that of its clients;
- c) Not make or retain copy of any Confidential Information except as necessary, under prior written permission from USCL, in connection with the services to be performed under the Master Agreement, and ensure that any such copy is immediately returned to USCL even without express demand from USCL to do so;
- d) Not disclose or in any way assist or permit the disclosure of any Confidential Information to any person or entity without the express written consent of USCL except as provided in clause 6 below; and
- e) Return to USCL, or destroy, at USCL’s direction, any and all Confidential Information disclosed in a printed form or other permanent record, or in any other tangible form (including without limitation, all copies, notes, extracts, analyses, studies, summaries, records and reproductions thereof) immediately upon the earlier to occur of:
- (i) expiration or termination of the Master Agreement, or
 - (ii) on request of USCL.
- f) Not discuss with any member of public, media, press or any other person about the nature of arrangement entered between USCL and Implementing Agency or the nature of services to be provided by the Implementing Agency to USCL except with the written consent of USCL.

3. Exception

The aforesaid obligations of confidentiality shall not apply to the following information:

- (i) which has become generally available in the public domain without breach of this Agreement by the Implementing Agency; or
- (ii) which at the time of disclosure to Implementing Agency was known to Implementing Agency free of confidentiality restriction as evidenced by documentation in Implementing Agency’s possession; or
- (iii) which USCL agrees in writing is free of such confidentiality restrictions; or
- (iv) which has been received from a third party who owes no obligation of confidence in respect of such information; and
- (v) which is directed to be disclosed by a court of competent jurisdiction or by a governmental or regulatory authority provided that Implementing Agency have given prior prompt notice in writing to USCL of such disclosure;

4. Onus

Implementing Agency shall have the burden of proving that any disclosure or use inconsistent with the terms and conditions hereof falls within any of the exceptions provided in clause 3 above.

5. Remedies

Implementing Agency acknowledges and agrees that (a) any actual or threatened unauthorized disclosure or use of the Confidential Information by Implementing Agency would be a breach of this Agreement and may cause immediate and irreparable harm to USCL; (b) damages from such unauthorized disclosure or use may be impossible to measure accurately and injury sustained by USCL may be impossible to calculate and remedy fully. Implementing Agency acknowledges that in the event of such a breach, USCL shall be entitled to specific performance by Implementing Agency of Implementing Agency's obligations contained in this Agreement. Implementing Agency shall recompense USCL for any loss of revenue arising out of or in any way relate to, or result from breach of obligations under this Agreement by Implementing Agency. USCL reserves the right to adopt legal proceedings, civil or criminal, against the Implementing Agency in relation to a dispute arising out of breach of the confidentiality obligations of the Implementing Agency under this Agreement.

6. Need to Know

Implementing Agency shall restrict disclosure of Confidential Information to its employees and/or consultants and/or sub-consultants who have a need to know such information for accomplishment of services under the Master Agreement provided such employees and/or consultants and/or sub-consultants have agreed to abide by the terms and conditions of this Agreement and agree that they shall not disclose such Confidential Information to any affiliates, subsidiaries, associates and/or third party without prior written approval of USCL.

7. Intellectual Property Rights Protection

No license to Implementing Agency, under any trademark, patent, copyright, design right or any other intellectual property right is either granted or implied by the conveying of Confidential Information to Implementing Agency.

8. Authority

Parties represent and warrant that they have all necessary authority and power to enter into this Agreement and perform their obligations hereunder.

9. Governing Law

This Agreement shall be interpreted in accordance with and governed by the substantive and procedural laws of India and the parties hereby consent to submit to the exclusive jurisdiction of Courts and/or Forums situated at Ujjain, India only.

10. Amendments

No amendment, modification and/or discharge of this Agreement shall be valid or binding on the Parties unless made in writing and signed on behalf of each of the Parties by their respective duly authorized officers or representatives.

11. Severability

In the event any provision of this Agreement is held to be invalid or unenforceable under the applicable law, the remaining provisions of this Agreement shall remain in force and effect.

12. Waiver

If either party should waive any breach of any provision of this Agreement, it shall not thereby be deemed to have waived any preceding or succeeding breach of the same or any other provision hereof.

13. Survival

Implementing Agency agrees that all of its obligations undertaken herein with respect to Confidential Information received pursuant to this Agreement and obligations of indemnity shall survive for a period of 10 years after any expiration or termination of the Master Agreement.

14. Term

This Agreement shall come into force on the date first written above and, subject to aforesaid clause 13, shall remain valid up to expiry or termination of the Master Agreement.

IN WITNESS HEREOF, and intending to be legally bound, the Parties have executed this Agreement to make it effective from the date and year first written above.

For Ujjain Smart City Limited

For Implementing Agency

Name:

Name:

Title:

Title:

WITNESSES:

WITNESSES:

1.

1.

2.

2.

6.3 Format for Performance Bank Guarantee

<<TO BE EXECUTED UPON A BANK IN UJJAIN>>

FORM OF BANK GUARANTEE FOR PERFORMANCE SECURITY

BANK GUARANTEE NO. _____ **DATE:** _____

This deed of performance guarantee made this (date / month / year) by (Name and address of the Bank) (herein referred to as the Bank) which expression shall unless repugnant to the context and meaning thereof includes its legal representatives, successors and assignees and the **M/S. UJJAIN SMART CITY LIMITED** (hereinafter referred to as the **USCL**) which expression shall unless repugnant to the context and meaning thereof include its legal representative, successors and assignees.

Whereas, **USCL**, has awarded a Contract bearing No. _ _ _ _ _ **dated** _ _ _ on M/s. _____ (Name and address of the party) (Hereinafter referred to as the 'Implementing Agency') [INSERT PROJECT NAME]. And whereas, the Implementing Agency has agreed to submit a performance guarantee in the form of a Bank Guarantee to the **USCL**, in terms and conditions of Letter of intent/Notification of award No. dated, which will be kept valid up to **72 calendar months** from the date of Bank Guarantee. And whereas, the Bank and its duly constituted agent and officer has already read and understood the contract made between the **USCL**, and the Implementing Agency.

In consideration of the **USCL**., having agreed to award the contract, we _____ name of the Bank), do hereby guarantee, undertake, promise and agree to with the **USCL**, its legal representatives, successors and assignees that the within named (name of the Implementing Agency) their legal representatives and assignees will faithfully perform and fulfil everything within the Bidding Document and the Contract on their part to be performed or fulfilled, at the time (time being the essence of the contract) and in the manner therein provided, do all obligations there under and we further undertake and guarantee to make payment to the **USCL**, of Rs. _____ (Rupees only) being the 10% of the contract value, in case the Implementing Agency, their legal representatives and assignees do not faithfully perform and fulfil everything within the Letter of intent/Notification of award on their part to be performed or fulfilled, at the time and in the manner therein provided and do not wilfully and promptly do all obligations there under.

In case, the fails to perform or fulfil the Contract as per the terms and conditions agreed upon, the **USCL**, is entitled to demand an amount equal to 10% of the Contract value from the Implementing Agency and the demand made by the **USCL**, by itself will be conclusive evidence and proof that the Implementing Agency has failed to perform or fulfil his obligations and neither the Implementing Agency nor the Bank will be entitled to raise any dispute regarding the reasons for the failure of performance or fulfilment, on any ground.

We, (name of the Bank), do hereby undertake to an amount equal to 10% of the order value, being the amount due and payable under this guarantee without any demur, merely on a demand from the **USCL** , stating that the amount claimed is due by way of non – performance of the contractual obligations as aforesaid by the Implementing Agency or by reason of the Implementing Agency's failure to perform the said contractual commitments, any such demand made on the Bank shall be conclusive as regards the amount due and payable by the Bank under this guarantee. However, our

liability under this guarantee shall be restricted to an amount not exceeding Rs. _____ (Rupees only) being the amount equal to 10% of the total contract value.

We, (name of the Bank), further, agree that the performance guarantee herein contained shall remain in full force and effect for a period up to _____ from the date of Bank guarantee and till the **USCL**, certifies that the terms and conditions of the said contract have been fully and properly carried out by the said Implementing Agency and accordingly discharge the guarantee, unless a demand or claim under this guarantee is made on us in writing by the **USCL**, on or before _____, we shall be discharged from all liabilities under this performance guarantee thereafter.

We, (name of the Bank), further agreed with the **USCL**, that the **USCL**, shall have the fullest liberty without our consent and without affecting in any manner our obligations hereunder to vary any of the terms and conditions of the said Bidding Document and the Contract to extend the time of performance by the said Implementing Agency from time to time or postpone for any time and any of the power exercisable by the **USCL**, against the Implementing Agency and to forebear or enforce any of the terms and conditions relating to the said Bidding Document and the Contract and we shall not be relieved from our liability by reason of any such variation, or extension being granted to the said Implementing Agency, or for any forbearance, act or omission on the part of the **USCL**, to the said Implementing Agency by any such matter or thing whatsoever which under the law relating to sureties would but for this provision have effect of so relieving us.

This guarantee shall be in addition to and without prejudice to any other securities or remedies which the **USCL**, may have or hereafter possess in respect of the goods supplied/work executed or intended, to be supplied/executed and the **USCL**, shall be under no obligation to marshal in favour of the Bank any such securities or funds or asset that the **USCL**, may be entitled to be receiving or have a claim upon and the **USCL**, at its absolute discretion may vary, exchange, renew, modify or refuse to complete to enforce or assign any security or instrument.

The Bank agrees that the amount hereby guaranteed shall be due and payable to the **USCL**, on serving us with a notice, requiring the payment of the amount and such notice shall be deemed to have been served on the Bank either by actual delivery thereof to the Bank or by dispatch thereof to the Bank by Registered Post at the address of the Bank.

Any notice sent to the bank at its address by Registered Post acknowledged due as proof having delivered shall be deemed to have duly served on the Bank notwithstanding that the notice may not in fact have been delivered to the bank.

In order to give full effect to the provisions of this guarantee the Bank hereby waives all rights inconsistent with the above provisions and which the Bank might otherwise as a guarantor be entitled to claim and enforce.

We, _____, lastly undertake not to revoke this guarantee during its currency except with the previous consent of the **USCL**, in writing and the guarantee shall be a continuous and irrevocable guarantee up to a sum of Rs. _____ (Rupees only).

The Guarantee shall remain in force until _____ and a claim is performed against the bank within three months from the said date all rights of the Client under the guarantee shall cease and the Bank shall be released and discharged from all liabilities here under.

NOT WITH STANDING anything contained herein:

- i. Over liability under this guarantee shall not exceed Rs. _____
- ii. This bank guarantee shall be valid up to _____ and
- iii. We, (name of the Bank), are liable to pay the guarantee amount or any part thereof under this bank guarantee only and if **USCL**, serve upon us (name of the Bank), a written claim or demand on or before _____

(Signature with Seal)

Place:

Date:

Code No.

6.4 Format for Earnest Money Deposit Guarantee

<Bidders also have the choice to submit an original Fixed Deposit Receipt, in the name of Executive Director, Ujjain Smart City Limited in lieu of the EMD Bank Guarantee>

Date: dd/mm/yyyy

To,

Executive Director,
Ujjain Smart City Limited,
MelaKaryalaya, Kothi Road – Ujjain – 456010

Whereas M/s <<Name of Bidder>>, a company incorporated under the <<Act>>, its registered office at or (hereinafter called 'the Bidder') has submitted its Proposal dated ----- for “Selection of Agency for Integrated Traffic Management System (ITMS) in Ujjain City”

KNOW ALL MEN by these presents that WE <<Name of Bank>> of ----- having our registered office at ----- (hereinafter called "the Bank") are bound unto the Ujjain Smart City Limited (hereinafter called "the Client") in the sum of <<INSERT AMOUNT IN FIGURES AND IN WORDS>> for which payment well and truly to be made to the said Client, the Bank binds itself, its successors and assigns by these presents. Sealed with the Common Seal of the said Bank this ----- day of -----2017

THE CONDITIONS of this obligation are:

1. If the Bidder withdraws its bid during the period of bid validity specified by the Bidder in the Bid
2. If the Bidder, having been notified of the acceptance of its Proposal by the Client during the period of validity of Proposal, bidder:
 - a. withdraws his participation from the Proposal during the period of validity of Proposal document;
 - b. fails to extend the validity if required as requested or
 - c. fails to produce Performance Bank Guarantee in case of award of tender within 15 days of award of LOI or awarding contract whichever is earlier

We undertake to pay to the Client up to the above amount upon receipt of its first written demand, without the Client having to substantiate its demand, provided that in its demand the Client will note that the amount claimed by it is due to it owing to the occurrence of one or any or a combination of the above conditions, specifying the occurred condition or conditions.

This guarantee will remain in force up to the period of bid validity and its validity should be extensible to 90 days beyond the bid validity date. Any demand in respect thereof should reach the Bank not later than the above date.

(Authorized Signatory of the Bank)

END OF DOCUMENT

